

LEVEL II

①

A NEW AIRPORT FOR AUSTIN, TEXAS:
SITE SELECTION PROCESS AND
GENERAL NETWORK PLAN.

AD A105435

J. M. ...
by

⑩ Nov 77

④ 77

JAMES R. HUGHES B.A.

⑭ AFIT- CI-77-2477

Presented to the Faculty of the Graduate School of
The University of Texas at Austin
in Partial Fulfillment
of the Requirements
for the Degree of
MASTER OF ARCHITECTURE

DIS FILE COPY

DTIC
SELECT
OCT 1 1981

THE UNIVERSITY OF TEXAS AT AUSTIN

December 1979

"Original ...
pl ...
ion ...
white"

Approved for ...
Distribution ...

\$12000

D

1P

UNCLASS

SECURITY CLASSIFICATION OF THIS PAGE (When Data Entered)

REPORT DOCUMENTATION PAGE		READ INSTRUCTIONS BEFORE COMPLETING FORM
1. REPORT NUMBER 79-248T	2. GOVT ACCESSION NO. AD-A105	3. RECIPIENT'S CATALOG NUMBER 436
4. TITLE (and Subtitle) A New Airport for Austin, Texas: Site Selection Process and General Network Plan		5. TYPE OF REPORT & PERIOD COVERED THESIS/DISSERTATION
		6. PERFORMING ORG. REPORT NUMBER
7. AUTHOR(s) James R. Hughes		8. CONTRACT OR GRANT NUMBER(s)
9. PERFORMING ORGANIZATION NAME AND ADDRESS AFIT STUDENT AT: The University of Texas at Austin		10. PROGRAM ELEMENT, PROJECT, TASK AREA & WORK UNIT NUMBERS
11. CONTROLLING OFFICE NAME AND ADDRESS AFIT/NR WPAFB OH 45433		12. REPORT DATE Dec 79
		13. NUMBER OF PAGES 77
14. MONITORING AGENCY NAME & ADDRESS (if different from Controlling Office)		15. SECURITY CLASS. (of this report) UNCLASS
		15a. DECLASSIFICATION/DOWNGRADING SCHEDULE
16. DISTRIBUTION STATEMENT (of this Report) APPROVED FOR PUBLIC RELEASE; DISTRIBUTION UNLIMITED		
17. DISTRIBUTION STATEMENT (of the abstract entered in Block 20, if different from Report)		
18. SUPPLEMENTARY NOTES APPROVED FOR PUBLIC RELEASE: IAW AFR 190-17		29 SEP 1981 Fredric C. Lynch FREDRIC C. LYNCH, Major, USAF Director of Public Affairs
19. KEY WORDS (Continue on reverse side if necessary and identify by block number)		Air Force Institute of Technology (ATC) Wright-Patterson AFB, OH 45433 29 SEP 1981
20. ABSTRACT (Continue on reverse side if necessary and identify by block number) ATTACHED		

ABSTRACT

This thesis outlines the importance of a comprehensive approach to airport site selection process and proposes a general network plan for the new Austin airport. This study is not a technical one but attempts to explore and summarize criteria important to locating and evaluating optional airport sites.

Accession For.	
NTIS GRA&I	<input checked="" type="checkbox"/>
DTIC TAB	<input type="checkbox"/>
Unannounced	<input type="checkbox"/>
Justification	
By _____	
Distribution/	
Availability Codes	
Dist	Avail and/or Special
A	

DTIC
SERIALIZED
SEP 1 1981
D

81 10 6 203

A NEW AIRPORT FOR AUSTIN, TEXAS:
SITE SELECTION PROCESS AND GENERAL NETWORK PLAN

APPROVED:

Lawrence W. Spahr

James E. Tatum

Peter D. Seltman

81 10 203

FOOTNOTE

1. City of Austin, Texas: Request for Joint Use of Bergstrom Air Force Base, October 1976; prepared by R. Dixon Speas Associates, Aviation Consultants; p. 10.

TABLE OF CONTENTS

INTRODUCTION 1

CHAPTER

- I. Development and History of Airports..... 3
- II. Airport Categories and Classification..... 8
- III. Forecasting..... 15
- IV. Future Trends..... 17
 - Airport Development..... 17
 - The Airport in the Urban 'Zone'..... 18
- V. Site Selection..... 20
 - General Considerations..... 20
 - Austin Airport Site Selection..... 24
 - Overview..... 33
- VI. The New Austin Airport..... 37
 - General Characteristics..... 37
 - Background-Existing Airport Facilities..... 39
 - New Airport Configuration..... 46
 - Airport Network Plan..... 49
- VII. Airport Landuse Compatibility Planning In General..... 56
 - Purpose..... 56
 - Implementation Strategy..... 56
 - Planning Responsibilities..... 57
 - Citizen Participation..... 57
 - Financial Assistance..... 58
 - Land Use Guidance System..... 58
 - AICUZ Concept..... 62
 - Other Examples..... 63
 - Texas Airport System Plan..... 67

VIII. Summary - Alternatives Restated	74
· Airports as Systems	74
· Alternatives for Austin Airport	75
· Summary	77

INTRODUCTION

Airports have been referred to as a total 'City' devoted to dynamic movement. There are vast numbers of factors which influence their development and growth.

This thesis will outline the importance of a comprehensive approach to a site selection process and propose a general network plan for the new Austin airport.

A detailed site search is required to locate a new airport and must precede the development of a comprehensive master plan. This study will not be technical but will attempt to explore and summarize criteria important to locating and evaluating optional airport sites.

In order to define the problem and then propose a solution, specific phases are required to synthesize the desired system including: study of airport requirements, site selection, master planning, building design, financial planning, and operations planning.

The intent of this thesis is to focus on site selection, which becomes critical to establishing a framework for airport development and growth to support short-term as well as long-term aviation demands. Airport requirements, background facts and statistics are the basis for programming, design, and implementation of airport

facilities. The success of any large scale planning efforts will be based upon the comprehensiveness of this information and the coordination efforts of the planning and designing participants.

The relationship of the airport system to a regional comprehensive plan is also important. Since air traffic patterns and land transport access are critical to the airport and surrounding communities, the patterns for growth and development of city and airport must be interwoven. When an airport can no longer be extended, a new site must be sought in good time or alternative air traffic planning must ensue so that a region can continue its operations in the air transport network. Since the development of a new airport requires between 5 to 10 years to complete, its planning and accomplishment must be phased and controlled.

In the future, in order to successfully resolve all the difficulties involved with siting and developing airports we must attempt a reshaping of our urban structure and implement more suitable patterns of airports and airways. New approaches such as advance land leasing or purchase along with adequate controls over adjacent land areas will require effective planning at the local level.

CHAPTER I DEVELOPMENT AND HISTORY OF THE AIRPORT

Today our public considers air transportation as a right rather than a privilege. The ease with which we can move from one point to another in the air system at relatively low cost has increased our mobility immensely. We usually expect to go anywhere, anytime with little or no interference.

The rapid development of the aircraft industry has had a direct influence on our attitudes and values. Although the increased efficiency of the aviation operations has afforded us this pleasure at the same time it has strained the patterns of surrounding ground communities and airports. Even with our level of technology and management we have not kept pace in our programming and development of suitable air transportation centers.

Early airports were relatively simple to locate. The choice was merely a site with fairly level ground surface a short distance away from the city which was both inexpensive and accessible. There were no particular problems created such as noise and air pollution. The aircraft were much smaller and for the moment physical elements involved with planning and developing airports were accommodated.

However, today, detailed studies are required to determine the effects of specific terminal layouts and airport locations on adjacent communities and regions.

Before 1903 no powered aircraft had flown. The Wright Brothers' first flight took place on December 17, 1903, near Kitty Hawk, North Carolina. Jet planes were introduced to the commercial air operations in 1939. This development in aircraft technology had a phenomenal effect on increasing air travel. Air traffic in the U.S. has increased 20-fold within the last 20 years and is expected to continue this upward expansion.

Existing airports are not equipped to handle expected growth. Airports today are burdened with problems that affect both the airfield and surrounding communities. Current and future planning and design efforts along with improvements in aircraft technology must strive to eliminate air pollution, noise, and ground traffic congestion.

Population growth and economic trends as well as air traffic factors affect air transportation industry development. As these phenomena continue to grow the demands on airport capacities and efficiency are increased and require optimum concepts for airports.

Today air transportation centers are becoming a more integral part of the transportation facilities of regions. Their relation to the community must be

carefully thought out and planning actions integrated to accommodate growth. Some measure of control over adjacent land areas must be maintained in order to support current and future air traffic and land operations and development in urban centers.

Historically, the development patterns for airports has been similar. Our aircraft inventory was limited. Airplanes were smaller and fewer airplanes were required to satisfy the demand.

Air transportation gained popularity during the early 1920's. With the coming of air transportation the affects on commerce and social contact were expanding opportunities to a wider range of people. Approximately 113 primary airports were developed between 1930 and 1950. Early air travel services were basic and air carriers were competing for economic stability and the establishment of basic transportation operations.

After World War II cities grew quickly and eventually absorbed existing airports. As well as being a transportation node, the airport draws people and commercial development. Industry is also attracted to airport areas and industrial parks developed near airfields. People desire to live near work and accessible transportation facilities thus housing units were developed along with commercial and industrial facilities, all scattering

around the airport.¹ The continued pattern resulted in encroachment on adjacent areas which either limit or destroy future growth possibilities for airports as well as increasing danger in the event of accidents and escalating public complaints about airport activities.

Future years would see dynamic increases in air traffic requirements and services. Phenomenal growth spurred by continued aircraft improvements sets the pattern for airport development. The factor of constant change demands an airport system based upon a concept of flexibility.

FOOTNOTES

1. "Airport Development Planning", Progressive Architecture, November 1961, pp. 158.

CHAPTER II AIRPORT CATEGORIES AND CLASSIFICATION

Generally airports are classified by the types of aircraft they can accommodate or by the service they can provide to the public. Three broad divisions are listed as follows:

- A. Air Carrier Airports; service scheduled airliners though they can also serve civil aviation.
- B. General Aviation Airports; serve segments of civil aviation other than scheduled airlines (i.e. business flying, instruction, rentals, or industrial).
- C. Military Airports.

The role for an Air Carrier Airport is determined by the routes and markets it serves non-stop. The classification descriptions used by the FAA for air carrier service are as follows:

LOCAL: Airports to serve on local service routes to providing service in the "short-haul" category normally not exceeding 500 miles.

TRUNK: Airports to serve on airline trunk routes and engage in intermediate length hauls normally not to exceed 1,000 miles.

CONTINENTAL: Airports serving long non-stop flights exclusive of coast to coast, normally entirely within the confines of the Continental U.S. These airports serve non-stop flights up to 2,000 miles.

INTERCONTINENTAL: Airports to serve the longest range non-stop flights in the transcontinental, transoceanic and intercontinental categories.¹

The airport role for a general aviation airport is determined by the types of general aviation aircraft using the airport and their frequency.

Usually the physical size of an airport is determined by the length of its runway(s). Runways will vary according to the type of aircraft to be accommodated. Specific requirements vary with each airport location. However the FAA does outline design fundamentals that must be considered to ensure compliance with safety and functional use factors associated with the development of any airport.

The airport system includes three primary elements: the landing area (runways and taxiways); the terminal area (apron, buildings, car parking areas, hangars, etc.); and the terminal air traffic control (the procedures and techniques governing the control of air traffic in the airspace surrounding the airport).

The airport configuration is dependent upon the runway layout which is determined by a number of criteria including wind, noise, land area, and topography.

The overall capacity of the airport system can be affected by any one of the three primary airport

elements. An airport's capacity is defined as the number of aircraft movements an airport can process within a specified period of time. A "movement" is defined as a landing or take-off.

The efficient airport system would be one where all three elements are in balance, resulting in the desired number of aircraft that can arrive and leave within a specified period of time. Thus aircraft can land, taxi, park, unload, process passengers and depart with the least amount of inconvenience. Various runway configurations can accommodate different capacities. Basic runway configurations include the following: Ref. Fig. II-I, A through F.

- A. Single runway. Estimated capacity; can support between 45 and 60 operations per hour under VFR (Visual Flight Regulations) and 20 to 40 operations per hour under IFR (Instrument Flight Regulations).
- B. Parallel runways. Effective capacities based upon separation width of runways. Estimated operations are between 75 to 95 under VFR and 40 to 45 under IFR. Runway separation would be 700 feet. Runways may be staggered.
- C. Divergent runways. May be referred to as "intersecting" or non-intersecting runways. This type of configuration is estimated to have high capacities (100 plus). Local winds must be relatively light to allow high capacity operations.
- D. Tridirectional runways. Variation of the divergent configuration.
- E. Multidirectional runways. Also a variation of divergent configuration.

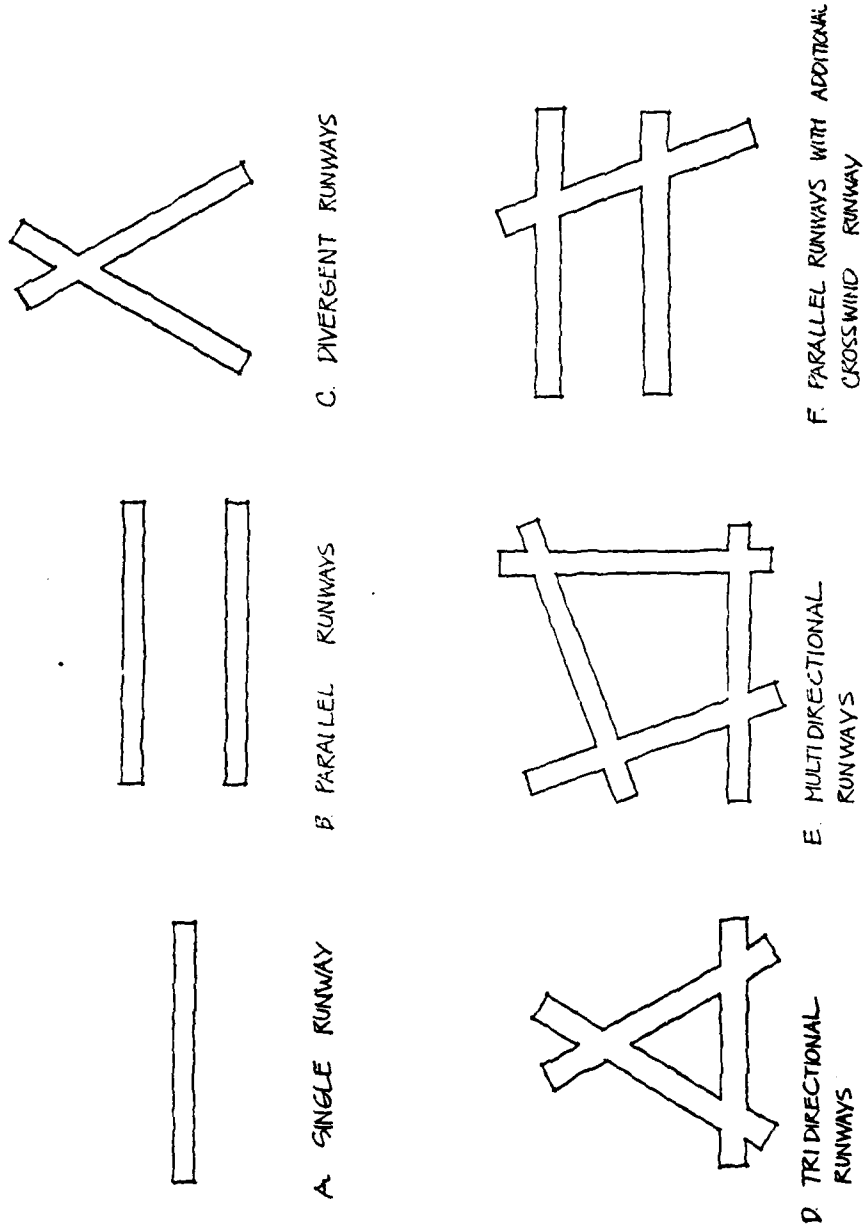

Figure II-1 Basic Runway Configurations
Source: Horonjeff, p. 166

F. Parallel runways with additional "intersecting" runway².

Selection of runway configuration is based upon local conditions and the overall capacity of traffic the airport system is programmed to handle.

The characteristics and volume of aircraft is probably the most important factor in assessing airport capacity. A parallel runway configuration with an additional cross-wind runway has, in the appropriate situation, the advantages of providing a high acceptance rate of operational capacity and requires less overall land area than other configurations.

The most desirable airport layout would be one that provides for both the shortest taxiing distance from the terminal area to the runways and the least interference and delay in landing, taxiing, and take-off operations.

The sketches in Fig. II-2 illustrate general principles governing airport configuration but are not representative of optimum layouts.³ Specific configurations must be developed along with other concerns in a master planning process.

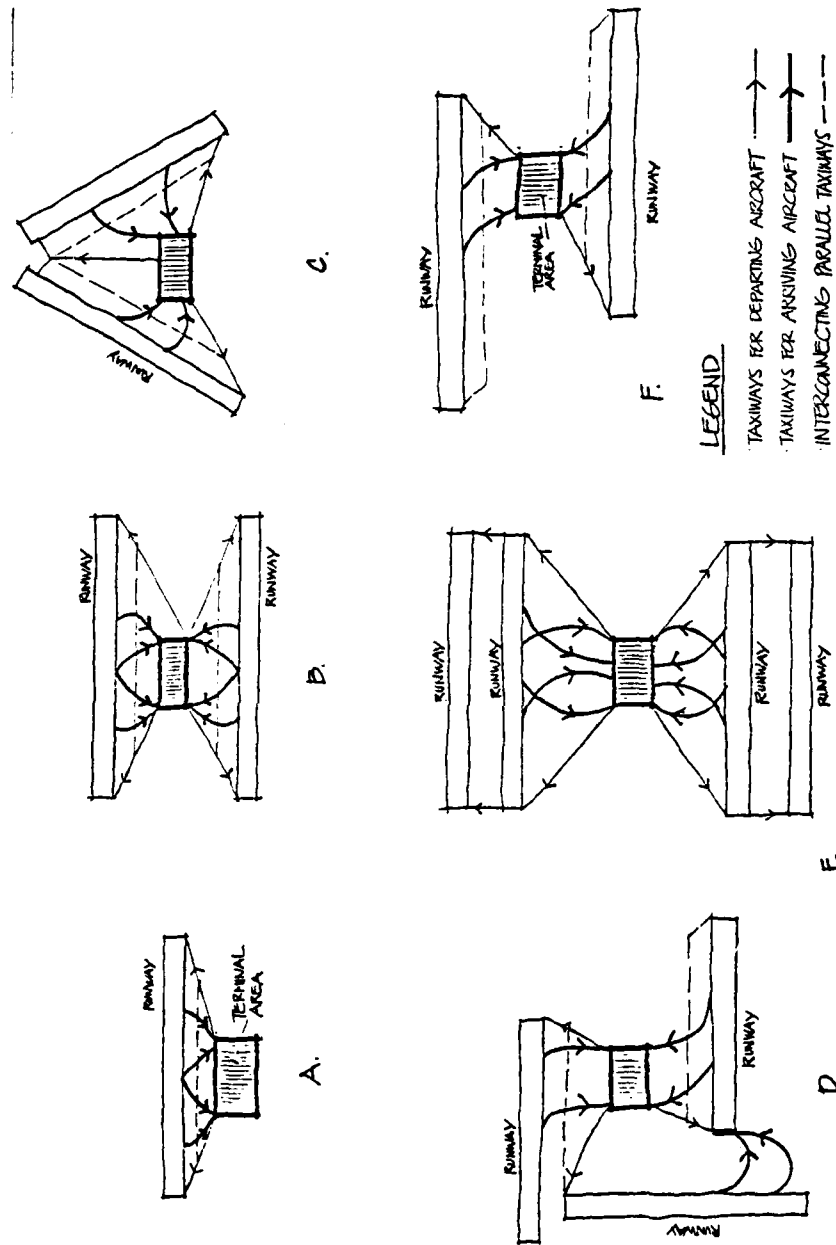

Figure II-2 Typical Airport Configurations
 Source: Horonjeff, p. 172

FOOTNOTES

1. Goodman, William I., and Freund, Eric C., Principles and Practice of Urban Planning, International City Manager's Association, Washington, D.C., 1968, pp. 178.
2. Horonjeff, Robert, The Planning and Design of Airports, McGraw-Hill Book Company, Inc., 1962, pp. 166.
3. Ibid, pp. 172.

CHAPTER III FORECASTING

A critical factor in developing a master plan for an airport is an estimate of future volumes of traffic. This data must be translated into physical building requirements.

Usually one of two possible methods of forecasting is used. One method is called trend forecasting where future requirements are based upon traffic volume observed over a given period of time. A second method is called model forecasting where requirements are based upon the projected traffic volume and the data for the socio-economic structure of a region.

Specific facts needed in estimating volumes of airline traffic would include:

1. Area served by the airport.
2. Origin and destination of residents and non-residents of the area.
3. Population growth of the area to be served.
4. Economic character of the area.

The principal categories for which estimates are usually prepared would include:

1. Passengers
2. Cargo
3. Mail
4. The number of aircraft required to serve these categories.

Specific area requirements are based upon estimates of future aviation criteria and activity. These estimates are normally projected for a 20 year time frame. In designing the terminal building the standard for determining area requirements is the number of peak-hour passengers. A significant design factor would be the projected number of passengers the terminal building would handle at its busiest hour of the busiest day.

A knowledge of projected capacities of aircraft used at the specific airport is required to determine the number of aircraft parking spaces related to the projected peak-hour passengers thus providing a basis to formulate and evaluate appropriate airport runway and terminal configurations.

In the case of air cargo a similar comparison is required for determining necessary facilities to serve this processing requirement.

The study of forecasting is a detailed process in itself and requires the services of special consultants who coordinate in the overall airport planning process. New and modified processes using computer technology are being studied and formulated and will require refinement in order to provide accurate demand forecasts for future airport planning and development.

CHAPTER IV FUTURE TRENDS

Airport Development

"Airport design is the result of compromise between functional, technical, and economic requirements, revealed by study of traffic, geographical and sociological conditions, local regulations and traditions and budget limitations".¹ The future poses a number of questions for future growth and development. What type of facilities will provide efficient operations to support increases and changes in air traffic activities? The prime concern will be new approaches for programming, planning, and designing to deal with population centers in accommodating the supersonic and advanced technology jets of current inventory and new sophisticated aircraft. Future success in handling aviation requirements will demand renewed coordination between the airline industry, airport operators, designers and local government. In the future, planners will use simulation techniques to test various concepts in all areas of airport development; this could allow corrective measures and modifications of concepts to be performed before actual application in airport development. Additionally airport development will require support at a regional planning level.

This support would take the form of planning guidance and effective review and approval of local planning efforts. The public must also become familiar with and understand that airports should be considered as living entities which significantly impact their communities. The new airport must be studied in relation to its surroundings and the role it plays in this setting. The linkage and character of the new airport develops with the fabric of the community.

The Airport in the Urban 'Zone'

"The survival of the airport depends upon its capacity to adapt to its environment and to evolve whilst resisting to external pressures, without losing its true nature".² The airport can and should be included in the "Urban Zone" in order to fulfill its appropriate role in the community. However, economic and social advantages must be compared to the more quantifiable limits of environmental impact. Air pollution, noise abatement, and land transport issues must be recognized and dealt with.

It is clearly infeasible to project a comprehensive plan for urban development without considering the role of the airport. The overall economic and social impacts cannot be overlooked but can be reinforced and resulting beneficial aspects become a vital part of the investment of the community.

FOOTNOTES

1. "Airports", L'Architecture d'Aujourd' Hui, V. 43
Juillet 1971, No. 156, Article # 2.
2. Ibid, Article # 4.

CHAPTER V SITE SELECTION

General Considerations

Since the development of a new airport has a significant impact on a community and future growth, a comprehensive study is required to propose a suitable site and reveal its overall physical, social and economic impacts. The proposed site and eventual master plan must be based upon a long-range fulfillment of air transportation requirements and its relationship to a regional transportation network.

Generally an airport will be influenced by the following factors:

1. Type of surrounding development.
2. Atmospheric patterns and environmental conditions.
3. Accessibility to ground transportation.
4. Availability of land for expansion.
5. Presence of other airports.
6. Surrounding obstructions.
7. Economy of construction.
8. Availability of utilities.
9. Proximity to aeronautical demand¹.

BRIEF DESCRIPTION OF GENERAL CONSIDERATION

1. Type of Surrounding Development

Proximity to residential areas and schools should be avoided. Sites which will provide current and future compatible use with other commercial or industrial uses should be sought.

2. Atmospheric Patterns and Environmental Conditions

Significant changes in local atmospheric conditions such as the presence of fog, haze, and smoke can cause a reduction in visibility which would effectively lower air traffic operations or capacity. A thorough analysis of weather data is important. Specific analysis of noise, air quality, water quality, and ecological impacts is required during the environmental impact study.

3. Accessibility to Ground Transportation

Accessibility to ground transport should be studied and transit time from passenger's point of origin to the airport estimated. A number of surveys for ground transport to the airport in the United States indicate that the majority of passengers, visitors, and airport employees travel by private automobile.¹ This trend is expected to continue in the future, thus as a general impact upon airports in this country the private automobile will continue to be an important

means of transportation to the terminal. The planning of streets and highways to an airport and its parking areas are important factors to be dealt with.

4. Availability of Land for Expansion

Current planning criteria for airports include the availability of land not only for airport installations but also for clear zones and noise impacted areas within specified noise contour lines. Because aviation growth is so dynamic it is also necessary to consider acquiring additional land to support future expansion of airfield and terminal facilities. Expansion sites must be virtually flat with no topographic obstructions.

5. Presence of Other Airports

Consideration must be given to existing or planned airports in the general area during a site selection process. Airports must be located an appropriate (8 to 15 miles) distance from each other to prevent any interference in air traffic patterns. This action must be coordinated with the federal aviation administration.

6. Surrounding Obstructions

Another important consideration for location is that approaches necessary for the development of runways

are free of obstructions. The provision of this free approach zone will require height restrictions near the airport in line with the runways. Since the purchase of land necessary to protect approaches is not economically feasible, zoning for height restrictions should be initiated as soon as a site has been selected. Natural features such as hills, valleys, etc. must also be taken into account while runway layout and air traffic patterns are developed.

7. Economy of Construction

Optional sites will provide a range of costs to be evaluated during site selection.

8. Availability of Utilities

A new airport will require large quantities of water, natural gas or oil, electric power, and fuel for aircraft and support vehicles. The importance of utilities will be reflected in an overall construction cost estimate. Most of the utilities will have to be transported by truck, rail, or pipeline. Also large quantities of sewage must be disposed of through existing local mains or the airport may have to construct a separate disposal plant.

9. Proximity to Aeronautical Demand

In an overall selection process for a new airport site it is important to provide a location which will result in the shortest ground access time possible. Locating an airport a considerable distance from the center of population has a negative impact on overall traffic efficiency.

Austin Airport Site Selection

The following factors were specifically reviewed to develop a general suitability 'zone' for the future Austin airport:

1. Airspace
2. Topography
3. Accessibility
4. Landuse
5. Expansion
6. Soils
7. Human Settlement

The manual review of the above factors in this thesis is not meant to replace a comprehensive site search process but to attempt to suggest three possible sites which could then be aligned in order of suitability by evaluating a wider range of influencing factors. Other methods for evaluation of site factors using a computer

can be employed to analyze and order suitability. One such method is the CASAT program which utilizes weighted parameters and is a numerically valued adaptation of the McHarg technique of environmental factor maps overlaid to determine suitability developed at the School of Architecture, California State Polytechnic College, San Luis Obispo.² The more detailed the data and selection of parameters is, the more accurate and objective the site search. The designer's judgement still plays a role in the overall site selection process whether the approach is traditional (careful detailed scanning of maps) or an application of a computer in the weighting of parameters.

Selection Outline:

The following outline will present a description of the general suitability 'zone' for the new Austin airport as well as three suggested sites within the suitability 'zone'. The suitability 'zone' was developed by overlaying the factors depicted in base maps A-Bergstrom North - South approach; B-Topography-slope percentage; and C-Accessibility boundary; reference Figures V-1, V-2, and V-3 respectively. The combination of the above three base maps is represented in Figure V-4, the general 'suitability zone'. This 'zone' is considered to be the most desirable

area for airport development as influenced by the above factors.

The location of three possible sites depicted in Figure V-4 were selected primarily for their immediate proximity to major highway routes and center of demand in the Austin urban area. Beyond this the three sites were found to provide acceptable topography, limited impact on existing residential fabric, adequate land for expansion, and proximity to existing urban infrastructure.

Review of Influencing Factors

1. Airspace

Generally the airspace operations must be coordinated with Bergstrom Air Force Base since its impact on location of the new airport will be a primary consideration. In Figure V-1 the north-south approach path for instrument aircraft extend approximately ten miles north and south. This factor establishes a constraint on an airport located west of the approach 'corridor'. Any east bound commercial aircraft must cross the north-south approach. A major portion of the flights departing Austin are bound for the eastern and north-eastern part of Texas. An airport location east of this north-south approach 'corridor' would be more desirable.

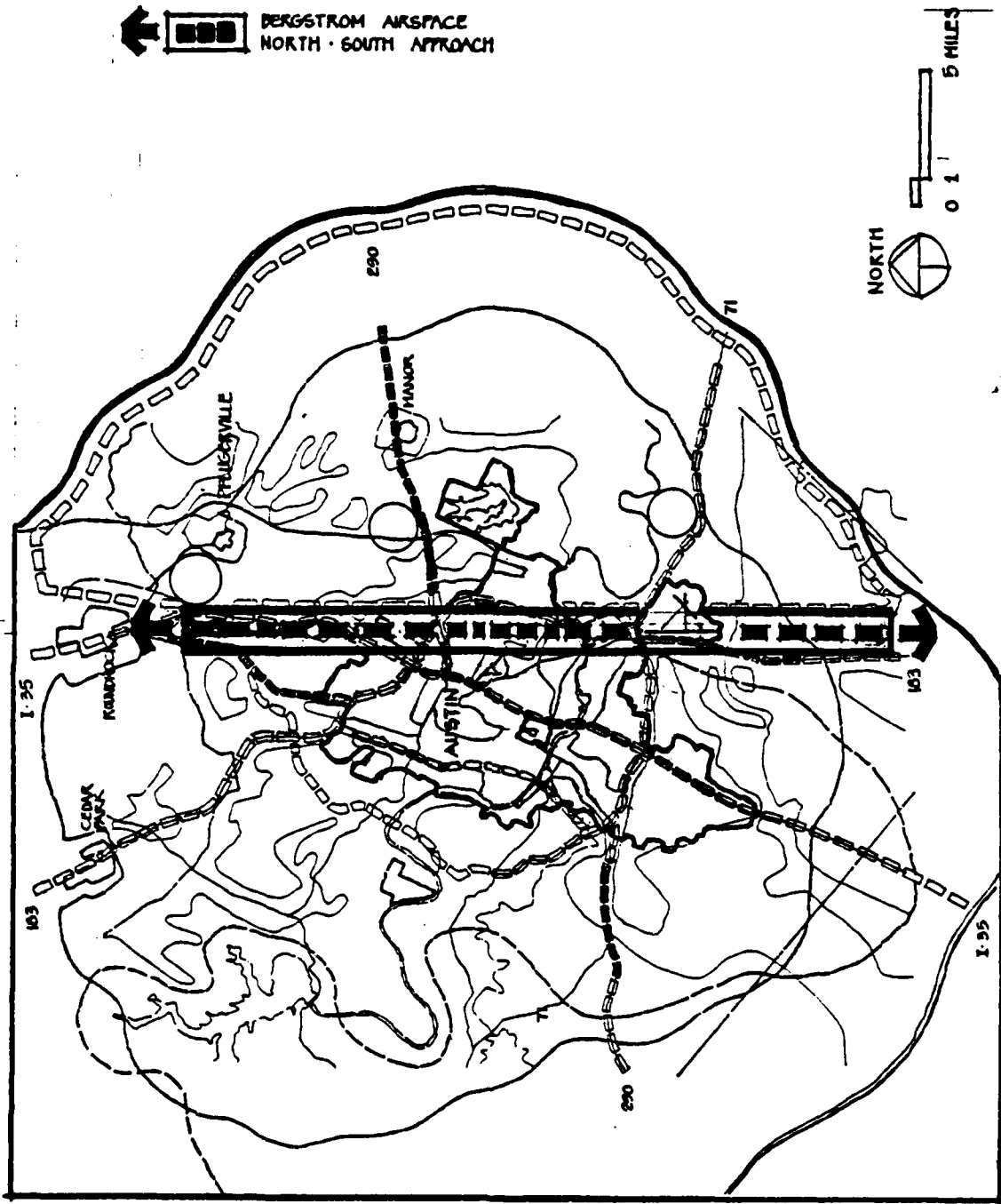

Figure V-1 Base Map A

SLOPE PERCENTAGE

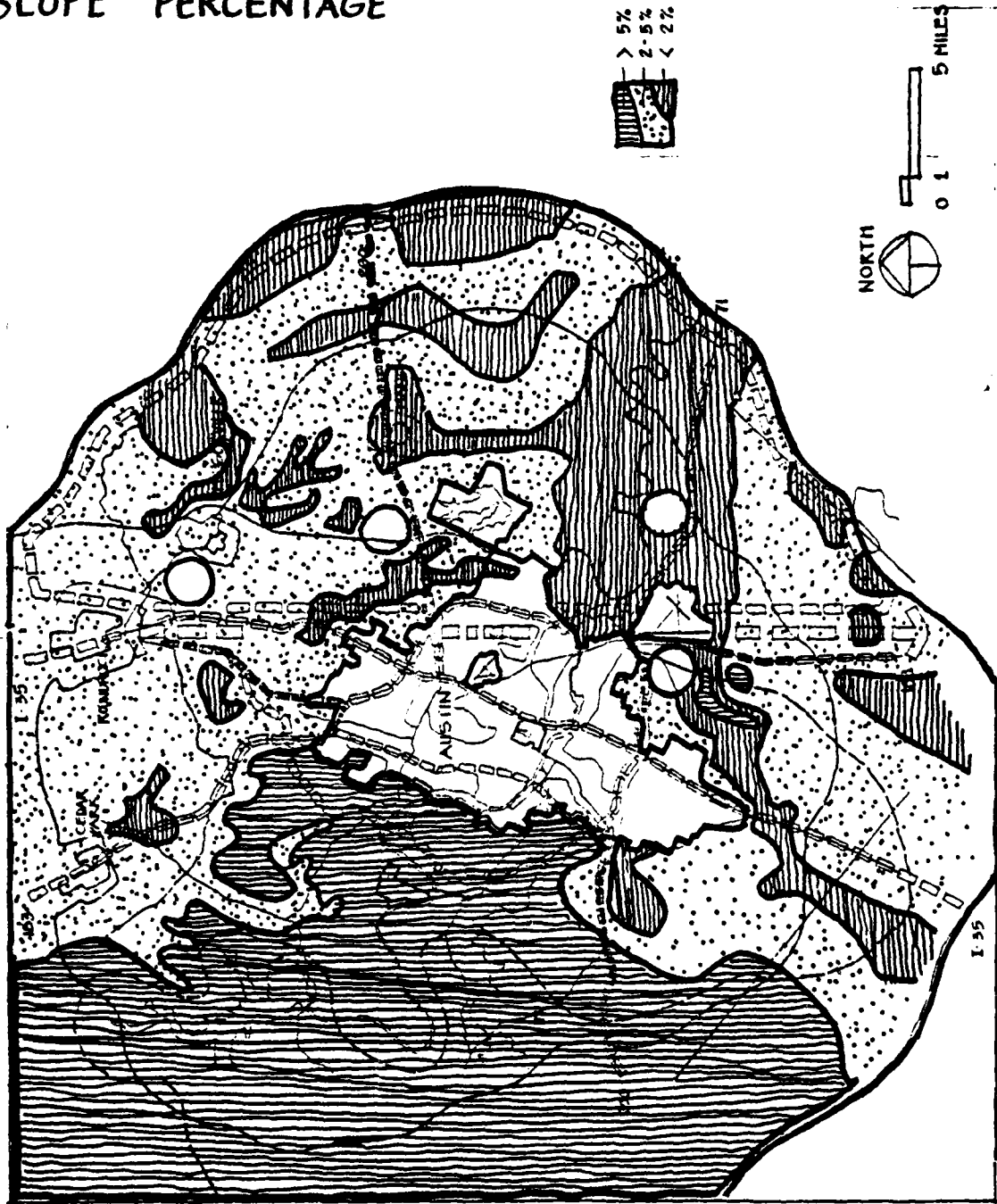

Figure V-2 Base Map B

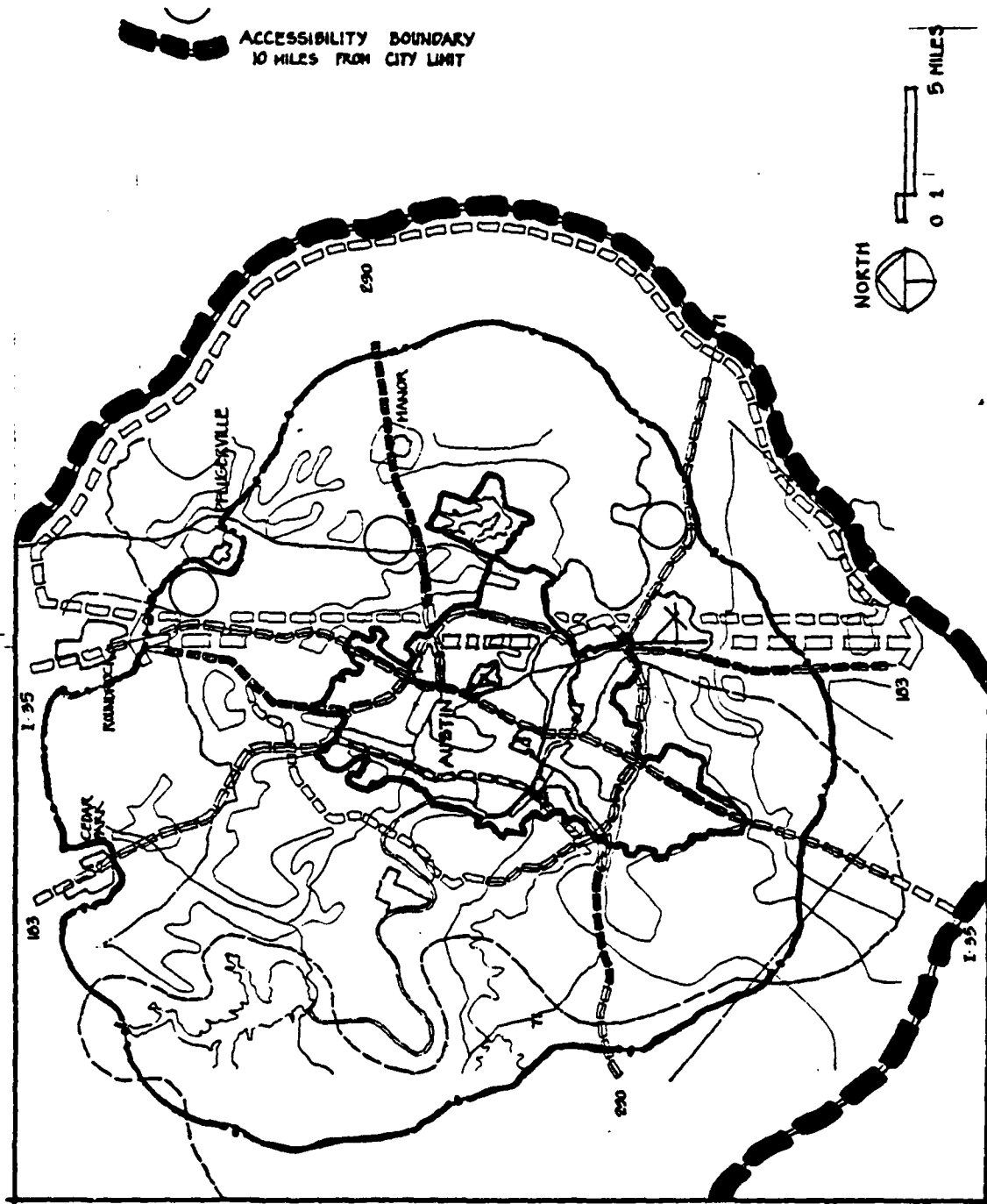

Figure V-3 Base Map C

SUITABILITY ZONE

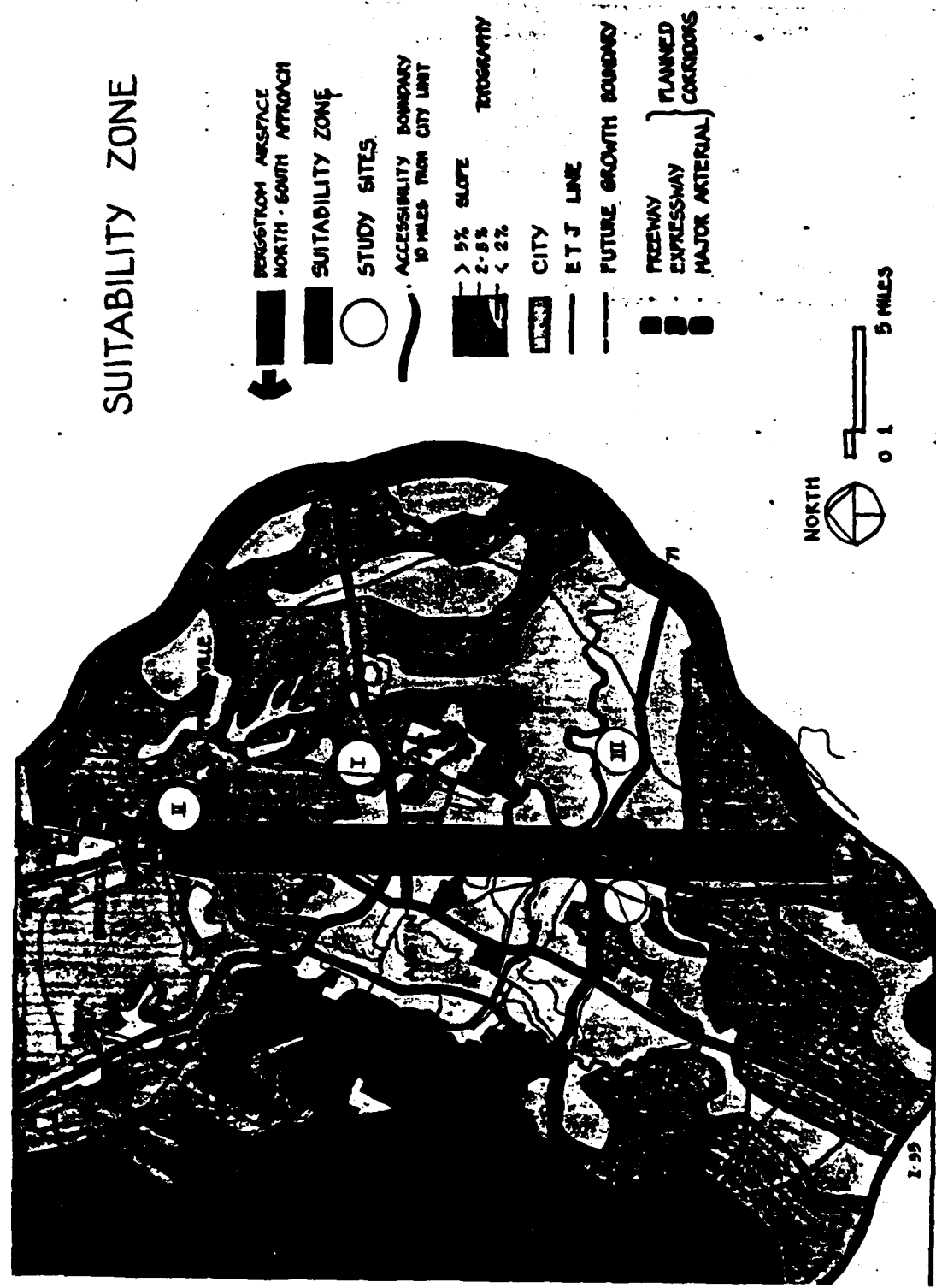

Figure V-4 General Suitability Zone

2. Topography:

The ground slope for Travis County is represented in Figure V-2. Percentage of slope is divided into three ranges: 2%, 2-5% and 5%. The most desirable slope would be 2%. 2-5% may be acceptable and would require attention to runway layout and direction. Ideally the runway slope should be 1/2%.

3. Accessibility

The existing-planned roadways (corridors) for the Austin area are shown in Figure V-3. The accessibility boundary is located 10 miles from the city limits and follows the path of the city's extraterritorial jurisdiction line which extends five miles from the city limits. A more desirable location would be within the accessibility boundary. Close proximity to major routes would be more desirable than remoteness from them. The ability for alternative access becomes important in developing a successful transportation plan.

4. Landuse

All three suggested sites are located within a landuse area described as undifferentiated-urban.³ This may include small towns and villages, commercial, residential, and minor industrial uses. The predominant use is agricultural land. The impact of the new airport

would be conversion of current landuse to a designated commercial or industrial land use annexed by the City of Austin.

5. Expansion

The three sites indicated have sufficient area for properly controlled growth. Consideration of access and future landuse development support a framework for integration of land uses. Sufficient land area must be purchased initially to allow phasing of development and expansions with proper control.

6. Soils

Sites I and III are within the blackland prairie area of Travis County. The soil in this area is classified as a bedrock soil with dark gray, brown, and olive calcareous clays and clay loams, 12-36 inches deep.⁴ Site II is within the rolling prairie area of Travis County. The soil is classified as a bedrock soil with dark brown to gray brown calcareous silty and clay loams, 7-60 inches deep. Neither of these soil conditions is well suited to highway or airport development. Specific site boring investigations could decide what specific engineering and economic constraints exist. Careful soil fill and grading measures would be required to ensure acceptable airport construction.

7. Human Settlement

Outright relocation of existing residences in connection with airport siting should be avoided but when this action is taken it should be evaluated on the basis of cost for acquisition/relocation, property value, and social impact. Sites I and II are close to existing residential areas and impacts on these areas should be evaluated during the environmental impact assessment process.

Overview

The general evaluation of the above factors was intended to further define suitable areas which would support development of a new airport with the additional consideration of compatible land use planning in the urban zone. The resulting sites thus have a range of suitability which can be further evaluated through an environmental impact study. This process should proceed simultaneously with the final site selection study or become an integral part of the site selection methodology. The city's efforts to implement an airport compatible land use plan will benefit the community physically, economically and socially. Airport land use compatibility planning as a general method will be covered more thoroughly in Section VIII.

Although the final site selection and approval may require compromise and ultimately become a political

decision, potential benefits should be measured against present and future 'costs', both social and economic. Currently, final efforts are underway to propose and approve a site for a new air carrier airport in Austin.⁶ A traditional airport development time frame is outlined in Figure. V-5. The resulting success of this process depends upon effective communication and coordination between the airport sponsors, airport consultants, the public, local government and federal government.

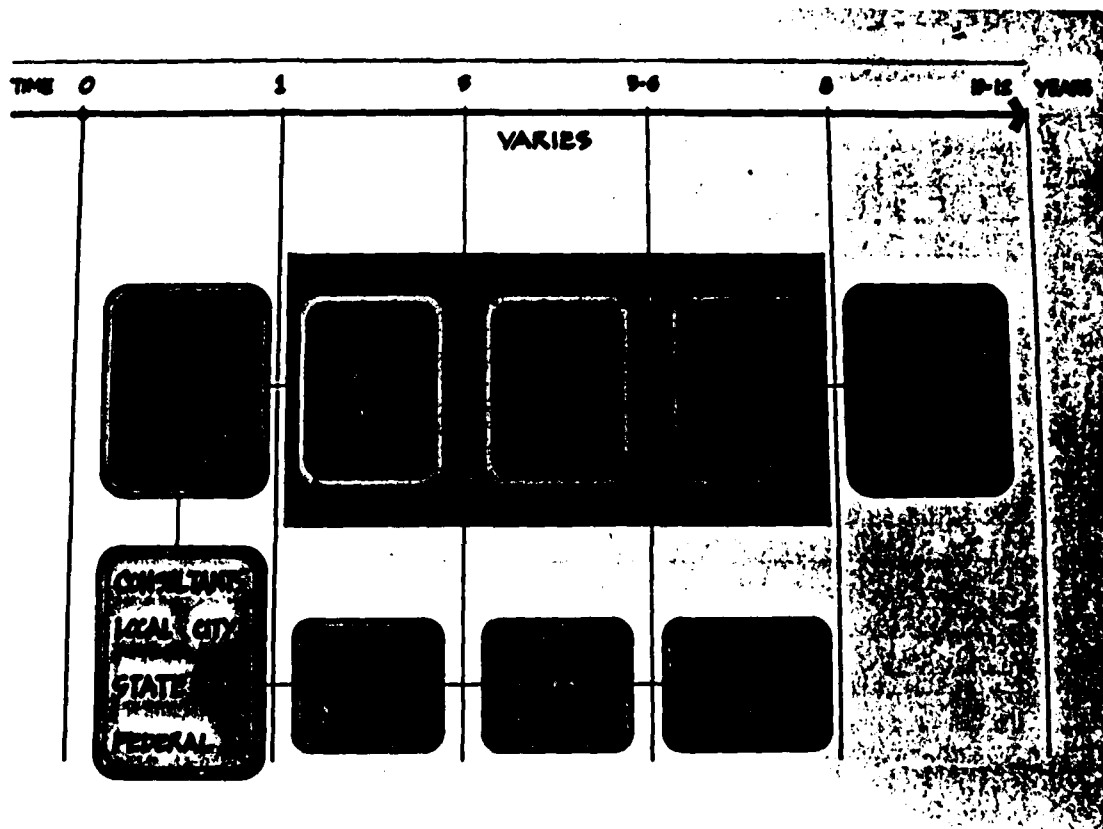

EIAP-Environmental Impact
Assessment Process

Figure V-5 Airport Development Time Frame

FOOTNOTES

1. Horonjeff, Robert, The Planning and Design of Airports, McGraw-Hill Book Company, Inc., 1962, p. 127.
2. "Site Selection Method for a Regional Facility of the Lower Texas Coastal Region", CASAT (Computer-Aided Space Allocation Technique).
3. Bureau of Economic Geology, The University of Texas at Austin, Environmental Geology of the Austin Area: An Aid to Urban Planning. Austin, Texas, 1976, Land Use and Natural Vegetation Map.
4. Ibid, Soil Map.
5. U.S. Department of Transportation, Federal Aviation Administration, Advisory Circular: Land Acquisition and Relocation Assistance. AC No. 150/5100-11, Washington, D.C., February 10, 1975.
6. City of Austin, Texas. Airport Site Selection Study: Air Carrier Airport. Austin Texas: R. Dixon Speas Associates, Aviation Consultants, Los Angeles, California, July 1979.

CHAPTER VI THE NEW AUSTIN AIRPORT--GENERAL CHARACTERISTICS

The recommendation for a new air carrier airport is based upon a future projection of aeronautical demand as developed in a study for a master plan for the Robert Mueller Municipal Airport.¹ The background data and updated forecasts prepared in an aviation impact study were used to support the site selection feasibility in this thesis.² The referenced study documents prepared by R. Dixon Speas were divided into four sections including: Airport Requirements, Site Selection, Airport Plans, and Financial Plans. The overall policy alternatives were recommended as follows:

- A. Accommodate continued general aviation and commercial aviation growth at Robert Mueller Municipal Airport and develop an east-west runway at Bergstrom Air Force Base.
- B. Develop joint use at Bergstrom Air Force Base and reduce the role of Robert Mueller to general aviation.
- C. Develop a new air carrier facility at one of three alternative sites and keep general aviation at Robert Mueller.

- D. Develop a new air carrier and general aviation facility at a new location and close Robert Mueller.³

This study deals with alternative 'C' above and as outlined in the previous section, a broad range of factors was evaluated. The resultant site selection would lead to a "most suitable" site to serve a conventional air carrier airport with expected growth and at the same time increase overall annual operating costs to support both the air service at the new site and general aviation service at Robert Mueller. However, slightly increased operating costs may prove in the long-term to be a more efficient solution for both air carrier and general aviation services. The opportunity for Austin to identify and pursue a new site for commercial air service is timely because the growth in this metropolitan area is occurring at a rate which will support traditional airport planning and development phasing.

Austin's position in the State of Texas is shown in Figure VI-1. The fact that the location and availability of airport facilities is directly related to demand generated by population concentrations can be seen in Figure VI-2. A representation of the attraction power of various air centers in Texas is shown in Figure VI-3. In Austin, enplaned passengers increased from approximately

320,000 in 1973 to 600,000 in 1977.⁴ It is evident that increases in population and distribution will significantly impact air transportation centers. Airport facility modifications and relocation will be necessary to continue to serve the expanding urban areas and improve their regional transportation networks. Significant improvement in air carrier services can be realized through comprehensive and timely planning which at the same time allows suitable growth and integration of airport and community.

Background-Existing Airport Facilities

The City's first "airfield" was a dirt field south of the City, known as Penn Field. Construction of the Austin Municipal Airport was begun in 1929, with a runway 100 feet wide and 1,000 feet long.

The Municipal Airport was dedicated as the Robert Mueller Airport on April 10, 1930, in honor of the city councilman who aided in promoting construction of the new facility.

The second terminal building was constructed in 1942 and served as the main terminal until the present building was completed in 1961. The new terminal area totalled 45,000 square feet. Recent improvements included an enclosed passenger loading concourse with six lounges and loading bridges and expansion of the baggage

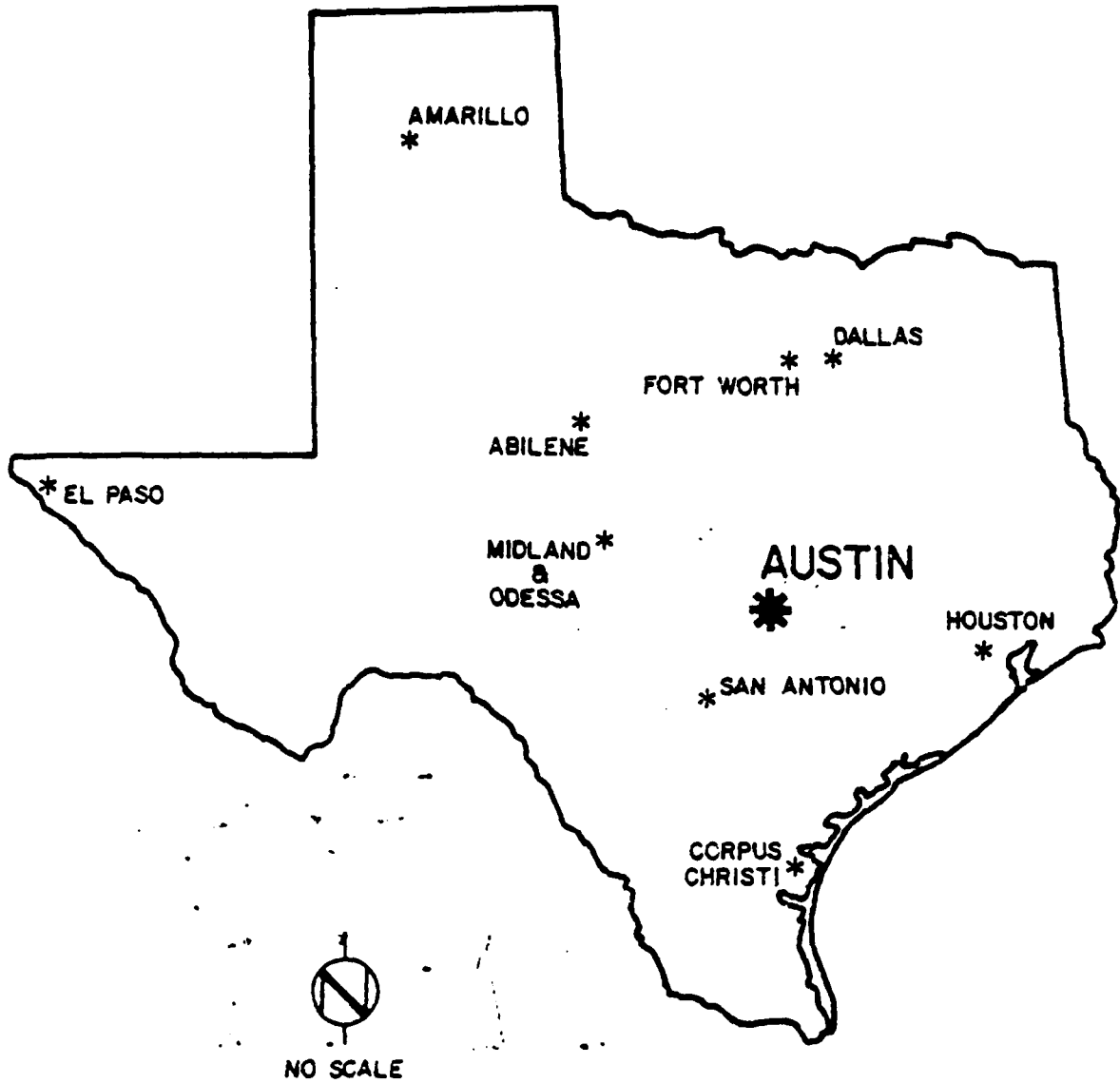
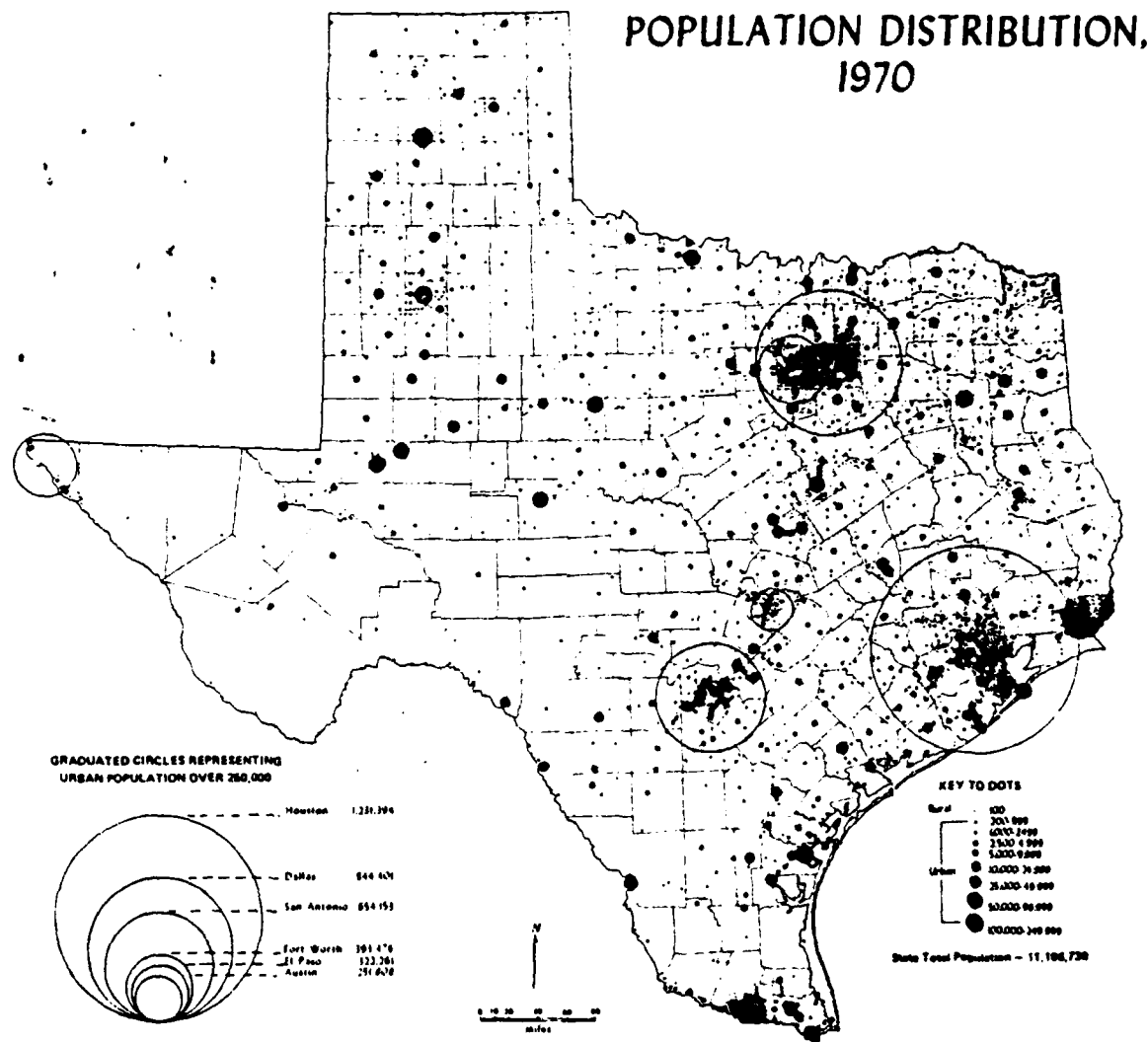

Figure VI-1 Location in State

Source: R. Dixon Speas, Exhibit 3-2, Dec. 1977



Source: Robert S. Hall, "Population Distribution in Texas: Patterns of Population Distribution," Texas Economic Review, June 1972.

Figure VI-2 Population Distribution
Source: Austin Tomorrow Report, Transportation, p. 37.

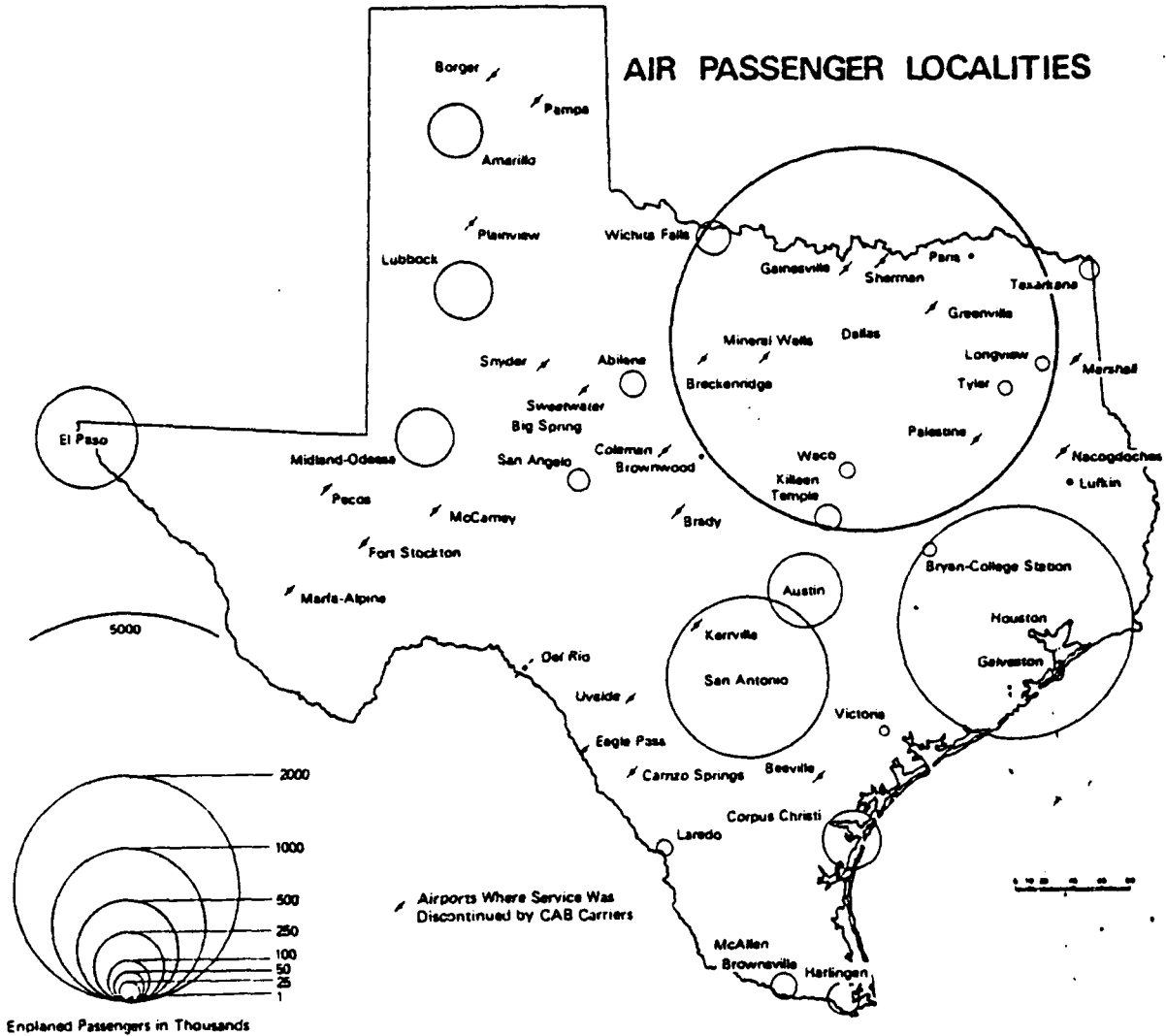

Source: Texas Airport System Plan: Part A, Texas Transportation Institute, College Station, Texas, (1973).

Figure VI-3 Air Passenger Localities in Texas
 Source: Austin Tomorrow Report, Transportation, p. 40

claim area. These improvements increased the total building area to 70,000 square feet.

In 1933, two regularly scheduled airlines, American and Essair, were flying a total of eight flights from Austin daily. Braniff International began service to the City on January 1, 1935. Continental Airlines began serving Austin in June, 1945, as "Pioneer Airlines," and Texas International came to the City in July, 1953, as Trans-Texas Airways. Braniff, Continental, and Texas International continue to serve the Austin airport today. During 1975, the three airlines carried 754,375 passengers to and from the Austin Airport. Southwestern Airlines is a recent addition to service, starting operations in 1977.

Southwest provides shorthaul service to various southwestern states and was certified for service on 29 December, 1976. The City's Department of Aviation was established in 1958 and is responsible for the operation, maintenance, and development of the Municipal Airport. Its overall goal is to provide for the safe, efficient and convenient movement of people and freight to and from the city via air carrier and general aviation aircraft.

The location of the Austin airport is depicted in Figure VI-4. The airport is directly adjacent to U.S. Interstate Highway I-35 which is the primary north-south route in the State of Texas. The primary access

routes to the airport in the City are Manor Road, Airport Boulevard, Martin Luther King Boulevard and the current airport entrance on Pershing Road. The airport is three miles from the central business district and the State Capitol and is centrally located with respect to the Austin Metropolitan Area. The Austin airport is approximately 196 highway miles from Dallas/Fort Worth, 156 miles from Houston, 195 miles from Corpus Christi and 77 miles from San Antonio.

The City of Austin has an estimated population of 325,000 and is expected to grow to a population of 570,000 by 1990⁵. This growth is expected to occur in a number of surrounding urban concentrations. During recent years the growth trend of Austin has been in the northwest and southwest areas of the community. A national study supported general population trends into the year 2000 which will greatly increase the demand for urban land-and-projected within the next 35 years, facilities and housing equal to all which have been constructed since the nation was founded will have to be provided.⁶ Thus well located sites suitable for airport development are going to become increasingly scarce and expensive.

The existing land around Robert Mueller Airport is developed with residential, commercial, and some light industrial uses. The future opportunity for controlling

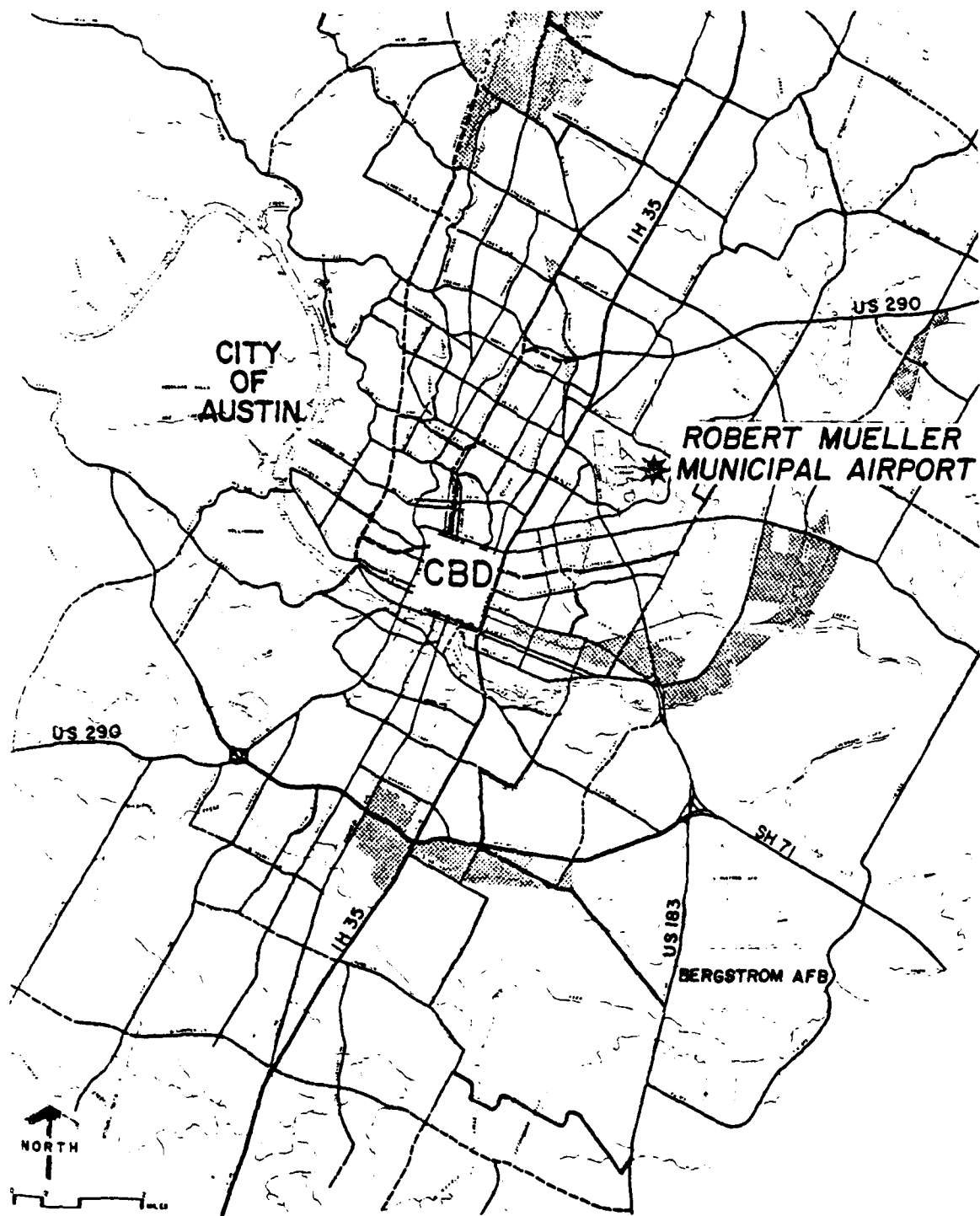

Figure VI-4 Location within Region
Source: R. Dixon Speas, Exhibit 3-1, Dec. 1977

growth in any adjacent areas through compatible land use planning is almost non-existent. Any effort to control development in these areas would occur in the form of a land acquisition program which would be very costly and at the same time this action would not eliminate noise problems generated by future growth and operations of airline traffic.

The current airport layout is presented in Figure VI-5. The present airport site occupies 770 acres. The airfield operating area includes about 547 acres which includes two sets of parallel runways. Land use areas within the airfield include: 1) The Terminal Area (Passenger and cargo terminals, access systems, parking and related support facilities) which occupy 80 acres; 2) the FBO/National Guard area on the east side of the airport which contains 95 acres; and 3) executive terminal area which contains 73 acres on the west side of the airport.

New Airport Configuration

The new airport will be designed to meet FAA specifications for a local or short-haul class airport.

A new high forecast for Robert Mueller prepared in January 1978 estimated 1,000,000 enplanements for 1980 increasing to 2,100,000 enplanements by 1995.⁷ However, there is no assurance that this forecast will be

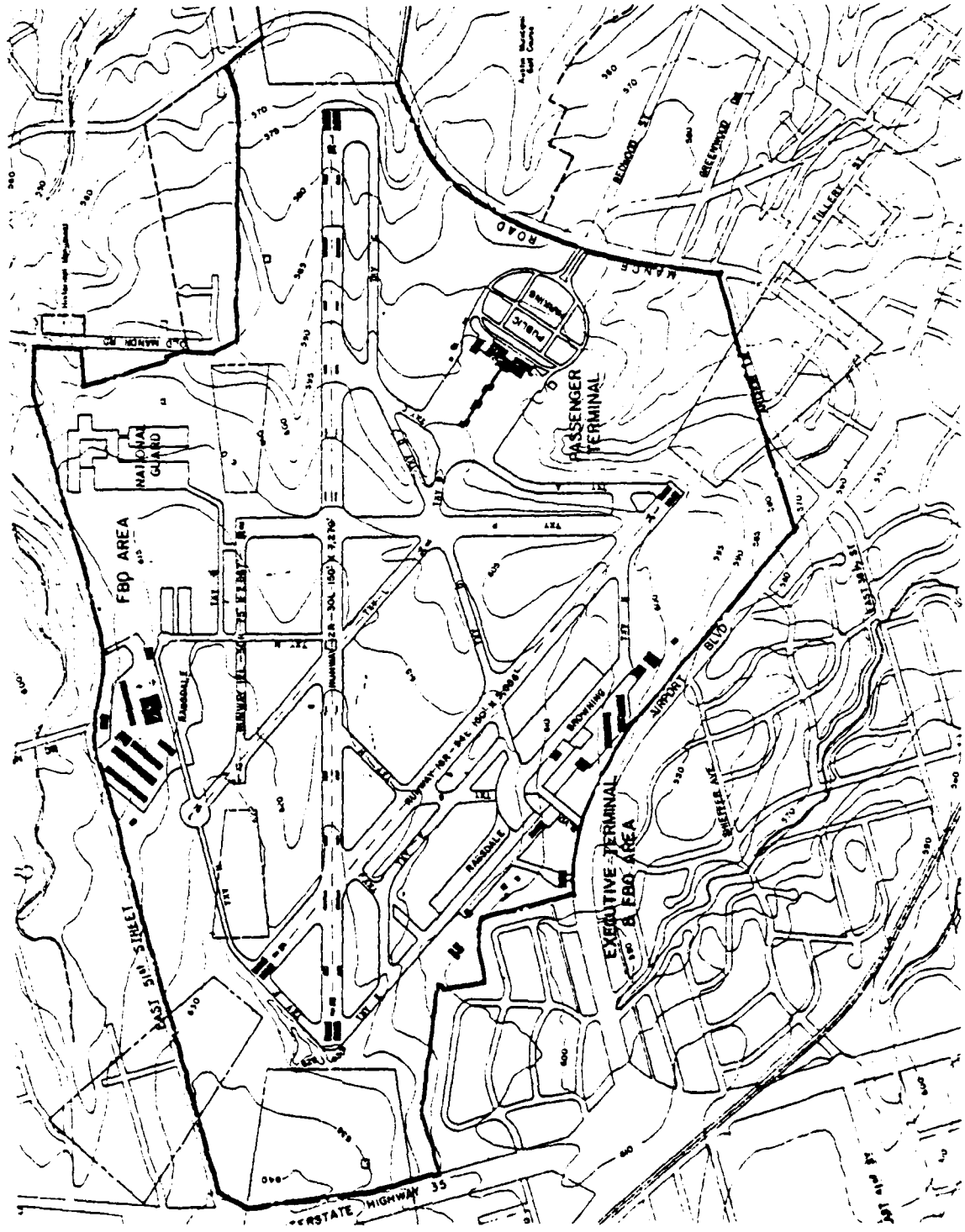

Figure VI-5 Current Airport Site
Source: R. Dixon Speas, DWG No. AUS-1, Dec. 1977

realized. If this forecast is realized the current terminal facilities would have to be tripled in size to handle passengers and cargo. Critical to programming improvements to existing facilities and establishing a transition to the new airport will be further analysis of the intercity growth or air traffic.

The following is a general summary of the criteria for a new airport as outlined in the study prepared by

R. Dixon Speas:

- | | | |
|-------------------|-----------|--------------------------------------------------------------------------------------------------------|
| Number of Runways | - | One with provisions for a parallel runway and crosswind runway if necessary. |
| Runway Lengths | - | Main Runway - 9,000 feet
Major crosswind runway - 7,650 feet
Minor crosswind runway - 4,000 feet |
| Orientation | - | North-South main runways
North-East--Southwest crosswind runway |
| Layout | - | Option A: Close parallel main runways
Crosswind vary with site requirement |
| | Preferred | Option B; Main parallel runways separated by 5,000 feet |

Airport Land Requirements

Aircraft Operation	1,800 acres
Terminal and Support Area	600 acres
Aviation Industry/Commercial	600 acres
Total	3,000 acres
Compatible Land Use	7,000 acres

Total land area of concern when selecting a new site for a new airport is approximately 10,000 acres, as shown in Figure VI-6.

This total area would accommodate a desired minimum area of approximately 3,000 acres for the landing area including the approach and take-off zones and the terminal, cargo, and related support facilities. The appropriate dimensions for the approach and take-off clear zones are established by the Federal Aviation Administration Planning Guidelines. The actual pattern of the compatible landuse area would be outlined and developed under an airport compatibility use plan which ideally becomes a part of the airport master plan. The general importance of compatible use planning will be outlined in Section VII.

General Network Plan

As well as implementation of an airport compatible use plan, the airport system should be designed based upon a general network. The network plan would allow systematic growth and change as well as the application of standardized building techniques in air terminal and supporting building design. The development of an overall airport master plan can be more strategically controlled and implemented to satisfy the three major functional airport elements. This network plan could be developed in phases to satisfy short and long term aviation needs. The network

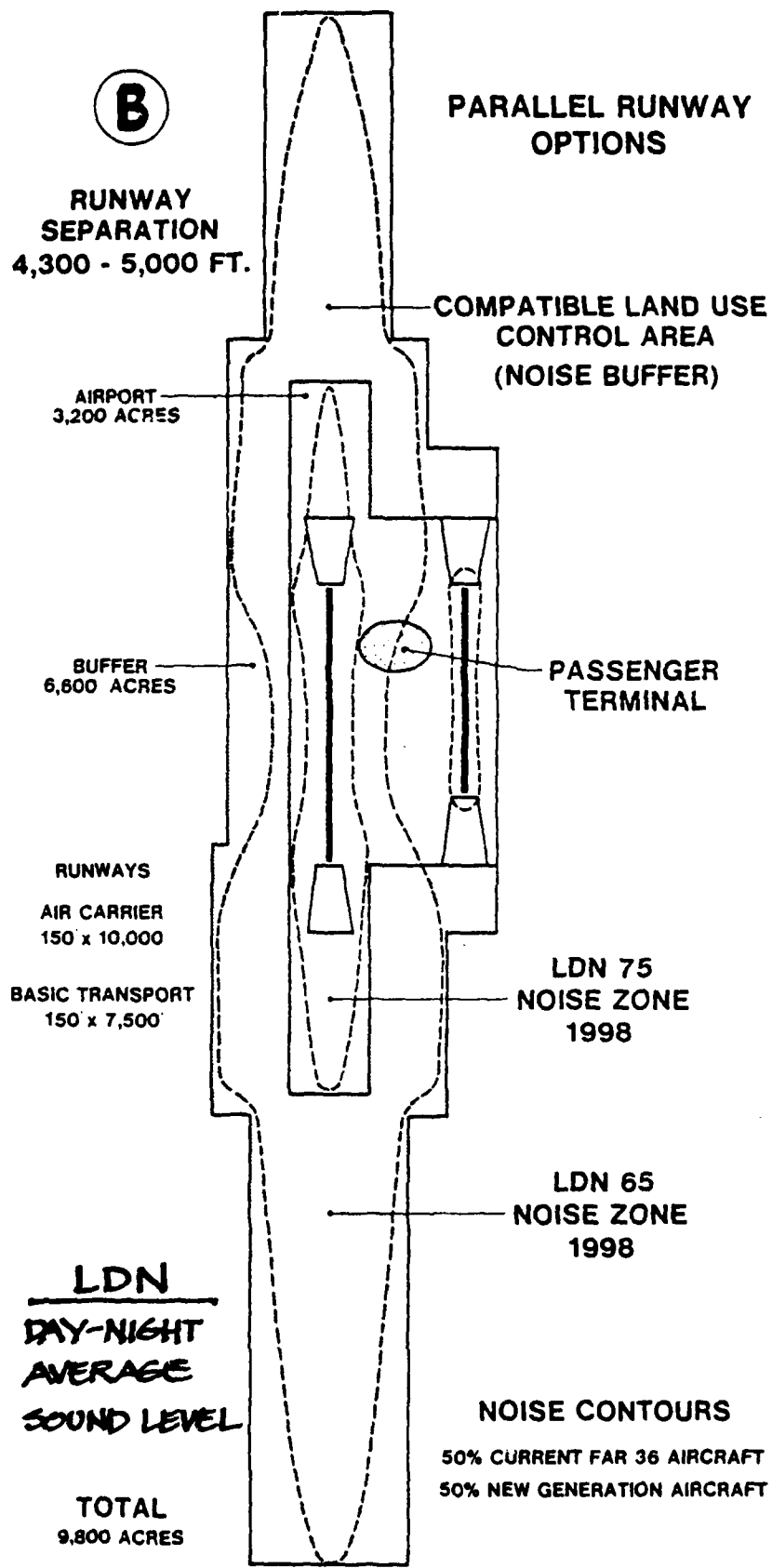

Figure VI-6 Airport Land Requirements
 Source: R. Dixon Speas, Exhibit 5-4, July 1979

plan proposed here would be based upon the 'preferred' airport layout in Figure VI-6. A representative model of this concept is provided in Figures VI-7 (Phase I) and VI-8 (Phase II). The development of the network plan would be preceded by a programming development planning framework. Although a comprehensive programming process is not within the scope of this study, an outline for such a process is provided in Figure VI-9. This framework presents the major influences of planning the airport such as traffic, facilities, operations, environment, environmental effects, and regional aspects. The programming process would proceed with an inventory which leads to a direct compilation of specific criteria and formulation of development plans and design concept. The 'development framework' thus becomes a continuous and instrumental part of the airport 'network' plan.

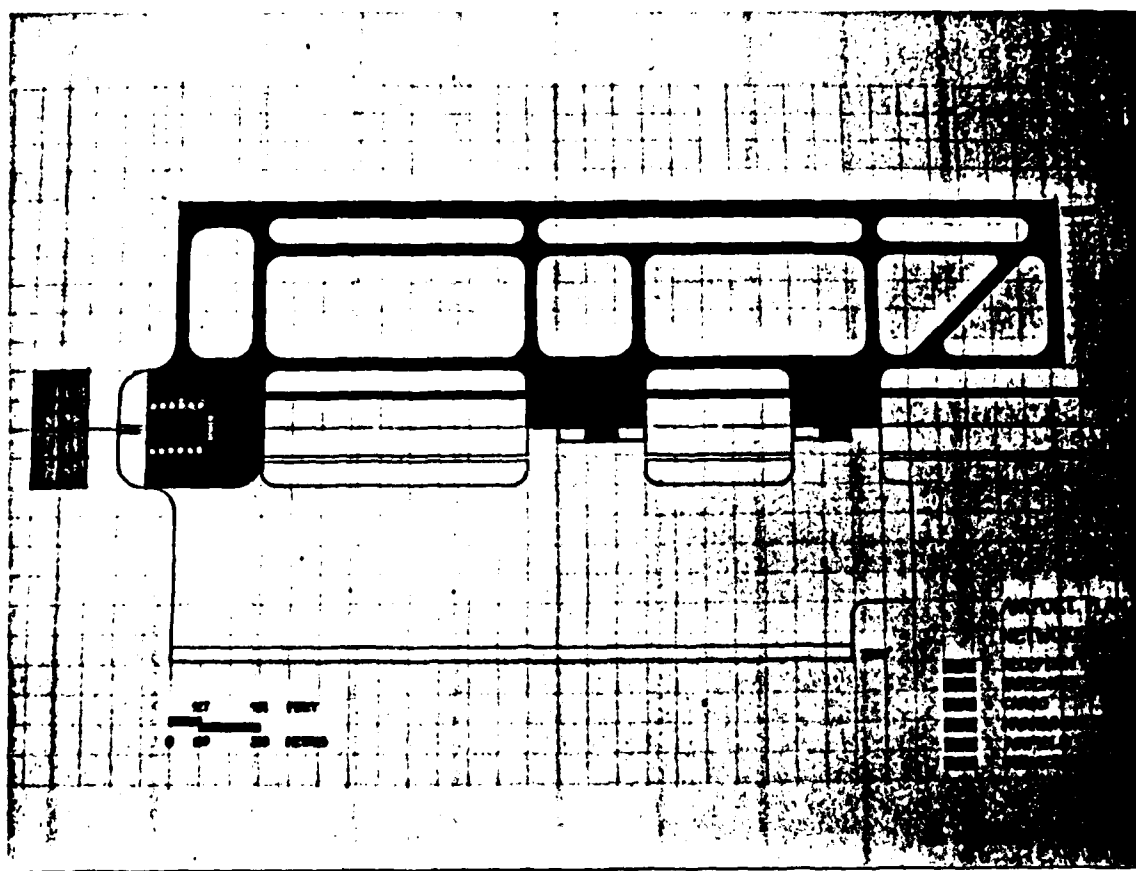

Figure VI-7 General Network Plan-Phase I

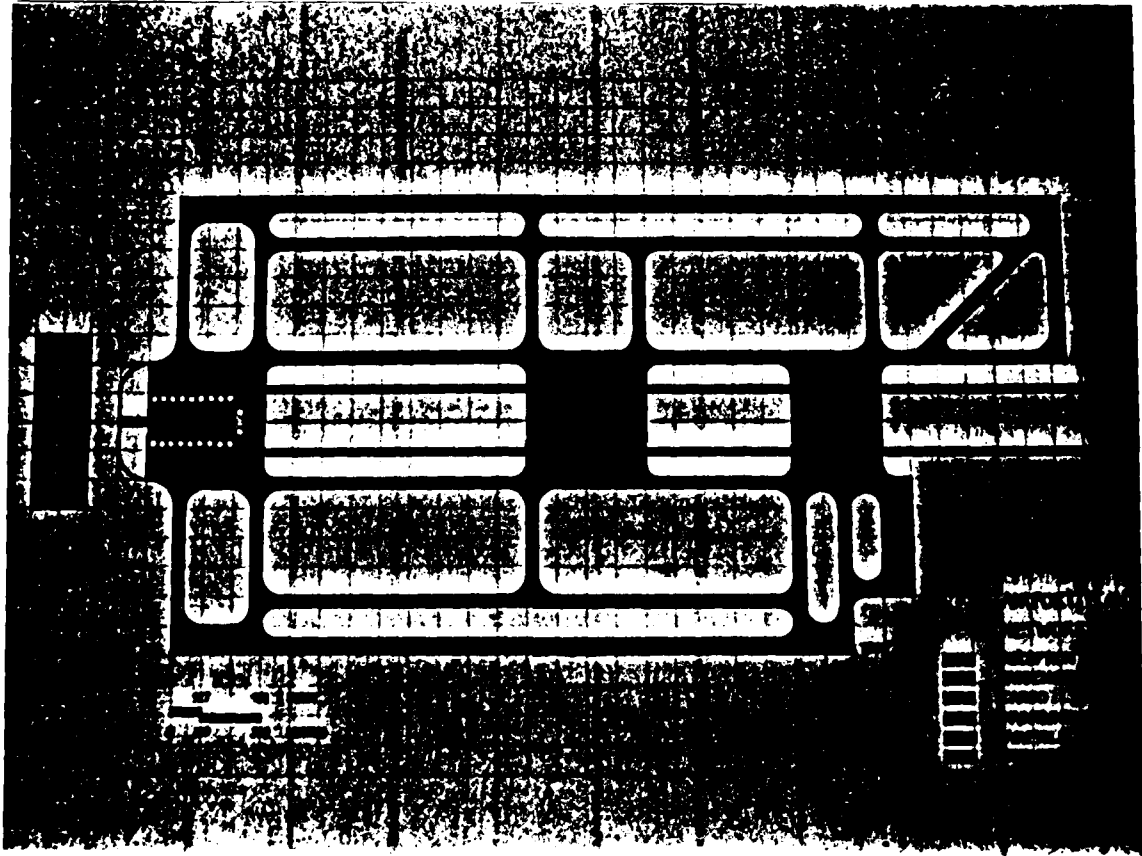

Figure VI-8 General Network Plan-Phase II

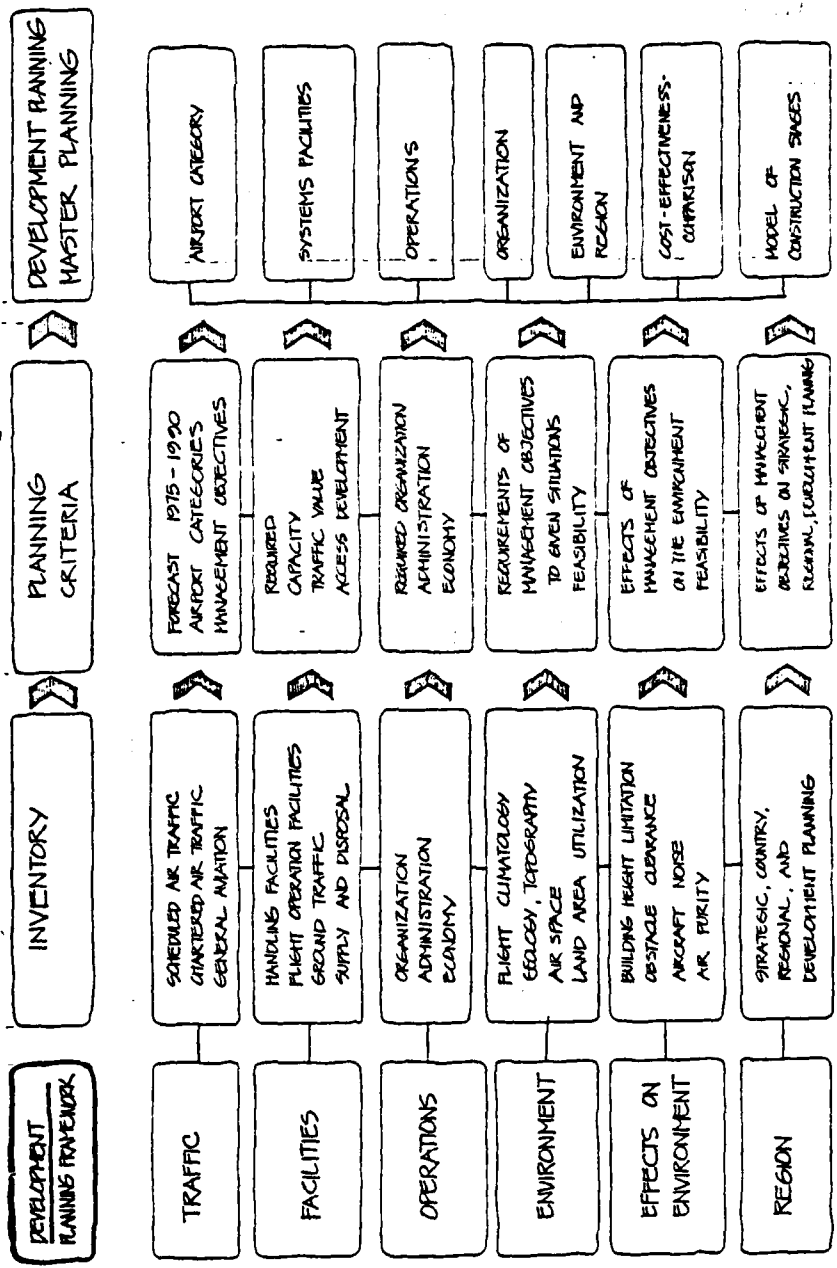

Figure VI-9 Development Planning Framework

FOOTNOTES

1. City of Austin, Texas. Master Plan: Robert Mueller Municipal Airport. Austin, Texas: R. Dixon Speas Associates, Aviation Consultants, December 1977.
2. City of Austin, Texas. Robert Mueller Municipal Airport: Impact of Recent Changes in the Aviation Industry. Austin, Texas: R. Dixon Speas Associates, January 1978.
3. City of Austin, Texas. Airport Site Selection Study: Summary Report, Austin, Texas: R. Dixon Speas Associates, December 1975.
4. City of Austin, Texas. Robert Mueller Municipal Airport: Impact of Recent Changes in the Aviation Industry. Austin, Texas: R. Dixon Speas Associates, January 1978. Exhibit 2-5.
5. City of Austin, Texas. Airport Site Selection Study; Air Carrier Airport, Austin, Texas: R. Dixon Speas Associates, July 1979, pp. 4-6.
6. Arthur D. Little, Inc. "Airport Land Needs", Arthur D. Little, Inc., 25 Acorn Park, Cambridge, Mass., 1966.
7. City of Austin, Texas. Robert Mueller Municipal Airport: Impact of Recent Changes in the Aviation Industry. Austin, Texas: R. Dixon Speas Associates, January 1978. pp. 1-2.

CHAPTER VII AIRPORT LANDUSE COMPATIBILITY PLANNING

The overall purpose of airport landuse compatibility planning is to provide guidance in the vicinity of developing new and existing airports in order that airport sponsors, local government and airport and urban planners can assist one another to achieve long-term compatibility between airports and the environment. The need for such planning is evident if we desire to balance existing and future airport development with the continuing demand for urban expansion. Also the airport and community interrelationships must be clarified and presented to the public for understanding and support.

Implementation Strategy

Airport landuse compatibility planning means more than merely developing a compatibility plan, it also includes various implementation measures and actions required to achieve compatibility between the airport and the environment. Generally the process would include: the compatibility plan, strategies for official adoption, and procedures for reviewing plans. Briefly, the compatibility plan would include a physical plan and implementation program; normally prepared by the airport sponsor and local planning agencies with inputs from the FAA airport users, and residents in the local area. Strategies for adoption would

include an official plan adoption procedure to aid execution of the plan. Since the urban zone is in a continual state of change a clearly defined periodic review of plans by the airport sponsor and local planning agency would serve to monitor plan implementation and compatibility.

Planning Responsibilities

The underlying responsibility for this planning lies with the airport sponsor and with the local government exercising landuse and development control over areas affected by the airport. Additional responsibility is specified in the Department of Transportation Aviation Noise Abatement Policy and also in the Airport and Airway Development Act of 1970. Through these documents the requirement for airport sponsors receiving federal airport development funds must assure that: "appropriate action, including the adoption of zoning laws, has been or will be taken, to the extent reasonable, to restrict the use of land adjacent to or in the immediate vicinity of the airport to activities and purposes compatible with normal airport operations, including landing and takeoff of aircraft."¹

Citizen Participation

Citizen participation in planning is usually time consuming and difficult to structure and integrate but

when properly accomplished will reduce eventual controversy and increase public support for overall plans and implementation strategies.

Financial Assistance

The overall development and implementation of a compatibility plan is no doubt expensive and time consuming, however, financial assistance is available through the Federal Government;² and usually planning is accomplished by integrating landuse planning with the development of a complete airport master plan.

Land Use Guidance System

A land Use Guidance System is presented in Figure VII-1. This system establishes quality zones which can be related to a comprehensive list of land use categories which are presented in Figure VII-2. This system can be used to structure planning inputs for a comprehensive plan. A typical large airport configuration with landuse guidance zones is represented in Figure VII-3. This generalized model must be adapted to the specific airport-community situation. The land use guidance technique along with planning inputs described in Section V are integrated into the airport/urban planning process.

LAND USE GUIDANCE CHART I: AIRPORT NOISE INTERPOLATION									
LAND USE GUIDANCE ZONES (LUG)	NOISE EXPOSURE CLASS	INPUTS: AIRCRAFT NOISE ESTIMATING METHODOLOGIES					HUD NOISE ASSESSMENT GUIDELINES	SUGGESTED NOISE CONTROLS	
		L _{dn} DAY-NIGHT AVG. SOUND LEVEL	NEF NOISE EXPOSURE FORECAST	CNR COMPOSITE NOISE RATING	CNEL COMMUNITY NOISE EQUIVALENT LEVEL				
A	MINIMAL EXPOSURE	0	0	0	0	0	"CLEARLY ACCEPTABLE"	NORMALLY REQUIRES NO SPECIAL CONSIDERATIONS	
		TO 55	TO 20	TO 90	TO 55	TO 55			
B	MODERATE EXPOSURE	55	20	90	55	55	"NORMALLY ACCEPTABLE"	LAND USE CONTROLS SHOULD BE CONSIDERED	
		TO 65	TO 30	TO 100	TO 65	TO 65			
C	SIGNIFICANT EXPOSURE	65	30	100	65	65	"NORMALLY UNACCEPTABLE"	NOISE EASEMENTS, LAND USE, AND OTHER COMPATIBILITY CONTROLS RECOMMENDED	
		TO 75	TO 40	TO 115	TO 75	TO 75			
D	SEVERE EXPOSURE	75	40	115	75	75	"CLEARLY UNACCEPTABLE"	CONTAINMENT WITHIN AIRPORT BOUNDARY OR USE OF POSITIVE COMPATIBILITY CONTROLS RECOMMENDED	
		HIGHER	HIGHER	HIGHER	HIGHER	HIGHER			

Figure VII-1 Landuse Guidance Chart
 Source: FAA Booklet AC 150/5050-6, p. 12

LAND USE		LUG ZONE	LAND USE		LUG ZONE	LAND USE		LUG ZONE
SLUCM NO.	NAME	SUS- GESTED	SLUCM NO.	NAME	SUB- GESTED	SLUCM NO.	NAME	SUS- GESTED
10	Residential	A-B	30	Manufacturing (continued) 2		60	Services 4	
11	Household units	A	31	Rubber and miscellaneous plastic products—manufacturing	C-D	41	Finance, insurance, and real estate services	B
11.11	Single units—detached	A	32	Stone, clay, and glass products—manufacturing	C-D	42	Personal services	D
11.12	Single units—semi-detached	A	33	Primary metal industries	D	43	Business services	B
11.13	Single units—attached row	A	34	Fabricated metal products—manufacturing	D	44	Repair services	C
11.21	Two units—side-by-side	A	35	Professional, scientific, and consulting instruments, photographic and optical goods, watches and clocks—manufacturing	B	45	Professional services	B-C
11.22	Two units—one above the other	A	36	Miscellaneous manufacturing	C-D	46	Contract construction services	C
11.31	Apartments—walk up	B-C	37	Transportation, communication, and utilities		47	Governmental services	A-B
11.32	Group quarters	B-C	38	Pathroad, rapid rail transit, and street railway transportation		48	Miscellaneous services	A-C
12	Residential hotels	A-B	39	Motor vehicle transportation	D	70	Cultural, entertainment, and recre- ation	
13	Mobile home parks or courts	B	40	Aircraft transportation	D	71	Cultural activities and nature estab- lishments	A
14	Transient lodgings	A	41	Marine craft transportation	D	72	Public assembly	A
15	Other residential	A	42	Highway and street right-of-way	D	73	Amusements	A
20	Manufacturing 3	C-D	43	Automobile parking	D	74	Recreational activities 5	B-C
21	Food and kindred products—manu- facturing	C-D	44	Utilities	D	75	Resorts and group camps	A-C
22	Texile mill products—manufacturing	C-D	45	Other transportation, communication, and utilities	A-D	76	Parks	A-C
23	Apparel and other finished products made from fabrics, leather, and similar materials—manufacturing	C-D	46	Trade 4		80	Other cultural, entertainment, and recreational 6	A-B
24	Lumber and wood products (except furniture)—manufacturing	C-D	50	Wholesale trade		81	Resource production and extraction	
25	Furniture and fixtures—manufac- turing	C-D	51	Retail trade—building materials, hard- ware, and farm equipment	C-D	82	Agriculture	C-D
26	Paper and allied products—manufac- turing	C-D	52	Retail trade—general merchandise	C	83	Agricultural related activities	C-D
27	Printing, publishing, and allied in- dustries	C-D	53	Retail trade—food	C	84	Forestry activities and related services	D
28	Chemicals and allied products—man- ufacturing	C-D	54	Retail trade—automotive, marine craft, aircraft, and accessories	C	85	Fishing activities and related services	D
29	Petroleum refining and related indus- tries 3	C-D	55	Retail trade—apparel and accessories	D	86	Mining activities and related services	D
			56	Retail trade—furniture, home furnish- ings, and equipment	C	90	Other resource production and extrac- tion	C-D
			57	Other retail trade	C-D	91	Undeveloped land and water areas (including noncommercial forest development)	D
			58			92	Undeveloped and wooded land areas (excluding noncommercial forest development)	D
			59			93	Noncommercial forest development	A-B
						94	Water areas	A-B
						95	Vacant floor areas	A-B
						96	Under construction	A-B
						97	Other undeveloped land and water areas 7	A-B

1 REFER TO LAND USE GUIDANCE CHART I, PAGE 12
 2 ZONE "C" SUGGESTED MAXIMUM EXCEPT WHERE EXCEEDED BY SELF GENERATED NOISE
 3 ZONE "D" FOR NOISE PURPOSES. OBSERVE NORMAL HAZARD PRECAUTIONS
 4 IF ACTIVITY IS NOT IN SUBSTANTIAL, AIR-CONDITIONED BUILDING, GO TO NEXT HIGHER ZONE
 5 REQUIREMENTS LIKELY TO VARY —
 INDIVIDUAL APPRAISAL RECOMMENDED
 6 SLUCM—STANDARD LAND USE CODING MANUAL, SEE PARAGRAPH 8

Figure VII-2 Landuse Categories
 Source: FAA Booklet, AC 150/5050-6, p. 14

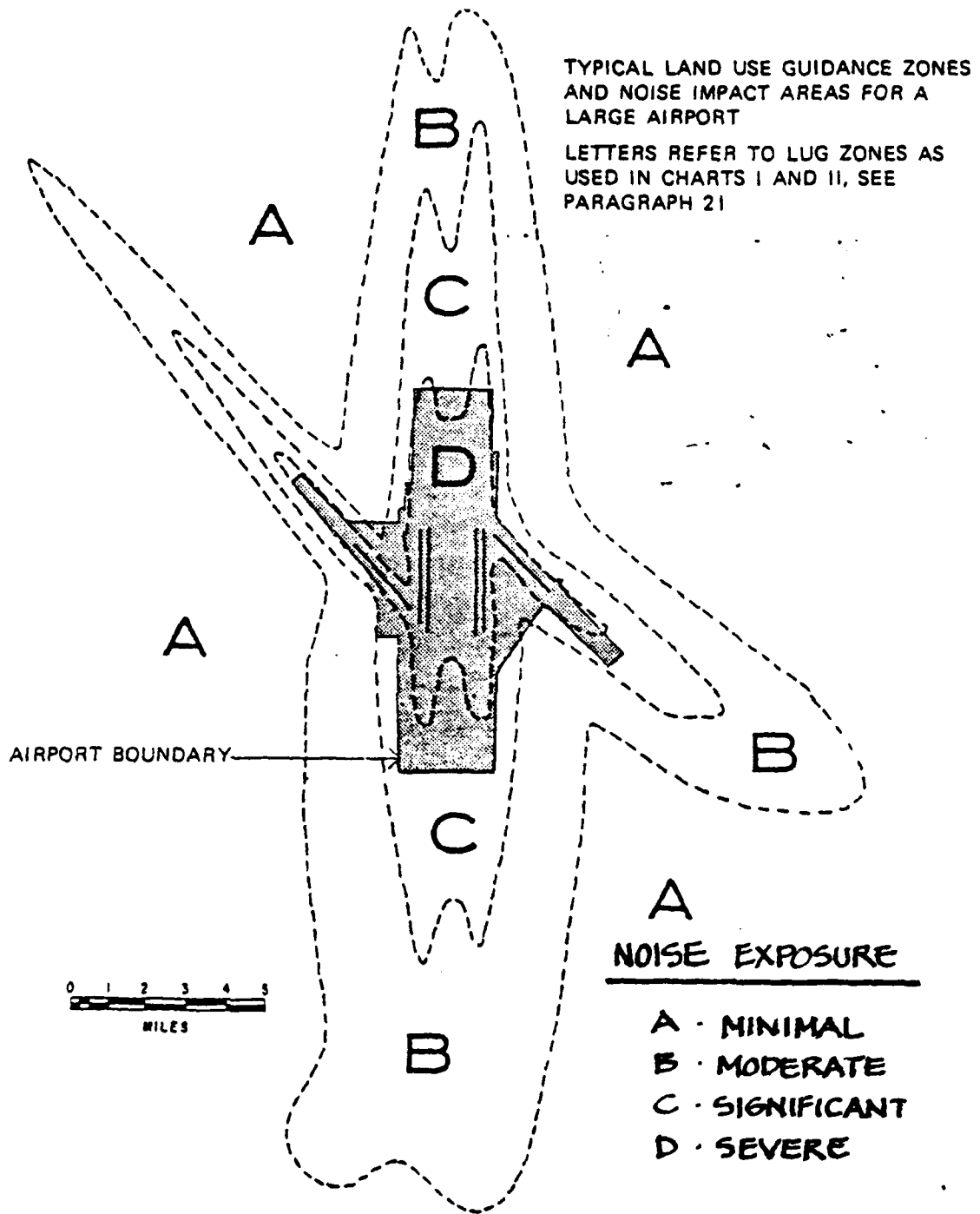

Figure VII-3 Typical Landuse Zones
 Source: FAA Booklet, AC 150/5050-6, p. 16

The Air Installation Compatible Use Zone (AICUZ) Concept

A similar approach to the process outlined above is the AICUZ concept which has been developed by the United States Air Force which is an on-going process to achieve compatibility on and around military air installations. The overall goal of this program is to improve existing and future landuse planning adjacent to military air installations to ensure proper health, safety and comfort of area users and efficient air operations at the installations. The AICUZ system determines compatibility through the use of a sophisticated method of projecting, mapping, and defining aircraft noise and accident hazards in the air base environs.³

At the heart of the resulting compatible plan are four noise zones (ranging from the most severe nearest the runway, to the least severely noise-impacted areas farther away) and three accident zones. There are thirteen possible combinations of these two factors (noise and accident potential) in the AICUZ procedure, and these combinations each form a compatible use district (CUD) which possesses distinct characteristics as to noise and accident potential. The air force has developed recommended land use guidelines for the types of activities that should be allowed in each CUD. The AICUZ concept thus represents a method of quantitatively determining appropriate and compatible land

use controls around air fields. This program would also be suitable for joint use airfields where military and commercial operations occur at the same location.

Other Examples

Two other examples of compatible use planning are shown in Figure VII-4 and Figures VII-5A and Figure VII-5B. The concept in Figure VII-4 is proposed as an airport in a park which addresses some economic and environmental problems facing today's airport authorities. Noise-related operations are placed in the center of a 'park' which acts as a noise-buffer. Within the park would be an airport oriented city containing residential areas, office buildings, hotels, shopping complexes which would also provide additional source of revenue for airport authorities. Figure VII-5 represents a proposal for a modular airport expansion network. Again consideration for compatible land use is seen as a method for providing long-term use in the context of urban growth. The designers suggest that the modular expansion could be based upon a primary land use module containing only the basic airport functions (runway, taxiway, apron, transfer and parking facilities for passengers, air cargo, maintenance, and ground transport system). A secondary land use ring would surround the airport and be developed for related uses such as motels,

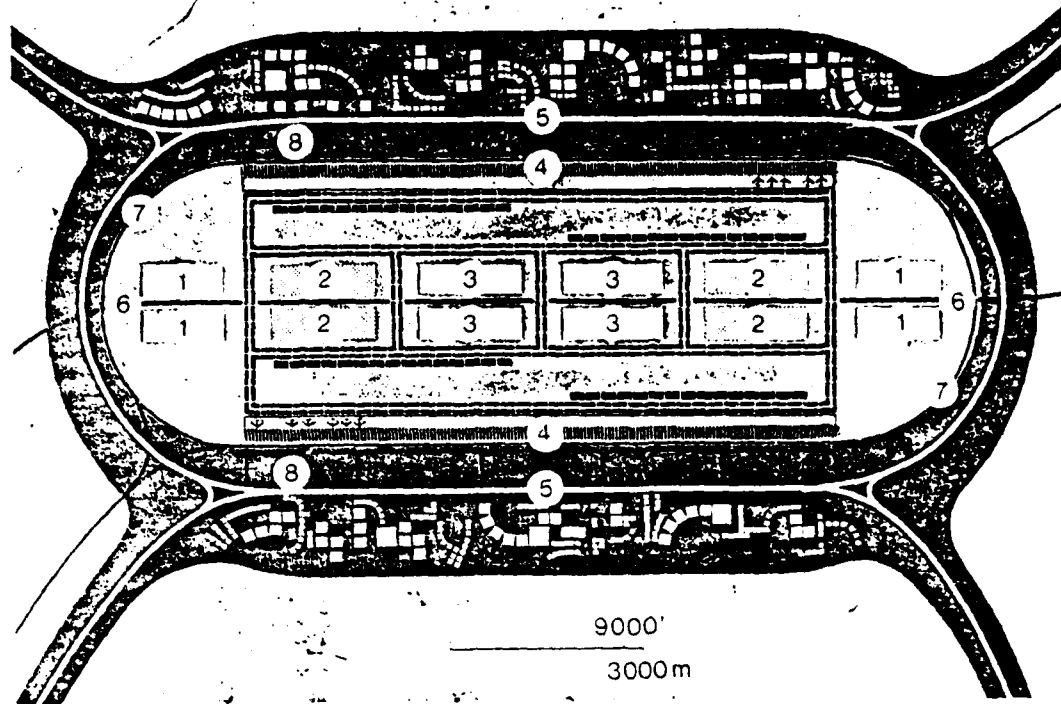

1. Airport In a Park, project; Parkin Architects, Engineers, Planners. The concept provides some answers to the economical and environmental problems facing today's airport authorities. The airport's internal functions as well as other noise-related operations would be located in the center of a spacious park which acts as a noise-buffer. Within the park would be an airport-orientated city containing residential areas, office buildings, hotels and shopping complexes which would theoretically become a new-found source of revenue for airport authorities. Key: 1 commercial and industrial areas, 2 aircraft maintenance, 3 air cargo, 4 passenger terminal, 5 automobile roadway, 6 commercial service roadway, 7 rapid transit, 8 parking.

1. «Flughafen in einem Park» Der Entwurf von Parkin Architects, Engineers, Planners ist ein Versuch zur Lösung der Umweltprobleme und wirtschaftlichen Schwierigkeiten, denen die Flughafenverwaltungen heute gegenüberstehen. Die internen Flughafenfunktionen sowie lärmreiche Industrie- und Gewerbebereiche werden durch einen weitläufigen Grüngürtel isoliert, der als Lärmschirm dient. Im Park selbst liegt eine flughafenorientierte Stadt mit Wohngebieten, Bürogebäuden, Hotels und Einkaufszentren, die gleichzeitig neue Einnahmequellen für die Flughafenverwaltung erschließen könnte. Legende: 1 Industrie- und Gewerbegebiet, 2 Flugzeugwartung, 3 Luftfracht, 4 Passagierterminal, 5 Schnellstraße, 6 Straße für Güterverkehr, 7 Schnellbahn, 8

Figure VII-4 Airport in a Park

Source: Blankenship, p. 14

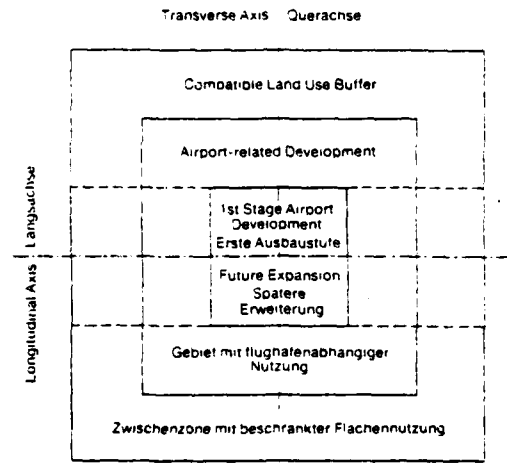
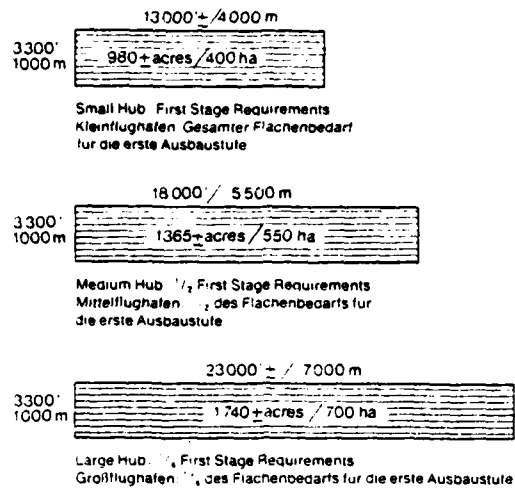

Acreage			
	Small Hub	Medium Hub	Large Hub
Basic Land Use Module	970	2,730	7,000
Future Expansion	970	2,730	7,000
Airport Related Development	4,000	5,800	8,500
Compatible Land Use Buffer	6,000	7,700	9,500
Total Acreage	12,000 ±	19,000 ±	33,000 ±

Figure VII-5A Modular Airport Expansion
 Source: Blankenship, p. 18

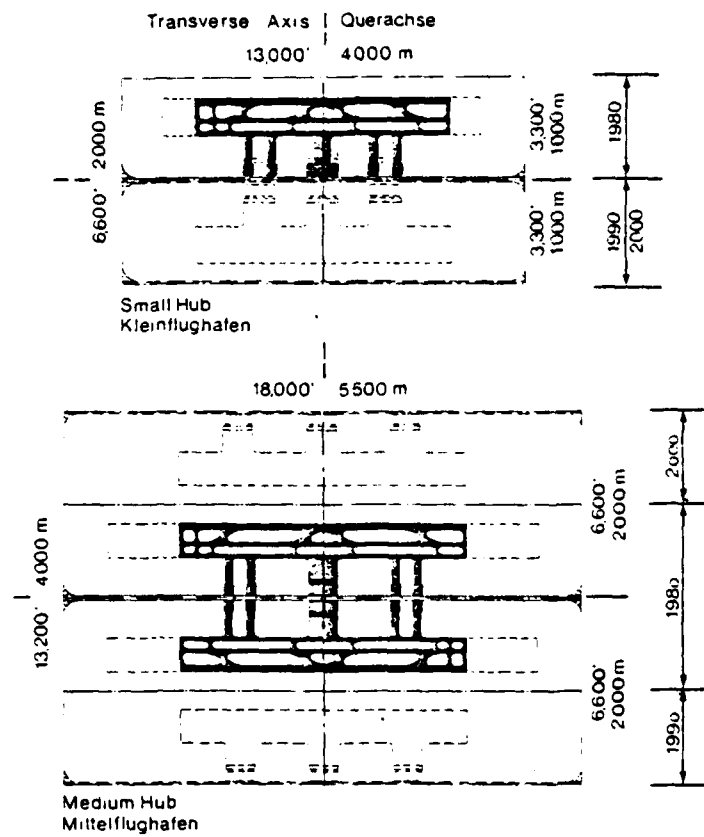

Figure VII-5B Modular Airfield
Source: Blankenship, p. 19

offices, parking, industrial, and various commercial functions. Beyond this a compatible buffer ring of parks and recreation areas would perform as interface between airport and community.

Texas Airport System Plan

Currently studies are being developed by the State of Texas through the Texas Transportation Institute at Texas A&M University in cooperation with the Texas Aeronautics Commission. Various studies are prepared and documented in regional summaries.⁴ The existing Texas Airport System Plan (TASP) is an on-going effort to represent current and future aviation requirements in this State. The TASP incorporates regional planning and provides a basis for continued definitive and detailed master planning. Figure VII-6 represents the organization of the TASP process. Emphasis is also placed on coordinating efforts of federal, state, and local governments in the framework shown in Figure VII-7. Since planning was to organize and present requirements in a clear concept, the existing state planning regions provided a proper means for collecting information and establishing a detailed data base. The organization of planning regions is presented in Figure VII-8.

As stated in the Capital Planning Region Summary, the overall goal of the TASP is to: "Develop and maintain

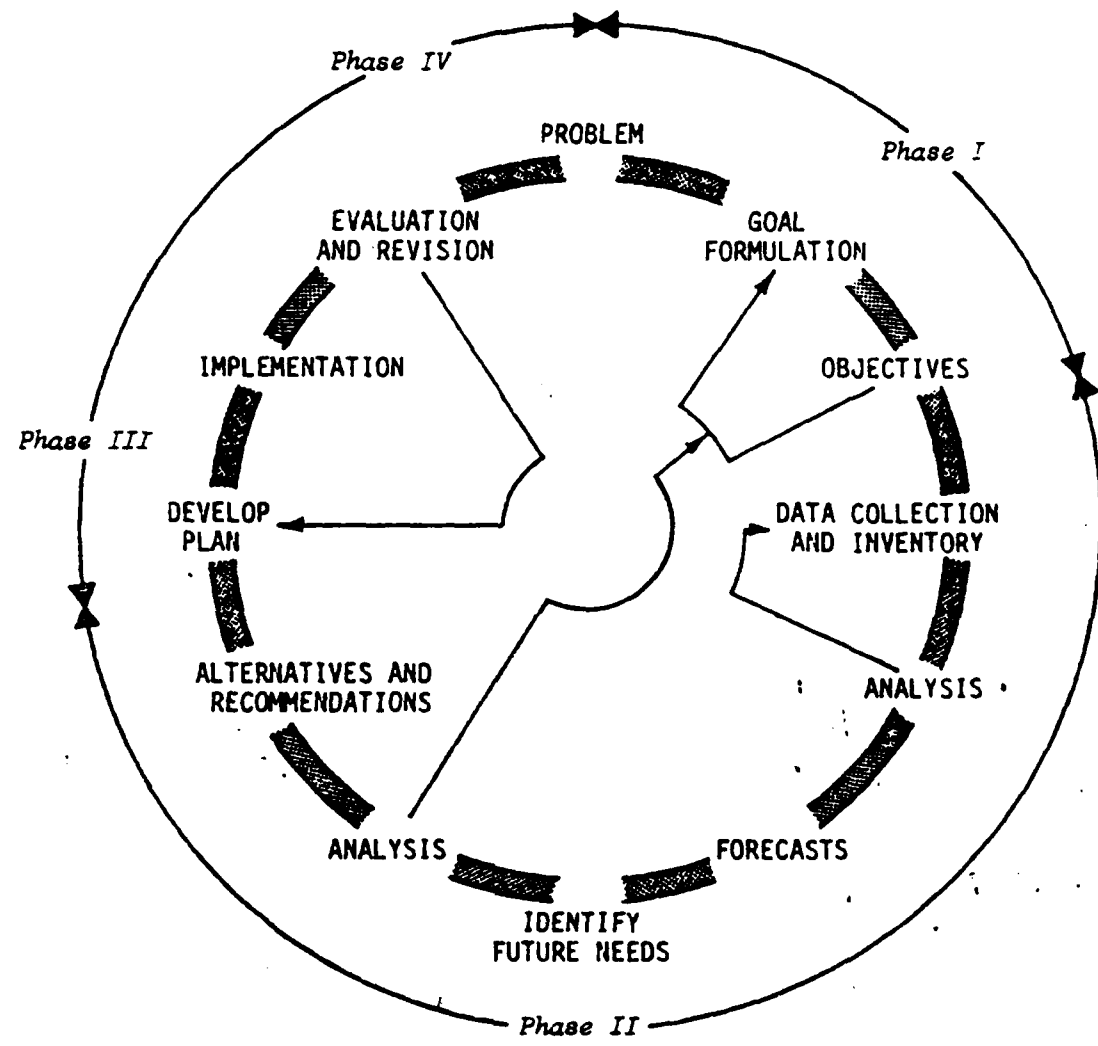

Figure VII-6 TASP Planning Process
Source: TASP, Regional Summary, Capital State Planning Region, p. 2

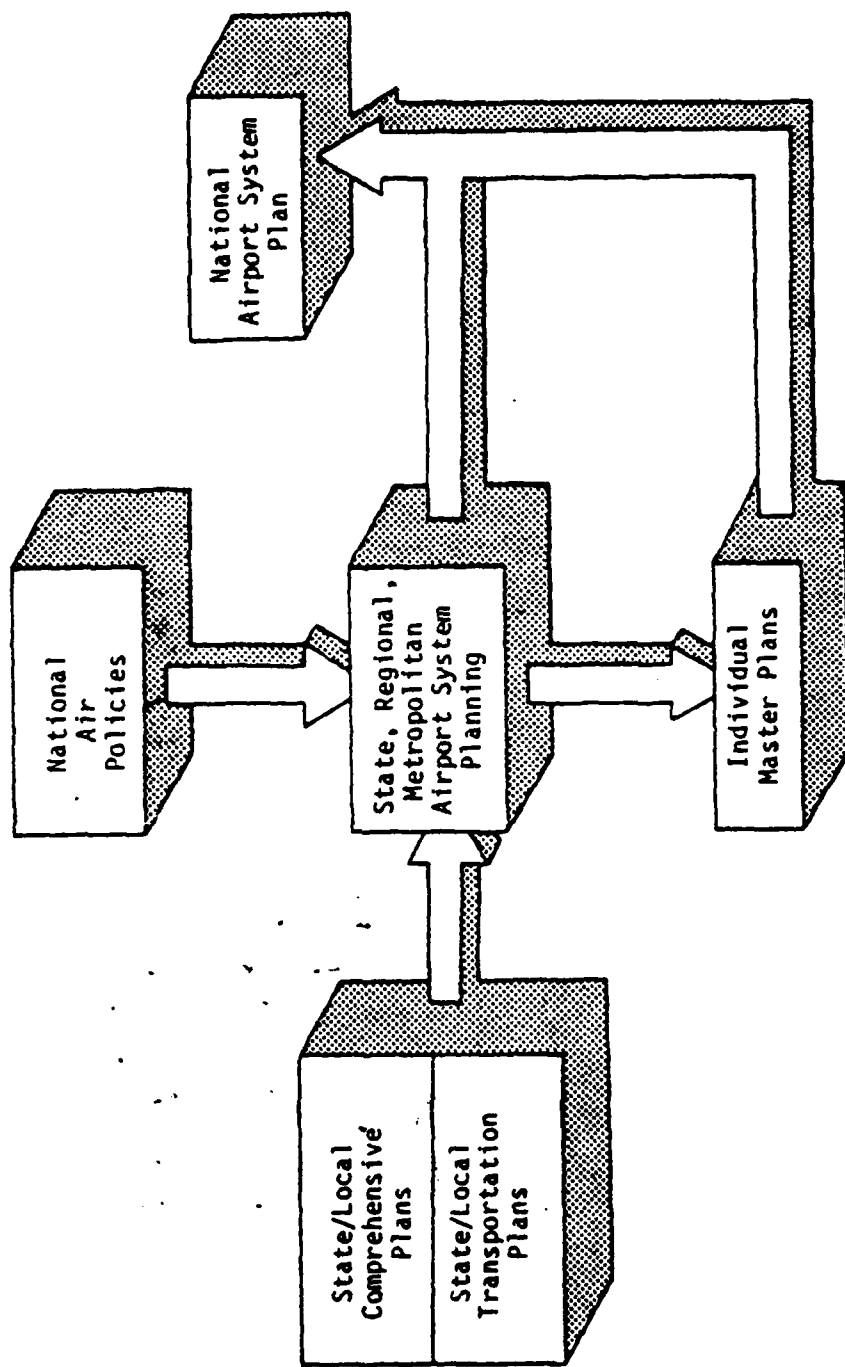

Figure VII-7 Coordination Framework
Source: TASP, Regional Summary, Capital Planning Region, p. 7

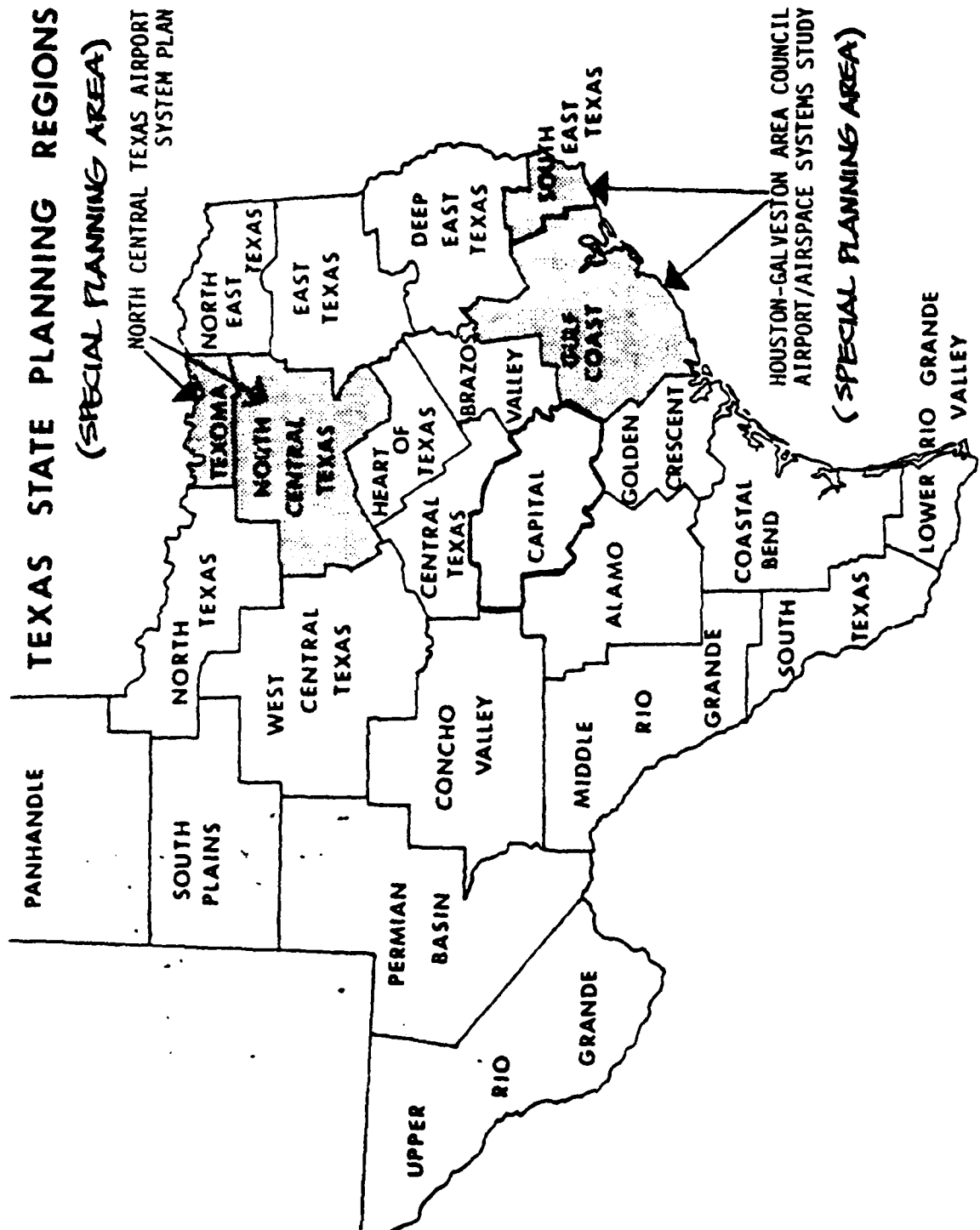

Figure VII-8 State Planning Regions
Source: TASP, Regional Summary, Capital State Planning Region, p. 5

facilities and a level of aviation service by airlines, business, and individuals which, for the least practical cost, will most effectively meet the social and economic goals of Texas".

Some of the more specific goals and objectives are outlined as follows:

- A. Provide reasonable access to scheduled air passenger transportation.
- B. Provide facilities to meet the growing aviation demands of our metropolitan areas.
- C. Make direct air access possible between isolated communities and centers of population.
- D. Improve communication and coordination between state and local governments.
- E. Provide air access to recreational areas.⁵

As of October 1975, there were 501 airports in Texas, publicly and privately owned.⁶ Of these airports, scheduled air carrier service was available in 34 Texas cities. The locations are shown in Figure VII-9.

Once a basic inventory of current aviation facilities and services is complete, future requirements for air traffic can be more accurately projected through the on-going process of regional airport planning. The advantages of airport land use compatibility planning are that it can improve development of existing airport layouts as well as provide a framework for development of new airport centers and their surrounding environment.

FOOTNOTES

1. U.S. Department of Transportation, Federal Aviation Administration, Advisory Circular No. AC 150/5050-6: Airport Land Use Compatibility Planning, December 30 1977, pp. 7.
2. U.S. Department of Transportation, Federal Aviation Administration, Advisory Circular No. AC 150/5070-6: Airport Master Plans, Washington, D.C., January 1976.
3. Headquarters, United States Air Force, Environmental Planning Division (USAF/LREV), AICUZ: Environmental Planning Bulletin 9 (Washington, D.C.: March 1976), p. II-9.
4. Texas Transportation Institute in Cooperation with the Texas Aeronautics Commission, Texas Airport System Plan: Regional Summeries, Texas Transportation Institute, Texas A&M University, January 1976.
5. Ibid, pp. 6.
6. Ibid, Capital State Planning Region, pp. 30.

CHAPTER VIII SUMMARY-ALTERNATIVES

Airports as Systems

Airports across the country will face saturation within this century and authorities must eventually face the fact that more airports will have to be built. Increasing mobility in urban areas will continue to disperse residential, manufacturing, and trade activities into the outskirts or metropolitan regions, which also continues a competitive race for developable land. The dilemma of airport siting occurs because ideally, an airport should function as an integral part of the regional transportation system which would require it to be located near major truck, automobile, and rail routes. At the same time, an airport should also be located close to the center of demand in order to be easily reached by all residents, but the closer the airport is to the city, the greater the problems of integration become. Successful airport siting must be an initial step in the planning of an airport facilities network and must be coordinated with a regional development plan in order to satisfy current and long-term aviation requirements. The extensive effort in time and money required to realize compatible master plans in a

region will prove beneficial to all. In the 1960's and earlier 1970's, droves of experts were out hunting airport sites, but they have become gun-shy, almost defeatist.¹ The main reason for those feelings were the growing visibility of 'environmentalists' and their apparent success through legal proceedings to stall or defeat construction efforts at new sites.

This trend will continue until the airport sponsors and planning professionals can integrate overall inputs to produce comprehensive site study process and coordinate their efforts with local and state agencies. Since airport development takes so long to accomplish now is the time to start planning airports as 'systems' which are capable of responding to growth and change while also becoming an integral component of the city, thus finding acceptability in the community at large.

Alternatives for Austin Airport

The current alternatives for accommodating future aviation activity in this city as proposed by R. Dixon Speas Associates, Aviation Consultants are reviewed in the following paragraphs.

A. Joint use of Bergstrom Air Force Base.

Ideally, the most desirable alternative based upon economic and operational feasibility. This

action would require re-routing a segment of highway 183 and construction of a parallel runway at Bergstrom Field. However, this option has been evaluated by the United States Air Force and the request for joint use has been refused based upon conflicts with on-going and future mission capability.²

B. Stay at Robert Mueller

The proposal to stay at Robert Mueller would require construction of an East-West runway at Bergstrom Air Force Base because of existing airspace conflict between these two airfield systems. Even though the airspace conflict is reduced or eliminated the decision to stay at Robert Mueller would compound existing problems of noise and traffic congestion associated with the current airport and surrounding layout.

C. Develop a New Air Carrier and General Aviation Airport and Close Robert Mueller

This option would leave an existing airfield property which would have to be sold and re-developed. Sale of land would provide additional funds for the airport sponsor, yet the value of maintaining this airport for general aviation would outweigh the overall economic gain.

D. Develop a New Aircarrier Airport and Keep General Aviation at Robert Mueller

This option would be slightly more expensive based upon operating costs, yet has the advantage of maintaining general aviation facilities in a most ideal location which will become more suitable with continued growth and demand for that type of service within the 'center' of Austin's demand area. A part of this proposal would include modification of the existing airfield configuration at Robert Mueller for general aviation which would eliminate the air-space conflicts. Strategic placement of the new airport will become the key to successful air carrier service to satisfy the demands in this area into the next century. Along with this effort the City of Austin must initiate a function which can cope with the external problems of urban planning and public relations. The result will be realized in a more beneficial physical and social impact on community and region.

Summary

Austin's Robert Mueller Municipal Airport is not capable of handling forecast air carrier traffic through 1990 and Austin's request to the Department of Defense for

joint use of Bergstrom Air Force Base was denied. This leaves the city with the dilemma of maintaining air carrier service at the existing airport by expanding existing facilities to handle transfer and processing of increasing numbers of passengers or investing in a new air carrier and/or general aviation airport.

This thesis generally traced the historical development of airports, presented a basic classification of airports, briefly discussed future trends in airport development, outlined a suitability 'zone' within the Austin urban context, and stressed the importance of an airport landuse compatible plan approach. The conclusion is evident in the efforts of this community to further develop and maintain a viable city form. A new air carrier airport is required to support the development of this city form in the 1980's and beyond. At the same time, future circumstances which influence this form may vary drastically and require modification of planning techniques and operational procedures for airports. Specifically, aviation forecasts may change due to aircraft operations and hardware, air fares, and fuel supplies. At this point particular changes in future aircraft design and operation cannot be directly translated into airport development concepts. The intensive effort in current development approaches must allow adaptability in physical facilities and operational

programs. This adaptibility can be pursued by developing the new airport as a 'network' plan within the urban zone which can react to growth and change of the city and region. The integration of the general network plan with adjacent land use and land transport systems will provide a base for the required public and private investment in airport and community development. Since the network plan is developed in phases, physical and financial output are controlled to accommodate changes in master planning as well as operational concepts which support aviation activities. The ultimate goal is to expand the capacity of air services by relocating air carrier service to a new site in Austin that is environmentally acceptable to the region.

FOOTNOTES

1. McQuade, Walter, "Airports: The Dark Side of the Travel Boom", Fortune, December 4, 1978, pp. 100.
2. City of Austin, Texas. Airport Site Selection Study: Air Carrier Airport, Austin, Texas: R. Dixon Speas Associates, Aviation Consultants, Los Angeles, California, July 1979, pp 1-3.

BIBLIOGRAPHY

- Blankenship, Edward G., The Airport: Architecture-Urban Integration-Ecological Problems. Praeger Publishers, New York, N.Y., 1974.
- Arthur D. Little, Inc., Airport Land Needs. Arthur D. Little, Inc., 25 Acorn Park, Cambridge, Massachusetts, 1966.
- Cornell University, Office of Regional Resources and Development, A Feasibility Study of a Regional Jetport for Southern New York State, Office of Regional Resources and Development, Ithaca, New York, 1970.
- Horonjeff, Robert, The Planning and Design of Airports, McGraw-Hill Book Company, Inc., New York, N.Y., 1962.
- Goodman, William I. and Freund, Eric C., Principles and Practice of Urban Planning, International City Manager's Association, Washington, D.C., 1968.
- U.S. Department of Transportation, Federal Aviation Administration, Advisory Circular No. 150/5050-6: "Airport Land Use Compatibility Planning", Washington, D.C., December 30, 1977.
- Airport and Airway Development Act of 1970.
- Foster, Joseph A., "The Airport--A Center of Economic Gravity". The International Congress of Transportation Conferences, Washington, D.C., June 1, 1972.
- L'Architecture d'Aufourd'HUI, V. 43 "Airports", No. 156-Juin-Juillet 1971.
- The Bureau of Economic Geology, The University of Texas at Austin, Environmental Geology of the Austin Area: An Aid to Urban Planning. Austin, Texas, 1976.
- U.S. Department of Agriculture, Soil Conservation Service in Cooperation with the Texas Agricultural Experiment Station, Soil Survey of Travis County, Austin, Texas, 1974.
- Texas Transportation Institute in Cooperation with the Texas Aeronautics Commission, Texas Airport System Plan, Texas Transportation Institute, Texas A&M University, College Station, Texas, 1976.

City of Austin, Texas, Austin Tomorrow Technical Report: Landuse. Austin, Texas: City of Austin Planning Department, May 1975.

City of Austin, Texas. Austin Metropolitan Area Roadway Plan, Austin, Texas: City of Austin Planning Department, June 20, 1979.

City of Austin, Texas. Airport Site Selection Study: Air Carrier Airport, Austin, Texas: R. Dixon Speas Associates, Aviation Consultants, Los Angeles, California, July 1979.

City of Austin, Texas. Robert Mueller Municipal Airport: Impact of Recent Changes in the Aviation Industry, Austin, Texas: R. Dixon Speas Associates, January 1978.

City of Austin, Texas. Master Plan: Robert Mueller Municipal Airport. Austin, Texas: R. Dixon Speas Associates, December 1977.

City of Austin, Texas. Airport Site Selection Study: Summary Report, Austin, Texas: R. Dixon Speas Associates, December 1975.

"Airport Development Planning", Progressive Architecture, November 1961, pp. 158.

Pearce, Charles L., Landuse Controls for Civilian Joint Use of Military Installations. The University of Texas at Austin: School of Architecture and Planning, December 1976.

McQuade, Walter, "Airports: The Dark Side of the Travel Boom", Fortune, December 4, 1978, p. 100.

Interview with Mr. Merrill Goodwyn, Aviation Planner, Texas Aeronautics Commission, Austin, Texas; September 5, 1979.

Telephone Interview with Mr. Stan Lou, Aviation Planner, Federal Aviation Administration, District Office, Houston, Texas; 2 August, 1979.

Interview with Mr. Weslie Goheen, Deputy Chief, Radar Approach Control (RAPCON), Federal Aviation Administration, Bergstrom Air Force Base, Texas, 12 October, 1979.

VITA

James Roy Hughes was born in Grand Forks, North Dakota, on March 7, 1950, the son of Edward Larry Hughes and Alice Larson Hughes. After completing his work at Central High School, Grand Forks, North Dakota, in 1968, he entered North Dakota State University at Fargo, North Dakota. He received the degree of Bachelor of Architecture in May 1973. After graduation, he received a commission through the United States Reserve Officers Training Corps and entered active duty with the Air Force as an Architectural Engineering Officer. He has served tours of duty in Washington and Germany. He entered the Graduate School at the University of Texas at Austin in January 1979, under the sponsorship of the Air Force Institute of Technology, and will be reassigned to the Programming Development Office in the Air Force Systems Command at Andrews Air Force Base, in Washington, D.C., following completion of degree requirements. He is a Captain, USAF and a registered Architect in the State of Minnesota.

Permanent Address: 213 North 11th Street
Grand Forks, North Dakota 58201

This thesis was typed by Dottie Bell.