

AD-A105 481

AIR FORCE ACADEMY CO
SUPPLY PERFORMANCE INDICATORS.(U)
AUG 81 S J MONACO, B E ESTERBY
USAF-TR-81-7

F/6 15/5

UNCLASSIFIED

NL

1 of 1
AD A
105 481

END
DATE
FILED
11-81
DTIC

12

LEVEL

USAPA TR 81-7

SUPPLY PERFORMANCE INDICATORS

ADA105481

SALVATORE J. MONACO, MAJOR, USAF

BRIAN E. ESTERBY, MAJOR, USAFR

DTIC
ELECTE
OCT 8 1981
S D
B

AUGUST 1981

FINAL REPORT

APPROVED FOR PUBLIC RELEASE: DISTRIBUTION UNLIMITED



DEFENSE RESEARCH AND ENGINEERING ACADEMY
COLUMBIA, MISSOURI

DAAG-01-81-012

UNCLASSIFIED

SECURITY CLASSIFICATION OF THIS PAGE (When Data Entered)

REPORT DOCUMENTATION PAGE		READ INSTRUCTIONS BEFORE COMPLETING FORM
1. REPORT NUMBER USAFA-TR-81-7	2. GOVT ACCESSION NO. AD-A105481	3. RECIPIENT'S CATALOG NUMBER
4. TITLE (and Subtitle) Supply Performance Indicators.	5. TYPE OF REPORT & PERIOD COVERED Final Report	
		6. PERFORMING ORG. REPORT NUMBER
7. AUTHOR(s) Salvatore J./Monaco, USAF Brian E./Esterby, USAFR	8. CONTRACT OR GRANT NUMBER(s)	
9. PERFORMING ORGANIZATION NAME AND ADDRESS Dept of Mathematical Sciences US Air Force Academy, CO 80840	10. PROGRAM ELEMENT, PROJECT, TASK AREA & WORK UNIT NUMBERS AFILMC 021029	
11. CONTROLLING OFFICE NAME AND ADDRESS Air Force Logistics Management Center Gunter AFS, AL	12. REPORT DATE August 1981	13. NUMBER OF PAGES 56
14. MONITORING AGENCY NAME & ADDRESS (if different from Controlling Office) E1	15. SECURITY CLASS. (of this report)	
15a. DECLASSIFICATION DOWNGRADING SCHEDULE		
16. DISTRIBUTION STATEMENT (of this Report) Approved for public release; distribution unlimited		
17. DISTRIBUTION STATEMENT (of the abstract entered in Block 20, if different from Report)		
18. SUPPLEMENTARY NOTES		
19. KEY WORDS (Continue on reverse side if necessary and identify by block number) Supply performance indicators, operational capability, predictive regression model, causative regression model, time series model		
20. ABSTRACT (Continue on reverse side if necessary and identify by block number) Data from two F-4 wings are examined to determine the relationship between supply performance indicators and measures of operational capability. Pre- dictive regression models and time series models are developed, with some success, to predict levels of operational capability from supply performance indicators. Attempts to develop causative models that would allow the iden- tification of supply performance goals that would result in stated levels of		

DD FORM 1 JAN 73 1473

EDITION OF 1 NOV 65 IS OBSOLETE

Unclassified

SECURITY CLASSIFICATION OF THIS PAGE (When Data Entered)

Unclassified

SECURITY CLASSIFICATION OF THIS PAGE(When Data Entered)

20. Abstract (continued)

operational capability are unsuccessful. This is due to interrelationships among various supply performance indicators and the existence of unmeasurable factors influencing levels of operational capability.

Unclassified

SECURITY CLASSIFICATION OF THIS PAGE(When Data Entered)

SUPPLY PERFORMANCE INDICATORS

Project 021029

Prepared for

Air Force Logistics Management Center
Director of Supply

by

Maj S. J. Monaco, USAF
Department of Mathematical Sciences
USAF Academy, CO

Maj B. E. Esterby, USAFR
F. J. Seiler Research Laboratory
USAF Academy, CO

August 1981

PREFACE

This research was accomplished under a memorandum of understanding between the Air Force Logistics Management Center Directorate of Supply and the USAF Academy Department of Mathematical Sciences, dated 11 December 1980. The AFLMC project number for this work was 021029.

LIST OF TABLES

<u>Table Number</u>		<u>Page</u>
1	Pearson Correlation Coefficient Statistically Significant at $\alpha = .10$ Bergstrom AFB and Moody AFB	5
2	Bergstrom AFB Regression Models ($\alpha = .10$)	18
3	Moody AFB Regression Models ($\alpha = .10$)	19

LIST OF FIGURES

<u>Figure Number</u>		<u>Page</u>
1	Moving Average Model for SUMX - Moody AFB	7
2	Exponential Smoothing Model for SUMX - Moody AFB	8
3	Moving Average Model for SUMX - Bergstrom AFB	9
4	Exponential Smoothing Model for SUMX - Bergstrom AFB	10
5	Actual and Predicted Values of SUMX - Moody AFB	12
6	Actual and Predicted Values of SUMX - Bergstrom AFB	13
7	Actual and Predicted Values of SUMX Using FY Models - Moody AFB	15
8	Actual and Predicted Values of SUMX Using FY Models - Bergstrom AFB	16
9	Forecasts for 6/80 - 12/80 Using Time Series and Weighted Regression Models - Bergstrom AFB	21
10	"Causative" Regression Models for SUMX by FY - Moody AFB	24
11	"Causative" Regression Models for NMCS by FY - Moody AFB	25
12	"Causative" Regression Models for SUMX by FY - Bergstrom AFB	26
13	"Causative" Regression Models for NMCS by FY - Bergstrom AFB	27
14	Causal Path Analysis - Hypothesized Model	30
15	Causal Path Basic Model - Bergstrom AFB, FY 79	31
16	Causal Path Basic Model - Bergstrom AFB, FY 80	32
17	Causal Path Basic Model - Bergstrom AFB, FY 79 & FY 80	33
18	Causal Path Basic Model - Moody AFB, FY 79	34
19	Causal Path Basic Model, Moody AFB, FY 80	35
20	Causal Path Basic Model - Moody AFB, FY 79 & FY 80	36
21	Causal Path Selected Model - Bergstrom AFB, FY 79	38

LIST OF FIGURES (Continued)

<u>Figure Number</u>		<u>Page</u>
22	Causal Path Selected Model - Bergstrom AFB, FY 80	39
23	Causal Path Selected Model - Moody AFB, FY 79	40
24	Causal Path Selected Model - Moody AFB, FY 80	41

SUPPLY PERFORMANCE MEASURES

1. Introduction. The Department of Mathematical Sciences (DFMS) investigated the relationship between supply performance indicators and measures of operational capability for an F-4 wing. Data was provided for this effort from Bergstrom AFB and Moody AFB and covered the period October 1978 through December 1980.

The objectives of this research as stated in a memorandum of understanding between AFLMC and DFMS were as follows:

- a. Identification of measurements of supply performance that are statistically correlated with measures of operational capability.
- b. Determination of appropriate supply performance goals to achieve a stated level of operational capability.

The data which was provided included monthly measures of operational capability as well as monthly indicators of supply performance. The variables examined in this study were as follows:

<u>Operational Capability Level</u>	<u>Explanation</u>
NMCS	non-mission capable rate due to only supply
NMCB	non-mission capable rate due to both supply and maintenance
PMCS	partial-mission capable rate due to only supply
PMCB	partial-mission capable rate due to both supply and maintenance

Our understanding was that these variables were mutually exclusive and thus could be added to form new indicators. The only reason for considering such additional indicators was that they might provide "measures" which can

be better predicted and controlled than the original variables. These pseudo-indicators which we considered were:

$$\text{SUMS} = \text{NMCS} + \text{PMCS}$$

$$\text{SUMB} = \text{NMCB} + \text{PMCB}$$

$$\text{NMCX} = \text{NMCS} + \text{NMCB}$$

$$\text{PMCX} = \text{PMCS} + \text{PMCB}$$

$$\text{SUMX} = \text{NMCS} + \text{NMCB} + \text{PMCS} + \text{PMCB}$$

They may be interpreted as follows:

<u>Pseudo Operational Capability Level</u>	<u>Explanation</u>
SUMS	aircraft capability degraded rate due to only supply
SUMB	aircraft capability degraded rate due to both supply and maintenance
NMCX	non-mission capable rate due to supply
PMCX	partial-mission capable rate due to supply
SUMX	aircraft capability degraded due to supply

Note the difference in capability levels that read "due to supply only" and those "due to supply." These variables were actually expressed in units of percentages, and were based on the percentage of possessed hours that aircraft spent in the respective degraded category during a given month. The only pseudo-indicator that proved of use to us was SUMX and this is the only one which will be discussed in any great detail in this report.

The supply indicator variables were as follows:

<u>Supply Indicator</u>	<u>Description</u>	<u>Units</u>
EOQGA	Gross Availability of EOQ items	Percentage
EOQNA	Net Availability of EOQ items	Percentage
EOQA	EOQ due-outs/reason A	Number of monthly due-outs

EOQB	EOQ due-outs/reason B	Number of monthly due-outs
EOQC	EOQ due-outs/reason C	Number of monthly due-outs
EOQD	EOQ due-outs/reason D	Number of monthly due-outs
EOQTII	Total Inventory Investment for EOQ	Dollar amount

Similar indicator variables were available for reparable items. These variables are similar to the EOQ variables except that their names are preceded by REP instead of EOQ.

2. Search for the Best Predictive Models. We first decided to use multivariate regression analysis to determine the best subset of descriptive variables (i.e., supply indicators) to be used to predict operational capabilities. Although the overall objective was to build a descriptive (i.e., control) model rather than a predictive model, this was run in order to verify some of the results of the Auburn report¹; and at the same time to examine the significant correlations and relationships among the descriptive variables. As mentioned previously, there were fourteen descriptive or explanatory variables which we utilized to build a model. The sum of the "REP" and "EOQ" variables was also supplied as "TOT"; however, using this would have provided no additional information and would have introduced linear relationships among the set of predictor variables. The Auburn report used the EOQ, REP, and TOT variables as separate predictor sets. We saw no reason to do this and in fact combined the EOQ and REP variables into one set since they measure different things.

Of the four raw dependent variables investigated, the best results were obtained with NMCS (the non-mission capable rate due to supply). The other

variables were so inconsistent (in terms of our ability to build a model to predict them) that the results were discarded. The pseudo-indicator with consistent results was SUMX which is the sum of all aircraft degraded (rate) due to supply causes. The remainder of this report will deal with models for these two indicators.

A correlation analysis between the independent variables and the two dependent variables was performed with all 27 observations using the SPSS² package. The Pearson correlation coefficients that were statistically significant at the 10% level (i.e., $\alpha = .10$) are reported in Table 1. This table can be used to prepare a realistic subset of the descriptive variables (supply measures) which can be used to predict NMCS or SUMX in a simple linear multivariate regression model. Note that statistically significant correlation does not imply a cause and effect relationship. In fact several of the correlations intuitively appear to have the wrong sign (these are marked by an asterisk in Table 1). For example the correlation between NMCS and EOQTII for Moody AFB is .4366. The positive coefficient implies that as we increase the amount invested in inventory we will increase the NMCS rate, which is clearly counter-intuitive. This will be discussed in more detail in a later section.

The linear correlations among the independent variables were also examined. As expected the NA and GA variables within each group (EOQ and REP) are highly correlated as are the due out variables (A, B, C, and D). EOQTII and REPTII were also highly correlated. Some unexpected results were that EOQA and EOQB showed highly significant correlations with many of the REP variables. These results were generally the same for both Moody and Bergstrom AFB, although the interrelationships for the Moody data were stronger. These correlations were also examined by each fiscal year. The results are included in a separate addendum to this report - "Computer Listings."

TABLE 1. Pearson Correlation Coefficient Statistically Significant at $\alpha = .10$.
Bergstrom AFB and Moody AFB

	CORRELATION COEFFICIENTS			
	27 Observations - 10/78 - 12/80			
	Bergstrom AFB		Moody AFB	
	NMCS	SUMX	NMCS	SUMX
EOQGA				
EOQNA	0.2995*	0.3187*	-0.2238	-0.2404
EOQA			0.3595	0.4645
EOQB				0.3142
EOQC				
EOQD	-0.4175*		0.2705	0.2626
EOQTII			0.4366*	0.5104*
REPGA	-0.2455	-0.3487	-0.2647	-0.4062
REPNA		-0.3070	-0.2583	-0.3905
REPA			0.4619	0.5272
REPB	0.2525	0.3675		
REPC				
REPD				
REPTII				0.2495*

* Apparent incorrect sign for causal model

These results were examined in order to avoid using highly correlated independent variables together in the same model, thereby keeping the linear correlations among the predictor set as small as possible.

Since the data was provided in the form of a time series, some simple time series models, namely, moving average and single exponential smoothing were fit. The purpose of this was to contrast these results with the regression models that were developed. The single exponential smoothing is simply based on averaging past values of a time series in an exponential manner.

The time series fit was:

$$\hat{SUMX}_{t+1} = \alpha SUMX_t + (1 - \alpha) \hat{SUMX}_t \quad (1)$$

or

$$\hat{SUMX}_{t+1} = \hat{SUMX}_t + \alpha (SUMX_t - \hat{SUMX}_t) \quad (2)$$

The smoothing is achieved by giving exponentially decreasing weights to past observations. Equation (2) shows that the forecast for period $t + 1$ is equal to the forecast for the previous period plus an adjustment which is equal to the error in the previous forecast times the weighting factor α . The value of α which yielded the model with the smallest mean square error (MSE) was chosen.

For the moving average models, the number of terms yielding the smallest MSE were included in the moving average. The model is simply:

$$SUMX_{t+1} = \frac{SUMX_t + SUMX_{t-1} + \dots + SUMX_{t-k-1}}{k} \quad (3)$$

where k is the number of terms in the moving average.

All of the time series results were obtained using the SYBIL/RUNNER time series package³. The results are shown in Figures 1-4. The mean square error (MSE) as well as the mean absolute percentage error (MAPE) are shown on the plots. These plots show both the observed and predicted results using

SUPPLY PERFORMANCE INDICATORS MOODY AFB

MSE = 10.8
MAPE = 15.1%

- OBSERVED DATA
□ 5 TERM MOVING AVERAGE

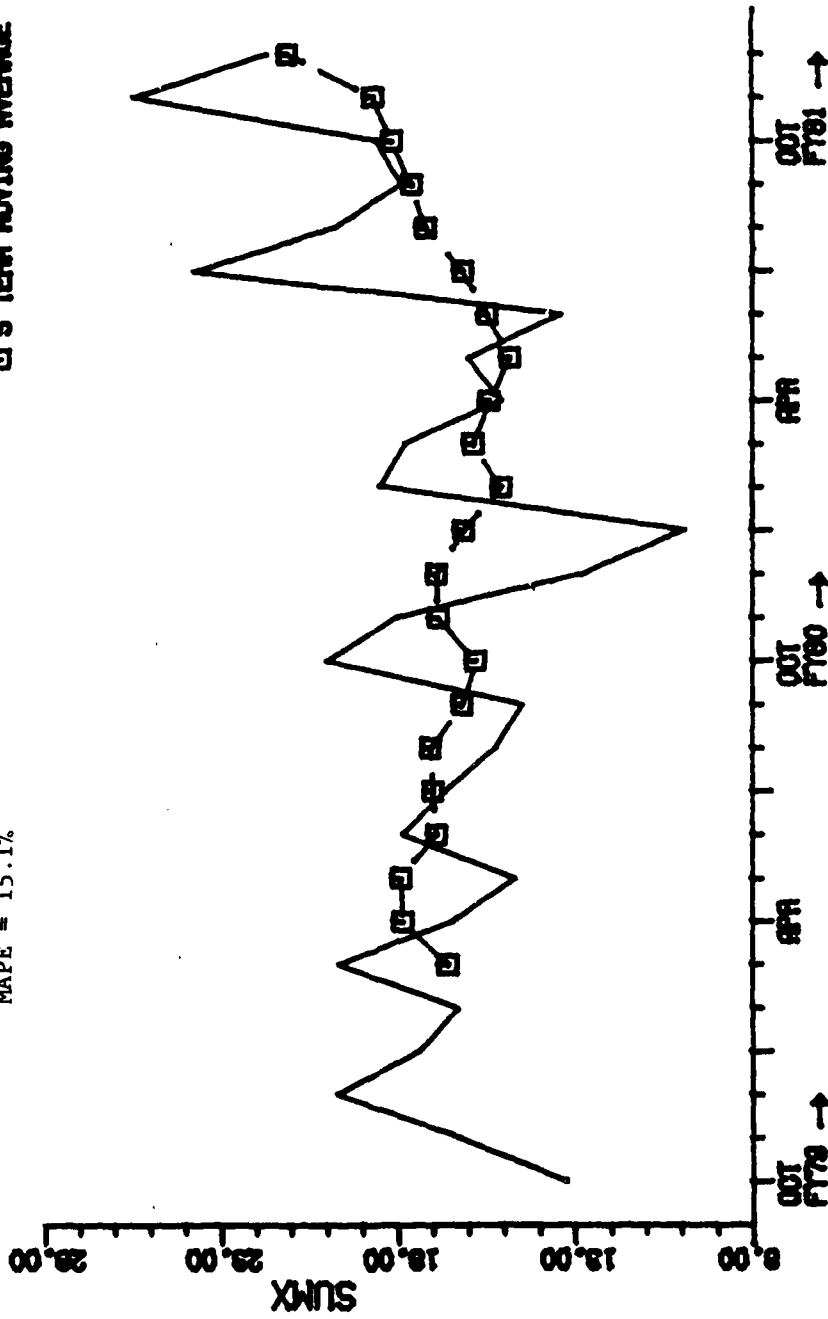

Fig 1. Moving Average Model for SUMX - Moody AFB

SUPPLY PERFORMANCE INDICATORS MOODY AFB

MSE = 11.9
 MAPE = 15.3%
 - OBSERVED DATA
 □ EXPONENTIAL FORECAST ($\alpha = 0.3$)

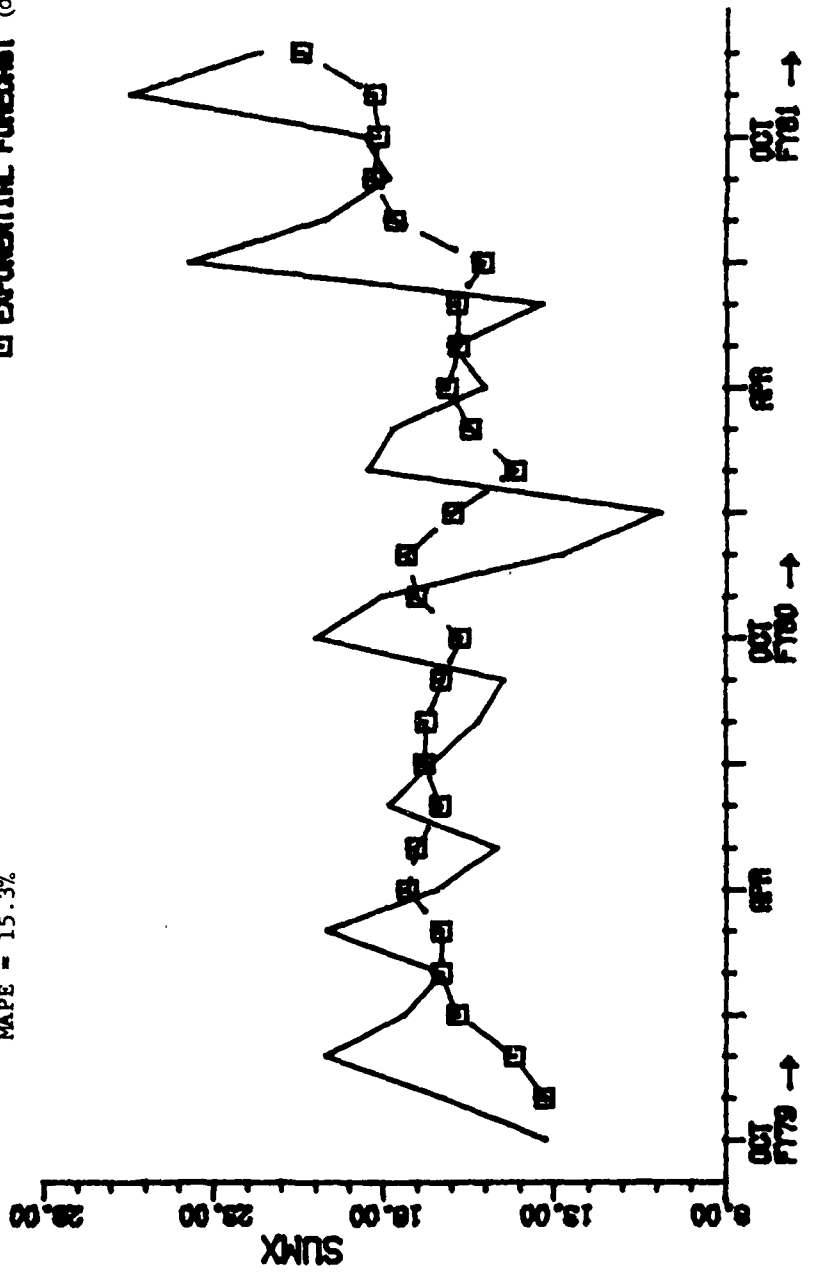

Fig 2. Exponential Smoothing Model for SUMX - Moody AFB

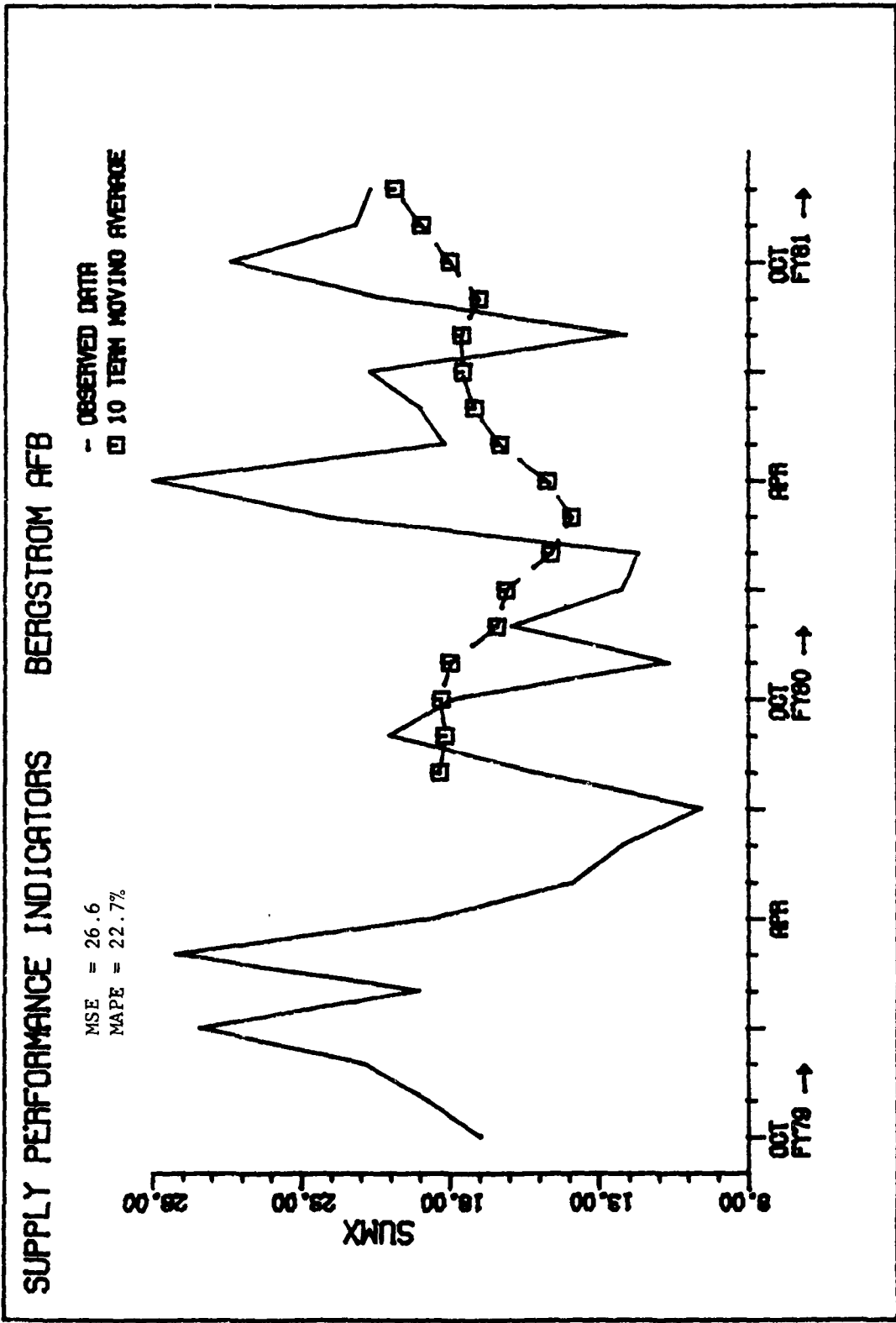

Fig 3. Moving Average Model for SUMX - Bergstrom AFB

SUPPLY PERFORMANCE INDICATORS BERGSTROM AFB

MSE = 27.5
 MAPE = 25.6%

- OBSERVED DATA
 □ EXPONENTIAL FORECAST ($\alpha = 0.1$)

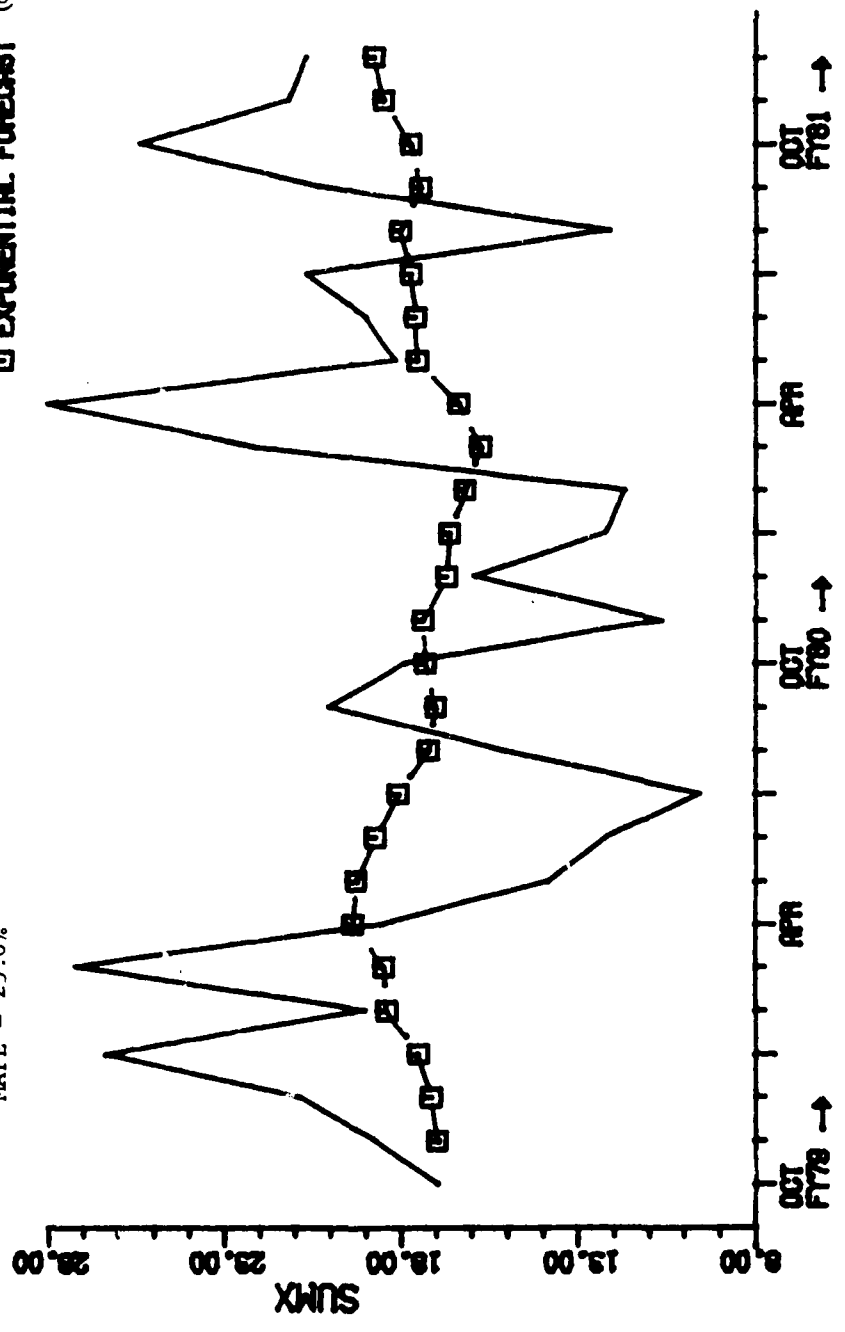

Fig 4. Exponential Smoothing Model for SUMX - Bergstrom AFB

all 27 observations. *

Linear regression models for SUMX were also fit. The results were poor in terms of the amount of variation in the data explained, however, still clearly superior to the time series models as can be seen by comparison with Figures 5 and 6. The respective models are as follows:

$$\text{Moody AFB: } \hat{\text{SUMX}} = 20.08 + .1826 \text{ REPA} - .1063 \text{ REPGA}$$

$$\text{Bergstrom AFB: } \hat{\text{SUMX}} = 49.93 + .1417 \text{ REPB} - .5150 \text{ REPGA}$$

It is interesting to note the similarities in these models. Both use a "REP" due out measure as well as REPGA. The linear correlation between REPA and REPB for the Moody AFB data is 0.5 which is significant at $\alpha = .004$.

The statistical summary of these regressions is given below:

<u>Model</u>	<u>Mean Square Residuals</u>	<u>R²</u>	<u>F</u>
Moody	8.57	0.30	5.11
Bergstrom	20.64	0.26	4.13

The mean square due to residuals compares favorably with the equivalent MSE from the time series models. The standard error is 2.93 for the Moody model and 4.54 for the Bergstrom model. There was no evidence in the residual analysis to suggest transformations of variables. Nonlinear models of the form:

$$\hat{\text{SUMX}} = b_0 \text{ EOQGA}^{b_1} \text{ EOQA}^{b_2} \dots \text{ REPTII}^{b_{14}}$$

were also fit for all observations as well as each fiscal year. These models were discarded since they generally offered no improvement over the simple linear models and are considerably more difficult to interpret. These results are included in the addendum to this report.

Considerably better fits were obtained when models were fit to a specific fiscal year, either FY79 or FY80. The specific FY models were quite different from each other, however, R² values as high as 0.98 could be obtained in this

*Note: Time series models for NMCS were similar to these and are included in the Appendix.

SUPPLY PERFORMANCE INDICATORS MOODY AFB

- OBSERVED DATA
 □ REGRESSION MODEL

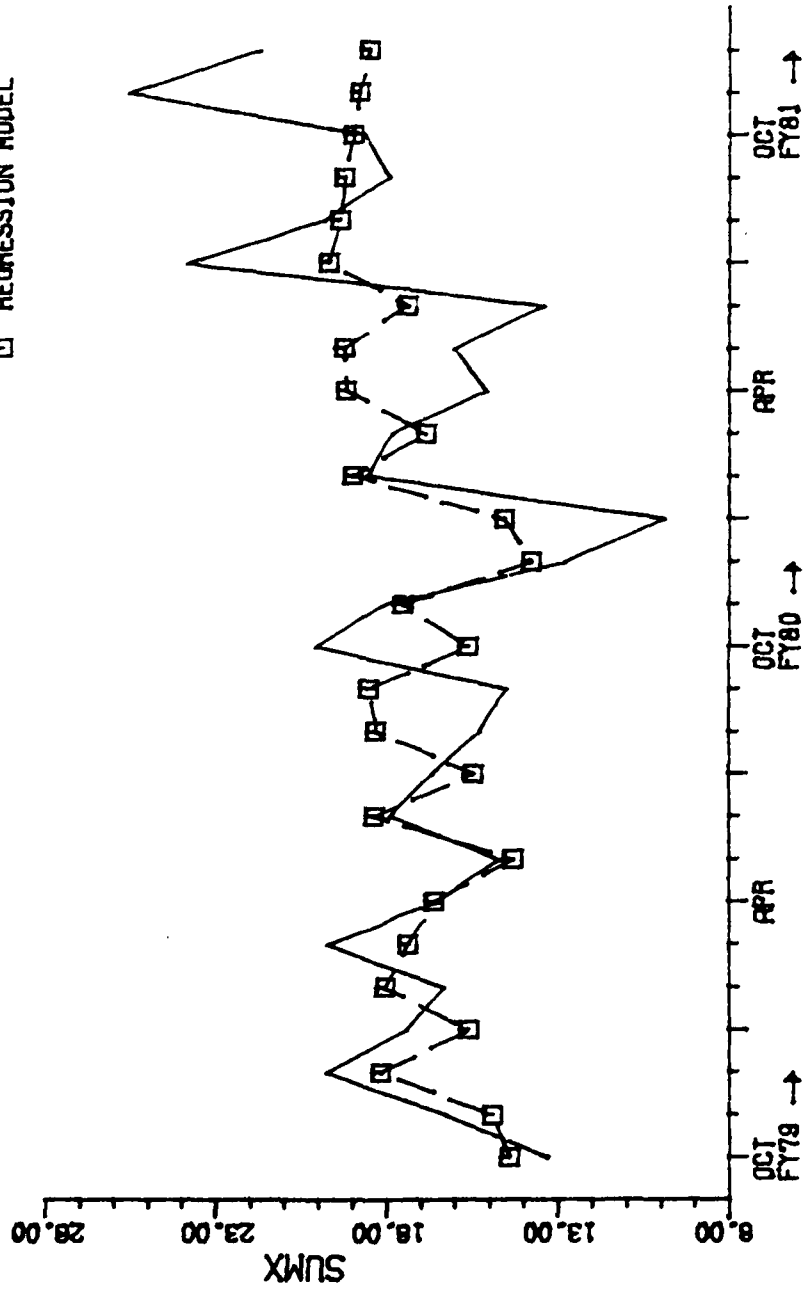

Fig 5. Actual and Predicted Values of SUMX - Moody AFB

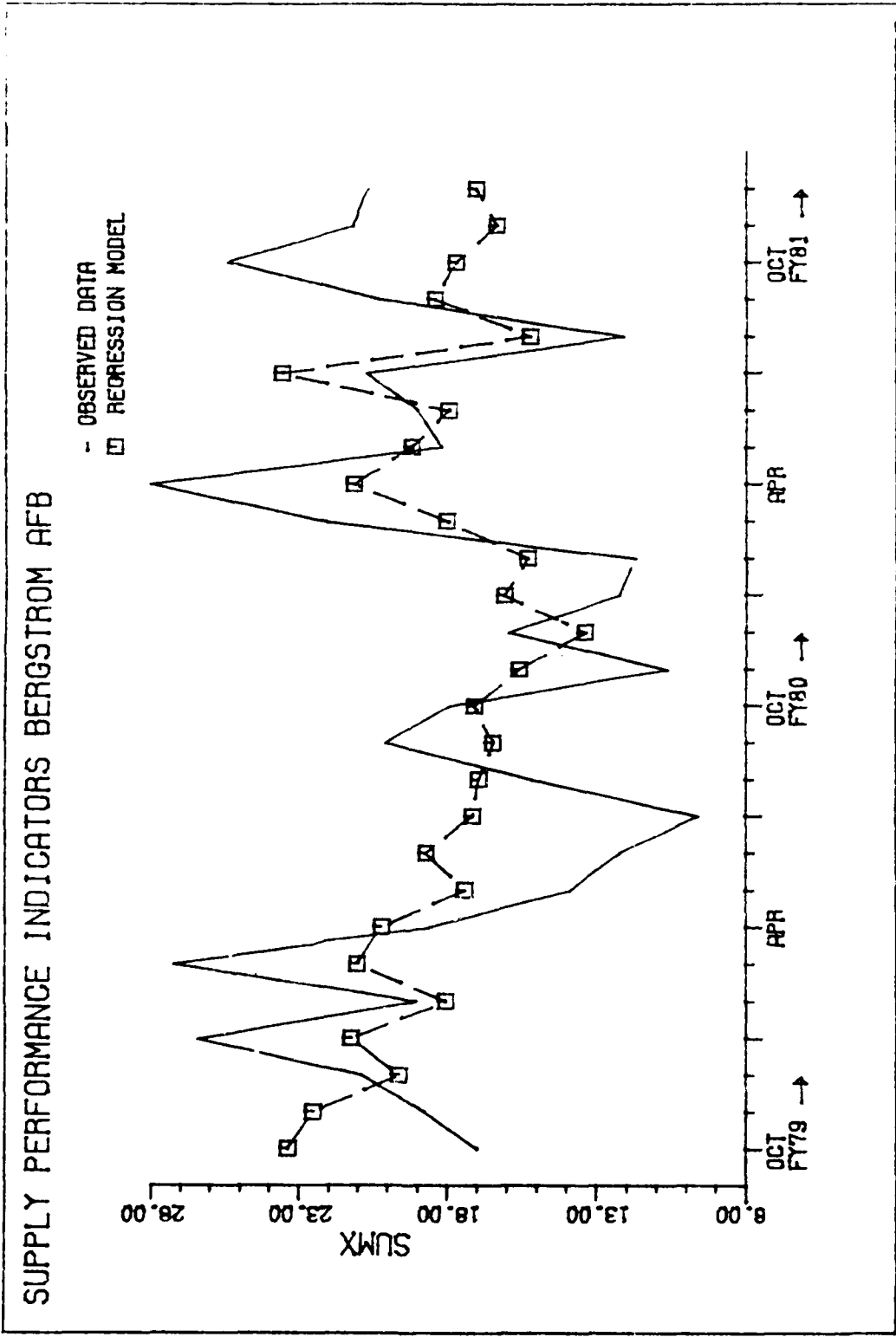

Fig 6. Actual and Predicted Values of SUMX - Bergstrom AFB

manner. The FY 79 and FY 80 models are shown along with the actual value of SUMX for both the Moody and Bergstrom data in Figures 7 and 8. The models are given below:

Moody AFB:

$$\text{FY 79: } \hat{\text{SUMX}} = 11.8 + .92 \text{ EOQB} + .368 \text{ EOQC} + .060 \text{ EOQD} + .113 \text{ REPC} - .078 * \text{REPD}$$

$$\text{FY 80: } \hat{\text{SUMX}} = 122.6 - .886 \text{ EOQNA} + 1.23 \text{ EOQC} - .236 \text{ REPGA} + .267 \text{ REPA} \\ - .253 * \text{REPB} - .0012 \text{ REPTII}$$

Bergstrom AFB:

$$\text{FY 79: } \hat{\text{SUMX}} = -133 + 1.66 * \text{EOQNA} + .052 \text{ EOQA}$$

$$\text{FY 80: } \hat{\text{SUMX}} = 42.2 - .077 * \text{EOQA} - .423 \text{ REPGA} + 541 \text{ REPA} + .280 \text{ REPB} \\ - 1.19 * \text{REPC} + .072 \text{ REPD}$$

One of the problems with these models is that one or more of the coefficients has a sign which appears counter-intuitive (coefficients with asterisks). For example, the Bergstrom FY 79 model indicates that an increase in the net availability of EOQ type items would result in an increase in the number of aircraft with degraded capability. However, these models are good fits to the actual value of SUMX in a given FY. The summary statistics for these regression models demonstrate this point.

<u>Model</u>	<u>Mean Square (Residuals)</u>	<u>R²</u>	<u>R²_A</u>	<u>F</u>
Moody FY 79	0.1214	.98	.97	68.24
Moody FY 80	2.6736	.90	.81	10.32
Bergstrom FY 79	18.4506	.45	.32	3.62
Bergstrom FY 80	2.6222	.96	.90	17.73

These models were selected using a forward selection technique with the critical partial F value set to 2.3, which is roughly equivalent to a level of significance $\alpha = 0.20$. Variables were added to the model as long as the

SUPPLY PERFORMANCE INDICATORS MOODY AFB

- OBSERVED DATA
 □ FY79 REGRESSION MODEL
 ◇ FY80 REGRESSION MODEL

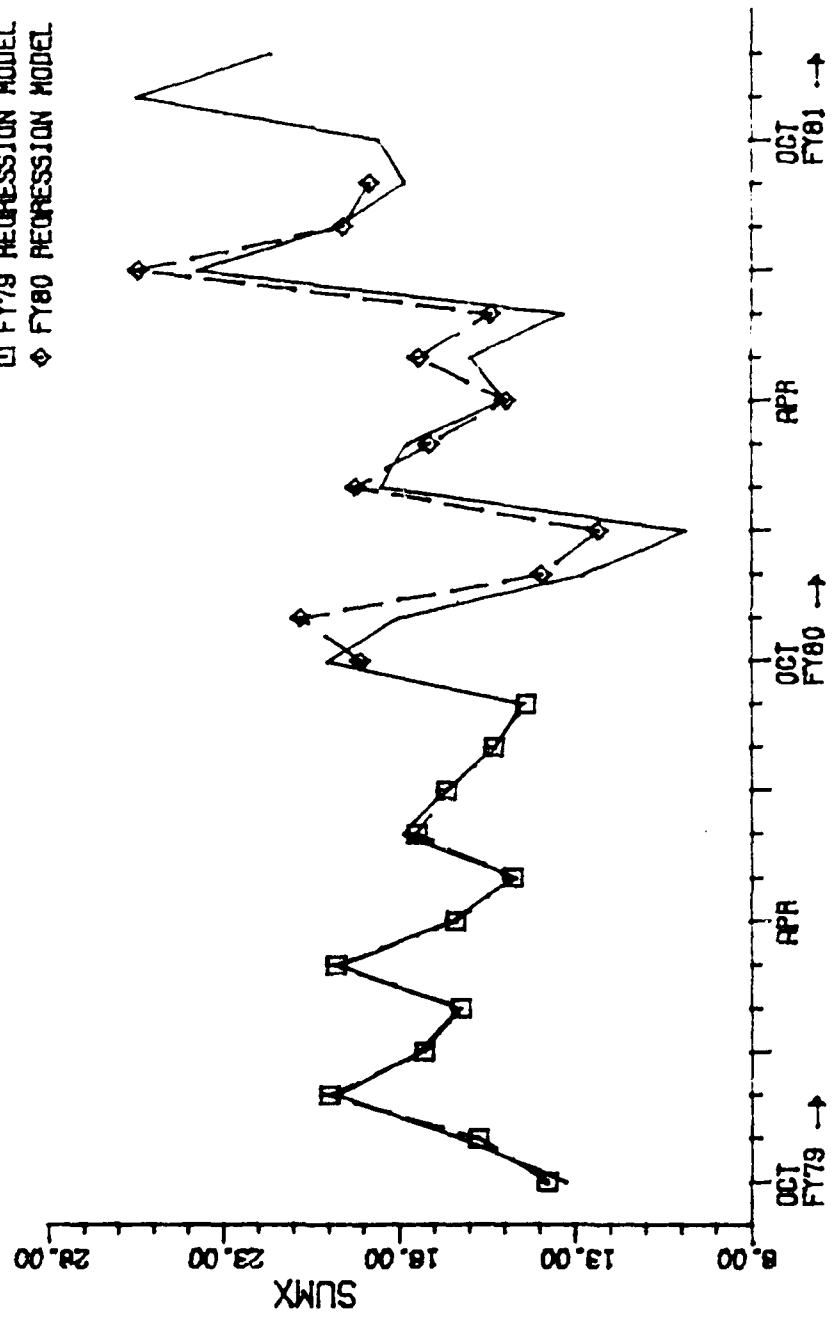

Fig 7. Actual and predicted values of SUMX using FY models - Moody AFB

SUPPLY PERFORMANCE INDICATORS BERGSTROM AFB

- OBSERVED DATA
 □ FY79 REGRESSION MODEL
 ◇ FY80 REGRESSION MODEL

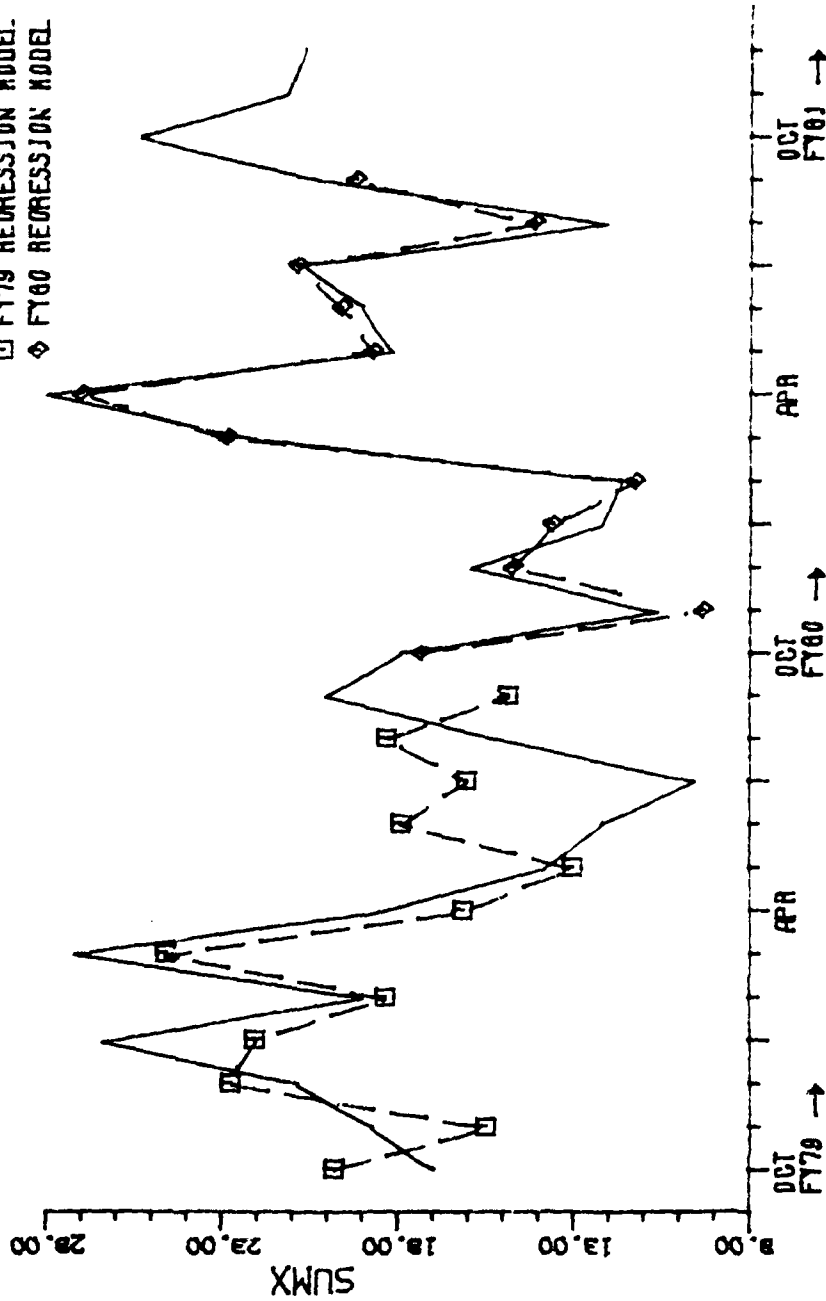

Fig 8. Actual and predicted values of SUMX using FY models - Bergstrom AFB

partial F exceeded 2.3 and as long as the adjusted R^2 value⁴, i.e., R_A^2 continued to increase. R_A^2 is a modification of R^2 that accounts for the number of variables in the model. The coefficient of multiple determination R^2 is defined as:

$$R^2 = 1 - \frac{SS_E}{SS_T}$$

where SS_E is the sum of squares due to residuals and SS_T is the total connected sum of squares.

In contrast R_A^2 takes into account the number of variables in the model since

$$R_A^2 = 1 - \frac{SS_E/(n-p)}{SS_T/(n-1)}$$

where p is the number of terms in the model and n is the number of observations. Unlike R^2 , R_A^2 may decrease as variables are added to the model.

The maximum number of variables permitted in the model was 6 since only 12 observations were used. This was purely judgmental; however, we felt that this was a reasonable limit.

As mentioned above, the predictive regression models change drastically from fiscal year to fiscal year. To determine if the change was gradual over time, or if the changes were just as drastic over small time intervals, additional regression models were developed for a moving twelve month window for the variables of interest, SUMX and NMCS. Twelve months were chosen to minimize the impact, if any, of seasonal variations, funding cycles, or operational requirements exercises. The data in Tables 2 and 3 show the wide variation in successive models when 10 of the 12 data points are identical. This lack of stability, together with the multitude of contradictory algebraic signs, leads to concern about domination of these dependent variables by factors outside the model. These factors may be as simple as different interpretations to the indicator definitions or as complex as major policy/command changes.

TABLE 2. Bergstrom AFB Regression Models ($\alpha = .10$)

<u>Data Period</u>	<u>Variables in SUMX Model</u>	<u>R²</u>
Oct 78 - Sep 79	EOQA	.28
Dec 78 - Nov 79	EOQNA**, REPGA	.50
Feb 79 - Jan 80	REPTII	.33
Apr 79 - Mar 80	EOQTII, REPC**	.54
Jun 79 - May 80	REPC**, REPTII	.62
Aug 79 - Jul 80	REPTII	.39
Oct 79 - Sep 80	REPGA, REPB	.64
Dec 79 - Nov 80	*	—
<u>Data Period</u>	<u>Variables in NMCS Model</u>	<u>R²</u>
Oct 78 - Sep 79	EOQNA**, REPGA	.60
Dec 78 - Nov 79	EOQNA**, REPGA	.60
Feb 79 - Jan 80	*	—
Apr 79 - Mar 80	*	—
Jun 79 - May 80	REPNA**, REPC**, REPTII	.77
Aug 79 - Jul 80	EOQTII**	.32
Oct 79 - Sep 80	EOQGA**, REPD**	.57
Dec 79 - Nov 80	EOQGA**, EOQTII**	.75

* Model could not be formulated at the $\alpha = .10$ significance level.

** Model has this variable with an intuitively contradictory algebraic sign.

TABLE 3. Moody AFB Regression Models ($\alpha = .10$)

<u>Data Period</u>	<u>Variables in SUMX Model</u>	<u>R²</u>
Oct 78 - Sep 79	EOQB, EOQC, EOQD, REPC, REPD**	.98
Dec 78 - Nov 79	EOQNA, EOQTII**	.52
Feb 79 - Jan 80	EOQGA**, EOQNA, REPA, REPTII**	.83
Apr 79 - Mar 80	*	—
Jun 79 - May 80	*	—
Aug 79 - Jul 80	REPGA, REPTII	.56
Oct 79 - Sep 80	REPA, REPB**, REPTII	.76
Dec 79 - Nov 80	REPGA	.44
<u>Data Period</u>	<u>Variables in NMCS Model</u>	<u>R²</u>
Oct 78 - Sep 79	REPA	.45
Dec 78 - Nov 79	*	—
Feb 79 - Jan 80	REPA	.32
Apr 79 - Mar 80	REPA	.32
Jun 79 - May 80	*	—
Aug 79 - Jul 80	REPA, REPTII	.67
Oct 79 - Sep 80	REPGA**, REPA, REPB**, REPTII	.88
Dec 79 - Nov 80	*	—

* Model could not be formulated at the $\alpha = .10$ significance level.

** Model has this variable with an intuitively contradictory algebraic sign.

These results serve only to demonstrate the difficulty of developing a robust predictive model. As a general rule, we observe that the due-out variables and the availability variables are useful indicators to predict operational capability levels. However, the dramatic change in the models makes forecasting questionable. In fact, the single exponential time series models do a better job of forecasting and these are recommended if forecasting is required.

An alternative to the time series models for forecasting would be to develop a weighted regression model (using perhaps exponential weighting) and then to forecast only one month in advance. 2Lt (then C1C) Michelle Johnson worked on this only briefly during a Math 499 course and her entire report is cited as reference [57]. Figure 9, which will serve to illustrate this technique and compare it with the time series forecast, is included here. We observe that although the weighted regression model forecast follows the actual observations more dramatically, it also misses rather dramatically on occasion such as for July and October 1980.

3. Search for the Best Causative Model

The second objective of this research, to determine supply performance goals that will achieve a stated level of operational capability, implies that we wish to determine cause-effect relationships between a performance indicator and a set of explanatory supply measures. Section 2 of the report clearly does not address this issue. Prediction and forecasting are discussed primarily because they represent work that was accomplished in pursuit of this second goal.

A causal relationship cannot be validated without additional experimental evidence. In this particular case, it is unlikely that one would ever be able to control the system in such a way as to obtain this information. Thus, when we state that we have a "causative model" we simply mean that we have a model

SUPPLY PERFORMANCE INDICATORS

BERGSTROM AFB

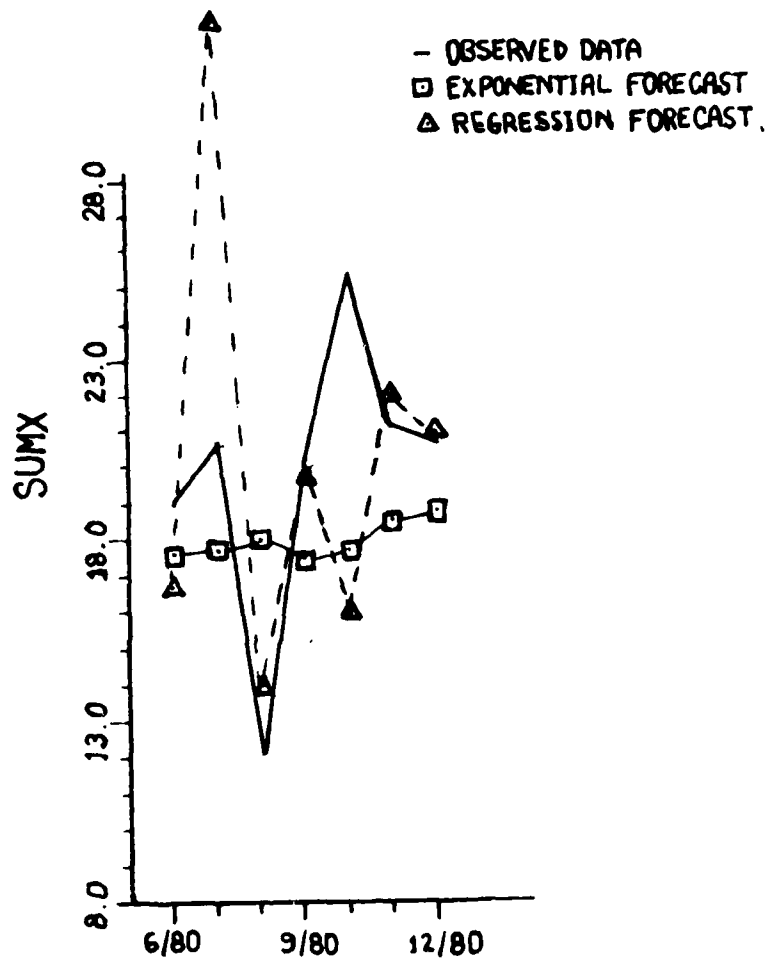

Fig 9. Forecasts for 6/80 - 12/80 Using Time Series and Weighted Regression Models - Bergstrom AFB

which has good face validity. That is, the relationships among the variables seem reasonable and have good intuitive appeal. There is no attempt to validate such a model using the observations provided since standard statistical techniques can address only significant correlations rather than cause-effect relationships.

Since the fiscal year models provided the best results in the previous section, we decided to look at the causative models by fiscal year as well. The procedure for developing these models was somewhat similar to the sequential selection procedure used in Section 2, except that the sign of the regression coefficient was examined for face validity. We postulated that measures of supply performance that should correlate negatively with degraded capability rates were the measures of availability of parts and the inventory investment (EOQGA, EOQNA, EOQTII, REPGA, REPNA, REPTII). The remaining measures, the number of monthly due-outs, were expected to have a positive correlation with the degraded capability. Thus, as availability or inventory investment increases, we would expect NMCS or SUMX to decrease, and as the number of due-outs increase, we expect NMCS or SUMX to increase also.

The following causative models were developed:

Moody AFB:

$$\begin{aligned} \text{FY 79: } \hat{\text{SUMX}} &= 56.28 + .0983 \text{ REPA} - .4984 \text{ EOQNA} \\ \hat{\text{NMCS}} &= 24.65 + .1392 \text{ REPA} - .2648 \text{ EOQNA} \\ \text{FY 80: } \hat{\text{SUMX}} &= 32.36 + .2606 \text{ REPA} - .001361 \text{ REPTII} \\ \hat{\text{NMCS}} &= 22.69 + .1581 \text{ REPA} - .001294 \text{ REPTII} \end{aligned}$$

Bergstrom AFB:

$$\begin{aligned} \text{FY 79: } \hat{\text{SUMX}} &= 2.387 + .0418 \text{ EOQA} + .2567 \text{ REPB} \\ \hat{\text{NMCS}} &= 37.95 - .5308 \text{ REPGA} + .1685 \text{ REPB} \\ \text{FY 80: } \hat{\text{SUMX}} &= 78.93 - .9465 \text{ REPGA} + .1715 \text{ REPB} \\ \hat{\text{NMCS}} &= 6.225 + .0746 \text{ REPB} \end{aligned}$$

These models are somewhat more satisfying than the previous models because of their consistency. The set of explanatory variables for Moody AFB always contain REPA and utilize EOQNA for FY 79 and REPTII for FY 80. The models for Bergstrom AFB always contain REPB and two of them use REPGA. With the exception of the Bergstrom FY 80 model for NMCS and the FY 79 model for SUMX, all models contain one measure of due-outs and one measure of availability/investment. The summary statistics for these models show, however, that they do not fit the data as well as the predictive models.

"CAUSATIVE" MODELS SUMMARY

<u>Model</u>	<u>Mean Square (Residuals)</u>	<u>R²</u>	<u>R_A²</u>	<u>F</u>
Moody FY 79 (SUMX)	2.51	.46	.34	3.89
Moody FY 79 (NMCS)	1.63	.54	.44	5.25
Moody FY 80 (SUMX)	6.47	.62	.54	7.39
Moody FY 80 (NMCS)	5.07	.56	.46	5.69
Bergstrom FY 79 (SUMX)	19.79	.41	.27	3.07
Bergstrom FY 79 (NMCS)	5.22	.58	.49	6.33
Bergstrom FY 80 (SUMX)	11.64	.64	.56	8.05
Bergstrom FY 80 (NMCS)	5.74	.25	.18	3.35

The above results show that the NMCS model is superior to the SUMX model (in terms of its ability to explain the variation in the data) for FY 79. However, the SUMX model is better for FY 80. We hesitate to strike too many conclusions from these data since we are dealing with relatively low R² values. The residual analysis for these models showed no evidence that transformations of the independent variables were called for. A comparison of the predicted regression values with the actual data is shown in Figures 10-13.

An examination of these plots indicates that the overall fits are somewhat better for Moody AFB. The primary difficulty with the Bergstrom models appears

SUPPLY PERFORMANCE INDICATORS MOODY AFB

- OBSERVED DATA
- FY79 REGRESSION MODEL
- ◇ FY80 REGRESSION MODEL

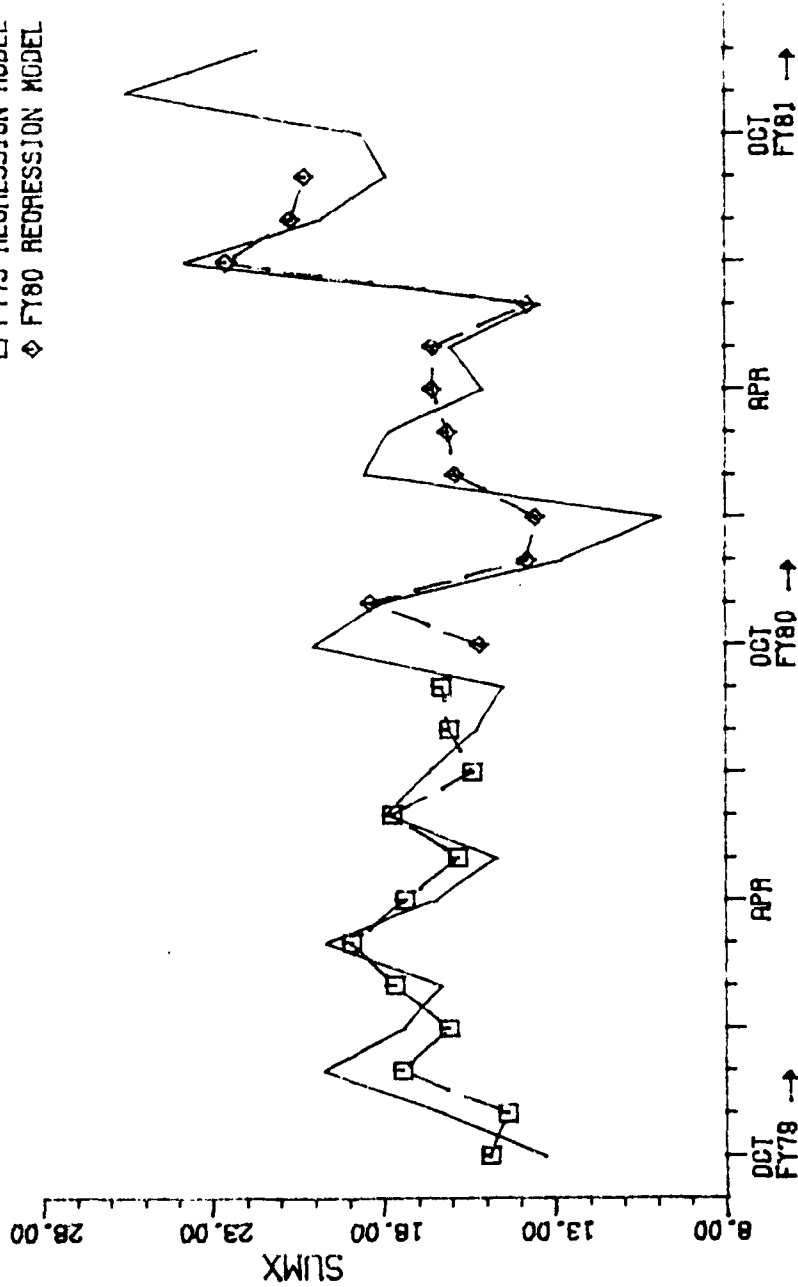

Fig 10. "Causative" Regression Models for SUMX by FY - Moody AFB

SUPPLY PERFORMANCE INDICATORS MOODY AFB

- OBSERVED DATA
 □ FY79 REGRESSION MODEL
 ◆ FY80 REGRESSION MODEL

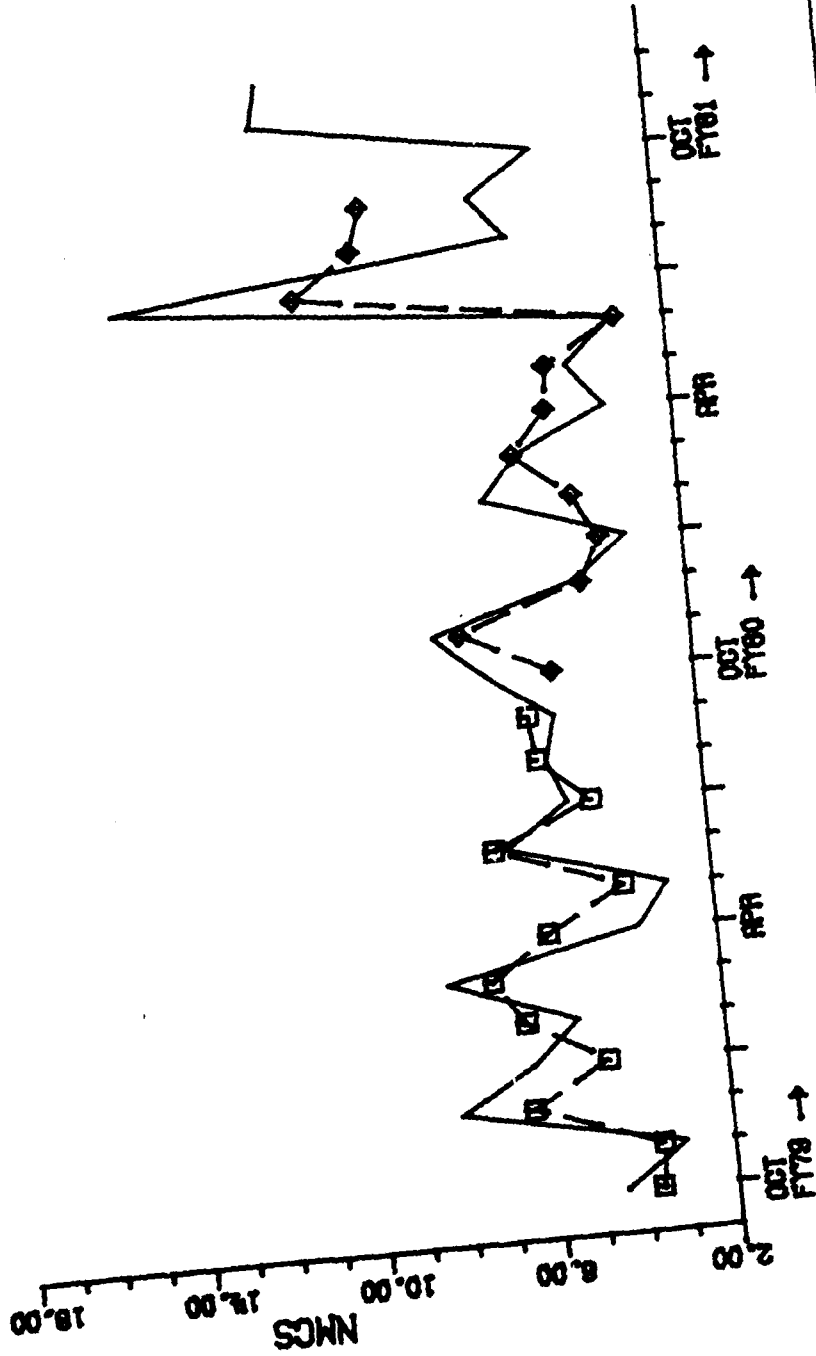

Fig 11. "Causative" Regression Models for NMCS by FY - Moody AFB

SUPPLY PERFORMANCE INDICATORS BERGSTROM AFB

- OBSERVED DATA
 □ FY78 REGRESSION MODEL
 ◇ FY76 REGRESSION MODEL

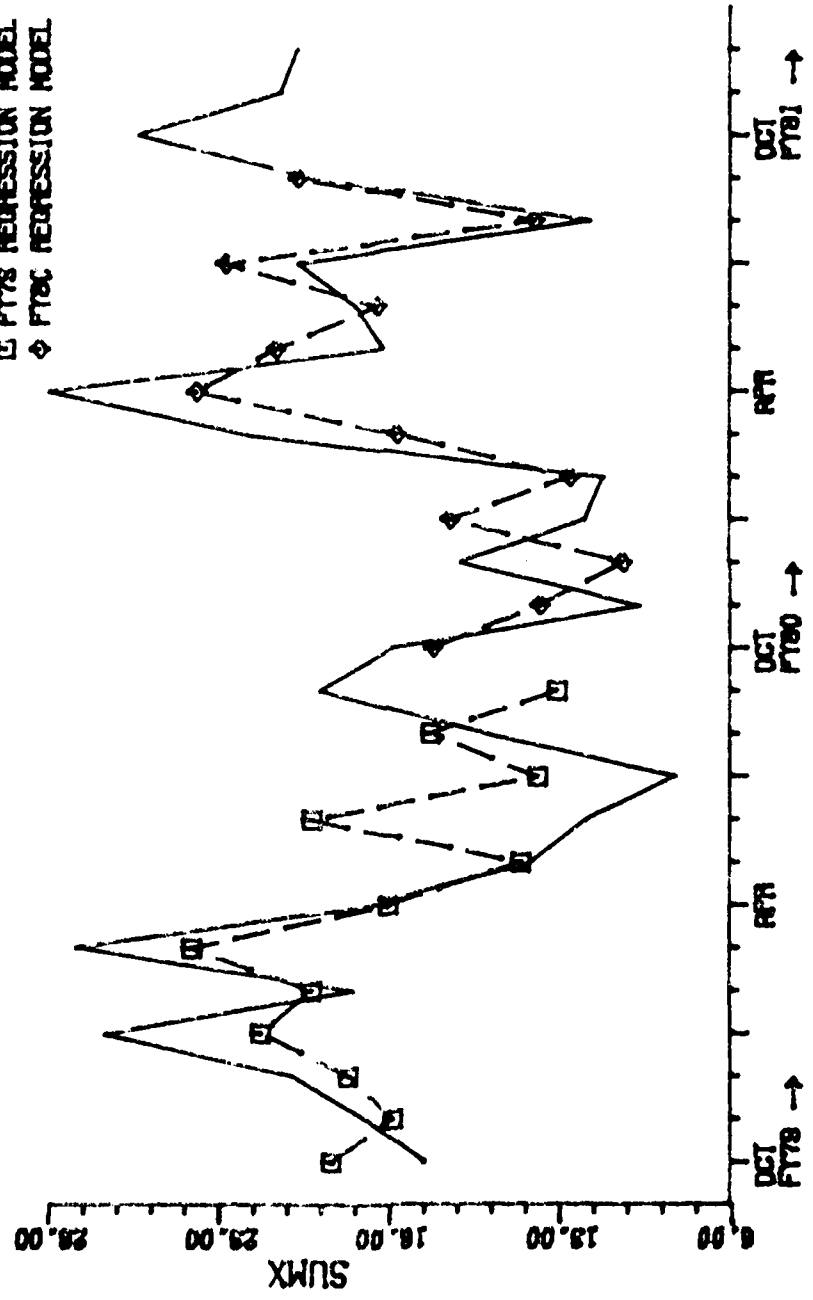

Fig 12. "Causative" Regression Models for SUMX by FY - Bergstrom AFB

SUPPLY PERFORMANCE INDICATORS BERGSTROM AFB

- OBSERVED DATA
- FY78 REGRESSION MODEL
- ◆ FY80 REGRESSION MODEL

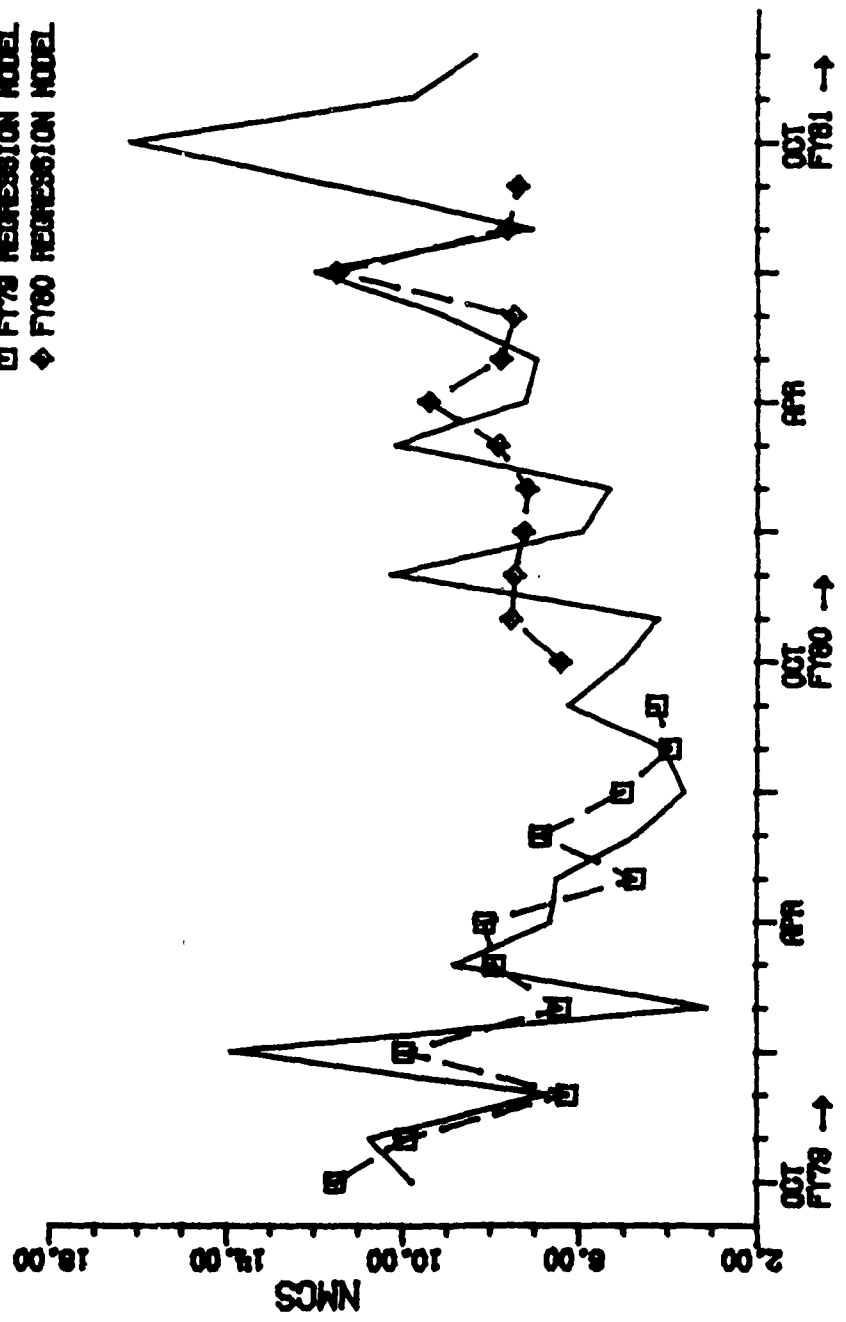

Fig 13. "Causative" Regression Models for NMCS by FY - Bergstrom AFB

to occur during the last half of calendar year 1980. It is interesting to note also that the data for Moody AFB during FY 79 and FY 80 exhibit no particular trend; while for Bergstrom AFB there is a general downward trend in the dependent variables for FY 79, but a contrasting upward trend for FY 80. This is more pronounced for NMCS (see Figure 13).

The "causative" models for the complete set of 27 observations were the same as the "predictive" models previously mentioned. For convenience, we repeat them here:

Moody AFB:

$$\hat{\text{SUMX}} = 20.08 + .1826 \text{ REPA} - .1063 \text{ REPGA}$$

Bergstrom AFB:

$$\hat{\text{SUMX}} = 49.93 + .1417 \text{ REPB} - .5150 \text{ REPGA}$$

Although a model for NMCS was obtained for Moody it was inferior to the SUMX model, and no significant regression was obtained for NMCS using the Bergstrom data. The R^2 values for the above overall models were 0.30 and 0.26 respectively, considerably lower than the specific fiscal year models.

These models are not very impressive in terms of their ability to explain the variation in operational capability levels. However, they do demonstrate that there is a consistent relationship between due-outs and availability measures and the operational capability measures of NMCS and SUMX as we would intuitively expect. As previously mentioned, there is no way to validate a cause-effect relationship, although there would seem to be one. Unfortunately, the cause-effect relationships are no doubt complex. One method of analyzing these relationships is known as causal path analysis⁶. [See also reference 2, pages 383-397.]

4. Causal Path Analysis

To attempt to find causal relationships between the supply performance

indicators and the measures of performance, we exercised the statistical package for the social sciences capability in a proposed model of causal relationships. Causal path analysis requires two major assumptions:

- 1) the causal relationships (perhaps weak) are known.
- 2) the variables in the analysis are causally closed.

Satisfying the first relationship, given the apparent random nature much of this data exhibits, is not entirely possible. Correlations exist among many of the performance indicator variables which serve to disguise causal relationships. The economic order quantity (EOQ) and reparable (REP) variables naturally divide the independent variables into two classes. Total inventory investment (EOQ or REP) seems to be an externally influenced variable that would have a direct effect on availability and due-outs. Availability and due-outs ought to affect a performance measure like SUMX. This type of analysis led to the postulation of the model presented in Figure 14, with the causal order specified by the arrows between boxes. The stand alone arrows indicate the sum of all other causes for the variable in the box. These sources are essentially random error if the chosen model is adequate. If the model is inaccurate, these sources are the dominant causes and the model is not causally closed. The P_{ij} represent the standardized regression coefficients, which are used for ease of interpretation. In Figure 14, a unit change in Y_1 should bring about a P_{21} change in Y_2 . A unit change of Y_1 will cause a $P_{31} + (P_{21})(P_{32})$ change in Y_3 , and so on.

Figures 15 through 20 display causal path analysis results for the basic model, which was somewhat arbitrarily chosen midway through this study based on the variable relationships understood at that time. Gross availability was chosen over net availability. Due-out reason B, out-of-stock because of policy or management decision, was chosen over the others. Many of the results from the regression studies are apparent in these figures. These include

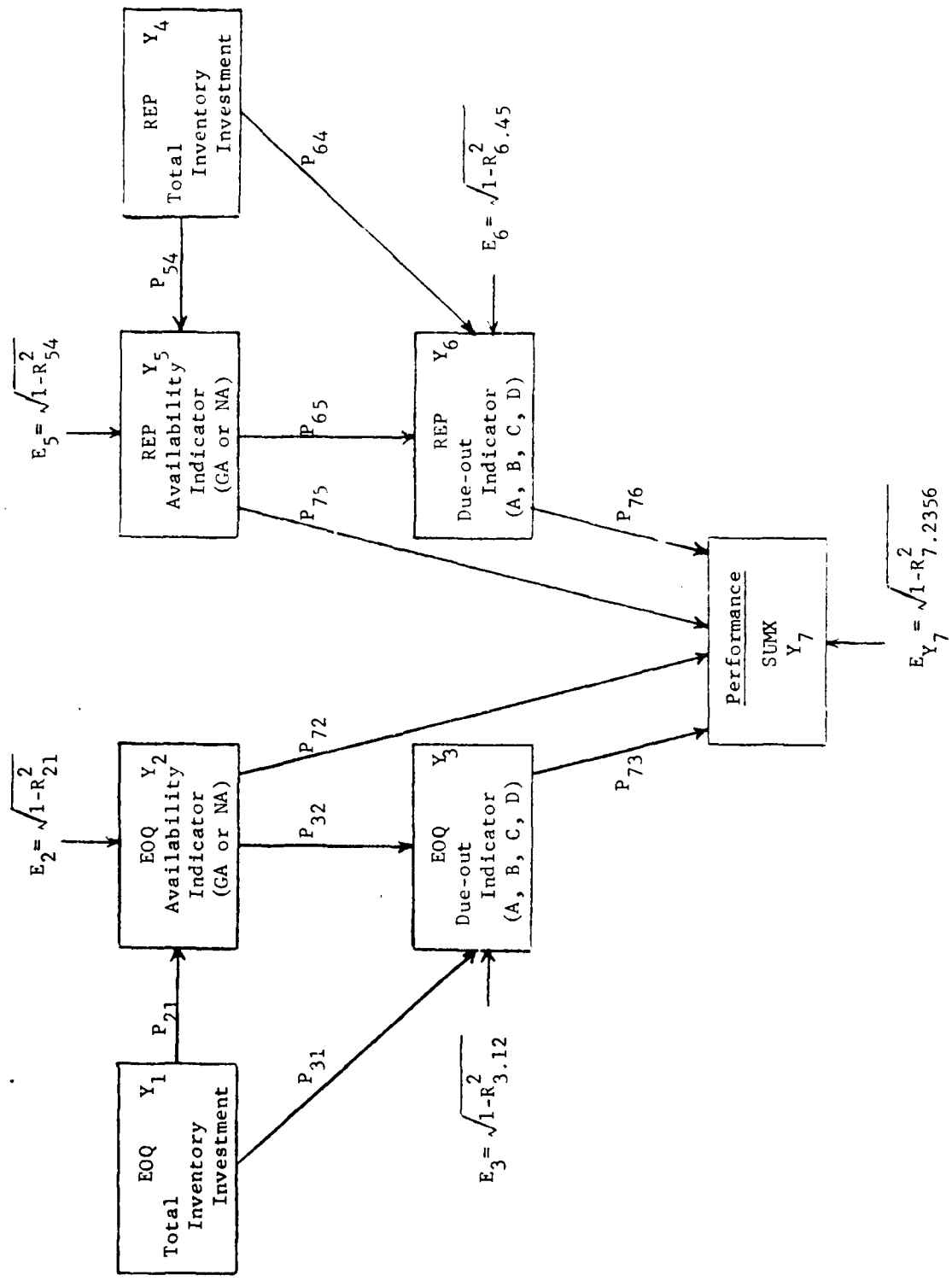

Figure 14. Causal Path Analysis - Hypothesized Model

Bergstrom AFB
FY 79

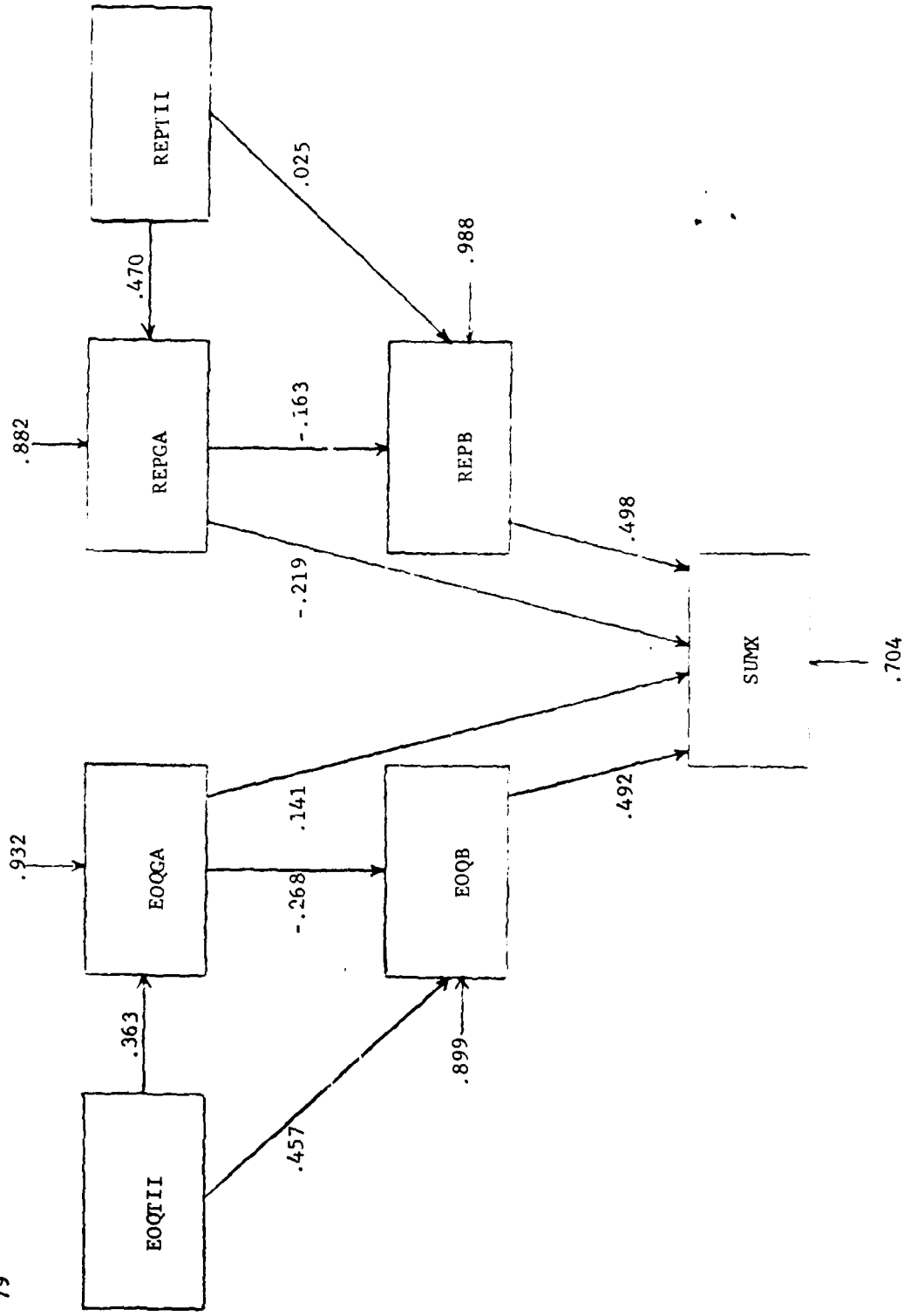

Figure 15. Causal Path Basic Model -
Bergstrom AFB, FY 79

Bergstrom AFB
FY 80

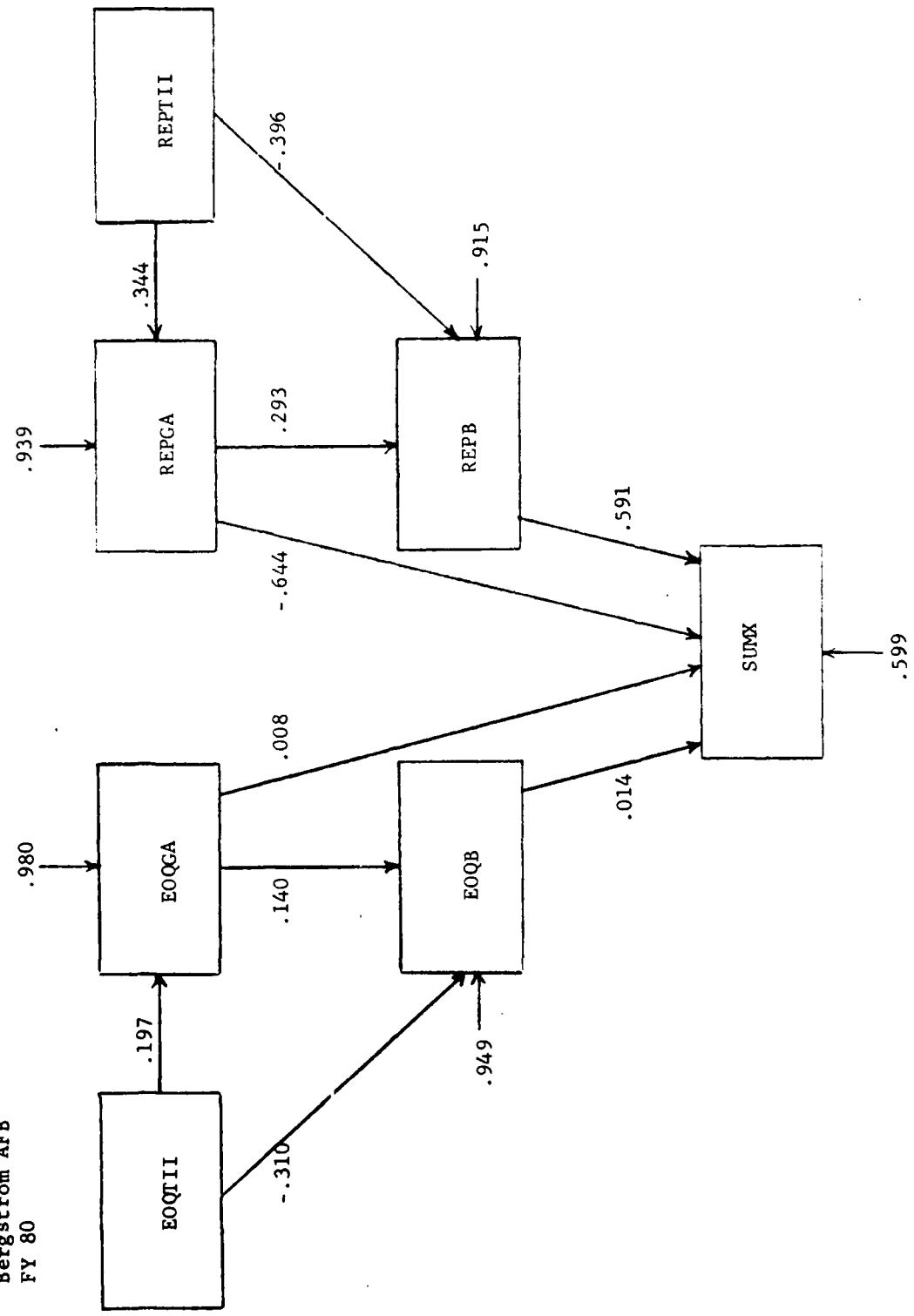

Figure 16. Causal Path Basic Model -
Bergstrom AFB, FY 80

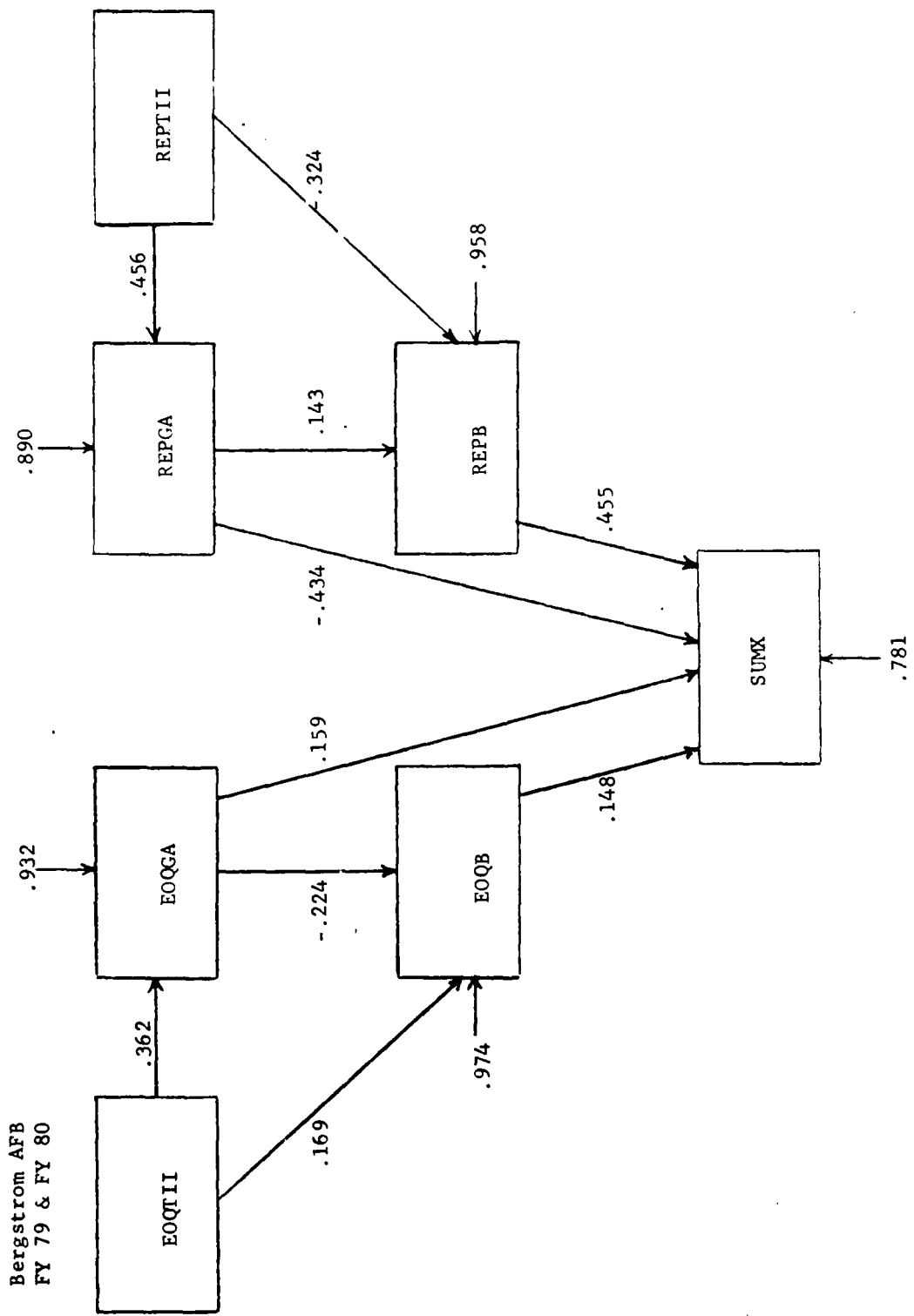

Figure 17. Causal Path Basic Model -
Bergstrom AFB, FY 79 & FY 80

Moody AFB
FY 79

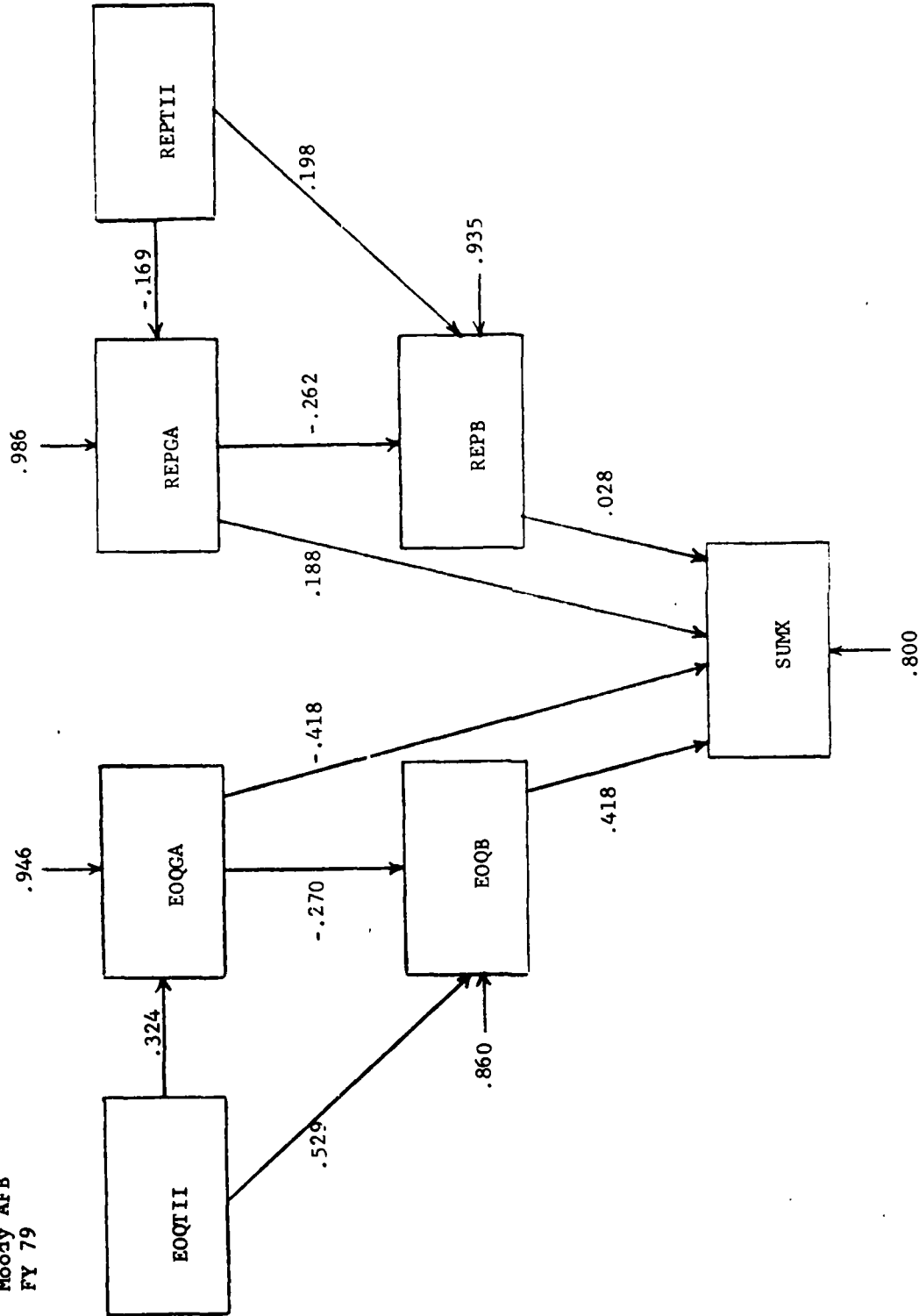

Figure 18. Causal Path Basic Model -
Moody AFB, FY 79

Moody AFB
FY 80

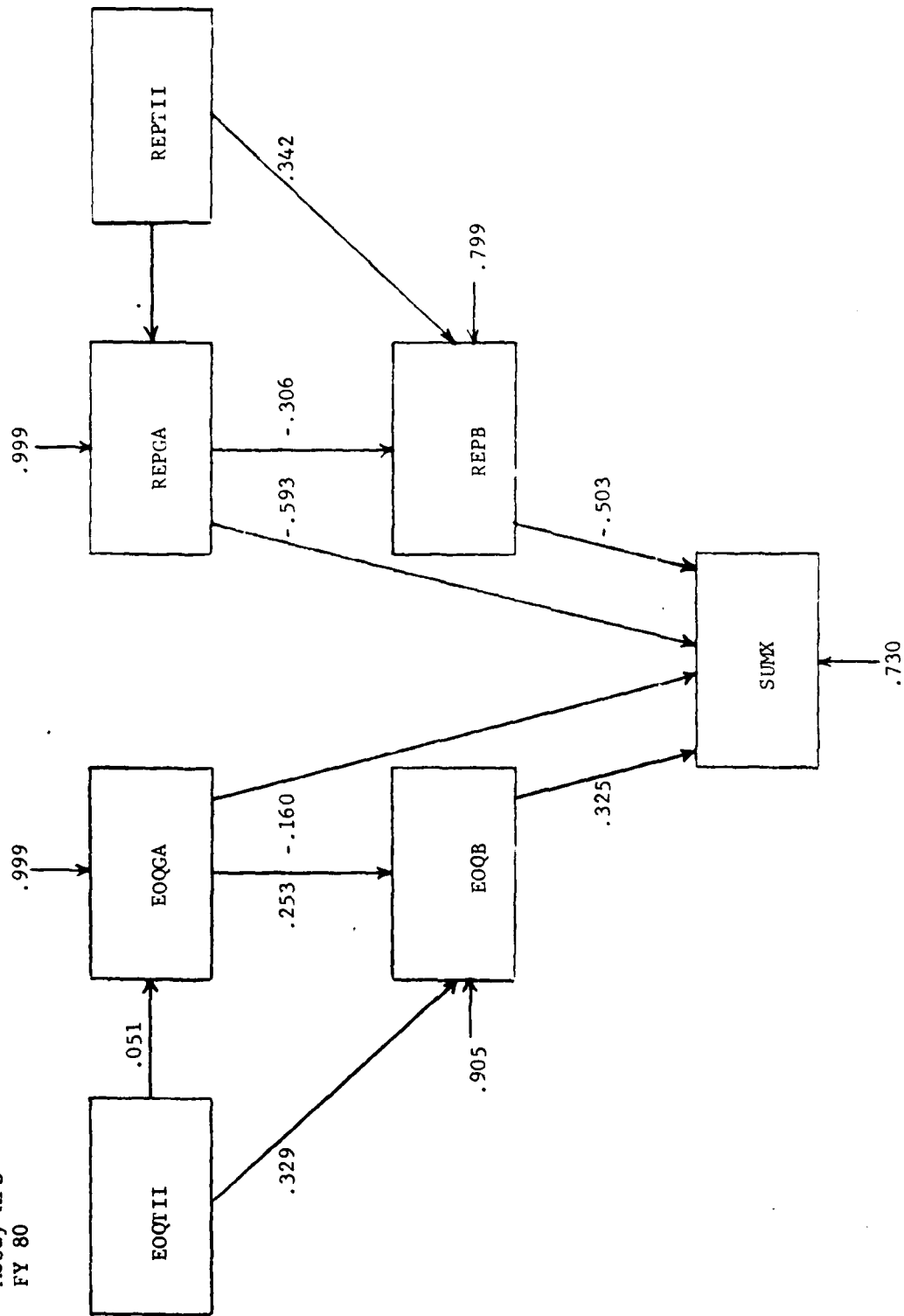

Figure 19. Causal Path Basic Model,
Moody AFB, FY 80

Moody AFB
FY 79 & FY 80

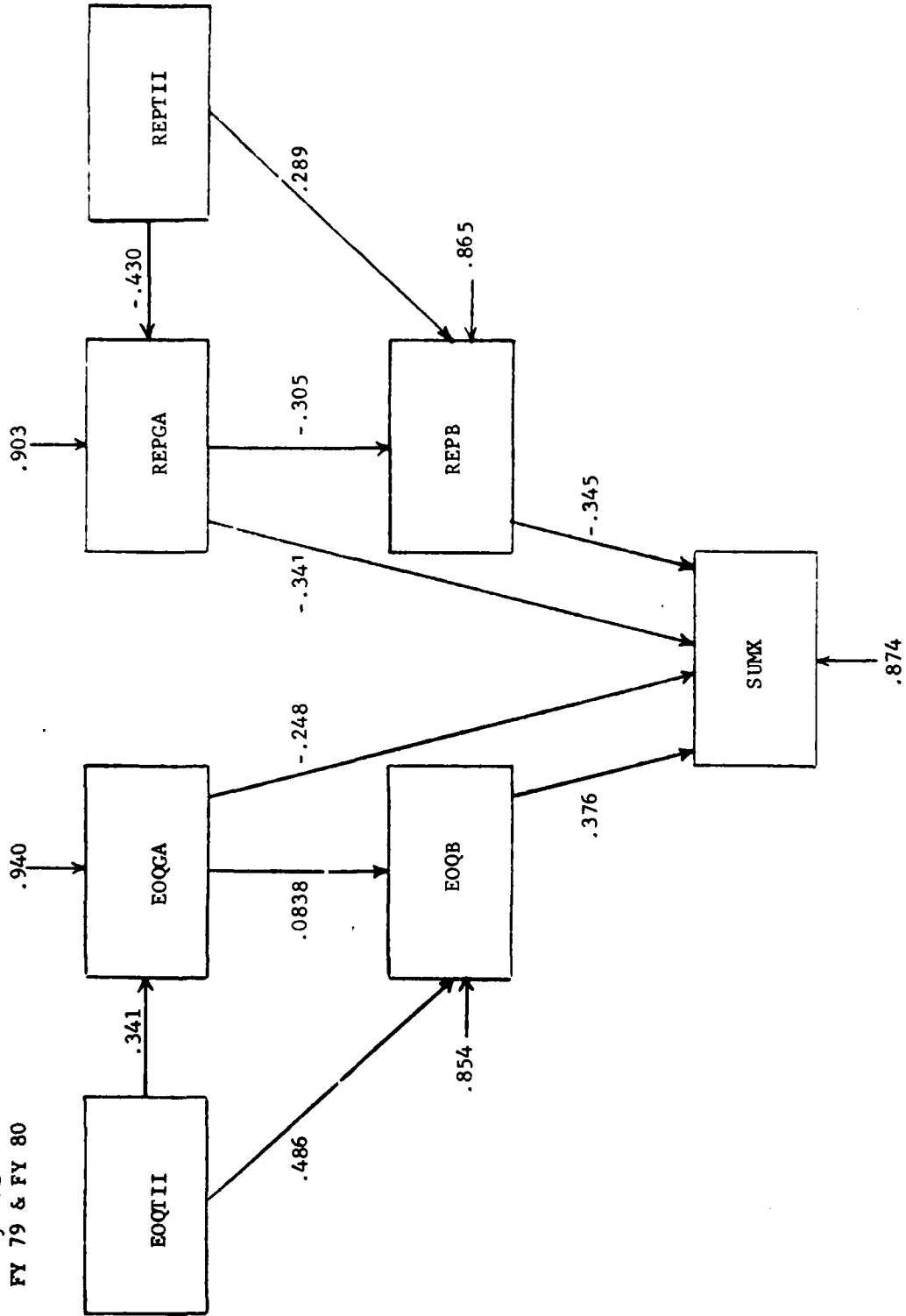

Figure 20. Causal Path Basic Model -
Moody AFB, FY 79 & FY 80

1) The error quantities are too large, indicating that there are perhaps other quantities causing the trends we're seeing.

2) The data is not stable from one period to another. There isn't consistency from FY 79 to FY 80. Combining the 24 data points doesn't provide any uniform improvement.

3) Standardized regression coefficients leave intuitively intolerable algebraic signs. In Figure 15, why should an increase in EOQGA (desirable) "cause" an increase (.141) in SUMX (a measure of degraded capability and undesirable)?

To try to improve on the basic model, we examined the correlation matrices for the two bases and two fiscal years to look for better variable choices, but still within the framework of the basic model. For EOQ and REP, either gross availability or net availability was chosen based upon the correlations within the model, i.e., with TII and SUMX. A similar estimate of the best variable was chosen for the due-outs (reasons A, B, C, and D). The results for these models are shown in Figures 21 through 24.

The additional effort in attempting to find stronger causal relationships did not produce a uniform improvement. Most of the criticism of the basic models can be applied to these selected models.

The entire effort at causal path analysis should be viewed as one providing additional insight into the data, but not as one that found strong, causal relationships. The concerns and conclusions from the predictive regression models also apply in the search for causal path models.

Although we could have continued to search for causal path models that would exhibit more desirable path coefficients, we felt that it would not add substantially to our understanding to continue. An example of how we might interpret one of the models is as follows for Figure 23 - the FY 79 Moody AFB model. We might argue that the paths between EOQTII and EOQD and REPTII and

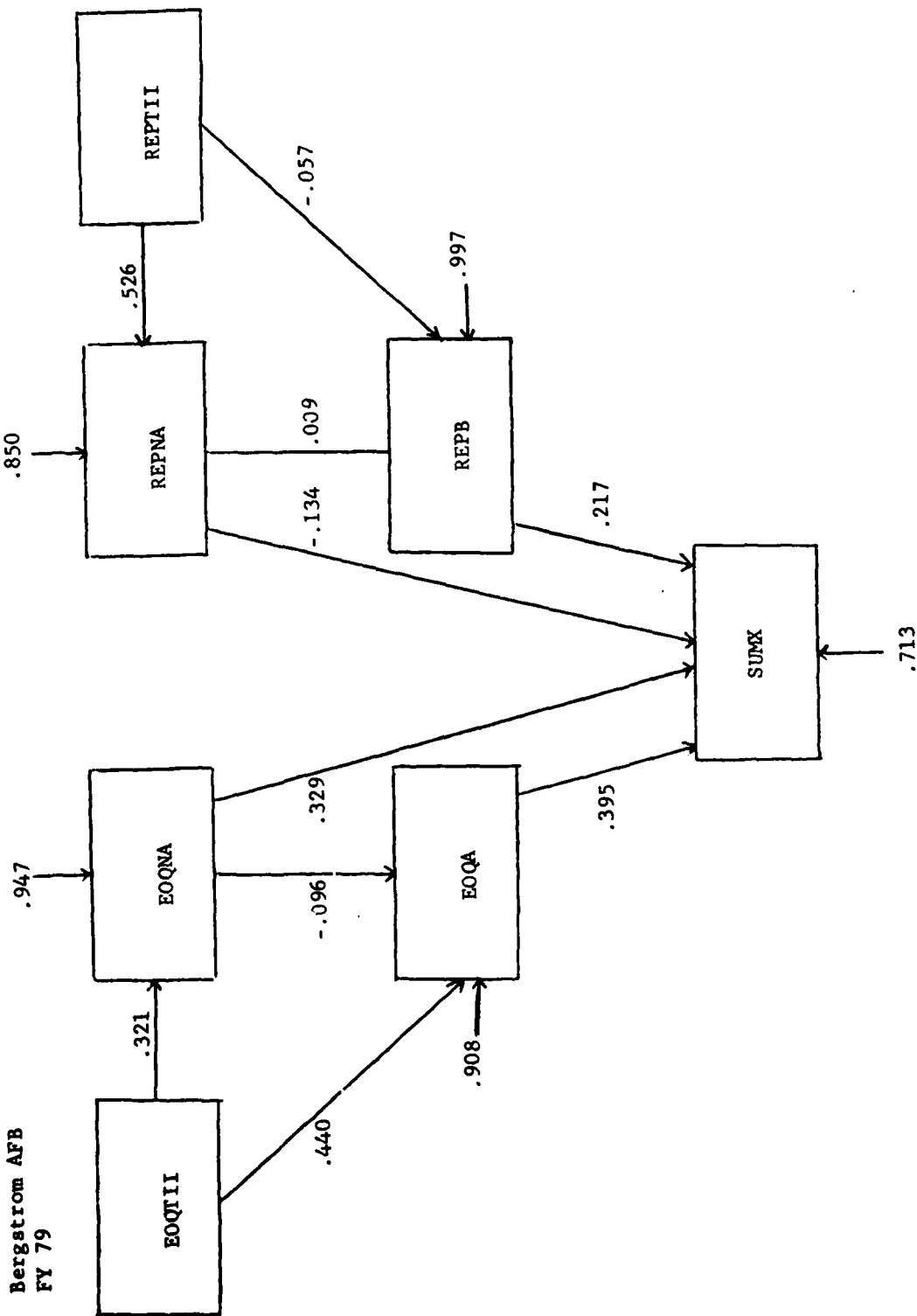

Figure 21. Causal Path, Selected Model -
Bergstrom AFB, FY 79

Bergstrom AFB
FY 80

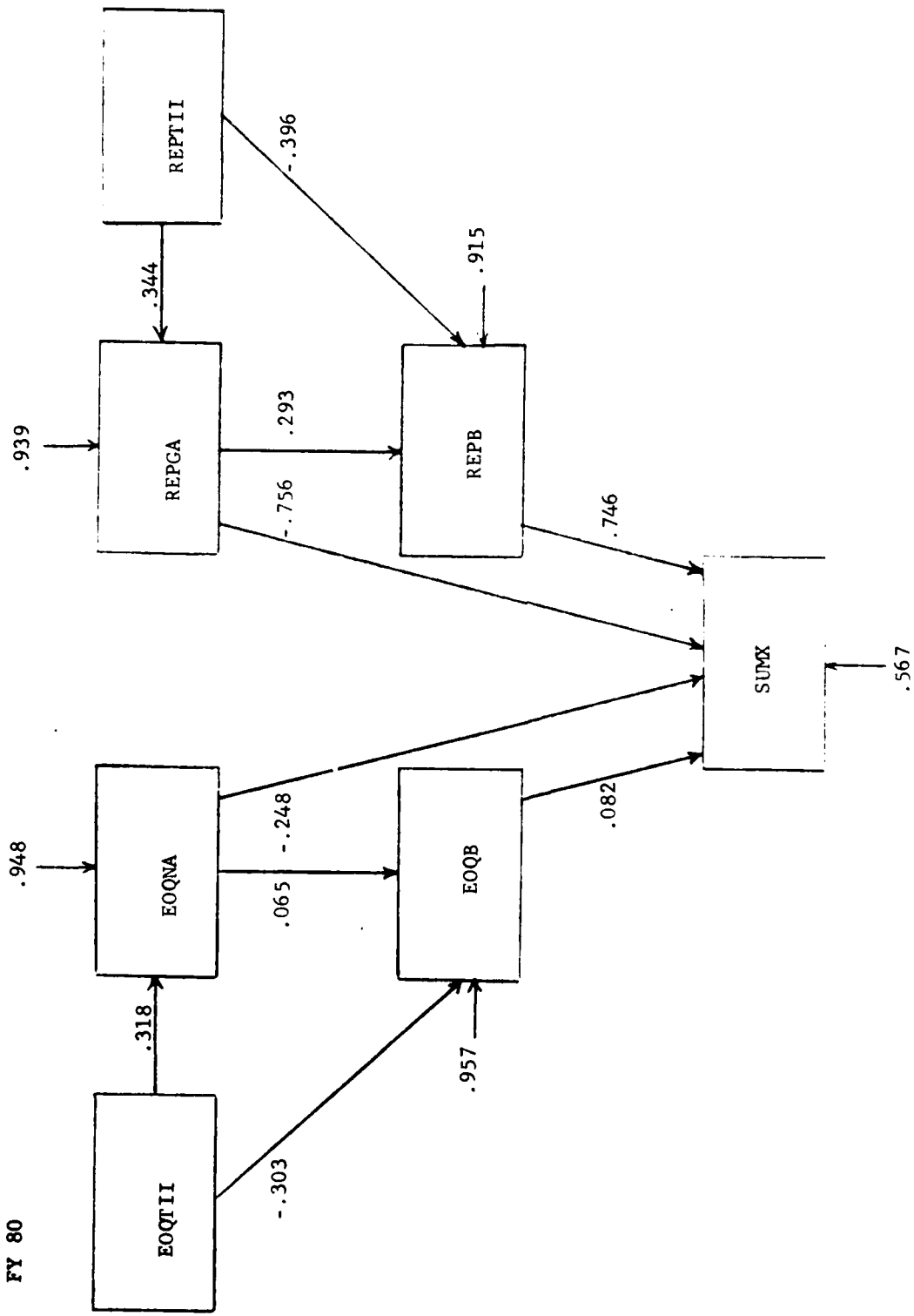

Figure 22. Causal Path Selected Model -
Bergstrom AFB, FY 80

Moody AFB
FY 79

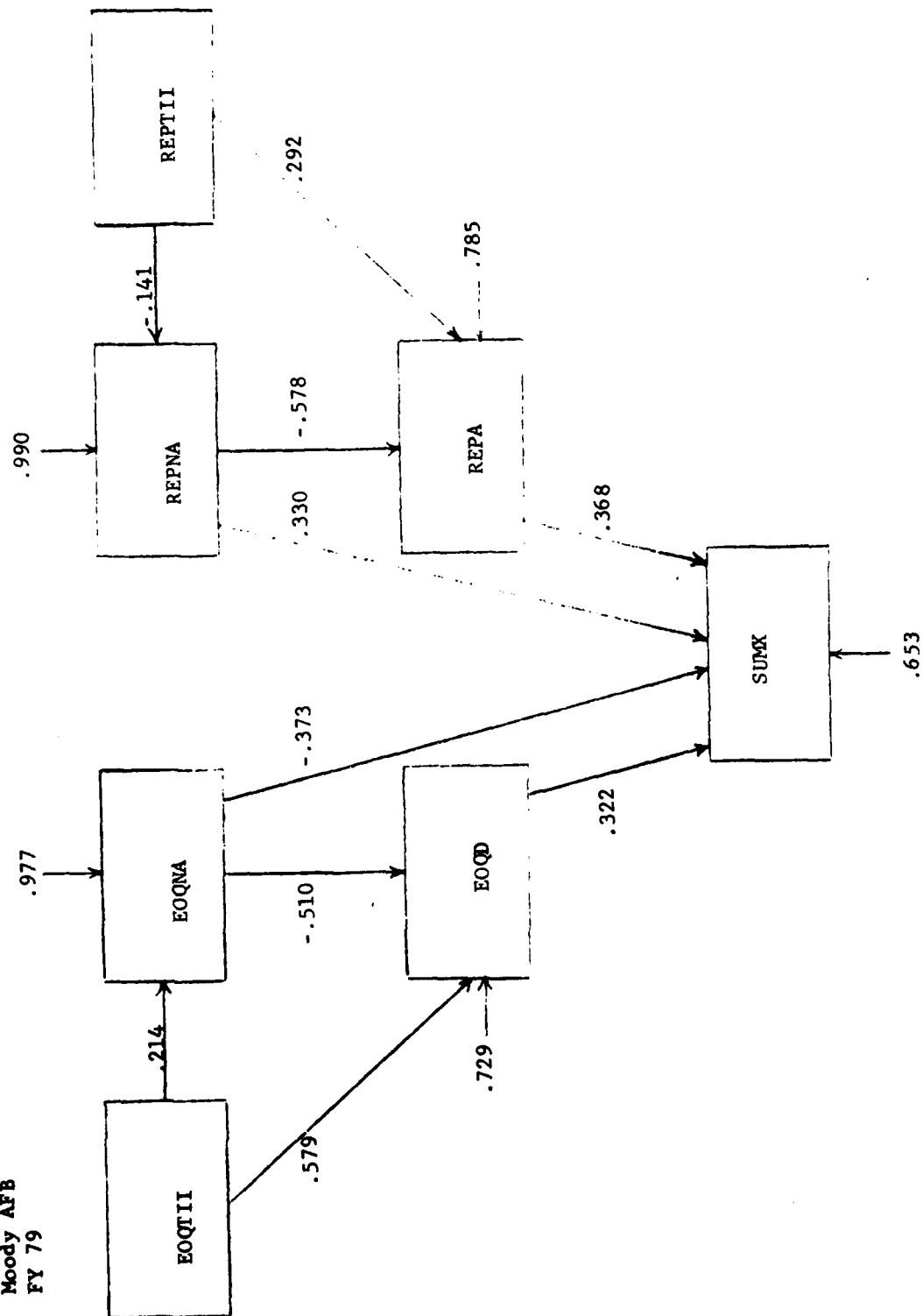

Figure 23. Causal Path Selected Model -
Moody AFB, FY 79

Moody AFB
FY 80

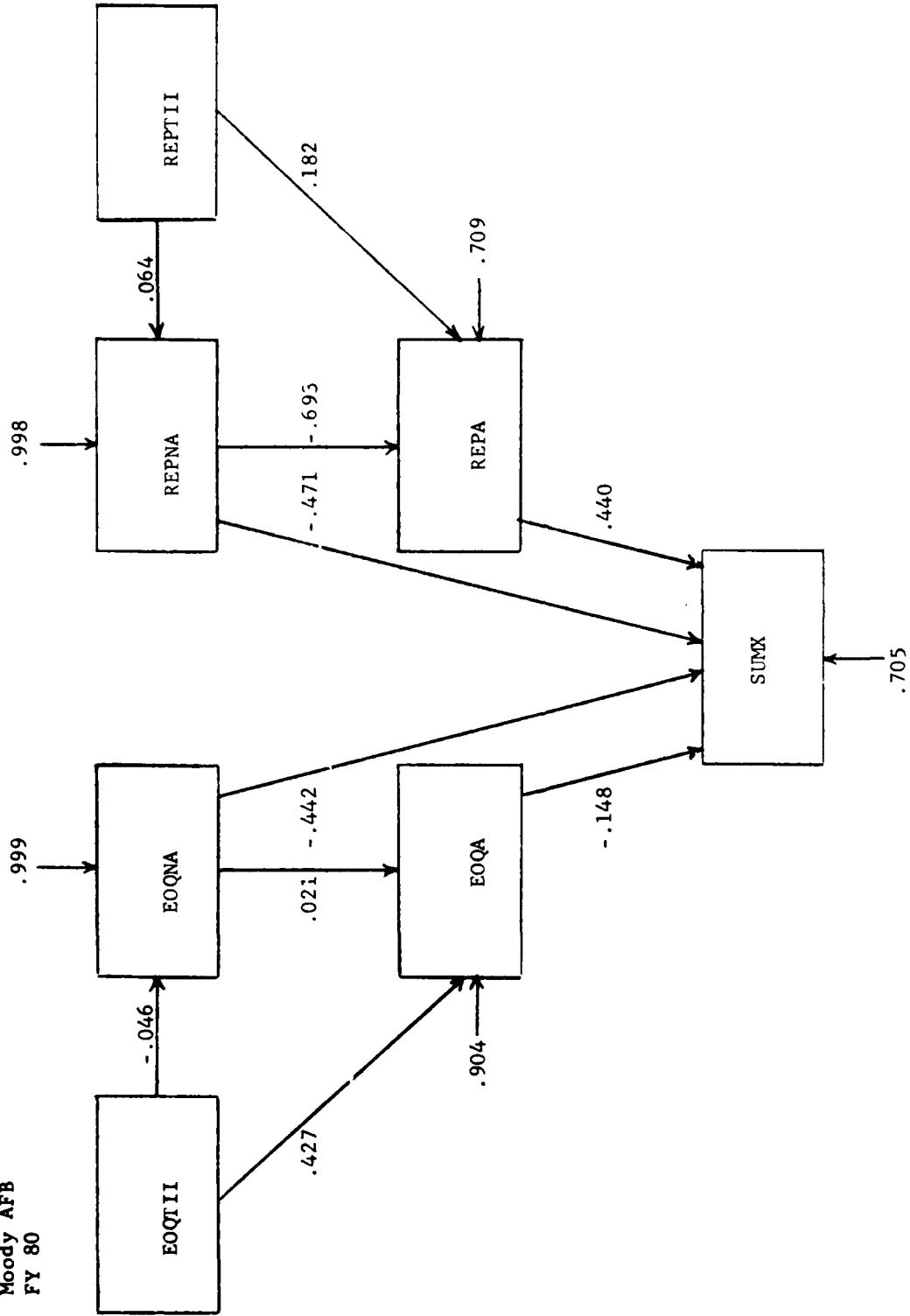

Figure 24. Causal Path Selected Model -
Moody AFB, FY 80

REPA should be eliminated as there may be no direct relationship there. This would take care of the apparent incorrect path sign. The fact that there are incorrect signs between REPTII and REPNA and REPNA and SUMX may be due to our inability to statistically determine a correct model due to large error sources in REPNA. The other signs appear correct. Finally, we note that over 65% of the variation in SUMX still must be attributed to other sources.

5. Summary and Conclusions

The original objective, to find statistically significant correlations between operational capability levels and supply performance measures, was addressed by developing predictive and causative regression models. Although not specifically requested, we also discussed the use of time series models for forecasting and compared these with the regression models. Since the secondary objective involved setting supply performance level goals in order to achieve stated levels of operational performance, we looked for cause-effect relationships using causal path analysis. There was no statistical way to verify any of these cause-effect relationships, but we did apply intuition and common sense in order to achieve models that had good face validity.

Due-out measures as well as availability measures clearly influence the operational capability levels. Unfortunately, the interrelationships among these various measures and the large source of error (i.e. unmeasurable factors that influence the operational capability levels) made it impossible to develop a robust model, even for a particular AFB.

Two measures of operational capability were discussed in this report: NMCS, the non-mission capable rate due to only supply reasons and SUMX (NMCS + PMCS + NMCB + PMCB), the mission-capability degraded rate due to supply reasons. We were able to generally develop better models for SUMX. This may perhaps be attributable to the fact that SUMX as the sum of the four given operational indicators may represent an averaging of the different

sources and cancel out any effects due to improper or inconsistent identification.

Although a general-purpose model could not be developed, the following results demonstrated some consistency among the models. For the fiscal year causative models, REPA always appeared as the due-out variable of interest in the Moody models. Similarly, REPB always appeared as the primary due-out variable in the Bergstrom models. Furthermore, six out of eight of these models included an availability or investment measure as well as the due-out measure. No model had more than two supply measure variables. The R^2 values for these models ranged from .25 to .64.

An overall model for SUMX for each base was developed. These models both used REPGA as the availability measure and either REPA or REPB as the due-out measure. We were surprised at the overall dominance of the reparable variables in these models. However, we hesitate to draw any specific conclusion from this without a deeper understanding of these measures. The term causative was used only to refer to the fact that the model had good face validity and to contrast it from the purely predictive models that were also addressed. In general, a causative model tended to have one due-out measure and one availability measure in it.

The predictive models fit the data much better, but offered little or no interpretive value and all had poor face validity. They were generally characterized by more variables (usually 5) and had much higher R^2 values ranging from .45 to .98.

A causal path analysis was discussed only for the purpose of helping to understand the possible cause-effect relationships which may exist among the variables. No validation was offered for this and it should only be viewed as a descriptive tool that may lend some insight into such relationships.

We were unable to achieve the second objective of this work which was to specify specific levels of supply measures which should be met. Such a result would require a robust cause/effect model. It is doubtful that this result could ever be achieved with the data that was provided for this study.

Finally, two areas of analysis that were investigated but proved unfruitful include lagging and advancing (in time) several of the independent variables, and averaging the monthly data by fiscal quarters in order to remove seasonality effects. These techniques provided models that were clearly worse than the ones discussed in this report.

6. Recommendations for Further Study

We feel that there is not much more that can be investigated with the present data set with the possible exception of developing weighted regression models. Some type of weighting (perhaps exponential) of the observations may provide the means to come up with a robust model with improved R^2 values and would be an attractive alternative to the specific fiscal year models developed.

If more data becomes available (at least two more fiscal years) a further investigation of the nature of the changes in the specific fiscal year models may provide some additional insight into these issues.

Insight into managerial policies that may change from one fiscal year to another might also provide an additional source of information with which to explain the change in fiscal year models. If such information were available further work on regression models may prove useful.

APPENDIX

	<u>Page</u>
List of Raw Data (Mcody AFB)	46
List of Raw Data (Bergstrom AFB)	47
Data Coding and Format	48
Time Series Models for NMCS	49

Data Coding and Format

Each data observation contains two records with the following information:

Record 1: Month, year, variable type, EOQGA, EOQNA, EOQA, EOQB, EOQC, EOQD,
EOQTII

Record 2: Base, variable type, REPGA, REPNA, REPA, REPB, REPC, REPD, REPTII,
NMCS, NMCB, PMCS, PMCB

The data is formatted for SPSS as follows:

FIXED (1X, 2F2.0, 4X, 2F6.2, 2F4.0, F3.0, F4.0, F8.1/
9X, 2F6.2, 2F4.0, F3.0, F4.0, F8.1, 4F6.2)

Time Series Models for NMCS

- a. Single Exponential Smoothing:

$$\widehat{\text{NMCS}}_{t+1} = 0.1 \text{NMCS}_t + 0.9 \widehat{\text{NMCS}}_t$$

Mean Square Error (MSE): 7.9

Mean Absolute Percentage Error (MAPE): 31.0%

- b. The best moving average model for NMCS was a 5-term moving average with:

MSE: 8.0

MAPE: 32.9%

REFERENCES

1. Maghsoodloo, S. and J. N. Hool, "Identify Measures of Supply Performance That Have a Statistically Significant Correlation With Measures of Operational Capability", final report, Industrial Engineering Dept, Auburn University.
2. Nie, Hall, Jenkins, Steinbrenner, and Bent, Statistical Package for the Social Sciences, 2nd Ed., McGraw Hill, 1975.
3. Makridakis, S. and S. Wheelwright, Interactive Forecasting, Scientific Press, 1974.
4. Hines, W. W. and D. C. Montgomery, Probability and Statistics in Engineering and Management Science, 2nd Ed., John Wiley, 1980.
5. Johnson, M. D., "Modeling Aircraft Mission Capable Status", Math 499 Final Report, USAF Academy, May 1981.
6. Blalock, H. M., Causal Models in the Social Sciences, Aldine, 1970.

**DA
FILM**