

AD-A105 611

NAVY EXPERIMENTAL DIVING UNIT PANAMA CITY FL
MARKET SURVEY AND ANALYSIS OF COMMERCIALY AVAILABLE FLOWMETERS--ETC(U)
AUG 81 E RANDALL

F/G 6/11

UNCLASSIFIED

NEDU-6-81

NL

1 OF 1
AD A
105611

2

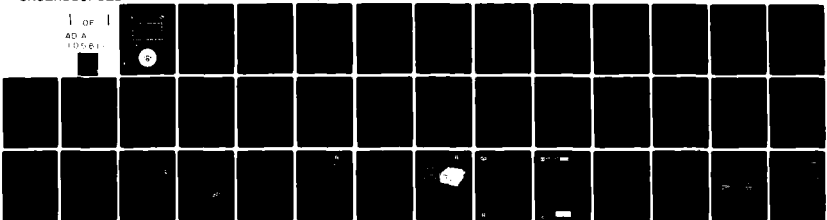

END
DUE
FILMED
11-81
DTIC



LEVEL II

6



AD A 1 0 5 0 1 1

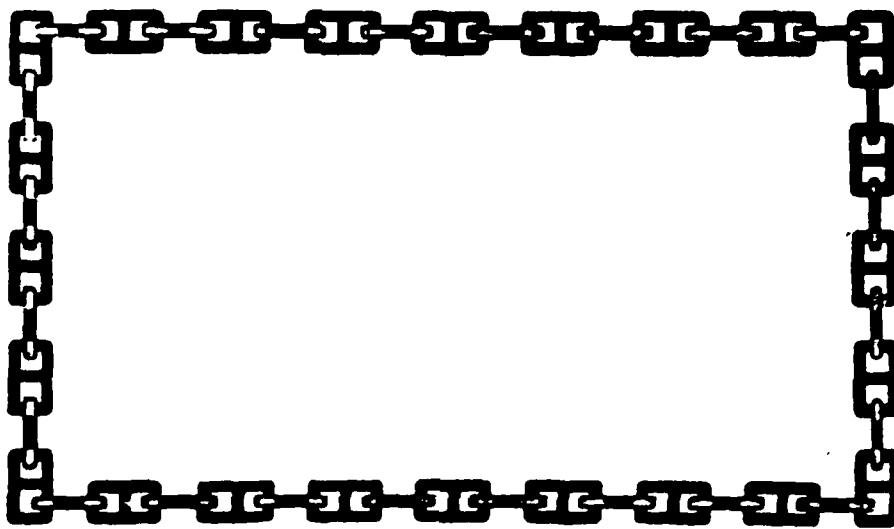

NAVY EXPERIMENTAL DIVING UNIT



DTIC
SELECTE
OCT 07 1981
S E

DTIC FILE COPY

This document has been approved for public release and sale; its distribution is unlimited.



DEPARTMENT OF THE NAVY
NAVY EXPERIMENTAL DIVING UNIT
PANAMA CITY, FLORIDA 32407

6

IN REPLY REFER TO:

10011

17 (NEDU-6-91)

NAVY EXPERIMENTAL DIVING UNIT

REPORT NO. 6-81

MARKET SURVEY AND ANALYSIS OF
COMMERCIALY AVAILABLE FLOWMETERS
FOR THE MK 12 SSDS - AIR MODE

10 ERIC/RANDALL

11 AUG 1981

25 38

10011

Submitted by:

Eric H. Randall

ERIC RANDALL
ENS, USN

Reviewed by:

S.F. Cwiklinski

S.F. CWIKLINSKI
CDR, USN
Executive Officer

Approved by:

R.A. Bornholdt

R. A. BORNHOLDT
CDR, USN
Commanding Officer

20310

UNCLASSIFIED

SECURITY CLASSIFICATION OF THIS PAGE (When Data Entered)

REPORT DOCUMENTATION PAGE		READ INSTRUCTIONS BEFORE COMPLETING FORM
1. REPORT NUMBER 6-81	2. GOVT ACCESSION NO. AD-A105611	3. RECIPIENT'S CATALOG NUMBER
4. TITLE (and Subtitle) MARKET SURVEY AND ANALYSIS OF COMMERCIALY AVAILABLE FLOWMETERS FOR THE MK 12 SSDS - AIR MODE	5. TYPE OF REPORT & PERIOD COVERED Survey	
	6. PERFORMING ORG. REPORT NUMBER	
7. AUTHOR(s) ERIC RANDALL	8. CONTRACT OR GRANT NUMBER(s)	
9. PERFORMING ORGANIZATION NAME AND ADDRESS NAVY EXPERIMENTAL DIVING UNIT PANAMA CITY, FLORIDA 32407	10. PROGRAM ELEMENT, PROJECT, TASK AREA & WORK UNIT NUMBERS	
11. CONTROLLING OFFICE NAME AND ADDRESS	12. REPORT DATE August 1981	
	13. NUMBER OF PAGES 31	
14. MONITORING AGENCY NAME & ADDRESS (if different from Controlling Office)	15. SECURITY CLASS. (of this report) Unclassified	
	15a. DECLASSIFICATION/DOWNGRADING SCHEDULE	
16. DISTRIBUTION STATEMENT (of this Report) Approved for public release; distribution unlimited		
17. DISTRIBUTION STATEMENT (of the abstract entered in Block 20, if different from Report)		
18. SUPPLEMENTARY NOTES		
19. KEY WORDS (Continue on reverse side if necessary and identify by block number) ACFM, SCFM, E.R., PSI, PSIA, PSIG, Pn, Vn, Vn		
20. ABSTRACT (Continue on reverse side if necessary and identify by block number) This report is a market survey and analysis of commercially available flowmeters for possible use with the MK 12 Surface-Supported Diving System (SSDS) - air mode. It was found that a differential pressure-type flowmeter met the listed specifications most completely. A mechanical flowmeter could not be located for less than \$400.00. Also, no flowmeter could be found which did not require some type of conversion table.		

DD FORM 1 JAN 73 1473

EDITION OF 1 NOV 68 IS OBSOLETE
S/N 0102-014-6601

UNCLASSIFIED
SECURITY CLASSIFICATION OF THIS PAGE (When Data Entered)

SECURITY CLASSIFICATION OF THIS PAGE(When Data Entered)

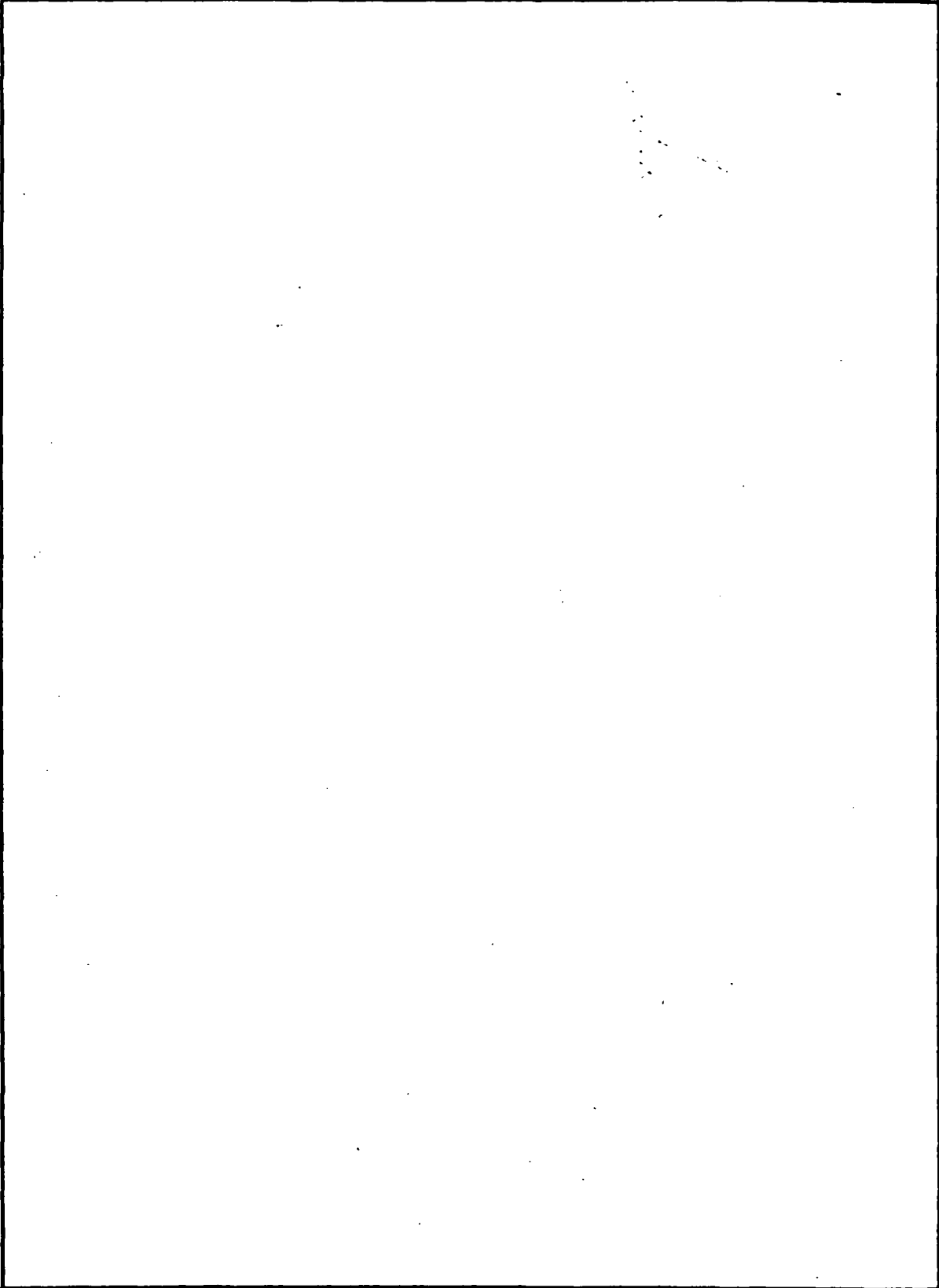

SECURITY CLASSIFICATION OF THIS PAGE(When Data Entered)

Table of Contents

	<u>Page</u>
Report Documentation Page.....	ii
Table of Contents.....	iii
Glossary.....	iv
Abstract.....	v
 <u>Section</u>	
I. INTRODUCTION.....	1
II. SPECIFICATIONS.....	1
III. DISCUSSION.....	1
IV. CONCLUSION.....	3
V. EXPANSION RATIO.....	3
VI. CALCULATIONS.....	6
Figure 1 - Specifications: Flowmeters for MK 12 SSDS - Air Mode.....	4
Appendix A - List of Companies Surveyed.....	A-1 thru A-3
Appendix B - Table of Surface Air Flows.....	B-1 thru B-9
Appendix C - Representative Product Information for the Five Types of Flowmeters Studied.....	C-1 thru C-13

Accession For	
NTIS	<input checked="" type="checkbox"/>
DTIC TAB	<input type="checkbox"/>
Unannounced	<input type="checkbox"/>
Justification	<input type="checkbox"/>
By _____	
Distribution/	
Availability Codes	
Dist	Special
A	

Glossary

ACFM	Actual Cubic Feet Per Minute
SCFM	Standard Cubic Feet Per Minute
E.R.	Expansion Ratio
PSI	Pounds Per Square Inch
PSIA	Pounds Per Square Inch Absolute
PSIG	Pounds Per Square Inch Gauge
P_n	Pressure at 'n'
V_n	Volume at 'n'
\dot{V}_n	Volume Rate of Flow at 'n'

Abstract

This report is a market survey and analysis of commercially available flowmeters for possible use with the MK 12 Surface-Supported Diving System (SSDS) - air mode. It was found that a differential pressure-type flowmeter met the listed specifications most completely. A mechanical flowmeter could not be located for less than \$400.00. Also, no flowmeter could be found which did not require some type of conversion table.

I. INTRODUCTION

The MK 12 Surface-Supported Diving System (SSDS) may be required to have a simple, rugged, accurate and inexpensive flowmeter to monitor, from the surface, the amount of air a diver is receiving on the bottom. The flowmeters capabilities for measurement should be such that it can work at a variety of temperatures and pressures without having to be recalibrated, and should have a meaningful scale (ACFM or SCFM). This report is a market survey for such a flowmeter with an explanation of why different types are or are not desirable.

II. SPECIFICATIONS

1. 1/2 inch minimum inside diameter to match umbilical
2. Minimum working pressure - 60 psia
3. Maximum working pressure plus 10 percent - 275 psia
4. Flow measurement range - 0.25 - 6.0 ACFM,
or 2.0 - 85 SCFM
5. Work in a multi-angular environment
6. Temperature range - 0 - 120°F preferred
20 - 100°F acceptable
7. Material - resistant to a seawater environment
8. Accuracy - ± 5.0 percent of full scale
9. Totally mechanical if possible
10. Price - under \$200.00 per unit preferred
11. Be able to read out in ACFM or SCFM without a conversion chart for varying input pressures and temperatures
12. Durable and reliable

III. DISCUSSION

Presently the Navy's MK 12 SSDS has a Laminar Flow Element-type flowmeter, which reads in inches of water, designated for its use. This flowmeter also has a capsuhelic gauge which is sensitive to the vertical position. This type of readout is confusing to supervisors of MK 12 SSDS diving operations as it does not relate to a standard measure of flow rate, i.e. SCFM or ACFM.

Due to the fact that air is supplied to a diver at 60 psi overbottom pressure for the 200 foot umbilical, 100 psi overbottom pressure for the 600 foot umbilical, and the expansion ratio, an accurate flow of air at the diver is impossible to measure by a mechanical flowmeter. A computer, supplied with the depth of the diver, length of the umbilical, flow-rate of air on the surface and temperature differential of the air between the surface and divers depth, is needed to correlate the data. The expansion ratio is the ratio of the change in volume of a gas as the pressure changes, as stated in Boyle's Law ($P_1V_1 = P_2V_2$). The expansion ratio is explained in more detail in the back of this report.

A viable alternative to this would be a meter which could read out in actual cubic feet of air flow on the surface and through a simple chart, as in Appendix 2, provide the actual air flow to the diver at depth. This method neglects the compressibility of air for a temperature decrease. This will provide a maximum error of approximately 7.39% or 0.44 ACFM for a worst case analysis (see sample calculations on page 6).

There are several types of commercially available flowmeters on the market today which have outputs calibrated in ACFM or SCFM. They may be broken down into five major categories. These are rotameter, float, transducer, turbine and differential pressure-type flowmeters.

The differential pressure-type flowmeter is the best choice with the turbine-type flowmeter following it. The other three categories would not be as suitable for a diving environment.

The following criteria is used to determine the above ranking:

Only one rotameter presently on the market could cover the entire flow range to be measured and it could not meet the maximum pressure requirement of 275 psia.

The float-type flowmeters needed at least two meters to cover the entire flow range, which is an added expense, and most of them could not reach the low end of the scale.

Both the rotameters and the float-type flowmeters could only be calibrated for one temperature and pressure and either need calibration curves or conversion factors for all other pressure and temperature combinations. This would be time consuming and possibly confusing for a busy dive supervisor.

Again, both the rotameters and float-type flowmeters cannot be tilted more than 11° from the vertical or their accuracy is nullified due to their design. This could result in an error of up to 100 percent in the readout. (This would cause a severe problem on a diving platform in anything but a calm sea.)

The transducer-type flowmeters are fragile and bulkier than the other types of flowmeters because of their electronic circuitry. As well as being susceptible to the environment, their cost is prohibitive. However, they can measure air flows over a wide range of temperatures and pressures with good accuracy.

The turbine-type flowmeters are compact, totally mechanical, insensitive to the environment and accurate over the entire range of pressures and temperatures. The problem with them lies in the expensive and fragile electronic readouts that are required.

The differential pressure-type of flowmeter is the best choice. It is simple, inexpensive, on a relative scale, totally mechanical, and its accuracy is unaffected by varying pressures and temperatures. It is also unaffected by a multi-angular environment with respect to the vertical.

For a more detailed analysis of different models of flowmeters, see Figure 1. Material on different model flowmeters is in Appendix 3.

IV. CONCLUSION

From the market survey conducted, it is clear that a differential pressure-type flowmeter is a viable alternative for the MK 12 SSDS. A mechanical gauge should be used in conjunction with this flowmeter to provide a simple, rugged, accurate and inexpensive means to measure the gas flow going to a diver.

The Ellison Model AWR-71 Flowsensor (1/2") with an Eagle Eye D.P. flowmeter is the best suited product for this application. NEDU will purchase and test this flowmeter.

FIGURE 1
SPECIFICATIONS: FLOWMETERS FOR MK 12 SDDS - AIR MODE

COMPANY	TYPE METER (MODEL)	I.D.	MAXIMUM PRESSURE (PSIA)	FLOW RANGE	TOTALLY MECH.	ACCURACY	MATERIAL	MULTI-ANGULAR ENVIRONMENT	READ-OUT TYPE	TEMP. RANGE	PRICE	REMARKS
BROOKS INSTRUMENT DIVISION	FLOAT (3604-D)	1/2"	7300	2-20 SCFM 12-120 SCFM	YES	+ 5%	STAINLESS STEEL	NO- 11° MAX TILT FROM VERTICAL	MECH. GAUGE	32-400°F	\$300/EA	NEED 2 TO COVER FLOW RANGE; CANNOT WITH-STAND NON-VERTICAL ORIENTATION
COX INSTRUMENTS	TURBINE (GAS SERIES)	1/2"	7300	.75-3 ACFM 1.5-7 ACFM	YES	+ 3%	STAIN-LESS STEEL	YES	ELEC. READOUT	----	\$800/EA WITH READOUT	NEED MORE THAN 1; CANNOT MEASURE LOW ENOUGH FLOW RATE
ELLISON INSTRUMENT DIVISION	DIFFERENTIAL PRESSURE (AWR-61)	3/4"	1000	0-8 ACFM	YES	+ 3%	STAINLESS STEEL/W BRASS VALVES	YES	MECH. GAUGE	-200-1200°F	\$700/EA	BEST - MEETS ALL SPECIFICATIONS
FISCHER & PORTER	TURBINE (1052000)	1"	275	.7-25 ACFM	YES	+ 1%	STAINLESS STEEL	YES	ELEC. READOUT	-40-100°F	\$3-400/EA	COST TOO MUCH; FLOW SCALE NOT LOW ENOUGH
FLOW TECH. INC.	TURBINE (FT. 6-8)	1/2"	300	.25-5 ACFM	YES	+ .5%	STAINLESS STEEL	YES	ELEC. READOUT	-430-720°F	\$1200/EA	COST TOO MUCH
MERIAM INSTRUMENT COMPANY	LINEAR FLOW ELEMENT (50MW20-2)	1/2"	200	-----	YES	+ .5%	STAINLESS STEEL	YES	MECH. GAUGE	?-154°F	\$570/EA	MAXIMUM PRESSURE NOT HIGH ENOUGH
MIDWEST INSTRUMENT COMPANY	DIFFERENTIAL PRESSURE	--	300	*.25-5 ACFM	YES	----	STAINLESS STEEL	YES	----	----	----	* NEED A SEPARATE GAUGE PACKAGE TO READ DESIRED FLOW
RCA INDUSTRIES INC.	DIFFERENTIAL PRESSURE	1/2"	400 (SPECIAL)	1.5-10 SCFM 10-80 SCFM	YES	+ 3%	STAINLESS STEEL	YES	MECH. GAUGE	----	\$309.50 EA	NEED CORRECTION FACTOR; 2 GAUGES, & STILL WON'T COVER HIGH END OF FLOW SCALE
TELEDYNE HASTINGS RAYDIST	TRANSDUCER	--	275	0-5.0 ACFM	NO - ELEC.	+ 2%	----	YES	ELEC. READOUT	----	\$2365/EA	COST TOO MUCH; TOO DELICATE

V. EXPANSION RATIO

The expansion ratio (E.R.) is a number which relates the change in the volume of a gas as it goes from a high pressure to a low pressure. This is a product of Boyle's Law, $PV = C$, or Charle's Law, $PV/T = K$, if the effects of temperature are included.

An example would be: a diver at 100 FSW must receive 6 ACFM of air to purge his helmet of CO_2 . The pressure at 100 FSW is 59.2 psia. The gas (air) is supplied from the surface at 100 psia overbottom pressure for the divers 600 foot umbilical, therefore the supply pressure is 159.2 psia at the surface. From Boyle's Law, the volume rate of flow at the surface must be less than at the divers depth.

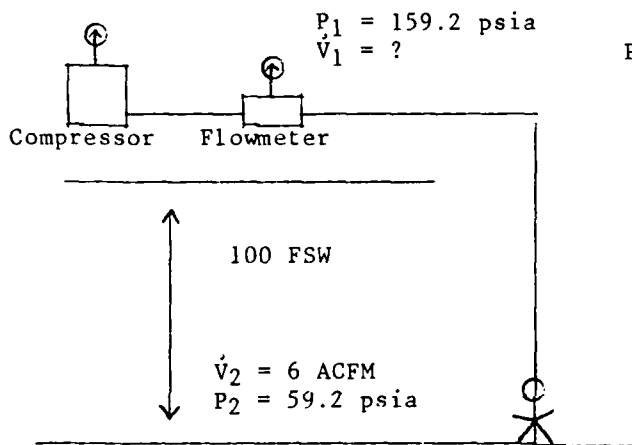

$$P_1 V_1 = P_2 V_2$$

$$V_1 = \frac{P_2 V_2}{P_1}$$

$$\frac{V_1}{V_2} = \frac{P_2}{P_1} = \frac{1}{\text{E.R.}}$$

$$\frac{P_1}{P_2} = \frac{159.2}{59.2} = 2.68 = \text{E.R.}$$

$$\therefore (\dot{V}_1) (\text{E.R.}) = V_2$$

$$\therefore \dot{V}_1 = \frac{6 \text{ ACFM}}{2.68}$$

$$\therefore \dot{V}_1 = \underline{2.24 \text{ ACFM}}$$

This principle may also be illustrated with a 72 cubic foot steel SCUBA tank which has a floodable volume of 700 in^3 or 0.4051 ft^3 ; at 2250 psi this bottle holds the equivalent of 62.4 ft^3 of gas at atmospheric pressure.

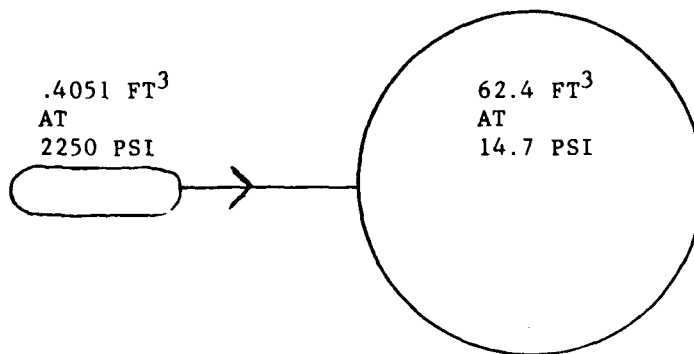

VI. CALCULATIONS

EXPLANATION OF SCFM AND ACFM:

$$\text{SCFM} = \Delta P \text{ (ATA)} \times \text{ACFM (Flow Entering Meter)}$$
$$\Delta P = (P_1 - P_2) = (P_1 - 1 \text{ ATA})$$

$$\text{ACFM} = \Delta P \text{ (ATA)} \times \text{CFM (Flow Entering Meter)}$$
$$P_2 = P_1 \therefore \Delta P = 1.0$$

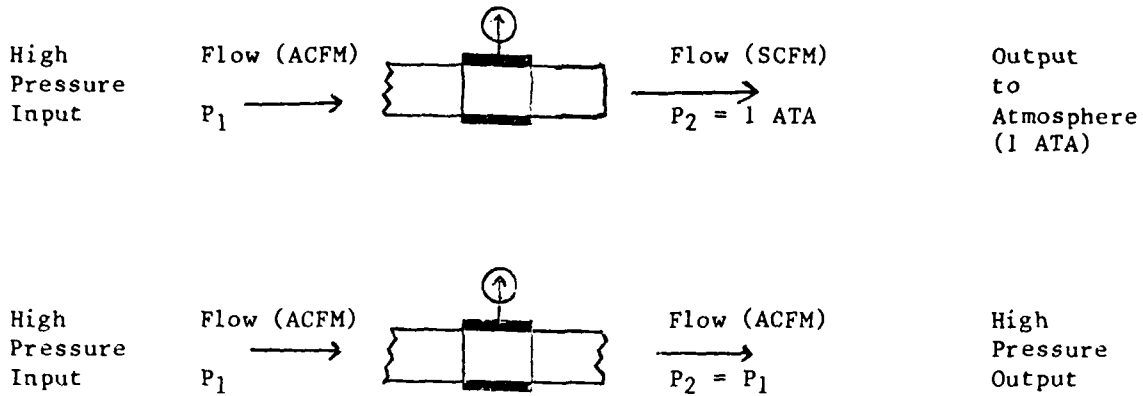

SCFM measures gas flow with respect to 1 ATA of pressure.

ACFM measures gas flow with respect to the ambient gas pressure.

A worst case analysis for the expansion of air through a pressure differential, neglecting a temperature differential.

$$T_{\text{Surface}} = 70^{\circ}\text{F} = 530^{\circ}\text{R}$$

$$T_{\text{Depth}} = 30^{\circ}\text{F} = 490^{\circ}\text{R}$$

$$P_5 = 248.33 \text{ psia}$$

$$P_0 = 148.33 \text{ psia}$$

$$\text{Depth} = 300 \text{ FSW}$$

$$\dot{V}_S = 3.59 \text{ ACFM}$$

$$\dot{V}_D = ? \quad \text{Should be 6 ACFM with no } \Delta T$$

By Charles Law:

$$\frac{P_1 V_1}{T_1} = \frac{P_2 V_2}{T_2}$$

$$\frac{(248.33) (3.59)}{530} = \frac{(148.33) (\dot{V}_D)}{490}$$

$$\dot{V}_D = 5.56 \text{ ACFM}$$

$$\Delta \dot{V} = .44 \text{ ACFM} = 7.39\% \quad \text{Due to neglecting temperature considerations}$$

APPENDIX A
LIST OF COMPANIES SURVEYED

APPENDIX A

LIST OF COMPANIES SURVEYED

Brooks Instrument Division, Emerson Electrical Company
Hatfield, PA 19440
215-362-3500

Cole-Palmer Instrument Company
7425 North Oak Park Avenue
Chicago, IL 60648
1-800-323-4340

Cox Instruments
15300 Fullerton
Detroit, MI 48227
313-838-5780

Erdco Engineering Corporation
136-T Official Road
Addison, IL 60101
312-328-0550

Ellison Instrument Division
Factory Representative:
Control Center
1013 E. Montana Street
Orlando, FL 32803
305-896-6831

Fischer & Porter
County Line Road
Warminster, PA 18974
215-674-6000

Flow Technology, Inc.
Factory Representative:
Paul A. Quinn Associates
P.O. Box 14217
Tampa, FL 33690
813-254-5211

McMaster-Carr Supply Co.
P.O. Box 4355
Chicago, IL 60680
312-834-9600

APPENDIX A

LIST OF COMPANIES SURVEYED (continued)

Meriam Instrument Company
Factory Representative:
Diller, Brown and Associates
Jacksonville, FL
904-269-9405

Mid-West Instrument Company
286-T Executive Drive
Troy, MI
313-585-0900

RCM Industries, Inc.
P.O. Box 351
Orinda, CA 94563
415-687-8363

Teledyne Hastings-Ray Dist
P.O. Box 1275
Hampton, VA 23361
804-723-6531

TSI Inc.
P.O. Box 43394
St. Paul, MN 55614
612-483-0900

Universal Flow Monitors
1755 East Nine Mile Road
Hazel Park, MI 48030
1-800-521-6382

APPENDIX B

TABLE OF SURFACE AIR FLOWS

APPENDIX B

TABLE OF SURFACE (LFE) ACFM TO ACHIEVE
2, 4 AND 6 ACFM AT DEPTH
E.R. = EXPANSION RATIO

The following table will have to be used in conjunction with any flowmeter designated for use with a diving rig. For each depth, desired flow rate at the divers helmet, and overbottom pressure, the actual flow on the surface must be cross-referenced from this table.

Example: A diver is at 100 FSW with a 60 PSI overbottom pressure doing heavy work. To supply him with 6 ACFM of air at the bottom, 2.99 ACFM of air must be registered on the flowmeter on the surface.

<u>ACFM AT HELMET</u>	<u>*ACFM AT 60 PSI OVER BOTTOM PRESSURE</u>	<u>*ACFM AT 100 PSI OVER BOTTOM PRESSURE</u>
<u>DEPTH: 0 FSW</u>	<u>E.R. = 5.08</u>	<u>E.R. = 7.80</u>
2	$2/5.08 = .40$	$2/7.80 = .26$
4	$4/5.08 = .79$	$4/7.80 = .51$
6	$6/5.08 = 1.18$	$6/7.80 = .77$
<u>DEPTH: 10 FSW</u>	<u>E.R. = 4.13</u>	<u>E.R. = 6.22</u>
2	.49	.32
4	.97	.64
6	1.45	.97
<u>DEPTH: 20 FSW</u>	<u>E.R. = 3.54</u>	<u>E.R. = 5.24</u>
2	.56	.38
4	1.13	.76
6	1.69	1.15

APPENDIX B

TABLE OF SURFACE (LFE) ACFM TO ACHIEVE
2, 4 AND 6 ACFM AT DEPTH (continued)
E.R. = EXPANSION RATIO

<u>ACFM AT HELMET</u>	<u>*ACFM AT 60 PSI OVER BOTTOM PRESSURE</u>	<u>*ACFM AT 100 PSI OVER BOTTOM PRESSURE</u>
<u>DEPTH: 30 FSW</u>		
	<u>E.R. = 3.14</u>	<u>E.R. = 4.56</u>
2	.637	.44
4	1.27	.87
6	1.91	1.31
<u>DEPTH: 40 FSW</u>		
	<u>E.R. = 2.85</u>	<u>E.R. = 4.07</u>
2	.70	.49
4	1.40	.98
6	2.10	1.47
<u>DEPTH: 50 FSW</u>		
	<u>E.R. = 2.62</u>	<u>E.R. = 3.71</u>
2	.76	.54
4	1.53	1.08
6	2.29	1.62
<u>DEPTH: 60 FSW</u>		
	<u>E.R. = 2.45</u>	<u>E.R. = 3.41</u>
2	.82	.59
4	1.63	1.17
6	2.45	1.76

APPENDIX B

TABLE OF SURFACE (LFE) ACFM TO ACHIEVE
2, 4 AND 6 ACFM AT DEPTH (continued)
E.R. = EXPANSION RATIO

<u>ACFM AT HELMET</u>	<u>*ACFM AT 60 PSI OVER BOTTOM PRESSURE</u>	<u>*ACFM AT 100 PSI OVER BOTTOM PRESSURE</u>
<u>DEPTH: 70 FSW</u>	<u>E.R. = 2.31</u>	<u>E.R. = 3.18</u>
2	.86	.63
4	1.73	1.26
6	2.59	1.89
<u>DEPTH: 80 FSW</u>	<u>E.R. = 2.19</u>	<u>E.R. = 2.99</u>
2	.91	.67
4	1.83	1.34
6	2.74	2.00
<u>DEPTH: 90 FSW</u>	<u>E.R. = 2.09</u>	<u>E.R. = 2.83</u>
2	.96	.74
4	1.91	1.41
6	2.87	2.12
<u>DEPTH: 100 FSW</u>	<u>E.R. = 2.01</u>	<u>E.R. = 2.69</u>
2	.99	.74
4	1.99	1.49
6	2.99	2.23

APPENDIX B

TABLE OF SURFACE (LFE) ACFM TO ACHIEVE
2, 4 AND 6 ACFM AT DEPTH (continued)
E.R. = EXPANSION RATIO

<u>ACFM AT HELMET</u>	<u>*ACFM AT 60 PSI OVER BOTTOM PRESSURE</u>	<u>*ACFM AT 100 PSI OVER BOTTOM PRESSURE</u>
<u>DEPTH: 110 FSW</u>		
	<u>E.R. = 1.94</u>	<u>E.R. = 2.57</u>
2	1.03	.78
4	2.06	1.56
6	3.07	2.33
<u>DEPTH: 120 FSW</u>		
	<u>E.R. = 1.88</u>	<u>E.R. = 2.47</u>
2	1.06	.81
4	2.13	1.62
6	3.19	2.43
<u>DEPTH: 130 FSW</u>		
	<u>E.R. = 1.83</u>	<u>E.R. = 2.38</u>
2	1.09	.84
4	2.18	1.68
6	3.28	2.52
<u>DEPTH: 140 FSW</u>		
	<u>E.R. = 1.78</u>	<u>E.R. = 2.30</u>
2	1.12	.87
4	2.25	1.74
6	3.37	2.61

APPENDIX B

TABLE OF SURFACE (LFE) ACFM TO ACHIEVE
2, 4 AND 6 ACFM AT DEPTH (continued)
E.R. = EXPANSION RATIO

<u>ACFM AT HELMET</u>	<u>*ACFM AT 60 PSI OVER BOTTOM PRESSURE</u>	<u>*ACFM AT 100 PSI OVER BOTTOM PRESSURE</u>
<u>DEPTH: 150 FSW</u>	<u>E.R. = 1.74</u>	<u>E.R. = 2.23</u>
2	1.15	.90
4	2.30	1.79
6	3.45	2.69
<u>DEPTH: 160 FSW</u>	<u>E.R. = 1.70</u>	<u>E.R. = 2.16</u>
2	1.18	.92
4	2.35	1.85
6	3.53	2.78
<u>DEPTH: 170 FSW</u>	<u>E.R. = 1.66</u>	<u>E.R. = 2.11</u>
2	1.20	.95
4	2.41	1.89
6	3.61	2.84
<u>DEPTH: 180 FSW</u>	<u>E.R. = 1.63</u>	<u>E.R. = 2.05</u>
2	1.23	.97
4	2.45	1.95
6	3.68	2.93

APPENDIX B

TABLE OF SURFACE (LFE) ACFM TO ACHIEVE
2, 4 AND 6 ACFM AT DEPTH (continued)
E.R. = EXPANSION RATIO

<u>ACFM AT HELMET</u>	<u>*ACFM AT 60 PSI OVER BOTTOM PRESSURE</u>	<u>*ACFM AT 100 PSI OVER BOTTOM PRESSURE</u>
<u>DEPTH: 190 FSW</u>		
	<u>E.R. = 1.60</u>	<u>E.R. = 2.01</u>
2	1.25	.99
4	2.50	1.99
6	3.75	2.98
<u>DEPTH: 200 FSW</u>		
	<u>E.R. = 1.58</u>	<u>E.R. = 1.96</u>
2	1.26	1.02
4	2.53	2.04
6	3.80	3.06
<u>DEPTH: 210 FSW</u>		
	LIMIT OF 200' UMBILICAL	<u>E.R. = 1.92</u>
2		1.04
4		2.08
6		3.12
<u>DEPTH: 220 FSW</u>		
		<u>E.R. = 1.89</u>
2		1.05
4		2.12
6		3.17

APPENDIX B

TABLE OF SURFACE (LFE) ACFM TO ACHIEVE
2, 4 AND 6 ACFM AT DEPTH (continued)
E.R. = EXPANSION RATIO

<u>ACFM AT HELMET</u>	<u>*ACFM AT 100 PSI OVER BOTTOM PRESSURE</u>
<u>DEPTH: 230 FSW</u>	
	<u>E.R. = 1.85</u>
2	1.08
4	2.16
6	3.24
<u>DEPTH: 240 FSW</u>	
	<u>E.R. = 1.82</u>
2	1.10
4	2.20
6	3.30
<u>DEPTH: 250 FSW</u>	
	<u>E.R. = 1.79</u>
2	1.12
4	2.23
6	3.35
<u>DEPTH: 260 FSW</u>	
	<u>E.R. = 1.77</u>
2	1.13
4	2.26
6	3.39

APPENDIX B

TABLE OF SURFACE (LFE) ACFM TO ACHIEVE
2, 4 AND 6 ACFM AT DEPTH (continued)
E.R. = EXPANSION RATIO

<u>ACFM AT HELMET</u>	<u>*ACFM AT 100 PSI OVER BOTTOM PRESSURE</u>
<u>DEPTH: 270 FSW</u>	
	<u>E.R. = 1.74</u>
2	1.15
4	2.30
6	3.45
<u>DEPTH: 280 FSW</u>	
	<u>E.R. = 1.72</u>
2	1.16
4	2.32
6	3.49
<u>DEPTH: 290 FSW</u>	
	<u>E.R. = 1.69</u>
2	1.18
4	2.37
6	3.55
<u>DEPTH: 300 FSW</u>	
	<u>E.R. = 1.67</u>
2	1.20
4	2.39
6	3.59

* 60 PSI OVER BOTTOM PRESSURE IS USED WITH THE 200 FOOT UMBILICAL

* 100 PSI OVER BOTTOM PRESSURE IS USED WITH THE 600 FOOT UMBILICAL

APPENDIX C

REPRESENTATIVE PRODUCT INFORMATION FOR
THE FIVE TYPES OF FLOWMETERS STUDIED

EAGLE EYE MAKES

FLOW AND FILTER METER SYSTEMS

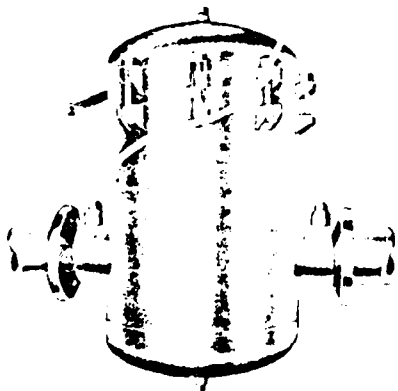
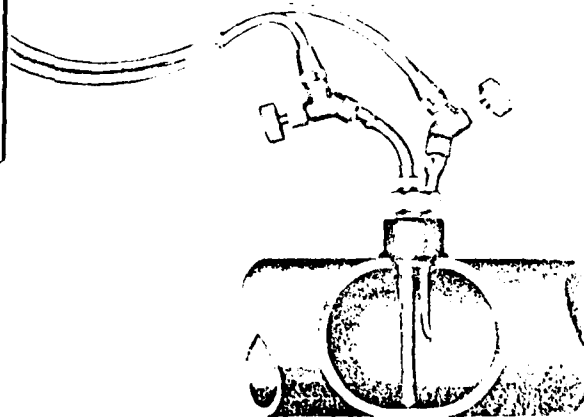
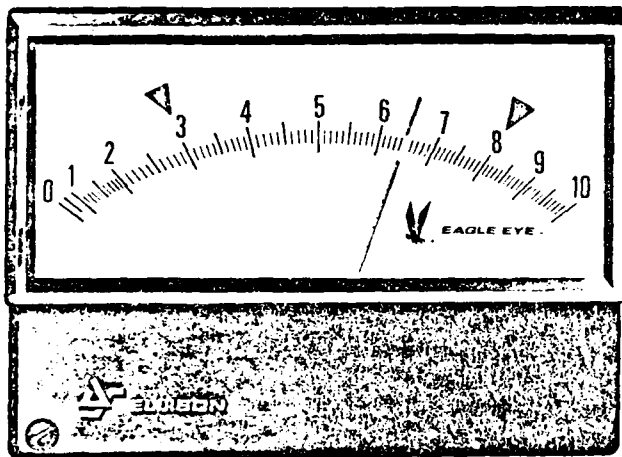

FILTER METERS

They are used to accurately monitor the contamination level across all types of filters. Only with dependable accuracy can filter cleaning or replacement cycle be optimized.

FLOW METER

Only Annubar Flow Sensors* are used with EAGLE EYE Meters* to complete EAGLE EYE Flow Meter Sets.

The patented Annubar sensor is a thoroughly dependable flow element, proven in tens of thousands of industrial and commercial applications.

Annubars are approved by applicable specifications and codes, including United States Government (GSA Specification PBS: 4-1590).

*Patents and trademarks for both Eagle Eye and Annubar are issued or pending worldwide.



TECHNICAL & ORDERING DATA

TYPE 71 & 72

SENSOR WITH FACTORY INSTALLED SENSING PROBES SUPPLIED IN PIPE NIPPLE.

- 71 - SCHEDULE 40 PIPE NIPPLE
- 72 - SCHEDULE 80 PIPE NIPPLE

APPLICATIONS:
STANDARD THREADED PIPES - SUPPLIED WITH MALE NPT THREADS FOR MOUNTING

FITTINGS AVAILABLE FOR 710 & 720:

- #1 - 1/2" NPT
- #2 - 3/4" NPT
- #3 - 1" NPT
- #4 - 1/2" COMPRESSION ADAPTER
- #5 - BRASS VALVE WITH 1/4" SAE FLARE
- #6 - 303SS VALVE WITH 1/8" FEMALE NPT CONNECTIONS

AVAILABLE MATERIALS:

- 316SS
 - HASTELLOY C (TYPE 71 ONLY, #3 FITTING ONLY)
 - TITANIUM (TYPE 71 ONLY, #3 FITTING ONLY)
- Availability of these materials on request*

REQUEST DRAWING E-164

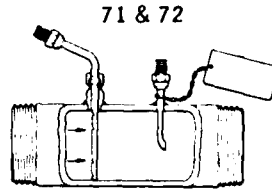

TYPE 71
PIPE SIZES 1/2" to 2 1/2"

TYPE 72
PIPE SIZES 1/2" to 2 1/2"



MAX. D.P. CHART	
PIPE SIZES	TYPE 71-72
1/2" to 2 1/2"	250" (18-390)

1. Max. D.P.'s shown in inches H₂O, and apply to all measured fluids.
2. Max. water flow rates in G.P.M. shown in parenthesis.
3. Max. flow rates for other fluids - use equivalent p. 17 & 18.

TEMPERATURE PRESSURE RATINGS

TYPES 711-714 CHART C

PIPE SIZES	MATERIALS	CURVE LETTER
1/2" to 2 1/2"	316SS	A
	Hastelloy C	F
	Monel 400	H
	Titanium (Ti-6Al-4V)	L
1/2" to 2 1/2"	316SS	M
	Hastelloy C	N
	Monel 400	P
	Titanium (Ti-6Al-4V)	Q
1/2" to 2 1/2"	316SS	R
	Hastelloy C	S
	Monel 400	T
	Titanium (Ti-6Al-4V)	U

TYPES 721-724 CHART D

PIPE SIZES	MATERIALS	CURVE LETTER
1/2" to 2 1/2"	316SS	K
	Hastelloy C	E
	Monel 400	G
	Titanium (Ti-6Al-4V)	I
1/2" to 2 1/2"	316SS	M
	Hastelloy C	N
	Monel 400	P
	Titanium (Ti-6Al-4V)	Q
1/2" to 2 1/2"	316SS	R
	Hastelloy C	S
	Monel 400	T
	Titanium (Ti-6Al-4V)	U

Maximum temperature ratings are based on a maximum flow rate of 10 G.P.M. for all pipe sizes. For other flow rates, refer to the equivalent pressure ratings chart for the type of material used.

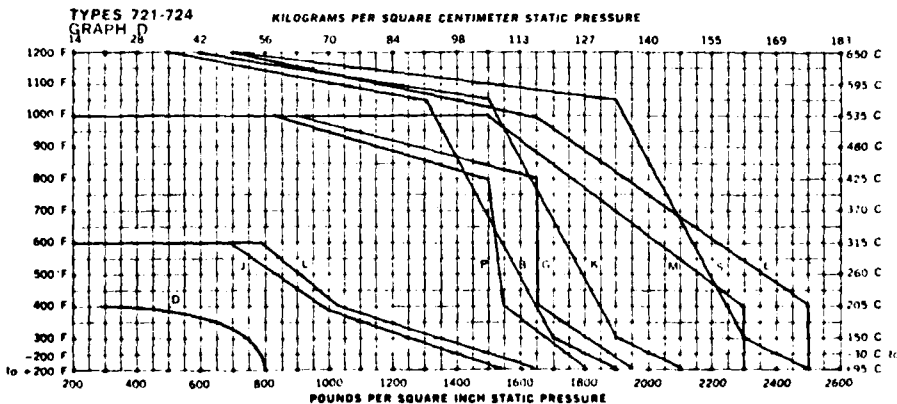
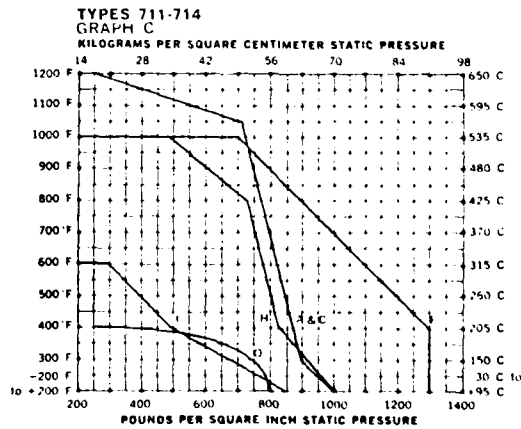



BETTER ENGINEERING . . .

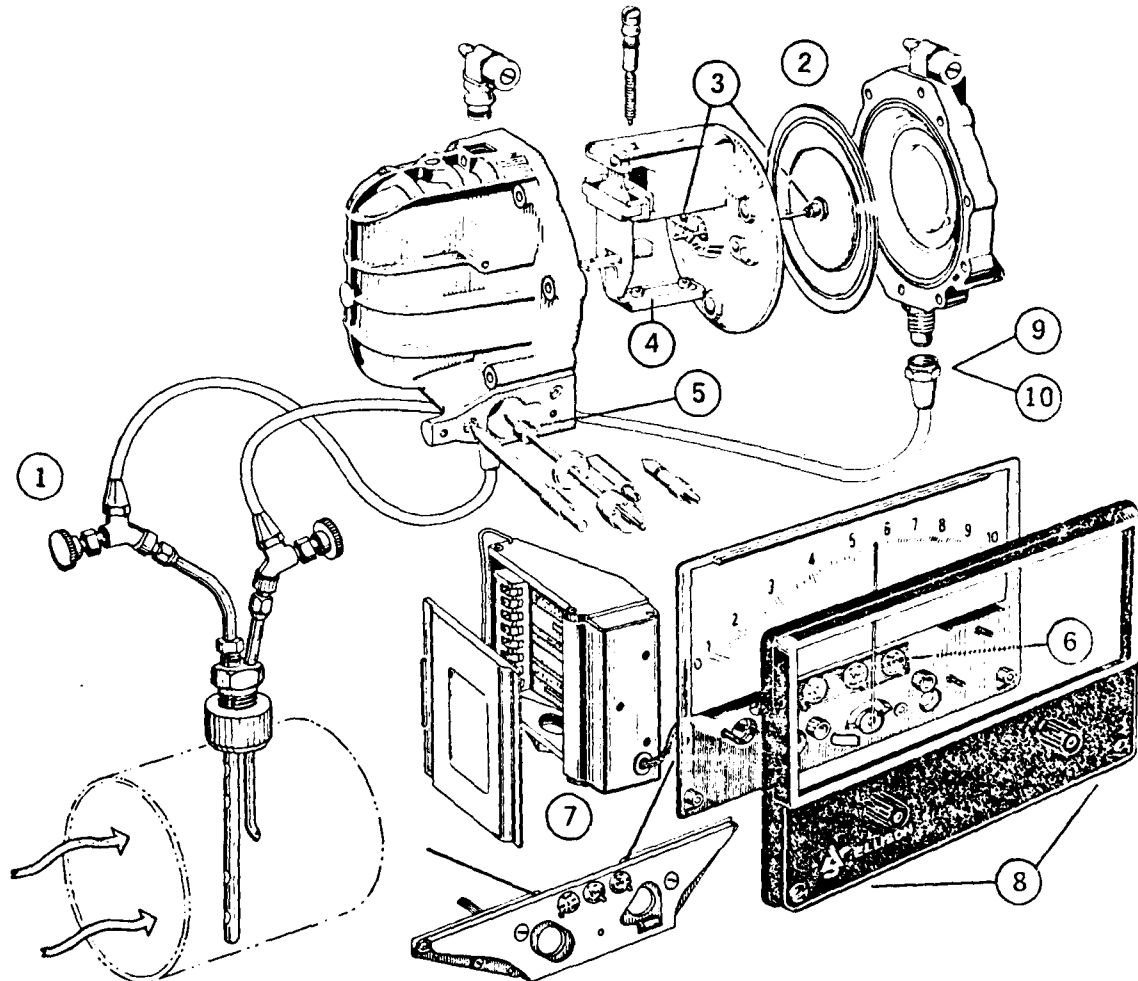

HERE'S HOW IT WORKS . . .

- ① **INPUT SIGNAL**—All EAGLE EYE Flow Meter Sets use the patented Annubar Flow Sensor to detect the rate of flow being measured.

For applications other than flow, the EAGLE EYE D.P. Meter is recommended. It is used for measuring filter contamination, pump performance, tank levels and many other input signals.

- ② **TRANSDUCER** — The input signal is carried to the EAGLE EYE Meter through standard tubing. Here one signal is applied to each side of the low displacement diaphragm. The diaphragm senses the difference in pressures and produces axial motion. None of the measured fluid ever contacts the indication section of the meter.

PRODUCT DATA from FLOW TECHNOLOGY, INC.

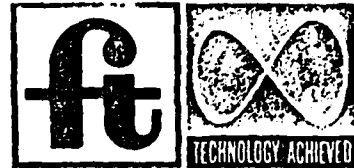

4250 EAST BROADWAY ROAD ■ P.O. BOX 21346 ■ PHOENIX, ARIZONA 85036 ■ PHONE (602) 268-8776 ■ TELEX 668-344

STANDARD LINE TURBINE FLOWMETERS

- FLOW RATES FROM 0.03 TO 20,000 GALLONS PER MINUTE
- LIQUID OR GAS MEASUREMENT
- TEMPERATURES FROM -430°F. TO $+750^{\circ}\text{F.}$
- HIGH ACCURACY
- DYNAMIC FLUID THRUST BEARING
- HIGH OVERSPEED CAPABILITY
- LOW MASS ROTOR FOR HIGH DYNAMIC RESPONSE, LONG BEARING LIFE
- WIDE CHOICE OF MATERIALS
- ADDED SAFETY OF BOTH UPSTREAM AND DOWNSTREAM ROTOR SUPPORTS
- LOW PRESSURE DROP

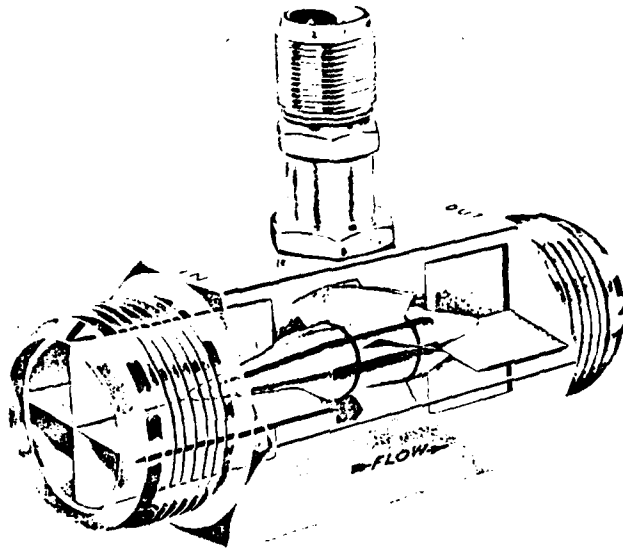

OVER 25 YEARS OF TURBINE FLOWMETER EXPERIENCE GOES INTO EVERY FTI TURBINE FLOWMETER

FLOW TECHNOLOGY, INC. engineers helped develop the first axial turbine flowmeters over 25 years ago. Because of continual development and improvement, FTI's turbine flowmeters have paced the state of the art. Fluid flow measurement is FTI's only business; we have to be very good at it.

GENERAL DESCRIPTION

Basically the FLOW TECHNOLOGY, INC. Standard Line Turbine Flowmeter is a miniature propeller suspended in a pipe. This freely-suspended axial turbine is rotated by the flow of fluid — gas or liquid — through the flowmeter. The rotational speed of the turbine is proportional to the velocity of the fluid. Since the flow passage is fixed, the turbine's rotational speed is also a true representation of the volume of fluid flowing through the flowmeter. This volume can be expressed as gallons per minute, liters per minute, cubic feet per minute, or various other engineering units.

This idea is very old. Flowmeters based on the water wheel, a similar principle, have been used for centuries. However, modern technology has developed the turbine flowmeter to an outstanding level of accuracy, linearity, durability and reliability.

There is no direct physical connection other than the turbine bearings between the turbine and its housing. The rotation of the turbine is sensed through the flowmeter body by an ex-

ternally mounted pickoff on the surface directly above the flowmeter rotor. The rotation of this turbine rotor produces a train of electrical pulses in the pickoff. The frequency of these pulses is directly proportional to the volume flowrate. The pulses can then be transmitted to appropriate read-out electronics near the flowmeter or at a remote location. They can be amplified, counted, interfaced with computer terminals and used to measure and control fluid flow. The pulse train can be processed in any digital system.

It is necessary to translate the pulses into meaningful information. Flow Technology, Inc. manufactures a complete line of electronic devices for that purpose. These units can display flow rate in any engineering units, either analog or digital. There are also digital totalizers with LED or mechanical counters as well as batch controllers and blind converters which change signals into a format required to interface a customer's built in system.

SIZES & SPECIFICATIONS LIQUID

Model No.	Nominal End Fitting Size (In.)	Normal Flow Range (U.S. GPM)		Extended Flow Range (U.S. GPM)			Approximate ** Frequency Output (CPS)	Approximate "K" Factor Pulses Per Gallon
		Minimum	Maximum	Minimum*		Maximum		
				Journal	Ball			
FT 4 8	1/2	0.25	2.5	0.06	0.03	3	2300	55000
FT 6 8	1/2	0.5	5.0	0.1	0.05	5	2100	25000
FT 8 8	1/2	0.75	7.5	0.16	0.08	8	2000	16000
FT 8	1/2	1.0	10.0	0.2	0.1	10	2000	12000
FT 10	3/8	1.25	12.5	0.2	0.15	15	1700	8300
FT-12	3/4	2.0	20	0.33	0.25	25	2000	6000
FT 16	1	5.0	50	0.6	0.6	60	2000	2400
FT-20	1 1/4	9.0	90	0.9	0.9	90	1950	1300
FT 24	1 1/2	15	150	1.5	1.5	150	1500	600
FT-32	2	20	225	2.5	2.5	250	1300	350
FT-40	2 1/2	30	400	4.5	4.5	450	650	100
FT-48	3	40	650	7.5	7.5	750	812	75
FT 64	4	75	1250	15	15	1500	625	30
FT 80	5	90	2000	25	25	2500	300	9
FT-96	6	130	3000	35	35	3500
FT-128	8	250	5500	60	60	6000
FT-160	10	400	8500	100	100	10000
FT-192	12	550	12000	150	150	15000
FT 224	14	750	16000	200	200	20000

Other sizes available, check with factory.
The above data is based on a liquid with a S.G. of 1 and a viscosity of 1 centistoke.
Flow Rates and Frequencies other than shown available upon request.

* The extended range requires an active (RF) pickoff and a Range Extending Amplifier Model LFA 300 for meters 2" and smaller.
** At maximum of normal flow range. *** Consult factory.

SIZES & SPECIFICATIONS GAS

Model No.	Nominal End Fitting Size (In.)	Normal Flow Range (ACFM)		Extended Flow Range (ACFM)		Approximate ** Frequency Output (CPS)	Approximate "K" Factor Pulses Per Cu. Ft.
		Minimum	Maximum	Minimum	Maximum		
FT 4 8	1/2	0.25	2.5	0.2	3	2300	55000
FT 6 8	1/2	0.5	5.0	0.25	5	2100	25000
FT 8 8	1/2	0.75	7.5	0.4	8	2000	16000
FT 8	1/2	1.0	10.0	0.5	10	2000	12000
FT 10	3/8	1.25	12.5	0.6	15	1700	8300
FT 12	3/4	2	20	1.0	25	2000	6000
FT 16	1	5	50	1.5	60	2000	2400
FT 20	1 1/4	9	90	2.25	90	1950	1300
FT 24	1 1/2	15	150	3.75	150	1500	600
FT 32	2	20	225	5	250	1300	350
FT 40	2 1/2	30	400	9	450	650	100
FT 48	3	40	650	15	750	812	75
FT 64	4	75	1250	30	1500	625	30
FT 80	5	90	2000	50	2500	300	9
FT 96	6	130	3000	70	3500

The above data is based on air at 60°F and 14.7 psi for meters with ball bearings.
** At maximum of normal flow range. *** Consult factory.

Gases with less density will have a more limited range.

PRODUCT DATA
from
FLOW TECHNOLOGY, INC.

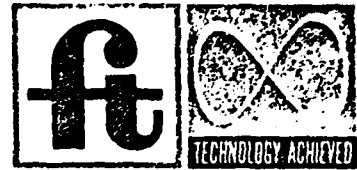

4250 EAST BROADWAY ROAD ■ P.O. BOX 21346 ■ PHOENIX, ARIZONA 85036 ■ PHONE (602) 268-8776 ■ TELEX 668-344

MODEL PRI-3 DIGITAL PULSE RATE INDICATOR

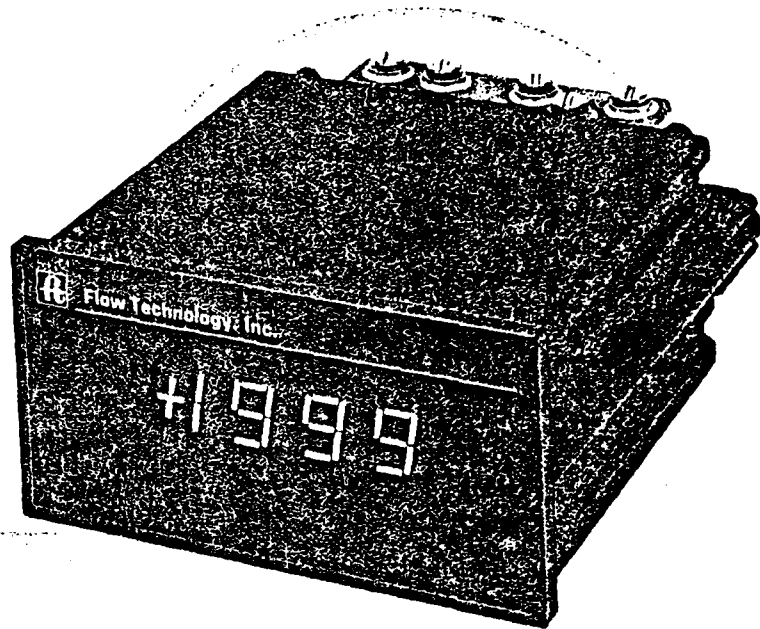

FEATURES

- SELECTIVE ENGINEERING UNITS
- LARGE LED DISPLAY
- COMPACT — LIGHT WEIGHT
- AC OR DC OPERATION
- FRONT PANEL "FINE" TUNING

PRI-3 APPLICATIONS

Process rate, flow, frequency indication and control

Computer controlled data acquisition

Environmental emission rate monitoring

"On board" automotive, marine or aircraft instrumentation

PRI-3 PROGRAMMABLE RATE INDICATOR

The Flow Technology, Inc. Model PRI-3 3 1/2 digit Rate Indicator is designed for rate measurements in engineering units such as feet per minute, gallons per minute, cubic meters per second, liters per second, etc. The unit accepts input signals from pulse and sine wave sources.

Packaging is rugged and light weight because of the compact enclosure. The enclosure is constructed of high-impact plastic which is designed to keep the circuitry free from dust and other contaminants. The digital display is designed for maximum readability. Large bright red LED digits provide easy viewing, and eliminate glare and interpretation problems.

Four power input options are available providing unrestricted usage of the unit world-wide. These options include both AC and DC operation capabilities.

Programming of the Model PRI-3 is accomplished from the front without removing the unit from the case. Function switches are provided for type of input selection, output pulse selection, scaling of the digital display and time response selection. Fine tuning is accomplished from the front by potentiometer adjustment.

The analog output signal is also adjusted from the front of the unit. A separate span potentiometer has been provided for this feature.

PRI-3 SPECIFICATIONS



FUNCTION	DESCRIPTION
SIGNAL INPUT	User selectable for sinewave or pulse input
Configuration	Floating and isolated, DC coupled
Input Impedance	100K ohm in parallel with 1000 pF
Input Frequency	0 to 10 KHz
SINE WAVE INPUT	
Input Voltage	3mVp-p to 300Vp-p
PERFORMANCE	
Accuracy	$\pm 0.05\%$ of reading ± 1 count
Resolution	0.05% for 2000 counts
Time Response	User selectable in 16 steps from 0.35 sec. to 20 sec.
ANALOG TO DIGITAL CONVERSION	
Technique	Dual Slope with automatic zero, 2.5 conversions per sec
OUTPUTS	
Digital Parallel BCD (Optional)	15 Parallel lines provide latched and buffered BCD output, POLARITY, and PRINT command. All are TTL/DTL and CMOS compatible, 2 TTL loads each
PULSE OUT	User selectable for true or inverted output 0 to +5VDC swing, DTL, TTL and CMOS compatible; 3 TTL loads.
ANALOG OUTPUT	
Voltage	0 to +5VDC output
Current	2mA drive capability, short circuit protected
DISPLAY	
Type	Seven segment planar LED, red, 0.43" (11mm) high
POWER	
Choice of 4 Power Inputs	+5VDC $\pm 5\%$ @ 170mA nominal +8 to +28VDC @ 90mA nominal 110 VAC RMS $\pm 20\%$, 47 to 500 Hz @ 1.6 Watts nominal (88 to 132 VAC input range) 220 VAC RMS $\pm 20\%$, 47 to 500 Hz @ 1.6 Watts nominal (176 to 264 VAC input range)
ENCLOSURE	DIN/NEMA standard, high impact molded plastic case
Dimensions	3.79" W x 1.89" H x 4.38" D
Panel Cutout	3.53" x 1.78"
OPTIONS	
Parallel BCD	15 parallel lines provide latched and buffered BCD output, POLARITY and PRINT command. All are TTL/DTL and C mos compatible, 2 TTL loads each.
Enclosure	Metal case same dimensions as plastic for increased RFI immunity
Line Noise Suppressor	Additional AC power line filter for increased RFI immunity
Explosion-Proof	Nelson 7TFW-555 NEMA 7
	6.25" W x 6.25" H x 7.13" D
	Hoffman Fiberglass A-865JFG NEMA 3, 3R, 4, 4X and 13
	8.00" L x 6.5" W x 5.44" D

FOR ADDITIONAL INFORMATION
CONTACT FTI OR YOUR FTI REPRESENTATIVE:

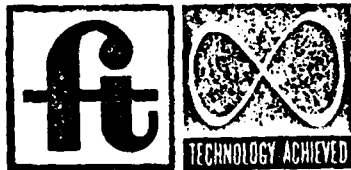

**DESIGN
SPECIFICATIONS**
**Hi-Pressure (All Metal) Thru-Flow
Indicator Models 3604 and 3609**

January, 1981 (Supersedes issue dated May '80)

Description

The Hi-Pressure flow rate indicator is a rugged, yet inexpensive flow meter for flow rate indication at elevated pressures. Flow rate is measured by the movement of a metering plug, or float in a fixed orifice. Indication is provided by means of magnetic coupling in the float, which in turn affects another magnet in the rear of the indicator, transferring flow rate to the dial indicator mounted on the front of the metal tube.

Design Features

Mounts directly in vertical line
Non-rotating guided float
NPT (Model 3604) or flanged (Model 3609) connections
Standard water scales in GPM or GPH
Weatherproof indicator case
No float extension below inlet

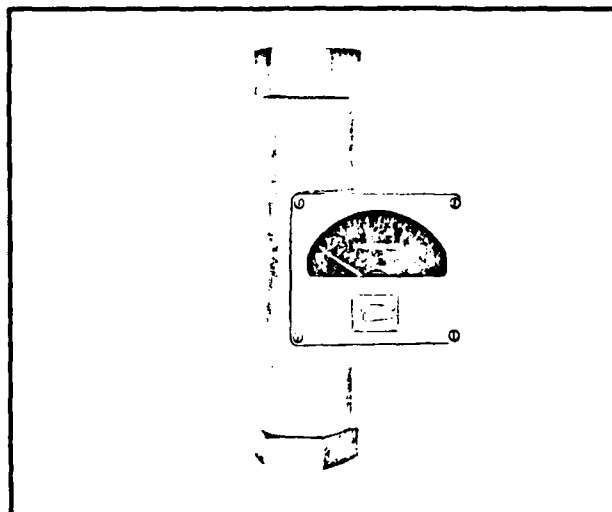

Model 3604D

Specifications

FLOWMETER WITH STANDARD INDICATOR

SCALES

Type: Direct reading or percent scale
Graduations: GPM or GPH water flow (Std.), Percent of maximum flow
Length: 4" nominal

RATINGS

Max. Pressure: Threaded Meters - Up to 1500 psi at 400°F
Flanged Meters - Determined by rating of flanges used.

PERFORMANCE

Accuracy: Industrial accuracy - $\pm 5\%$ of full scale. Calibrated accuracy: $\pm 3\%$ of full scale.
Repeatability: $\pm 1\%$ full scale

Materials of Construction

TUBE: 316 Stainless Steel
FLOAT: 316 Stainless Steel
METERING ORIFICE: 316 Stainless Steel
INDICATOR CASE: Cast Aluminum
ALARM HOUSING: Aluminum, Non-weatherproof
O-RINGS: Viton*

Capacities

Meter Size	Conn. Size (Note 1)	Flow Rate - Water		Flow Rate - Air (Note 2)		Press. Drop (PSI)
		Min.	Max.	Min.	Max.	
8	½"	1.5 gph	15 gph	6.0 scfh	60 scfh	5.0
		3.0 gph	30 gph	12.0 scfh	120 scfh	5.0
		5.0 gph	50 gph	20.0 scfh	200 scfh	4.5
		10.0 gph	100 gph	40.0 scfh	400 scfh	4.5
		18.0 gph	180 gph	1.2 scfm	12 scfm	4.5
		30.0 gph	300 gph	2.0 scfm	20 scfm	4.5
10	1"	1 gpm	5 gpm	Note 3		1.5
		1 gpm	10 gpm			1.5
		1 gpm	15 gpm			1.5
12	1½"	5 gpm	30 gpm	Note 3		3.0
		10 gpm	50 gpm			3.5
13	2"	10 gpm	80 gpm	Note 3		4.0
		10 gpm	100 gpm			4.5

Notes: 1. Available flange ratings: 150 lbs., 300 lbs., 600 lbs.
2. 1/2 inch size requires minimum 50 psig operating pressure for gas service.
3. Not recommended for gas flow.

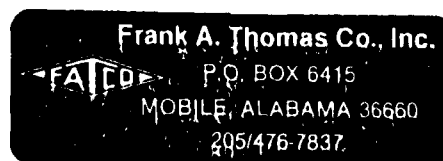

BROOKS INSTRUMENT DIVISION EMERSON ELECTRIC CO. HATFIELD, PENNSYLVANIA 19340

TELEPHONE: (215) 362-3500 TELEEX: 8461P

Optional Equipment

Alarm Switches – Single or Dual. One millisecond make and break; Rhodium-plated contacts rated at 0.25 amperes 115 v ac resistive load.

Alarm Relays – SPDT, DPDT, TPDT. Relays must be mounted remotely.

Ordering Information

To order, please specify:
 Model no. and size flowmeter
 Flange material
 Fluid and flow range
 Temperature °F

Pressure (psig)
 Specific gravity, viscosity
 Optional: Alarm, no. of switches and number of relays

Dimensions (For certified dimension prints, write to factory.)

MODEL 3604D				MODEL 3609D							
Conn. Size	A	B	C	Conn. Size	D			E			3604D/ 3609D
					150 lb. Flange	300 lb. Flange	600 lb. Flange	150 lb. Flange	300 lb. Flange	600 lb. Flange	
1/2"	6-11/16"	1-1/16" hex	1-45/64"	1/2"	8-7/8"	8-15/16"	9-7/16"	2-1/2"	2-17/32"	2-25/32"	3-9/16"
1"	10-1/2"	2" hex	2-3/4"	1"	12-5/8"	13-3/8"	13-7/8"	3-13/16"	4-3/16"	4-7/16"	4-1/2"
1-1/2"	11-3/4"	2-1/2" hex	3-9/16"	1-1/2"	14-3/4"	15-3/8"	16-1/8"	5-1/16"	5-3/8"	5-11/16"	4-7/32"
2"	12-5/8"	3" hex	4"	2"	16-1/8"	16-3/4"	17-5/8"	5-3/4"	6-1/16"	6-7/16"	4-15/32"

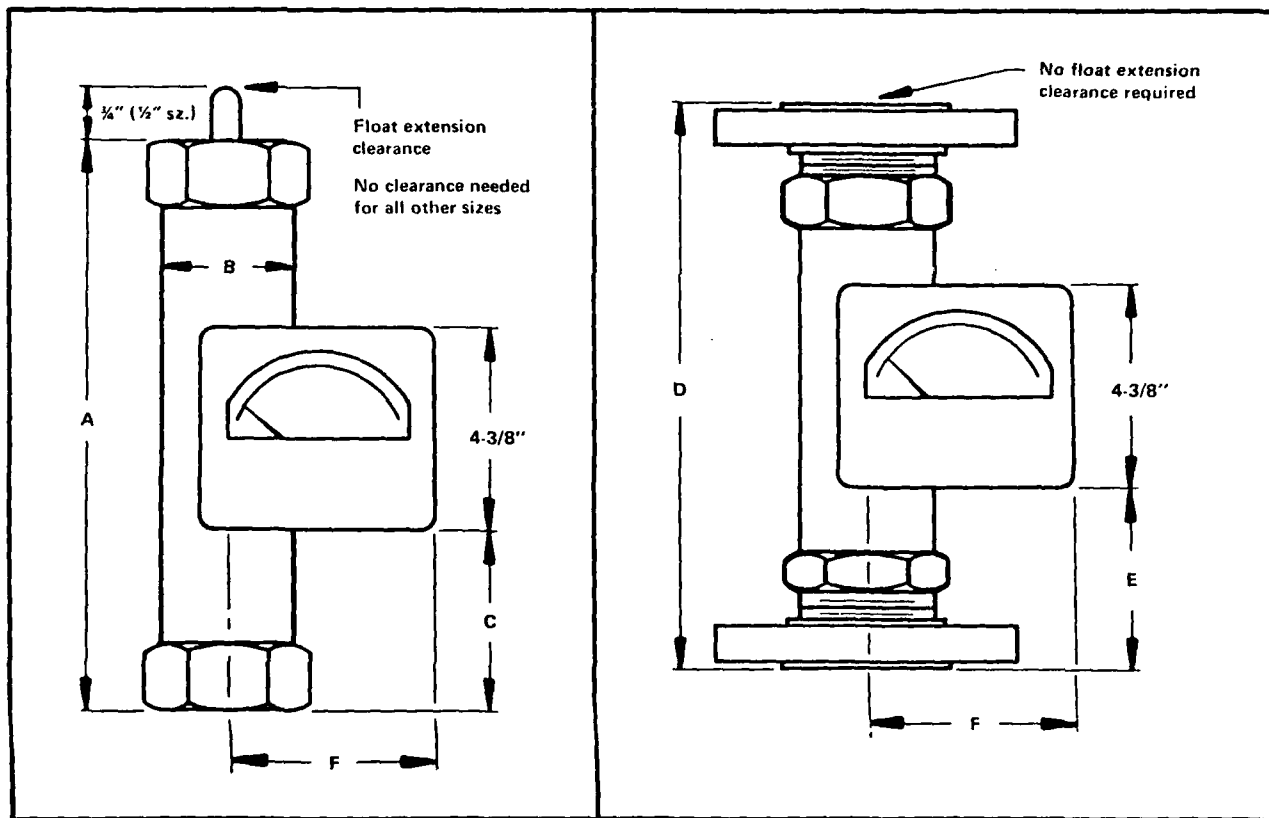

Model 3604D

Model 3609D

*TRADEMARK: E. I. DuPont de Nemours & Co.

Specifications subject to change without notice.

Printed in U.S.A.

Calibrated and correlated flowmeters . . .

high-precision, low-cost, easy-to-use meters

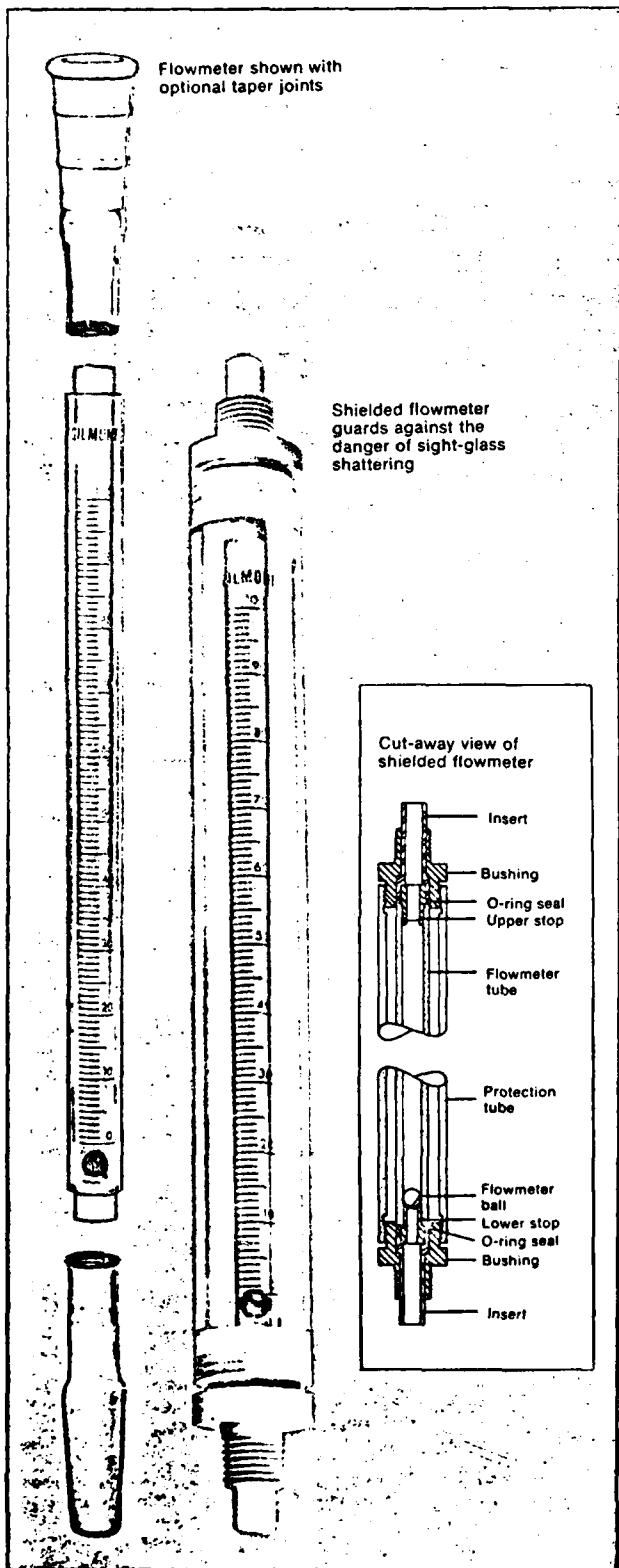

- **High precision**—Each flowmeter individually calibrated with air to establish physical constants of meter
- **Accuracy** is 2% of reading or 1 scale division, whichever is greater
- **Easy to read**—Permanent ceramic scale and white background make divisions stand out for easy reading
- **Calibration curve** for any fluid can be calculated if only the density and viscosity are known
- **No calculating needed for air or water flow**—Each serialized meter comes with its own calibration curve giving flows for air and water directly
- **Corrosive-resistant**—Fluid touches glass and Teflon*

Gilmont flowmeters are manufactured to extremely close tolerances to provide the greatest precision available for spherical float flowmeters. They are available in five sizes to cover the full range of flows normally encountered by spherical floats. The three smaller sizes are plain tapers, while the two larger sizes are beaded tubes to give stability where needed.

A new theory of correlation based on a dimensionless combination of Stokes law and flow coefficients makes it simple to calculate the calibration of any fluid with high precision; only the density and viscosity of the fluid at the conditions of flow are required. Each meter comes with its own calibration curve with flows for air and water. Because each meter is individually calibrated and plotted with co-ordinates to convert the curve to a straight line, highest precision is possible at a reasonable price.

Specially designed Teflon stops allow standard taper joints with precision-bore ends to be attached to the meter (joints not included, sold separately in table below). O-ring seals make this connection vacuum-tight. Taper joints can be purchased at any time and added to the plain tube ends of the meter. The assembly is easy to disassemble for cleaning.

Size no.	Flowmeters, plain ends				Set of joints*			
	Ranges, ml/min		Cat. no.	Price	S/T no.	Cat. no.	Price	
	Air	Water						
1	1-260	0.01-5.2	3201	\$52.00	10/30	3211	\$18.25	
2	10-1,900	0.2-38	3202	55.00	12/30	3212	18.50	
3	200-12,000	3-290	3203	54.00	14/35	3213	18.50	
4	1,000-36,000	10-850	3204	59.00	19/38	3214	20.50	
5	3,000-77,000	30-1,900	3205	64.00	24/40	3215	22.00	

*Consists of one inner joint and one outer joint plus two O-rings

Shielded flowmeters

Calibrated and correlated flowmeters with plastic shields to guard against the danger of sight-glass shattering

Shielded flowmeters combine the accuracy of the flowmeters above with the safety of a tough plastic outer protection tube. The tube is made of annealed cellulose acetate butyrate plastic with excellent optical properties for clear visibility of the meter. End bushings are corrosion-resistant polypropylene with Teflon* inserts. The bushings have standard male pipe threads; the inserts will also accept flexible hose. As in the flowmeters above, the fluid comes in contact only with glass and Teflon; it does not touch the protection tube or bushings. Shielded flowmeter sizes 1, 2, and 3 are 10" long x 1" diameter with 1/4" pipe threads; flowmeter sizes 4 and 5 are 12 1/2" long x 1 1/2" diameter with 1/2" pipe threads. Shields may be ordered separately and added to the flowmeter at any time.

Size no.	Shielded flowmeter complete			Shield only*	
	Maximum safe working pressures	Catalog number	Price	Catalog number	Price
1	500 psi	3201-20	\$ 82.25	3221-20	\$30.50
2	400 psi	3202-20	84.75	3222-20	30.50
3	350 psi	3203-20	86.00	3223-20	31.50
4	300 psi	3204-20	101.00	3224-20	45.75
5	250 psi	3205-20	103.00	3225-20	45.50

*Consists of outer tube with 2 bushings, 2 inserts and 2 O-rings

Note: See flowmeter kits on page 121

Teflon—Reg TM E I. DuPont de Nemours & Co

CATALOG NO. 500G

Hastings Mass Flow Instruments

for precision measurement & control
of gas flow

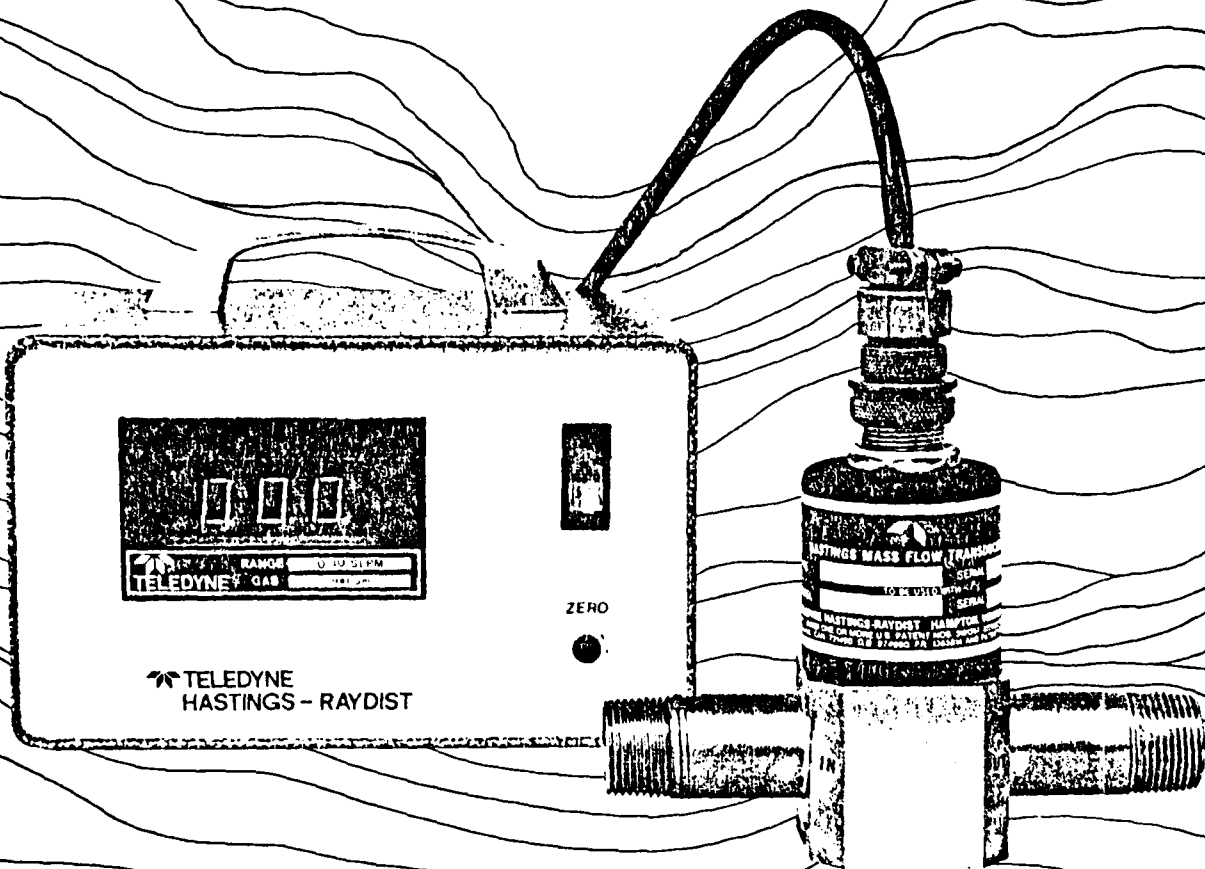

 **TELEDYNE
HASTINGS-RAYDIST**

Linear Mass Flowmeters

for mass flow measurements of gases

features

- Direct reading of mass flow
- No correction for temperature or pressure
- Simple multiplier available for most gases
- Inherently linear signal
- High accuracy, excellent repeatability
- Low pressure drop
- Rugged transducer with no moving parts
- Not damaged by over-ranging
- Sensitivity starts at zero

specifications

POWER: 115 volt a-c, 50/60 hz - 15 watt.
For 230 volt a-c, 50/60 hz - 15 watt, add prefix "E" to model number

CABLES: 8 ft. power and transducer cables supplied. Longer cables for transducers to 100 ft. optional at time of order.

OUTPUT: 0.5 volts d-c into a load of 2,000 ohms or greater. The signal is available at binding posts along with readout indication, 4-20 ma. optional.

ACCURACY: $\pm 1\%$ of range for 20% variation in pressure and temperature.
 $\pm 2\%$ of range over entire pressure and temperature ratings.

LINEARITY: $\pm 1/2\%$ of range

REPEATABILITY: $1/2\%$ of range

PRESSURE: 0.1 psia to 250 psig; higher pressure rated transducers available.

PRESSURE DROP: At atmospheric pressure, less than 6 inches of water at full scale flow for all ranges except 0-10 sccm, which is 10" H₂O.

TEMPERATURE: Gas temperature up to 100°C. Ambient for transducer and indicator, 0 - 40°C.

CALIBRATION: Direct reading is for air. Calibration available at time of order for oxygen, nitrogen, hydrogen, and carbon monoxide. Other gases at extra cost.

RESPONSE TIME: 7 seconds to 67% of reading

MATERIAL OF CONSTRUCTION:

BRASS TRANSDUCER: Brass base, constantan sensing tubes, glass seals, and soft solder

MONEL/SS TRANSDUCER: Monel or 316 stainless steel base. Constantan sensing tubes, ceramic/nickel seals, and copper/silver/nickel braze

CABINET DIMENSIONS: 7.75" x 5.75" x 5.75"

NIM DIMENSIONS: 5.41" x 8.71" x 9.68"

WEIGHT: Approximately 6 pounds

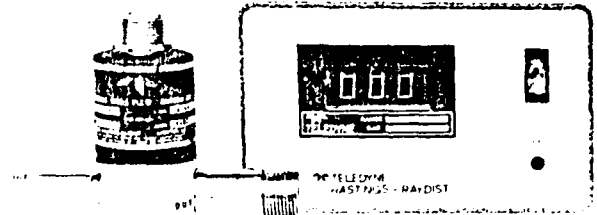

Transducer

Cabinet Model

description

Hastings Linear Mass Flowmeters operate on a unique electrical principle without corrections or compensations for temperature and pressure of the gas. The Flowmeters are ideal for use with totalizers and recorders due to the linear electrical signal.

Standard calibration is for AIR. Special calibrations are available for other gases or the gas multiplier listed on page 8 can be used.

Hastings Linear Mass Flowmeters do not require any periodic maintenance under normal operating conditions with clean gases. No damage will occur from the use of moderate overpressures, overflows, or liquid solvents.



NIM Panel Model

selection chart

Range	Cabinet Model	Panel Model	Transducer	
SCCM/ SLPM	115 volt	115 volt	Brass	Monel SS
0-5 sccm	NAHL-5	NAHL-5P	H-5	H-5MS
0-10 sccm	NAHL-10	NAHL-10P	H-10	H-10MS
0-50 sccm	NAHL-50	NAHL-50P	H-50	H-50MS
0-100 sccm	NAHL-100	NAHL-100P	H-100	H-100MS
0-500 sccm	NAHL-500	NAHL-500P	H-500	H-500MS
0-1 slpm	NAHL-1K	NAHL-1KP	H-1K	H-1KMS
0-5 slpm	NAHL-5K	NAHL-5KP	H-5K	H-5KMS
0-10 slpm	NAHL-10K	NAHL-10KP	H-10K	H-10KMS
0-50 slpm	NAHL-50K	NAHL-50KP	H-50K	H-50KMS

Range	Range	Cabinet Model	Panel Model	LFE and
SCFM	SLPM	115 volt	115 volt	transducer
0-5	0-150	NAHL-5	NAHL-5P	L-5 w H-3MS
0-10	0-300	NAHL-10	NAHL-10P	L-10 w H-3MS
0-25	0-750	NAHL-25	NAHL-25P	L-25 w H-3MS
0-50	0-1500	NAHL-50	NAHL-50P	L-50F w H-3MS
0-100	0-3000	NAHL-100	NAHL-100P	L-100F w H-3MS
0-200	0-6000	NAHL-200	NAHL-200P	L-200F w H-3MS
0-500	0-15,000	NAHL-500	NAHL-500P	L-500F w H-3MS

Laminar flow elements and transducer construction for all NAHL ranges are stainless steel monel.
For 230 volt, add prefix "E" to model number.