

AD-A105 618

PERCEPTRONICS INC WOODLAND HILLS CA

F/G 17/2

MAILPHONE: A DEMONSTRATION OF MAN-MACHINE-RELATIONS IN ELECTRON--ETC(U)

JUN 81 A MADNI, G WELTMAN

N00014-80-C-0755

UNCLASSIFIED

PFTR-1094-81-6

NL

1 of 2

AD
8105618

11

UNCLASSIFIED

LEVEL *(handwritten mark)*

AD A105618

MAILPHONE: A DEMONSTRATION OF MAN-MACHINE RELATIONS IN ELECTRONIC MAIL NETWORKING

Azad Madni
Gershon Weitman

DTIC
S OCT 14 1968 **D**
H

(Tilted rectangular stamp)

DTIC FILE COPY

Prepared for:
Office of Naval Research
MATHEMATICAL and INFORMATION SCIENCES DIVISION
800 North Quincy Street
Arlington, VA 22217

and

Defense Advanced Research Projects Agency
SYSTEM SCIENCE DIVISION, DEFENSE SCIENCES OFFICE
1400 Wilson Boulevard
Arlington, VA 22206

PERCEPTRONICS

8271 VAREL AVENUE • WOODLAND HILLS • CALIFORNIA 91367 • PHONE (818) 340-1000

81 10 14

The views and conclusions contained in this document are those of the authors and should not be interpreted as necessarily representing the official position, either expressed or implied, of the Government of the United States of America.

Approved for Public Release; Distribution Unlimited
Reproduction in whole or part is permitted for the Government of the United States of America.

12

14

15

PFTR-1094-81-6

Contract No. N00014-80-C-0755

June 1981

11

12/1061

6

MAILPHONE: A DEMONSTRATION OF MAN-MACHINE-RELATIONS IN ELECTRONIC MAIL NETWORKING.

10

Azad/Madni
Gershon/Weltman

DTIC
S E D
OCT 14 1981
H

Final report
80-Jul-81

Prepared for:

Office of Naval Research
MATHEMATICAL and INFORMATION SCIENCES DIVISION
800 North Quincy Street
Arlington, VA 22217

and

Defense Advanced Research Projects Agency
SYSTEM SCIENCE DIVISION, DEFENSE SCIENCES OFFICE
1400 Wilson Boulevard
Arlington, VA 22209

PERCEPTRONICS

6271 VARIEL AVENUE • WOODLAND HILLS • CALIFORNIA 91367 • PHONE (213) 884-7470

DISTRIBUTION STATEMENT A
Approved for public release;
Distribution Unlimited

2-10-81

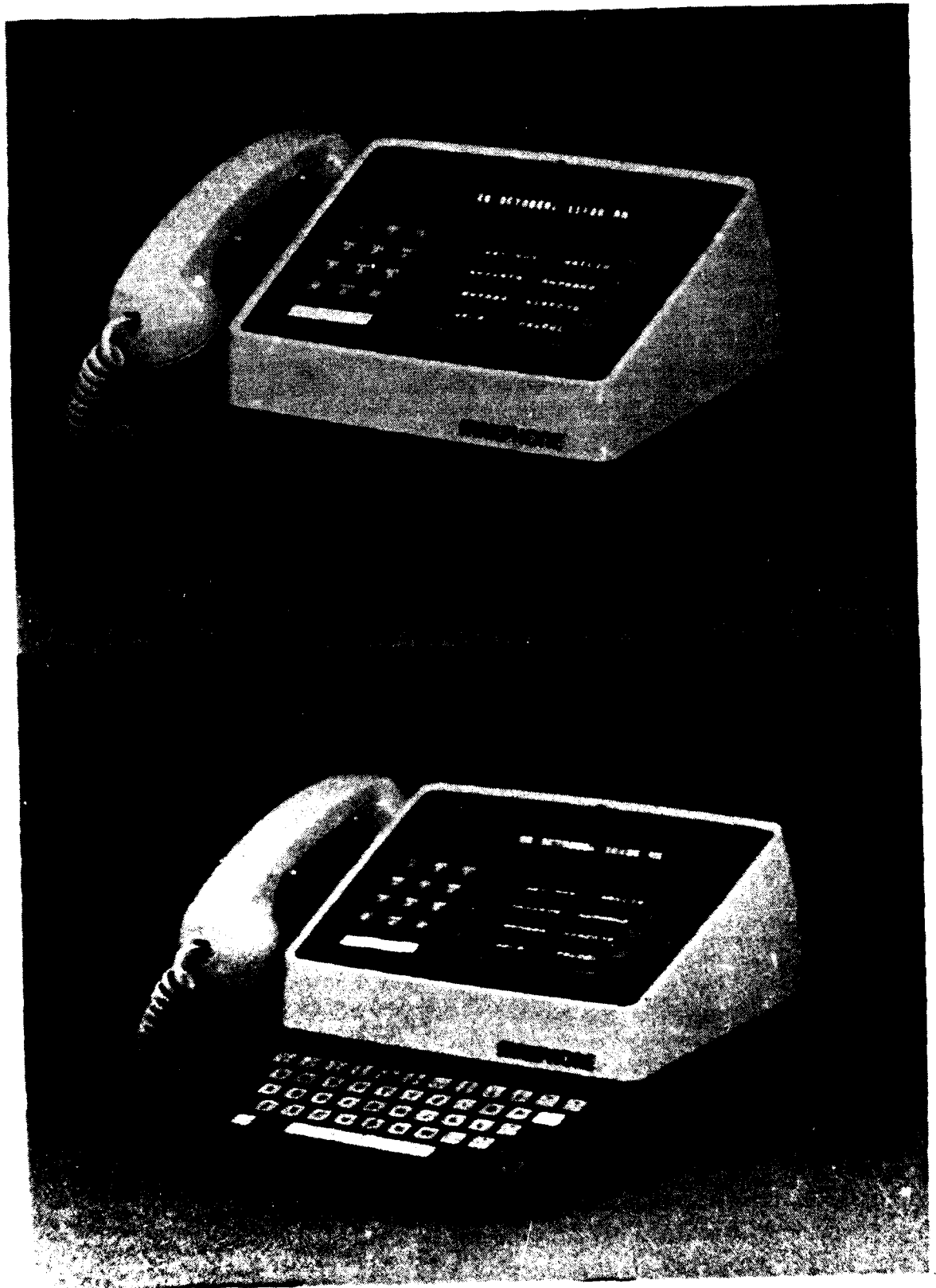

UNCLASSIFIED

SECURITY CLASSIFICATION OF THIS PAGE (When Data Entered)

| REPORT DOCUMENTATION PAGE | | READ INSTRUCTIONS BEFORE COMPLETING FORM |
|---|-------------------------------------|---|
| 1. REPORT NUMBER | 2. GOVT ACCESSION NO. AD-A105618 | 3. RECIPIENT'S CATALOG NUMBER |
| 4. TITLE (and Subtitle) MAILPHONE: A DEMONSTRATION OF MAN-MACHINE- RELATIONS IN ELECTRONIC MAIL NETWORKING | | 5. TYPE OF REPORT & PERIOD COVERED Final Technical Report July 1980 - June 1981 |
| 7. AUTHOR(s) Azad Madni, Gershon Weltman | | 6. PERFORMING ORG. REPORT NUMBER PFTR-1094-81-6 |
| 9. PERFORMING ORGANIZATION NAME AND ADDRESS PERCEPTRONICS, INC. 6271 Varie! Avenue Woodland Hills, CA 91367 | | 8. CONTRACT OR GRANT NUMBER(s) N00014-80-C-0755 ✓ |
| 11. CONTROLLING OFFICE NAME AND ADDRESS OFFICE OF NAVAL RESEARCH Department of the Navy 800 N. Quincy Street, Arlington, VA 22217 | | 10. PROGRAM ELEMENT, PROJECT, TASK AREA & WORK UNIT NUMBERS |
| 14. MONITORING AGENCY NAME & ADDRESS (if different from Controlling Office) Defense Advanced Research Projects Agency 1400 Wilson Boulevard Arlington, VA 22209 | | 12. REPORT DATE June 1981 |
| | | 13. NUMBER OF PAGES 103 |
| | | 15. SECURITY CLASS. (of this report) UNCLASSIFIED |
| 16. DISTRIBUTION STATEMENT (of this Report) UNCLASSIFIED: DISTRIBUTION UNLIMITED | | 15a. DECLASSIFICATION/DOWNGRADING SCHEDULE |
| 17. DISTRIBUTION STATEMENT (of the abstract entered in Block 20, if different from Report) SEE BOX SIXTEEN | | |
| 18. SUPPLEMENTARY NOTES | | |
| 19. KEY WORDS (Continue on reverse side if necessary and identify by block number) Variable Legend Function Keys Computer Communication Audio Messages Man-Machine Relations Executive Telephone Text Scrolling User-Interface Design Electronic Mail Online Directory Single Line Display Text Messages | | |
| 20. ABSTRACT (Continue on reverse side if necessary and identify by block number) This technical report covering a twelve-month period (July '80-June '81) describes the design of the MAILPHONE, a Man-Machine Relations (MMR) concept demonstration project in computer-based systems. The intent of this project is to show that new approaches to man-computer interface design can overcome serious problems associated with the underutilization of military computer systems. In the present project, the approach was to select a useful military computer system which was poorly designed from MMR viewpoint, redesign it with | | |

UNCLASSIFIED

SECURITY CLASSIFICATION OF THIS PAGE(When Data Entered)

20. Abstract (Cont'd)

careful emphasis in the key MMR areas, and document the improvements in acceptance and performance.

The military computer system selected for improvement was the ARPANET electronic mail system. The MMR improvements were realized by a complete redesign of the electronic mail interface, and demonstrated by the MAILPHONE, a microprocessor-based system featuring a desk top unit purposely designed to resemble the familiar telephone. The MAILPHONE, while complex technologically, is designed to be operationally both simple and friendly.

The report provides a detailed description of the MAILPHONE system concept, including the user interface, the MMR features, and hardware implementation. The software design at the functional level is also included.



UNCLASSIFIED

SECURITY CLASSIFICATION OF THIS PAGE(When Data Entered)

TABLE OF CONTENTS

| | <u>Page</u> |
|---|-------------|
| 1. INTRODUCTION | 1-1 |
| 1.1 Summary | 1-1 |
| 1.2 MMR Problem Analysis | 1-2 |
| 1.3 Computer System Selection | 1-7 |
| 1.4 System Concept | 1-8 |
| 1.5 MMR Improvements | 1-10 |
| 1.6 System Production and Evaluation | 1-11 |
| 2. MAILPHONE SYSTEM FUNCTIONS AND USER INITIATIVE | 2-1 |
| 2.1 Overview | 2-1 |
| 2.2 Functional Capabilities | 2-2 |
| 2.3 User Interface | 2-3 |
| 2.3.1 Prototype Desk Unit Fabrication | 2-3 |
| 2.3.2 Variable Legend Function Keys | 2-5 |
| 2.3.3 Single-Line Display | 2-7 |
| 2.3.4 Display Modes: Study and Selection | 2-7 |
| 2.3.5 Pull-Out Keyboard | 2-10 |
| 2.3.6 MAILPHONE Text Editor: Interface and Capabilities | 2-12 |
| 2.4 MAILPHONE Interface Functions | 2-14 |
| 2.4.1 SENDMAIL Function | 2-16 |
| 2.4.2 READMAIL Function | 2-18 |
| 2.4.3 DIRECTORY Function | 2-18 |
| 2.4.4 SET UP Function | 2-20 |
| 2.4.5 QUIKDIAL Function | 2-20 |
| 2.4.6 REDIAL Function | 2-20 |
| 2.4.7 STATUS Function | 2-24 |
| 2.4.8 HELP Function and System Prompts | 2-24 |
| 2.4.9 CANCEL Function | 2-25 |
| 3. PROTOTYPE SYSTEM DESIGN | 3-1 |
| 3.1 Desk Unit | 3-1 |
| 3.1.1 Alphanumeric Keyboard | 3-3 |
| 3.1.2 Keypad and Function Keys | 3-3 |
| 3.1.3 Displays | 3-6 |
| 3.1.4 Handset Switch | 3-6 |

| | |
|--------------------|-------------------------------------|
| Accession For | |
| NTIS GRA&I | <input checked="" type="checkbox"/> |
| DTIC TAB | <input type="checkbox"/> |
| Unannounced | <input type="checkbox"/> |
| Justification | |
| By _____ | |
| Distribution/ | |
| Availability Codes | |
| Dist | Special |
| A | |

TABLE OF CONTENTS (CONT'd)

| | <u>Page</u> |
|---|-------------|
| 3.2 Control Unit | 3-6 |
| 3.2.1 Microcomputer | 3-9 |
| 3.2.2 MODEM/Coupler | 3-10 |
| 3.2.3 Audio Switch | 3-12 |
| 3.2.4 Audio Cassette Recorder (ACR) | 3-17 |
| 3.2.5 Printer | 3-18 |
| 3.2.6 Power Supply | 3-18 |
| 3.2.7 100,000 Day Clock | 3-19 |
| 3.3 Control Unit-Desk Unit Interface | 3-19 |
| 4. PROTOTYPE SOFTWARE DESIGN | 4-1 |
| 4.1 Desk Unit Software | 4-1 |
| 4.2 Control Unit Software | 4-2 |
| 4.2.1 Function State Processing | 4-2 |
| 4.2.2 Interface Management | 4-5 |
| 4.2.2.1 100,000 Day Clock | 4-8 |
| 4.2.2.2 Audio Switch | 4-8 |
| 4.2.2.3 Audio Cassette Recorder (ACR) | 4-8 |
| 4.2.2.4 MODEM | 4-9 |
| 4.2.2.5 Coupler | 4-9 |
| 4.2.2.6 Printer | 4-9 |
| 4.2.2.7 Disk | 4-9 |
| 4.2.3 Service Functions | 4-10 |
| 4.2.4 Data Bases | 4-11 |
| 4.2.4.1 Directory | 4-11 |
| 4.2.4.2 SENDMAIL Header Buffer | 4-11 |
| 4.2.4.3 Text Generation Buffer | 4-13 |
| 4.2.4.4 READMAIL Header Buffer | 4-14 |
| 4.2.4.5 Text Transmission and Receiving Buffer | 4-14 |
| 4.2.5 MAILPHONE To MAILPHONE Message Protocol | 4-14 |
| 5. SUMMARY | 5-1 |
| 6. REFERENCES | 6-1 |
| APPENDIX A - MAILPHONE DESK UNIT/CONTROL UNIT INTERFACE DESIGN AND PROTOCOL | A-1 |
| APPENDIX B - DATA SHEETS FOR 100,000 DAY CLOCK, AUDIO CASSETTE RECORDER, MODEM, POWER SUPPLY | B-1 |

1. INTRODUCTION

1.1 Summary

This final technical report covering a twelve-month period (July '80 - June '81) is submitted in response to the requirements of Contract No. N00014-80-C-0755, the MAILPHONE project. The MAILPHONE is a demonstration project in "man-machine-relations (MMR)." The intent of this project is to show that new approaches to man-computer interface design can overcome certain serious problems associated with the under-utilization of military computer systems. In the present project, the approach was to select a useful military computer system which was poorly designed from MMR viewpoint, re-design it with careful emphasis in the key MMR areas, and document the improvements in acceptance and performance.

The military computer system selected for improvement was the ARPANET electronic mail system. The MMR improvements were realized by a complete re-design of the electronic mail interface, and demonstrated by the MAILPHONE, a microprocessor-based system featuring a desk top unit purposely designed to resemble the familiar telephone. The MAILPHONE, while complex technologically, is designed to be operationally both simple and friendly. Three desk units have been fabricated, and two complete prototype systems have been developed and successfully demonstrated at DARPA. These systems will be evaluated empirically in terms of acceptability, personality, and performance.

Subsequent sections of this report provide a detailed description of the MAILPHONE system design. Section 2 covers the system functions and the user interface. The prototype hardware design is presented in Section 3. The prototype software design is described at the functional level in Section 4.

1.2 MMR Problem Analysis

Despite the proliferation of computers in civilian and military organizations, acceptance and exploitation of the machines by their intended users is still far from optimum. Numerous examples exist of computer systems which are designed to high expectations, but which are in essence rejected by their user populations, and which consequently remain under-utilized and ineffective through their costly life.

The problem areas which underlie acceptance and rejection appear to go beyond the usual "human factors" concerns of legibility, control/display design, accessibility, and the like, and even beyond the actual utility of the system. Rather, they resemble in some ways the social issues surrounding race relations among people. That is, the users act as if the computers were an "alien race" introduced into their midst. They form likes and dislikes on the basis of factors which affect them in a highly personal manner. These factors rest partly on past prejudice early in the contact. Once established, they are later modified with great difficulty, if at all. One may hypothesize several underlying reasons for poor relations between man and machine. The root may be cultural. That is, many people may harbor a basic mistrust of computers. In fact, a nationwide survey found that 54% of the respondents believe that computers are dehumanizing, 47% feel that computers often make mistakes, and 33% feel that computers will decrease our freedom.

Another cause may be the lack of specialization associated with computers. Since the general purpose computer cannot be identified with any single functions, some people may misunderstand its use and application potential. In other words, when a computer or terminal is presented to them, these people may resent that it was not specially designed and customized with a specific function intention in mind (namely, their own).

Finally, the nature of a user's background may impact upon his attitudes toward computers. For example, Freedy, Weltman, and Lyman (1972) found such an effect among subjects who interacted with a computer model which was learning the appropriate strategy to employ in a path-following task. Those with a technical background tended to eagerly await the point at which the computer had adapted sufficiently to begin making recommendations, while those with a nontechnical background tended to regard the computer as an interference.

In any case, it is possible to identify some specific areas of concern in man-computer-relations; these include:

- (1) Lack of confidence, reflecting perceived unreliability, often resulting from failures, errors, or breakdowns in the sensitive early stages of system introduction.
- (2) Divergence from perceived function, where the hardware or software manifestation of the system is at odds with the user's idea of what it does or should do.
- (3) Divergence from individual needs, where the user feels that his specific requirements, preferences, tastes, etc., are ignored or even offended by specific system characteristics.
- (4) Divergence from individuality, where the user feels that he is unable to influence the system personally.
- (5) Threat to privacy, where the user feels he or she is liable to some form of exposure (data or decisions) as a result of system utilization.

- (6) Threat to security or self-esteem. Of particular importance to acceptance, this often reflects the reluctance of well-placed users to make themselves look foolish by failing to master a seemingly complex new technology. It may also reflect a personal conclusion that one's job is vulnerable to computer encroachment; or, alternatively, that computer utilization diminishes the status of that job by incorporating menial elements.

Table 1-1, which summarizes the results of a study relating reasons for resistance to management computer systems to job level, is an interesting addition to these points. As seen, resistance rests on a broad range of reasons. But at the top management level, which is not only the final decision making level, but which also sets the tone for an organization, resistance is based largely on feelings of unfamiliarity, insecurity, and ambiguity. This type of feelings are most likely associated with computer systems as a class, rather than with a specific system under consideration. Accordingly, MMR problems of this nature are frequently not as obvious to system designers as are those centering around system performance, such as processing capabilities, data handling capacity, response speed, etc.

However, since a system which is rejected a priori cannot begin to fulfill its performance objectives, it is evident that improved MMR's should have a highly significant effect on improving total system effectiveness. What is required is an established set of MMR design principles, easily understood and applied, which will guide computer system designers in specific design situations. The proposed project is a significant step toward the application of MMR design to military computer systems.

TABLE 1-1

REASONS FOR RESISTANCE TO MIS BY WORK GROUPS. (Adapted from G.W. Dickson and John K. Simmons, "The Behavioral Side of MIS," Business Horizons, August 1970, p. 68.)

| | Operating (nonclerical) | Operating (clerical) | Operating Management | Top Management |
|--|----------------------------|-------------------------|-------------------------|-------------------|
| Threats to economic security | | X | X | |
| Threats to status or power | | X | X | |
| Increased job complexity | X | | X | X |
| Uncertainty or unfamiliarity | X | X | X | X |
| Changed interpersonal relations or work patterns | | X | X | |
| Changed superior-subordinate relationships | | X | X | |
| Increased rigidity or time pressure | X | X | X | |
| Role ambiguity | | X | X | X |
| Feelings of insecurity | | X | X | X |

Major MMR Factors. Preliminary analysis of MRR in computer systems identified six major areas of concern; these are:

- (1) Configuration or Form: The physical aspects of the system, particularly as they relate to its integration into the user's work environment.
- (2) Personalization: All system features which make it responsive to individual needs and preferences, and which promote a feeling of individual attachment to it.
- (3) Interface Functions: Those features which affect actual user contact with the system-- predominantly concerned with the modes and forms of information exchange between system and user.
- (4) Subsidiary Incentives: Extra features provided by the system, beyond its primary function, which increase its attractiveness and promote familiarization and practice.
- (5) Indoctrination: The philosophy, methodology, content, and circumstances of the user's introduction to the system, including descriptions of its purpose, its function, its underlying technology, its unique characteristics, and its potential job implications.
- (6) Instruction: The means by which the user learns to operate the system. Of particular interest is embedded instruction, in which the system itself provides the instructional media.

Other factors, such as social and organizational context of use, may also affect MMR. But both in this study, which is directed toward an existing system, and also in general system development, such factors tend to be out of the designer's control, and so are of lesser practical importance.

1.3 Computer System Selection

The system selected for improvement was the ARPANET electronic mail system. The ARPANET is a network of interconnected computers and terminals which currently serves 2,200 DOD or DOD-connected individuals, many of whom act as contact points for entire organizations. In addition to tremendous computing resources, ARPANET users have available one of several electronic mail services. These services provide the capability for composing messages at a terminal and for routing them to the incoming mail files of other ARPANET users. Since the ARPANET was not originally designed for communication, or for non-technical users, it lacks effective MMR. The result is suboptimum use of this resource. The main reasons for selecting the ARPANET are that:

- (1) It is an existing system, i.e., it is already installed, operating, and has a performance history.
- (2) Its usage is job related, i.e., contributes in a real way to the user's job.
- (3) Its usage is voluntary, i.e., functions can be accomplished manually by the user if desired; this presumes a middle management or upper management user.
- (4) It is unclassified.
- (5) It is suboptimally designed from an MMR viewpoint, i.e., attitudinal problems currently exist; these seem to affect performance with system.
- (6) It is accessible in the sense that it is possible to perform experimental manipulations, i.e., to modify user interface and to obtain performance measurements.

In addition, selecting a system dedicated to communication and information distribution was considered desirable for three main reasons. First, communication systems generally involve continuous close contact between man and machine, thus they are likely to aggravate adverse MMR. Second, such systems are of growing importance to the military at all levels of organization, from squads to the Office of the Chief of Staff. Finally, communications systems have been previously examined in psychological contexts closely related to MMR, so that there is a body of empirical data to aid in the planning of our proposed study and the interpretation of its results.

1.4 System Concept

The MAILPHONE system proposed for electronic mail handling is designed to address directly those problems existing in current electronic mail systems such as the ARPANET and also to incorporate positive MMR factors as outlined in Section 1.2. The Perceptronics MAILPHONE is a complete redesign of the electronic mail interface. Physically, this microprocessor-based, stand-alone system consists of two units; the Desktop Unit and the Control Unit. The MAILPHONE Desk Unit (shown in Figure 1-1) is purposely designed to resemble an extension of the familiar telephone rather than a version of the more controversial computer terminal. The MAILPHONE has all of the capabilities and characteristics of an executive telephone, in addition to its electronic mail functions. Inset into the MAILPHONE Desk Unit is a 40-character LED display, on which the user can view or compose messages. Message composition is done via a flat keyboard, approximately the shape and dimensions of a small pad of paper. When not in use the keyboard slides neatly under the Desk Unit.

A key feature of the interface is the LED displays associated with the eight special-function keys. These displays are under software control, so that the legends associated with the function keys change depending on which top-level function is evoked. This provides for great flexibility of operation without confusion to the user.

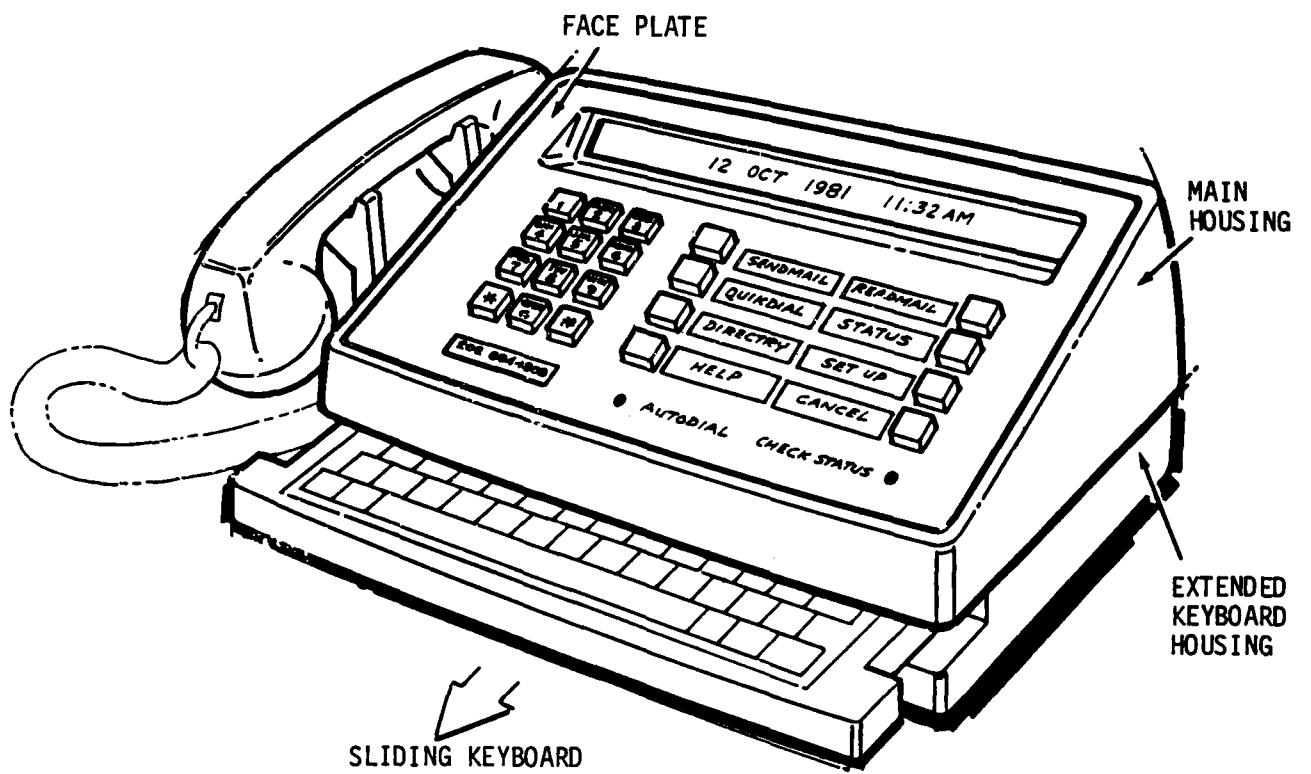

FIGURE 1-1.
MAILPHONE DESK UNIT

A single cable connects the MAILPHONE Desk Unit to its Control Unit, which is located in some convenient nearby place. This cable houses both the standard audio and RS-232 connections. The Control Unit is a microcomputer with a limited amount of local storage. When the MAILPHONE is used as a telephone, the Control Unit is a channel for regular telephone service. However, when used to access electronic mail services or other MAILPHONE features, the Control Unit also provides the following functions:

- (1) Automatic connection to other MAILPHONES.
- (2) Local interface personalization by the user.
- (3) Auxiliary services such as alerting, autodial, text and audio message editing, etc.
- (4) Reference information on MAILPHONE use.
- (5) Printer control and message formatting.

Mail service and other auxiliary services are all located within the microprocessor control unit. The MAILPHONE, like the telephone, is always available to the user, in contrast to remote ARPANET computers or network interfaces which may often be unavailable due to hardware or communication problems. Hardcopy of electronic mail messages are provided by a small printer also controlled by the microcomputer.

1.5 MMR Improvements

The overall goal of this project was to produce a system which is highly desirable to the user-- in essence, instantly attractive. The approach was to make it simultaneously modern, friendly and transparently convenient and helpful. Individual improvement categories include:

- (1) Form. Specialized industrial design provides details of shape and finish which accentuates the "advanced telephone" nature of the unit, while incorporating such features as quality, substantiality, utility and unobtrusiveness.

- (2) Personalization. Users have several options for physical and functional personalization of the MAILPHONE: these options focus on promoting attitudes of ownership and security. Future emphasis will be on adjusting the "personality" of the interactive software for compatibility with the user's preference.
- (3) Interface Functions. Obnoxious traits of the present ARPANET interface have been eliminated, and new interactive functions have been provided to give the interface a simpler and friendlier character. This includes relieving of the user of "overhead" operations in sending and receiving messages, providing clear indications of what has occurred, and what to do in the case of errors, and presenting the message information in well-formatted and quickly assimilable forms.
- (4) Instruction. The MAILPHONE offers embedded instruction in the form of system prompts in response to HELP function key usage.

1.6 System Production and Evaluation

The design and prototype production of the MAILPHONE Desk Units was sub-contracted to S.G. Hauser and Associates, Inc. of Woodland Hills, California. This company has had previous experience with telephone system designs. The design program proposed by S.G. Hauser included a very accurate layout developed by SGH and based on the hardware specified by Perceptronics. Rough sketches were done based on this layout and a dimensional model was fabricated by SGH. This "soft" mockup (i.e., non-working model) was used to determine Desk Unit configuration and volume, and representative final appearance.

After approval of the model and general approach, SGH generated a final drawing and package layout of the housing parts. They also supervised the fabrication of the short-run molds; in this case they were fiberglass since only three units were made. SGH were responsible for providing Perceptronics with three completed prototype Desk Units. They supervised the fabrication of the housing as well as the mounting of the Desk Unit electronics. The demonstration MAILPHONE units resemble production systems as closely as possible in look, feel, and function, but are actually assembled from commercial and custom components using prototype and small-run techniques.

The MAILPHONE system will eventually be evaluated by a selected sample of ARPANET users. The user group will be selected on the basis of having a job-related communications need, and a potential for improved communication effectiveness.

2. MAILPHONE SYSTEM FUNCTIONS AND USER INTERFACE

2.1 Overview

Prior to going into the details of the MAILPHONE user interface and system design, it is important to recognize that the MAILPHONE is being designed for the casual user. J. Martin (1973) describes the casual user or operator as one who uses the terminal only occasionally, spending most of the day doing something different. Such users have little, if any, training in terminal usage. For them,

"the man-machine interface must be designed to appear as natural as possible or [their] bewilderment will quickly turn into annoyance, criticism, or behavior that amounts to rejection of the system."

The main characteristics of the casual user can be summarized under three main categories:

- (1) Consequences of Infrequent Use. The casual user forgets much more than does the dedicated user, and hence is very prone to error if allowed free input. It is, therefore, better to offer him a "constrained choice" interface which exposes a relatively small number of items to consider at any one time, and implicitly or explicitly guide the user to a solution. It has been found that users tend to forget details taught during their initial training (if any) which are not regularly reinforced during normal system use. Such training should therefore be restricted to covering the main operational concepts, and on-line help should be readily available from the system itself. Casual users often would like to specify their needs vaguely, using the system's output

to understand their own requirements better and to build confidence. Their typing ability, especially with non-alphabetic characters, is usually poor.

- (2) Need for a "Natural"-Feeling System. In general, a casual user resents being forced to construct syntactically formal and precise queries. He prefers to think of data in more real-world terms than those of system objects and names. An ideal system should not be legalistic about interpreting the intent of an actual query. A courteous, coherent and rational dialogue flow is important, using terms the user can understand, while maintaining a conversational context.
- (3) Limited Mathematical and Programming Skills. Such users are unlikely to pose very complex queries, and therefore a "relationally complete" interface is not as vital as is often supposed. In particular, they tend to avoid logical operators for fear of misuse. Implicit logic is, therefore, preferable to explicit logic.

The foregoing discussion of the casual user provides the basis for the design of the MAILPHONE user interface. The remainder of this section is devoted to describing the required functional capabilities, the system concept, the user interface and the associated interface functions for electronic mail handling, normal phone call and subsidiary incentives.

2.2 Functional Capabilities

Since the MAILPHONE is a complete redesign of the electronic mail interface, its primary function is to provide electronic mail handling functions. To this end, the MAILPHONE can transmit or receive text or prerecorded spoken messages to and from other MAILPHONES. Included in

the text message transmission process are message composition, modification deletion, display, and alert capabilities. Included in text message reception are automatic recognition, answer, storage, display and alerting capabilities. The MAILPHONE also serves as an executive telephone. In addition to manual telephone dialing, the MAILPHONE provides speed-dialing and auto-redial capabilities. The prototype system offers some personalization features such as user-selectable date-time display, text display rates and hardcopy options.

2.3 User Interface

The MAILPHONE user interface is the Desk Unit. It consists of the normal telephone interface (keypad and handset), a set of 'soft' (variable legend) function keys, a pullout keyboard, a single line display and two LED indicators. The variable legend function keys are used to invoke executive phone and electronic mail handling functions. The pullout keyboard is used for text message composition and on-line directory update. The single-line readout is used for text display during message composition, transmission, viewing and reception. One of the two LED indicators is used for signaling when autodial is in progress. The other "lights up" when the system detects faulty conditions (e.g., cassette tape not positioned properly) that prevent normal system operation.

2.3.1 Prototype Desk Unit Fabrication. The Desk Unit is constructed around the standard Multi-button Desk Telephone housing assembly (model 2830-60-11). The front panel or face plate is designed to accommodate the MAILPHONE user interfaces along with the standard touchtone keypad purchased from Grayhill, Inc. The base of the unit, which extends downward, houses the retractable keyboard. Refer to Figure 1-1 for a pictorial view of

The Desk Unit. The Desk Unit also houses the various electronic components that make this unit an intelligent interface device. The industrial design and assembly of these parts was performed by S.G. Hauser and Associates. The following subsections give fabrication details in each of the above mentioned areas.

Face Plate. The face plate is designed and fabricated from Acrylonitrile-Butadiene-styrene (ABS) copolymer molding compound identical to the main Desk Unit housing assembly. The dark brown face plate is color-coordinated to match the beige main housing. The face plate is fabricated from a single piece of ABS material with cutouts for the 12 touchtone keypad switches, the eight function switches (both purchased through Grayhill, Inc.) and the AUTODIAL and CHECK STATUS L.E.D.'s. Additionally, the cutouts for the 8 legend displays and the 40 character displays are provided with contrast filters (Panel-Graphic Gray 10) for improved viewing of the amber displays as well as providing a "dead front" effect when the displays are unlit.

Keyboard. The keyboard base plate is made from ABS with the outer rim painted to match the face plate. The keyboard assembly consists of the keyboard, the graphics overlay, the keyboard base plate and a sliding mechanism that allows the keyboard to smoothly slide in and out of the base housing. When not in use, the keyboard remains out of sight within the base housing of the Desk Unit. The sliding mechanism, fabricated from cold rolled steel, plated in clear cadmium (rust proof), houses two black Delrin movement guides. When out, the keyboard can be set at a slight tilt to facilitate simultaneous typing and viewing. The keys, mounted on a small ABS plate, are based on membrane-switch keyboard technology.

Electronics. Three printed circuit boards (PCB) contain all Desk Unit electronic components. These PCB's are custom-designed to fit within the Desk Unit housing as shown in Figure 2-1. These cards are electronically interconnected through the use of flexible, flat ribbon cables with standard connectors.

The first board attaches directly to the face plate. The standard touchtone keypad, the 8 function switches and associated legends and the two L.E.D.'s are mounted on this PCB along with the associated drive and interface electronics components.

The second PCB contains the 40 character displays, the 8085 microprocessor and memory IC's and associated interface electronic packages. The speaker and Control Unit interface electronic IC's are mounted on the third PCB. This circuit card is mounted directly to the rear of the main housing. The Control Unit interconnect cable, attached to this card, connects to the serial interface from the main computer via a hole cut in the back of the Desk Unit enclosure (see Figure 2-1).

2.3.2 Variable Legend Function Keys. There are eight function keys each with an associated 8-character L.E.D. readout that provides the variable legend capability. The eight readouts under software control display the appropriate self-explanatory legend for each of the eight keys based on which top-level function was selected by the user. The main advantage of the variable legend function keys is that they provide great flexibility of operation without confusion to the user. HELP and CANCEL legends are always associated with the two bottom-most keys. The purpose of the HELP key is to provide on-line assistance to the user rather than force the user to refer to manuals or other forms of off-line documentation that detract from the conversational nature of the interaction system.

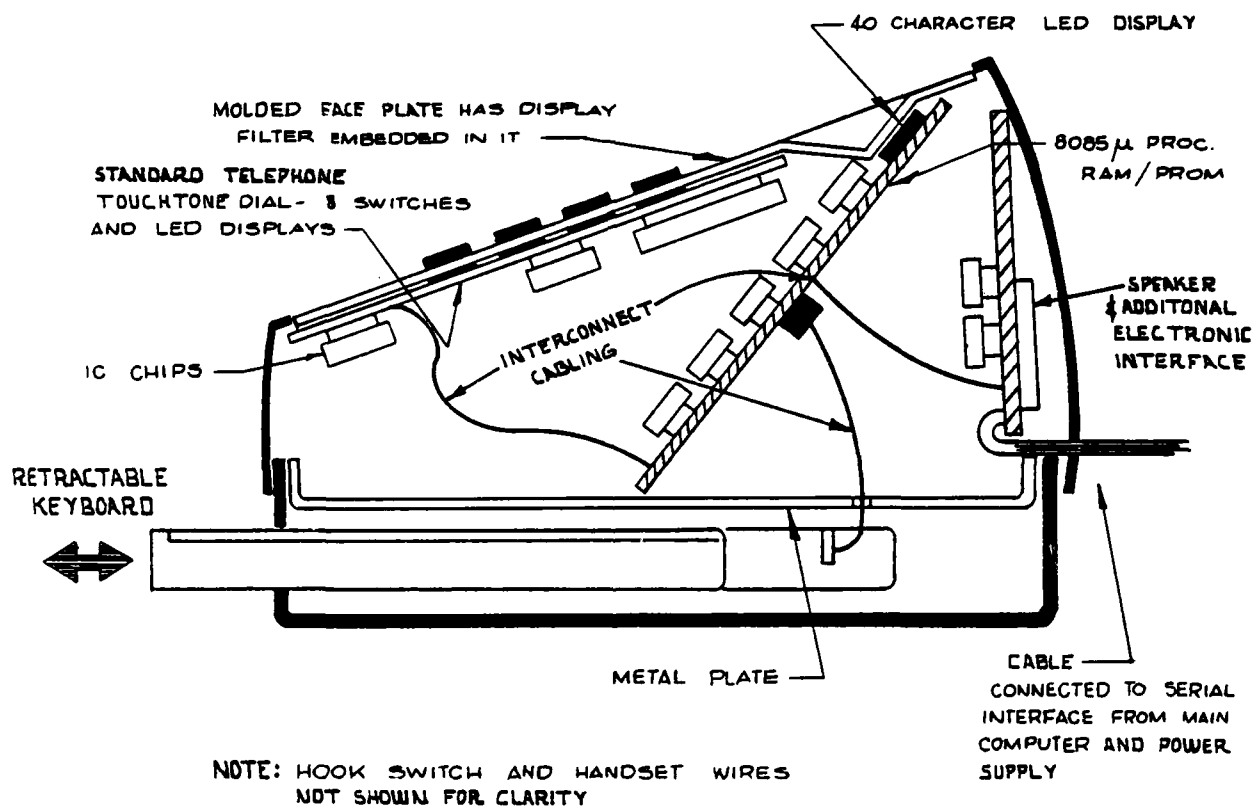

FIGURE 2-1.
DESK UNIT PHYSICAL LAYOUT

The purpose of the CANCEL key is to abort any MAILPHONE operation in progress and restore the QUIESCENT state menu.

2.3.3 Single-Line Display. A single-line 40-character alphanumeric yellow L.E.D. display (Hewlett-Packard HDSP-2001) is used to read and compose electronic mail. The 8-inch display is inset into the MAILPHONE at an angle suited to comfortable viewing. The yellow L.E.D.'s were selected on the basis of being least fatiguing to the eye. The HDSP-2001 display is a .15-inch 5X7 yellow L.E.D. array that is available in 4-character clusters. The HDSP-2001 has an integral untinted glass lens. The MAILPHONE employs the PANELGRAPHIC Gray 10 front panel contrast filter recommended for use with the HDSP-2001.

2.3.4 Display Modes: Study and Selection. Two distinct display modes are feasible for presenting textual information on the MAILPHONE 40-character single-line display. The first is "Saccadic Scrolling" in which the display is scrolled vertically, i.e., as if one were reading a newspaper column one line at a time. In Saccadic Scrolling, an entire line remains on the display for a certain period of time, and is then replaced instantaneously by a different one in the same location. The resulting effect is that of new material appearing instantly in the visual field, much as it does during the fixation pauses between saccadic in normal reading. It is this feature that motivates the choice of the term "Saccadic Scrolling." Saccadic Scrolling can be performed automatically or manually. In the automatic mode, the text is advanced automatically at a pre-established uniform rate but can be adjusted during the course of reading by the user. In the manual mode, the text can be made to advance to the next line or return to the previous line via two control function keys: 'NEXT LINE' or 'PREVIOUS LINE.' In the manual mode, any change in the displayed material requires a specific key-press.

The second display mode is the conventional Times Square mode. In this mode, the text appears to flow from right to left, moving one character at a time, until the end of the passage. This is accomplished by re-writing the text with each character moved one position to the left, causing the left most character to disappear and a new character to appear from the right. The display rate in this mode can be made variable with the implementation of a 'FASTER' and 'SLOWER' key. Pressing one of these two keys causes an increment or decrement in the apparent speed (i.e., the frequency of rewriting the line with a character shift) of the text on the screen. An additional 'REVERSE' key causes the text to reverse direction and move from left to right, while pressing the 'ADVANCE' key causes the resumption of right to left motion.

The two display formats, i.e., the Saccadic Scrolling (vertical scrolling) and Times Square (horizontal scrolling) were evaluated in a reading performance (both speed and comprehension) experiment conducted at University of California, Santa Barbara (Sekey, 1980). The results of this experiment were that for reading speed, Saccadic Scrolling (both automatic and manual) was vastly superior to the Times Square mode (see Table 2-1). For comprehension, Saccadic Scrolling was once again superior to the Times Square mode. Manual Saccadic Scrolling mode was found to be superior to the automatic Saccadic Scrolling mode (see Table 2-2).

After analyzing the results of their experiments, the experimenters attributed the poor reading performance obtained by the Times Square mode to the conflicts that arise between letter movement and saccadic eye movement. Given the results of this study, Saccadic Scrolling was selected as the message viewing mode for the MAILPHONE.

TABLE 2-1

READING TIME (MINUTES) AND SPEED (WORDS/MINUTE)
FOR SACCADIC SCROLLING VERSUS TIMES SQUARE

| | VIEWING METHOD | | | | | |
|----------|--------------------|-------|-----------|-------|--------------|-------|
| | SACCADIC SCROLLING | | | | TIMES SQUARE | |
| | Manual | | Automatic | | | |
| | Time | Speed | Time | Speed | Time | Speed |
| Mean | 2.53 | 189 | 2.29 | 209 | 5.74 | 84 |
| Median | 2.36 | 203 | 2.25 | 213 | 5.46 | 88 |
| Std. Dev | 0.69 | | 0.61 | | 2.5 | |

TABLE 2-2

COMPREHENSION SCORES (% CORRECT) FOR
SACCADIC SCROLLING VERSUS TIMES SQUARE

| | VIEWING METHOD | | |
|----------|--------------------|-----------|--------------|
| | SACCADIC SCROLLING | | TIMES SQUARE |
| | Manual | Automatic | |
| | | | |
| Mean | 60.5 | 58.9 | 53.5 |
| Median | 67.0 | 50.0 | 58.5 |
| Std. Dev | 32.2 | 25.3 | 24.0 |

The only other message viewing option issue arises during text generation. In text generation, the limiting modality in message viewing is how fast the user can type, not how fast he can read, so reading speed is not a criterion. The Times Square mode does give a sense of continuity as words gradually disappear a character at a time, not a line at a time. Also, in comprehension, the Times Square mode compared favorable with Saccadic Scrolling. It is therefore felt that the Times Square viewing mode be provided as an option in text generation in the MAILPHONE follow-on effort. The prototype system, however, will have Saccadic Scrolling as the message viewing mode in all instances.

2.3.5 Pull-Out Keyboard. The MAILPHONE possesses a retractable keyboard that can be pulled out for message composition and can be tucked away upon message completion. The keyboard once out can rest on the desk in one of two user preferred positions: completely flat on the desk or slightly tilted. The custom-made keyboard fabricated by Silver Graphics, Inc. employs membrane technology. This technology is highly suited to making flat dirt-proof keyboards. A computer-generated "beep" that accompanies each keypress gives the keyboard a very positive feel. The keyboard features a full ASCII character set (Figure 2-2), 7 special function keys, CTL (control), SHIFT, SHIFT LOCK, and RET(URN). The single-line text edit keys include ↑, ↓, →, ←, DEL(ETE) and INS(ERT). The CTL key, a key similar to SHIFT, offers full functionality for the computer-oriented user by providing him both square and angle brackets often used in writing mathematical expressions. Pressing the RET(URN) key during text generation advances the display by one and left justifies the cursor. The edit keys and their associated functions are discussed in detail in the next subsection, MAILPHONE Text Editor.

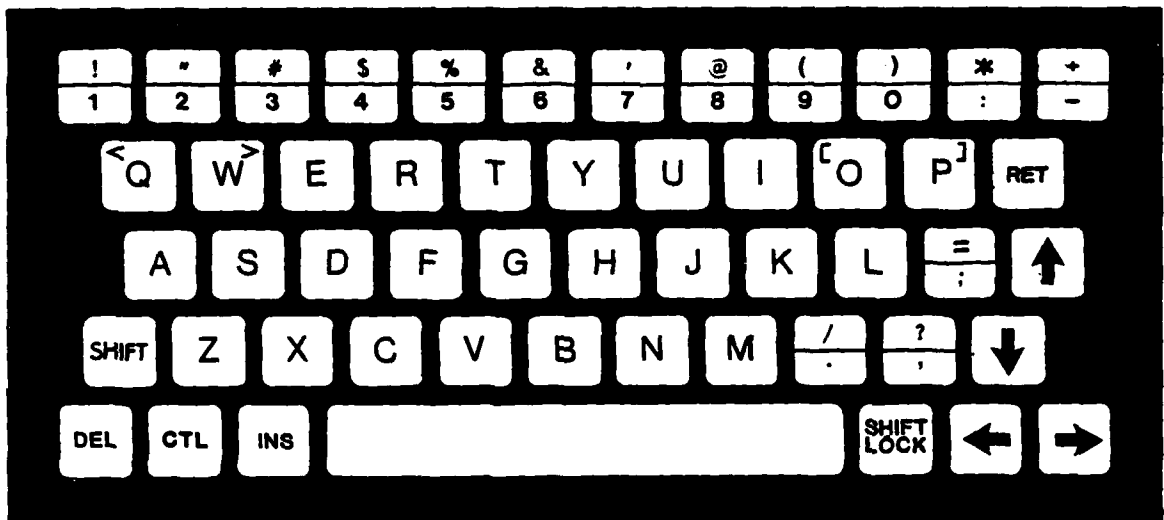





FIGURE 2-2
PULLOUT KEYBOARD

2.3.6 MAILPHONE Text Editor: Interface and Capabilities. The MAILPHONE system has a text generation and edit capability geared to a single line 40-character display. The specific edit keys and their functions are identified in the following paragraphs.

1.  This edit key is used to move the cursor to the right one character at a time. When the cursor is positioned on the 40th character, pressing this edit key results in the display of the next line with the cursor left justified.

2.  This edit key is used to move the cursor to the left one character at a time. When the cursor is positioned on the first character, pressing this edit key results in the display of the previous line with the cursor right justified.

3.  This edit key is used to display the previous line with the cursor in the exact same position. When the line being displayed is the first line, the display remains unaltered when this key is pressed.

4.  This edit key is used to display the next line of text with the cursor in the exact same position. When the line displayed is the last line of text, the display remains unchanged when this key is pressed.

5.  This edit key is used to display the next line of text with the cursor left-justified.

6.  The DEL(ETE) key is used to delete text one character at a time. When this key is pressed, the character under the cursor is deleted and all characters to the right of the cursor are shifted left by one column as shown in the figure below for the case when only two lines are present.

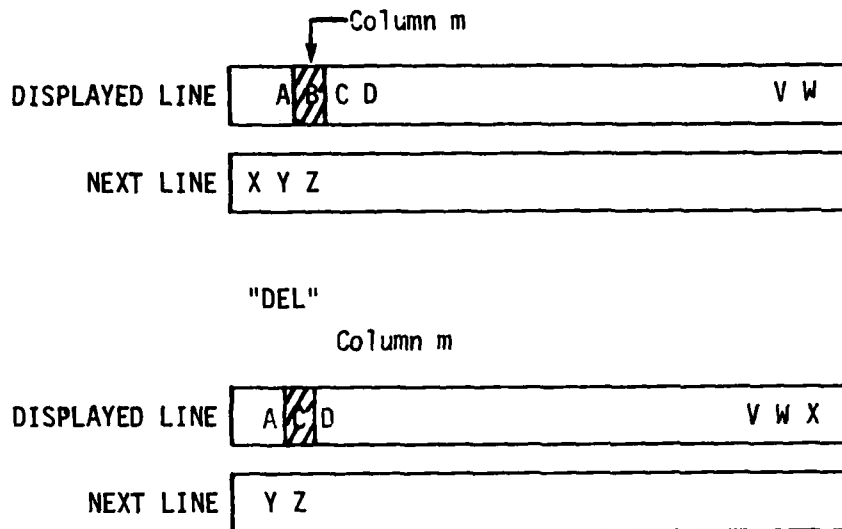

The DEL(ETE) key affects the displayed line and all subsequent lines. This means that characters on subsequent lines are moved left one column and that the character in column 1 of line n is moved to column 40 of line n-1 for all lines.

7. **INS** This key is used to insert character/text anywhere in the body of the message. Pressing the INS key followed by the characters to be inserted causes the inserted characters to appear in the display starting at the initial cursor position. The following illustrative example clarifies the use of the function.

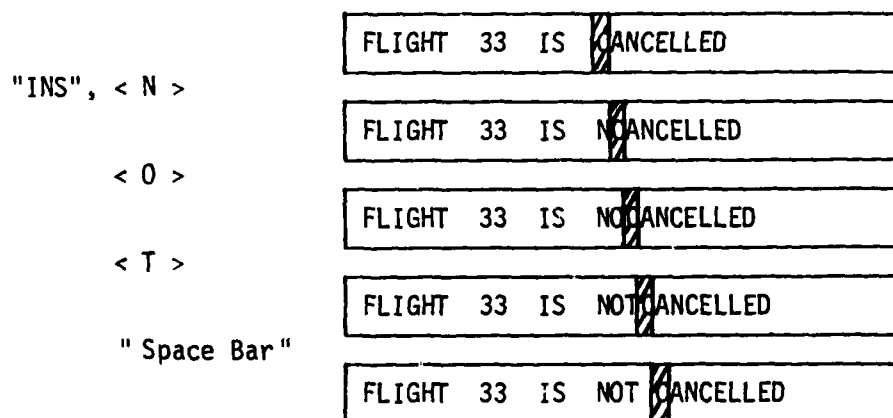

If insert results in greater than 40 characters (i.e., pushes a character over the right edge of the display), then:

- (1) The character that was pushed off the edge is saved.
- (2) The succeeding lines are searched until one is found that has a blank in column 40.
- (3) If the line found in step 2 is entirely blank, then (another) blank line is added before the "found" line and this new line is designated as the "found" line.
- (4) All characters in the "found" line are shifted to the right by one column.
- (5) The line immediately preceding the "found" line is designated as line n .
- (6) While line n is not the displayed line the following is done:
 - (a) The last character of line n is moved to column 1 of line $n+1$.
 - (b) All characters of line n are shifted to the right by one column.
 - (c) Designate line $n-1$ as line n .
 - (d) Back to step 5.
- (7) The character saved in step 1 is put into column 1 of line $n+1$.

2.4 MAILPHONE Interface Functions

The MAILPHONE functions are summarized in the function state overview diagram, Figure 2-3. The QUIESCENT state of the MAILPHONE is the top level or idle state, i.e., the state in which the MAILPHONE displays just the date and time and responds to outside calls and/or redials last busy

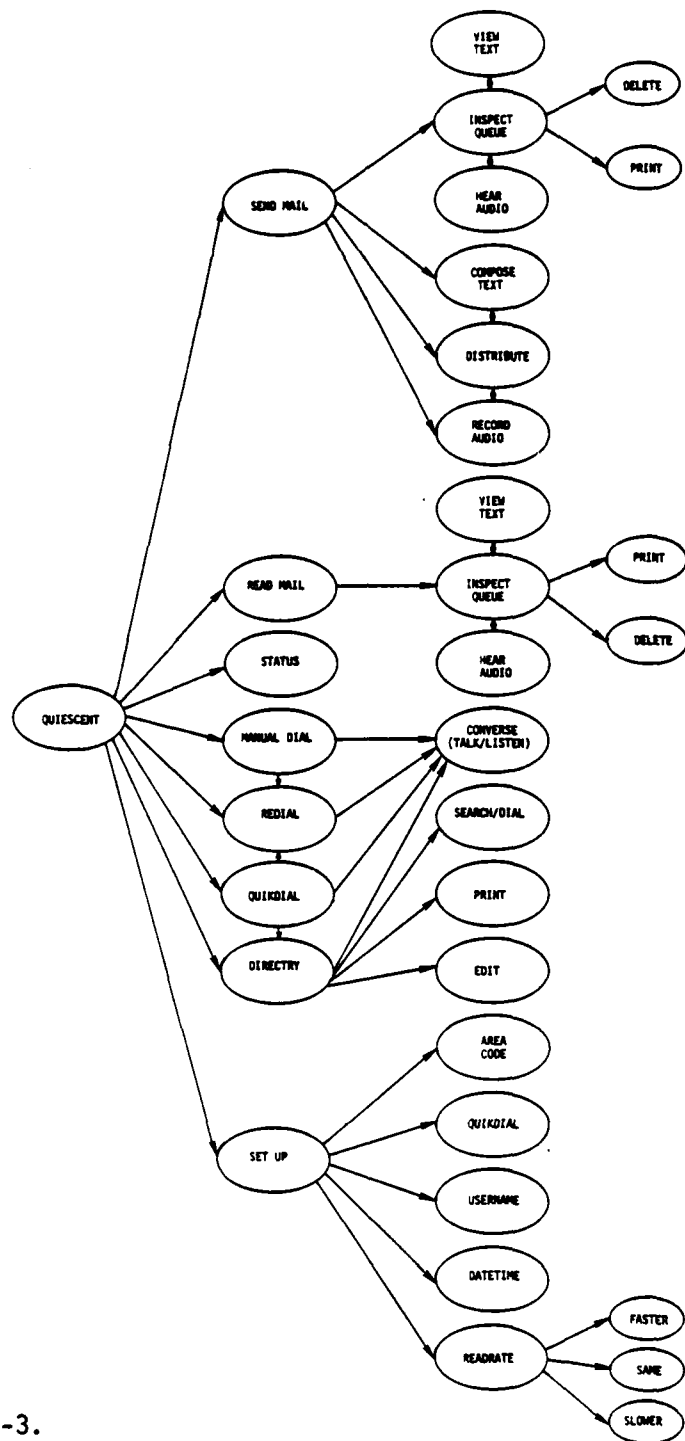

FIGURE 2-3.
MAILPHONE FUNCTIONAL HIERARCHY

number. From the QUIESCENT state, the user can press SENDMAIL, READMAIL, QUIKDIAL, STATUS, DIRECTORY, and SET UP. Under SENDMAIL, the user can create and distribute text and audio messages. Under READMAIL, the user can selectively view text messages or listen to audio messages. Under STATUS, the user can read the specific system problem or warning associated with a lit CHECK STATUS L.E.D. indicator. The DIRECTORY function allows the user to both modify (or update) and search the directory for the intended recipient's number, and call him. The SET UP function offers user-modifiable MAILPHONE personality. The QUIKDIAL key can be used to speed-dial a recipient's number without having to enter the whole number. The * key on the keypad performs the auto-redial function, i.e., when pressed after receiving a "busy" signal on a normal telephone call, it redials the previous unsuccessfully attempted number. The CANCEL key allows the cancelation of any ongoing activity. In the QUIESCENT state it can be used to turn QUIKDIAL off. The HELP key performs two functions: (1) it clarifies how data should be entered whenever data entry is required, and (2) it explains the variable legend menus associated with different levels of the functional hierarchy.

2.4.1 SENDMAIL Function. The SENDMAIL function of the MAILPHONE allows composition of textual and audio messages and review of the outgoing message queue. The SENDMAIL function state transition diagram is given in Figure 2-4.

The composition of a message involves either typing a message on a keyboard or recording a message through the handset. Each message has a fixed header that can be created before or after composing the message.

The outgoing message queue can be reviewed under SENDMAIL. The user can, if he wishes, cancel (i.e., delete) specific messages from the pending message queue.

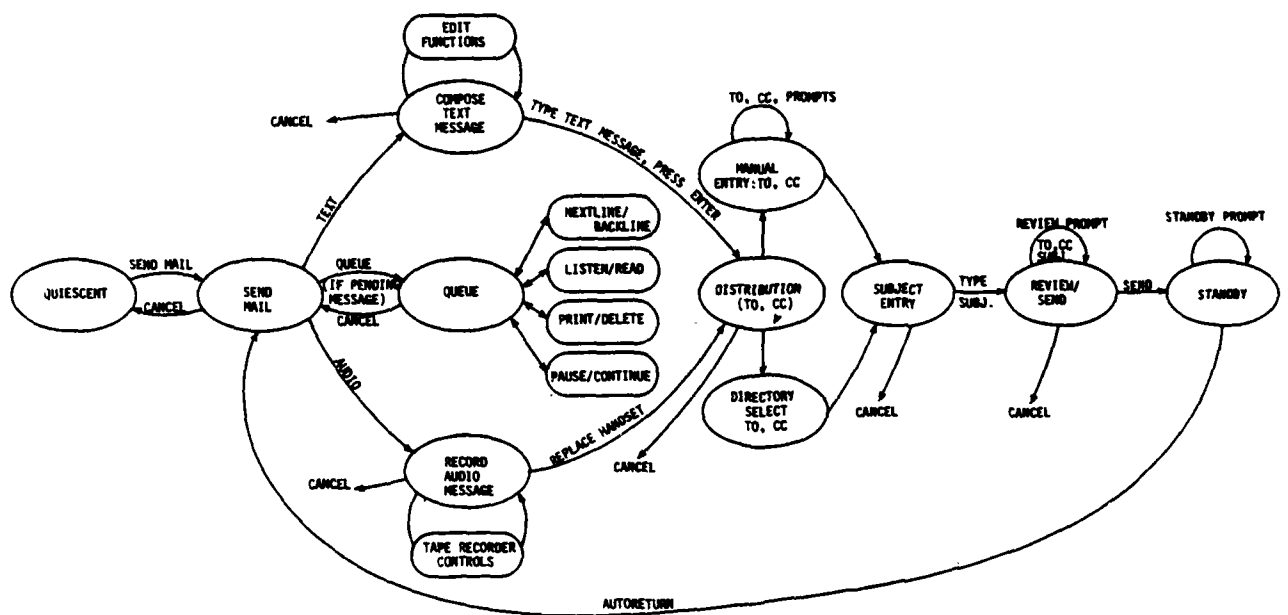

FIGURE 2-4.
SENDMAIL STATE TRANSITION DIAGRAM

Deletion of outgoing messages can be performed automatically or by user disposition. In instances where a message has not been disposed of by the user, the system will prompt the user for disposition if the available storage space falls below an a priori established threshold. If the user disregards the prompt, the system will start deleting the oldest messages to make room for new incoming messages or provide a busy indication to all incoming messages depending on the option specified by the user under the SET UP function.

2.4.2 READMAIL Function. The READMAIL function of the MAILPHONE allows the user to select a message that he wishes to see (or listen to) from his incoming message queue (see Figure 2-5). The legends that are then displayed on the variable legend function keys depend on whether the message is a text or an audio message. Upon message completion, the user can review the same message by pressing READ/LISTEN with the same message header showing through the 40-character display or use NEXTLINE/BACKLINE to locate a new message header and press READ/LISTEN to view/hear a new message. In this fashion, he can browse through the remaining entries in the queue with the help of NEXTLINE/BACKLINE user controls. The user can print and/or delete any message in the queue by simply locating that message in the 40-character display and pressing PRINT and/or DELETE. If a seen or heard message is not deleted by the user, it will automatically be deleted after a period of 24 hours.

2.4.3 DIRECTRY Function. The DIRECTRY function allows the user to: create a first time entry, modify an existing entry, locate an entry and "directory dial." Upon pressing DIRECTRY, the user is requested to select the alphabetic category containing the first letter of the persons name the user wishes to add, change or dial. Upon selecting this category, the user can directory-dial after locating the caller's name on the 40-character display, go back to the DIRECTRY to make a new alphabetic category selection

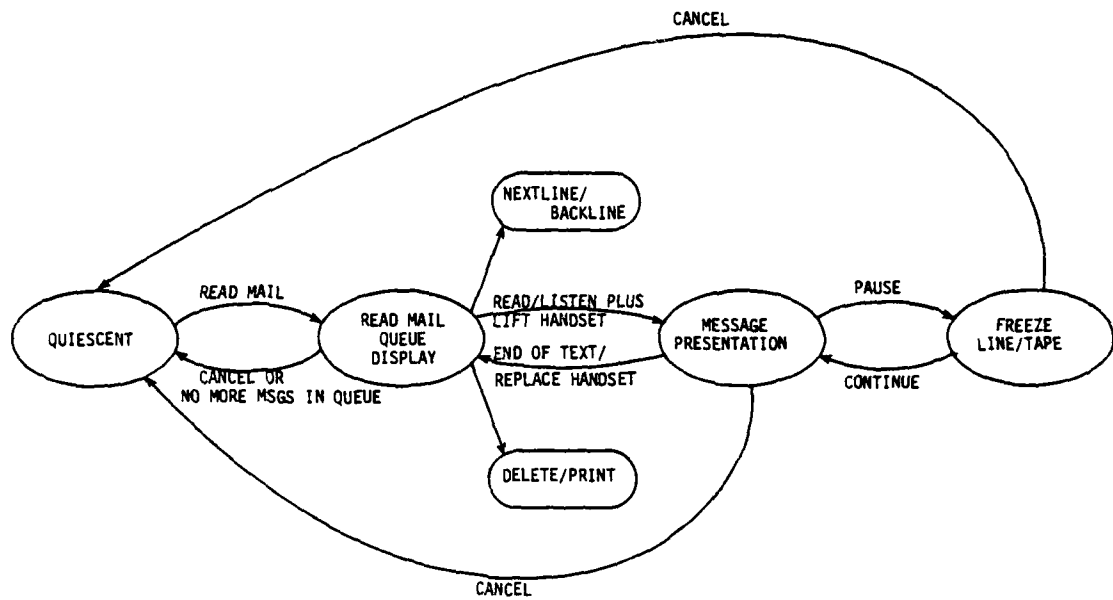

FIGURE 2-5.
 READMAIL STATE TRANSITION DIAGRAM

or press MODIFY. Under MODIFY, the user can browse through the directory and/or add, change, delete entries, or go back to the DIRECTORY for a new selection. The DIRECTORY function state transition diagram is given in Figure 2-6.

2.4.4 SET UP Function. The SET UP function allows the user to "personalize" the MAILPHONE. Under SET UP the user can (a) enter his name, area code, and dial-out prefix, and (b) set the time, time display format and viewing rate of text messages or prompts. The SET UP function state transition diagram is given in Figure 2-7.

2.4.5 QUIKDIAL Function. The QUIKDIAL function is an executive telephone function. Upon pressing QUIKDIAL, the system requests the user to enter the 2-digit directory code. Upon entering the directory code of the intended recipient, the system displays the recipient's name and number for confirmation. When the user presses DIAL, the system "speed-dials" the recipient's number. A dialing prompt is displayed to the user when the dialing operation is in progress. When the dialing operation is complete, the system requests the user to lift the handset. The QUIKDIAL function state diagram along with manual telephone dialing is provided in Figure 2-8.

2.4.6 REDIAL Function. REDIAL facility is provided to the MAILPHONE user following normal dialing, QUIKDIALing, or "directory-dialing" functions. Pressing the "*" key on the keypad after hanging up results in a "timed" prompt "PRESS * TO REDIAL" that stays up on the 80-character display for approximately 4-5 seconds. Displayed alongside this prompt is the last attempted number so that the user has prior confirmation regarding which number would be dialed if he pressed '*'.

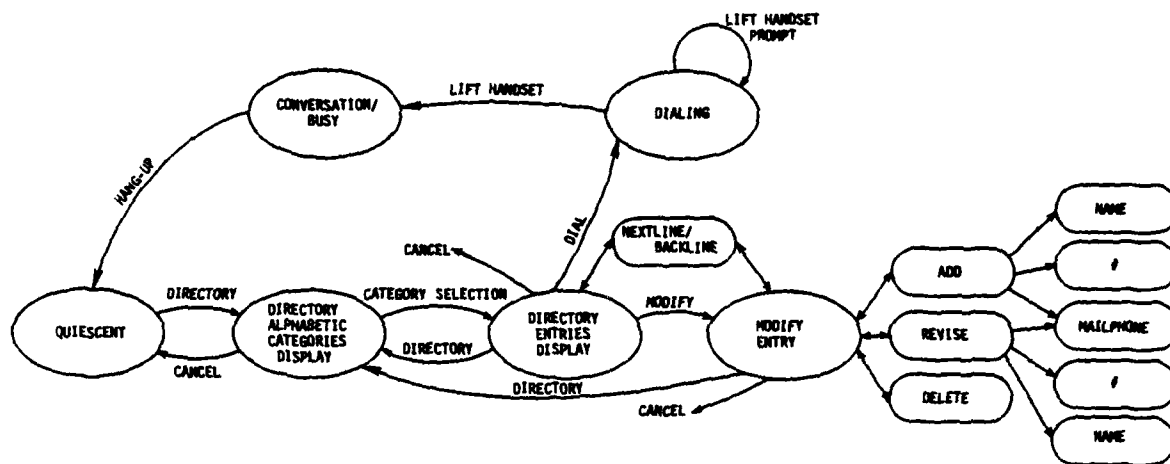

FIGURE 2-6.
 DIRECTORY STATE TRANSITION DIAGRAM

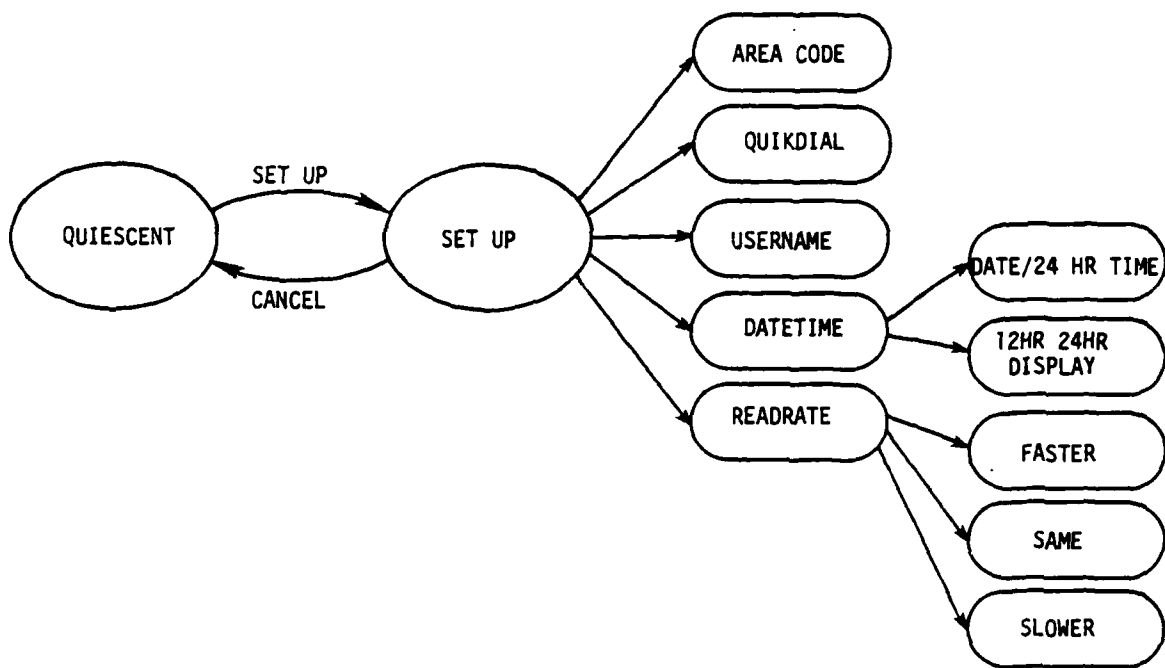

FIGURE 2-7.
SET UP STATE TRANSITION DIAGRAM

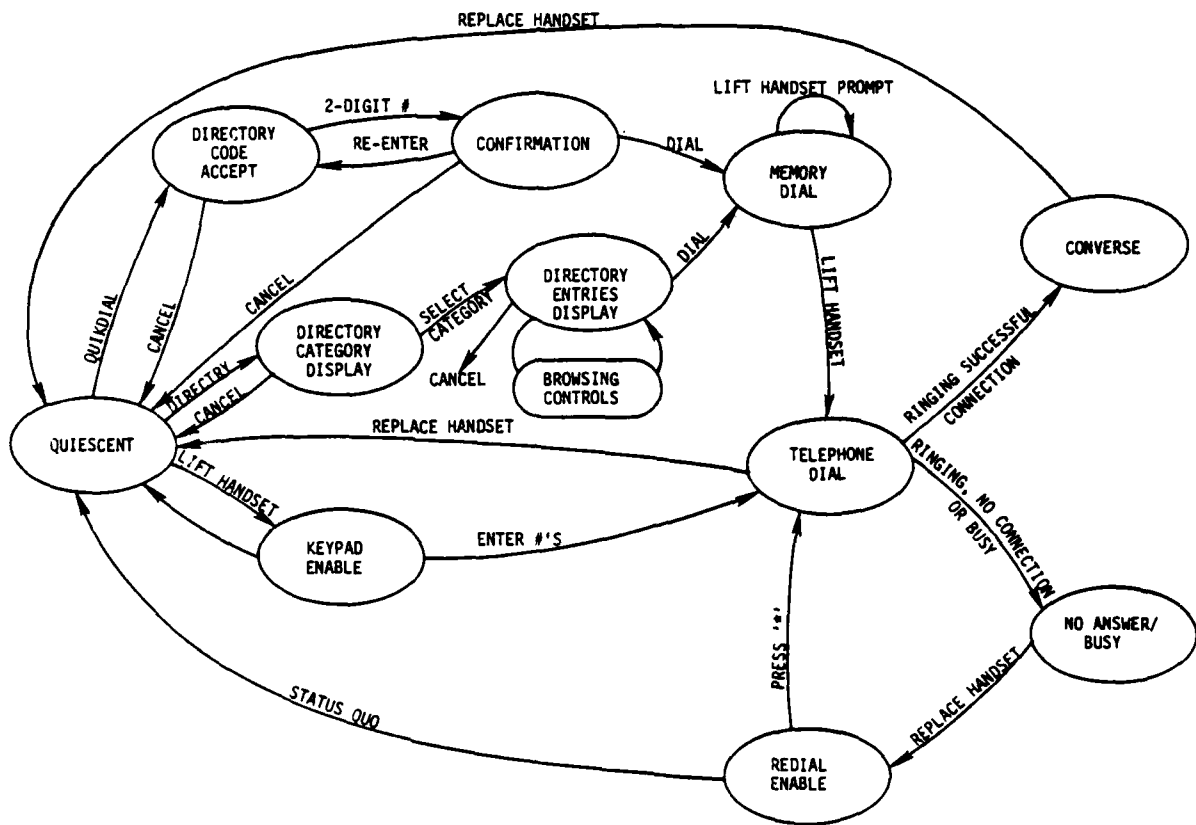

FIGURE 2-8.
TELEPHONE FUNCTION STATE TRANSITION DIAGRAM

2.4.7 STATUS Function. The purpose of the STATUS function is to provide the user with specific diagnostic or maintenance information to rectify the problem associated with a lit CHECK STATUS indicator. For instance, when the blank space for recording an audio tape approaches a certain minimum level (duration), a warning is displayed to the MAILPHONE user requesting the user to selectively erase audio messages from the READMAIL queue.

2.4.8 HELP Function and System Prompts. As discussed earlier, the casual user cannot be expected to remember a system's details over long periods of time. Consequently, it is necessary that at each point when the user has to perform some action, the possible choices are always available or easily accessible to him. It is equally important to recognize that there is little value in initial training which includes substantial indoctrination in the details of system usage-- rather, it is important to instill a sound understanding of the system. Many errors in practical use arise from a mismatch between the system and the user's model of it. Since this class of user may not tolerate much training, it is best to expose him to that which is essential and retained most easily. Therefore, initial instruction should be a short and clear indoctrination in the principles of the interface. In the case of the MAILPHONE, it is important to primarily orient the user in the MAILPHONE function state space by identifying the options open to him and then guide him through the entire transaction associated with the selection of each option. To this end, the MAILPHONE is provided with a HELP function. The HELP function indoctrinates the MAILPHONE user in system functions by explaining to the user the possible electronic mail handling and telephone functions associated with each top level function. The variable legend menus at each level in the functional hierarchy and the associated system prompts subsequently guide the user to the logical conclusion of each transaction.

The MAILPHONE makes it clear to the user when it is his turn to make entry by issuing a suitably designed unambiguous prompt. A side benefit of the system prompt is that it reassures the user of where his particular action fits in the progress of the man-computer dialog. The latter is a distinct advantage since a casual user can easily lose track of his progress because of his relative unfamiliarity with the system. Parsons (1972) makes this point after studying the results of many man-machine system related experiments:

"When an operator has to keep shifting between different task elements, his performance is aided by displays which indicate what he has done and should do in each instance. Otherwise, his short term memory becomes overburdened."

Situations are bound to arise, when a user, in order to select from among the choices offered by the system, requires more information than is currently displayed to make the selection. The user may have forgotten an earlier prompt, be uncertain of the meaning or consequence of some choice, or want to explore a little first. Ideally, it should be possible to suspend the current state, find out the information needed, and return to the original state. The mechanism for doing this needs to be simple (easy to remember) and consistently applicable in whatever state the system is. The HELP function provides this capability. Upon pressing HELP, the displayed variable legend menu remains unaltered. The system's response to HELP appears in place of the previously displayed prompt. The user can then continue on from the current state by either making an appropriate selection from the displayed variable legend menu or typing on the keyboard.

2.4.9 CANCEL Function. The CANCEL function is provided at every level of the functional hierarchy to abort any on-going activity and return to the QUIESCENT state.

3. PROTOTYPE SYSTEM DESIGN

The MAILPHONE electronic hardware functionally consists of two main units: the Desk Unit and the Control Unit. The Desk Unit is the visible part of the system and functions as the primary interface to the user. The Control Unit, located remotely from user view, houses the main system computer, audio cassette recorder (ACR), MODEM and associated electronics, and dual floppy disks (see Figure 3-1). The Control Unit initiates all software processes based on both user inputs (from the Desk Unit) and other peripheral inputs such as incoming messages detection by the MODEM. The Control Unit-Desk Unit Interface communication is accomplished using the serial RS-232 interface hardware protocol. This form of communication allows the Control Unit to be remotely isolated from the Desk Unit. These two units along with the thermal printer comprise the MAILPHONE system.

The MAILPHONE is equipped with two telephone lines; one for live calls and the other dedicated to electronic mail. The live call line can be directly switched to the handset while the other line connects to the computer via the MODEM. The main reason for having a separate line dedicated to live calls is to ensure that a digital call cannot be intercepted by a receptionist or secretary who has no way of distinguishing between a live caller and a digital call when the phone rings. This situation is likely to occur quite frequently if all calls came in on a single line to a multi-phone line environment in which a receptionist or secretary generally answers the call first prior to "buzzing" the executive.

3.1 Desk Unit

The primary function of the Desk Unit is to interface with the MAILPHONE user. This user interface is characterized in terms of user inputs and system outputs defined in Table 3-1.

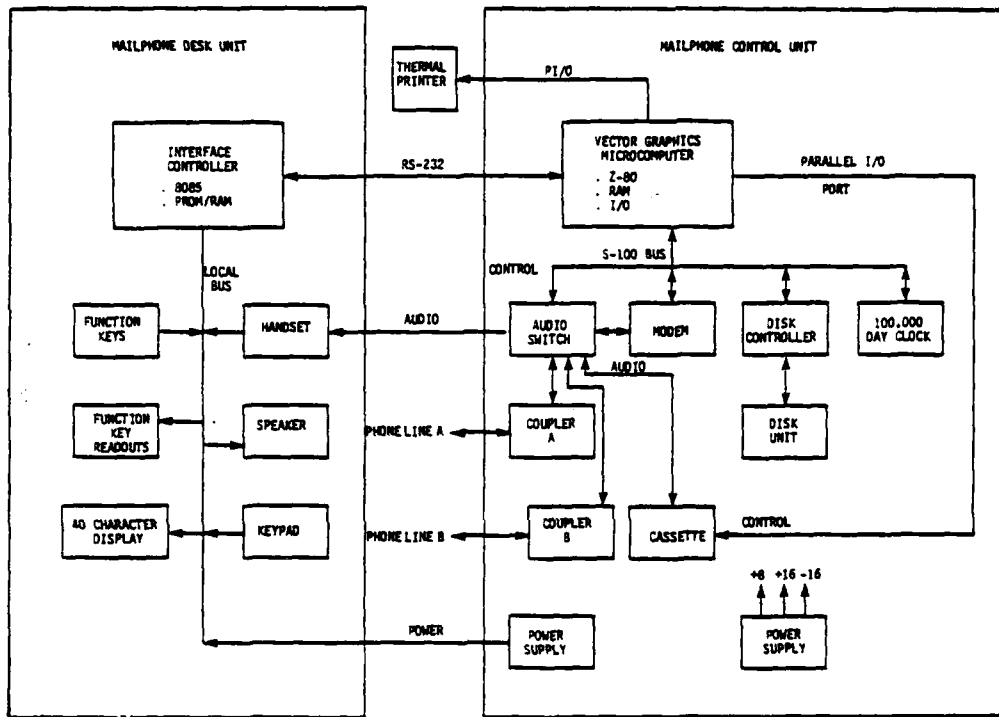

FIGURE 3-1.
MAILPHONE ORGANIZATION

TABLE 3-1
DESK UNIT I/O*

| <u>INPUTS</u> | <u>OUTPUTS</u> |
|--------------------------|-----------------------------------|
| 1. Function Keys | 1. 40-Character Display |
| 2. Keypad | 2. 64-Character Function Legends |
| 3. Alphanumeric Keyboard | 3. Audio Speaker |
| 4. Handset Switch | 4. CHECK STATUS/AUTODIAL L.E.D.'s |

All Desk Unit inputs from the user are encoded as defined in Appendix G and sent to the Control Unit. All Desk Unit outputs (feedback to the user) are generated from commands and data received from the Control Unit.

Each of these interface devices (switches and displays) is controlled by an 8085 microprocessor and its associated electronic software. The interface between the 8085 microprocessor and the various input-output devices is described in the following subsections.

3.1.1 Alphanumeric Keyboard. The 53-character alphanumeric keyboard is configured as a 5 X 12 matrix of contact switches such that as each column is enabled, i.e., set to a logic 1 by the 8085, the rows can then be input to the microprocessor and the closure of a switch contact can then be detected. For individual keyboard position assignments and port addresses refer to Figure 3-2. Two switches on the keyboard, designated "SHIFT" and "CTL" (control) are read from another address port (1BH), bits 0 and 1, and require no column drive output by the microprocessor.

3.1.2 Keypad and Function Keys. The 12-position touchtone keypad along with the 8 function keys are configured in a 5X4 matrix of switches similar in layout to the keyboard switches. The column drives (microprocessor output port) are the 5 least significant bits of the column address port (10H) and the row inputs are the 4 least significant bits of the row address port (19H). Figure 3-3 gives the keypad switch position (1-9, #, *) along with the function switches (FS0-FS7) positions and associated row/column assignments.

*The Control Unit which is both an input and output port for the Desk Unit does not interface with the user.

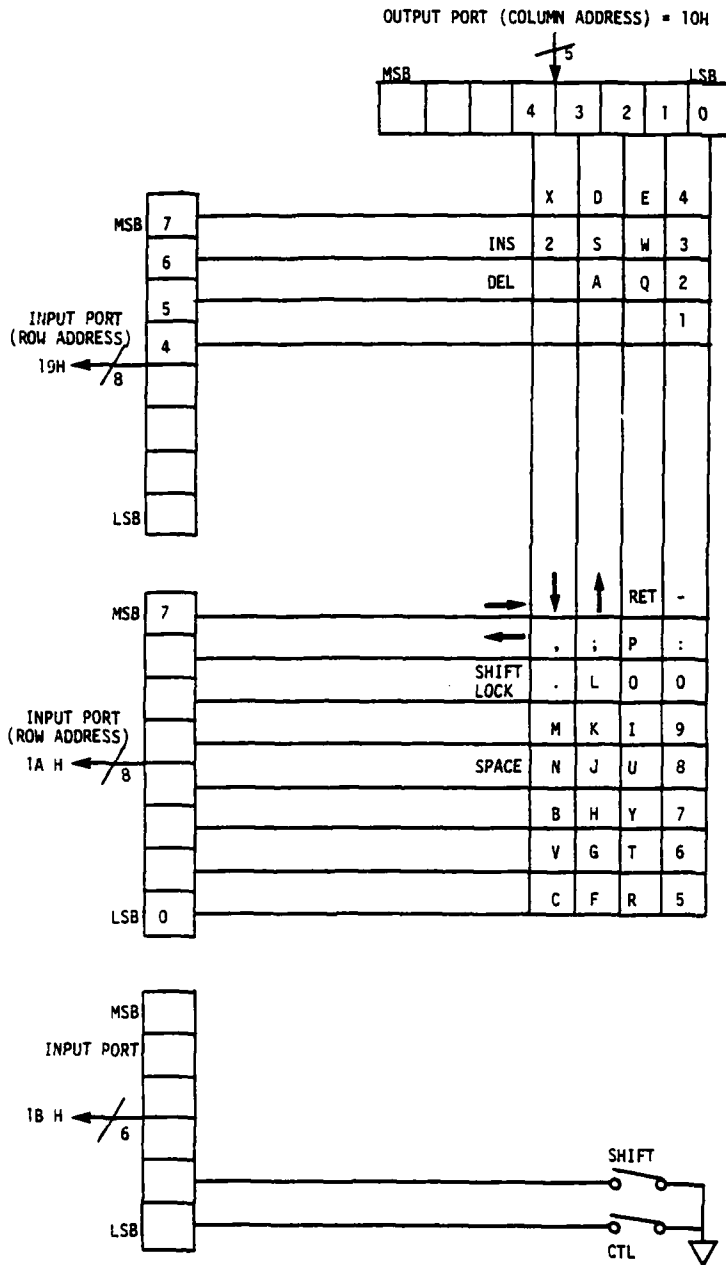

FIGURE 3-2.
KEYBOARD MATRIX/MICROPROCESSOR INTERFACE CONFIGURATION

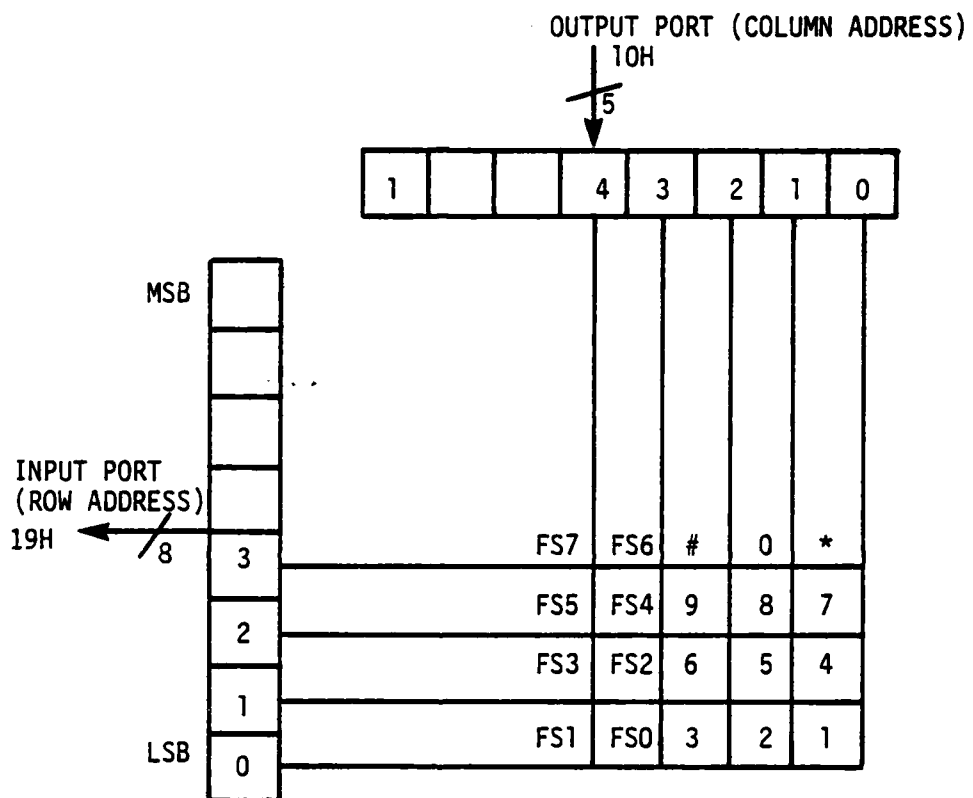

FIGURE 3-3.
KEYPAD ROW-COLUMN ASSIGNMENT

3.1.3 Displays. The Desk Unit displays are viewed by the user as a single line of 40 characters along with 8 lines of 8 characters associated with each of the function key legends. All characters are displayed in a 5X7 dot matrix configuration (HP 2001). The row information for all 104 characters (40 + 8 X 8) is loaded into the display output port location (H) and the 5 columns for all of the 104 characters are multiplexed at a 4 millisecond rate. Thus all 5 columns for the 104 characters are refreshed at a 20 millisecond rate. This timing is critical for a flicker-free display. An interrupt is generated to the 8085 microprocessor at the rate of 25 hertz from a standard one-shot timing circuit. This interrupt activates the refresh processing cycle for the displays.

3.1.4 Handset Switch. The handset switch is a single pole switch read as an input to the microprocessor from the handset cradle as the handset is picked-up by the user. The input port address for this switch is 31H and the most significant bit of this port is used by the microprocessor for the switch closure indication.

3.2 Control Unit

The Control Unit performs the function of the MAILPHONE system controller. It interfaces and controls the following system hardware devices:

- (1) MODEM/Coupler.
- (2) Audio Cassette Recorder.
- (3) Audio Switch.
- (4) Thermal Printer.
- (5) Floppy Disk.
- (6) Desk Unit.
- (7) 100,000 Day Clock.

All of these units, with the exceptions of the Desk Unit and Printer, are housed in a Vector Graphics, S-100 Bus configured mainframe along with the microcomputer and associated interface circuitry. Additionally, the

Control Unit houses the power supply for all internal electronic hardware and for the Desk Unit. Refer to Figure 3-1 for the Control Unit interconnect diagram.

Control Unit Fabrication. The Control Unit is constructed using the Vector Graphics mainframe which includes the following:

- (1) S-100 bus motherboard (18 card slots).
- (2) Power supply.
- (3) Mini Floppy drive.
- (4) Air cooling Rotran Whisper fan.

Added to this mainframe are the following components which constitute the functional MAILPHONE Control Unit hardware:

- (1) Z-80 CPU.
- (2) 65K dynamic RAM.
- (3) PROM/RAM board.
- (4) I/O Interface.
- (5) 80 X 24 memory mapped video board.
- (6) MODEM.
- (7) Disk Controller.
- (8) 100,000 Day Clock.
- (9) Desk Unit power supply.
- (10) Audio Switching Module
- (11) Couplers (2).
- (12) Audio Cassette Recorder.
- (13) Dual Floppy Disks.

Refer to Figure 3-4 for a pictorial sketch of the Control Unit hardware. The first 8 items listed above are S-100 bus compatible cards that can be inserted into any of the 18 card slots provided by the Vector Graphics motherboard. These functional cards are standard "off-the-shelf" type boards and when configured together form a basic microcomputer system. Data sheets are provided in Appendix B for the 100,000 Day Clock, Cassette, MODEM, and Desk Unit power supply.

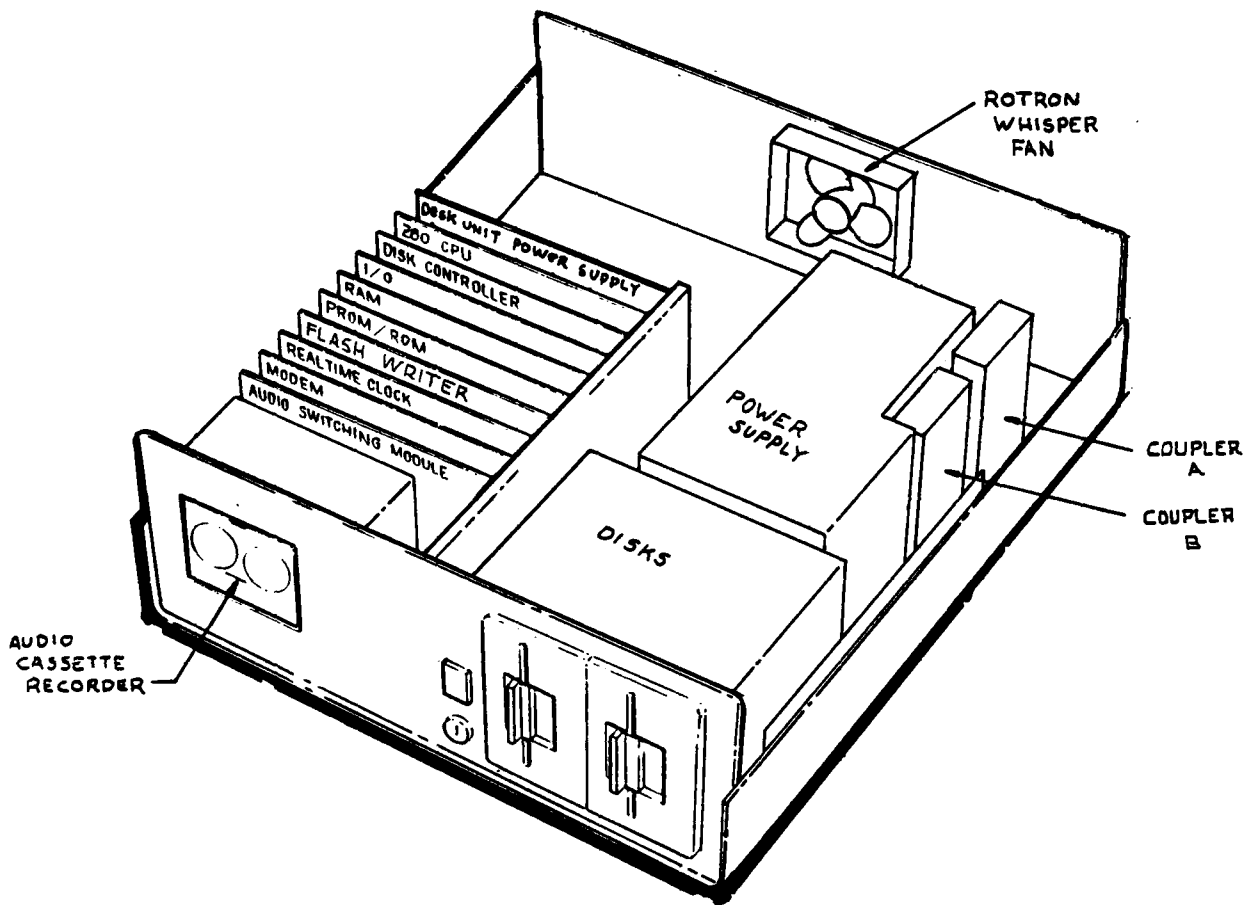

FIGURE 3-4.
CONTROL UNIT LAYOUT

The Desk Unit power supply and the custom Audio Switching module are mounted on S-100 bus compatible cards and inserted into the S-100 bus motherboard as shown in the figure. The front panel of the Vector Graphics mainframe has been modified to accommodate the Audio Cassette Recorder (ACR). The ACR and its own power supply are mounted inside the mainframe and attached to the front panel. A slot cut in the front panel permits easy access to the cassette tape. The ACR unit extends over the front four S-100 bus card slot locations which have been removed for this unit.

The two phone line couplers are mounted directly to the Vector Graphics mainframe as shown in the figure. The dual floppy disk drives are mounted to the mainframe. The slots are provided by the Vector Graphics mainframe front panel.

3.2.1 Microcomputer. The Vector Graphics microcomputer consists of the Z80 microprocessor, associated memory, S-100 bus interface logic and various input/output (I/O) ports. This configuration is particularly suitable for the MAILPHONE system controller in that event-driven, real-time processing can be accomplished using hardware-generated vectored interrupts to drive functionally partitioned software control programs.

The Vector Graphics microcomputer system provides the following, in addition to the Z80 microprocessor:

- (1) 64K* words of random access memory (RAM).
- (2) Two 8-bit parallel I/O ports.
- (3) One serial RS-232 compatible I/O port.

* K = 1024

- (4) Dual floppy disk controller.
- (5) S-100 bus motherboard.

The RAM is used for software programs and data bases. One parallel I/O port is used for the Audio Cassette Recorder (ACR) interface, while the second is used for printer communication. The RS-232 serial port provides microprocessor interface to the desk unit. The S-100 bus motherboard provides the communication interface between the S-100 bus compatible hardware modules and the microprocessor. These include (a) Disk Controller, (b) MODEM, (c) 100,000 Day Clock, and (d) Audio Switch. Each of these peripheral devices are discussed in the following subsections.

3.2.2 MODEM/Coupler. A MODEM is a device that converts digital data from a computer, or terminal to a modulated carrier waveform required by the communication channel. At the other end of the link, the demodulator of a second MODEM reconverts the analog signals to digital outputs. Use of MODEMs on the dial-up facilities of the telephone company require that the user interface his MODEM to the line with a coupler device. The MAILPHONE uses an FCC registered protective coupler. Its purpose is to protect the computer user and telephone network from the harmful effects of high voltage spikes and excessive signal levels. It also insures that the telephone billing equipment will properly register and time the calls.

The MAILPHONE system MODEM hardware is configured as depicted in Figure 3-5. This figure shows two couplers (A & B) for interfacing with two phone lines. Coupler A is used in conjunction with the MODEM for the transmission of both audio and digital electronic mail. Coupler B is used for live audio calls, i.e., normal telephone communication. The

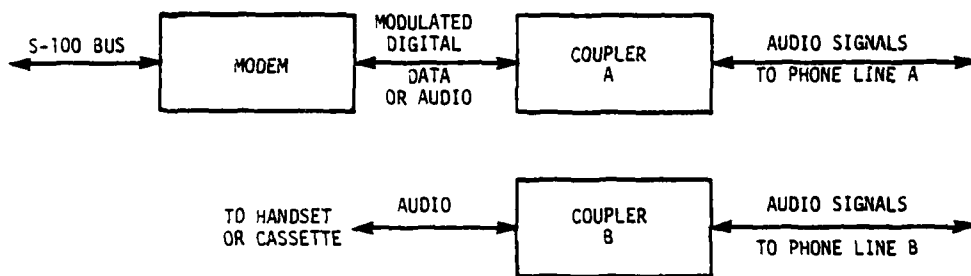

FIGURE 3-5.
MAILPHONE MODEM/COUPLER CONFIGURATION

control that determines which coupler ought to be used is performed by the Control Unit through a device termed "AUDIO SWITCH" described under Section 3.2.3.

The MODEM used in the MAILPHONE system is the D.C. Hayes Associates, S-100 bus compatible MICROMODEM 100. This MODEM possesses the following features:

- (1) FSK modulation technique.
- (2) 300 baud maximum transfer/receive rate (30 characters/sec.).
- (3) Full duplex operation (simultaneous two-way communication).
- (4) Carrier detect indication (used to detect "phone-answer" at the receiving phone).
- (5) Lost carrier detect (indication that receiving phone is back on-hook).
- (6) Phone ring indication.
- (7) Transmit/receive registers full (used to synchronize hardware and software data transmission and reception).
- (8) 50 Ms time-out (used for timing during dial).

Items 4 through 8 also provide S-100 bus type interrupts to the micro-computer system for rapid context switching in a real-time environment or system configuration.

3.2.3 Audio Switch. The Audio Switch is an S-100 bus configured module, controlled by the microcomputer, which performs several functions in the MAILPHONE system related to the transfer of audio signals between various system modules. All audio signals are routed through a switch network of the Audio Switch module to one of several destinations. These include

the ACR, Handset, MODEM, and two Couplers. Additionally, the Audio Switch module provides the digital control interface to the ACR, Coupler B and generates the touchtone signals for user feedback while dialing.

The Audio switching function performed by this module is represented logically in Figure 3-6. The Audio Switch module accepts software commands (issued by the microcomputer) that specify switch openings and closures thereby interconnecting two or more audio devices. The switching network has two audio buses, B1 and B2. Any individual switch connects an audio device to one of the audio buses. A typical connection between two devices is made by the microcomputer with the setting of two bits in the output command byte. The correspondence of actual switches to audio devices may be determined from the logic drawing of Figure 3-6. Table 3-2 defines a matrix of allowable settings for the commonly used connection pairs. Each column entry in the table represents a connection of that device with the device in a given row. The entry of B1 or B2 indicates which of the two audio buses in the switch network is used for that connection (refer to Figure 3-6) while an "X" indicates that no connection is possible.

Table 3-3 presents a list of the allowed (i.e., connectable) combinations of audio devices.

The touchtone generator provides audible feedback to the MAILPHONE user through the handset when keys on the telephone keypad are pressed. The tones are generated by a special purpose electronic chip controlled by seven bits from the microcomputer (output port 62H). The specific combinations of bits that produce tones are indicated in Table 3-4.

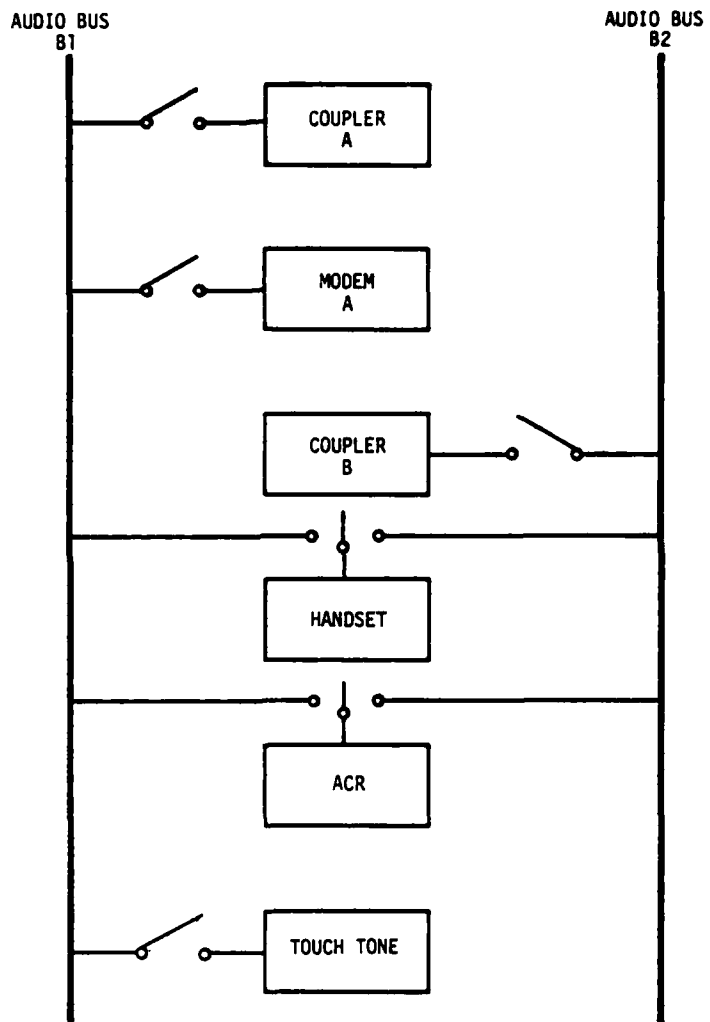

FIGURE 3-6.
AUDIO SWITCH MODULE SWITCHING NETWORK LOGIC DIAGRAM

TABLE 3-2
AUDIO SWITCH MODULE DEVICE INTERCONNECT MATRIX

| AUDIO DEVICES | MODEM | ACR | HANDSET | TOUCHTONE |
|---------------|-------|-----------------|---------|-----------|
| Coupler A | B1 | B1 | X | B1 |
| Coupler B | X | B2 ² | B2 | B2 |
| Handset | X | B2 | X | B1 |

TABLE 3-3
AUDIO SWITCH ALLOWABLE CONNECTION PAIRS

| CONNECTION PAIR | CONCURRENT CONNECTION PAIR ² |
|------------------------|---|
| 1. Coupler A/MODEM | Coupler B/ACR ² Coupler B/Handset Handset/ACR Handset/Touchtone |
| 2. Coupler A/ACR | Coupler B/Handset Handset/Touchtone |
| 3. Coupler A/Touchtone | Coupler B/ACR ² Handset/ACR Handset/Touchtone |

¹Only one connection pair of those listed can be selected.

²Not used in the prototype system.

TABLE 3-4
TOUCHTONE GENERATOR OUTPUT CODES

| KEYPAD ENTRY | OUTPUT BYTE (HEX) |
|--------------|-------------------|
| 1 | 11 |
| 2 | 21 |
| 3 | 41 |
| 4 | 12 |
| 5 | 22 |
| 6 | 42 |
| 7 | 14 |
| 8 | 24 |
| 9 | 44 |
| x | 18 |
| 0 | 28 |
| # | 48 |

The tone from the generator chip is connected into the Audio Switch module switching network as shown in Figure 3-6. The touchtone generator can only be connected to the handset and to either Coupler A or B.

3.2.4 Audio Cassette Recorder (ACR). The ACR used in the MAILPHONE system is the Triple I PHI-DECK recorder. This unit provides the following interface control functions to the microcomputer system.

- (1) Fast Forward.
- (2) Rewind.
- (3) Playback.
- (4) Record.
- (5) Stop.

These commands are generated from the microcomputer output port (63H) to the Audio Switch module where due to the available space the ACR interface logic is implemented. The record/playback speeds are 1-7/8 ips and the fast forward and rewind times are less than 35 seconds for a C-60 cassette.

The PHI-DECK ACR unit generates 18 interrupts per revolution of the takeup reel to the microcomputer. These interrupts are then used by the software for audio tape file management and record-head positioning.

Additionally, specific status indications are provided at the microcomputer input port (62H). These include:

- (1) End of tape/beginning of tape.
- (2) Stop.
- (3) Run.
- (4) Fast Forward.
- (5) Rewind.

3.2.5 Printer. The printer used in the MAILPHONE system is a TRENDCOM 200 high-speed intelligent printer. This device prints up to 40 characters per second and up to 80 characters per line. The TRENDCOM 200 requires no external power supplies. The TTL-compatible input interfaces directly to the eight-bit parallel I/O port of the Control Unit. It is a true intelligent printer with full line buffering, i.e., one full line of characters accepted by the device before actual printing, and bi-directional look-ahead printing. The contents of the buffer are printed following receipt of a carriage return code (DDH) or upon receipt of the 81st character. Upon one line being printed left to right, the internal micro-processor examines the next line and selects the most efficient printing direction, either returning to the left margin, or moving to the location for the last character in the next line and printing it right to left. The 5X7 dot matrix characters are printed in a ten character-per-inch format. The printer incorporates a built-in self-test capability, activated by a slide-switch inside the printer. When this switch is activated, the unit if functioning properly continually prints a predefined message. (Self-Test overrides the external input from the Control Unit.)

3.2.6 Power Supply. The Control Unit houses two separate power supplies. One supplies the power for the microcomputer system, including the floppy disks and all S-100 bus-compatible card modules. This power supply is part of the Vector Graphics mainframe. It generates the following voltage/current specifications:

- (1) + 8V/20A.
- (2) + 16V/25A.
- (3) - 16V/25A.

These voltages are supplies unregulated to the S-100 bus where each of the individual card modules contain the required regulators.

The second power supply generates the regulated +5 volts (maximum current of 12 amps) used by the Desk Unit. The unit is a Power General Switching power supply with an efficiency rating in excess of 75%. This power supply is mounted inside the Vector Graphics mainframe instead of the Desk Unit in order to limit Desk Unit size and conserve space.

3.2.7 100,000 Day Clock. The 100,000 Day Clock is a S-100 bus compatible card module supplied by Mountain Hardware, Inc. This device is used by the MAILPHONE system for date and time information. It will keep track of time in 100 microsecond intervals, up to 100,000 days. CMOS circuitry is employed in the design of the device which allows the clock to be run off a 9-volt battery for up to four days while the Control Unit is shut down or if AC power fails. The Clock uses 15 I/O ports for the time plus one I/O port to set the interrupt function. The Clock is set by entering BCD digits one at a time at each time port. When the first digit is entered, the clock stops and then the remaining digits are entered. The Clock then starts on the first read command from the microcomputer. Table 3-6 shows the significance of each of the 16 I/O ports and the time range associated with that port. Each digit of time is made available as the microcomputer reads the proper port numbers.

3.3 Control Unit-Desk Unit Interface

The hardware interface between the Control Unit and Desk Unit is the RS-232 standard interface and protocol. This hardware interface is used by the software of both the units in order to communicate commands and data. Information passes from the Desk Unit informing the Control Unit of various requests made by the user and likewise, the Control Unit passes information to the Desk Unit, to indicate to the user, various states of the system in the form of displays and sounds. Appendix A gives the details and contents of the information that is transmitted and received between these two units. The objective of the design given is to minimize the amount of data on the interface, allowing for maximum processing time in both the Desk Unit and Control Unit with minimum error from the interfaces.

TABLE 3-6
100,000 DAY CLOCK PORT SIGNIFICANCE

| PORT ADDRESS | PORT SIGNIFICANCE | TIME RANGE |
|--------------|-----------------------|----------------|
| Lowest | 100 us (microseconds) | 0-9 |
| Lowest +1 | 1 ms (milliseconds) | 0-9 |
| Lowest +2 | 10 ms | 0-9 |
| Lowest +3 | 100 ms | 0-9 |
| Lowest +4 | 1 second | 0-9 |
| Lowest +5 | 10 seconds | 0-5 |
| Lowest +6 | 1 minute | 0-9 |
| Lowest +7 | 10 minutes | 0-5 |
| Lowest +8 | 1 hour | 0-9 |
| Lowest +9 | 10 hours | 0-2 |
| Lowest +10 | 1 day | 0-9 |
| Lowest +11 | 10 days | 0-9 |
| Lowest +12 | 100 days | 0-9 |
| Lowest +13 | 1,000 days | 0-9 |
| Lowest +14 | 10,000 days | 0-9 |
| Highest | Interrupt port | 0-14 (0-E Hex) |

4. PROTOTYPE SOFTWARE DESIGN

The MAILPHONE software is functionally partitioned between the Desk Unit and the Control Unit. Software functions associated with the Desk Unit are directly related to the user interface. These include:

- (1) 40-character legend display and update.
- (2) Keyboard/keypad input processing.
- (3) Function key selection processing.
- (4) Sounds generation (beep, click, ring).
- (5) Handset on/off hook detection.
- (6) L.E.D. on/off indication.

The Control Unit views all other peripheral units, including the Desk Unit, as I/O devices. Software functions associated with the Control Unit directly control the MAILPHONE activity and general processing. Control Unit functions include processing:

- (1) Desk unit interrupt.
- (2) Peripheral interrupt.
- (3) State transitions.
- (4) External telephone communications.

The following subsections describe in detail the functional software for these units.

4.1 Desk Unit Software

The Desk Unit is capable of both transmitting and receiving encoded commands to/from the control unit via an RS-232 data communication link. User-generated interrupts in the form of: (1) function key presses, (2) keypad/keyboard character depress, and (3) handset on/off hook indication are encoded by the Desk Unit and sent on to the Control Unit.

In response to the Control Unit, the Desk Unit software updates: (1) 40-character ASCII display, (2) 64-character variable legend readouts, (3) CHECK STATUS/AUTODIAL indicators, and (4) sound feedback cues (i.e., keyclicks, beeps, rings). The ASCII characters sent by the Control Unit are displayed in a 5x7 dot matrix font. Function legends are part of an indexed data base within the Desk Unit.

4.2 Control Unit Software

The Control Unit consists of three modules -- System Monitor, Peripheral Interface Handler, and Desk Unit Handler. On power-up and initialization, the System Monitor displays date and time and attempts transmission of any pending SENDMAIL. This 'quiescent' state is maintained until the occurrence of an external event, at which time either the Peripheral Interface Handler or Desk Unit Handler is invoked. The Peripheral Interface Handler polls the devices -- MODEM, COUPLER, and ACR (Audio Cassette Recorder) -- to determine which device generated the interrupt and then "vectors" to the appropriate processing routine. The Desk Unit Handler module is dedicated to communication between Desk Unit and Control Unit. Figure 4-1 shows the functional block diagram of the Control Unit software. Figure 4-2 shows the System Monitor flow chart.

4.2.1 Function State Processing. The eight variable legend function keys provide the user with a menu of various MAILPHONE capabilities at each level in the functional hierarchy. At the top-most level are the major system functions. At all levels under each top level function, specific system capabilities and associated controls are associated with the eight variable legend function keys.

Function switch may perform all, some, or none of the following sequence of tasks in response to any function keypress:

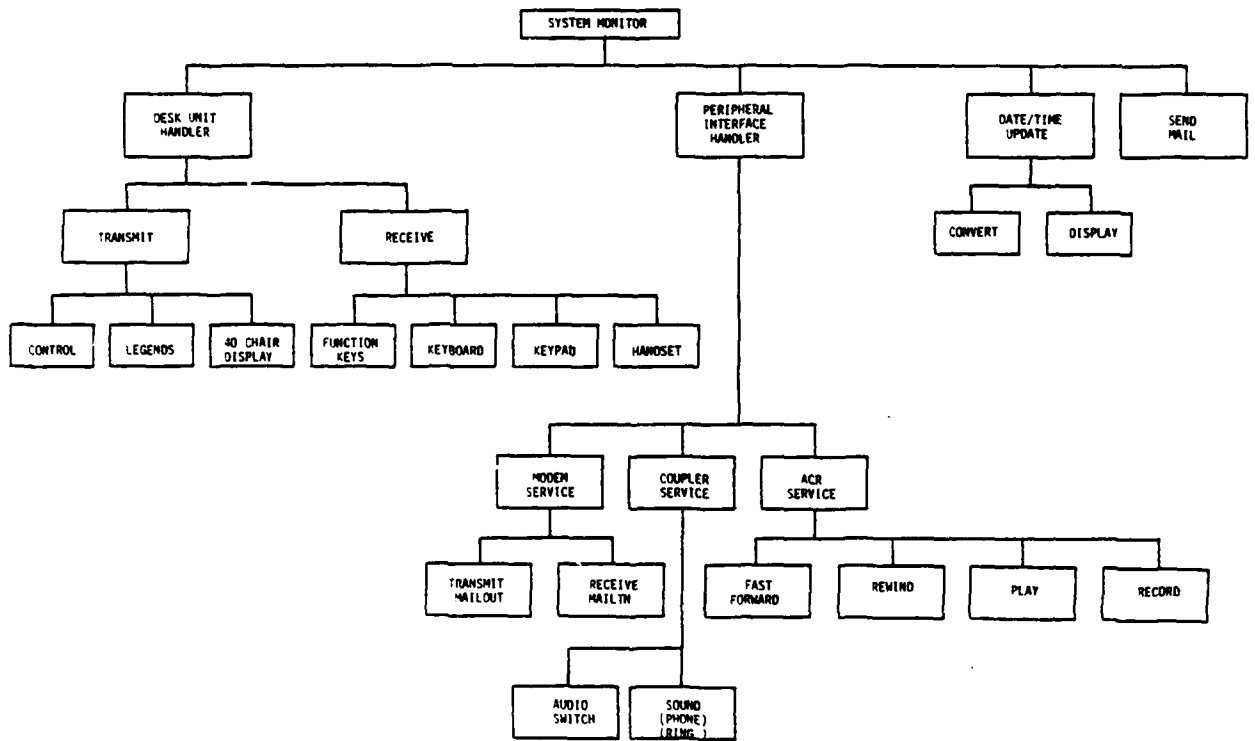

FIGURE 4-1.
CONTROL UNIT SOFTWARE FUNCTIONAL BLOCK DIAGRAM

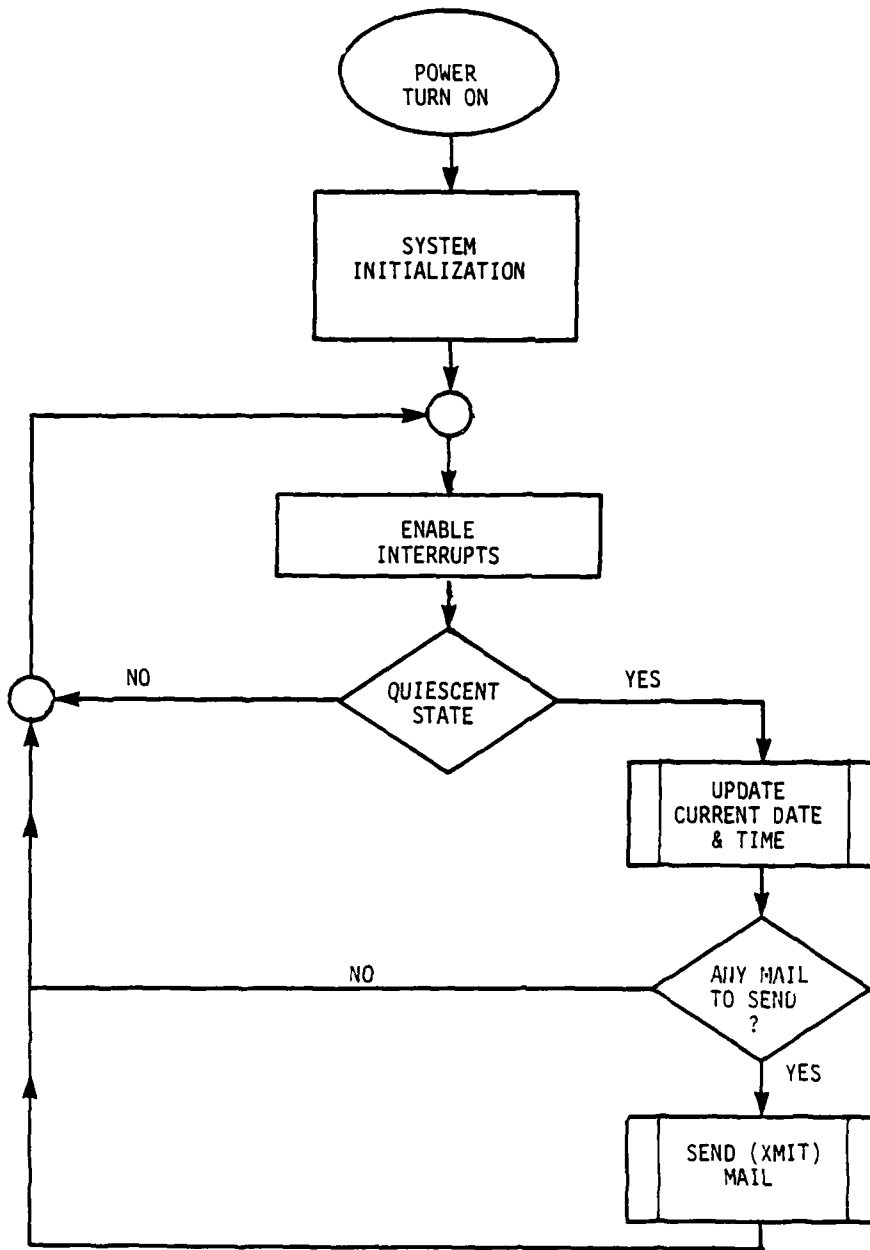

FIGURE 4-2.
SYSTEM MONITOR FUNCTIONAL FLOW CHART

- (1) Clear/update 40-character display.
- (2) Clear/update function legends.
- (3) Perform processing associated with the function switch pushed at the current level in the tree structure.
- (4) Indicate next default menu.
- (5) Invoke a new menu.

A Processing Level Descriptor Table (PLDT) of tasks and default menus for each level is maintained.

A set of state variables uniquely describing the state of the MAILPHONE system at any given time permits the selection of new, non-default menus; thus facilitating traversal of the MAILPHONE functional hierarchy. Figure 4-3 shows the data base content for the PLDT and Figure 4-4 shows a representative hierarchical data base structure for the hierarchical tree structure of "SENDMAIL."

4.2.2 Interface Management. The various Input/Output (I/O) devices used by the system include the following:

- (1) 100,000 Day Clock
- (2) Audio Switch.
- (3) Audio Cassette Recorder (ACR).
- (4) MODEM.
- (5) Coupler.
- (6) Printer.
- (7) Disk.
- (8) Desk Unit.

Each of these I/O devices require interface software and specific driver functions in order to perform their assigned functions. Each of these devices needs to be suitably initialized when power is first applied.

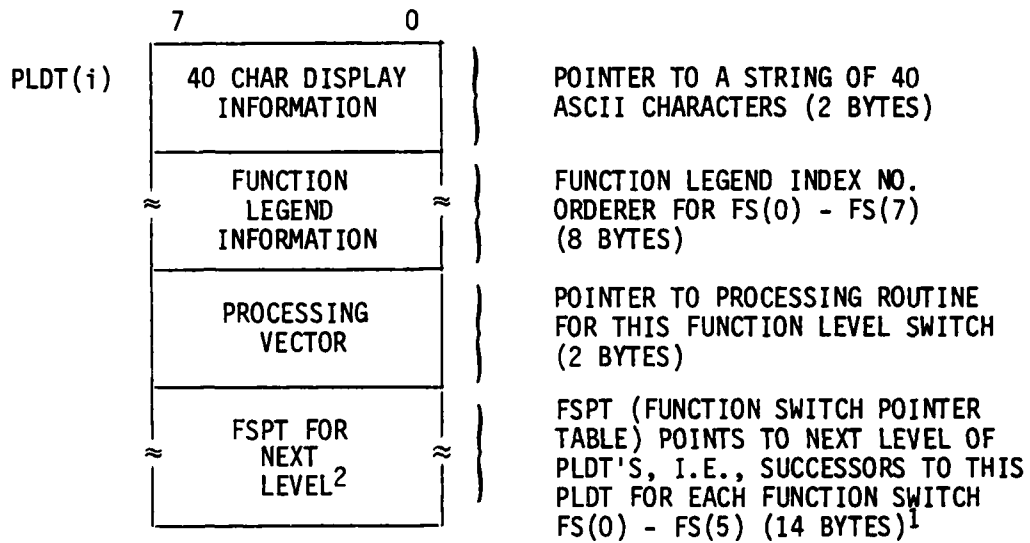

NOTE: ¹DATA BASE SIZE FOR EACH PROCESS = 26 BYTES.

²FSPT FOR NEXT LEVEL REQUIRES 7 ENTRIES IN THAT "CANCEL" FUNCTION SWITCH 7) NEED NEVER BE ALTERED FROM THE INITIAL FSPT.

FIGURE 4-3.
PROCESSING LEVEL DESCRIPTOR TABLE (PLDT) DATA BASE CONTENT

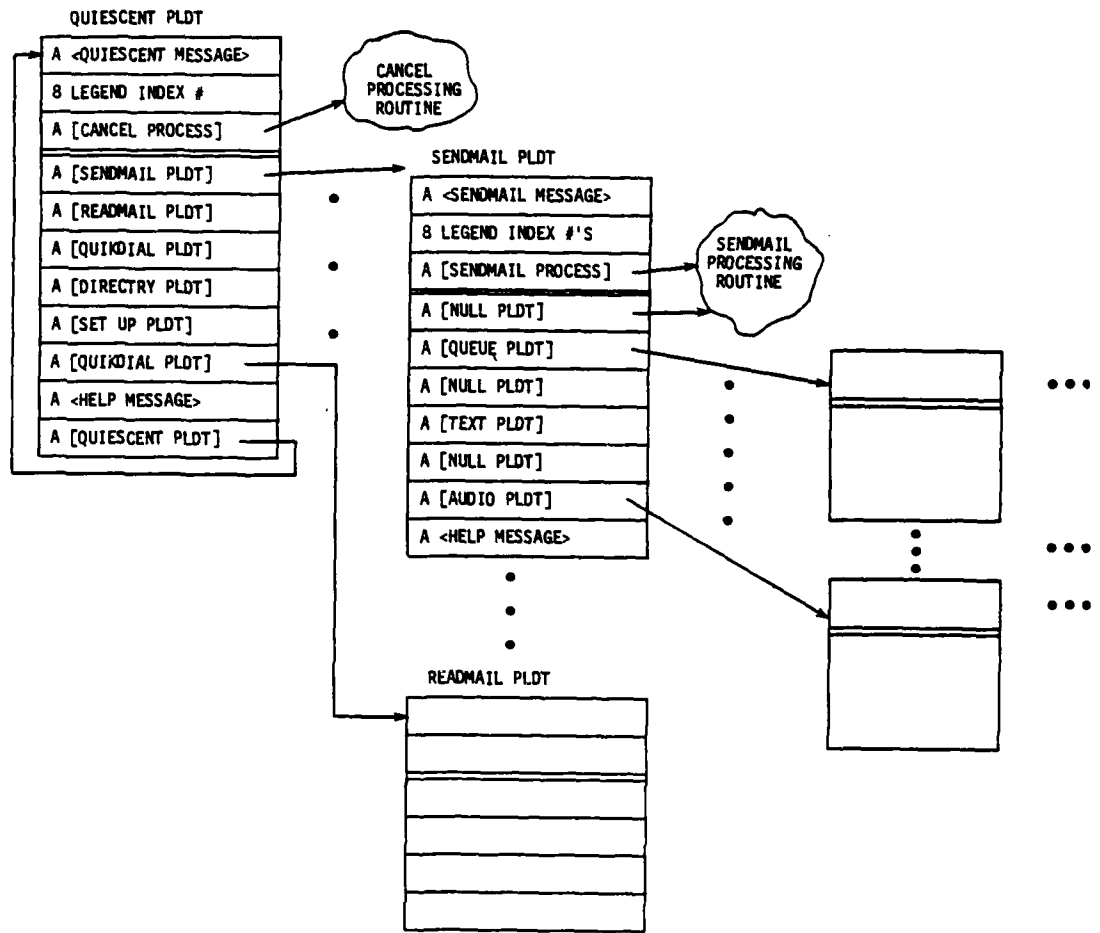

FIGURE 4-4.
FUNCTION SWITCH PROCESSING DATA BASE STRUCTURE

4.2.2.1 100,000 Day Clock. The 100,000 Day Clock provides date and time information for display in the quiescent state and for other timing functions required by the system. This device is initialized when the user inputs the current data and time under the DATE/TIME option under 'SET UP'. At all other times, this device is read by the software in the units defined in Table 3-6 and converted for display to month, day, hours, and minutes represented as ASCII characters.

4.2.2.2 Audio Switch. The Audio Switch is a hardware device used by the MAILPHONE system to route the audio signals between the system devices using audio signals (coupler, handset, and ACR). This device is controlled by software sending data to two output ports. The data sent to these ports opens or closes switches connecting the audio-related devices. Section 3.2.3 provides the specific details.

4.2.2.3 Audio Cassette Recorder (ACR). The ACR is used by the system to record and playback various audio messages. The ACR software is functionally partitioned into three functional modules: (1) interrupt service, (2) command processing, and (3) tape positioning.

The command processing function generates the commands to the ACR which are: (1) Play, (2) Record, (3) Fast Forward, (4) Rewind, and (5) Stop.

Once the ACR is commanded into motion, an interrupt is generated 18 times per revolution of the take-up spindle. This interrupt is processed by the ACR interrupt service function in order to maintain tape position location for tape file management. The tape positioning function is used to position the tape at the beginning of any 1-minute record gap.

4.2.2.4 MODEM. The MODEM is a hardware device used by the MAILPHONE system to transmit and receive text information. The MODEM software is partitioned into transmit processing and receive processing. The receive processing is entered when an outside telephone call is made to the MAILPHONE by another MAILPHONE. The "RING DETECT" from the MODEM results in a Control Unit interrupt and the MODEM receive processing is then executed.

The MODEM transmit processing is entered from the SEND MAIL function when messages are to be transmitted to another MAILPHONE. One ASCII character is sent at a time until the entire message has been transmitted.

4.2.2.5 Coupler. The Coupler is a device used to connect the Control Unit to a telephone line for the sending and receiving of "live" phone calls. The Coupler software is entered as a result of the "RING DETECT" interrupt when a live call is detected by the Coupler hardware. A "ring" is generated by the Coupler software at the Desk Unit for each "Ring Detect" interrupt received.

4.2.2.6 Printer. The printer is used by the MAILPHONE system as a hardcopy device for viewing both incoming and outgoing text mail on a 40 character per line format. When a hardcopy is requested (function switch selection), the Printer software outputs the message exactly as composed or received, character by character, until the full message has been output.

4.2.2.7 Disk. The Disk is used by the MAILPHONE system for the temporary storage of files containing messages received and messages to be transmitted. The Disk is also used as a non-volatile storage media for fixed data bases such as the Directory, ACR file management information, and a complete copy of MAILPHONE Control Unit executable software used at

power turn-on and for program overlays. Various file formats are used depending on the data structure to be stored or read from the disk. The software for reading and writing the Desk are called from various states of the Control Unit software depending on the user functional states. For instance, if a Directory has just been updated, it is written to the Disk replacing the old directory. If a text message has just been received, the message is recorded on the Disk until the user requests the contents of MAILIN messages.

4.2.3 Service Functions. A number of general service functions have been utilized in the development of the Control Unit software. These service functions are used at many levels of software and generally provide the software implementors a simpler interface in generating the system software. These service functions are listed below with a brief description of the task they perform:

- (1) Tape Position - positions the ACR tape at a given location.
- (2) 40-Character Display - outputs up to 40 characters to the Desk Unit display.
- (3) Legends - controls the Desk Unit for the generation of given function legend displays.
- (4) AUTODIAL/CHECK STATUS Light - controls the ON/OFF of both the AUTODIAL and CHECK STATUS L.E.D.'s.
- (5) Tape Availability - computes the next available location on tape for audio recording.
- (6) File Position - computes an index number for the next available file location for mail received and to be transmitted.
- (7) Dial - generates the electronic dialing sequence required for sending of mail and for normal telephone dialing.

4.2.4 Data Bases. A number of data bases are required by the Control Unit software in order to implement the MAILPHONE functional states. Not all of these data bases will be addressed here, only those that are required for the actual transmission and reception of electronic mail will be discussed. This also includes those data bases required to create, edit and view text messages and for the ACR tape format. Refer to Figure 4-5 for a pictorial representation of these data bases.

4.2.4.1 Directory. The directory is structured as a circular doubly linked list. Six breakpoints are associated with alphabetic categories under DIRECTORY option. Three structures are used for holding telephone numbers, mailphone numbers, and names. The first element of the directory data structure is a pointer to the beginning of a list of available entries. The Directory is kept as a file on disk. Entries are made into the Directory by the user from the Desk Unit keyboard when in the DIRECTORY-EDIT system state. These entries are used for directory phone number look-up when sending messages and autodialing.

4.2.4.2 SENDMAIL Header Buffer. The SENDMAIL Header Buffer is used for the creation of the necessary header information to transmit and receive MAILPHONE text and audio messages. The header contains the following information:

| <u>Data</u> | <u>Description</u> |
|------------------------------------|--|
| (1) Phone Index | Index number in the Directory for a phone number. |
| (2) Date and Time "SEND" Pushed | The date and time of message creation. |
| (3) Text/Audio | Indication of TEXT or AUDIO message associated with this header. |

(1) DIRECTORY

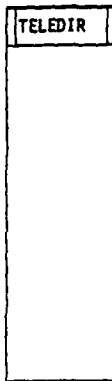
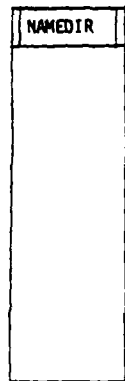

(2) MAILOUT HEADER BUFFER

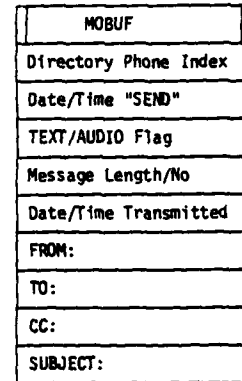

(3) TEXT GENERATION
BUFFER

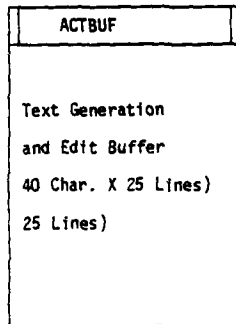

(4) MAILIN HEADER
BUFFER

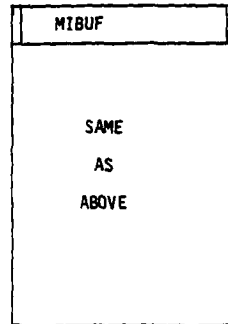

(5) TEXT TRANSMIT/
RECEIVE BUFFER

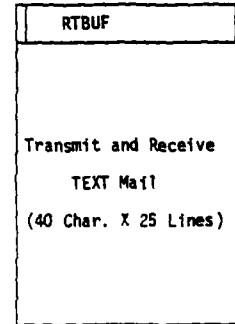

FIGURE 4-5.
REPRESENTATIVE SENDMAIL FUNCTION SWITCH DATA BASE STRUCTURE

- | | |
|-------------------------------|--|
| (4) Message Length | If the message is TEXT then this contains the number of characters in the text; if the message is audio, this contains the start position on tape for the message. |
| (5) Date and Time Transmitted | The date and time that the message was successfully transmitted to another MAILPHONE. |
| (6) FROM | Contains the user's name (20 ASCII characters). |
| (7) TO | Contains the entries for distribution. The names entered by the user here are compared against the Directory entries for validity. |
| (8) CC | Contains the names for distribution to receive a Carbon Copy. |
| (9) SUBJECT | Contains the user entry for the "SUBJECT" of this message. |

The data entered from the keyboard in the generation of a message header by the user is stored directly to, and displayed from, this buffer (TO, CC, SUBJ, FROM). All of the data contained in the header is stored on a disk file for subsequent transmission.

4.2.4.3 Text Generation Buffer. The Text Generation buffer is used as the actual working area for the composition and editing of TEXT messages. This buffer is represented to the user as a 40-character by 25-line message area and each line of the buffer can be viewed by the user using keyboard control characters. ASCII characters, entered at the keyboard are sent to the Control Unit from the Desk Unit and entered directly into this buffer. The Text Generation Buffer is stored in its entirety on a disk file for subsequent transmission.

4.2.4.4 READMAIL Header Buffer. The READMAIL Header Buffer is used for the actual transmission of the header information created in the SENDMAIL Header Buffer. This allows for the creation of new messages while transmitting messages already created. Additionally, the READMAIL Header Buffer is used for the reception of header information from other MAILPHONES since both transmission and reception of messages can not occur simultaneously. All header information received is filed on disk for subsequent display when requested by the user under READMAIL.

4.2.4.5 Text Transmission and Receiving Buffer. The Text Transmission and Receiving Buffer is used for the actual transmission and receiving of TEXT messages to and from other MAILPHONES. Text data to be transmitted is read from a disk file to this buffer and then transmitted. Likewise, received TEXT messages are stored, character by character, in this buffer until the full message is received. The TEXT data received in this buffer is filed on disk for subsequent display to the user when requested.

4.2.5 MAILPHONE To MAILPHONE Message Protocol. The MAILPHONE to MAILPHONE message protocol is a set of rules that are followed by the MAILPHONE Control Units when interconnected by telephone lines for the transmission and receiving of TEXT and AUDIO messages. The basic functions of the Control Unit software in implementing the protocol are to:

- (1) Establish and terminate a telephone line connection between two MAILPHONE units.
- (2) Assure message integrity through error detection, requests for retransmission and positive or negative acknowledgements.

These functions are performed by the MAILPHONE Control Unit software ("SEND/RECEIVE MAIL") as defined in Figure 4-6. The left half of the figure represents the "TRANSMITTER" MAILPHONE while the right side is the "RECEIVER" MAILPHONE. The items listed 1 through 10 indicate what function the TRANSMITTER is performing and at the same time, with the corresponding item number, what function the RECEIVER is performing.

The first level of protocol is to establish the connection between the MAILPHONES. This is accomplished by the automatic dialing by the "TRANSMITTER." When the dial is complete, a "RING DETECT" interrupt is generated by the RECEIVER MODEM and the RECEIVER unit goes "OFF-HOOK." This is detected by the "TRANSMITTER" MODEM from the "CARRIER DETECT" bit of the MODEM status word. At this time, the "TRANSMITTER" software sends the ASCII control character "ENQ" (enquire) to establish the first level of "handshake" with the "RECEIVER." The "RECEIVER" responds by sending back to the "TRANSMITTER" the ASCII control character "ACK" (acknowledge). The "TRANSMITTER" now knows that the "RECEIVER" is "on-line" functioning properly. The "TRANSMITTER" then sends the message header information (see DATA BASE section for the Control Unit) one ASCII character at a time at a rate of 300 baud. As each character of the header is transmitted both the "TRANSMITTER" software and "RECEIVER" software compute a checksum by adding each of the characters in the header. At the completion of sending the header, the "TRANSMITTER" sends the two byte (16 bits) accumulated checksum and the "RECEIVER" then compares this value with its own computed checksum as characters were being sent. If the checksums do not compare, then the "RECEIVER" sends the ASCII control character "NAK" (negative acknowledge) and both the "TRANSMITTER" and "RECEIVER" return to step 2 of Figure 4-6 for another attempt at sending the "header" information. Three attempts are made at sending the header, and if all result in "NAK" from the "RECEIVER" as a result of an incorrect checksum comparison, then both "TRANSMITTER" and "RECEIVER" exit the

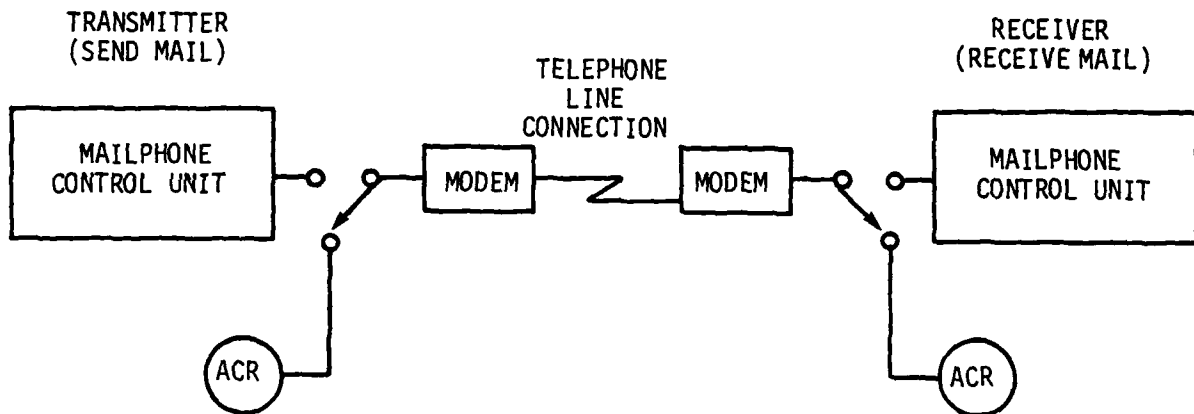

TRANSMITTER FUNCTIONAL STEPS

1. DIAL PHONE NUMBER (5 Rings Max)
2. SEND "ENQ"
3. WAIT "ACK"
4. SEND MESSAGE HEADER & CHECKSUM
5. WAIT "ACK/NAK" (ACK=6, NAK=2)
5. SEND "STX"
7. WAIT "ACK/NAK" (ACK=8, NAK=EXIT)

TEXT

8. SEND TEXT & CHECKSUM
9. WAIT "ACK/NAK" (ACK=10, NAK=6)
10. EXIT

AUDIO

8. SEND AUDIO
9. WAIT "CARRIER"
10. EXIT

RECEIVER FUNCTIONAL STEPS

1. MODEM INTERRUPT (CARRIER DETECT)
2. WAIT "ENQ"
3. SEND "ACK"
4. RECEIVER HEADER (COMPUTE CHECKSUM)
5. SEND "ACK/NAK" (ACK=6, NAK=2)
6. WAIT "STX"
7. SEND "ACK/NAK"

TEXT

8. RECEIVE TEXT (COMPUTE CHECKSUM)
9. SEND "ACK/NAK" (ACK=10, NAK=6)
10. EXIT

AUDIO

8. RECEIVE AUDIO (1 MINUTE)
9. SEND "CARRIER"

FIGURE 4-6.
SEND/RECEIVE MAIL FUNCTIONAL PROTOCOL FLOW DIAGRAM

processing. An attempt to redial is started by the "TRANSMITTER" 8 seconds later if no other outgoing messages are pending. When the checksums do compare (ACK from the "RECEIVER"), then the "TRANSMITTER" sends the ASCII control character "STX" (start of text). If the header information indicates a "TEXT" message then the "RECEIVER" immediately responds with the control character "ACK," but if the message is "AUDIO," the "RECEIVER" checks for an ACR tape location for the recording, positions the tape to that position, and then sends "ACK" to the "TRANSMITTER." If no tape segment is available, then the "RECEIVER" sends the "NAK" and both the "RECEIVER" and "TRANSMITTER" go "off-line" and EXIT the functions. For a "TEXT" message the "TRANSMITTER" sends the TEXT characters and computes a checksum with that sent from the "TRANSMITTER" and responds with either the "ACK" or "NAK ASCII control characters, depending on a valid compare. The "NAK" ASCII results in both the "TRANSMITTER" and "RECEIVER" attempting a "TEXT" message retransmission starting at step 6 in Figure 4-6. Again, three attempts are made before going "off-line." For an "AUDIO" message there is no checksum computation (audio information) and after 1 minute of recording, the "RECEIVER" always responds by putting the carrier signal back on the line at which time both "TRANSMITTER" and "RECEIVER" go "off-line." Figure 4-7 shows a time line representation of "TEXT" and "AUDIO" message block information and protocol.

A. TEXT MESSAGE

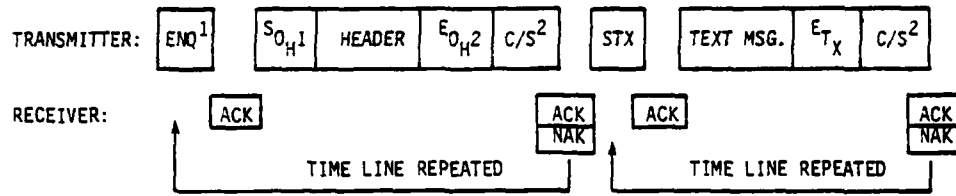

B. AUDIO MESSAGE

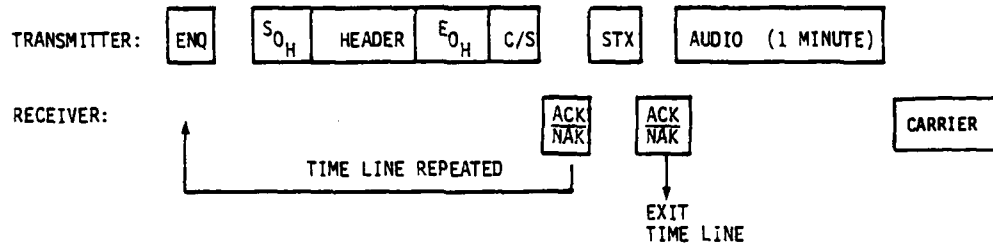

- NOTES: ¹ASCII CONTROL CHARACTERS
 ENQ = ENQUIRY
 SOH = START OF HEADER
 EOH = END OF HEADER
 ACK = ACKNOWLEDGE
 NAK = NEGATIVE ACKNOWLEDGE
 STX = START OF TEXT
 ETX = END OF TEXT
²C/S = CHECKSUM

FIGURE 4-7.
 TEXT/AUDIO MESSAGE BLOCK FORMAT AND PROTOCOL TIME LINE

5. SUMMARY

At the time of writing this report, three desk units have been completely fabricated. The MAILPHONE has been successfully demonstrated in Washington and all pertinent review comments incorporated. The demonstration, which consisted of prototype MAILPHONE systems communicating with each other, was given at DARPA's Cybernetic Technology Division office. These systems featured: (1) text message composition, modification, transmission, reception (storage), review and print; (2) audio message recording, rerecording (correction), transmission, reception and playback; (3) normal phone operations; and (4) executive phone functions, i.e., on-line directory, fast-dialing and redial of last unsuccessfully attempted number.

The physical appearance of the Desk Unit is both aesthetically pleasing and familiar. The Desk Unit looks like a GTE telephone with a more elaborate face plate. It is worth recalling that the single line display was primarily selected because its selection was in keeping with the MAILPHONE's telephone-like (and not a computer terminal-like) appearance. However, this selection potentially made other MMR problems rather difficult to overcome. For instance, it is difficult to create clear, concise unambiguous prompts with a single-line 40-character display especially if the prompt was geared to making a menu selection. It is in instances like these that the variable legend functions keys were found to be most useful. Devoting the top six L.E.D readouts associated with these keys to display the menu choices and the single line 40-character display to provide clarifying prompts virtually "opened up" the single-line display into a multi-line display! It became possible to pose questions or make clarifying comments with some semblance of personality. It may be argued that a single line display used in Times Square mode or Saccadic Scroll mode could display multiple lines. How-

ever, it is worth noting that the prompts would disappear from view in each of these instances (often sooner than the user might like them to!). This undesirable feature associated with the latter implementation can potentially burden the user and detract from the congenial MMR of the MAILPHONE system.

The display mode study provided some interesting results. These results reinforced and validated our belief that Saccadic Scroll is superior to Times Square text presentation for both reading and comprehension. It was gratifying to see that our selection of the Hewlett Packard HDSP-2001 yellow L.E.D.'s lived up to expectation. The characters are both crisp and easy to read. The "beep" that accompanies the refreshing of the display in response to user action is both reassuring and pleasant.

The single-line text generator is neither an elaborate word-processor nor a cumbersome command-oriented editor. Rather, it is a display-oriented cursor-cued text editor designed for both ease of use and compatibility with the underlying capabilities of the keyboard. The membrane keyboard layout and compact size do not in any way detract from its functionality. The 'click' feedback associated with each keypress on the keyboard has a very positive feel. The key pressure empirically determined to be around 3-4 psi is just right. However, the key pressure required increases with use. For this reason, it was decided that the membrane technology-based keyboards should be replaced with conventional keyboards in the future. Appropriate visual and audible feedback that occur in response to user-initiated or system-initiated action are helpful, attention-getting, and above all, friendly.

6. REFERENCES

- Cuff, R.N. On Casual Users, *Int. J. Man-Machine Studies* (1980), 12, 163-187.
- Martin, J. (1973) *Design of Man-Computer Dialogues*. Englewood Cliffs. New Jersey: Prentice-Hall.
- Parsons, H. McI. (1972) *Man-Machine System Experiments*, Baltimore: John Hopkins Press.
- Sekey, A. Comparative Study of "Times Square" and Saccadic Scrolling Text Display Methods, Final Report, Computer Systems Laboratory, U.C. Santa Barbara, Submitted to A. Madni, Perceptronics, 1980.
- Freedy, A., Weltman, G., and Lyman, J. Interactive Aspects of a Man/Learning System Control Team. In *Proceedings of 1972 International Conference on Cybernetics and Society*, IEEE Systems, Man, Cybernetics Society, 1972.

APPENDIX A

MAILPHONE DESK UNIT/CONTROL UNIT INTERFACE DESIGN AND PROTOCOL

The main user interface to the MAILPHONE is via the desk unit. Information must pass from the desk unit informing the control unit of various requests made by the user and likewise, the control unit must pass information to the desk unit, to indicate to the user, various states of the system in the form of displays and sounds. The objective of the design given below is to minimize the amount of data on the interface, allowing for maximum processing time in both the desk unit and control unit with minimum error from the interface.

The data/information from the desk unit required by the control unit is in the form of a:

- (a) Keyboard entry (ASCII character).
- (b) Function switch indication.
- (c) Handset switch indication.
- (d) Numeric pad entry.
- (e) Desk Unit error indications.

Since there are different types of information being passed from the desk unit, a way of distinguishing these types is indicated to the control unit via the most significant bit (MSB) of the word being sent. Defined below is the format for the data/information from the Desk Unit to the Control Unit.

Desk Unit to Control Unit Interface Data Formats

MSB

76543210

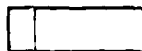

Control bit = 0 → bits 0-6 define the keyboard ASCII character
1 → bits 0-6 encoded as follows:

0-7 defines which function switch pushed
8 defines keypad switch release
9-6H define desk unit error codes
21-22H define handset ON/OFF hook, respectively
30H-39H define the keypad numerical entries 0-9
2AH defines the keypad entry "*"
39H-7F unused

The data/information from the control unit to the desk unit is in the form of:

- (a) 40 character display information.
- (b) 64 character display information (function legends).
- (c) Control information for:
 - . cursor position for 40/64 character displays.
 - . STATUS/AUTODIAL lights.
 - . sound generation.

Again, due to the different types of information being sent from the control unit to the desk unit, control characters are required to indicate to the desk unit which of the above given types of information is being sent. The available control characters must fall outside the range of displayable ASCII codes. Thus, control information and data from the control unit to the desk unit is as given below.

Control Unit to Desk Unit Interface Data Formats

1. Display Mode Word

76543210

0000001

→ 0 = 40 character display

1 = 64 character display

This control word is always followed by a second word, the first (as shown) defines which of the 8 function legends is to be written to, and the second word defines an index into a set of precanned legends to be displayed at the function legend location defined by the control word.

4. Cursor Control Word

76543210

| | |
|------|--|
| 0001 | |
|------|--|

This control word is used for cursor control for the current display mode (40/64 character). Bits 0-3 are encoded for the following functions:

- 0000 - no cursor display (position maintained)
- 0001 - display cursor*
- 0010 - home cursor
- 0011 - move cursor one position left
- 0100 - move cursor one position right
- 0101 - rubout at current cursor position where all characters to the right of the cursor are repositioned one character to the left, e.g., display before rubout - ABCDE, display after rubout - ABDE
- 0110 - insert at cursor position where all characters to the right of the cursor and at the cursor position move one character to the right, e.g., before insert command - ABCDE, insert command followed by ASCII character "F" - ABFDE

This command will stay in effect at the current display until reset by another cursor command.

- 0111 - clear display and home cursor

*The cursor is displayed by alternating (at a 2 hertz rate) the 5X7 dot matrix character position between the character represented at that position and all dots (35) lighted.

APPENDIX B

DATA SHEETS FOR 100,000 DAY CLOCK,
AUDIO CASSETTE RECORDER, MODEM, POWER SUPPLY

100,000 DAY CLOCK

OPERATING MANUAL

© 1978 by MOUNTAIN HARDWARE, INC.

INTRODUCTION

Mountain Hardware's 100,000 Day Clock is an accurate time piece for your computer. It will keep track of time in 100 microsecond intervals, up to 100,000 days. Advanced Complimentary Metal Oxide Semiconductor (CMOS) circuit draws less than 2 mA, which allows the clock to be run off a 9-volt battery for up to four days while the computer is shut down or if AC power fails.

The Clock uses 15 I/O ports for the time plus one I/O port to set the interrupt function. Using DIP switches, the user can assign these ports to any 16 consecutive 8080/Z-80 ports. The Clock is easily set by entering BCD digits one at a time at each time port. The moment you enter the first digit, the Clock stops. Then you enter the remaining digits. The Clock starts again on the first "read" command. A "write protect" switch prevents the Clock from being accidentally stopped or changed.

By using the interrupt feature of the Clock, activities relating to time of day may be preformed at preprogrammed intervals without interfering with the normal operations of the computer. You may program interruptions on any change in a Clock digit; that is, at intervals of 100 microseconds, 1ms, 10ms, and so on to 1 hour, 10 hours, etc. The board can be easily used with most BASICs. However, with our Intro1 BASIC, time is especially simple to set, compare, check, display and print.

Two software packages are included that expand the capabilities of the Clock board. One package gives calendar information such as month, day, year and day of week. The other package allows multiple interrupts, at any time interval, or absolute time.

The 100,000 Day Clock board, because of all the features included on one board, will enhance the power of your computer and add to it the dimension of time.

USING THE CLOCK

The 100,000 Day Clock has been designed to work in virtually all S-100 computers. It will work with machines running at speeds up to 4 MHz, which means it will operate with the newer and faster microprocessors.

When handling the clock board, care must be taken to avoid static discharges on the board, as this can cause damage to the CMOS (Complimentary Metal Oxide Semiconductor) circuitry. Hold the board on the sides when handling, and store the unit on static-proof foam when out of the computer. CMOS has very high input impedances and properly placed fingers on the back side of the board can stop the clock or accidentally change the time. General rule is to handle as little as possible, and then only on the sides.

BATTERY INFORMATION

The battery supplied with the clock board is a rechargeable NiCad battery that powers the clock when the computer is turned off, or when the power fails. The battery will continue to power the CMOS circuitry on the board and the correct time will not be lost. The battery has the capacity to run the clock for 4-5 days if it is fully charged.

To fully charge the battery, power must be applied to the clock for at least 4 days; as it is a slow charge. This is designed to maximize the life of the battery. As a general guideline with plenty of margin, let the battery charge two hours for every hour of use.

When the computer power is turned off, the board may be removed from the computer as long as the battery is in place and charged. The clock will continue keeping time. Hence, the board may be "time-shared" between two computers or set aside for awhile if its space is needed for another peripheral in machines with few expansion slots.

The battery's life should be several years and should be replaced if its performance drops significantly.

A 9 - 12 volt adapter may be plugged into J1. This will keep the battery charged and the clock running even when power is turned off from the computer. This will allow very long down times, and also keep the battery charged in the event power should go off in the building.

The adapters are available from Mountain Hardware.

AD-A105 618

PERCEPTRONICS INC WOODLAND HILLS CA

F/G 17/2

MAILPHONE: A DEMONSTRATION OF MAN-MACHINE-RELATIONS IN ELECTRON--ETC(U)

JUN 81 A MADNI, G WELTMAN

N00014-80-C-0755

UNCLASSIFIED

PFTR-1094-81-6

NL

1 of 2
AD-A105 618



END
DATE
FILMED
11 81
DTIC

```

40A2 C1          POP      B
40A3 C9          RET

      ;; STOP TASK IN A REG.
40A4 CD9440     KILTSK: CALL  GETADR
40A7 3600       MVI      M,0
40A9 C9          RET

      ;; START TASK IN A REG.
40AA CD9440     LIVTSK: CALL  GETADR
40AD 3601       MVI      M,1
40AF C9          RET

      ;; SET ALL TASKS TO A (RUN/STOP)
40B0 21F140     SETALL: LXI    H,TSKTBL
40B3 E601       ANI      1
40B5 46         MOV      B,M
40B6 04         INR     B
40B7 23         INX     H
40B8 23         INX     H
40B9 110C00     SETAL2: LXI    D,12
40BC 77         MOV      M,A
40BD 19         DAD     D
40BE 05         DCR     B
40BF C2BC40     JNZ     SETAL2
40C2 C9          RET

      ;; SET A TASK TO A (RUN/STOP)
40C3 CD9440     SETTSK: CALL  GETADR
40C6 3600       MVI      M,0
40C8 23         INX     H
40C9 70         MOV      M,B
40CA 010A00     LXI    B,10
40CD 09         DAD     B
40CE D1         POP     D
40CF 3E03       MVI      A,3
40D1 C1         SETTS2: POP  B
40D2 70         MOV      M,B
40D3 2B         DCX     H
40D4 71         MOV      M,C
40D5 2B         DCX     H
40D6 3D         DCR     A
40D7 C2D140     JNZ     SETTS2
40DA EB         XCHG
40DB E9         PCHL

      ;; ENABLE SOFTWARE CONTROL
40DC 21F240     ONJOB: LXI    H,TSKTBL+1
40DF 3601       MVI      M,1
40E1 C9          RET

      ;; DISABLE SOFTWARE CONTROL
40E2 21F240     OFFJOB: LXI   H,TSKTBL+1
40E5 3600       MVI      M,0
40E7 C9          RET

      ;; SET MASTER ENABLE/DISABLE TO A
40E8 E601       RUNSTP: ANI   1
40EA 32F240     STA     TSKTBL+1

```

```

40ED C9          RET
40EE          NUMBER: DS      1
40EF          TSKPTR: DS      2
40F1          TSKTBL: DS     256
41F1 =         LASTLOC EQU   $

```

A>

THEORY OF OPERATION

The S-100 Clock communicates to the central processor through a block of 16 I/O ports. The address of this block is determined by the setting of S1 switches 2 through 5. These select the high order 4 bits of the eight-bit I/O address for each of the 16 ports.

The block address of each port, 0 through 15, corresponds to the address of a location in the 16X4 RAM at U29. Locations 0 through 14 of this RAM each hold one of the 4-bit BCD digits of the current time. The contents are as follows:

| | | | |
|-----|----|-----|---------------------------|
| Loc | 0 | 0-9 | Hundreds of microseconds. |
| | 1 | 0-9 | Milliseconds. |
| | 2 | 0-9 | Tens of milliseconds. |
| | 3 | 0-9 | Hundreds of milliseconds. |
| | 4 | 0-9 | Seconds. |
| | 5 | 0-5 | Tens of seconds. |
| | 6 | 0-9 | Minutes. |
| | 7 | 0-5 | Tens of minutes. |
| | 8 | 0-9 | if Loc 9=0 or Loc 9=1 |
| | | 0-3 | if Loc 9=2, Hours. |
| | 9 | 0-2 | Tens of hours. |
| | 10 | 0-9 | Days. |
| | 11 | 0-9 | Tens of days. |
| | 12 | 0-9 | Hundreds of days. |
| | 13 | 0-9 | Thousands of days. |
| | 14 | 0-9 | Ten-thousands of days. |
| | 15 | | Used for interrupts. |

Thus, an input operation to block address 4 will return the current number of seconds in the lower four bits of A. The information in U29 is updated by the clock every 100 microseconds. A full clock read requires 15 input operations. Since it is possible for a clock tick (update) to occur between two of the input operations, a flag is included with the data to resolve any ambiguity. If the most significant bit of A comes back set after a clock input, then the clock has not ticked since the previous input.

The clock is set by output operations to the addresses of the time digits in the block of ports. S1 (Switch 1) must be closed to write enable the clock. Outputs to block addresses 0-14 cause the lower 4 bits of the AC to be written to the corresponding digit address in U29 and STOP THE CLOCK. The clock remains stopped until the processor reads any of the time digits. The clock will then tick 100 microseconds later and continue to update every 100 microseconds.

FIXED SPEED PHI-DECK MODEL #1

SPECIFICATIONS

| | |
|---|---|
| <u>POWER REQUIREMENT:</u> | +12V \pm .2V at 1.5 amps -12V \pm .2V at 100 mA |
| <u>RECORDING DENSITY:</u> | Up to 1600 FRPI (Flux Reversals Per Inch) |
| <u>DATA CAPACITY (at 1600 FRPI):</u> | 5.76 M flux reversals per track per 300 ft. cassette |
| <u>ENCODING METHODS (user provided):</u> | Most any saturated recording technique (RB, CRB, NRZ, NRZ1, PM, etc.) |
| <u>DATA INTERFACE LOGIC:</u> | TTL |
| <u>CASSETTE TYPE:</u> | Certified data cassette |
| <u>CONTROLS:</u> | Threshold, Gain |
| <u>FUNCTIONS:</u> | Play/record, stop, fast forward, and rewind |
| <u>PLAY SPEEDS:</u> | 5 ips dc, 10 ips ac |
| <u>WOW AND FLUTTER:</u> | Less than .25% wrms |
| <u>FAST FORWARD OR REWIND TIME:</u> | Less than 35 seconds for C-60 cassette |
| <u>DRIVE SYSTEM:</u> | Capstan drive with dc motor, belt, and flywheel (ac motor optional) |
| <u>REEL SYSTEM:</u> | DC shielded motor for each reel |
| <u>HEAD AND PINCH ROLLER ENGAGE/DISENGAGE SYSTEM:</u> | DC motor |
| <u>OPERATING POSITION:</u> | Any position, horizontal to vertical |
| <u>HEADBAR ENGAGE TIME:</u> | Less than 120 ms |
| <u>HEADBAR DISENGAGE TIME:</u> | Less than 120 ms |
| <u>DIMENSIONS:</u> | See page 17 |

* Specification subject to change without notice.

FIXED SPEED DECK & MOTION CONTROL BOARD FUNCTION AND INTERFACE DIAGRAM

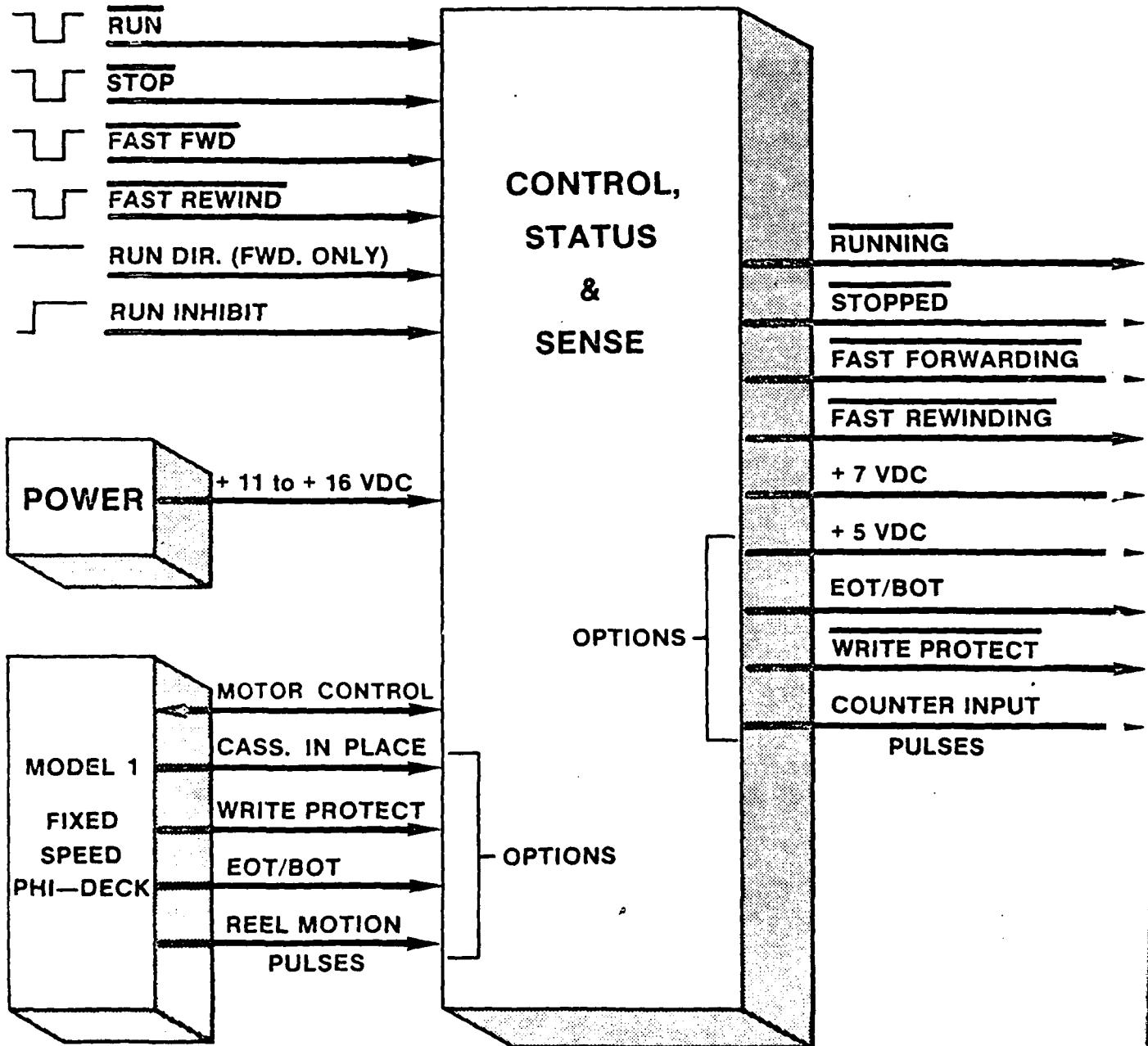

With the exception of the speed control line, all non-optional input and output lines are DTL-TTL and CMOS compatible. Optional lines are either DTL-TTL and CMOS compatible logic signals or analog signals.

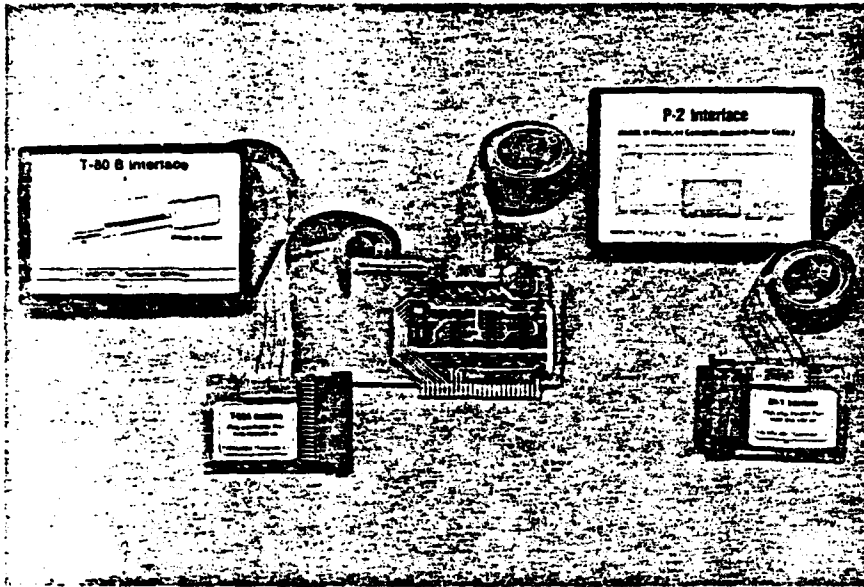

Left to right: Trendcom interfaces for TRS-80 (with and without Expansion Interface), Apple II, PET, and Sorcerer.*

INTERFACING

Interfacing the Trendcom 200 is easy. The TTL-compatible input will work with the eight-bit parallel ports of many microcomputers. For the non-technical computerist, Trendcom offers "plug in and go" interface modules for the most popular microcomputers.

TRS-80: The T-80A is an interface cable for the TRS-80 user with Expansion Interface. The T-80B plugs directly into the TRS-80 and both modules recognize the Level II LLIST and LPRINT commands.

Apple II: The A-II interface plugs into any slot in the Apple and incorporates print driver routines in ROM for the usual PR#n commands. An optional version, A-II.G, will incorporate additional firmware to allow printing Apple's Hi-Res data simply by Basic language CALL's.

PET: The P-2 interface connects to the PET's IEEE 488 connector as

Device 4 and is compatible with PET's CMD and OPEN commands. A through connector is provided to allow connecting other IEEE peripherals.

Sorcerer: The SR-1 interface cable allows direct connection to the Sorcerer's parallel printer port.

For serial communications, an RS-232 interface will be introduced in late 1979 to provide EIA level conversion and serial-to-parallel conversion.

ORDERING INFORMATION

The Trendcom 200, Interfaces, and Paper are available from Trendcom dealers throughout the U.S. and most European countries. Contact Trendcom for the address of a nearby dealer.

Trendcom 200 Specifications

TEXT

Format 80 characters per eight inch line
6 lines per inch nominal

Print speed 40 characters per second

Line Feed 50 milliseconds nominal

Character Set 96 characters, including upper and lower case, numerals, and symbols.

GRAPHICS

Format 480 seven-dot print positions per line

Print Speed 240 print positions per second

Control Codes Hex 9E clears buffer, causes line feed and carriage return, and starts graphics mode.
Hex 9F clears buffer, causes carriage return, and starts text mode.

COMMON

Interface Parallel TTL-compatible via 20-pin "ribbon cable" type connector. Eight data lines. Strobe input and Busy output. Printer does not accept data while last line is printing.

Paper 8½ inch wide thermal paper, available from Trendcom dealers in 85 foot rolls, black image on white.

Power 115 VAC, 60 Hz, 20 watts (230 VAC and 50 Hz available)

Dimensions 12½"W x 10"D x 2¾"H (31.7cm x 25.4cm x 7cm)

Weight 8 lbs (3.6 kg).

Specifications subject to change without notice.

available from:

*TRS 80 is a trademark of Tandy Corporation
Apple II is a trademark of Apple Computer, Inc.
PET is a trademark of Commodore Business Machines, Inc.
Sorcerer is a trademark of Exidy Corporation.

60 WATT SINGLE OUTPUT SWITCHERS



PC BOARD



OPEN FRAME

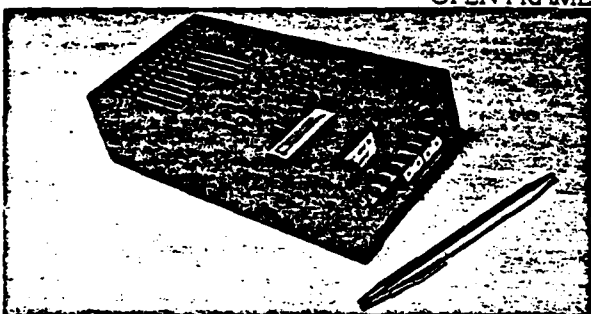

ENCLOSED UNIT

GENERAL DESCRIPTION

The 1060 Series Switching Power Supplies offers a major breakthrough in switcher design. Utilizing a proprietary conversion technique, these supplies feature high efficiency, small size, low cost, and can be purchased either as an open frame, single PC board or enclosed unit.

The supplies produce an output of 60 watts in a variety of output voltages and currents with efficiencies in excess of 75%.

By using computer grade state-of-the-art integrated circuits and discrete components, the parts count has considerably decreased as compared to older designs, thus enhancing reliability and performance. All components are carefully selected and derated to at least a minimum of 50% of their maximum ratings, for a long, reliable and trouble-free performance.

Price has also been kept low, and Power General's dollars per watt figure is one of the lowest in the industry.

| PRICING (SINGLE UNIT) | | |
|-----------------------|---------------|-------|
| MODEL 1060-xAx | PC BOARD | \$105 |
| MODEL 1060-xBx | OPEN FRAME | \$109 |
| MODEL 1060-xCx | ENCLOSED UNIT | \$117 |

TEL: (617) 828-6216
TWX: 710-348-0200

ORDERING INFORMATION

Example: 1060-1C2 depicts a power supply with output 5 VDC @ 12A, enclosed unit, factory wired for 230 VAC.

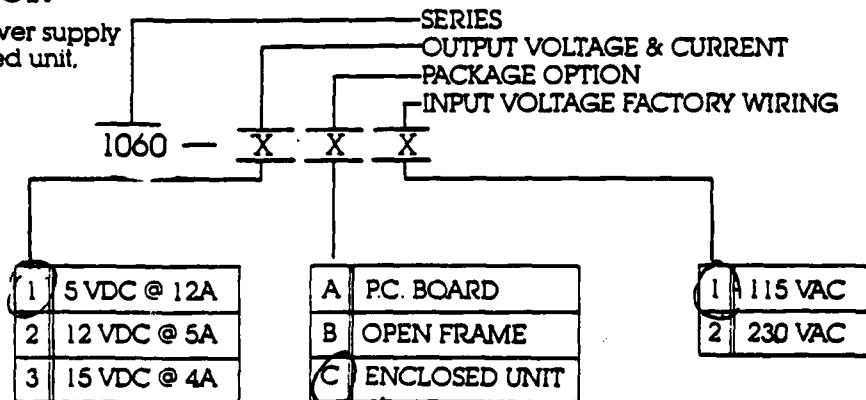

**POWER
GENERAL**

GENERAL SPECIFICATIONS

Electrical

- Efficiency 75% Nominal
- Input Voltage Range 90-130 Jumper Selectable
180-260 See page 27 for conversion information
- Input Voltage frequency Range 45 to 450 HZ
- Frequency of operation 20 KHZ nominal
- Output Voltages and Currents See ordering information.
- Line Regulation 0.1% over entire input range, all models
- Load Regulation 0.4% from no load to full load, all models.
- Low Frequency Hum 30 mV peak-to-peak typical, 120 HZ
- High Frequency Ripple 50 mV peak-to-peak 5 volt model
100 mV peak-to-peak for other models as measured at 30 MHZ BW.
- Ripple, Noise & Hum 10 mV RMS, typical
- Response time 200 μ sec to 1% for $\pm 25\%$ load change, with a max deviation of $\pm 3\%$
- Output Voltage Overshoot None at turn-on, turn-off or power failure
- Holdup time Output will hold-up for a minimum of 32 msec after loss of AC power, at nominal line and load for all models.
- Inhibit Standard on all models. Power supply will turn-off with TTL logic "1" and turn-on with TTL logic "0" applied to "INH" terminal provided on the PC board.
- Overvoltage protection Shut-down type OVP, standard on all models set at 130% of nominal output voltage, $\pm 5\%$. Other settings available upon request.
- Current limit Foldback current limiting with automatic recovery, protects both power supply and load.
- Output polarity Output is floating and may be referenced positive or negative, up to 500V off chassis ground.
- Isolation 1000 VAC
- Soft start Standard on all models, prevents output overshoots and power transformer saturation on turn-on.
- In-Rush Current Limiting Standard on all models keeps turn on current below 20A

• Remote Sensing

Standard on all models, compensates for cable voltage drops up to 5% of nominal output voltage. Outputs are also internally sensed, in case sense leads are accidentally opened. On-board, standard all models.

• Fusing

• RFI Filtering

Advanced high quality input line filter provides differential and single ended filtering of high frequency components down to acceptable levels. A three conductor input power cord is recommended.

Environmental

• Temperature Coefficient $\pm 0.02\%/^{\circ}\text{C}$

• Operating Temperature Range

Full output from 0°C to 50°C with natural convection. Derate output linearity 60% at 70°C .

(Note: External heatsink mounting is required for PC board units only)

• Storage Temperature

-55°C to $+85^{\circ}\text{C}$

Mechanical

• Input/Output Connections

AC input, sense terminals and DC output are provided through high quality, non-breakable barrier strip. See mechanical drawings for terminal designations.

• Open Frame Units

$\frac{1}{2}$ in. thick custom made aluminum extrusion angle, black anodized for better heat conduction, provides two surface mounting through threaded #8 stainless steel captive hardware.

• Enclosed Units

Perforated 0.04 in. thick aluminum black anodized cover, offers protection plus radiated EMI/RFI filtering.

• Printed Circuit Boards

Type FR4, glass epoxy fire retardant, on all units.

• Mechanical Specifications

See page 27

• Weight (Nominal)

Series 1060 { PC Board 1.1 lbs (0.50 kgs)
Open frame 1.6 lbs (0.72 kgs)
Enclosed Unit 2.2 lbs (1.0 kg)

