

AD-A105 767

BAKER (MICHAEL) JR INC BEAVER PA
NATIONAL DAM SAFETY PROGRAM. ARTHURS POND DAM (INVENTORY NUMBER--ETC(U)
JUN 81 6 KESTER

F/G 13/13

DACW51-81-C-0010

NL

UNCLASSIFIED

1 of 2

11 975



AD A 105767

3

LOWER HUDSON RIVER BASIN

ARTHURS POND DAM

LEVEL

ORANGE COUNTY, NEW YORK
INVENTORY NO. N.Y. 490

PHASE I INSPECTION REPORT
NATIONAL DAM SAFETY PROGRAM

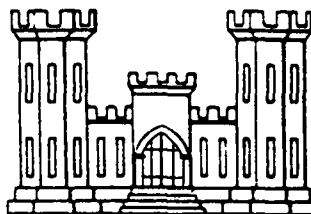

APPROVED FOR PUBLIC RELEASE;
DISTRIBUTION UNLIMITED

DTIC
ELECTE
OCT 19 1981
S D

NEW YORK DISTRICT CORPS OF ENGINEERS

JUNE 1981

10 10 19

REPORT DOCUMENTATION PAGE		READ INSTRUCTIONS BEFORE COMPLETING FORM
1. REPORT NUMBER	2. GOVT ACCESSION NO. AD-A405767	3. RECIPIENT'S CATALOG NUMBER 767
4. TITLE (and Subtitle) Phase I Inspection Report Arthurs Pond Dam Lower Hudson River Basin, Orange County, NY Inventory No. 490		5. TYPE OF REPORT & PERIOD COVERED Phase I Inspection Report National Dam Safety Program
7. AUTHOR(s) GRANVILLE KESTER, JR. <i>Kester, Jr.</i>		6. PERFORMING ORG. REPORT NUMBER
9. PERFORMING ORGANIZATION NAME AND ADDRESS Michael Baker, Jr. Inc. 4301 Dufch Ridge Road Box 280 Beaver, PA 15009		8. CONTRACT OR GRANT NUMBER(s) <i>(15) DACW51-81-C-0019</i>
11. CONTROLLING OFFICE NAME AND ADDRESS Department of the Army 26 Federal Plaza New York District, CoE New York, New York 10287		10. PROGRAM ELEMENT, PROJECT, TASK AREA & WORK UNIT NUMBERS <i>(12) 208</i>
14. MONITORING AGENCY NAME & ADDRESS (if different from Controlling Office) Department of the Army 26 Federal Plaza New York District, CoE New York, NY 10287		12. REPORT DATE <i>(11) 30 June 1981</i>
		13. NUMBER OF PAGES
16. DISTRIBUTION STATEMENT (of this Report) Approved for public release; Distribution unlimited.		15. SECURITY CLASS. (of this report) UNCLASSIFIED
17. DISTRIBUTION STATEMENT (of the abstract entered in Block 20, if different from Report) <i>(6)</i> National Dam Safety Program. Arthurs Pond Dam (Inventory Number NY 490), Lower Hudson River Basin, Orange County, New York. Phase I Inspection Report.		15a. DECLASSIFICATION/DOWNGRADING SCHEDULE
18. SUPPLEMENTARY NOTES		
19. KEY WORDS (Continue on reverse side if necessary and identify by block number) Dam Safety National Dam Safety Program Visual Inspection Hydrology, Structural Stability Arthurs Pond Dam Orange County Lower Hudson River Basin		
20. ABSTRACT (Continue on reverse side if necessary and identify by block number) This report provides information and analysis on the physical condition of the dam as of the report date. Information and analysis are based on visual inspection of the dam by the performing organization. Examination of available documents and a visual inspection of the dam and appurtenant structures did not reveal conditions which constitute an immediate hazard to human life or property.		

Using the Corps of Engineers screening criteria, it has been determined that the dam would be overtopped for all storms exceeding approximately 44 percent of the Probable Maximum Flood (PMF). The spillway is, therefore, adjudged as "seriously inadequate", and the dam is assessed as unsafe, non-emergency.

The classification of "unsafe" applied to a dam because of a "seriously inadequate spillway" is not meant to connote the same degree of emergency as would be associated with an "unsafe" classification applied for a structural deficiency. It does mean, however, that, based on an initial screening and preliminary computations, there appears to be a serious deficiency in spillway capacity, so that if a severe storm were to occur, overtopping and failure of the dam are likely to take place, significantly increasing the hazard to loss of life downstream.

On the basis of stability analyses of the masonry/concrete gravity portion of the dam performed for this investigation, the factors of safety against overturning are generally low, and the locations of the resultants fall outside of the middle 1/3. The safety factor of the dam against sliding was determined to be less than the recommended guidelines for all loading conditions.

It is therefore recommended that, within 3 months of notification of the owner, detailed hydrologic and hydraulic investigations of the structure should be undertaken to more accurately determine the site-specific characteristics of the watershed and their effects upon the overtopping potential of the dam. At the same time, further analyses of the structural stability of the overflow and nonoverflow sections should be performed. The results of these investigations and analyses will determine the appropriate remedial measures required to achieve a spillway capacity adequate to discharge the outflow from at least the 1/2 PMF. In the interim, a detailed emergency action plan must be developed and implemented during periods of unusually heavy precipitation. Also, around-the-clock surveillance must be provided during these periods.

Current inspection and maintenance procedures by the owner are adequate, but need to be documented. Monitoring of the reservoir levels should be expanded to include readings during peak flow periods. The cracks and construction joints in the concrete cap should be monitored for further deterioration. The dam should be examined for seeps when the reservoir level is at normal pool.

Accession For
 NIS CAAM
 DTIC TAB
 Unannounced
 Justification

By _____
 Distribution/
 Availability
 Date _____
 DTIC _____
 A

DTIC
 ELECTE
 OCT 19 1981
 S D

PREFACE

This report is prepared under guidance contained in the Recommended Guidelines for Safety Inspection of Dams, for Phase I Investigations. Copies of these guidelines may be obtained from the Office of Chief of Engineers, Washington, D.C. 20314. The purpose of a Phase I Investigation is to identify expeditiously those dams which may pose hazards to human life or property. The assessment of the general condition of the dam is based upon available data and visual inspections. Detailed investigation and analyses involving topographic mapping, subsurface investigations, testing, and detailed computational evaluations are beyond the scope of a Phase I Investigation; however, the investigation is intended to identify any need for such studies.

In reviewing this report, it should be realized that the reported condition of the dam is based on observations of field conditions at the time of inspection along with data available to the inspection team. In cases where the reservoir was lowered or drained prior to inspection, such action, while improving the stability and safety of the dam, removes the normal load on the structure and may obscure certain conditions which might otherwise be detectable if inspected under the normal operating environment of the structure.

It is important to note that the condition of a dam depends on numerous and constantly changing internal and external conditions, and is evolutionary in nature. It would be incorrect to assume that the present condition of the dam will continue to represent the condition of the dam at some point in the future. Only through frequent inspections can unsafe conditions be detected and only through continued care and maintenance can these conditions be prevented or corrected.

Phase I inspections are not intended to provide detailed hydrologic and hydraulic analyses. In accordance with the established Guidelines, the Spillway Test flood is based on the estimated "Probable Maximum Flood" for the region (greatest reasonably possible storm runoff), or fractions thereof. Because of the magnitude and rarity of such a storm event, a finding that a spillway will not pass the test flood should not be interpreted as necessarily posing a highly inadequate condition. The test flood provides a measure of relative spillway capacity and serves as an aide in determining the need for more detailed hydrologic and hydraulic studies, considering the size of the dam, its general condition and the downstream damage potential.

PHASE I INSPECTION REPORT
NATIONAL DAM SAFETY PROGRAM
ARTHURS POND DAM
I.D. No. NY 490
DEC DAM No. 195B-3629 LOWER HUDSON RIVER BASIN
ORANGE COUNTY, NEW YORK

TABLE OF CONTENTS

	<u>PAGE NO.</u>
- ASSESSMENT	-
- OVERVIEW PHOTOGRAPH	-
1 PROJECT INFORMATION	1
1.1 GENERAL	1
1.2 DESCRIPTION OF PROJECT	1
1.3 PERTINENT DATA	4
2 ENGINEERING DATA	7
2.1 GEOLOGY	7
2.2 SUBSURFACE INVESTIGATION	7
2.3 DAM AND APPURTENANT STRUCTURES	8
2.4 CONSTRUCTION RECORDS	8
2.5 OPERATION RECORDS	8
2.6 EVALUATION OF DATA	9
3 VISUAL INSPECTION	11
3.1 FINDINGS	11
3.2 EVALUATION	13
4 OPERATION AND MAINTENANCE PROCEDURES	15
4.1 PROCEDURES	15
4.2 MAINTENANCE OF THE DAM	15
4.3 WARNING SYSTEM	15
4.4 EVALUATION	15
5 HYDRAULIC/HYDROLOGIC	17
5.1 DRAINAGE AREA CHARACTERISTICS	17
5.2 ANALYSIS CRITERIA	17
5.3 SPILLWAY CAPACITY	17
5.4 RESERVOIR CAPACITY	18
5.5 FLOODS OF RECORD	18
5.6 OVERTOPPING POTENTIAL	18
5.7 RESERVOIR EMPTYING POTENTIAL	18
5.8 EVALUATION	18

	<u>PAGE NO.</u>	
6	STRUCTURAL STABILITY	19
	6.1 EVALUATION OF STRUCTURAL STABILITY	19
	6.2 STABILITY ANALYSIS	20
7	ASSESSMENT/RECOMMENDATIONS	23
	7.1 ASSESSMENT	23
	7.2 RECOMMENDED MEASURES	24

APPENDIX

- A. PHOTOGRAPHS
- B. VISUAL INSPECTION CHECKLIST
- C. HYDROLOGIC/HYDRAULIC DATA AND COMPUTATIONS
- D. STABILITY COMPUTATIONS
- E. REFERENCES
- F. DRAWINGS
- G. BACKGROUND DOCUMENTS

PHASE I INSPECTION REPORT
NATIONAL DAM SAFETY PROGRAM

Name of Dam: Arthurs Pond Dam (I.D. No. NY 490)
State: New York
County: Orange
Stream: Unnamed Tributary to Moodna Creek
Date of Inspection: 8 January 1981

ASSESSMENT

Examination of available documents and a visual inspection of the dam and appurtenant structures did not reveal conditions which constitute an immediate hazard to human life or property.

Using the Corps of Engineers screening criteria, it has been determined that the dam would be overtopped for all storms exceeding approximately 44 percent of the Probable Maximum Flood (PMF). The spillway is, therefore, adjudged as "seriously inadequate", and the dam is assessed as unsafe, non-emergency.

The classification of "unsafe" applied to a dam because of a "seriously inadequate spillway" is not meant to connote the same degree of emergency as would be associated with an "unsafe" classification applied for a structural deficiency. It does mean, however, that, based on an initial screening and preliminary computations, there appears to be a serious deficiency in spillway capacity, so that if a severe storm were to occur, overtopping and failure of the dam are likely to take place, significantly increasing the hazard to loss of life downstream.

On the basis of stability analyses of the masonry/concrete gravity portion of the dam performed for this investigation, the factors of safety against overturning are generally low, and the locations of the resultants fall outside of the middle 1/3. The safety factor of the dam against sliding was determined to be less than the recommended guidelines for all loading conditions.

It is therefore recommended that, within 3 months of notification of the owner, detailed hydrologic and hydraulic investigations of the structure should be undertaken to more accurately determine the site-specific characteristics of the watershed and their effects upon the overtopping potential of the dam. At the same time, further analyses of the structural stability of the overflow and nonoverflow sections should be performed. The results of these investigations and analyses will determine the appropriate remedial measures required to achieve a spillway capacity adequate to discharge the outflow from at least the 1/2 PMF. In the interim, a detailed emergency action plan must be developed and implemented during periods of unusually heavy precipitation. Also, around-the-clock surveillance must be provided during these periods.

Current inspection and maintenance procedures by the owner are adequate, but need to be documented. Monitoring of the reservoir levels should be expanded to include readings during peak flow periods. The cracks and construction joints in the concrete cap should be monitored for further deterioration. The dam should be examined for seeps when the reservoir level is at normal pool.

The following remedial measures must be completed within one year:

1. Point the deteriorated joints in the spillway wing walls and in the top few courses of stones.
2. Replace the stones missing from the masonry portion of the dam.
3. Remove the stumps and their root systems from the downstream embankment. Backfill, compact, and seed the resultant holes.
4. Remove the fallen trees and other debris from the discharge area downstream of the spillway.

SUBMITTED: 

Granville Kester, Jr., P.E.
Vice President
MICHAEL BAKER, JR. of New York, INC.

APPROVED: 

Colonel W.M. Smith, Jr.
New York District Engineer

DATE: 30 JUN 1981



Overall View of Dam
Arthur Pond Dam
I.D. No. NY 490
11 March 1981

PHASE I INSPECTION REPORT
NATIONAL DAM SAFETY PROGRAM
ARTHURS POND DAM
I.D. No. NY 490
DEC DAM No. 195B-3629
HUDSON RIVER BASIN
ORANGE COUNTY, NEW YORK

SECTION 1: PROJECT INFORMATION

1.1 GENERAL

- a. Authority - The Phase I Inspection reported herein was authorized by the Department of the Army, New York District, Corps of Engineers, to fulfill the requirements of the National Dam Inspection Act, Public Law 92-367.
- b. Purpose of Inspection - This inspection was conducted to evaluate the existing conditions of the dam, to identify deficiencies and hazardous conditions, to determine if these deficiencies constitute hazards to life and property, and to recommend remedial measures where required.

1.2 DESCRIPTION OF PROJECT

- a. Description of Dam and Appurtenances - Arthurs Pond Dam is a combination earth embankment and masonry-concrete gravity dam 248 feet long and 26.6 feet high¹. The left² part of the dam is an earth embankment 119 feet long with a concrete core, the top of which forms part of the crest. The total crest width averages 4.6 feet, of which 2.0 feet is concrete and the remainder is earth. The upstream embankment has a slope of 1V:2.5H (Vertical to Horizontal) and is riprapped. The downstream embankment has a slope of 1V:1.9H and is protected by vegetation. From the right end of the earth embankment, a rectangular opening in the left end of the masonry part of the dam forms the service (principal) spillway control section and is separated from the remainder of the dam by masonry wing walls. To the right of the service spillway, a masonry (stone and cement) gravity dam

¹Measured from the streambed at the downstream toe to the minimum crest of the dam.

²Facing downstream.

with a concrete cap extends to the right abutment. The length of this masonry section, including the service spillway, is 129 feet. The masonry base has a vertical upstream face and a stepped downstream face (Photo 5), a top width of 7.5 feet and a maximum bottom width of 16.0 feet. A concrete cap, 4.4 feet high with a top width of 3.0 feet and a bottom width of 5.0 feet, is built on top of the masonry base. The minimum top of dam elevation is 999.9 feet T.B.M.³ and occurs along the crest of the earth embankment about 40 feet left of the service spillway.

The service spillway is a 14.0 foot wide and 4.8 foot deep opening in which a concrete weir has been installed. This weir is 2.0 feet high with a 1V:1H downstream face, a vertical upstream face and a top width of 2.5 feet. The crest elevation of the weir is 997.1 feet T.B.M. The masonry and concrete wing walls extend 24 feet downstream of the weir on both sides of the spillway and along the end of the earth embankment upstream of the weir (Photos 1 and 2). A concrete slab placed on top of the wing walls serves as a walkway over the spillway opening. A natural channel approximately 100 feet left of the left abutment of the dam serves as an auxiliary spillway. This channel is roughly trapezoidal-shaped with a bottom width of about 20 feet and side slopes of about 1V:10H. The crest elevation of this spillway is 999.1 feet T.B.M., 2.0 feet above the service spillway crest and 0.8 feet below the minimum top of dam.

A 12-inch diameter cast iron pipe with a gate control serves as a reservoir drain (Photo 3). The outlet for this pipe is located near the center of the masonry part of the dam. The invert elevation of the inlet of this pipe is 976.2 feet T.B.M.

- b. Location - Arthurs Pond Dam is located on an unnamed tributary to Moodna Creek, approximately 3500 feet upstream of Aleck Meadow Reservoir Dam, in Orange County, New York. This is approximately 3.0 miles south of Cornwall-on-the-Hudson, New York.

³All elevations are referenced to a Temporary Bench Mark (T.B.M.) on the top left upstream corner of the concrete slab over the spillway with an assumed elevation of 1000.0 feet.

- c. Size Classification - Arthurs Pond Dam is 26.6 feet high and the reservoir storage capacity at the crest of the dam (elevation 999.9 feet T.B.M.) is 259 acre-feet. Therefore, the dam is in the "small" size category as defined by the Recommended Guidelines for Safety Inspection of Dams (Reference 15, Appendix E).
- d. Hazard Classification - A four-lane highway (U.S. Route 9W) crosses the stream 11,000 feet downstream of the dam. Several homes are located along the stream approximately 400 feet downstream of the bridge. The Town of Cornwall is located approximately 3 miles downstream of the dam. In the event of a dam failure, loss of life is possible, as well as economic loss in the form of damage to the homes and the U.S. Route 9W bridge. Arthurs Pond Dam is therefore considered in the "high" hazard category as defined by the Recommended Guidelines for Safety Inspection of Dams. The hazard classification used to categorize dams is a function of location only and is not related to its stability or probability of failure.
- e. Ownership - Arthurs Pond Dam is owned by Harvard University, Cambridge, Massachusetts. The Village of Cornwall-on-the-Hudson, Village Hall, New York has water rights to the dam and maintenance responsibilities for the dam. The contact person is Mr. Ralph Smith, Village Engineer (telephone number (914) 534-5050).
- f. Purpose of the Dam - Arthurs Pond Dam is used to impound water for the Village of Cornwall-on-the-Hudson's water supply. Water from the dam runs downstream in a natural channel to the Aleck Meadow Reservoir. Water discharged from the Aleck Meadow Reservoir flows down a natural channel to the village's filtration plant.
- g. Design and Construction History - The original dam was built in the 1920's, but the builder or designer is not known. The crests of the dam and spillway were raised to their present heights in 1958. These alterations were designed by Morrell Vrooman Engineers, 21 North Main Street, Gloversville, New York in July 1958. Approval was granted by the New York State Department of Public Works in August 1958 and, according to the Construction Application, construction was completed in December 1958. The contractor is not known.

- h. Normal Operating Procedures - The reservoir is usually maintained at the crest of the weir in the service spillway at elevation 997.1 feet T.B.M. According to the owner's representative, the slide gate that controls flow through the 12-inch cast iron reservoir drain is operated at least once a year as part of a regular maintenance program.

1.3 PERTINENT DATA

a.	<u>Drainage Area (acres)</u> -	141
b.	<u>Discharge at Dam (c.f.s.)</u> -	
	Service Spillway at Top of Dam	149
	Auxiliary Spillway at Top of Dam	37
	Reservoir Drain at Service Spillway Crest	17
c.	<u>Elevations (Feet T.B.M.)</u> -	
	Minimum Top of Dam	999.9
	Auxiliary Spillway Crest	999.1
	Service Spillway Crest	997.1
	Reservoir Drain Inlet Invert	976.2
	Reservoir Drain Outlet Invert	974.8
d.	<u>Reservoir Surface Area (Acres)</u> -	
	Service Spillway Crest	12.9
	Auxiliary Spillway Crest	17.2
	Minimum Top of Dam	18.0
e.	<u>Storage Capacity (Acre-Feet)</u> -	
	Service Spillway Crest	216
	Auxiliary Spillway Crest	246
	Minimum Top of Dam	259
f.	<u>Dam</u> -	
	Type: Half earth embankment with concrete core, half masonry gravity dam with concrete cap.	
	Length (Feet)	
	Earth Embankment	119
	Masonry Gravity Dam (including spillway)	129
	Slopes (Vertical:Horizontal)	
	Earth Embankment	

Upstream	1:2.5
Downstream	1:1.9
Masonry Gravity Dam	
Upstream	Vertical
Downstream (stepped)	1:0.5 (Approx.)

Crest Width (Feet)	
Earth Embankment	4.6
Masonry Gravity Dam	3.0

g. Spillway -

Service

Type: Concrete weir in rectangular control section.

Weir Length (Feet) 14.0

Weir Height (Feet) 2.0

Weir Width (Feet) 2.5

Auxiliary

Type: Open, uncontrolled, trapezoidal channel

Bottom Width (Feet) 20.0

Side Slopes (Vertical:Horizontal) 1:10

h. Reservoir Drain -

Type: 12-inch diameter, cast iron pipe

Control: Manual control gate at outlet

SECTION 2: ENGINEERING DATA

2.1 GEOLOGY

Arthurs Pond Dam is located in the southern end of the "New England Uplands" physiographic province of New York State. The province is diverse and geologically complex. Rocks in the uplands are either metamorphic or igneous. The large relief typical of this province is directly related to the very durable nature of the rocks contained therein. Bedrock occurring in the immediate vicinity of the dam reportedly consists of Middle Proterozoic Era (greater than 600 million years old) granite and granitic gneiss. Gneiss was noted as outcropping on both abutments of the dam during the visual inspection. The region has been repeatedly glaciated by the major ice sheet advances which occurred during the Pleistocene Epoch. The most recent ice advance ended approximately 11,000 years ago.

A northeast-southwest trending normal or strike slip fault plane is indicated on available geologic maps for New York State by J. G. Broughton and others (1970) as being located less than 1000 feet downstream of the dam. Sutherland and Sphagnum Ponds, located just southwest of Arthurs Pond Dam, appear to be situated on the immediate south (or east) side of the fault plane (References 1, 2, and 3, Appendix E).

2.2 SUBSURFACE INVESTIGATION

Detailed subsurface information was not available for consideration as part of this investigation. During the visual inspection, bedrock (gneiss) was observed to outcrop extensively in the area of the dam. Considering the high topographic location of the dam and extensive outcropping, any local soils are expected to be very thin and comprised of a combination of poorly sorted glacial till and less abundant residual stony material produced as a result of weathering of the underlying gneiss.

According to the available (preliminary) soils report for Orange County prepared by the Soil Conservation Service (Reference 4, Appendix E), and taking into account conditions perceived in the field, Hollis Rocky Association Soils are the primary materials in the immediate vicinity of the dam. These soils are described as shallow (1-2 feet thick), excessively to well

drained, moderately coarse to medium textured soils formed in low lying glacial till dominated by granite materials. Bedrock outcrops are estimated to occupy 2 to 10 percent of the surface and there are small areas in which bedrock may be considerably deep. Depth to the seasonal high water table is estimated to be 2 feet.

2.3 DAM AND APPURTENANT STRUCTURES

A single drawing for the dam prepared by Morrell Vrooman Engineers for the Village of Cornwall-on-the-Hudson, was available for review during these investigations. The drawing illustrates the original general dam design features as well as improvements to increase its height, which were completed in 1958. This drawing is included in Appendix F. The dam was originally built during the 1920's.

The left half of the structure is comprised of an earth embankment with a concrete core wall. The right half of the structure is a masonry gravity dam (constructed primarily of large cemented stones). A masonry spillway is located in the approximate center of the structure between the embankment and gravity portions. The original embankment has been raised and the concrete core wall extended. The masonry gravity portion and spillway have been capped with concrete. The available drawing indicates that the masonry portions of the dam are founded on bedrock at a very shallow depth. A 12-inch inside diameter, cast iron pipe serves as the outlet for the dam. A slide gate controlled by hand crank is present at the outlet. The existing dam is illustrated by a Field Sketch included in Appendix F.

2.4 CONSTRUCTION RECORDS

No information concerning construction of the structure is available other than the previously discussed 1958 drawing for improvements and an accompanying permit application to the New York Department of Public Works (the application is included in Appendix G).

2.5 OPERATION RECORDS

Water levels in the reservoir are measured periodically (at least weekly) from the crest of the service spillway and are recorded by Village of Cornwall-on-the-Hudson

personnel to monitor water availability. At the same time, visual inspections of the dam are made. The slide gate controlling discharges through the 12-inch cast iron outlet for the reservoir is checked periodically and operated at least once each year. Maintenance is performed as needed.

2.6 EVALUATION OF DATA

The background information collected during the investigation was obtained from Mr. Ralph Smith of the Village of Cornwall-on-the-Hudson. Available engineering data are considered adequate and reliable for Phase I Inspection purposes, with the exception that foundation characteristics are not well known.

SECTION 3: VISUAL INSPECTION

3.1 FINDINGS

- a. General - The visual inspection of Arthurs Pond Dam was conducted on 8 January 1981. The weather was clear and sunny with temperatures averaging 15° F. The ground was covered by 3 inches of snow, and the surface of the reservoir was frozen. At the time of the inspection, the elevation of the reservoir was 985.6 feet T.B.M., or 11.5 feet below the normal pool. This low reservoir level was attributed to an unusually low amount of precipitation occurring in the watershed prior to the inspection. Deficiencies found during the inspection will require remedial treatment. A Field Sketch of conditions found during the inspection is included in Appendix F. The complete Visual Inspection Checklist is presented as Appendix B. Because there was a snow cover on the dam during the initial inspection, a follow-up inspection was carried out on 11 March 1981.
- b. Spillway - The service spillway, including the concrete weir, is in fair condition. The cement joints of the adjacent masonry wing walls are badly deteriorated. A stone is missing from the right downstream side of the spillway near the top of the right wing wall. The immediate discharge channel appears to be well riprapped. There are many fallen trees and other debris present in the discharge area, approximately 30 feet downstream of the spillway crest just beyond the wing walls (Photo 2). The auxiliary spillway, as described in Section 1.2a, is in generally good condition. A dirt and gravel service road to the dam runs along the bottom of the auxiliary spillway and the side slopes are vegetated with grass, sparse brush, and trees. No evidence of erosion or sloughing was observed either at the service spillway or in the auxiliary spillway.
- c. Embankment - The vertical and horizontal alignments of the crest appeared satisfactory. Crest elevations vary by a maximum of only 0.3 foot. The entire upstream slope of the earth embankment is well riprapped. The downstream side of the earth embankment is vegetated with low grass. Several large trees were recently cut down on the downstream embankment, but the stumps remain (Photo 8). One

of these stumps is partly uprooted, leaving a hole in the slope. The exposed portion of the concrete core on the crest is in good condition with no deterioration of expansion joint material.

- d. Gravity Section - On the masonry portion of the dam, the cemented joints of the top few courses of stones are deteriorated (Photo 7). One of the stones is missing from the top of the downstream face. The surfaces of the concrete cap are in fair to good condition; however, cracks extending completely through the concrete cap were observed at three points (Photo 6). These cracks have not opened significantly. Expansion material in the two construction joints in the concrete cap is slightly deteriorated (Photo 5). The contact areas of the dam with the natural ground appeared to be satisfactory. No signs of erosion; sloughing; or seepage were observed on the dam or the abutments, and no unusual movement or seepage was observed at or beyond the toe. However, the ground surface was frozen and covered by 3 inches of snow.
- e. Outlet Works - The 12-inch diameter, cast iron reservoir drain and gate control generally appear to be in fair condition. The gate appears to have been operated recently. A small plunge pool protected by riprap is located at the outlet (Photo 3).
- f. Downstream Channels - The downstream channel is a natural stream channel with a steep (7 percent) slope flowing through a narrow, wooded valley to Aleck Meadow Reservoir, approximately 3000 feet downstream.
- g. Reservoir - The slopes around the reservoir are moderately steep with numerous rock outcroppings and are primarily wooded. No signs of erosion or sloughing were observed. Since the reservoir was frozen over, sedimentation could not be observed, but it is not expected to be significant due to the heavy vegetation and lack of development in the watershed.
- h. Follow-up Inspection - Because there was a snow cover on the dam during the initial inspection, a follow-up inspection was conducted on 11 March 1981. The reservoir level was approximately 1.5 feet below the spillway crest at the time of the

second inspection. Two small seeps were observed in the masonry wall below the crest of the weir. Each of these seeps was flowing at a rate of less than 0.5 g.p.m. Three additional seeps, each with a flow rate of less than 0.5 g.p.m., were observed on the downstream face of the dam approximately 6-8 feet below the crest of the dam. A small wet area was also observed at the toe of the left section of the embankment. The masonry wall above the outlet works, approximately half-way down from the crest of the dam, has deteriorated. Some of the stones in this area are loose; others are missing entirely.

3.2 EVAULATION

Visual inspection revealed several deficiencies in this structure. The following items were noted:

1. The cement joints of the spillway wing walls are badly deteriorated,
2. A stone is missing from the right downstream side of the spillway near the top of the right wing wall.
3. On the masonry portion of the dam, the cemented joints of the top few courses of stones are deteriorated.
4. One of the stones is missing from the top of the downstream face.
5. The masonry wall above the outlet works has deteriorated.
6. Two small seeps were found in the masonry wall below the crest of the weir; three other small seeps were found on the downstream face of the dam. A small wet area was observed at the toe of the left section of the embankment.
7. The stumps and root systems of several large trees are present in the downstream embankment. One of the stumps is partly uprooted.
8. There are fallen trees and other debris in the spillway discharge area.

SECTION 4: OPERATION AND MAINTENANCE PROCEDURES

4.1 PROCEDURES

There are no formal operating procedures. The operation of the dam is normally an automatic function controlled by the crest of the weir in the service spillway at elevation 997.1 feet T.B.M. The reservoir level can be lowered to elevation 976.2 feet T.B.M. by means of a reservoir drain with a manually operated gate control.

4.2 MAINTENANCE OF THE DAM

Maintenance of the dam is the responsibility of The Village of Cornwall-on-the-Hudson. Water levels in the reservoir are measured periodically, at least weekly, from the crest of the service spillway and are recorded by the Village of Cornwall-on-the-Hudson personnel to monitor water availability. At the same time, visual inspections of the dam are made. Overgrowth on the embankments will reportedly be cut annually. The only operating facility at Arthurs Pond Dam is the gate-controlled reservoir drain. According to the owner's representative, the gate is checked on a periodic basis and operated at least once a year.

4.3 WARNING SYSTEM

At the time of the inspection, there was no warning system or emergency action plan in operation.

4.4 EVALUATION

Past maintenance of the dam and operating facilities appears to have been adequate, but, except for the water level measurements, the past activities have not been documented. A checklist should be compiled by the owner's representative to document the findings made during the periodic inspections and the maintenance items completed. A warning system and emergency action plan should be developed and put into operation.

SECTION 5: HYDRAULIC/HYDROLOGIC

5.1 DRAINAGE AREA CHARACTERISTICS

The drainage area upstream of Arthurs Pond Dam was delineated using the Cornwall, New York USGS 7.5 minute quadrangle. The entire watershed is heavily wooded and steeply sloped with no development. The total drainage area is 141 acres (0.22 square miles).

5.2 ANALYSIS CRITERIA

An hydrologic analysis of the watershed and hydraulic analysis of the dam was conducted using the U.S. Army Corps of Engineers' Flood Hydrograph Package HEC-1 DB computer program (Reference 12, Appendix E). The unit hydrograph was defined using the Snyder's Unit Hydrograph Method. Estimates of Snyder's hydrograph coefficients were developed from average coefficients from the Hydrologic Flood Routing Model for Lower Hudson River Basin (Reference 16, Appendix E). Precipitation data was taken from Hydrometeorological Report No. 33 (Reference 8, Appendix E). Rainfall losses were estimated at an initial loss of 1.0 inch and a constant loss rate of 0.1 inch per hour thereafter. The hydraulic capacity of the dam, reservoir, and spillway was determined by incorporating the Modified Puls Routing Method. All flood routings were begun with the reservoir at normal pool level. Outlet discharge capacity was computed by hand. The Probable Maximum Flood (PMF) and 1/2 Probable Maximum Flood (1/2 PMF) were developed and routed through the reservoir.

5.3 SPILLWAY CAPACITY

With the reservoir level at the minimum top of dam, the capacities of the service and auxiliary spillways were determined to be 149 c.f.s. and 37 c.f.s., respectively.

5.4 RESERVOIR CAPACITY

The storage capacity of Arthurs Pond Dam at normal pool is 216 acre-feet. The storage capacity of the reservoir at the minimum top of dam is 259 acre-feet. Therefore, flood control storage of the reservoir between the spillway crest and top of dam is 43 acre-feet. This volume represents a total of 3.66 inches of runoff from the watershed.

5.5 FLOODS OF RECORD

Maximum discharges and maximum depth of flow in the reservoir have not been recorded. According to the owner's representative, the heaviest rainfall during the past several years occurred in March 1980 when 2.5 inches of rain fell in a period of 6 hours with no damage to the structure.

5.6 OVERTOPPING POTENTIAL

The maximum combined capacity of the spillways is 186 c.f.s. before overtopping would occur. The peak outflows of the PMF and 1/2 PMF are 629 c.f.s. and 219 c.f.s., respectively. Therefore, the spillways are capable of passing 44 percent of the PMF before overtopping would occur.

5.7 RESERVOIR EMPTYING POTENTIAL

The reservoir can be drawn down by means of a 12-inch cast iron pipe as described in Section 1.2a. Neglecting inflow, the reservoir can be drawn down from normal pool in approximately 16.0 days. This is equivalent to an approximate drawdown rate of 1.3 foot per day, based on the hydraulic height measured from normal pool divided by the time to dewater the reservoir.

5.8 EVALUATION

Arthurs Pond Dam is a "small" size - "high" hazard dam requiring the spillway to pass a flood in the range of the 1/2 PMF to PMF. The PMF and 1/2 PMF were routed through the watershed and dam. It was determined that the spillway is capable of passing 44 percent of the PMF before overtopping the dam. The spillway is, therefore, judged to be "seriously inadequate".

Conclusions pertain to present conditions, and the effect of future development on the hydrology has not been considered.

SECTION 6: STRUCTURAL STABILITY

6.1 EVALUATION OF STRUCTURAL STABILITY

- a. Visual Observations - No signs of instability were noted during the field inspection. Minor problems observed which could affect the stability of the structure include:
 1. The cement is deteriorated between individual stones of the top few courses of the masonry part of the dam to the right of the spillway.
 2. The cement is deteriorated between stones of the spillway wing walls (upstream and downstream). Large flows through the spillway could potentially erode the embankment behind the left wing walls.
 3. Three cracks extend completely through the concrete cap on the masonry part of the dam to the right of the spillway.
 4. Trees were recently cut from the downstream embankment, but the stumps were not removed. The stumps will deteriorate with time if not removed.
- b. Design and Construction Data - No design information regarding the stability of the structure was available.
- c. Operating Records - The slide gate for the 12-inch outlet which can be used to drain the impoundment, if necessary, is checked periodically and operated at least once a year. The structure is visually inspected at least once a week when reservoir water level measurements are made. A rainfall of 2.5 inches in a period of 6 hours reportedly occurred during March 1980 with no damage to the structure.
- d. Post Construction Changes - The structure was built during the 1920's. In 1958, the operating height of the dam was increased by installing a 2-foot high concrete cap on the existing masonry spillway. The masonry portion of the dam to the right of the spillway was also raised 2 feet by removing the existing top 2 feet 5 inches and

replacing it with a 4-foot 5-inch concrete cap. The left half of the dam was raised 2 feet by adding to the concrete core and the upstream and downstream embankments. The left half of the dam should be just slightly higher than the right masonry half, according to the available plans. This is a logical arrangement to hopefully route any overtopping flows over the masonry segments of the dam rather than over the embankments. However, a profile across the dam surveyed during the field inspection revealed that the left half of the dam is slightly lower than the right.

6.2 STABILITY ANALYSIS

The results of any previous stability analyses were not available for reference during this evaluation.

- a. Gravity Segment of Dam - A structural stability analysis has been conducted for the maximum masonry/concrete gravity section of the dam situated in the vicinity of the outlet. The cases analyzed and respective results are as follows:

<u>Case</u>	<u>Description of Loading Conditions</u>
1	Normal operating conditions with reservoir level at the spillway crest, full uplift, and no tailwater.
2	Same as Case 1 with the addition of ice loading of 5000 pounds per lineal foot.
3	Reservoir level during 1/2 PMF (SDF) (elev. 1000.07 T.B.M.), full uplift as in Case 1, with a tailwater of 4.0 feet.
4	Reservoir level during the PMF (elev. 1000.6 T.B.M.), full uplift as in Case 1, with a tailwater of 6.0 feet.

Case	Factor of Safety		Location of Resultant from Toe (ft.)
	Overturning	Sliding	
1	1.46	3.11	5.0
2	1.03	2.40	0.45
3	1.07	2.17	1.08
4	0.92	1.88	-1.77

Notes: Location of middle 1/3 is 5.58 to 11.16 feet from the downstream toe.

A negative value indicates that the location of the resultant is downstream from the toe.

A value of 2KSF was used as a conservative approximation of the shear strength of weathered rock.

Arthurs Pond Dam is situated in Seismic Zone 1. Seismic loading evaluations are not necessary for dams in this seismic zone.

In all cases, the factors of safety against overturning are generally low, and the locations of the resultants fall outside of the middle 1/3. Therefore, the masonry-gravity portion of the dam is not considered safe against overturning. The factor of safety against sliding was less than 3 for all but one of loading conditions. However, the structure has withstood normal loading conditions in the past without apparent damage, and the analyses may not indicate the true field conditions or proper loading conditions. Because overturning during the SDF would result in a probable loss of life downstream of the dam, a detailed stability analysis of the masonry-gravity portion of the dam should be performed by a qualified engineering firm within three months of notification of the owner.

- b. Embankment - The structure to the left of the spillway consists of an earth embankment with a 4-foot thick concrete core wall. The core wall is assumed to be founded on bedrock. The embankment materials are believed to be a sand silt mixture.

No major signs of distress were observed in connection with the earth embankment. However, a small wet area was observed at the toe of the left section of the embankment. Also, any discharge through the auxiliary spillway will run along the toe of the embankment.

Detailed stability analyses should be carried out for both the embankment and gravity portions of the dam within three months of notification of the owner.

SECTION 7: ASSESSMENT/RECOMMENDATIONS

7.1 ASSESSMENT

- a. Safety - Examination of available documents and visual inspections of Arthur's Pond Dam did not reveal any conditions which are considered to be hazardous.

Using the Corps of Engineers screening criteria for review of spillway adequacy, it has been determined that the dam would be overtopped for all storms exceeding approximately 44 percent of the PMF. The overtopping of the dam could result in dam failure, increasing the hazard to loss of life downstream. The spillway is, therefore, adjudged as "seriously inadequate" and the dam is assessed as unsafe, non-emergency.

The "unsafe" classification applied to a dam because of a "seriously inadequate spillway" is not meant to connote the same degree of emergency as would be associated with an "unsafe" classification applied for a structural deficiency. It does mean, however, that based on an initial screening and preliminary computations, there appears to be a serious deficiency in spillway capacity so that if a severe storm were to occur, overtopping and failure of the dam would take place, significantly increasing the hazard to loss of life downstream of the dam.

The stability analyses of the gravity section of the dam performed for this investigation indicate that the factors of safety against overturning and sliding may be inadequate.

- b. Adequacy of Information - Information available for use in preparing this report included a construction drawing of "Water Works Improvements, Arthurs Pond Dam Alterations" by Morrell Vrooman Engineers (included in Appendix F), a copy of the "Application for the Construction or Reconstruction of a Dam" submitted to and approved by the New York State Department of Public Works, and a copy of "Dam Inspection Report (by Visual Inspection)" by the New York State Department of Environmental Conservation (included in Appendix G). All evaluations and assessments in this report were based on field

observations, conversations with the owner's representative, available engineering data, and office analyses. The information collected is considered adequate for a Phase I Inspection.

- c. Need for Additional Information - Detailed hydrologic and hydraulic investigations of the structure are considered necessary to more accurately determine the overtopping potential of the dam. A detailed stability analysis of the dam is considered necessary to determine actual stability conditions.
- d. Urgency - The detailed hydrologic and hydraulic investigations and stability analyses must be initiated within three months of notification to the owner. Within one year, remedial measures resulting from these investigations must be initiated, with completion of these measures during the following year. In the interim, a detailed emergency action plan must be developed and implemented during periods of unusually heavy precipitation. Also, around-the-clock surveillance must be provided during these periods. The problem areas listed below must be corrected within one year of notification.

7.2 RECOMMENDED MEASURES

The regular inspections and maintenance procedures presently being conducted by the owner's representative appear to be adequate, although some form of documentation is needed. A thorough checklist should be compiled by the owner's representative and completed during each inspection. Maintenance items should be completed annually. Monitoring of the reservoir level should be expanded to include reservoir levels above normal pool. The cracks and construction joints in the concrete cap on the masonry part of the dam should be monitored very closely for leakage or further cracking and deterioration, which could necessitate remedial measures. The dam should also be examined during future inspections for any signs of seepage when the reservoir level is at normal pool.

The following remedial measures must be completed within one year:

1. Point the deteriorated joints in the spillway wing walls and in the top few courses of stones.

2. Replace the stones missing from the masonry portion of the dam.
3. Remove the stumps and their root systems from the downstream embankment. Backfill, compact, and seed the resultant holes.
4. Remove the fallen trees and other debris from the discharge area downstream of the spillway.

APPENDIX A
PHOTOGRAPHS

CONTENTS

- Photo 1: Spillway Approach - 11 March 1981
- Photo 2: Spillway Discharge Channel and Masonry Wing Walls - 11 March 1981
- Photo 3: 12-inch Outlet and Slide Gate - 11 March 1981
- Photo 4: Downstream Side of Masonry Section of Dam on Right of Spillway - 11 March 1981
- Photo 5: Construction Joint in Concrete Cap on Masonry Section of Dam - 8 January 1981
- Photo 6: Crack in Concrete Cap on Masonry Section of Dam - 8 January 1981
- Photo 7: Deteriorated Joints in Top Courses of Masonry Section of Dam - 8 January 1981
- Photo 8: Uprooted Tree Stump on Downstream Embankment, Concrete Core of Embankment - 11 March 1981

ARTHURS POND DAM



Photo 1. Spillway Approach
11 March 1981

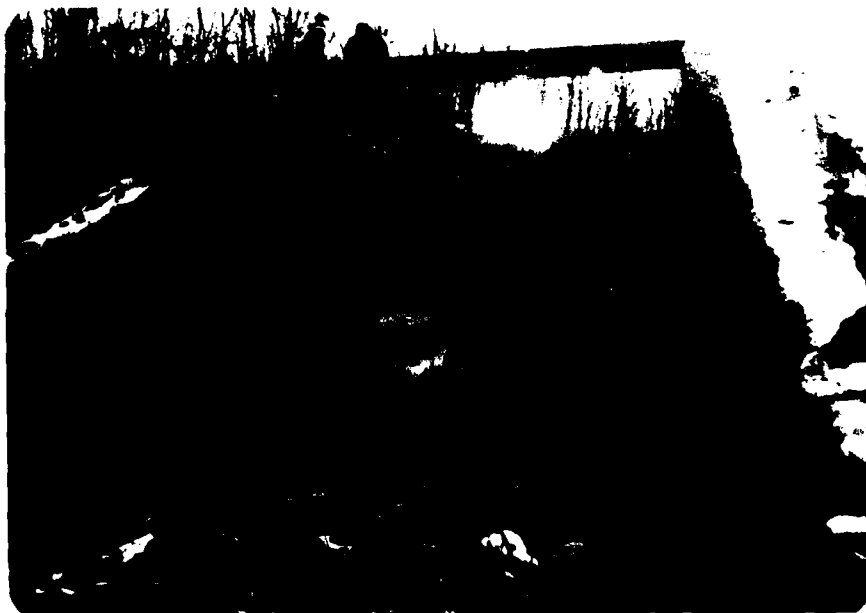

Photo 2. Spillway Discharge Channel and Masonry Wing Walls
11 March 1981

ARTHURS POND DAM



Photo 3. 12-Inch Outlet and Slide Gate
11 March 1981



Photo 4. Downstream Side of Masonry Section of
Dam on Right of Spillway
11 March 1981

ARTHURS POND DAM



Photo 5. Construction Joint in Concrete Cap
on Masonry Section of Dam
8 January 1981



Photo 6. Crack in Concrete Cap on Masonry Section of Dam
8 January 1981

ARTHURS POND DAM



Photo 7. Deteriorated Joints in Top Courses
of Masonry Section of Dam
8 January 1981



Photo 8. Uprooted Tree Stump on Downstream Embankment,
Concrete Core of Embankment
11 March 1981

APPENDIX B
VISUAL INSPECTION CHECKLIST

VISUAL INSPECTION CHECKLIST

1) Basic Data

a. General

Name of Dam Arthurs Pond Dam

Fed. I.D. # NY 490 DEC Dam No. 490

River Basin Hudson

Location: Town South of Cornwall County Orange

Stream Name Unnamed

Tributary of Moodna Creek

Latitude (N) 41°24' Longitude (W) 74°01.3'

Type of Dam Combined masonry gravity/earth dam.

Hazard Category High

Date(s) of Inspection 8 January 1981

Weather Conditions Clear, 15°F., 3-4 in. snow cover on most of dam.

Reservoir Level at Time of Inspection Elevation 985.6 ft. T.B.M.*

b. Inspection Personnel Jeffrey A. Quay, Larry A. Diday, David W. Hupe

c. Persons Contacted (Including Address & Phone No.) _____

Mr. Ralph Smith

Village Hall - 3 River Avenue

Cornwall on the Hudson, NY 12520

914/534-5050

d. History:

Date Constructed 1920 Date(s) Raised 1958

Designer Unknown

Constructed By Unknown

Owner Harvard University

*Temporary Bench Mark (T.B.M.) is top left upstream corner of concrete slab (top of dam) over spillway. Assumed elevation is 1000.0 ft.

2) Embankment

a. Characteristics

- (1) Embankment Material Probably silty sand.

- (2) Cutoff Type Unknown

- (3) Impervious Core Concrete

- (4) Internal Drainage System None

- (5) Miscellaneous _____

b. Crest

- (1) Vertical Alignment Satisfactory, uniform.

- (2) Horizontal Alignment Satisfactory, uniform.

- (3) Surface Cracks None observed. However, a deep snow cover was present.

- (4) Miscellaneous _____

c. Upstream Slope

- (1) Slope (Estimate) (V:H) 1:2.5

- (2) Undesirable Growth or Debris, Animal Burrows None observed

(3) Sloughing, Subsidence, or Depressions None observed

(4) Slope Protection The entire slope is well riprapped.

(5) Surface Cracks or Movement at Toe The toe was inundated.

d. Downstream Slope

(1) Slope (Estimate - V:H) 1:1.9

(2) Undesirable Growth or Debris, Animal Burrows Large trees were recently cut down, but the stumps remain. Overgrowth will reportedly be cut annually.

(3) Sloughing, Subsidence or Depressions One large tree stump was up-rooted, leaving a hole on the downstream slope. The area of the hole is subject to erosion. The slope generally appears stable.

(4) Surface Cracks or Movement at Toe None observed. However, a deep snow cover was present.

(5) Seepage None observed. However, a deep snow cover was present.

(6) External Drainage System (Ditches, Trenches, Blanket) None

(7) Condition Around Outlet Structure Not Applicable

(8) Seepage Beyond Toe None observed. However, a deep snow cover was present.

e. Abutments - Embankment Contact The contacts appeared to be satisfactory, but were completely snow covered.

(1) Erosion at Contact None observed

(2) Seepage Along Contact None observed

3) Drainage System

a. Description of System None

b. Condition of System _____

c. Discharge from Drainage System _____

4) Instrumentation (Monumentation/Surveys, Observation Wells, Weirs, Piezometers, Etc.) None

5) Reservoir

a. Slopes Moderately steep with numerous rock outcrops. Primarily wooded.

b. Sedimentation Unknown. The reservoir was frozen over.

c. Unusual Conditions Which Affect Dam None

6) Area Downstream of Dam

a. Downstream Hazard (No. of Homes, Highways, etc.) The town of Cornwall is located approximately 3 mi. downstream; U.S. Route 9W is located 11,000 ft. downstream; several homes are located approximately 11,400 ft. downstream of the dam.

b. Seepage, Unusual Growth None observed

c. Evidence of Movement Beyond Toe of Dam None observed

d. Condition of Downstream Channel The channel is a natural stream channel with a steep slope. The stream valley is narrow and wooded.

7) Spillway(s) (Including Discharge Conveyance Channel)

- a. General The service spillway is mostly masonry construction. Masonry wing walls are present on the left upstream and downstream sides to protect the embankments. A masonry wing wall is present on the right downstream side to divert flows from the toe. A 2 ft. high concrete weir was added to the original spillway crest in 1958.
- b. Condition of Service Spillway The spillway, including the concrete weir, is in fair condition. Cement joints of the masonry wing walls are badly deteriorated. A stone is missing from the right downstream side of the spillway near the top of the right wing wall.
- c. Condition of Auxiliary Spillway A roughly trapezoidal-shaped natural channel approximately 100 ft. left of the left abutment forms an auxiliary spillway. This channel is generally unobstructed.
- d. Condition of Discharge Conveyance Channel The immediate service spillway discharge channel appears to be well riprapped. Many fallen trees are present in the discharge area approximately 30 ft. downstream of the service spillway crest just beyond the wing walls.

8) Reservoir Drain/Outlet

Type: Pipe X Conduit _____ Other _____

Material: Concrete _____ Metal X Other _____

Size: 12 in. Length Approximately 20 ft.

Invert Elevations: Entrance 976.2 T.B.M.

Exit 974.8 T.B.M.

Physical Condition (Describe): Unobservable

Material: The outlet was constructed with cast iron pipe.

Joints: Unknown Alignment Unknown

Structural Integrity: The outlet works generally appear to be in fair condition.

Hydraulic Capability: _____

Means of Control: Gate X Valve _____ Uncontrolled _____

Operation: Operable X Inoperable _____ Other _____

Present Condition (Describe): The gate appears to have been operated recently. It is reportedly checked on a periodic basis and operated at least once each year.

9) Structural

a. Concrete Surfaces The cemented joints of the top few courses of the masonry part of the dam are deteriorated. The newer concrete surfaces are generally in fair to good condition. A stone is missing from the top downstream side of the masonry portion of the dam.

b. Structural Cracking Three cracks extend completely through the concrete cap to the masonry dam right of the spillway. The cracks have not opened significantly.

c. Movement - Horizontal & Vertical Alignment (Settlement) None observed

d. Junctions with Abutments or Embankments Satisfactory

e. Drains - Foundation, Joint, Face None

f. Water Passages, Conduits, Sluices None

g. Seepage or Leakage None observed

h. Joints - Construction, etc. There are two construction joints in the concrete cap to the masonry dam right of the spillway. The expansion material in the joints is deteriorated slightly. There are two construction joints in the concrete addition to the core wall of the embankment left of the spillway. The joints appear to be in good condition.

i. Foundation The foundation consists of bedrock (gneiss).

j. Abutments The abutments are largely bedrock (gneiss).

k. Control Gates Refer to 8) Reservoir Drain/Outlet.

l. Approach & Outlet Channels Unobstructed

m. Energy Dissipators (Plunge Pool, etc.) A small plunge pool exists at the outlet.

n. Intake Structures Submerged

o. Stability The masonry portions of the dam appear to be stable.

p. Miscellaneous _____

10) Appurtenant Structures (Power House, Lock, Gatehouse, Other)

a. Description and Condition None

APPENDIX C
HYDROLOGIC/HYDRAULIC DATA AND COMPUTATIONS

MICHAEL BAKER, JR., INC.

THE BAKER ENGINEERS

Box 280
Beaver, Pa. 15009

Subject ARTHUR'S POND DAM S.O. No. _____

APPENDIX C - HYDROLOGIC AND Sheet No. _____ of _____

HYDRAULIC COMPUTATIONS Drawing No. _____

Computed by _____ Checked by _____ Date _____

<u>SUBJECT</u>	<u>PAGE</u>
CHECK LIST FOR DAMS	1
DRAINAGE AREA MAP	5
HYDRAULIC DATA	6
TOP OF DAM PROFILE	8
TYPICAL CROSS SECTIONS	9
SPILLWAY PROFILE	10
SPILLWAY RATING	11
OUTLET RATING	15
HEC-1 ANALYSIS	18

CHECK LIST FOR DAMS
HYDROLOGIC AND HYDRAULIC
ENGINEERING DATA

AREA-CAPACITY DATA:

	<u>Elevation (ft.)</u>	<u>Surface Area (acres)</u>	<u>Storage Capacity (acre-ft.)</u>
1) Top of Dam	999.9	18.0	259
2) Design High Water (Max. Design Pool)	-	-	-
3) Auxiliary Spillway Crest	999.1	17.2	246
4) Pool Level with Flashboards	-	-	-
5) Service Spillway Crest	997.1	12.9	216

DISCHARGES

	<u>Volume (cfs)</u>
1) Average Daily	10
2) Spillway @ Maximum High Water - Top of Dam -	149
3) Spillway @ Design High Water	-
4) Spillway @ Auxiliary Spillway Crest Elevation	109
5) Low Level Outlet	-
6) Total (of all facilities) @ Maximum High Water	186
7) Maximum Known Flood	Unknown
8) At Time of Inspection	2

*All elevations are referenced to a Temporary Bench Mark (T.B.M.) located on the top of the left upstream corner of the concrete slab over the spillway, with an assumed elevation of 1000.0 ft.

CREST:

ELEVATION: 999.9 ft. T.B.M.

Type: Concrete cap keyed into masonry and concrete core.

Width: 4.6 ft. Length: 248 ft. (incl. srv. spillway)

Spillover Service spillway and auxiliary spillway.

Location Service spillway at center of dam, auxiliary spillway left of left abutment of dam.

SPILLWAY:

SERVICE

AUXILIARY

<u>997.1 ft. T.B.M.</u>	Elevation	<u>999.1 ft. T.B.M.</u>
<u>Concrete weir 2 ft. high, 2.5 ft. wide in a rectangular masonry and concrete control section.</u>	Type	<u>Natural depression, approximately trapezoidal-shaped.</u>
<u>14 ft.</u>	Width	<u>20 ft. (approx.) bottom width 40 ft. at top of dam elevation</u>

Type of Control

X

Uncontrolled

X

Controlled:

-

Type

-

(Flashboards; gate)

Number

Size/Length

Invert Material

Anticipated Length of Operating Service

Chute Length

Height Between Spillway Crest & Approach Channel Invert (Weir Flow)

HYDROMETEROLOGICAL GAGES:

Type: None

Location: _____

Records:

Date: _____

Max. Reading: _____

FLOOD WATER CONTROL SYSTEM:

Warning System: None

Method of Controlled Releases (mechanisms):

Water in the reservoir can be released by means of a 1 ft. diameter drain pipe
with a control gate, although this pipe is not technically part of a "Flood
Water Control System."

DRAINAGE AREA: 0.22 sq. mi.

DRAINAGE BASIN RUNOFF CHARACTERISTICS:

Land Use - Type: 91% wooded, 9% lake surface.

Terrain - Relief: Average slope 15%.

Surface - Soil: Poor permeability.

Runoff Potential (existing or planned extensive alterations to existing surface or subsurface conditions)

None

Potential Sedimentation problem areas (natural or man-made; present or future)

No sedimentation problems exist or are expected due to the heavy vegetation covering the entire watershed.

Potential Backwater problem areas for levels at maximum storage capacity including surcharge storage:

None

Dikes - Floodwalls (overflow & non-overflow) - Low reaches along the Reservoir perimeter:

Location: None

Elevation: _____

Reservoir:

Length @ Maximum Pool 2,300 ft.

Length of Shoreline (@ Spillway Crest) 5,400 ft.

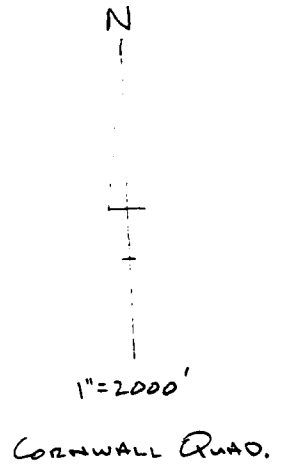
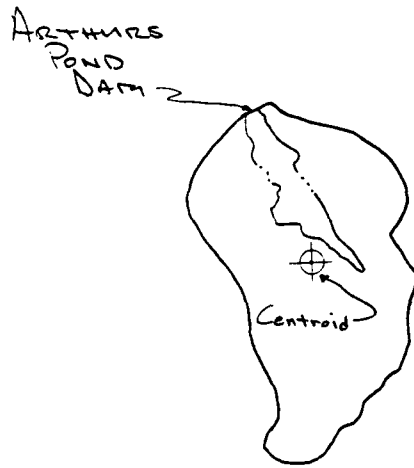

ARTHURS POND DAM
DRAINAGE AREA MAP

Drainage Area $1.55 \text{ in}^2 - 142.33 \text{ Ac} - 0.22 \text{ mi}^2$ (D.A. is all woodlands)

SURFACE AREA:

Lake (est elev. 1232±) - 12.86 Ac @ el. (997.1)
Elev. 1240 - 27.55 Ac @ el. (1005.1)
" 1260 - 47.14 Ac @ el. (1025.1)

$L = 4800 \text{ Ft.} = 0.91 \text{ mi}$

$LCA = 1700 \text{ Ft.} = 0.32 \text{ mi}$

Note: to equate field notes to approx. MSL -
Field notes el. (997.1) ±
Quad Sheet el. 1232.0'
diff 234.9'

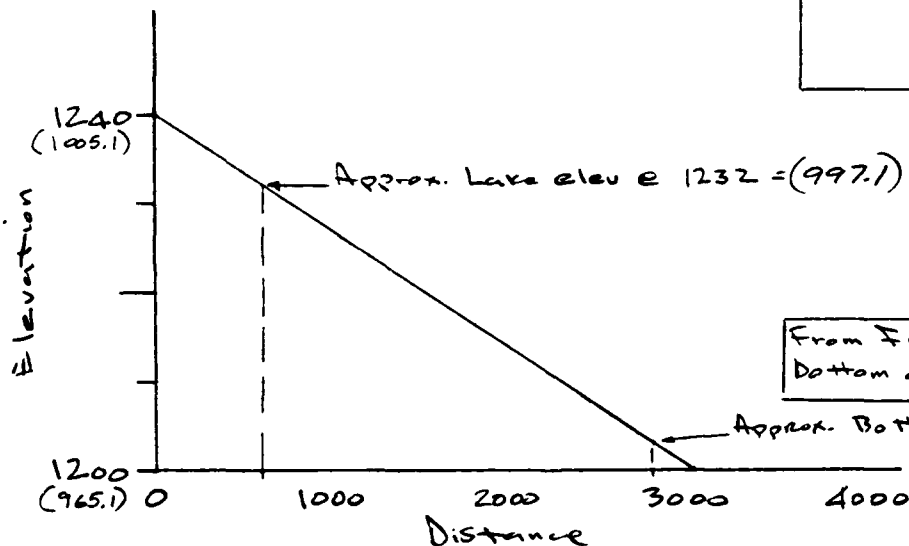

From Field notes: assume
Bottom of reservoir @ 976.0 el.

PRECIPITATION DATA

HMR-33 ZONE 1

PMP 24 hr. - 200 mi² - 21.5 in.

Drainage Area - 0.22 mi²

	ZONE 1 - Less than 10 mi ²	
6 hr. PMP	111%	= 23.87 in
12 hr. "	123%	= 26.45 in
24 hr. "	133%	= 28.60 in
48 hr. "	142%	= 30.53 in

TP-40

100 yr - 24 hr. Rainfall = 7.5 inches
" 17 hr " = 6.4 "

100 yr. - 6 hr. = 5.4 inches

MICHAEL BAKER, JR., INC.
THE BAKER ENGINEERS

Box 280
Beaver, Pa. 15009

Subject New York Dams S.O. No. _____
Arthur Pond Dam Sheet No. 7 of 29
Drawing No. _____
Computed by LAD Checked by JAQ Date 2/4/81

Snyder's Unit Hydrograph Coefficients

$$C_p = 0.63 \quad L = 0.91 \text{ Mi.}$$

$$C_T = 2.0 \quad L_{CA} = 0.32 \text{ Mi.}$$

$$\begin{aligned} T_P &= C_T (L \times L_{CA})^{0.3} \\ &= 2.0 (0.91 \times 0.32)^{0.3} \\ &= 1.38 \end{aligned}$$

Total Volume of Reservoir Storage

At El. 995.2 (Original Masonry Spillway Crest)
the Volume = 55.8 Million Gallons

$$55,800,000 \times .1337 = 7,460,460 \text{ cu. Ft.}$$

$$7,460,460 / 43,560 = 171.3 \text{ Ac.-Ft.}$$

$$\text{El. 995.2 Vol.} = 171.3 \text{ Ac.-Ft.}$$

$$\text{El. 997.1 Vol.} = 216.0 \text{ Ac.-Ft. (on HEC-1)}$$

MICHAEL BAKER, JR., INC.
THE BAKER ENGINEERS

Box 280
Beaver, Pa. 15009

Subject NEW YORK DAMS S.O. No. _____
DAM PROFILE Sheet No. 8 of 29
ARTHURS POND Drawing No. _____
 Computed by DCK Checked by WLS Date 1-13-81

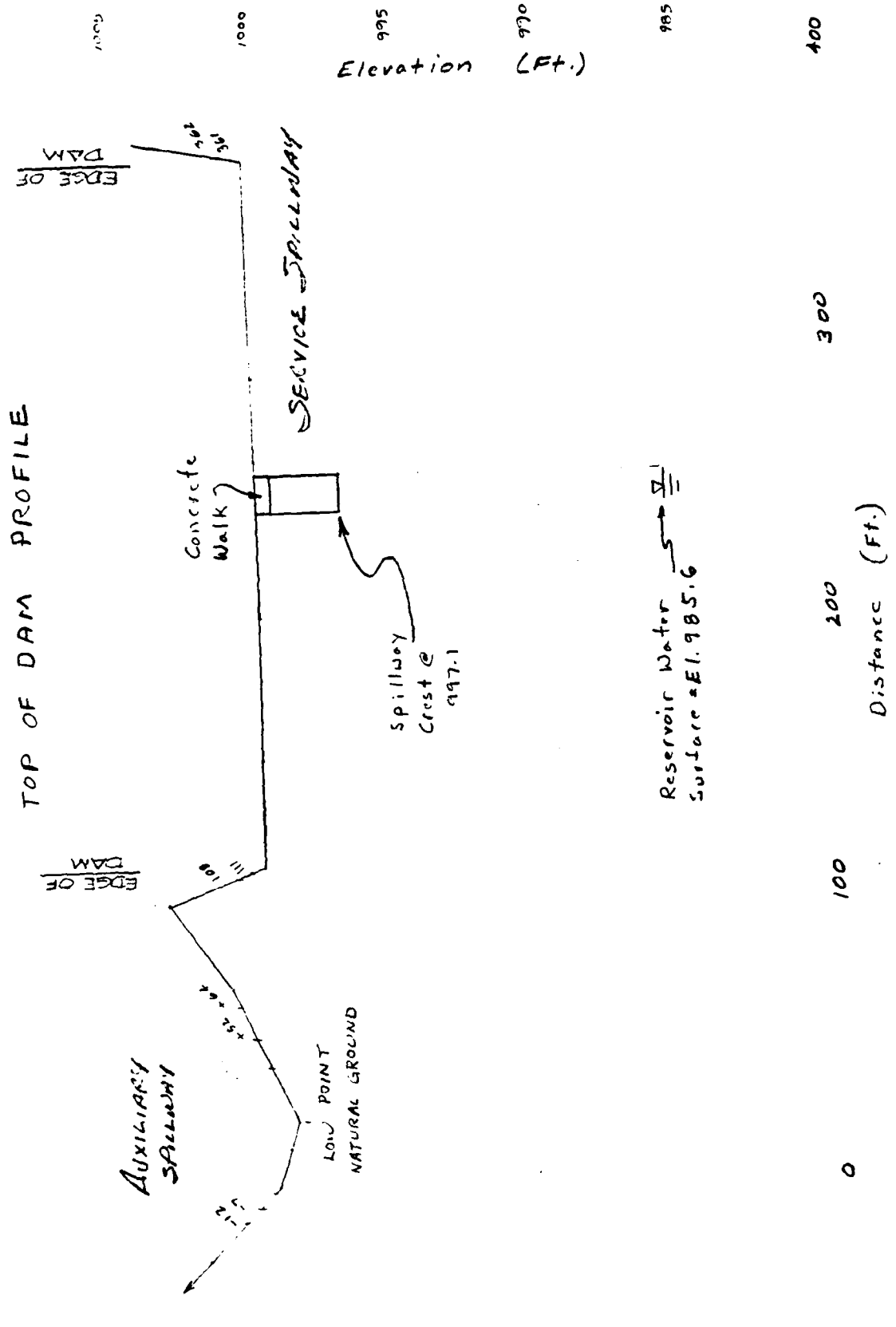

CROSS SECTION NO. 1 STA. 1+00

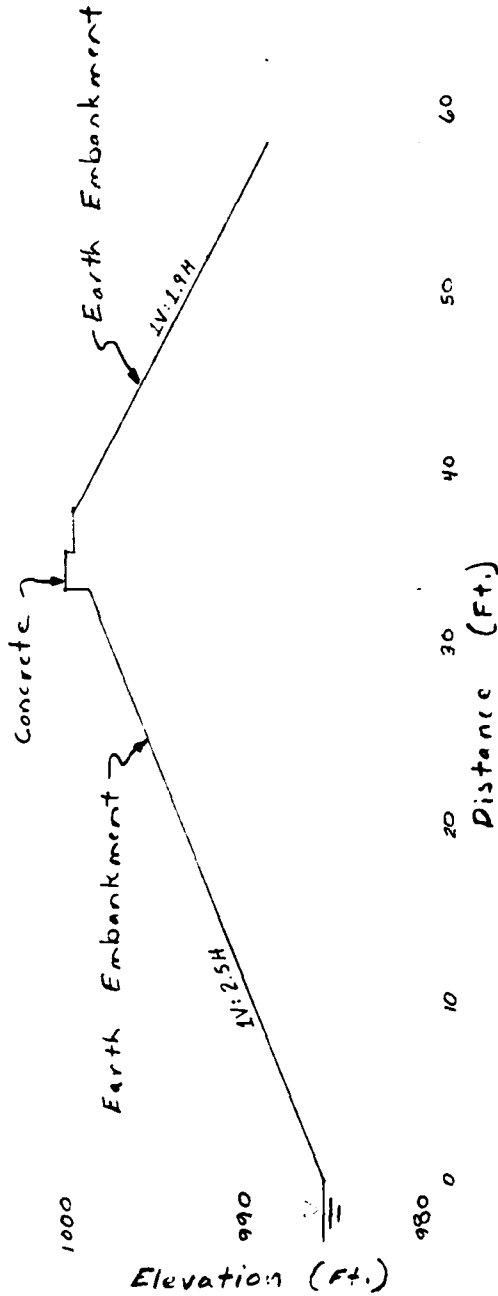

CROSS SECTION NO. 2 STA. 1+84
CENTER OF OUTLET WORKS

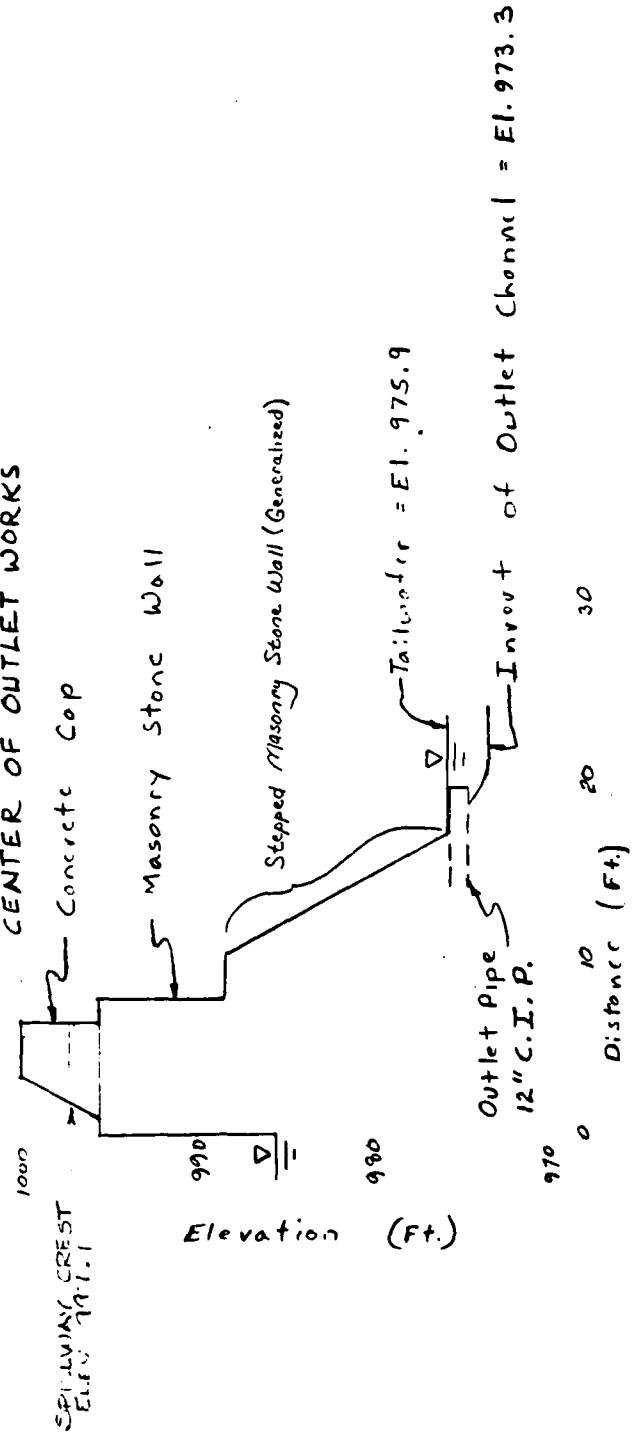

MICHAEL BAKER, JR., INC.

THE BAKER ENGINEERS

Box 280
Beaver, Pa. 15009

Subject New York Dams

Arthur's Pond Dam

Spillway

Computed by EM

Checked by JAQ

S.O. No. _____

Sheet No. 10 of 29

Drawing No. _____

Date 1/13/31

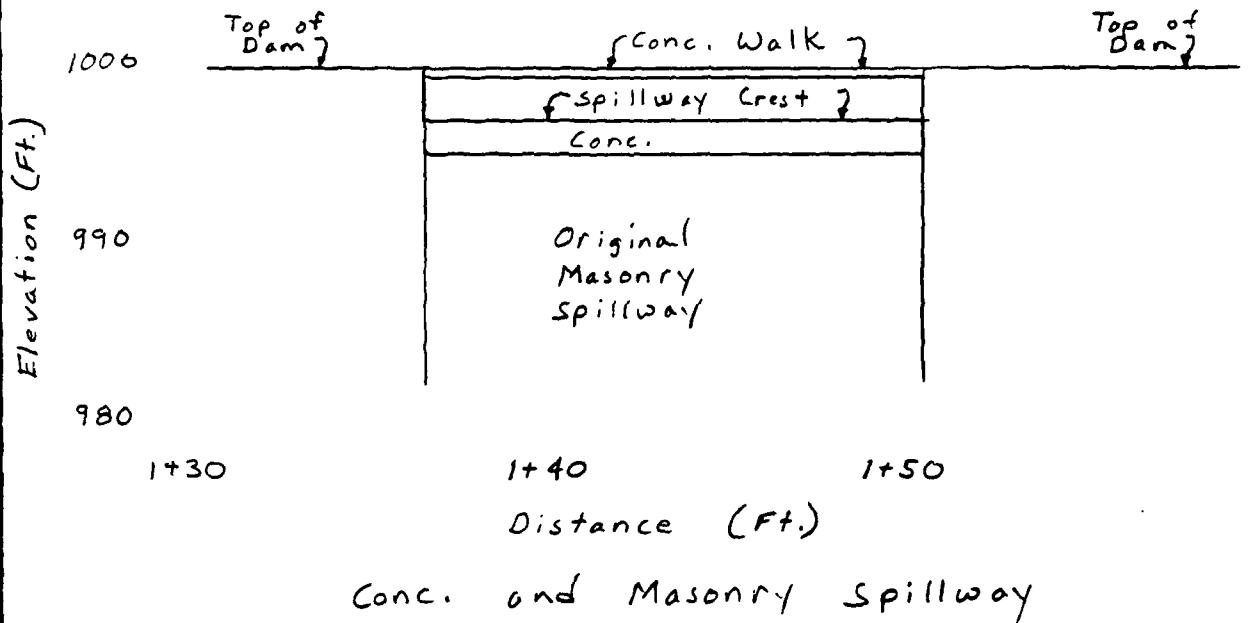
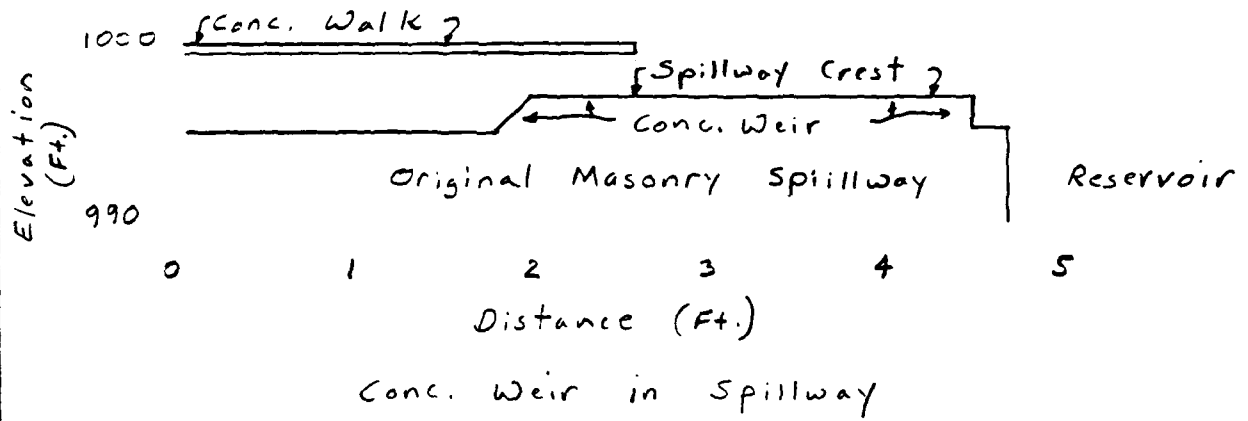

MICHAEL BAKER, JR., INC.

THE BAKER ENGINEERS

Box 280
Beaver, Pa. 15009

Subject New York Dams S.O. No. _____

Arthurs Pond Dam Sheet No. 11 of 29

Spillway Rating Drawing No. _____

Computed by LAD Checked by WLS Date 1/13/31
JAG

Weir Flow over Conc. Block

$$Q = CLH^{3/2}$$

H varies from 0 to 2.5 Ft.

C varies with H, King
and Brater Handbook
Pg 5-40 Table 5-3

L = 14 Ft.

Breadth of Crest = 2.5 Ft.

Elevation (Ft.)	H (Ft.)	C	L (Ft.)	Q (cfs)
997.1	0	0	14.0	0
997.5	0.4	2.60	14.0	9.2
998.0	0.9	2.62	14.0	31.3
998.5	1.4	2.68	14.0	62.2
999.0	1.9	2.75	14.0	100.6
999.5	2.4	2.86	14.0	148.9

MICHAEL BAKER, JR., INC.
THE BAKER ENGINEERS

Box 280
Beaver, Pa. 15009

Subject WILL 1672 TUNNEL S.O. No. _____
ABANDONED PORT DAM Sheet No. 12 of 29
CERT. DESIGN RATING FOR NAT. LOAD AREA Drawing No. _____
Computed by WLS Checked by JAQ Date 1/30/81

DAM ELEVATION (FT.)	DEPTH (FT.)	AREA (SQ. FT.)	T (FT.)	HYDRAULIC DEPTH		VELOCITY $V = \sqrt{gD}$ (FPS)	FLOW $Q = AV$ (CFS)	HEAD LOSS $H = V^2/2g$ (FT.)	RESERVOIR ELEVATION
				$D = A/T$ (FT.)	$D = A/T$ (FT.)				
999.1	0	0	0	0	0	0	0	0	999.1
999.2	0.1	0.3	5.3	0.06	1.4	0.4	0.03	0.03	999.2
999.5	0.4	4.3	21.3	0.20	2.5	10.8	0.10	0.10	999.6
999.8	0.7	13.1	37.3	0.35	3.4	44.5	0.18	0.18	1000.0
1000.0	0.9	21.2	43.4	0.49	4.0	84.8	0.25	0.25	1000.2
1000.5	1.4	16.6	58.5	0.80	5.1	237.7	0.40	0.40	1000.9
1001.0	1.9	79.6	73.6	1.08	5.9	469.6	0.54	0.54	1001.5
1001.4	2.3	111.5	85.7	1.30	6.5	724.8	0.66	0.66	1002.1
1002.0	2.9	167.3	100.2	1.67	7.3	1221.3	0.83	0.83	1002.8
1002.5	3.4	220.3	112.2	1.96	7.9	1740.4	0.97	0.97	1003.5
1003.0	3.9	279.4	124.2	2.25	8.5	2374.9	1.12	1.12	1004.1
1003.5	4.4	344.6	136.3	2.53	9.0	3101.4	1.26	1.26	1004.8

MICHAEL BAKER, JR., INC.
THE BAKER ENGINEERS

Box 280
Beaver, Pa. 15009

Subject NEW YORK DAMS

ARTHURS POND DAM

RES. EL. - DISC. GRAPH FOR NAT. LOW AREA

S.O. No. _____

Sheet No. 13 of 29

Drawing No. _____

Computed by WLS Checked by JAQ Date 1/20/81

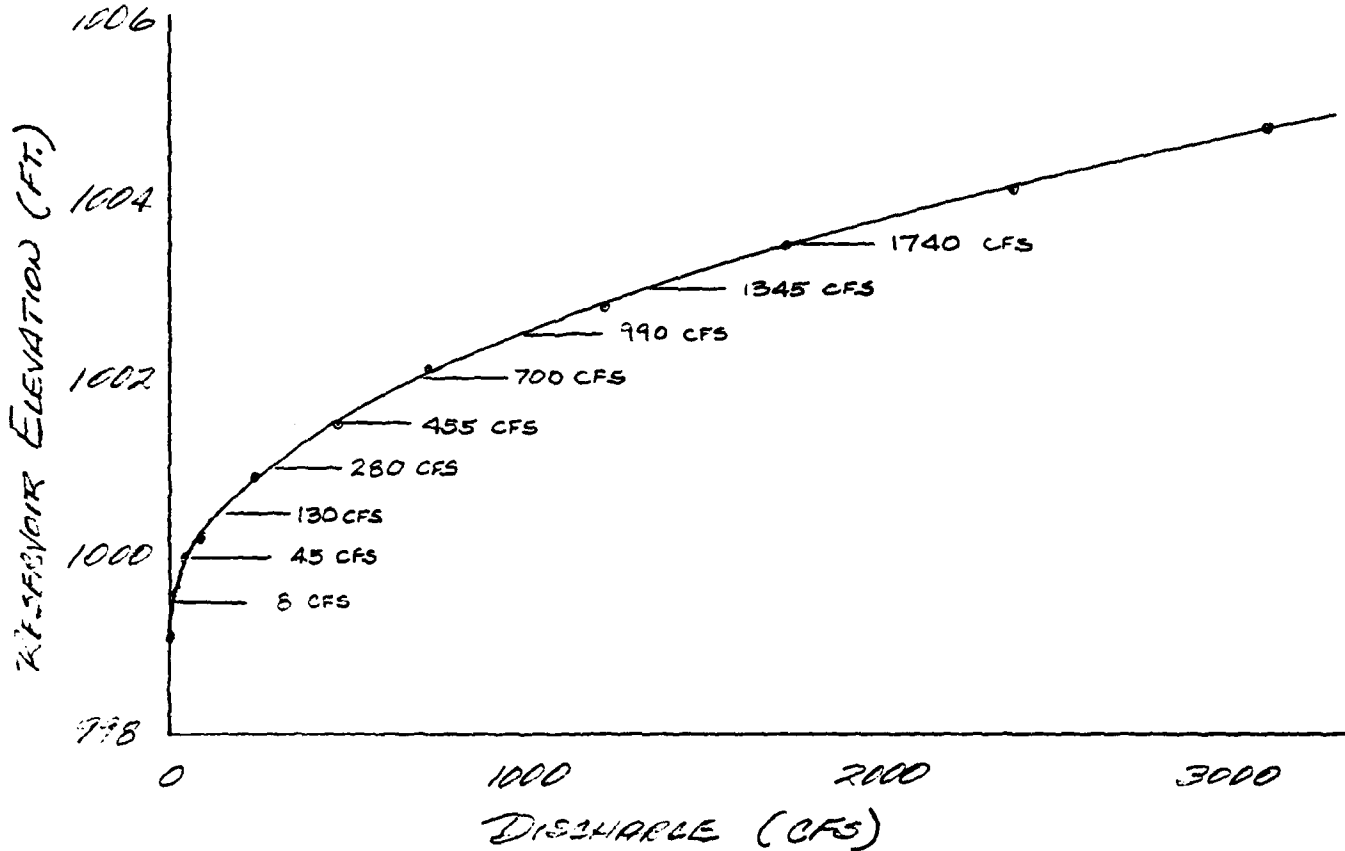

ELEVATION (FT.)	DISCHARGE (CFS)
999.0	0
999.5	8
1000.0	45
1000.5	130
1001.0	280
1001.5	455
1002.0	700
1002.5	990
1003.0	1345
1003.5	1740

NOTE: THE DISCHARGES AT THESE ELEVATIONS WERE TAKEN FROM THE ABOVE GRAPH TO BE ADDED TO THE SPILLWAY RATING

MICHAEL BAKER, JR., INC.

THE BAKER ENGINEERS

Box 280
Beaver, Pa. 15009

Subject NEW YORK DAMS

S.O. No. _____

ARTHURS POND DAM

Sheet No. 14 of 29

COMBINED SPILLWAY RATINGS

Drawing No. _____

Computed by WLS

Checked by JAQ

Date 1/25/81

ELEVATION (FT.)	DISCHARGE		TOTAL DISCHARGE (CFS)
	SPILLWAY (CFS)	NAT. LOW AREA (CFS)	
997.1	0	—	— 0
997.5	9.2	—	9.2
998.0	31.3	—	31.3
998.5	62.2	—	62.2
999.0	100.8	0	100.8
999.5	148.9	8	156.9
1000.0	148.9	45	193.9
1000.5	148.9	130	278.9
1001.0	148.9	280	428.9
1001.5	148.9	455	603.9
1002.0	148.9	700	848.9
1002.5	148.9	990	1138.9
1003.0	148.9	1345	1493.9
1003.5	148.9	1740	1888.9

Flow in Pipes Partly Full

"Design of Small Dams" Pg 558 and 559

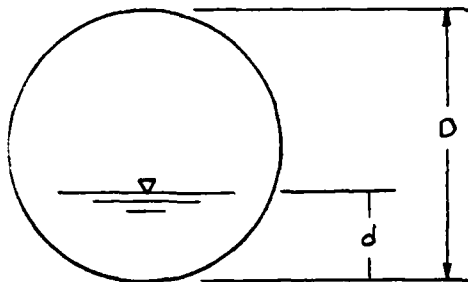

P = Cast Iron

D = Dia. Pipe = 12 in = 1 Ft.

d = Depth of Flow

S = slope of Pipe

$$= \frac{976.2 - 974.8}{20'} = .07$$

n = 0.014

$$\frac{d}{D} = \frac{.3}{1.0} = .3 \quad .5225 = \frac{Q_c}{D^{5/2}} = \frac{Q_c}{1^{5/2}} \quad Q_c = .52 \text{ cfs} \checkmark$$

$$\frac{d}{D} = \frac{.3}{1.0} = .3 \quad .0907 = \frac{Q n}{D^{8/3} S^{1/2}} = \frac{Q (.014)}{(1)^{8/3} (.07)^{1/2}} \quad Q = 1.71 \text{ cfs} \checkmark$$

$$\frac{d}{D} = \frac{.7}{1.0} = .7 \quad 2.6656 = \frac{Q_c}{D^{5/2}} = \frac{Q_c}{1^{5/2}} \quad Q_c = 2.67 \text{ cfs} \checkmark$$

$$\frac{d}{D} = \frac{.7}{1.0} = .7 \quad .388 = \frac{Q n}{D^{8/3} S^{1/2}} = \frac{Q (.014)}{(1)^{8/3} (.07)^{1/2}} \quad Q = 7.33 \text{ cfs} \checkmark$$

Pipe Invert at Entrance = El. 976.2 $Q = 0$

El. 976.5 $Q = .5 \text{ cfs}$

El. 976.9 $Q = 2.7 \text{ cfs}$

Critical Depth Controls

MICHAEL BAKER, JR., INC.
THE BAKER ENGINEERS

Box 280
Beaver, Pa. 15009

Subject New York Dams S.O. No. _____
Arthur's Pond Dam Sheet No. 16 of 29
Outlet Rating Drawing No. _____
Computed by LAD Checked by JAR Date 2/4/81

Orifice Flow

$$Q = CA(2gH)^{.5}$$

$$= 0.6(0.79)(64.4H)^{.5}$$

$$= 3.80(H)^{.5}$$

Pipe = 12" Cast Iron

$$A = \pi r^2 = 0.79 \text{ Sq. Ft.}$$

$$g = 32.2 \text{ Ft./sec.}$$

C = 0.6 King and Brater
Handbook Pg 4-32 Table 4-6

H varies from 0.8 Ft. to
20.4 Ft. and is measured
from the center of pipe
at inlet = El. 976.7

Elevation (Ft.)	H (Ft.)	Q (cfs)
977.5	0.8	3.4
978.0	1.3	4.3
979.0	2.3	5.8
980.0	3.3	6.9
981.0	4.3	7.9
982.0	5.3	8.7
983.0	6.3	9.6
984.0	7.3	10.3
985.0	8.3	11.0
986.0	9.3	11.6
987.0	10.3	12.2
988.0	11.3	12.8
989.0	12.3	13.3
990.0	13.3	13.9

Elevation (Ft.)	H (Ft.)	Q (cfs)
991.0	14.3	14.4
992.0	15.3	14.9
993.0	16.3	15.4
994.0	17.3	15.8
995.0	18.3	16.3
996.0	19.3	16.7
997.1	20.4	17.2

MICHAEL BAKER, JR., INC.

THE BAKER ENGINEERS

Box 280
Beaver, Pa. 15009Subject New York Dams

S.O. No. _____

Arthur's Pond DamSheet No. 17 of 29Outlet Rating

Drawing No. _____

Computed by LADChecked by JAQDate 2/5/81

Pipe Flow

$$Q = \frac{A(2gH)^{1/2}}{[1 + K_0 + K_p(L)]^{1/2}}$$

$$= \frac{0.79(64.4H)^{1/2}}{[1 + 0.78 + .0363(20)]^{1/2}}$$

$$= 4.00(H)^{1/2}$$

Pipe = 12" Cast Iron

 $A = \pi r^2 = 0.79 \text{ Sq. Ft.}$ $g = 32.2 \text{ Ft./sec}$ $L = 20 \text{ Ft.}$

Pipe Losses

Entrance Loss (K_0) = 0.78
Pg 5.5-6 SCS NEH-5Head Loss (K_p) = 0.0363
 $n = 0.014$ Pg 5.5-4
SCS NEH-5H varies from 3.2 Ft. to
22.8 Ft. and is measured
from the Top of Pipe
at Outlet = El. 974.3

Elevation (Ft.)	H (Ft.)	Q (cfs)
977.5	3.2	7.2
978.0	3.7	7.7
979.0	4.7	8.7
980.0	5.7	9.6
981.0	6.7	10.4
997.1	22.8	19.1

 FLD03 HYDROGRAPH PACKAGE 1.1--74
 DAM SAFETY VERSION JULY 1977
 LAST MODIFICATION 26 FEB 79
 493 UPDATE 06 JUN 77

R04 JATE 02/06/81
 TIME 15:37

NATIONAL PROGRAM FOR INSPECTION OF NON-FEDERAL DAMS
 HYDROLOGIC AND HYDRAULIC ANALYSIS OF AKHOK'S PUIHU DAM
 UNIT HYDROGRAPH BY SWYDERS METHOD

JOB SPECIFICATION

NO 500 NFR 5 THIR 5 JDAY 0 TRR 0 TRIN 0 RETRC 0 JPLT 0 JPRI 0 NSIAN 0
 JOPEK 5 MMT 0 LKOPT 0 TRAGE 0

MULTI-PLAN ANALYSES TO BE PERFORMED
 NPLAN= 1 NR1IU= 6 LR1IU= 1

RI1IU= 1.00 0.75 0.50 0.25

SUB-AREA RUNOFF COMPUTATION

RUNOFF HYDROGRAPH TO DAM

ESTAQ 1 ICORP 0 IECON 0 ITAPE 0 JPLT 0 JPRI 0 THARE 1 STAGE 1 AOUTU 0

HYDROGRAPH DATA

INVC 1 IJHG 1 TAKEA 1 SNAP 0.22 TRSDA 0.22 RATIO 0.00 ISNUM 0 ISAME 1 LOCAL 0

PRECIP DATA

SPL 6 PMS 6 K6 R1Z 424 K48 R72 K90
 0.0 21:50 111:00 123:00 133:00 142:00 0.0 0.0

LOSS DATA

LKOPT 0 STAKR 0 DLTKR 0 RIJUL 1.00 EHA1H 0.0 STKRS 1.00 K10K 1.00 UNSTL 0.10 ALSNK 0.00 RTIMP 0.00

UNIT HYDROGRAPH DATA

IP= 1.58 CP=0.03 NIA= 0

REGRESSION DATA

STKIU= -1.50 JRC3IF= 0.00 RTIUR= 2.00

UNIT HYDROGRAPH AT END-OF-PERIOD ORDINATES, LAG= 1.57 HOURS, CP= 0.03 YUL= 1.00

TIME	STKIU	YUL	RTIUR	CP	YUL
1.	4.	8.	12.	18.	23.
53.	27.	61.	66.	67.	67.
55.	31.	48.	42.	34.	31.
28.	27.	25.	22.	20.	19.
				18.	17.
				32.	30.
				50.	48.

d.

y.

y.

10.

11.

11.

12.

13.

14.

15.

11

PEAK FLOW AND STORAGE (END OF PERIOD) SUMMARY FOR MULTIPLE PLAN-RATIO ECONOMIC COMPUTATIONS
 FLOWS IN CUBIC FEET PER SECOND (CFS) METERS PER SECOND
 AREA IN SQUARE MILES (SQM) KILOMETERS²

RATIOS APPLIED TO FLOWS

OPERATION	STATION	AREA	PLAN RATIO	1 RATIO	2 RATIO	3 RATIO	4 RATIO
			1.00	0.75	0.50	0.25	
HYDROGRAPH AT	1	0.22	648	906	32%	102	4.5831
		0.571	18.351	13.751	9.171		
ROUTED TO	2	0.22	629	442	21%	92	
		0.571	17.831	12.531	6.211		2.701

SUMMARY OF DAM SAFETY ANALYSIS

PLAN 1	INITIAL VALUE	SPILLWAY CRIST	EUP OF DAM
LLVATION	97.10	97.10	99.70
STORAGE	216.	216.	257.
OUTFLOW	0.	0.	100.

RATIO OF P.F.	MAXIMUM DEPTH OVER DAM	MAXIMUM STORAGE AC-FT	MAXIMUM OUTFLOW CFS	DURATION OF P.F. HOURS	TIME OF MAX OUTFLOW HOURS	TIME OF FAILURE HOURS
1.00	0.70	271.	627.	4.58	41.08	0.0
0.75	0.52	258.	442.	3.87	41.33	0.0
0.50	0.17	262.	217.	2.00	42.33	0.0
0.25	0.0	243.	92.	0.0	42.67	0.0

1.01	12.00	2	14.00	0.	17.	200.	995.8
1.02	16.00	3	16.00	0.	16.	191.	995.1
1.03	0.00	4	24.00	0.	10.	103.	995.5
1.04	6.00	5	30.00	0.	16.	176.	993.8
1.05	12.00	6	36.00	0.	15.	168.	993.2
1.06	18.00	7	42.00	0.	15.	160.	992.5
1.07	0.00	8	48.00	0.	13.	122.	991.9
1.08	6.00	9	54.00	0.	13.	120.	991.3
1.09	12.00	10	60.00	0.	14.	131.	990.6
1.10	18.00	11	66.00	0.	14.	125.	989.4
1.11	0.00	12	72.00	0.	13.	118.	988.8
1.12	6.00	13	78.00	0.	13.	111.	988.2
1.13	12.00	14	84.00	0.	13.	105.	987.6
1.14	18.00	15	90.00	0.	12.	99.	987.0
1.15	0.00	16	96.00	0.	12.	93.	986.4
1.16	6.00	17	102.00	0.	12.	87.	985.9
1.17	12.00	18	108.00	0.	11.	82.	985.3
1.18	18.00	19	114.00	0.	11.	76.	984.7
1.19	0.00	20	120.00	0.	10.	71.	984.2
1.20	6.00	21	126.00	0.	10.	66.	983.7
1.21	12.00	22	132.00	0.	10.	61.	983.2
1.22	18.00	23	138.00	0.	9.	56.	982.7
1.23	0.00	24	144.00	0.	9.	52.	982.2
1.24	6.00	25	150.00	0.	9.	47.	981.7
1.25	12.00	26	156.00	0.	8.	43.	981.2
1.26	18.00	27	162.00	0.	8.	39.	980.8
1.27	0.00	28	168.00	0.	7.	35.	980.4
1.28	6.00	29	174.00	0.	7.	32.	980.0
1.29	12.00	30	180.00	0.	6.	29.	979.6
1.30	18.00	31	186.00	0.	6.	25.	979.3
1.31	0.00	32	192.00	0.	6.	23.	978.9
1.32	6.00	33	198.00	0.	5.	20.	978.6
1.33	12.00	34	204.00	0.	5.	18.	978.3
1.34	18.00	35	210.00	0.	4.	15.	978.1
1.35	0.00	36	216.00	0.	4.	13.	977.8
1.36	6.00	37	222.00	0.	4.	11.	977.6
1.37	12.00	38	228.00	0.	3.	10.	977.4
1.38	18.00	39	234.00	0.	3.	9.	977.2
1.39	0.00	40	240.00	0.	3.	7.	977.0
1.40	6.00	41	246.00	0.	2.	5.	976.9
1.41	12.00	42	252.00	0.	2.	4.	976.7
1.42	18.00	43	258.00	0.	1.	4.	976.6
1.43	0.00	44	264.00	0.	1.	3.	976.6
1.44	6.00	45	270.00	0.	1.	3.	976.5
1.45	12.00	46	276.00	0.	0.	2.	976.5
1.46	18.00	47	282.00	0.	0.	2.	976.5
1.47	0.00	48	288.00	0.	0.	2.	976.4
1.48	6.00	49	294.00	0.	0.	2.	976.4
1.49	12.00	50	300.00	0.	0.	2.	976.3
1.50	18.00	51	306.00	0.	0.	2.	976.3
1.51	0.00	52	312.00	0.	0.	1.	976.3
1.52	6.00	53	318.00	0.	0.	1.	976.3
1.53	12.00	54	324.00	0.	0.	1.	976.3
1.54	18.00	55	330.00	0.	0.	1.	976.3
1.55	0.00	56	336.00	0.	0.	1.	976.3
1.56	6.00	57	342.00	0.	0.	1.	976.3
1.57	12.00	58	348.00	0.	0.	1.	976.3
1.58	18.00	59	354.00	0.	0.	1.	976.3
1.59	0.00	60	360.00	0.	0.	1.	976.3
1.60	6.00	61	366.00	0.	0.	1.	976.3
1.61	12.00	62	372.00	0.	0.	1.	976.3
1.62	18.00	63	378.00	0.	0.	1.	976.3
1.63	0.00	64	384.00	0.	0.	1.	976.3
1.64	6.00	65	390.00	0.	0.	1.	976.2
1.65	12.00	66	396.00	0.	0.	1.	976.2
1.66	18.00	67	402.00	0.	0.	1.	976.2

SHEET 26 OF 29

11

LINE NO.	TIME	PEAK	6-HOUR	24-HOUR	72-HOUR	TOTAL VOLUME	976.2
1	1.18	0.0	68	408.00	0.	0.	976.2
2	1.18	6.00	69	414.00	0.	0.	976.2
3	1.18	12.00	70	420.00	0.	0.	976.2
4	1.18	18.00	71	426.00	0.	0.	976.2
5	1.19	0.0	72	432.00	0.	0.	976.2
6	1.19	6.00	73	438.00	0.	0.	976.2
7	1.19	12.00	74	444.00	0.	0.	976.2
8	1.19	18.00	75	450.00	0.	0.	976.2
9	1.20	0.0	76	456.00	0.	0.	976.2
10	1.20	6.00	77	462.00	0.	0.	976.2
11	1.20	12.00	78	468.00	0.	0.	976.2
12	1.20	18.00	79	474.00	0.	0.	976.2
13	1.21	0.0	80	480.00	0.	0.	976.2
14	1.21	6.00	81	486.00	0.	0.	976.2
15	1.21	12.00	82	492.00	0.	0.	976.2
16	1.21	18.00	83	498.00	0.	0.	976.2
17	1.22	0.0	84	504.00	0.	0.	976.2
18	1.22	6.00	85	510.00	0.	0.	976.2
19	1.22	12.00	86	516.00	0.	0.	976.2
20	1.22	18.00	87	522.00	0.	0.	976.2
21	1.23	0.0	88	528.00	0.	0.	976.2
22	1.23	6.00	89	534.00	0.	0.	976.2
23	1.23	12.00	90	540.00	0.	0.	976.2
24	1.23	18.00	91	546.00	0.	0.	976.2
25	1.24	0.0	92	552.00	0.	0.	976.2
26	1.24	6.00	93	558.00	0.	0.	976.2
27	1.24	12.00	94	564.00	0.	0.	976.2
28	1.24	18.00	95	570.00	0.	0.	976.2
29	1.25	0.0	96	576.00	0.	0.	976.2
30	1.25	6.00	97	582.00	0.	0.	976.2
31	1.25	12.00	98	588.00	0.	0.	976.2
32	1.25	18.00	99	594.00	0.	0.	976.2
33	1.26	0.0	100	600.00	0.	0.	976.2

PEAK OUTFLOW IS 17. AT 144E 0.0 HOURS

UNIT	PEAK	6-HOUR	24-HOUR	72-HOUR	TOTAL VOLUME
FS	17.	17.	16.	15.	619.
SMS	0.	0.	0.	0.	12.
INCHES	0.71	2.76	7.67	17.72	450.12
MM	17.99	70.06	194.80	408.	256.
AC-FT	8.	34.	40.	111.	256.
THOUS UH	10.	40.	111.	256.	256.

SUMMARY OF DAM SAFETY ANALYSIS

NO.	DESCRIPTION	INITIAL VALUE	SPILLWAY GROSS	TOP OF DAM	TIME OF FAILURE HOURS
1	PLAN I	997.10	997.10	997.90	0.0
2	ELEVATION STORAGE	216.	216.	259.	0.0
3	OUTFLOW	17.	17.	18.	0.0
4	RATIO OF PMF	1.00	17.	18.	0.0
5	MAXIMUM DEPTH OVER DAM	0.0	17.	18.	0.0
6	MAXIMUM STORAGE AC-FT	216.	17.	18.	0.0
7	MAXIMUM OUTFLOW CFS	17.	17.	18.	0.0
8	MAXIMUM DURATION OVER TOP HOURS	0.0	17.	18.	0.0
9	TIME OF FAILURE HOURS	0.0	17.	18.	0.0
10					
11					
12					
13					
14					
15					
16					
17					
18					
19					
20					
21					
22					
23					
24					
25					
26					
27					
28					
29					
30					
31					
32					
33					
34					
35					
36					
37					
38					
39					
40					
41					
42					
43					
44					
45					
46					
47					
48					
49					
50					
51					
52					
53					
54					
55					
56					
57					
58					
59					
60					
61					
62					
63					
64					
65					
66					
67					
68					
69					
70					
71					
72					
73					
74					
75					
76					
77					
78					
79					
80					
81					
82					
83					
84					
85					
86					
87					
88					
89					
90					
91					
92					
93					
94					
95					
96					
97					
98					
99					
100					

SHEET 29 OF 29

APPENDIX D
STABILITY COMPUTATIONS

Stability of the Dam Material

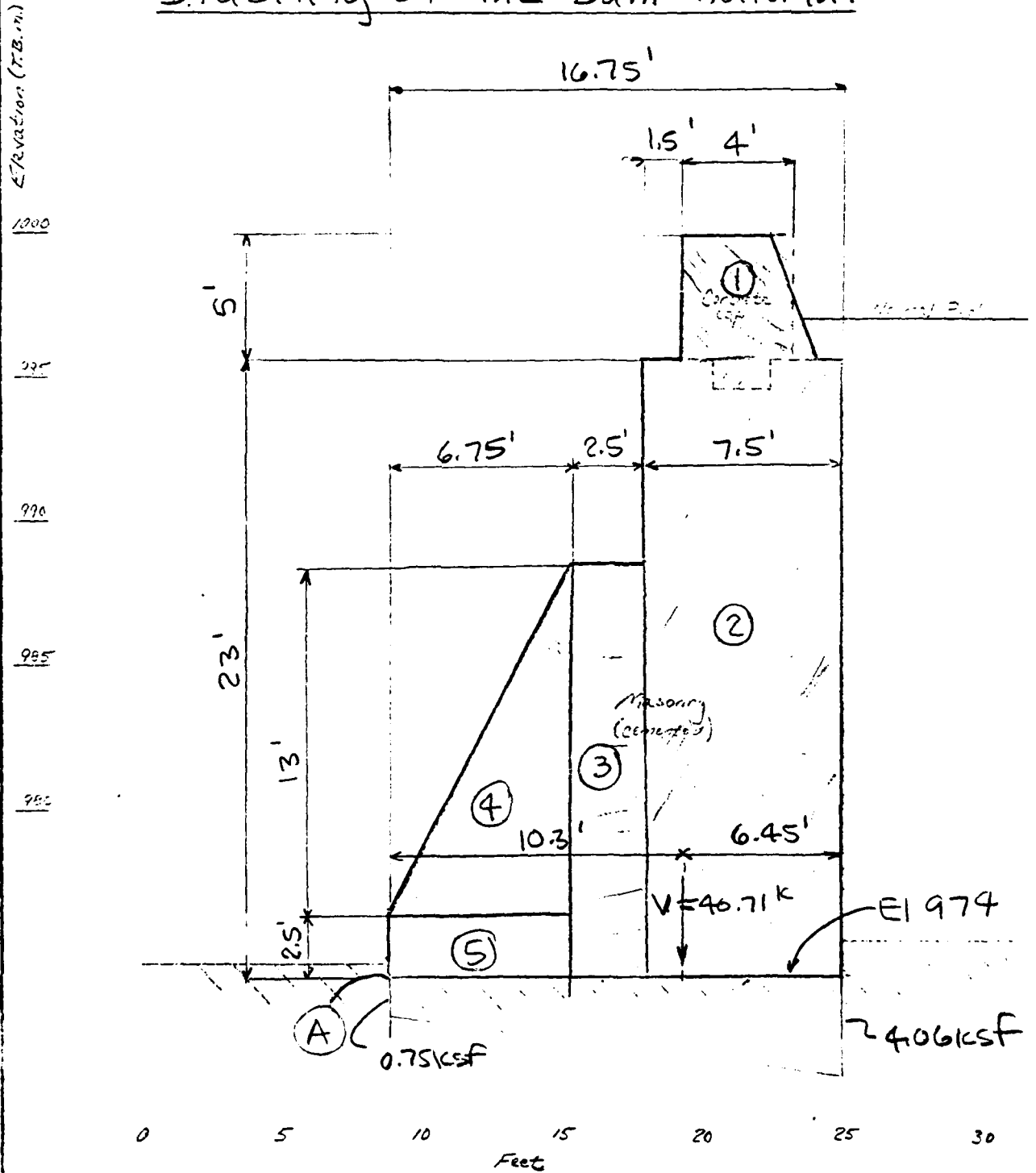

THE BAKER ENGINEERS

Box 250
P.O. Box 1110

Subject: FEEDBACK POND DAM

STABILITY ANALYSIS

CROSS-SECTION / NORMAL POOL SECTION

Checked by: ZSM/JT

S.O. No. 13885

Sheet No. 2 of 10

Drawing No. AP2

Date Feb 1981

Elevation (F.T.)

1000
995
990
985
980

Case 1

Normal Operating
Conditions, Full
Uplift, Water at
Reservoir Level.

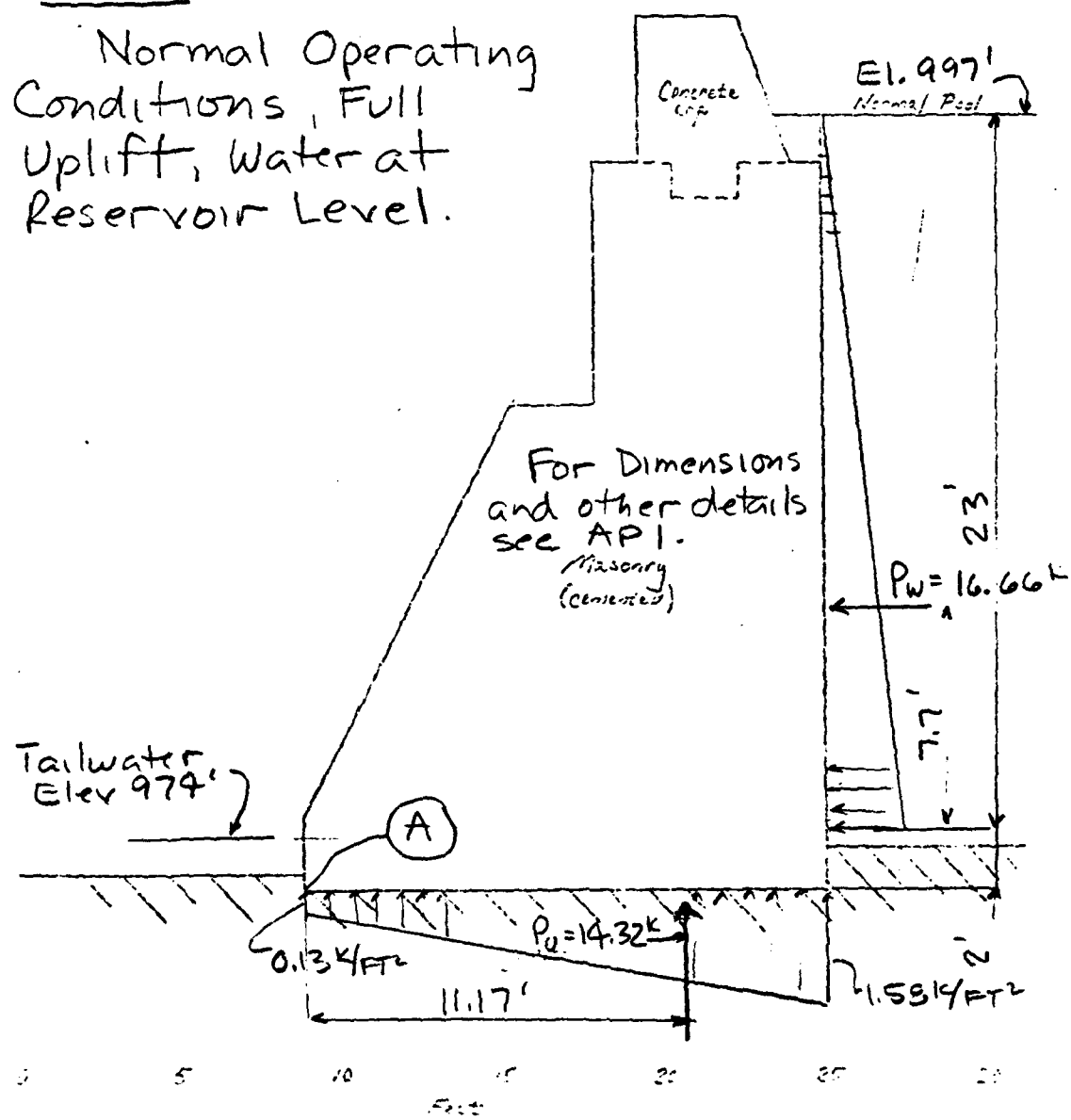

For Dimensions
and other details
see AP1.
Masonry
(concrete)

Tailwater
Elev 974'

(A)

0.13k/ft²

$P_u = 14.32k$

11.17'

$P_w = 16.66k$

7.7'

1.53k/ft²

Feet

Stability of Dam Section EM at Point (A)

	W	Dist From Toe	M
① 4' x 4.7' x 0.14	2.63k	12.75'	33.6'k
② 23' x 7.5' x 0.14	24.15k	12.75'	308'k
③ 15.5' x 2.5' x 0.14	5.43k	8.0'	43.4'k
④ $\frac{1}{2}(13 \times 6.75') \times 0.14$	6.14k	4.5'	27.6'k
⑤ 2.5' x 6.75' x 0.14	<u>2.36k</u>	3.38'	<u>8.0'k</u>
	40.71k		421.

$$\bar{x} = 421'k \div 40.71k = 10.3'$$

Middle Third = 5.58' to 11.16'

Case 1 - Normal Operating Condition will full uplift and water at reservoir level.

	w	arm	M
Σ ① to ⑤	40.71 ↓		421'k
Uplift P_u	-14.32 ↑	11.17'	-160'k
Water Pr. P_w	<u>16.66 ←</u>	7.7'	<u>-129'k</u>

$$V = 26.39k \downarrow \quad 132'k$$

$$H = 16.66k \leftarrow \quad x = 132'k \div 26.39k = 5' \text{ NOT IN MIDDLE THIRD}$$

$$\frac{\Sigma H}{\Sigma V} = \frac{16.66k}{26.39k} = 0.63 \quad FS \text{ against OT} = \frac{421}{289} = 1.46 \leftarrow$$

Soil Pressure from Dam Section

$$e = 10.3 - \frac{16.75}{2} = 1.92 < \frac{16.75}{6} = 2.8$$

Therefore

$$\begin{aligned} p_i &= \left(\frac{P}{b} \right) \left(1 \pm \frac{6e}{b} \right) \\ &= \frac{40.71}{16.75} \left(1 \pm \frac{6 \times 1.92}{16.75} \right) \\ &= 2.4 (1 \pm 0.69) \end{aligned}$$

$$P_{min} = 0.75 \text{ ksf} \quad P_{max} = 4.06 \text{ ksf}$$

See API for Location

Soil Pressure from Case 1

$$e = \frac{16.75}{2} - 5 = 3.38' \quad \frac{16.75}{6} = 2.8 < 3.38$$

so part of foundation is uplifted

$$P = 26.39 \text{ k}$$

$$P = \frac{1}{2} (p_2 \times 15)$$

$$p_2 = 2P \div 15 = 3.52 \text{ ksf}$$

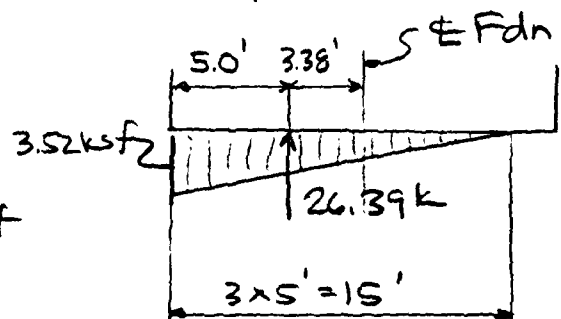

Case 2 - Same as Case 1 with the addition of Ice Loading

Assume 5k loading at about 24' above point (A).

$\Sigma M @$

	w	Arm	M
Case 1	↓ 26.39k ← 16.66k		132'k
Ice Load	← 5k	24	<u>-120'k</u> 12'k
	↓ 26.39k ← 21.66k		

$$\bar{x} = 12'k \div 26.39k = 0.45'$$

$$FS \text{ against OT} = \frac{421}{409} = 1.03$$

Soil Pressure

$$P = \frac{1}{2} \times 1.35' \times p_i$$

$$p_i = \frac{2P}{1.35} = 39 \text{ ksf}$$

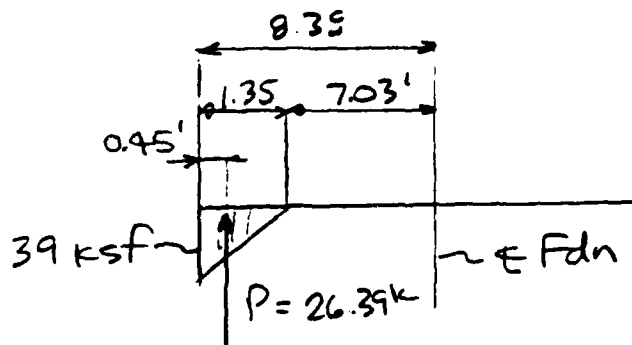

Case 3
ΣMA

	W	Arm	M
Σ ① to ⑤	40.71 k ↓		421' k
Uplift P _{u1}	4.2 k ↑	8.38' - 35' k	
P _{u2}	12.6 k ↑	11.17' - 141' k	
Water Pressure			
P ₁	24.6 k ←	9.0' - 221' k	
P ₂	1.5 k →	1.3' + 2' k	
			26' k
	↓ V = 23.9 k		
	← H = 23.1 k		
		X = 26' k ÷ 23.9 k = 1.08'	
		FS against OT = 423 ÷ 397 = 1.07 ←	

$$P = \frac{1}{2} \times 3.24' \times p_1$$

$$p_1 = \frac{2P}{3.24} = 14.8 \text{ ksf}$$

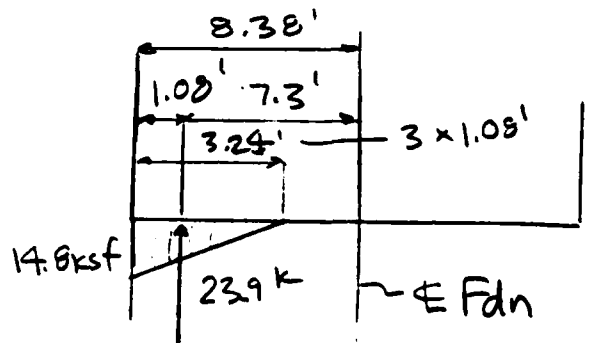

Case 4 - Reservoir Level 1/2 PMF, Full Uplift
 as in Case 1, and 6 feet of tailwater.

Elevation (F.S.M.)

1000
 975
 970
 935
 900

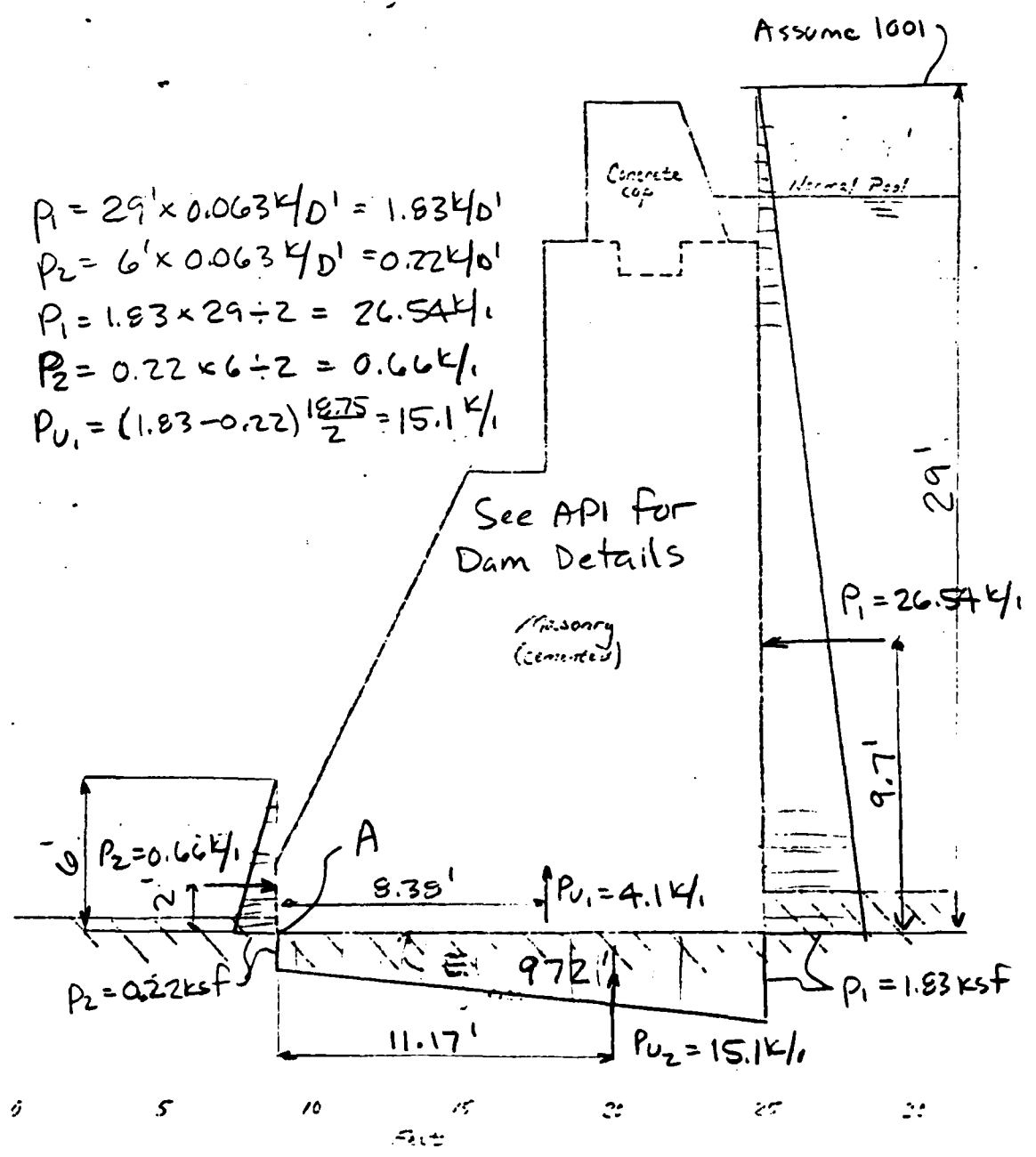

$$P_1 = 29' \times 0.063 k/10' = 1.83 k/10'$$

$$P_2 = 6' \times 0.063 k/10' = 0.22 k/10'$$

$$P_{1i} = 1.83 \times 29 \div 2 = 26.54 k/1$$

$$P_{2i} = 0.22 \times 6 \div 2 = 0.66 k/1$$

$$P_{u1} = (1.83 - 0.22) \frac{975}{2} = 15.1 k/1$$

MICHAEL BAKER, JR., INC.
THE BAKER ENGINEERS

Box 280
Beaver, Pa. 15009

Subject ARTHUR FOND DAM
STABILITY ANALYSIS
CONCRETE MASONRY MAX. SECTION

Computed by JT Checked by _____

S.O. No. 13583
Sheet No. 9 of 10
Ref. Drawing No. AP9
Date FEB 1981

Case 4

ΣMA	W ^k	Arm	M
$\Sigma \textcircled{1} \text{ to } \textcircled{5}$	40.71 \downarrow		421 'k
Uplift P_{u1}	4.1 $\text{k}\uparrow$	-8.38	-34 'k
P_{u2}	15.1 $\text{k}\uparrow$	-11.17	-169 'k
Water Pressure			
P_1	26.54 $\text{k}\leftarrow$	-9.7	-257 'k
P_2	0.66 $\text{k}\rightarrow$	+ 2.0	1 'k
	<u>21.51$\text{k}\downarrow$</u>		<u>-38'k</u>
	25.9 $\text{k}\leftarrow$		

Uplift
Occurs

$$\bar{X} = -38 \text{'k} \div 21.51 \text{k} = -1.77$$
$$FS \text{ against OT} = \frac{422}{460} = 0.92$$

MICHAEL BAKER, JR., INC.
THE BAKER ENGINEERS

Box 280
Beaver, Pa. 15009

Subject ARTHURS BOND DAM
STABILITY ANALYSIS

S.O. No. 13889
Sheet No. 10 of 10
Drawing No. API0

Computed by JAD Checked by JAD Date Feb 1981

Sliding Resistance $\alpha = 0^\circ$

$$\begin{aligned} R_R &= * V \tan \phi + c A \text{ (see note below)} \\ &= 26.39 \tan^{.7002} 35^\circ + (2.0 \text{ ksf} \times 16.75) \\ &= 18.5 \text{ k} + 33.5 \text{ k} \\ &= 52 \text{ k} \end{aligned}$$

* CASE 1: $V = 26.39$
CASE 2: $V = 26.55$
CASE 3: $V = 23.74$
CASE 4: $V = 21.59$

Factor of Safety against sliding

$$\text{CASE 1. } \frac{52}{16.7} = 3.11$$

$$\text{CASE 2 } \frac{52}{21.7} = 2.40$$

$$\text{CASE 3 } \frac{50.2}{23.1} = 2.17$$

$$\text{CASE 4. } \frac{48.6}{25.9} = 1.88$$

Note: 2.0 ksf is the value shown for the unconfined compressive strength of stiff clay on page 30 of Terzaghi & Peck (1967). This value was used as a conservative approximation of the shear strength of a weathered rock.

APPENDIX E
REFERENCES

REFERENCES

1. University of the State of New York, Geology of New York, Education Leaflet 20, 1966.
2. Broughton, John G. and others, "Geologic Map of New York - Lower Hudson Sheet," New York State Museum and Science Service, Map and Chart Series No. 15, 1970.
3. Dunbar, Carl O. and Waage, Karl M., Historical Geology, John Wiley and Sons, Inc., New York, 1969.
4. Soil Conservation Service, Soil Inventory and Their Interpretations for Specific Uses (Interim Report), Rockland County, New York, U.S. Department of Agriculture, August 1970.
5. Bureau of Reclamation, U.S. Dept. of the Interior, Design of Small Dams, A Water Resources Technical Publication, 1977.
6. Chow, Ven Te, Handbook of Applied Hydrology, McGraw - Hill Book Company, New York, 1964.
7. Chow, Ven Te, Open Channel Hydraulics, McGraw - Hill Book Company, New York, First Edition, 1959.
8. HMR 33, "Seasonal Variations of Probable Maximum Precipitation, East of the 105th Meridian for Areas 10 to 1000 Square Miles and Durations of 6 to 48 Hours," (1956).
9. King, Horace Williams and Brater, Ernest F., Handbook of Hydraulics, Fifth Edition, McGraw - Hill Book Company, New York, 1963.
10. Soil Conservation Service, "National Engineering Handbook - Section 4, Hydrology," U.S. Department of Agriculture, 1964.
11. Soil Conservation Service, "National Engineering Handbook - Section 5, Hydraulics," U.S. Department of Agriculture.
12. U.S. Army, Hydrological Engineering Center, "Flood Hydrograph Package (HEC-1), Dam Safety Investigations, Users Manual," Corps of Engineers, Davis, California, September 1978.
13. U.S. Army, Hydrological Engineering Center, "HEC-2 Water Surface Profiles, Users Manual," Corps of Engineers, Davis, California, October 1973.

14. U.S. Army, "Inventory of United States Dams," Corps of Engineers, 9 September 1978.
15. U.S. Army, Office of the Chief of Engineers, "Appendix D, Recommended Guidelines for Safety Inspection of Dams," National Program of Inspection of Dams, Volume 1, Corps of Engineers, Washington, D.C., May 1975.
16. George, Thomas S. and Taylor, Robert S., Hydrologic Flood Routing Model For Lower Hudson River Basin, Water Resources Engineers, Inc., 8001 Forbes Place, Suite 312, Springfield, Virginia, January 1977.
17. U.S. Army, Office of the Chief of Engineers, Engineering Circular EC-1110-2-163 (Draft Engineering Manual), "Spillway and Freeboard Requirements for Dams, Appendix C, Hydrometeorological Criteria and Hyetograph Estimates," (August 1975).
18. U.S. Army, Office of the Chief of Engineers, Engineering Circular EC-1110-2-188, "Engineering and Design, National Program of Inspection of Non-Federal Dams," Corps of Engineers, Washington, D.C., 30 December 1977.
19. U.S. Army, Office of the Chief of Engineers, Engineer Technical Letter No. ETL 1110-2-234, "Engineering and Design, National Program of Inspection of Non-Federal Dams, Review of Spillway Adequacy," Corps of Engineers, Washington, D.C., 10 May 1978.
20. U.S. Department of Commerce, "Technical Paper No. 40, Rainfall Frequency Atlas of the United States for Durations from 30 Minutes to 24 Hours and Return Periods from 1 to 100 Years," Weather Bureau, Washington, D.C., May 1961.
21. U.S. Department of Commerce, National Oceanic and Atmospheric Administration, "Hydrometeorological Report No. 51; Probable Maximum Precipitation Estimates, United States East of the 105th Meridian," Washington, D.C., June 1978.
22. Terzaghi, Karl and Peck, Ralph B., Soil Mechanics in Engineering Practice, 2d. ed., John Wiley & Sons, Inc., New York, 1967.

APPENDIX F
DRAWINGS

CONTENTS

Location Plan

Watershed Map

Plate 1: Field Sketch

Plate 2: Arthurs Pond Dam Alterations (1958)

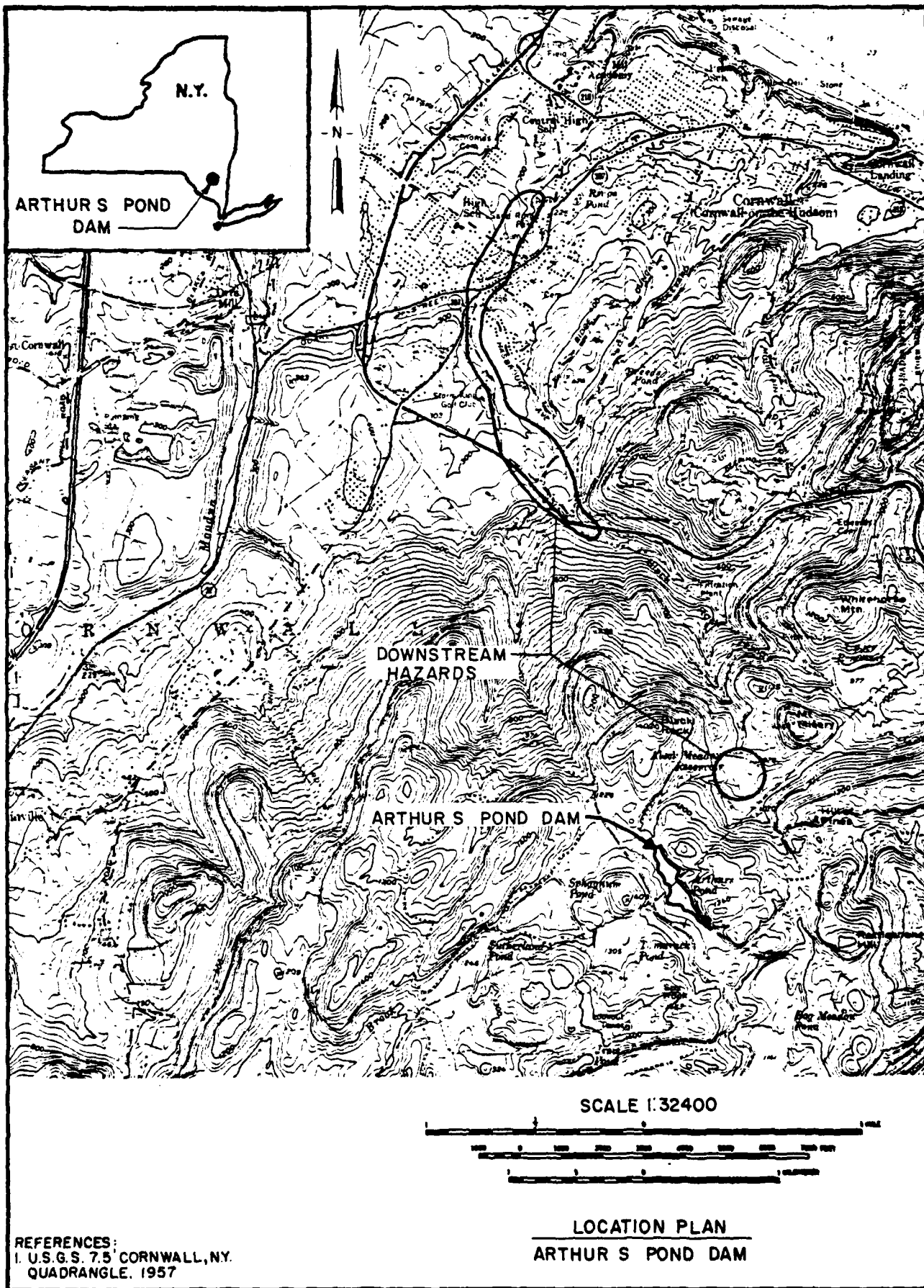

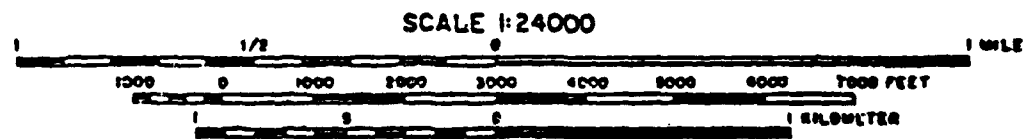
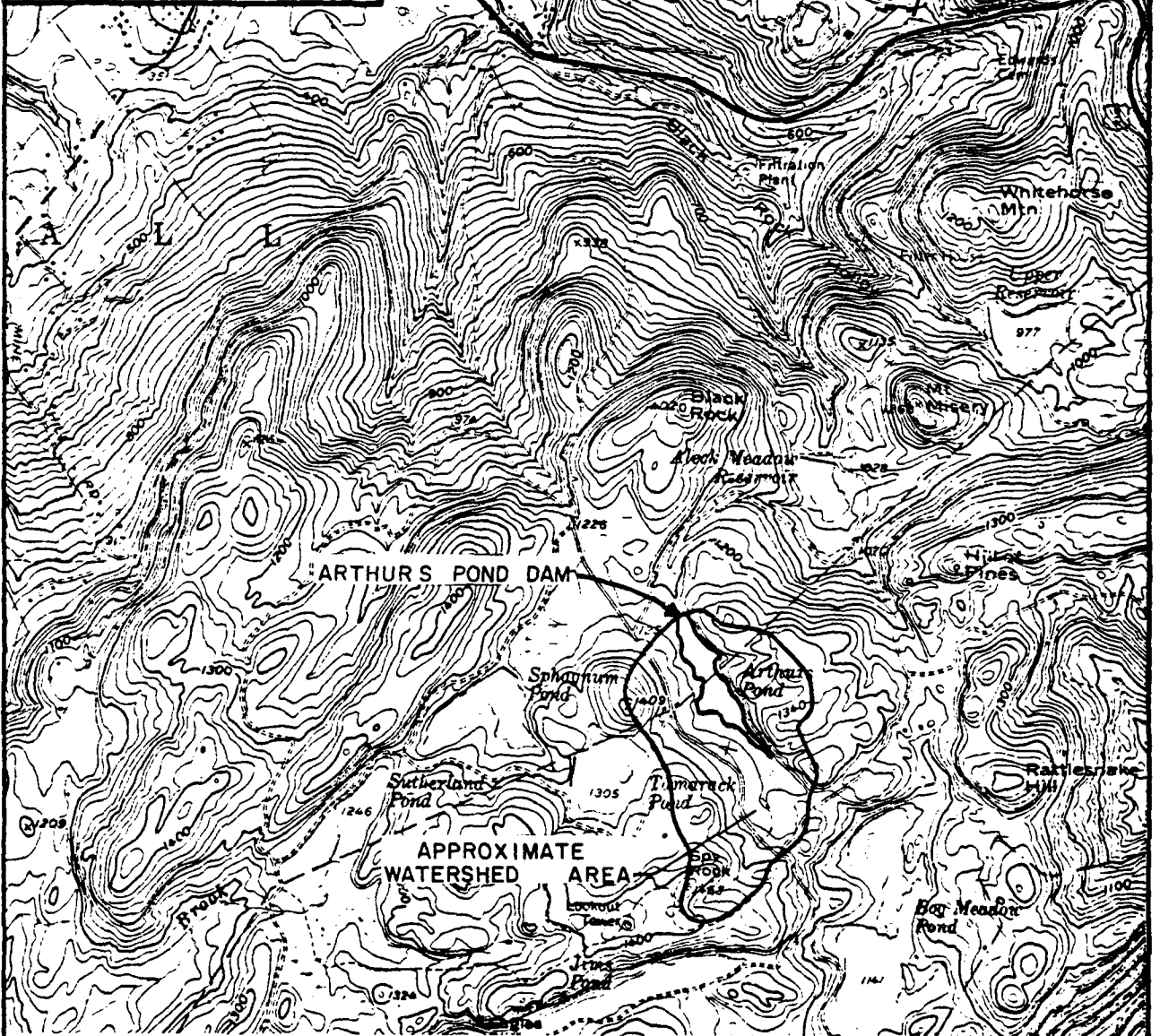
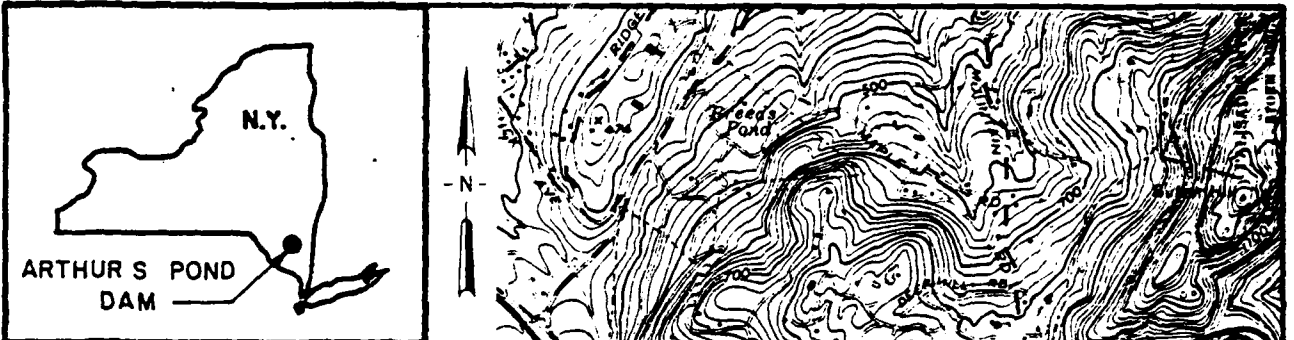

REFERENCES:
 1. U.S.G.S. 7.5' CORNWALL, N.Y.
 QUADRANGLE. 1957

WATERSHED MAP
ARTHUR'S POND DAM

AD-A105 767

BAKER (MICHAEL) JR INC BEAVER PA
NATIONAL DAM SAFETY PROGRAM. ARTHURS POND DAM (INVENTORY NUMBER--ETC(U)
JUN 81 6 KESTER

F/G 13/13

DACW51-81-C-0010

NL

UNCLASSIFIED

2



END
DATE
FILMED
11-81
DTIC

- Not to Scale -

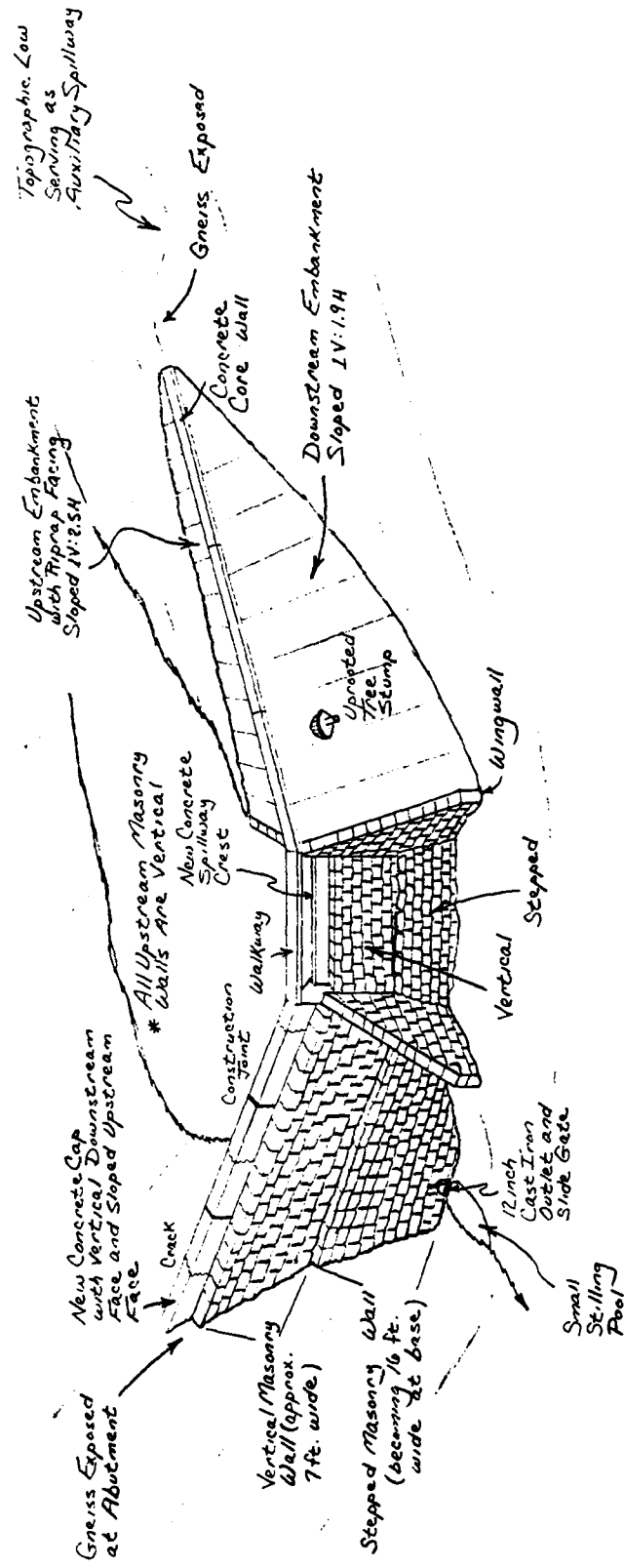

FIELD SKETCH
ARTHURS POND DAM, NEW YORK
Michael Baker, Jr., Inc.
8 January 1981
PLATE I

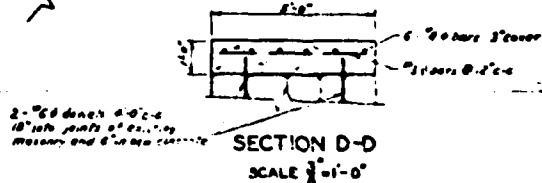
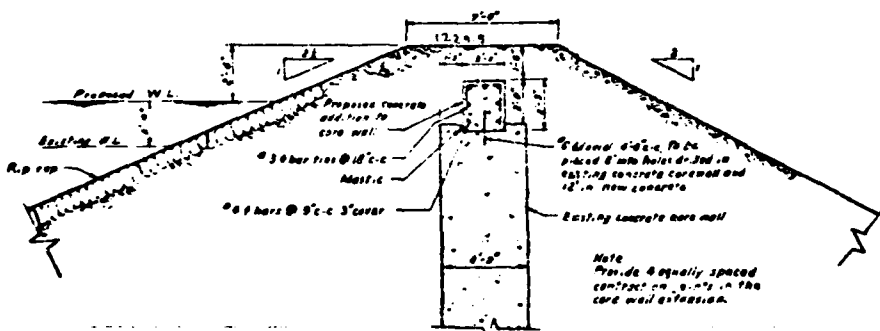
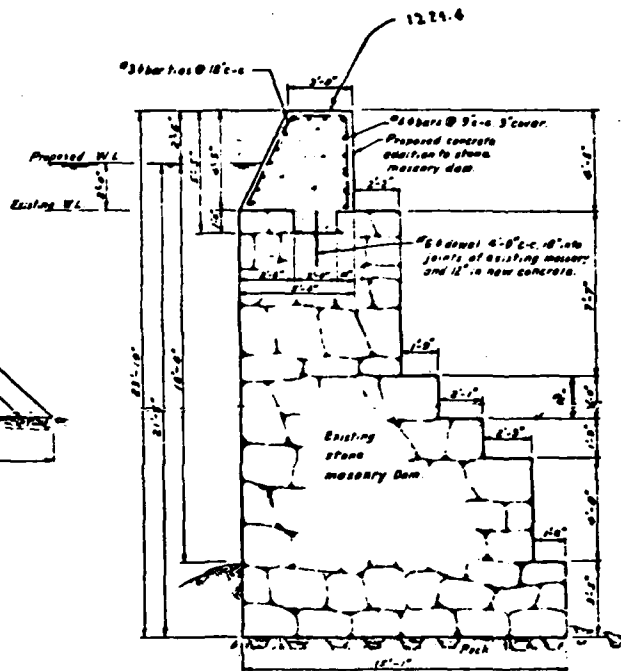
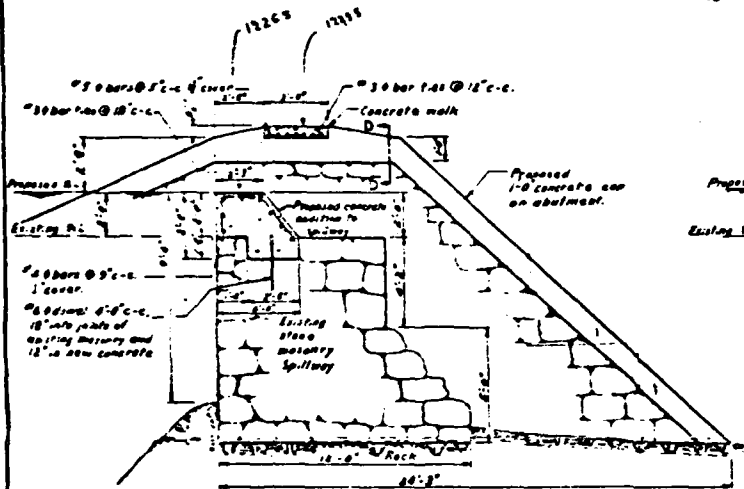
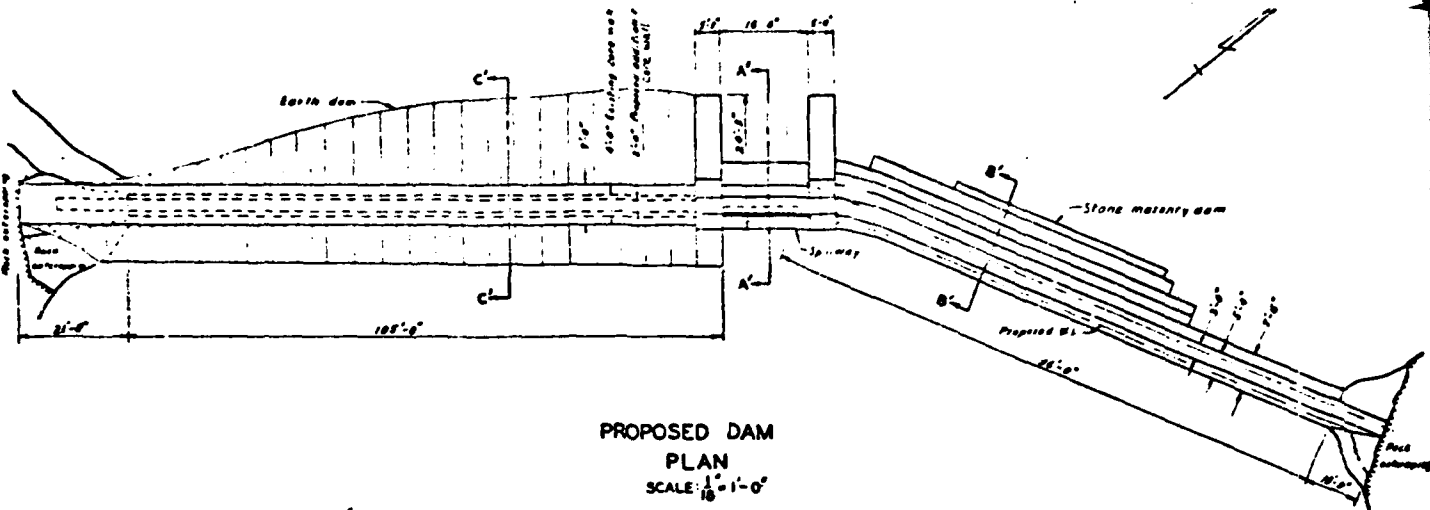

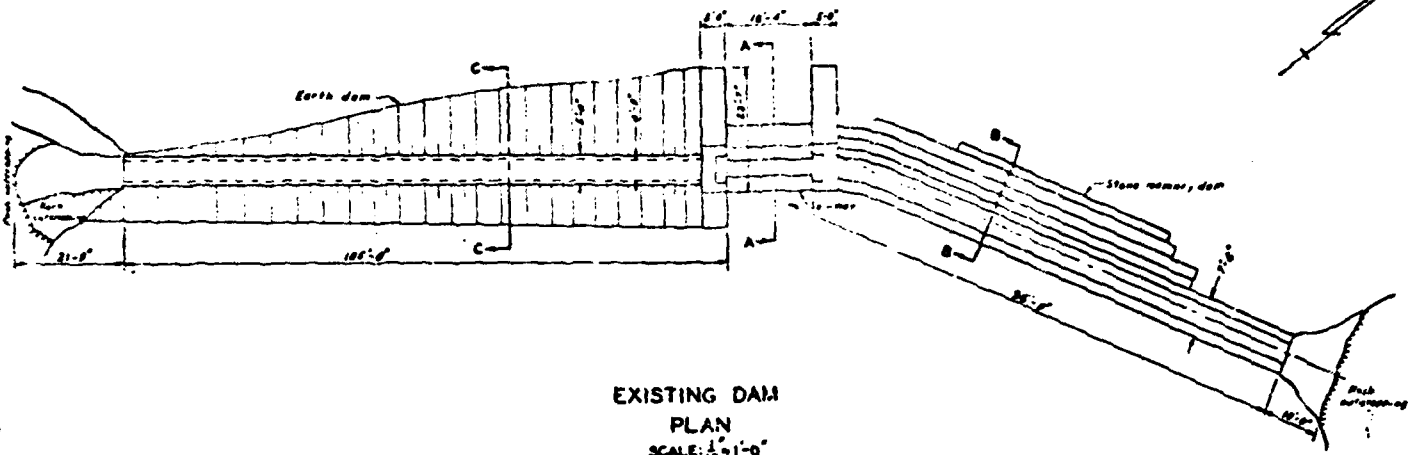

EXISTING DAM
PLAN
SCALE: $\frac{1}{16}'' = 1'-0''$

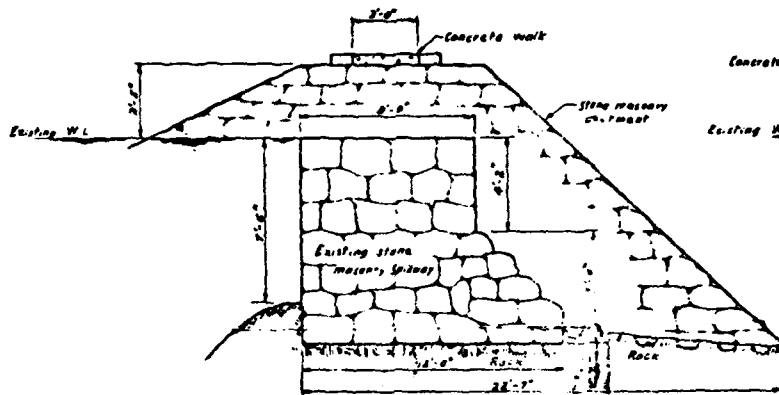

EXISTING SPILLWAY
SECTION A-A
SCALE: $\frac{1}{2}'' = 1'-0''$

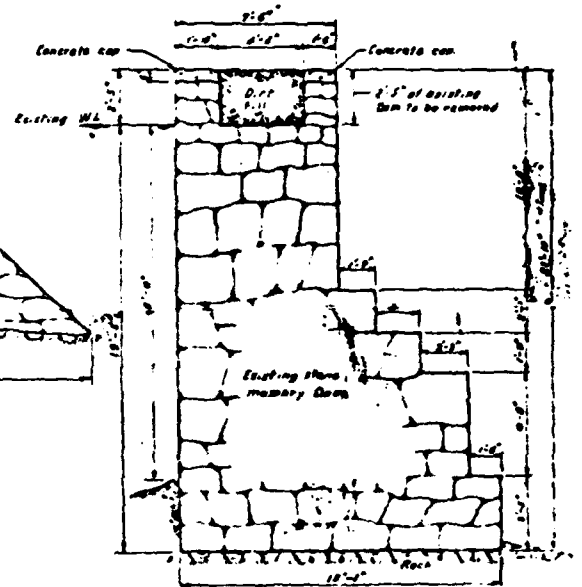

EXISTING DAM
SECTION B-B
SCALE: $\frac{1}{2}'' = 1'-0''$

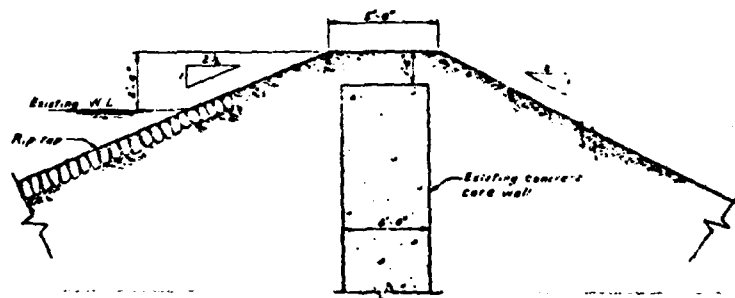

EXISTING DAM
SECTION C-C
SCALE: $\frac{1}{2}'' = 1'-0''$

VILLAGE OF CORNWALL
ORANGE COUNTY, NEW YORK
WATER WORKS IMPROVEMENTS
ARTHURS POND DAM
ALTERATIONS

SCALE: AS SHOWN

JULY 1938

Harold K. ...
DUMMELL ARCHT. & ENG. OFFICE
GLOVERVILLE, NEW YORK
LICENSE NO. N.Y. 22134

PLATE 2

APPENDIX G
BACKGROUND DOCUMENTS

MORRELL VROOMAN ENGINEERS
CONSULTING CIVIL ENGINEERS
GLOVERSVILLE, N. Y.

July 17, 1958

New York State Department of Public Works
State Office Building
Albany, New York

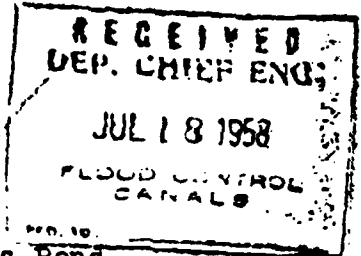

Gentlemen:

Re: Raising of Dam of Arthur's Pond
Reservoir, Water Works Improvements
Village of Cornwall,
Orange County, New York

We are enclosing a print of a plan entitled
"Arthur's Pond Dam Alterations" and dated July 1958
as prepared by us.

The tributary watershed area is 0.22 square miles.
The water surface area of Arthur's Pond is 14 acres
at present spillway level. The watershed is heavily
wooded with a predominance of Evergreen growth and is
a part of experimental forestry planting of Harvard
University. Slopes are moderate.

In our review and planning we have used a figure
of 400 second feet per square mile which we feel is
more than ample in consideration of the foregoing facts.

We are also enclosing a United States Geological
Survey Map on which we have indicated Arthur's Pond and
the location of the dam at Arthur's Pond.

We are also enclosing a copy of the application
which it is proposed to transmit to you for approval.

All of this transmittal is for the purpose of your
immediate and informal review with a request that you
telephone us at Gloversville 5-4818 on Friday, July 18
so that we may have the benefit of your comments and
suggestions.

We are preparing to take to a Village Board
meeting on Monday, July 21, an application to the New
York State Water Power and Control Commission and the
construction plans and specifications for this improve-
ment for review and approval to be followed by advertise-
ment for construction required. Consequently, we wish to
make certain that we have prepared for incorporation in

Callahan

New York State Department
of Public Works

July 17, 1958
Page 2

our application to the Water Power and Control Commission and the contract documents is in accordance with your requirements as can be determined by your quick review of the enclosed. We understand that no commitment on final approval is involved by your review of this submission.

We are looking forward to hearing from you by telephone this Friday.

Very truly yours,

MORRELL VROOMAN ENGINEERS

By 
Morrell Vrooman, Jr.

MVJ:cg
Encs.

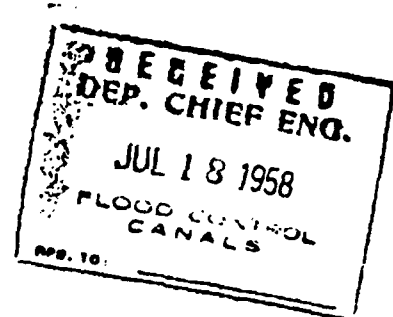

STATE OF NEW YORK

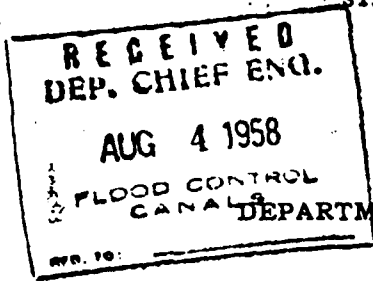

DEPARTMENT OF PUBLIC WORKS

Received Aug 4, 1958 ALBANY Dam No. Orig # 468
 Disposition Approved 6, 1958 195B-2701
 Foundation inspected _____ Watershed LOWER HUDSON RIVER.
 Structure inspected _____

Application for the Construction or Reconstruction of a Dam

Application is hereby made to the Superintendent of Public Works, Albany, N. Y., in compliance with the provisions of Section 948 of the Conservation Law (see third page of this application) for the approval of specifications and detailed drawings, marked Village of Cornwall, Water Works

Improvement, Arthur's Pond Dam Alterations

herewith submitted for the ~~reconstruction~~ reconstruction of a dam herein described. All provisions of law will be complied with in the erection of the proposed dam. It is intended to complete the work covered by the application about December 1, 1958

Idlewild Creek
 1. The dam will be on small stream flowing into to Hudson River in the town of Cornwall County of Orange and three miles from the Village of Cornwall

(Give exact distance and direction from a well-known bridge, dam, village, main cross-roads or mouth of a stream)
 2. Location of dam is shown on the Cornwall quadrangle of the United States Geological Survey.

- The name of the owner is Village of Cornwall
- The address of the owner is Cornwall-on-Hudson, New York
- The dam will be used for Water Supply
- Will any part of the dam be built upon or its pond flood any State lands? No
- (The watershed) above the proposed dam is 0.22 square miles.
- The proposed dam will create a pond area at the spillcrest elevation of 14 acres and will impound 6,711,600 cubic feet of water.

(not printed) Contact the relevant agency for the project

9. The maximum height of the proposed dam above the bed of the stream is 20 feet 6 inches.
10. The lowest part of the natural shore of the pond is mountainous feet vertically above the spillcrest, and everywhere else the shore will be at least 100 feet above the spillcrest.
11. State if any damage to life or to any buildings, roads or other property could be caused by any possible failure of the proposed dam None
12. The natural material of the bed on which the proposed dam will rest is (clay, sand, gravel, boulders, granite, shale, slate, limestone, etc.) Rock
13. Facing downstream, what is the nature of material composing the right bank? Rock
14. Facing downstream, what is the nature of the material composing the left bank? Rock
15. State the character of the bed and the banks in respect to the hardness, perviousness, water bearing, effect of exposure to air and to water, uniformity, etc. Rock
16. Are there any porous seams or fissures beneath the foundation of the proposed dam? None
17. WASTES. The spillway of the above proposed dam will be 16' 4" feet long in the clear; the waters will be held at the right end by a masonry wall the top of which will be 2.5 feet above the spillcrest, and have a top width of 5.0 feet; and at the left end by a masonry wall the top of which will be 2.5 feet above the spillcrest, and have a top width of 5.0 feet.
18. The spillway is designed to safely discharge (88) 195 cubic feet per second.
19. Pipes, sluice gates, etc., for flood discharge will be provided through the dam as follows:
10" C.I. Pipe (existing)
20. What is the maximum height of flash boards which will be used on this dam? None
21. APRON. Below the proposed dam there will be an apron built of Rock (existing) 41 feet long across the stream, 41 feet wide and 1 feet thick.
22. Does this dam constitute any part of a public water supply? Yes
(Application for approval of use of this supply being submitted to the New York State Water Power and Control Commission)

who shall thereupon pay the same into the treasury. Any amount so levied shall thereupon become a lien upon the real property affected thereby, to the same extent as any tax levy becomes and is a lien thereon.

Any person in interest may, within thirty days from the service of any such order, appeal to the supreme court to determine the reasonableness of such order. At any time during such appeal to the supreme court upon at least three days' notice, the party appealing may apply for an order directing any question of fact to be tried and determined by a jury, and the court shall thereupon cause such question to be stated for trial accordingly and the findings of the jury upon such question shall be conclusive. Appeals may be taken from the supreme court to the appellate division of the supreme court and to the court of appeals in such cases, subject to the limitations provided in the civil practice act.

This section shall not apply to a dam where the area draining into the pond formed thereby does not exceed one square mile, unless the dam is more than ten feet in height above the natural bed of the stream at any point or unless the quantity of water which the dam impounds exceeds one million gallons; nor to a dock, pier, wharf or other structure under the jurisdiction of the department of docks, if any, in a city of over one hundred and seventy-five thousand population. This section as hereby amended shall not impair the effect of an order heretofore made by the conservation commission or commissioner under this section prior to the taking effect of chapter four hundred and ninety-nine of the laws of nineteen hundred and twenty-one, nor require the approval by the superintendent of public works, of plans and specifications theretofore approved by such commission or commissioner under this section.

The foregoing information is correct to the best of my knowledge and belief, and the construction will be carried out in accordance with the approved plans and specifications.

Village of Cornwall, New York
....., Owner
By *Michael J. Donahue*
....., authorized agent of owner.
Address of signer..... Cornwall-on-Hudson, New York..... Date July 21, 1958

MORRELL
Morrell Technical Engineers
21 1/2th Ave. S.E.
Gloversville, N. Y.

S P E C I F I C A T I O N S

Scope of Work

CONTRACT NO. 8 - RAISING ARTHURS POND DAM

Construction under this contract shall include the following work:

- 1) All necessary excavation to expose the existing concrete corewall and the removal of the earth fill on the dam section.
- 2) The placing of a 2-foot high by 2-foot wide concrete corewall on the existing corewall. In addition a 3-inch keyway and the necessary dowels shall be provided in the existing corewall.
- 3) Providing a new concrete cap on the abutment walls of the spillway and the tearing down and the replacing of a suspended concrete walkway across the spillway.
- 4) The removal of approximately 2½-feet of stone masonry and the removal of the earth fill on the stone masonry dam section and the providing of a 4-foot 5-inch high concrete dam section.
- 5) The furnishing and placing of embankment on the existing earth dam section after the removal of top soil and vegetation.
- 6) The furnishing and placing of riprap or stone paving on the earth dam section.
- 7) The clearing of the new flooded area around the pond.

This work is more fully defined hereinafter in the specifications for each of the items.

STATE OF NEW YORK
DEPARTMENT OF PUBLIC WORKS
DIVISION OF CONSTRUCTION
ALBANY, N. Y.

This plan for.....*August 6, 1958*.....*orig #268*.....*5*.....*1958-2201*.....
..... watershed is hereby
approved under the provisions of Section 948 of the
Conservation Law.

Examined and recommended to the Chief Engineer for
approval.

J. C. Osborn
ASSOCIATE CIVIL ENGINEER

DAM INSPECTION REPORT
(By Visual Inspection)

<u>Dam Number</u>	<u>River Basin</u>	<u>Town</u>	<u>County</u>	<u>Hazard Class*</u>	<u>Date & Inspector</u>
195B-3629	L Hudson	Cornwall	Orange	A-B Res.	10/11/74 KVA

Type of Construction

- Earth w/concrete spillway
- Earth w/drop inlet pipe
- Earth w/stone or riprap spillway
- Concrete
- Stone
- Timber

Use

- Water Supply
- Power
- Recreation
- Fish and Wildlife
- Farm Pond
- No Apparent Use-Abandoned

Estimated Impoundment Size

- 1-5 acres
- 5-10 acres
- Over 10 acres

Estimated Height of Dam above Streambed

- Under 10 feet
- 10-25 feet
- Over 25 feet

Condition of Spillway

- Service satisfactory
- In need of repair or maintenance
- Auxiliary satisfactory
- In need of repair or maintenance

Explain: _____

Condition of Non-Overflow Section

- Satisfactory
- In need of repair or maintenance

Explain: _____

Small leaks - R. wing wall

Condition of Mechanical Equipment

- Satisfactory
- In need of repair or maintenance

Explain: _____

Evaluation (From Visual Inspection)

- No defects observed beyond normal maintenance
- Repairs required beyond normal maintenance

*Explain Hazard Class, if Necessary _____

DATE
FILMED

— 8