

12

DAVID W. TAYLOR NAVAL SHIP RESEARCH AND DEVELOPMENT CENTER

Bethesda, Maryland 20084



by John F. O'Dea and Y. H. Kim

AD A105971

ADDED RESISTANCE AND POWER OF A FRIGATE
IN REGULAR WAVES

John F. O'Dea and Y. H. Kim

APPROVED FOR PUBLIC RELEASE: DISTRIBUTION UNLIMITED

SHIP PERFORMANCE DEPARTMENT REPORT

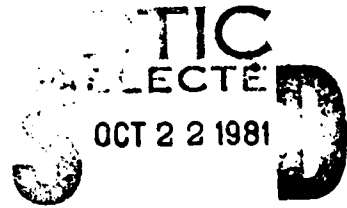

A

SEPTEMBER 1981

DTNSRDC/SPD-0964-02

DTNSRDC FILE COPY

ADDED RESISTANCE AND POWER OF A FRIGATE IN REGULAR WAVES

81 10 21

MAJOR DTNSRDC ORGANIZATIONAL COMPONENTS

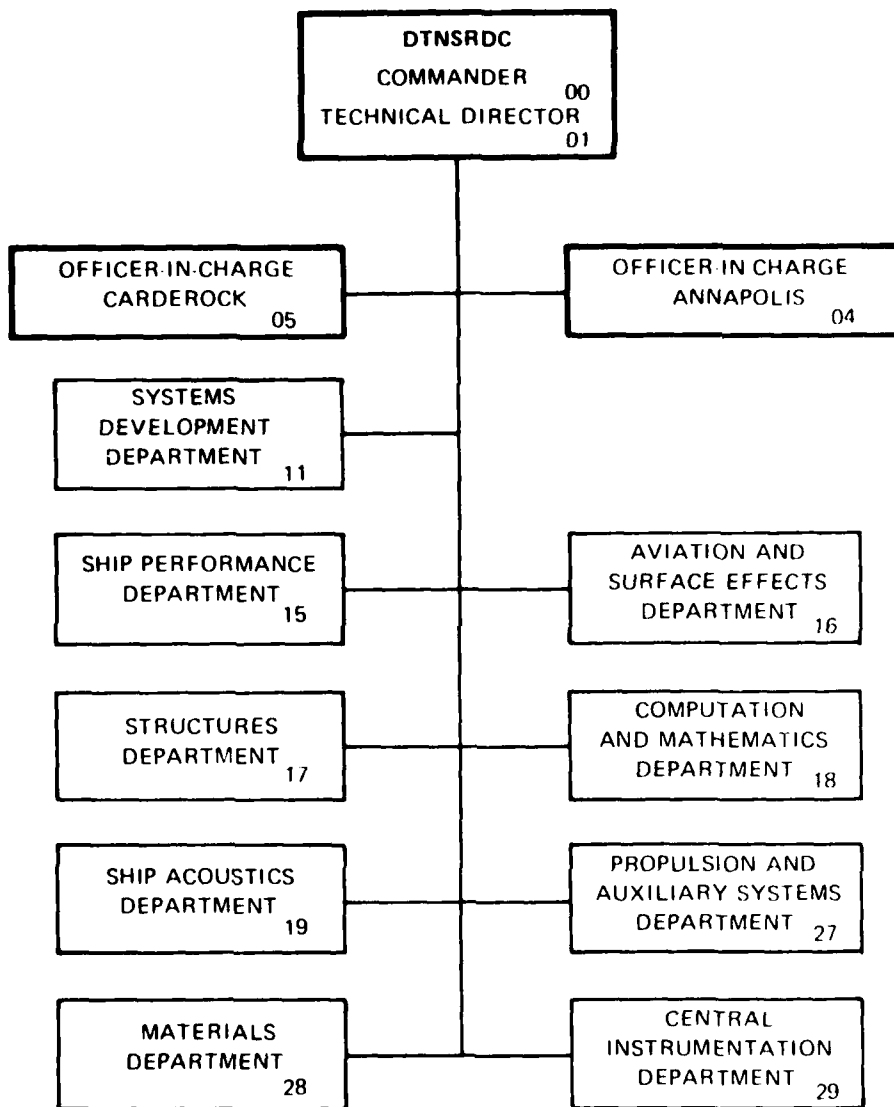

UNCLASSIFIED

SECURITY CLASSIFICATION OF THIS PAGE (When Data Entered)

REPORT DOCUMENTATION PAGE		READ INSTRUCTIONS BEFORE COMPLETING FORM
1. REPORT NUMBER	2. GOVT ACCESSION NO.	3. RECIPIENT'S CATALOG NUMBER
	AD-A205	973
4. TITLE (and Subtitle)	5. TYPE OF REPORT & PERIOD COVERED	
ADDED RESISTANCE AND POWER OF A FRIGATE IN REGULAR WAVES.	9) FINAL rept	
	6. PERFORMING ORG. REPORT NUMBER	
7. AUTHOR(s)	8. CONTRACT OR GRANT NUMBER(s)	
John F./O'Dea and Y. H./Kim		
9. PERFORMING ORGANIZATION NAME AND ADDRESS	10. PROGRAM ELEMENT, PROJECT, TASK AREA & WORK UNIT NUMBERS	
David W. Taylor Naval Ship R&D Center Ship Performance Department Bethesda, Md 20084	Work Unit 1-1500-104 1-1507-101	
11. CONTROLLING OFFICE NAME AND ADDRESS	12. REPORT DATE	13. NUMBER OF PAGES
Naval Material Command Washington, D.C. 20380	11) September, 1981	28+iv
14. MONITORING AGENCY NAME & ADDRESS (if different from Controlling Office)	15. SECURITY CLASS. (of this report)	
14) DTN SRDZ/SPD-0964-02	UNCLASSIFIED	
	15a. DECLASSIFICATION DOWNGRADING SCHEDULE	
16. DISTRIBUTION STATEMENT (of this Report)		
APPROVED FOR PUBLIC RELEASE: DISTRIBUTION UNLIMITED		
17. DISTRIBUTION STATEMENT (of the abstract entered in Block 20, if different from Report)		
18. SUPPLEMENTARY NOTES		
19. KEY WORDS (Continue on reverse side if necessary and identify by block number)		
Ship Resistance Ship Motion Ship Diffraction Waves		
20. ABSTRACT (Continue on reverse side if necessary and identify by block number)		
Added resistance and powering in waves characteristics of the FFG-7 class frigate are presented. Added resistance results for a towed model are presented for two Froude numbers and a range of wavelengths and headings. Experimentally measured added resistance was found to be in reasonable agreement with theoretical predictions in head and bow seas, while measurements at other headings did not show satisfactory correlation. Experiments were also performed with the model powered at the ship self propulsion point for one		

DD FORM 1473

1 JAN 73

EDITION OF 1 NOV 65 IS OBSOLETE

S N 0102- LF-014-6601

UNCLASSIFIED

589694

SECURITY CLASSIFICATION OF THIS PAGE (When Data Entered)

UNCLASSIFIED

SECURITY CLASSIFICATION OF THIS PAGE (When Data Entered)

speed and two headings, and it was found that self propulsion did not have a strong effect on the measured added resistance.

S N 0102- LF- 014- 6601

UNCLASSIFIED

SECURITY CLASSIFICATION OF THIS PAGE(When Data Entered)

TABLE OF CONTENTS

	Page
ABSTRACT	1
ADMINISTRATIVE INFORMATION	1
INTRODUCTION	1
THEORY	2
EXPERIMENTAL PROCEDURE	2
RESULTS	3
DISCUSSION	4
CONCLUSIONS	6
ACKNOWLEDGEMENT	6
REFERENCES	7

RECEIVED DATE: 11/11/51 BY: [unclear]	
DISTRIBUTION	
BY:	
Distribution/	
Availability Codes	
Serial number/	
Dist. Special	
A	

LIST OF FIGURES

	Page
1 - Coordinate System	8
2 - Heave Magnitude (α_3/A) for FFG-7 at $F_n = 0.15$	9
3 - Pitch Magnitude ($\alpha_5 L/2A$) for FFG-7 at $F_n = 0.15$	10
4 - Heave Magnitude (α_3/A) for FFG-7 at $F_n = 0.30$	11
5 - Pitch Magnitude ($\alpha_5 L/2A$) for FFG-7 at $F_n = 0.30$	12
6 - Added Resistance Coefficient for Froude No. = 0.15, Wave Heading = 180°	13
7 - Added Resistance Coefficient for Froude No. = 0.15, Wave Heading = 165°	14
8 - Added Resistance Coefficient for Froude No. = 0.15, Wave Heading = 150°	15
9 - Added Resistance Coefficient for Froude No. = 0.15, Wave Heading = 135°	16
10- Added Resistance Coefficient for Froude No. = 0.15, Wave Heading = 120°	17
11- Added Resistance Coefficient for Froude No. = 0.15, Wave Heading = 090°	18
12- Added Resistance Coefficient for Froude No. = 0.15, Wave Heading = 045°	19
13- Added Resistance Coefficient for Froude No. = 0.15, Wave Heading = 000°	20
14- Added Resistance Coefficient for Froude No. = 0.30, Wave Heading = 180°	21
15- Added Resistance Coefficient for Froude No. = 0.30, Wave Heading = 165°	22
16- Added Resistance Coefficient for Froude No. = 0.30, Wave Heading = 150°	23
17- Added Resistance Coefficient for Froude No. = 0.30, Wave Heading = 135°	24
18- Added Resistance Coefficient for Froude No. = 0.30, Wave Heading = 120°	25
19- Added Resistance Coefficient for Froude No. = 0.30, Wave Heading = 090°	26
20- Added Resistance Coefficient for Froude No. = 0.30, Wave Heading = 045°	27
21- Added Resistance Coefficient for Froude No. = 0.30, Wave Heading = 000°	28

NOTATION

A	wave amplitude
B	ship beam
g	gravitational constant
$H(u, \lambda)$	Kochin function
R_{AW}	added resistance due to waves
L	ship length
U	ship speed
α_1	surge
α_2	sway
α_3	heave
α_4	roll
α_5	pitch
α_6	yaw
β	wave-to-ship heading (180° head seas)
λ	wavelength
ρ	mass density of water
σ_{AW}	added resistance coefficient, $\sigma_{AW} = \frac{R_{AW}}{\rho g A^2 (B^2/L)}$

ABSTRACT

Added resistance and powering in waves characteristics of the FFG-7 class frigate are presented. Added resistance results for a towed model are presented for two Froude numbers and a range of wavelengths and headings. Experimentally measured added resistance was found to be in reasonable agreement with theoretical predictions in head and bow seas, while measurements at other headings did not show satisfactory correlation. Experiments were also performed with the model powered at the ship self propulsion point for one speed and two headings, and it was found that self propulsion did not have a strong effect on the measured added resistance.

ADMINISTRATIVE INFORMATION

This work was sponsored by the Naval Material Command (NAVMAT) Ship Performance and Hydromechanic Program, under work units 1-1500-104 and 1-1507-101.

INTRODUCTION

Hydrodynamic optimization of a ship hull form usually concentrates on the calm water resistance and propulsion performance. However, the ship will actually operate in an environment of ocean waves. The action of the waves will tend to increase the power required to maintain speed or, alternatively, cause a speed reduction relative to the speed obtainable at the same power level in calm water. The increase in power or reduction in speed will depend on the hydrodynamic characteristics of the hull and propeller, as well as characteristics of the sea state such as spectral density and wave-to-ship relative heading. This factor is usually accounted for in a ship design by including a margin in sizing the propulsion machinery, but it would be desirable to have a more precise means of quantifying the power required for a ship in an actual ocean environment.

Several theoretical approaches to computing added resistance exist. All involve various approaches to estimating the mean force due to interaction of a ship with a wave system, and this force is presumed to vary quadratically with wave amplitude. One such theoretical method is that developed by Lin and Reed¹ at DTNSRDC, and the purpose of this report is to present experimental data for correlation to this theory.

In addition to the resistance change in waves, the propulsive efficiency may be altered due to wave action. Much less attention has been paid to this aspect of powering in waves, as a recent review by Faltinsen et al.² indicates. Therefore, another objective of this experimental program was to obtain data on the components of propulsive efficiency in waves.

¹References are listed on page 7.

THEORY

The problem to be considered here is that of a ship moving at constant forward speed U with arbitrary heading in a plane of progressive waves, as illustrated in Figure 1. Main assumptions and restrictions in the theory are listed below:

- (1) The usual ideal-fluid assumption is made, permitting the use of potential-flow theory;
- (2) The ship has small displacement from the equilibrium position and both the incoming waves and those created by the ship are small;
- (3) The ship is sufficiently "slender" so that each section can be treated as a two-dimensional "strip" with no interaction between them;
- (4) The response of the ship to the incident wave is linear.

Within this framework of assumptions, it can be shown that the solution of the linearized ship motion-potential flow problem is sufficient to calculate the mean added resistance, which is quadratic in wave amplitude.

In 1976 Lin and Reed¹ presented a new approach for evaluating the second-order steady forces in oblique waves. The forces are derived from linear momentum consideration. The second-order steady forces are obtained in terms of the Kochin function $H(u, \lambda)$ by taking a time-average of the periodic forces and invoking the method of stationary phase evaluation of the potentials at a large distance from the ship. A more detailed derivation, together with computational methods, is documented by Kim³.

This theory has been applied to calculate the mean added resistance for a model of the FFG-7 class frigate. Computations were made for two Froude numbers ($F_n = 0.15, 0.30$), eight headings ($180^\circ, 165^\circ, 150^\circ, 135^\circ, 120^\circ, 90^\circ, 45^\circ, 0^\circ$) and nine values of wavelength-to-shiplength ratio between $\lambda/L = 0.25$ and 2.50 . Because the model was to be attached to the towing carriage in such a way that surge, sway and yaw would be restrained, the predictions were made with these modes restrained. The predictions were first made with the ship motions calculated by the Salvesen-Tuck-Faltinsen⁴ ship motion theory. However, for reasons given below, predictions were also made using the experimentally measured values of pitch motion.

EXPERIMENTAL PROCEDURE

The experiments were conducted with a model of the FFG-7 class frigate (Model 5279-1), built to a linear scale ratio of 20.815. In order to measure drag, the

model was attached to the towing carriage through a bracket which restrained the model from surging, swaying or yawing, while permitting freedom in heave, roll and pitch. Drag force was measured by a load cell attached between the roll-pitch gimbal and the towing bracket, and the propeller shaft was instrumented to measure thrust, torque and rpm. Wave elevation was measured with an ultrasonic probe mounted on the centerline in front of the bow. A dummy propeller hub was fitted during the resistance experiments. All experiments were conducted in the Harold E. Saunders Maneuvering and Seakeeping Basin. In this basin, the towing carriage was under a moveable bridge spanning the basin. Wavemakers are arranged along two adjacent sides. By selecting the proper wavemaker bank and bridge position, models may be run at any desired heading relative to wave heading.

Since added resistance is the difference between mean total drag in waves and the calm water drag, frequent runs were made in calm water to monitor this drag component. When runs were made in waves, the data was analyzed over a time interval corresponding to an integer number of wave encounter cycles. This was necessary because the linear oscillatory part of the axial force (that is the surge exciting force) is much larger in amplitude than the mean added resistance. Therefore, taking an average of the drag signal over a fraction of a cycle of the oscillation would seriously bias the estimate of the mean value.

All resistance experiments were carried out over the complete range of Froude numbers, headings and wavelengths listed in the Theory section above. Waves were generated with a nominal height-to-length ratio of $2A/\lambda = 0.01$. A number of runs were selected with different wave amplitudes to determine if the mean added resistance did in fact vary with the square of wave amplitude. When the resistance experiments were completed, a limited set of runs was made with the model propeller running at an RPM corresponding to the ship self-propulsion point in calm water. These runs were made only at a Froude number of 0.30, at headings of 180° and 135° relative to the waves.

RESULTS

Pitch and heave motions, although not the main objective of this work, have a significant effect on added resistance. The measured heave and pitch motions are compared to strip theory computations in Figures 2-5. It can be seen that the agreement between theory and experiment is quite good for heave, but that experimentally measured pitch is higher than predicted, especially for longer

wavelengths. A comparison of roll results has not been presented, because it is known that roll at resonance cannot be predicted well without empirical expressions for viscous roll damping. Furthermore, roll motion is expected to have a minor effect on added resistance, compared to the effects of pitch and heave.

Added resistance results, plotted as the nondimensional operator,

$$\sigma_{AW} = \frac{R_{AW}}{\rho g A^2 (B^2/L)}$$

are presented in Figures 6-21. Also shown on these Figures are predictions from the Lin-Reed theory, in two versions. The first, shown as a solid line, is based on strip theory predictions of pitch and heave motions. The second, shown as a dashed line, is based on the experimentally measured motions. Predictions are not shown for the following seas headings ($\beta = 0^\circ, 45^\circ$) since the experiments generally showed a small positive added resistance, while the predictions were large negative values (indicating a thrust, or resistance reduction due to waves).

Although the agreement between predictions and measurements in following seas was poor, the agreement in head and bow seas was generally more reasonable. One noticeable trend was that the measured values tended to be larger than the predicted values at wavelengths longer than the ship length. This is partly accounted for by basing the added resistance calculations on the actual measured motions.

Added resistance values are also shown in Figures 14 and 17, for the model in the self propelled condition. Because of electronic drift in the transmission dynamometer, no valid data on thrust and torque variation in waves was available. In Figure 14 the added resistance of the propelled model shows slightly greater value than that of a towed model for $\lambda/L \geq 1.0$, but considering the fact that added resistance is a small quantity which is difficult to measure accurately, the increase in resistance, when running the propeller at the constant RPM, seems rather consistent with the corresponding data not propelled. This may imply that little change in mean thrust occurred in waves, but based on the presently available data from this experiment, no conclusions can be drawn concerning the propulsive efficiency in waves.

DISCUSSION

Obtaining accurate experimental data on added resistance is difficult because of the small drag increments to be measured, and because the desired quantity (in its various components) depends on the square of the wave amplitude and motion amplitudes. Therefore, very accurate measurements of drag (both in calm water and in waves),

motions and waves are needed. One problem is accurate resolution of these quantities, particularly for the short wave length region ($\lambda/L < 1$), where wave amplitudes are necessarily small, as is the change in resistance. The problem is compounded by changes in the calm water resistance, which may be caused by roughening of the model surface or a buildup of slime. For these reasons, there can be no great confidence in the experimental results for $\lambda/L < 1.0$. This particularly affects the comparison to predictions for Froude number = 0.15, since at this speed the peak of the predicted added resistance operator curve falls near $\lambda/L = 0.5$.

For the higher Froude number ($F_n = 0.30$), it appears that it is possible to predict the nondimensional added resistance operator with reasonable accuracy in head seas. It is interesting to note that the largest peak in the added resistance operator curves may be at a bow seas heading of perhaps 135° , rather than in direct head seas ($\beta = 180^\circ$), and the operator curves retain significant magnitude out to a heading of $\beta = 120^\circ$. This result may have important implications in the prediction of added resistance and power in short crested seas with wide directional spreading functions.

There is a tendency for the experimental results to be somewhat larger than predicted, for long waves in head seas. This is partly a result of the discrepancy between measured and predicted pitch **magnitude**, which points out the need for accurate predictions of the rigid body motions if added resistance predictions are to be accurate. Since added resistance is a quadratic phenomenon, a small change in the magnitude of a motion, say 10%, may cause a 20% change in the component of added resistance associated with that mode. Phase errors may also be important, although they have not been investigated in this report. In any case, it is quite possible that errors in strip theory, which may be quite acceptable if motion predictions are the goal, may be less acceptable if accurate prediction of added resistance is the goal.

In following seas, the correlation between theory and experiment is poor. The experimental data indicate zero or small positive values of added resistance, while the predictions indicate negative values of resistance, or positive thrust. It is reasonable to expect negative values at zero forward speed, at least for a ship with fore-and-aft symmetry. However, it appears that for the Froude numbers used in these experiments the forward speed effect causes the measured added resistance to be positive in all cases. The discrepancy between theory and experiment should be

investigated further, although added resistance in following seas may be of limited practical interest.

Because of the problems with the instrumentation for measuring thrust and torque, no reliable data was obtained from which information on propulsive efficiency in waves could be derived. Since the measured resistance was comparable to the values for the towed model condition, it is likely that the thrust was not greatly changed by wave action. However, this needs to be confirmed by more experimental data. The effect of waves on the torque also needs to be determined, and a theoretical method should be developed to predict such effects. The importance of these propulsion quantities should be emphasized. Although the bulk of this report deals with added resistance, and the measurement of propulsive quantities in this experiment was unsuccessful, it should be remembered that it is as important to be able to predict propulsive efficiency as it is to predict resistance, since shaft horsepower prediction is the ultimate requirement.

CONCLUSIONS

1. Experimentally measured values of added resistance agree reasonably well with predictions from the Lin-Reed theory in head and bow seas. Added resistance can be quite large in bow seas out to headings of 120° (60° off head seas). However, the correlation between theory and experiment is not good for following seas.
2. Measured added resistance in bow seas and long wave lengths ($\lambda/L > 1.0$) was somewhat larger than predicted. This appears to be caused, at least in part, by the fact that measured pitch motions were larger than predicted by strip theory.
3. Added resistance measured on a self-propelled model was similar to that for the towed-model condition. However, it was not possible to acquire accurate experimental results for thrust and torque in waves. Since propulsive efficiency, along with total resistance, determines the shaft horsepower required to propel a ship in waves, further experiments are recommended to determine the variation of thrust and torque in waves.

ACKNOWLEDGEMENT

The authors wish to acknowledge Douglas Jenkins and Harry Jones for their valuable assistance in carrying out the experimental program.

REFERENCES

1. Lin, W.C. and A.M. Reed, "The Second Order Steady Force and Moment on a Ship Moving in an Oblique Seaway", Eleventh Symposium on Naval Hydrodynamics, London, 1976.
2. Faltinsen, O.M., K.J. Minsaas, N. Liapis and S.O. Skjördal, "Prediction of Resistance and Propulsion of a Ship in a Seaway", Thirteenth Symposium on Naval Hydrodynamics, Tokyo, 1980.
3. Kim, Y.H., "Computation of the Second-Order Steady Forces Acting on a Surface Ship in an Oblique Wave", DTNSRDC/SPD-0964-01, March 1981.
4. Salvesen, N., E.O. Tuck, and O. Faltinsen, "Ship Motions and Sea Loads", Transactions SNAME, Volume 78, 1970.

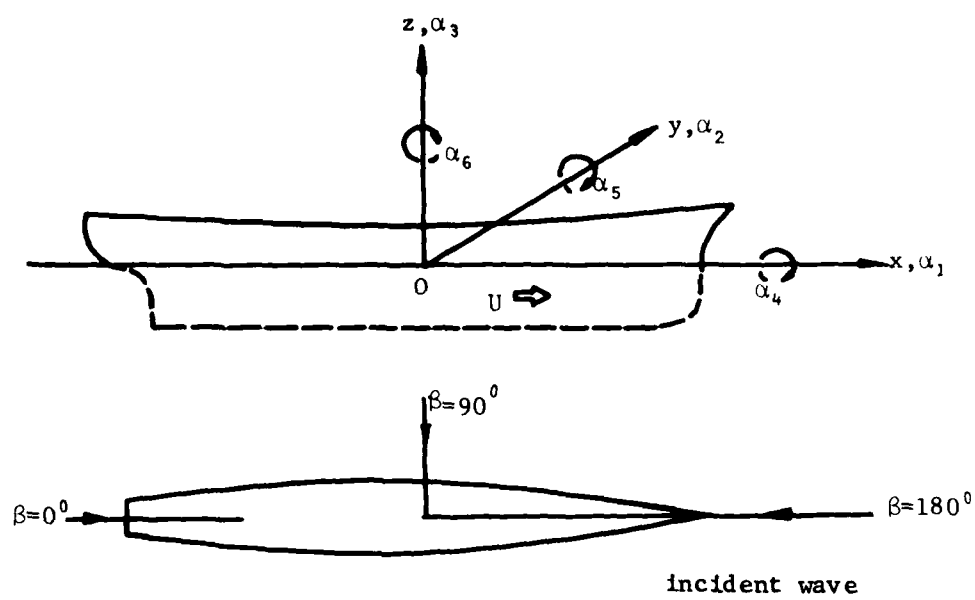

α_1 = surge α_2 = sway α_3 = heave
 α_4 = roll α_5 = pitch α_6 = yaw
 $\beta = 180^\circ$ head seas
 90° beam seas
 0° following seas

Figure 1 - Coordinate System

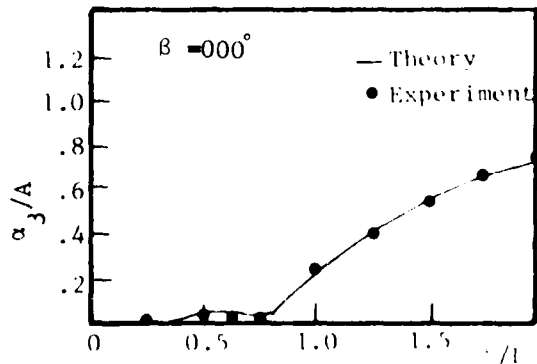
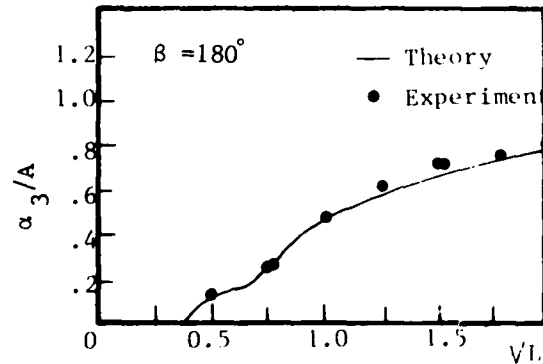
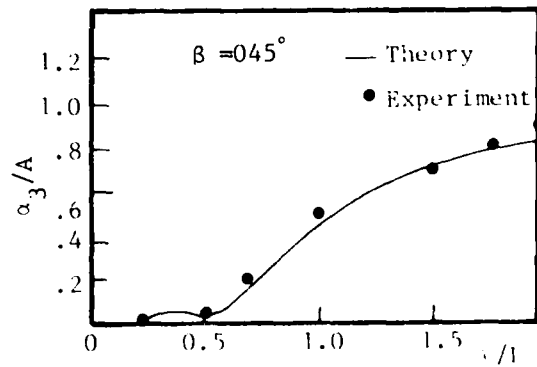
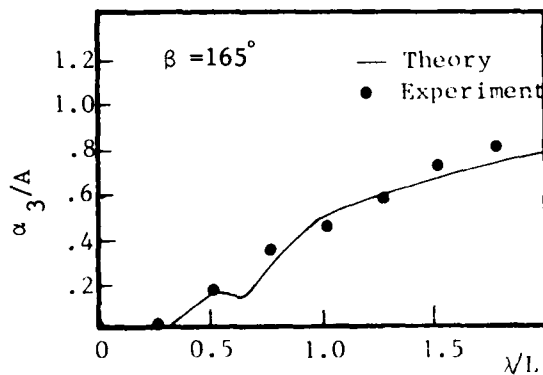
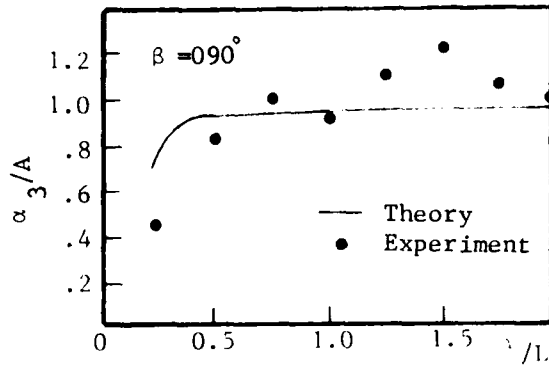
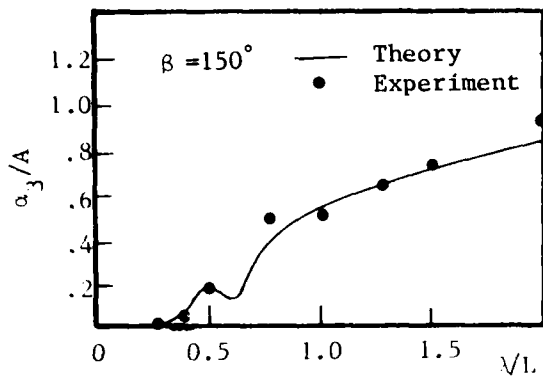
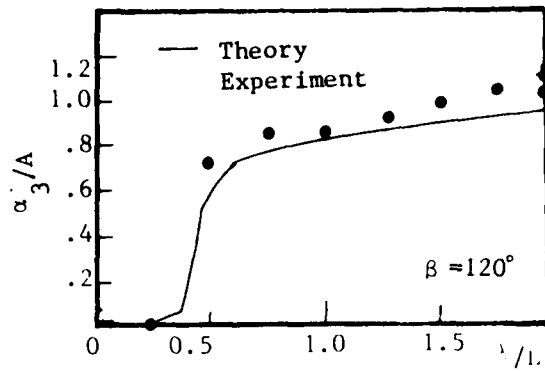
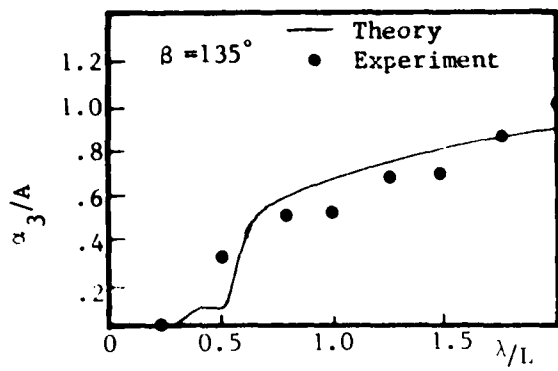

Figure 2 - Heave Magnitude (α_3/A) for FFG-7 at $F_n=0.15$

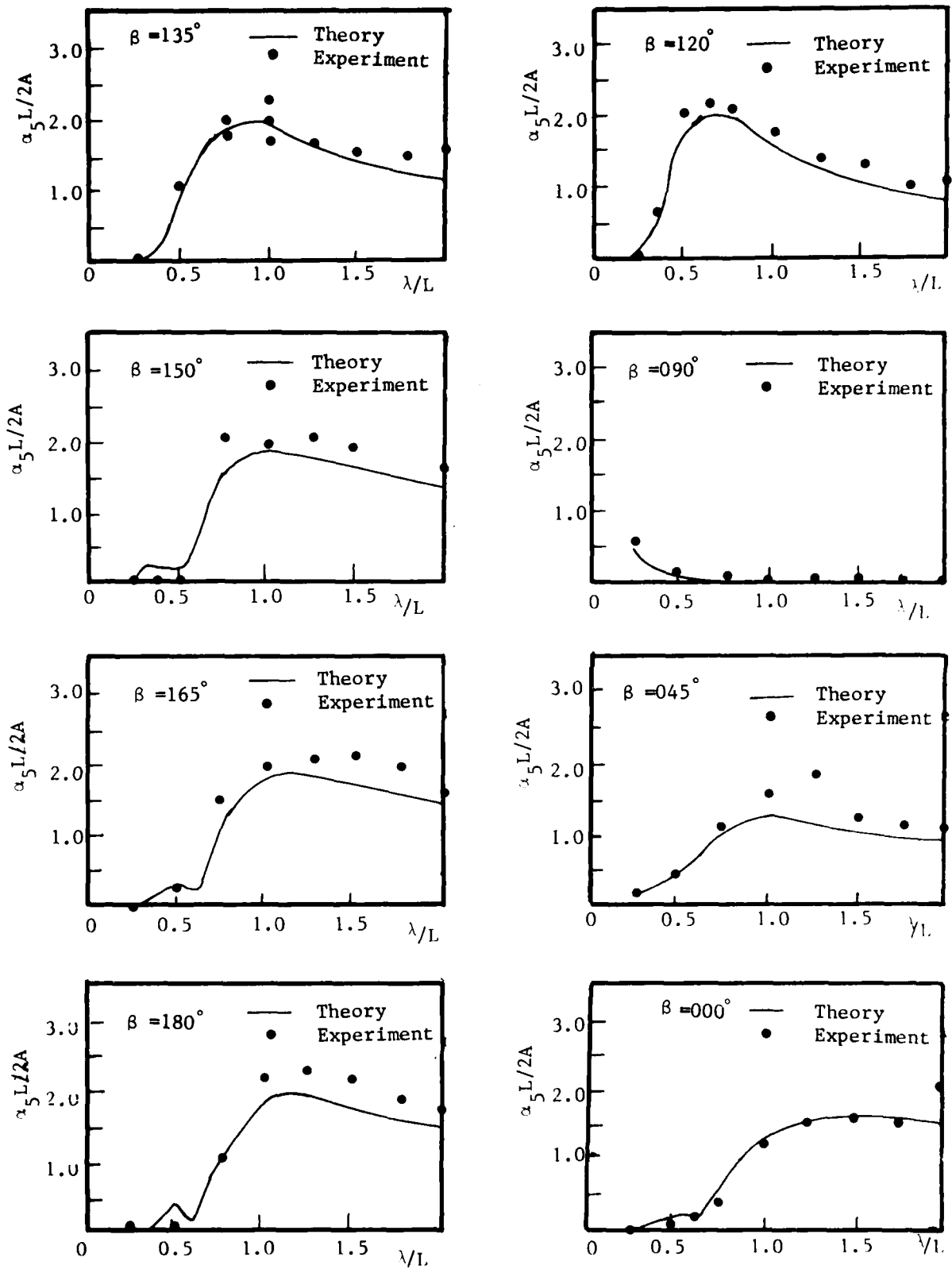

Figure 3 - Pitch Magnitude ($\alpha_5 L/2A$) for FFG-7 at $F_n=0.15$

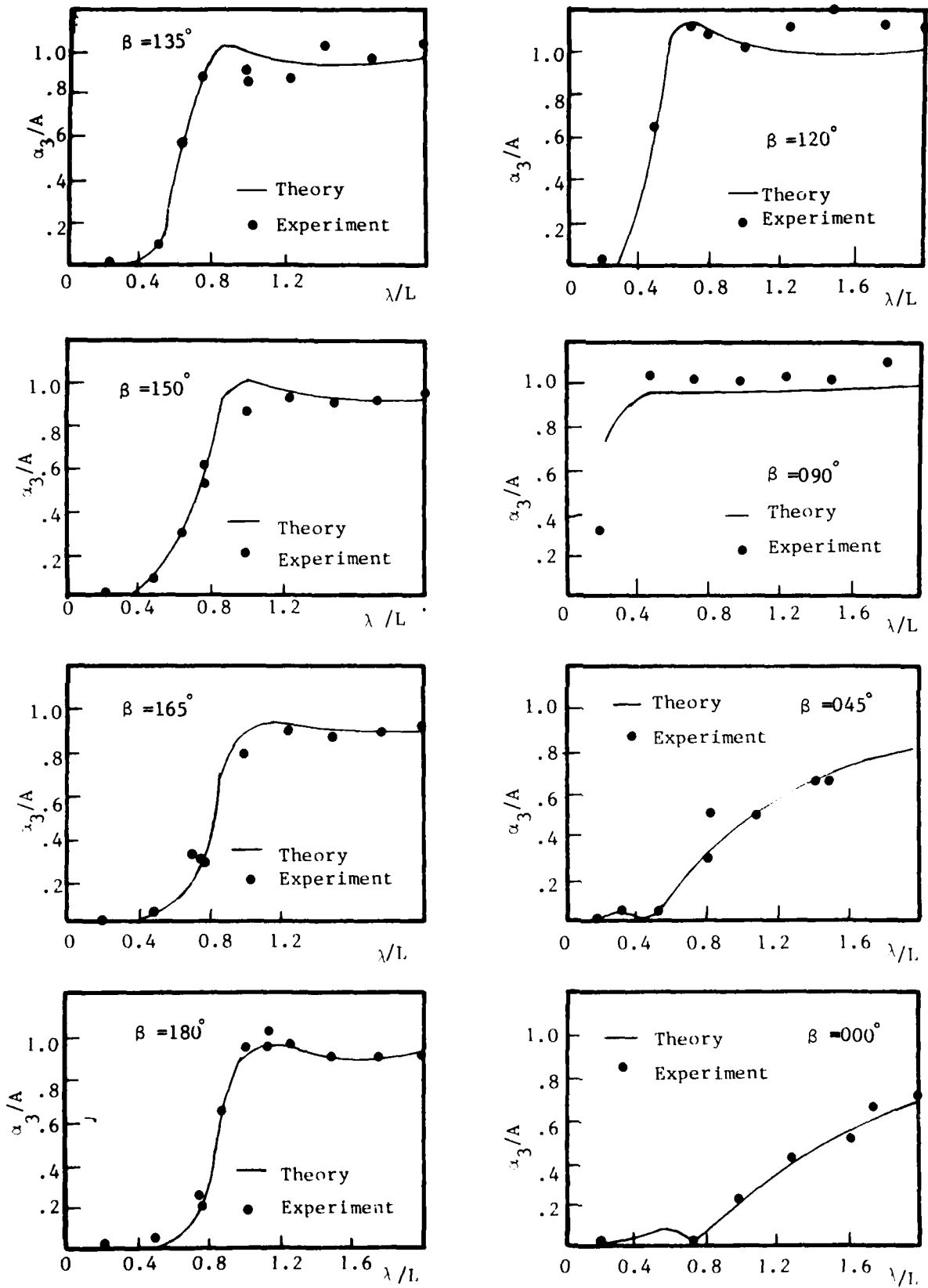

Figure 4 - Heave Magnitude (α_3/A) for FFG-7 at $F_n = 0.30$

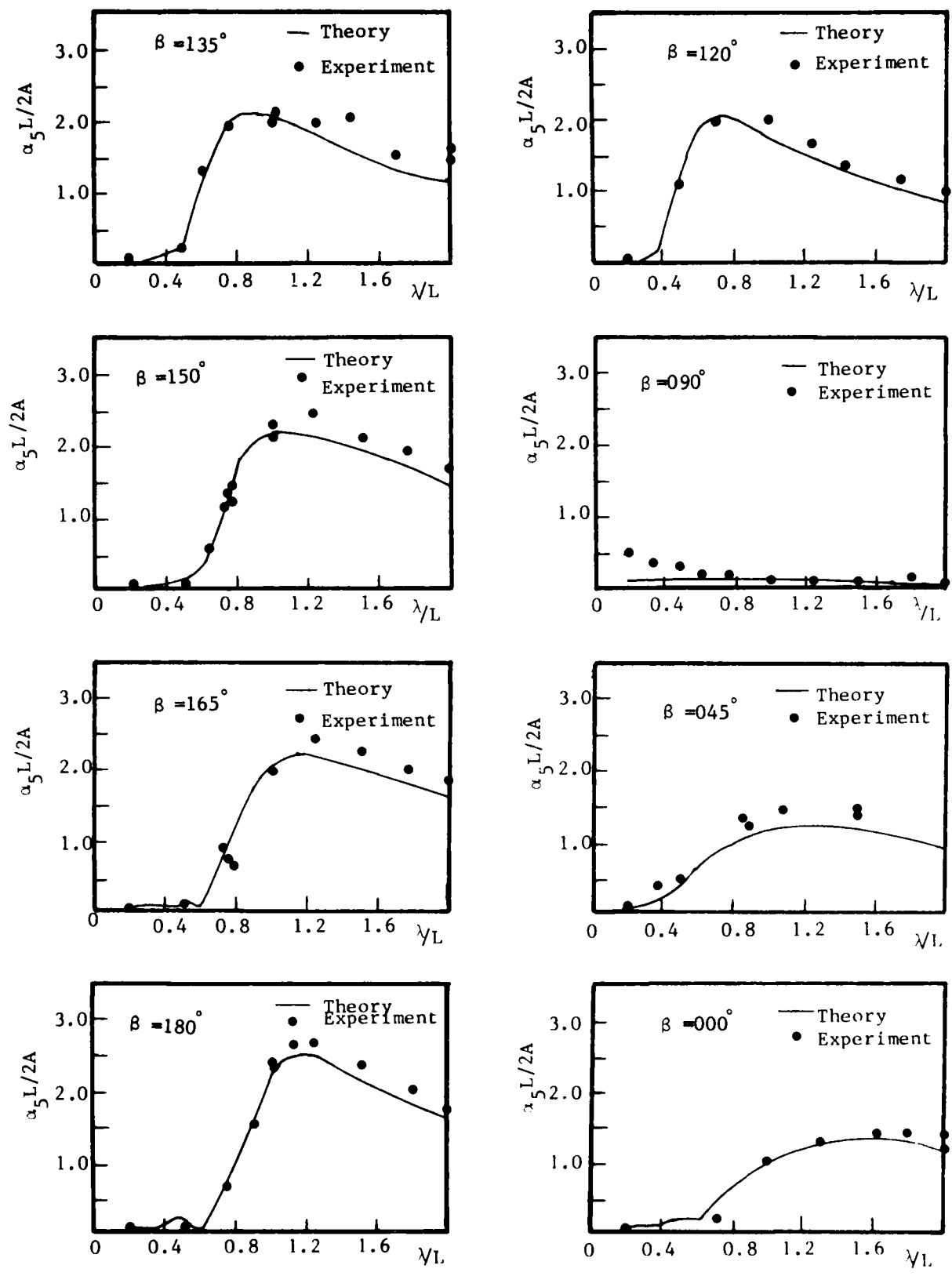

Figure 5 - Pitch Magnitude ($\alpha_5 L / 2A$) for FFG-7 at $F_n = 0.30$

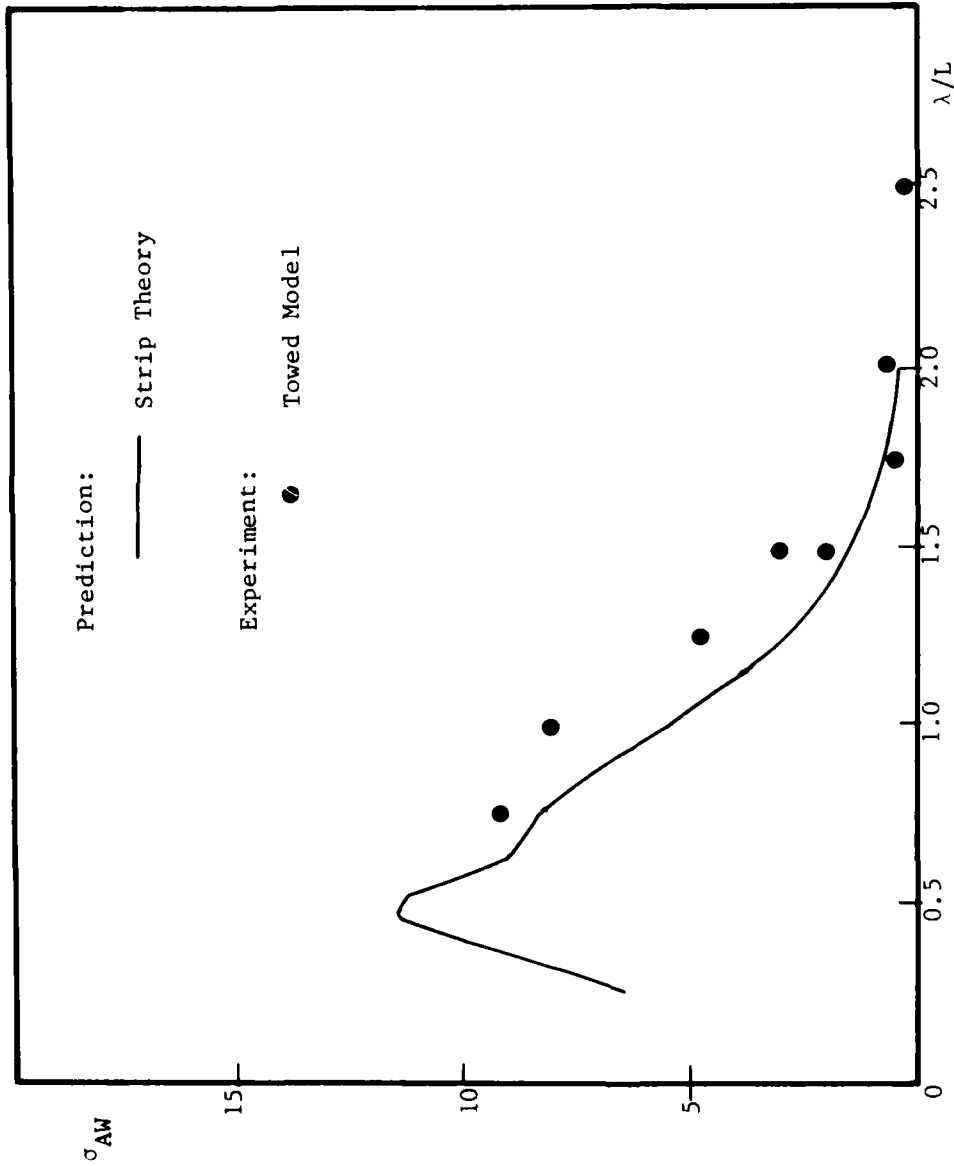

Figure 6 - Added Resistance Coefficient for Froude No.=0.15, Wave Heading=180°

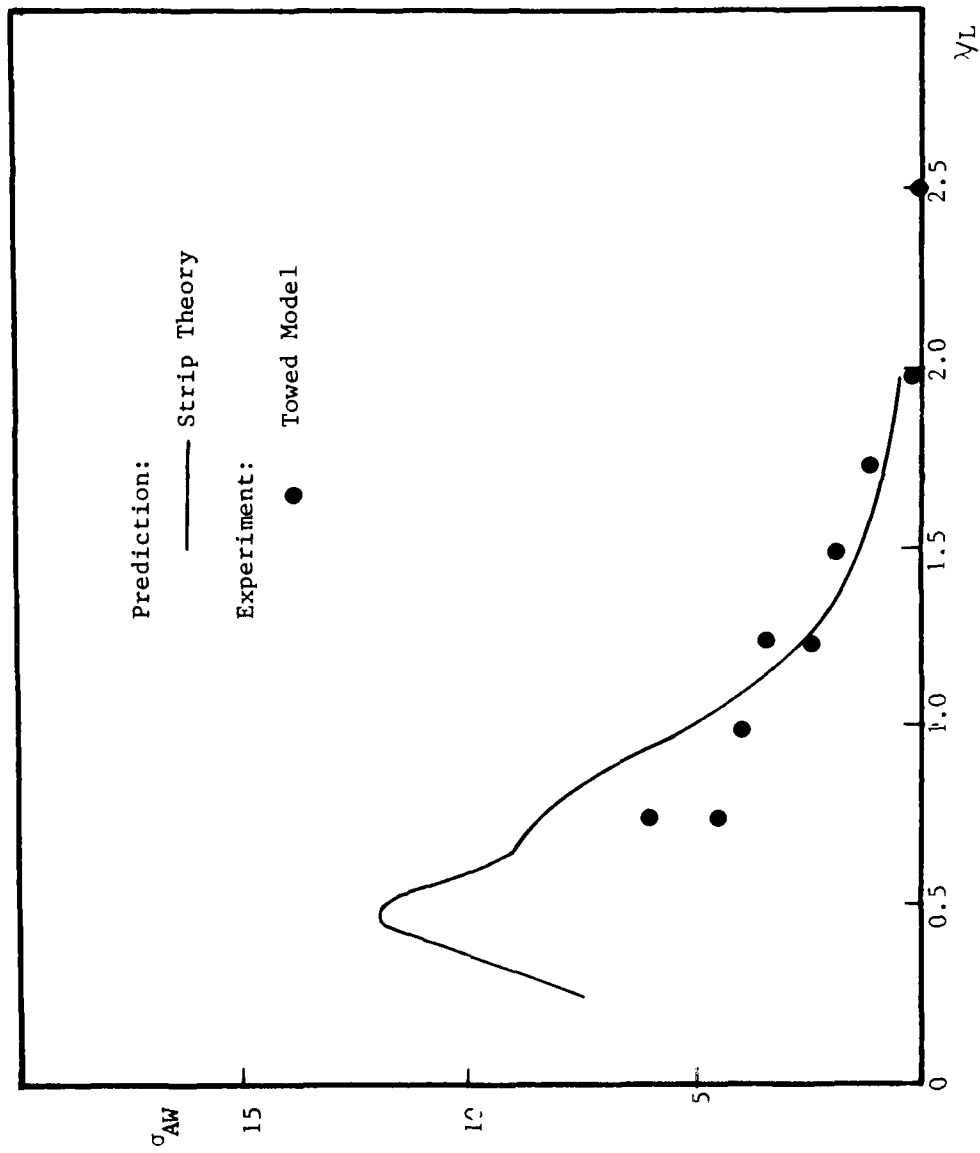

Figure 7 - Added Resistance Coefficient for Froude No.=0.15, Wave Heading=165°

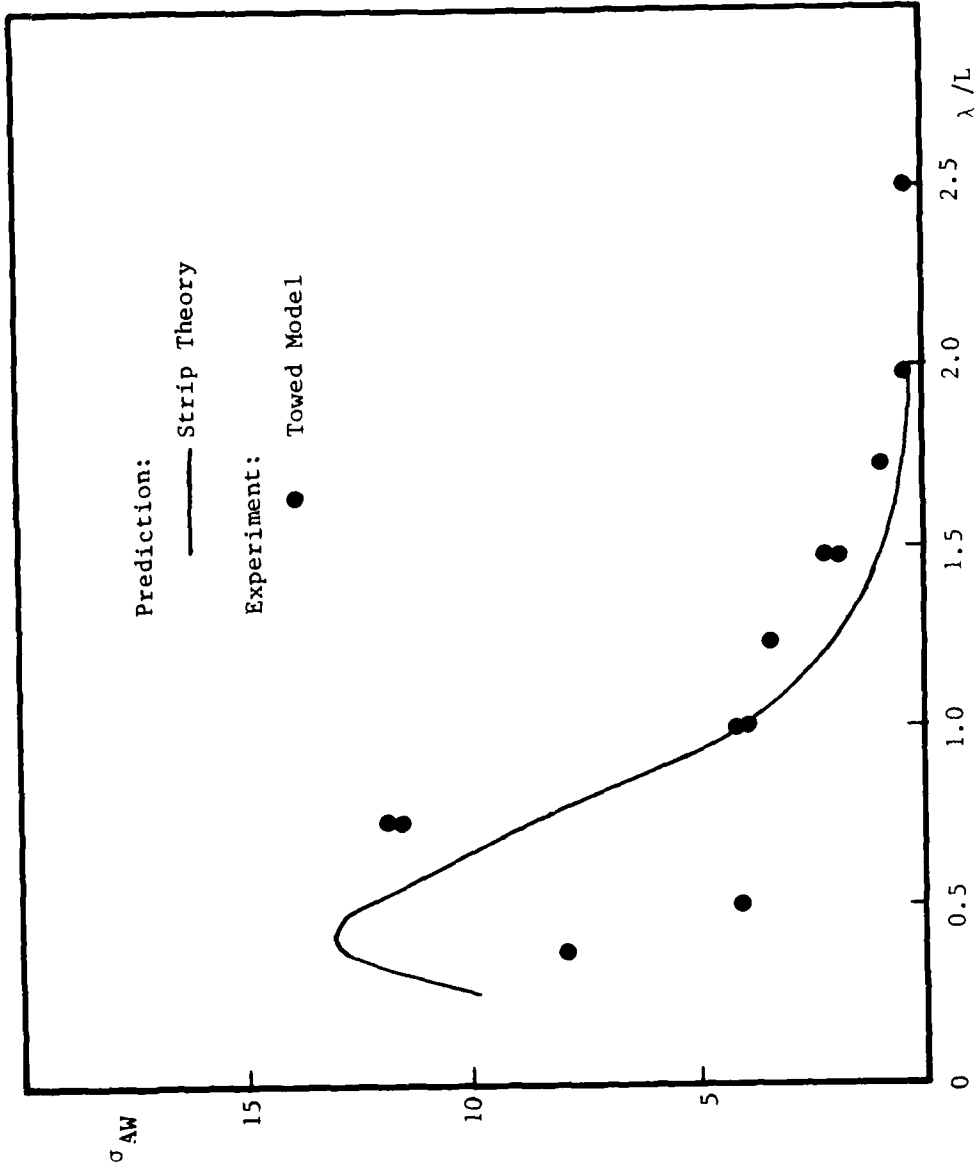

Figure 8 - Added Resistance Coefficient for Froude No.=0.15, Wave Heading=150°

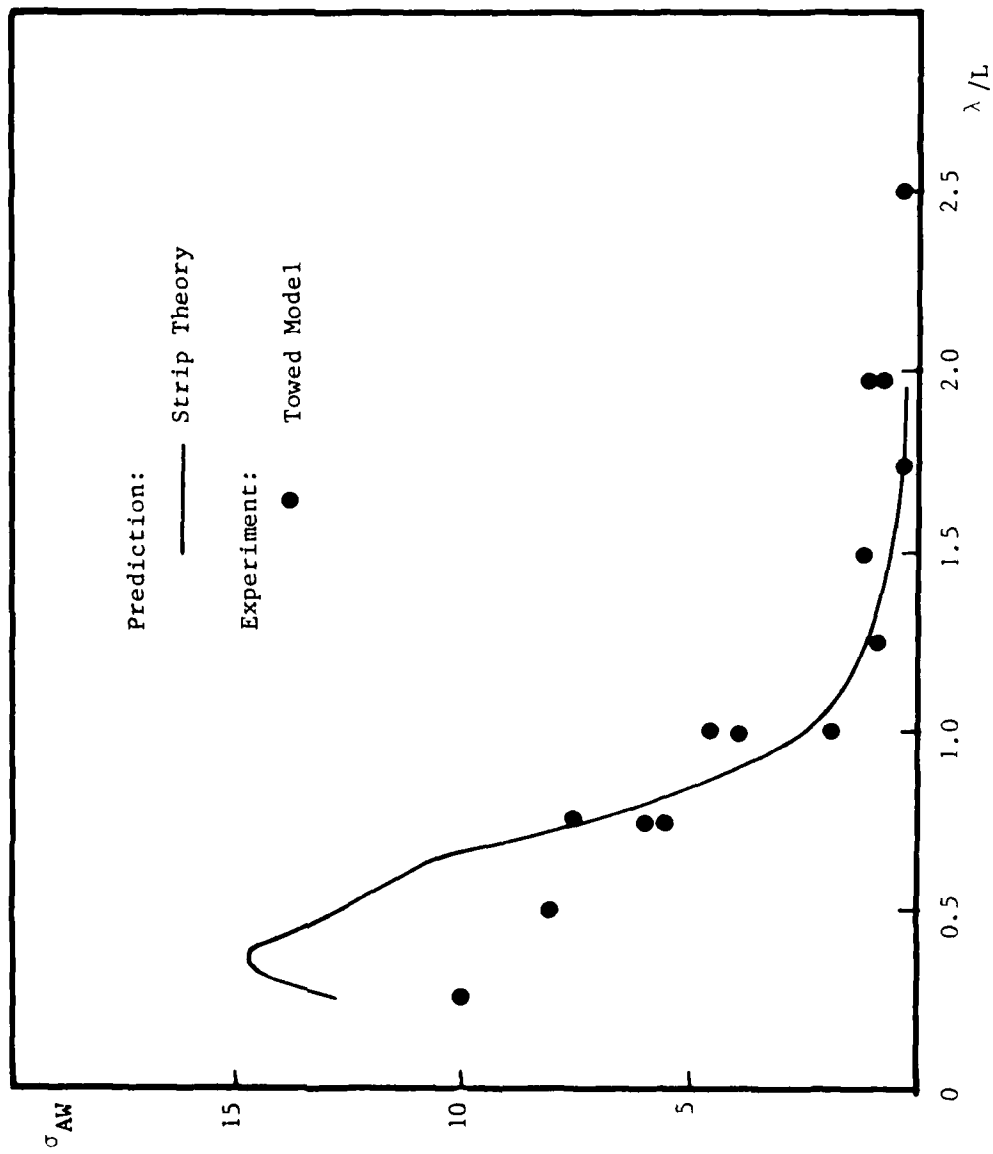

Figure 9 - Added Resistance Coefficient for Froude No.=0.15, Wave Heading=135°

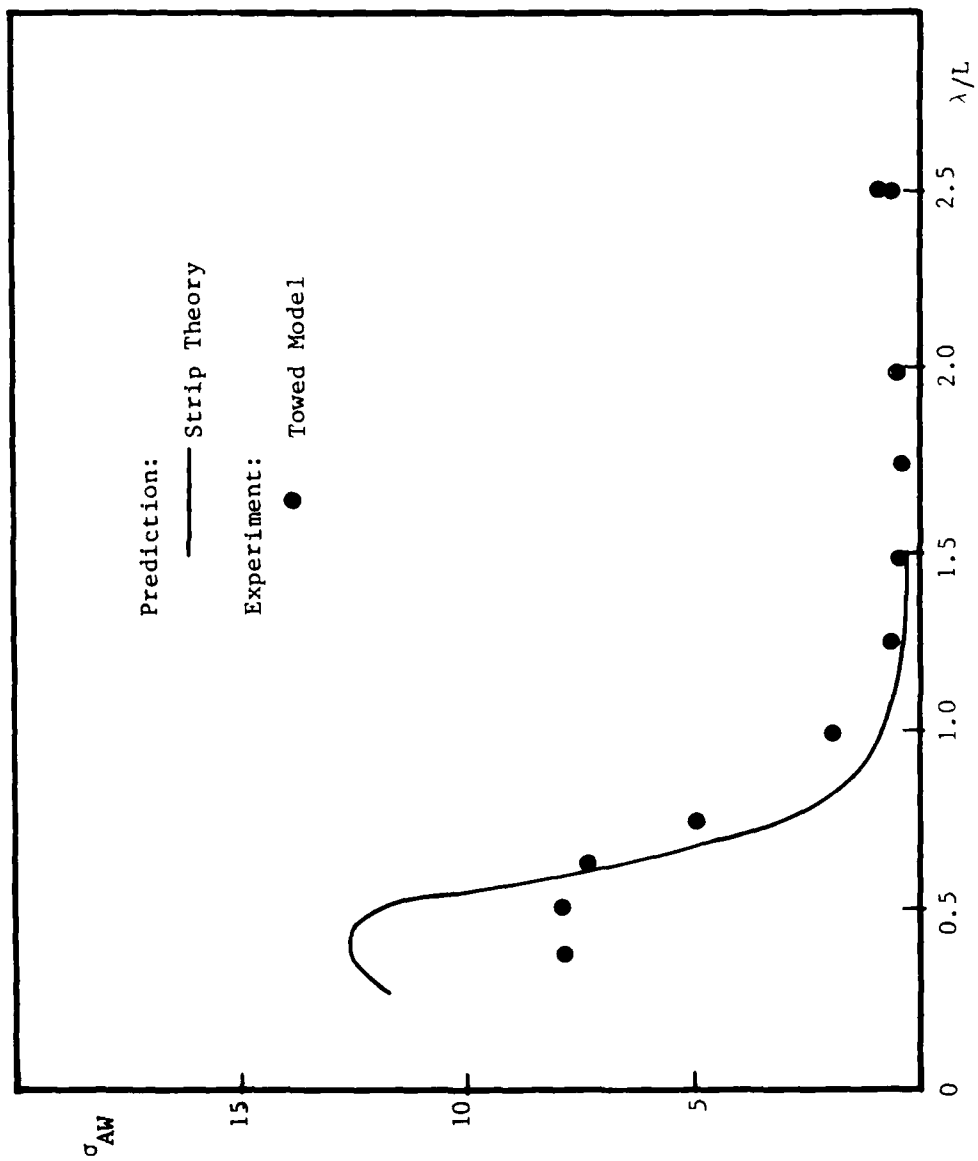

Figure 10 - Added Resistance Coefficient for Froude No.=0.15, Wave Heading=120°

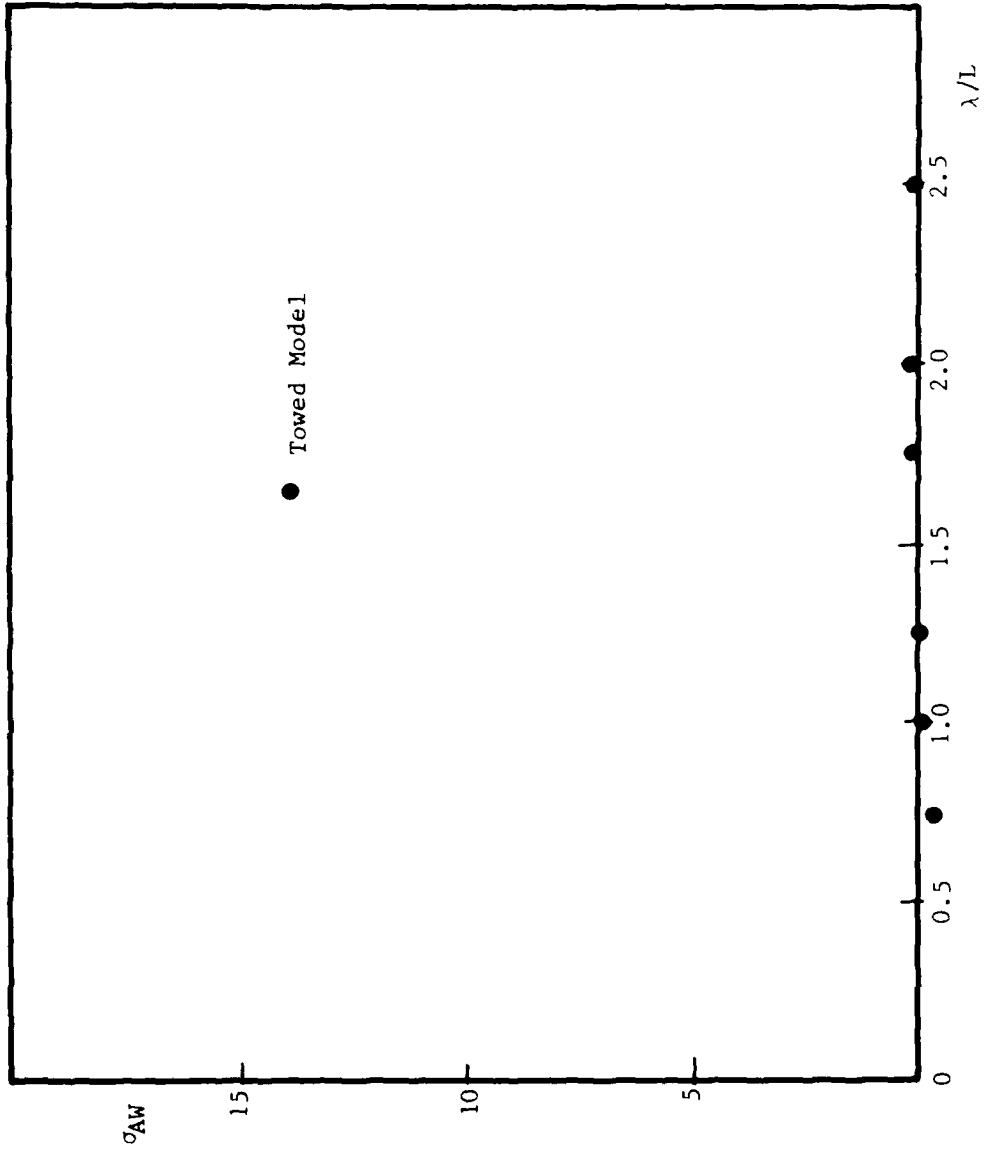

Figure 11 - Added Resistance Coefficient for Froude No.=0,15, Wave Heading=090°

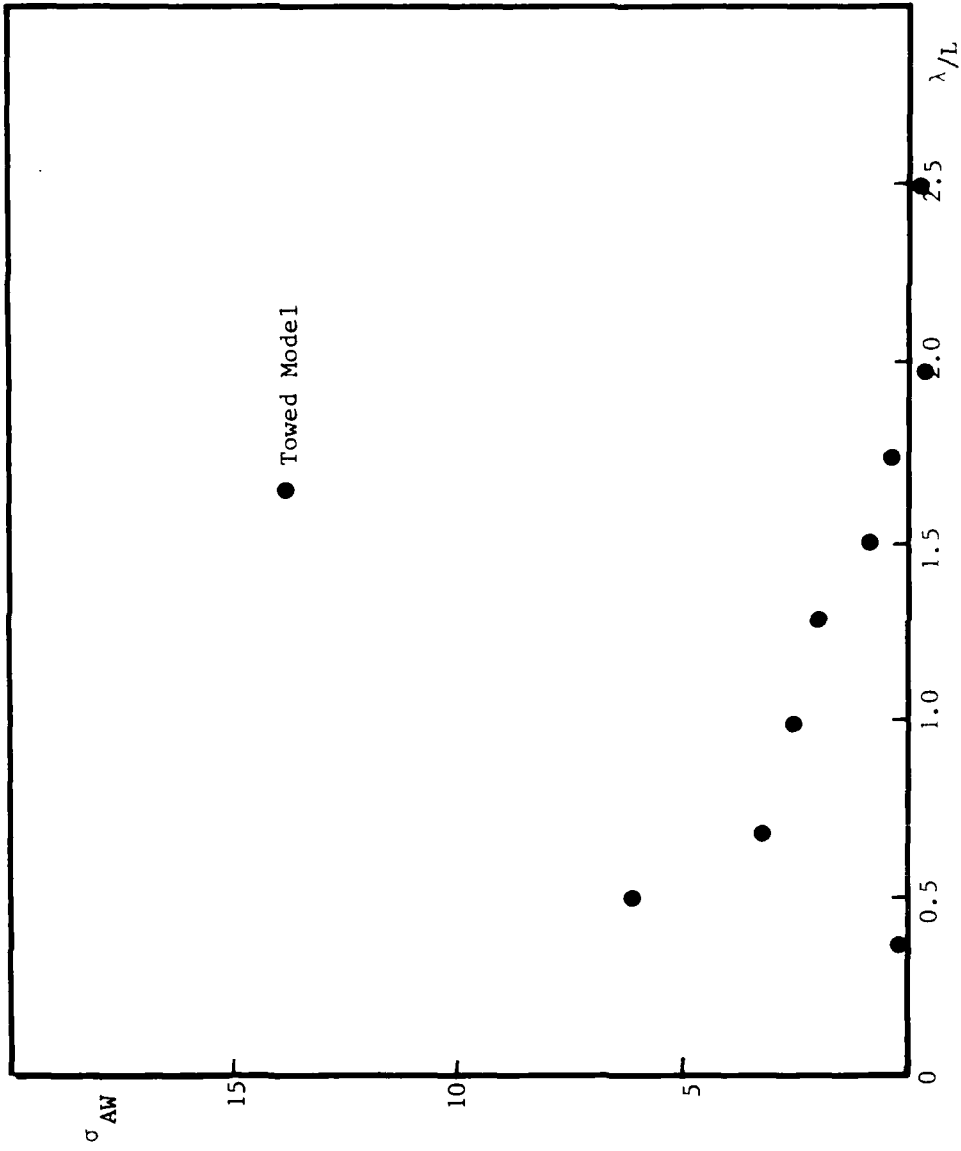

Figure 12 - Added Resistance Coefficient for Froude No.=0.15, Wave Heading=045°

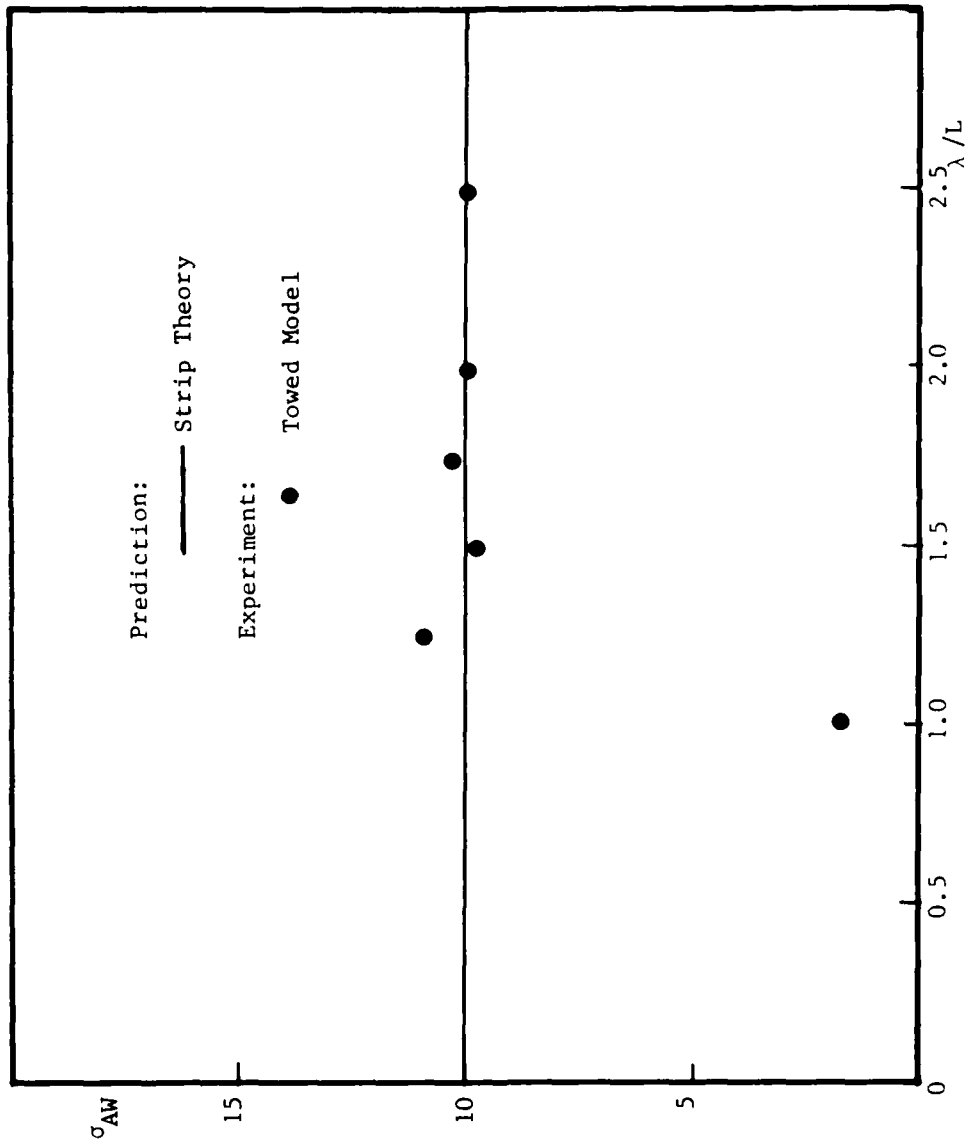

Figure 13 - Added Resistance Coefficient for Froude No.=0.15, Wave Heading=000°

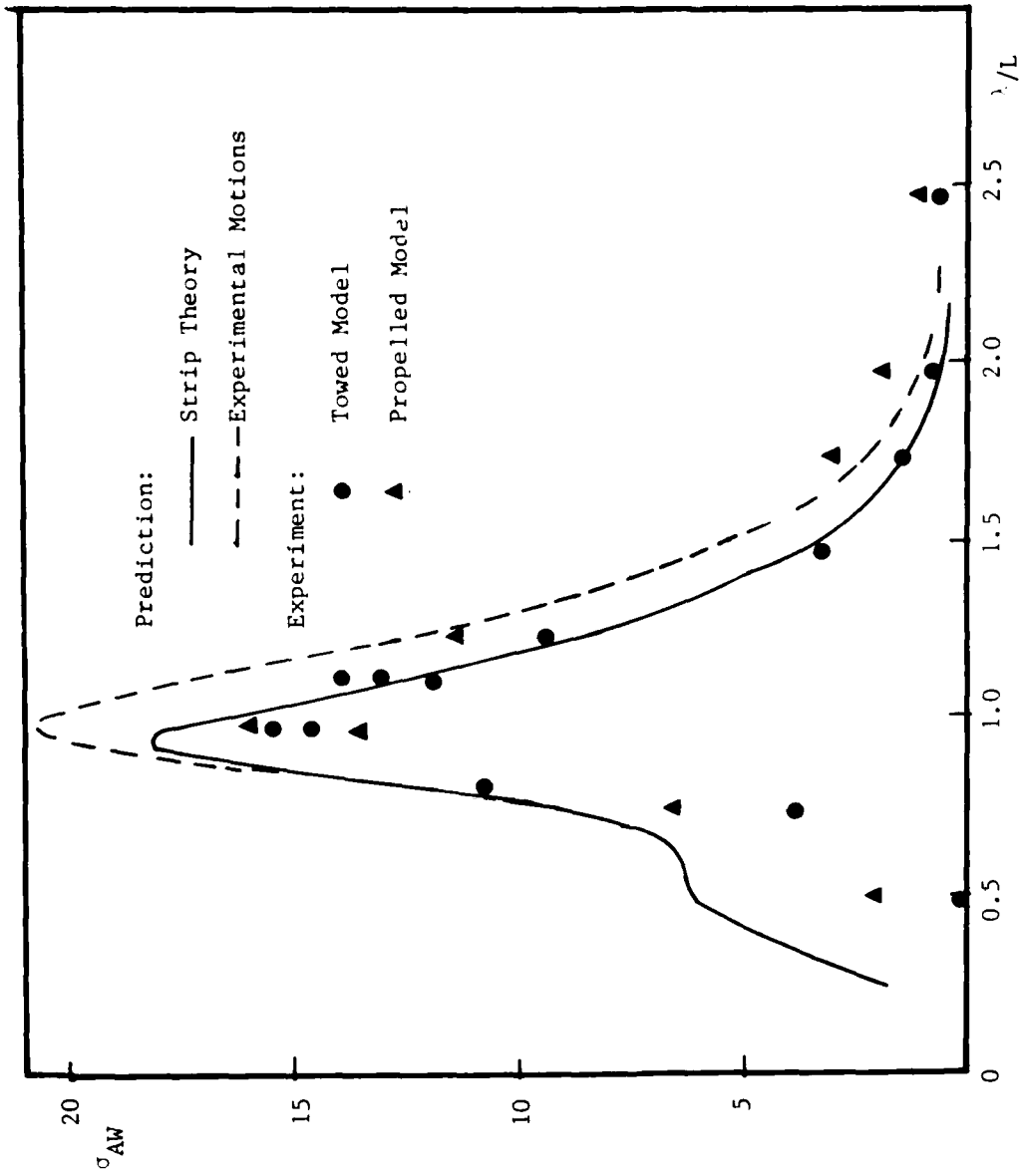

Figure 14 - Added Resistance Coefficient for Froude No.=0.30, Wave Heading=180°

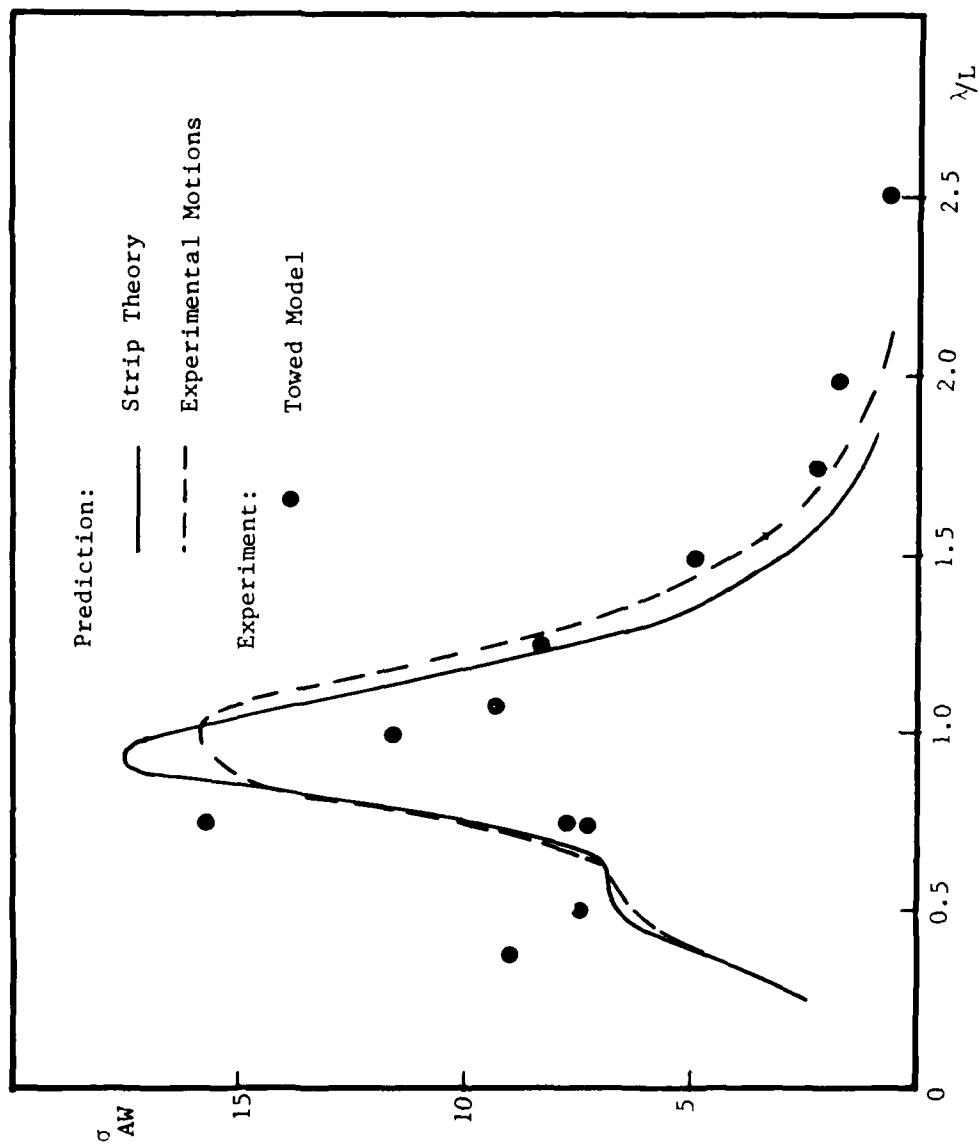

Figure 15 - Added Resistance Coefficient for Froude No.=0.30, Wave Heading=165°

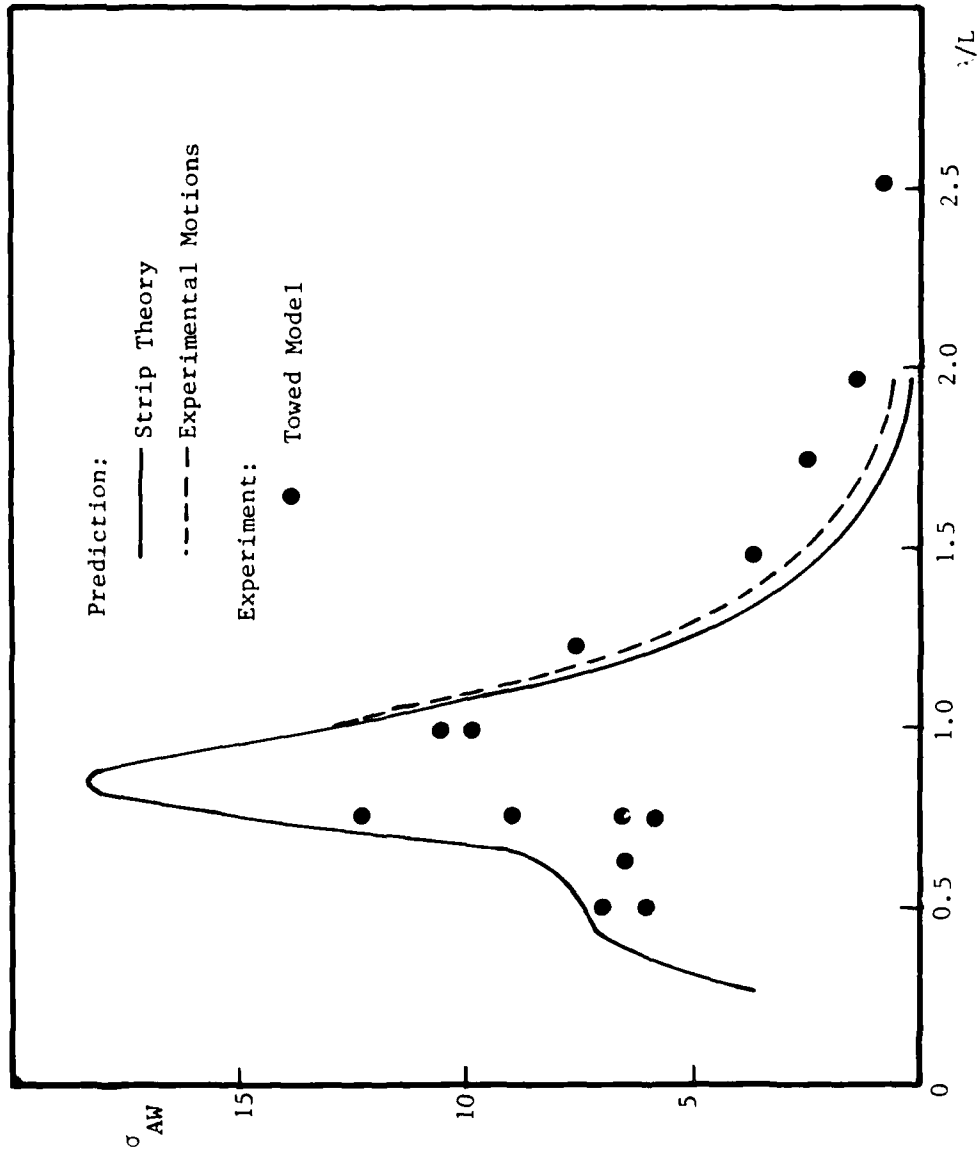

Figure 16 - Added Resistance Coefficient for Froude No.=0.30, Wave Heading=150°

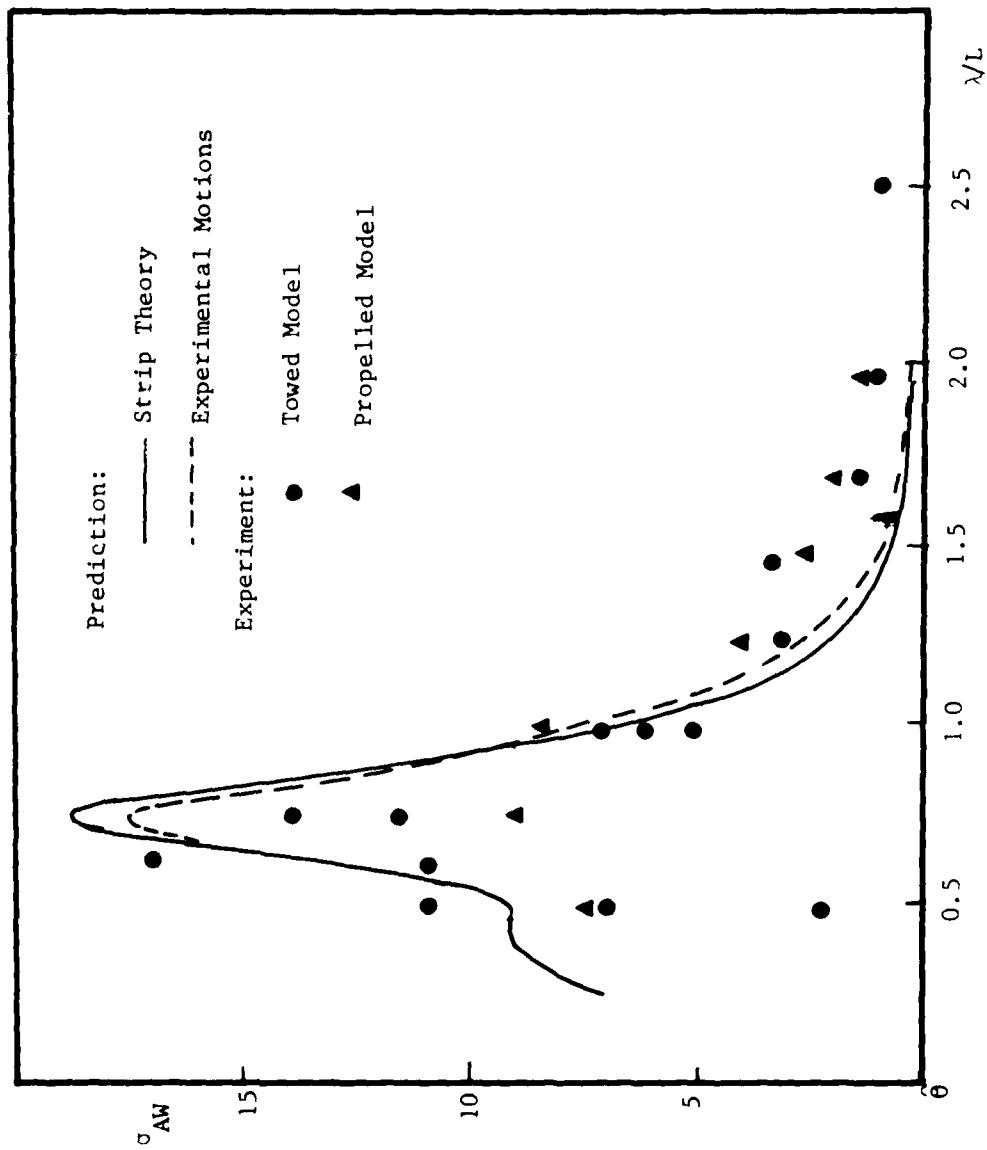

Figure 17 - Added Resistance Coefficient for Froude No.=0.30, Wave Heading=135°

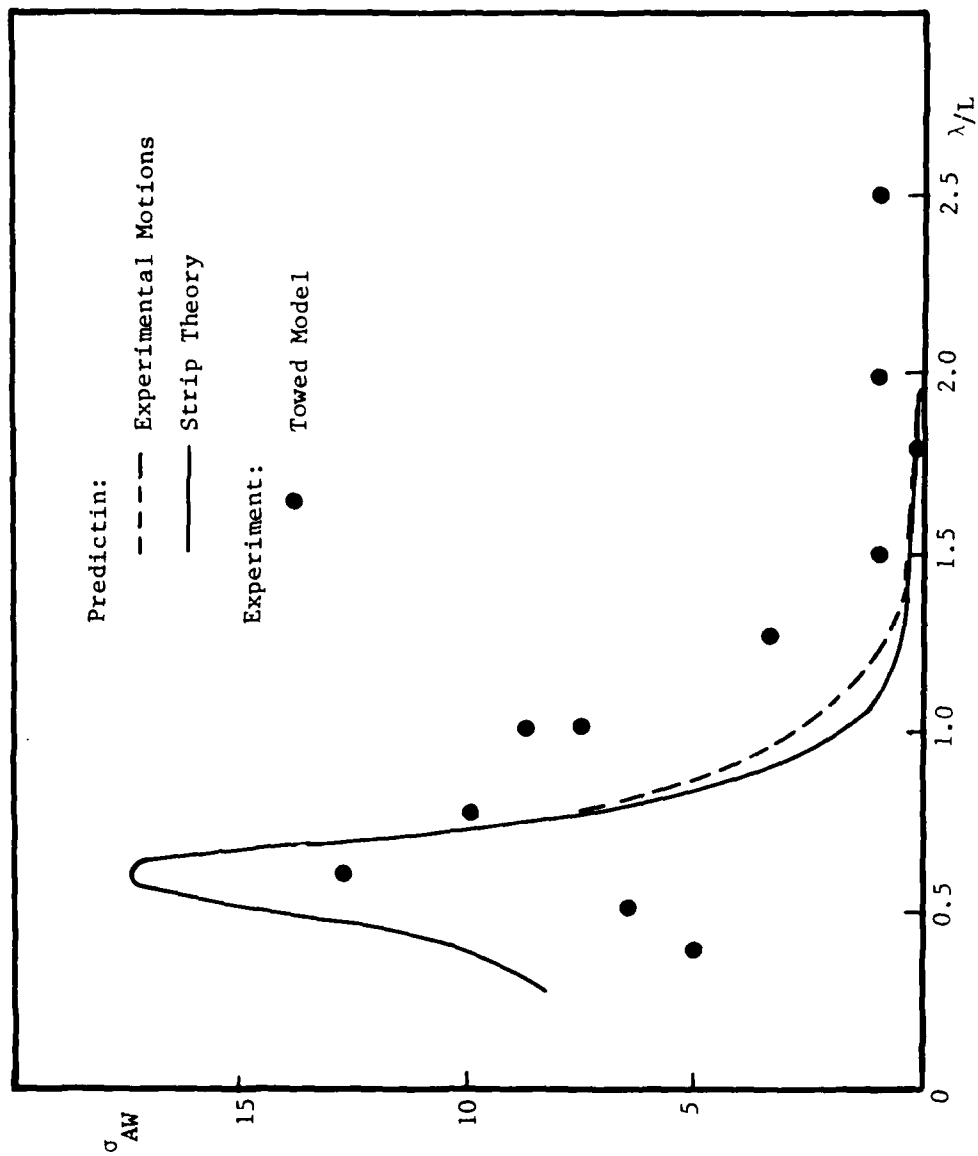

Figure 18 - Added Resistance Coefficient for Froude No.=0.30, Wave Heading=120°

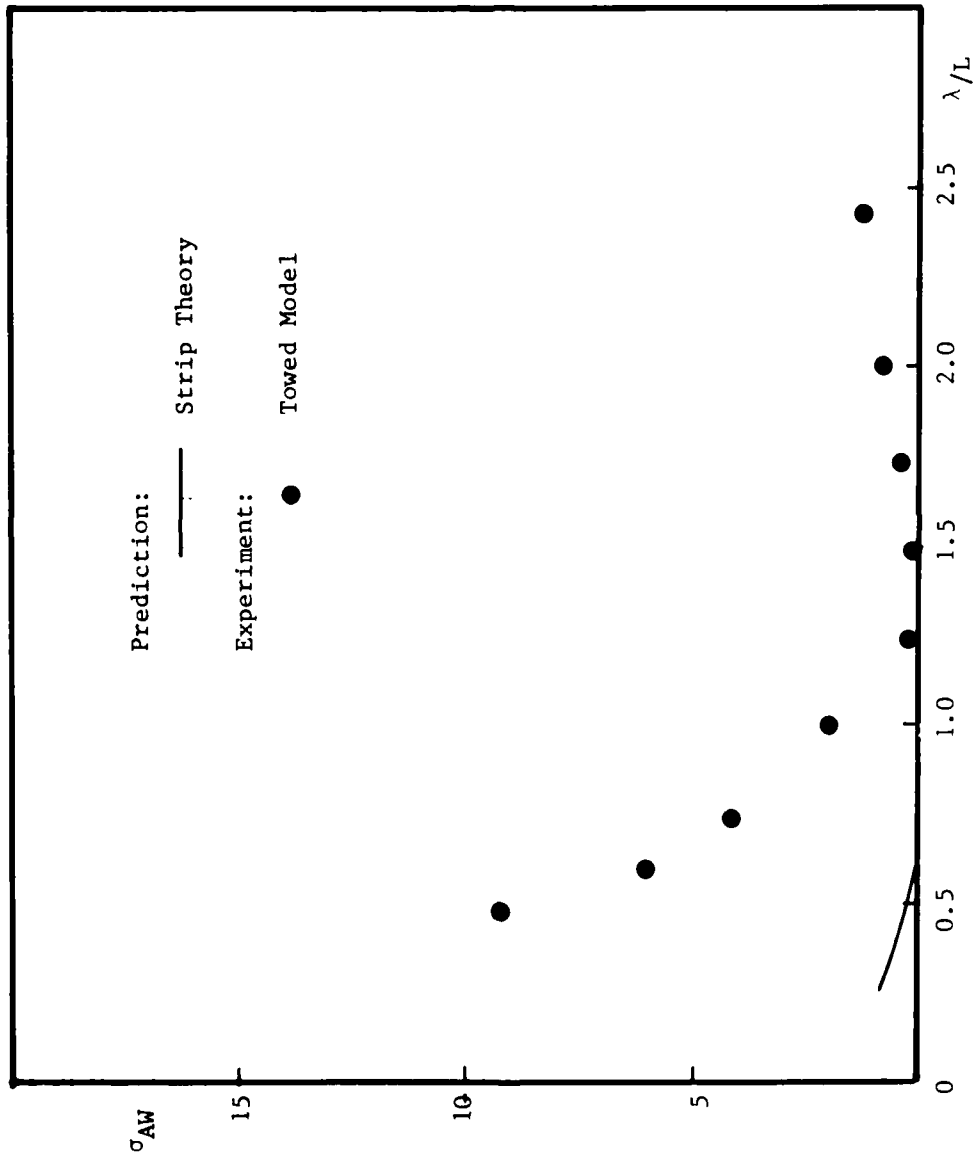

Figure 19 - Added Resistance Coefficient for Froude No. = 0.30, Wave Heading = 090°

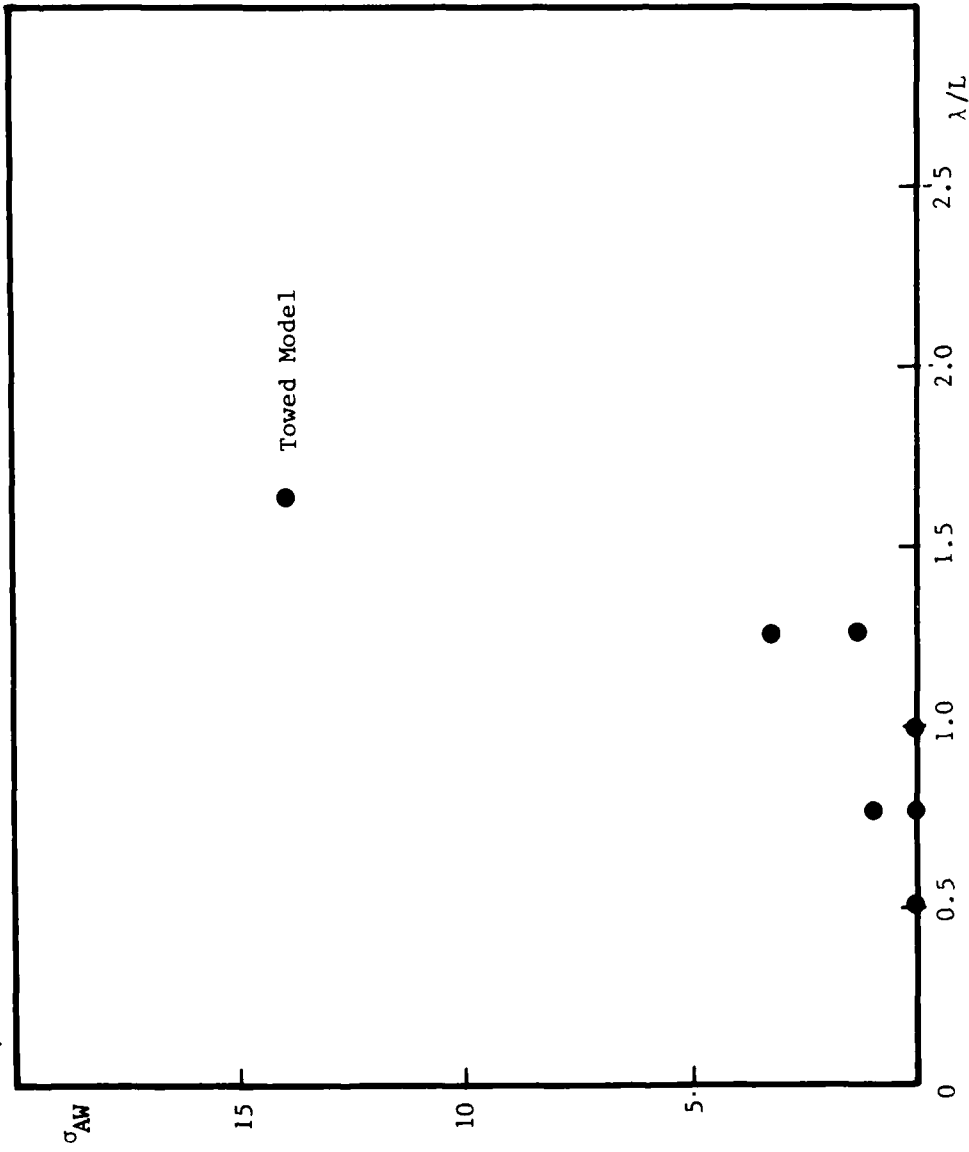

Figure 20 - Added Resistance Coefficient for Froude No.=0.30, Wave Heading=045°

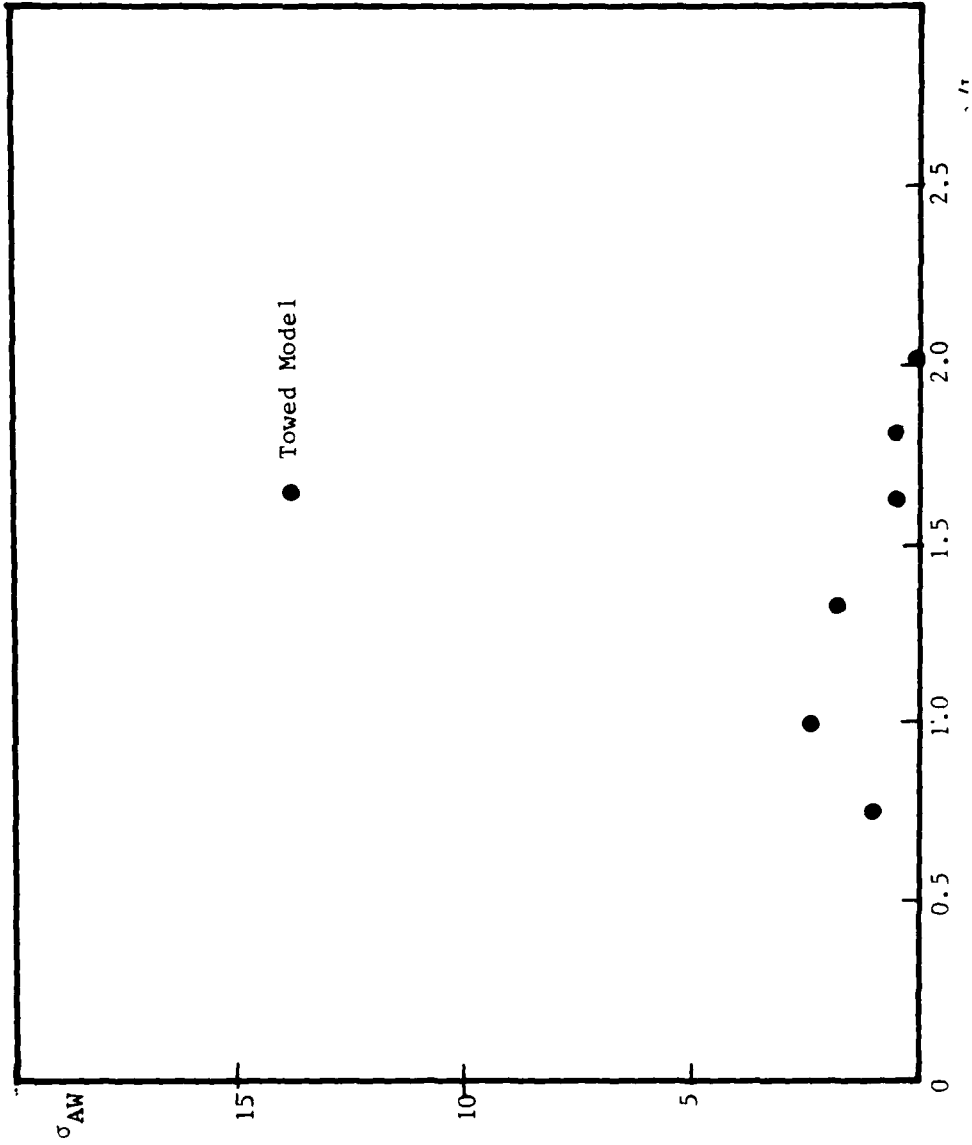

Figure 21 - Added Resistance Coefficient for Froude No.=0.30, Wave Heading=000°

DTNSRDC ISSUES THREE TYPES OF REPORTS

1. DTNSRDC REPORTS, A FORMAL SERIES, CONTAIN INFORMATION OF PERMANENT TECHNICAL VALUE. THEY CARRY A CONSECUTIVE NUMERICAL IDENTIFICATION REGARDLESS OF THEIR CLASSIFICATION OR THE ORIGINATING DEPARTMENT.

2. DEPARTMENTAL REPORTS, A SEMIFORMAL SERIES, CONTAIN INFORMATION OF A PRELIMINARY, TEMPORARY, OR PROPRIETARY NATURE OR OF LIMITED INTEREST OR SIGNIFICANCE. THEY CARRY A DEPARTMENTAL ALPHANUMERICAL IDENTIFICATION.

3. TECHNICAL MEMORANDA, AN INFORMAL SERIES, CONTAIN TECHNICAL DOCUMENTATION OF LIMITED USE AND INTEREST. THEY ARE PRIMARILY WORKING PAPERS INTENDED FOR INTERNAL USE. THEY CARRY AN IDENTIFYING NUMBER WHICH INDICATES THEIR TYPE AND THE NUMERICAL CODE OF THE ORIGINATING DEPARTMENT. ANY DISTRIBUTION OUTSIDE DTNSRDC MUST BE APPROVED BY THE HEAD OF THE ORIGINATING DEPARTMENT ON A CASE-BY-CASE BASIS.

**DAT
FILM**