

WIND TUNNEL TEST OF A SELF-OPTIMIZING FLEXIBLE
TECHNOLOGY WING



D. A. MacLanahan, Jr.
ARO, Inc.

January 1980

Final Report for Period 4-6 September and 17-22 November 1979

Approved for public release; distribution unlimited.

TECHNICAL REPORTS
FILE COPY

Property of U. S. Air Force
AEDC LIBRARY
F40600-81-C-0004

**ARNOLD ENGINEERING DEVELOPMENT CENTER
ARNOLD AIR FORCE STATION, TENNESSEE
AIR FORCE SYSTEMS COMMAND
UNITED STATES AIR FORCE**

NOTICES

When U. S. Government drawings, specifications, or other data are used for any purpose other than a definitely related Government procurement operation, the Government thereby incurs no responsibility nor any obligation whatsoever, and the fact that the Government may have formulated, furnished, or in any way supplied the said drawings, specifications, or other data, is not to be regarded by implication or otherwise, or in any manner licensing the holder or any other person or corporation, or conveying any rights or permission to manufacture, use, or sell any patented invention that may in any way be related thereto.

References to named commercial products in this report are not to be considered in any sense as an indorsement of the product by the United States Air Force or the Government.

APPROVAL STATEMENT

This report has been reviewed and approved.



GREGORY COWLEY, 1st Lt, USAF
Test Director, PWT Division
Directorate of Test Operations

Approved for publication:

FOR THE COMMANDER

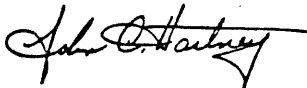

JOHN C. HARTNEY, Colonel, USAF
Director of Test Operations
Deputy for Operations

UNCLASSIFIED

REPORT DOCUMENTATION PAGE		READ INSTRUCTIONS BEFORE COMPLETING FORM
1. REPORT NUMBER AEDC-TSR-80-P3	2. GOVT ACCESSION NO.	3. RECIPIENT'S CATALOG NUMBER
4. TITLE (and Subtitle) WIND TUNNEL TEST OF A SELF-OPTIMIZING FLEXIBLE TECHNOLOGY WING		5. TYPE OF REPORT & PERIOD COVERED Final Report - Sept. 4-6 and Nov. 17-22, 1979
		6. PERFORMING ORG. REPORT NUMBER
7. AUTHOR(s) D. A. MacLanahan, Jr., ARO, Inc., a Sverdrup Corporation Company		8. CONTRACT OR GRANT NUMBER(s)
9. PERFORMING ORGANIZATION NAME AND ADDRESS Arnold Engineering Development Center Air Force Systems Command Arnold Air Force Station, TN 37389		10. PROGRAM ELEMENT, PROJECT, TASK AREA & WORK UNIT NUMBERS Program Element 62201F
11. CONTROLLING OFFICE NAME AND ADDRESS Arnold Engineering Development Center/DOS Air Force Systems Command Arnold Air Force Station, TN 37389		12. REPORT DATE January 1980
		13. NUMBER OF PAGES 20
14. MONITORING AGENCY NAME & ADDRESS (if different from Controlling Office) AEDC/DOT Arnold Air Force Station, TN 37389		15. SECURITY CLASS. (of this report) UNCLASSIFIED
		15a. DECLASSIFICATION/DOWNGRADING SCHEDULE N/A
16. DISTRIBUTION STATEMENT (of this Report) Approved for public release; distribution unlimited.		
17. DISTRIBUTION STATEMENT (of the abstract entered in Block 20, if different from Report)		
18. SUPPLEMENTARY NOTES Available in Defense Technical Information Center.		
19. KEY WORDS (Continue on reverse side if necessary and identify by block number) Computers Wind tunnel tests Control F-111 TACT Flexible structure Self-optimizing wing		
20. ABSTRACT (Continue on reverse side if necessary and identify by block number) A 1/6-scale, semispan model of an AFTI-111 concept equipped with eleven remotely controllable hydraulic actuation systems used to control wing shape and horizontal tail angle was tested in the Propulsion Wind Tunnel (16T) at free-stream Mach numbers of 0.60 and 0.85 and free-stream dynamic pressures of 400 and 500 psf. Angle of attack was varied from 0 to 8 deg. The objectives of this test were to further develop and refine a computer-controlled self-		

20. ABSTRACT. Concluded

optimizing wing for continual investigation of optimum wing
airfoil contours for specific mission profiles.

CONTENTS

	<u>Page</u>
NOMENCLATURE	2
1.0 INTRODUCTION	3
2.0 APPARATUS	
2.1 Test Facility	3
2.2 Test Article	4
2.3 Instrumentation	4
3.0 TEST DESCRIPTION	
3.1 Test Conditions and Procedures	5
3.2 Corrections	5
3.3 Data Reduction	6
3.4 Uncertainty of Measurements	6
4.0 DATA PACKAGE PRESENTATION	6
REFERENCES	7

ILLUSTRATIONS

Figure

1. Test Article Location in Tunnel 16T	8
2. Test Article Installation in Tunnel 16T	9
3. Test Article Details	10
4. Comparison of Data Repeatability	11
5. Internal Drag and Plug Drag Coefficient Corrections	12
6. Estimated Uncertainties in Wind Tunnel Parameters	13

TABLES

1. Test Program Summary	14
2. Sample Tabulated Data Printout	15
3. Tabulated Data Nomenclature	16

NOMENCLATURE

ALPHA	Model angle of attack (positive nose toward tunnel floor), deg
AT	Horizontal tail reference area, 2.4 ft ²
BL	Model buttock line, in.
BT	Horizontal tail reference span, 29.33 in.
b	Model reference span, 59.33 in.
CDI	Internal duct drag coefficient/force/QS (see Fig. 5)
CDP	Nozzle plug drag coefficient, force/QS (see Fig. 5)
CL	Lift coefficient, force/QS
CLM	Pitching-moment coefficient, moment/QSc̄
c̄	Model reference chord, 20.96 in.
DELT	Horizontal tail deflection angle (positive leading edge toward tunnel floor), deg
M	Free-stream Mach number
MRC	Model moment reference center
MS	Model station, in.
PT	Free-stream total pressure, psfa
RUN	Run number (a data subset containing variables of only one independent parameter)
S	Model reference area, 8.39 ft ²
WL	Model water line, in.
XMC	Location of the moment reference center along the model X axis, 89.272 in.
ZMC	Location of the moment reference center along the model Z axis, 29.468 in.

1.0 INTRODUCTION

The work reported herein was conducted by the Arnold Engineering Development Center (AEDC), Air Force Systems Command (AFSC). The program was sponsored by the Arnold Engineering Development Center (AEDC/DOT), for the ARO, Inc., AEDC Division, and General Dynamics, Convair Division, under Program Element 62201F. The test results were obtained by ARO, Inc., AEDC Division (a Sverdrup Corporation Company), operating contractor of the AEDC. The test was conducted in the Propulsion Wind Tunnel Facility (PWT), Propulsion Wind Tunnel (16T) during the period from September 4 through 6, 1979 and November 17 through 22, 1979, under ARO Project Number P41T-A0.

The objectives of this test were to further develop and refine a computer controlled self-optimizing wing for continued investigation of optimum wing contours for specific mission profiles. A previous series of tests of this model is reported in Ref. 1.

The purpose of this report is to document the test and to describe the test parameters. The report provides information to permit use of the data but does not include any data analysis, which is beyond the scope of this report.

Requests for data should be addressed to the Arnold Engineering Development Center (AEDC/DCT), Arnold Air Force Station, TN 37389. A copy of the final data is on file on microfilm at the AEDC.

2.0 APPARATUS

2.1 TEST FACILITY

The AEDC Propulsion Wind Tunnel (16T) is a variable density, continuous-flow tunnel capable of being operated at Mach numbers from 0.2 to 1.5 and stagnation pressures from 120 to 4000 psfa. The maximum attainable Mach number can vary slightly depending upon the tunnel pressure ratio requirements with a particular test installation. The maximum stagnation pressure attainable is a function of Mach number and available electrical power. The tunnel stagnation temperature can be varied from about 80 to 160°F depending upon the cooling water temperature. The tunnel is equipped with a scavenging system which removes combustion products when testing with rocket motors or turboengines. The test section is 16 ft square by 40 ft long.

and enclosed by 60-deg inclined-hole perforated walls of six-percent porosity. The general arrangement of the test section and the test article location is shown in Fig. 1. Additional information about the tunnel, its capabilities, and operating characteristics is presented in Ref. 2.

2.2 TEST ARTICLE

The test article was a 1/6-scale semi-span model of an AFTI-111 concept, consisting of a fuselage with a flow-through nacelle, a remotely moveable horizontal tail, and a variable geometry wing. The test article was mounted inverted on a sidewall mounted reflection plane as shown in Fig. 2. Model details are shown in Fig. 3. There were ten remotely controllable, hydraulic actuator systems used to vary wing airfoil shape and one actuator to vary the angle of the horizontal tail. The same model was used for a previous test and is described in detail in Ref. 1. Modifications to that model for this test include: improved seals between the glove and fuselage, improved hydraulic system, improved actuators and readout systems, a new wing leading edge, and the addition of a remotely variable horizontal tail.

During the September 4 through 6, 1979 entry, the wing leading edge failed. Therefore, another leading edge was designed and fabricated for the November entry. Additional model modification details are documented in Ref. 3.

2.3 INSTRUMENTATION

A newly designed, fabricated, and calibrated five-component strain gage balance was used to measure the total forces and moments on the model. A strain gage instrumented rod was used to determine the hinge moment for the horizontal tail. The wing spar was instrumented near the root with strain gages to determine the wing root bending moment. Model pitch angle was determined from the output of a synchrotransmitter. An angular position indicator was mounted in the nose of the model to give an independent angle of attack reading. Actuator positions (including tail positions) were determined from potentiometer outputs. Model mounted pressure transducers were used to determine hydraulic pressures, two wing trailing edge pressures, four internal wing pressures (two near the leading edge and two near the trailing edge), and two wing surface static pressures.

Electrical signals from all instrumentation were digitized for on-line data reduction and displayed by the facility computer. Data were transmitted to an IBM 370/165

computer for on-line data evaluation and comparative analysis using an interactive graphics system.

3.0 TEST DESCRIPTION

3.1 TEST CONDITIONS AND PROCEDURES

Data were obtained by establishing the desired tunnel conditions and recording steady-state data. Data were obtained at Mach numbers 0.6 and 0.85. There were three types of runs: (1) preliminary pitch runs, (2) optimization runs and evaluation pitch runs, and (3) parametric runs. For the preliminary pitch runs and the evaluation pitch runs, data were obtained over an angle-of-attack range of 0 to about 8 deg. Some parametric runs were made where the horizontal tail was varied from -4 to 10 deg to determine the effects of tail position on the pitching moment. Other parametric runs were made where the wing airfoil shape actuators were varied over their operating range.

For optimization runs, the wing shape, angle of attack, and tail deflection angle were varied in a manner to maximize or minimize various merit functions. The merit function for this test minimized drag coefficient at a constant lift coefficient.

All steady-state measurements were sequentially recorded by the facility on-line computer system, which reduced the data to engineering units, further processed the data to obtain the required model parameters, tabulated the data in the Tunnel 16T control room, recorded the data on magnetic tape, and transmitted the data to the AEDC central computer file. The data stored in the central computer file were generally available for plotting and analysis on the PWT Interactive Graphics System within 30 seconds after data acquisition. The immediate availability of the tabulated and plotted data permitted continual on-line monitoring of the test results. A typical data plot generated by the Interactive Graphics System is shown in Fig. 4. For this test, data from the previous entry, Ref. 1, were also stored on the AEDC central computer file for comparison.

3.2 CORRECTIONS

The model attitude was corrected for balance deflections. Based on the results for the previous entry, Ref. 1, the drag was corrected for plug drag and internal duct drag (see Fig. 5). Model forces and moments were corrected for static weight tares.

3.3 DATA REDUCTION

The forces and moments and pressures were nondimensionalized using the model reference constants (b , \bar{c} , and S), and were resolved into the body axes system about the moment reference center, which is shown in Fig. 3. The horizontal tail hinge moment was referenced to the tail hinge line (see Fig. 3), positive leading edge toward the floor, and nondimensionalized using the tail reference constants (AT, BT).

3.4 UNCERTAINTY OF MEASUREMENTS

Uncertainties (combinations of systematic and random errors) of the basic tunnel parameters, shown in Fig. 6, were estimated from repeat calibrations of the instrumentation and from the repeatability and uniformity of the test section flow during tunnel calibration. Uncertainties in the instrumentation systems were estimated from repeat calibration of the systems against secondary standards whose uncertainties are traceable to the National Bureau of Standards calibration equipment. The tunnel parameter and instrument uncertainties, for a 95% confidence level, are combined using the Taylor series method of error propagation described in Ref. 4 to determine the uncertainties of the reduced parameters shown below.

<u>M</u>	<u>ALPHA, deg</u>	<u>±UCL</u>	<u>±UCD</u>	<u>±UCLL</u>	<u>±UCLM</u>	<u>±UCLN</u>
0.60	0	0.0039	0.0012	0.0013	0.0011	0.0007
0.85	0	0.0031	0.0009	0.0011	0.0008	0.0006
0.85	4	0.0036	0.0012	0.0017	0.0009	0.0006

Figure 4 shows a comparison of repeat data. In both runs data were obtained while increasing and decreasing angle of attack to show any hysteresis effects.

4.0 DATA PACKAGE PRESENTATION

The data package contained 1) tabulated data sheets listing all test parameters, 2) digital magnetic computer tapes, 3) test article installation photographs, 4) appropriate test logs for identification of test runs and test conditions, and 5) a copy of this test summary report. An example of the tabulated data is shown in Table 1. All parameters on the data are defined in Table 2.

REFERENCES

1. Levinsky, E. S., Palko, R. L., et al. "Semispan Wind Tunnel Test Evaluation of a Computer-Controlled Variable Geometry Wing." AEDC-TR-78-51 (ADBO33600L), January 1979.
2. Test Facilities Handbook (Eleventh Edition). "Propulsion Wind Tunnel Facility, Vol. 4." Arnold Engineering Development Center, June 1979.
3. Levinski, E. S., et al. "Pretest Report Second Wind Tunnel Test of a Self-Optimizing Flexible Technology (SOFT) Wing 1/6-Scale Semispan Model in AEDC Tunnel 16T." TR-79-CRAD-01P, July 19, 1979.
4. Abernethy, R. B. and Thompson, J. W., Jr. "Handbook - Uncertainty in Gas Turbine Measurements." AEDC-TR-73-5 (AD755356), February 1973.
5. "1/6th-Scale Data." Received from General Dynamics/ Fort Worth, Report FZT-595-016, January 1973.

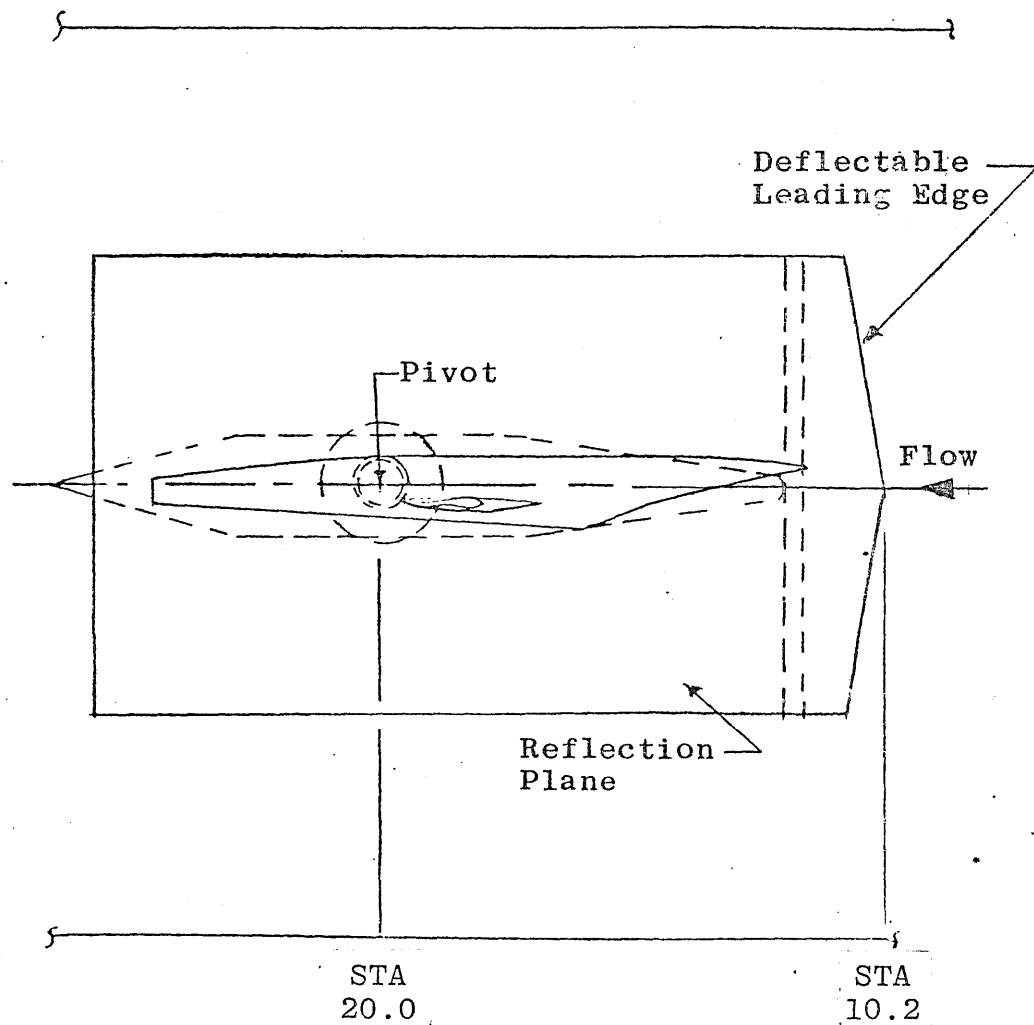

View Looking to East Wall

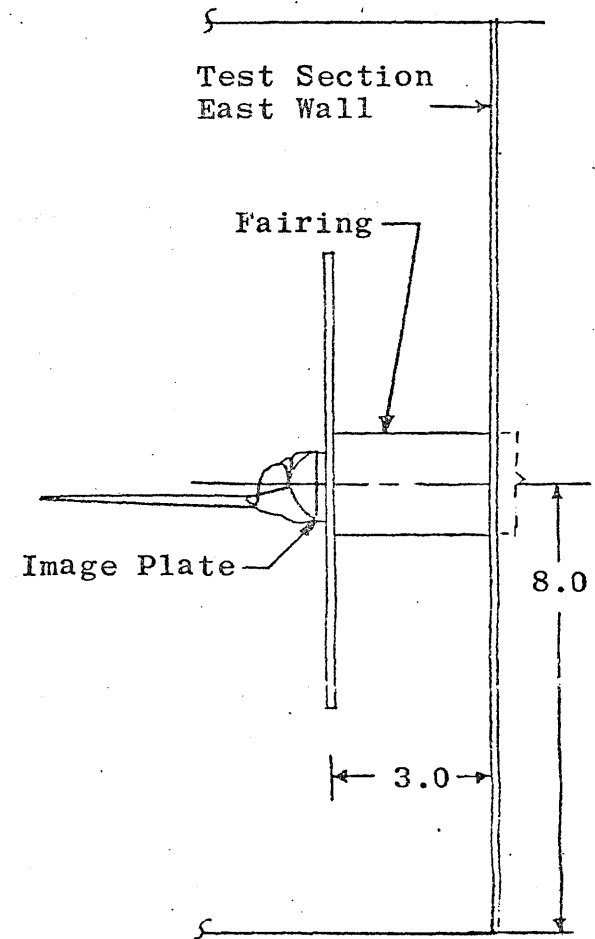

View Looking Downstream

Dimensions and Stations in Feet

Figure 1. Test Article Location in Tunnel 16T

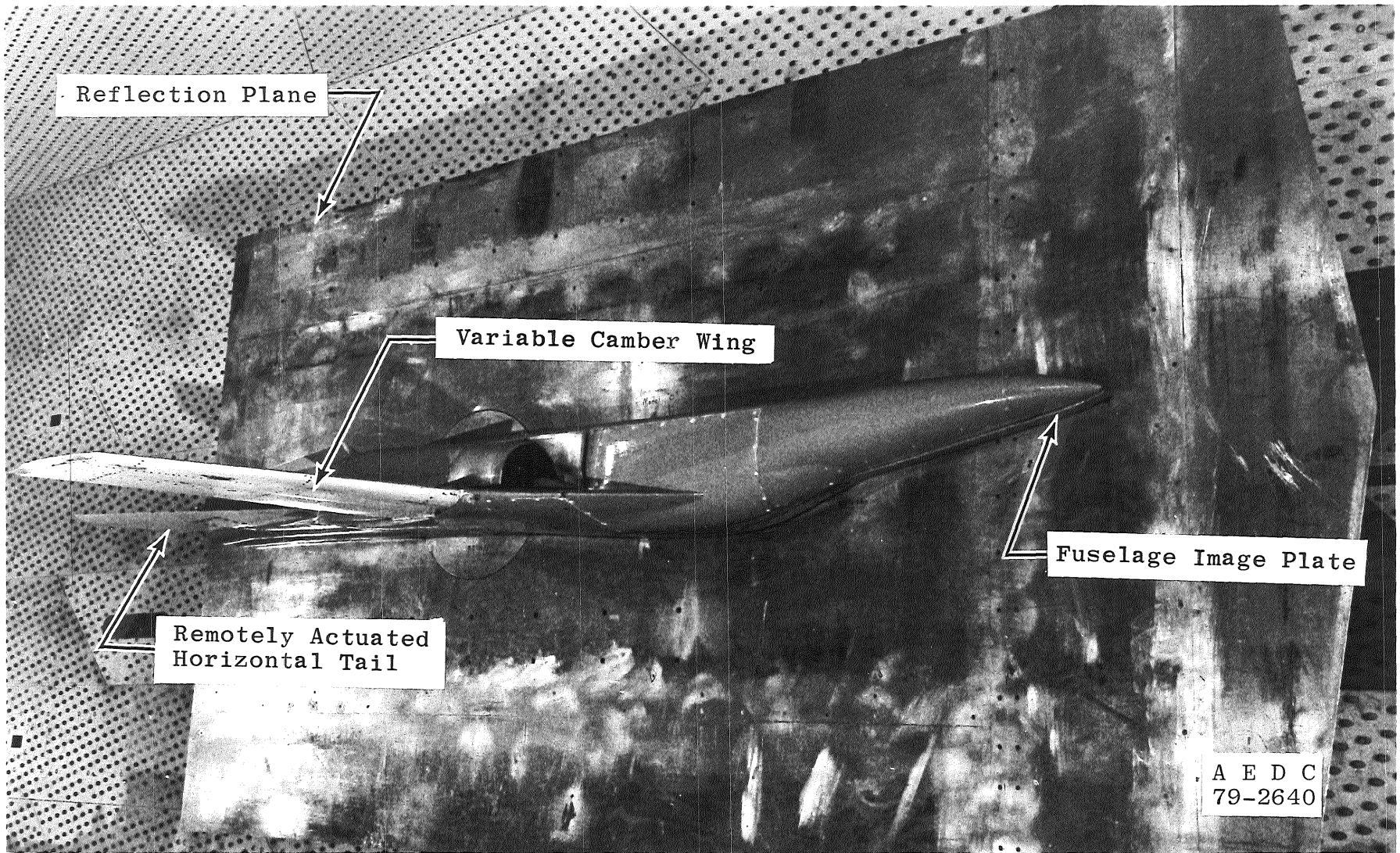
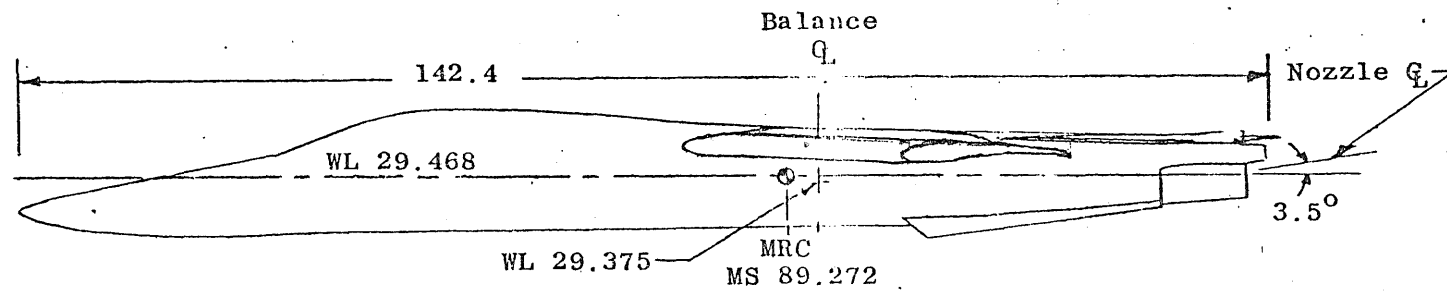
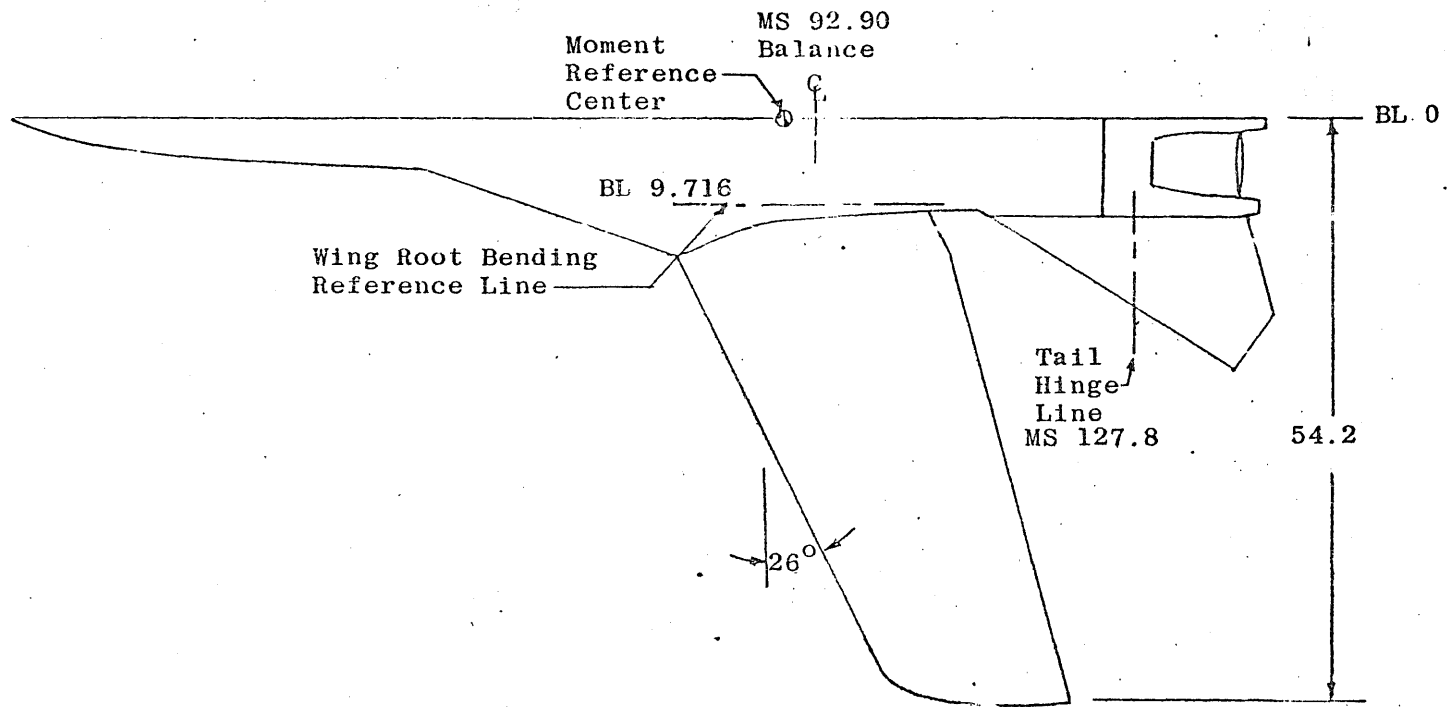

Figure 2. Test Article Installation in 16T



Stations and Dimensions in Inches
Center of Rotation about Balance Centerline

Figure 3. Test Article Details

+ PART NUMBR 293.003
* PART NUMBR 294.003

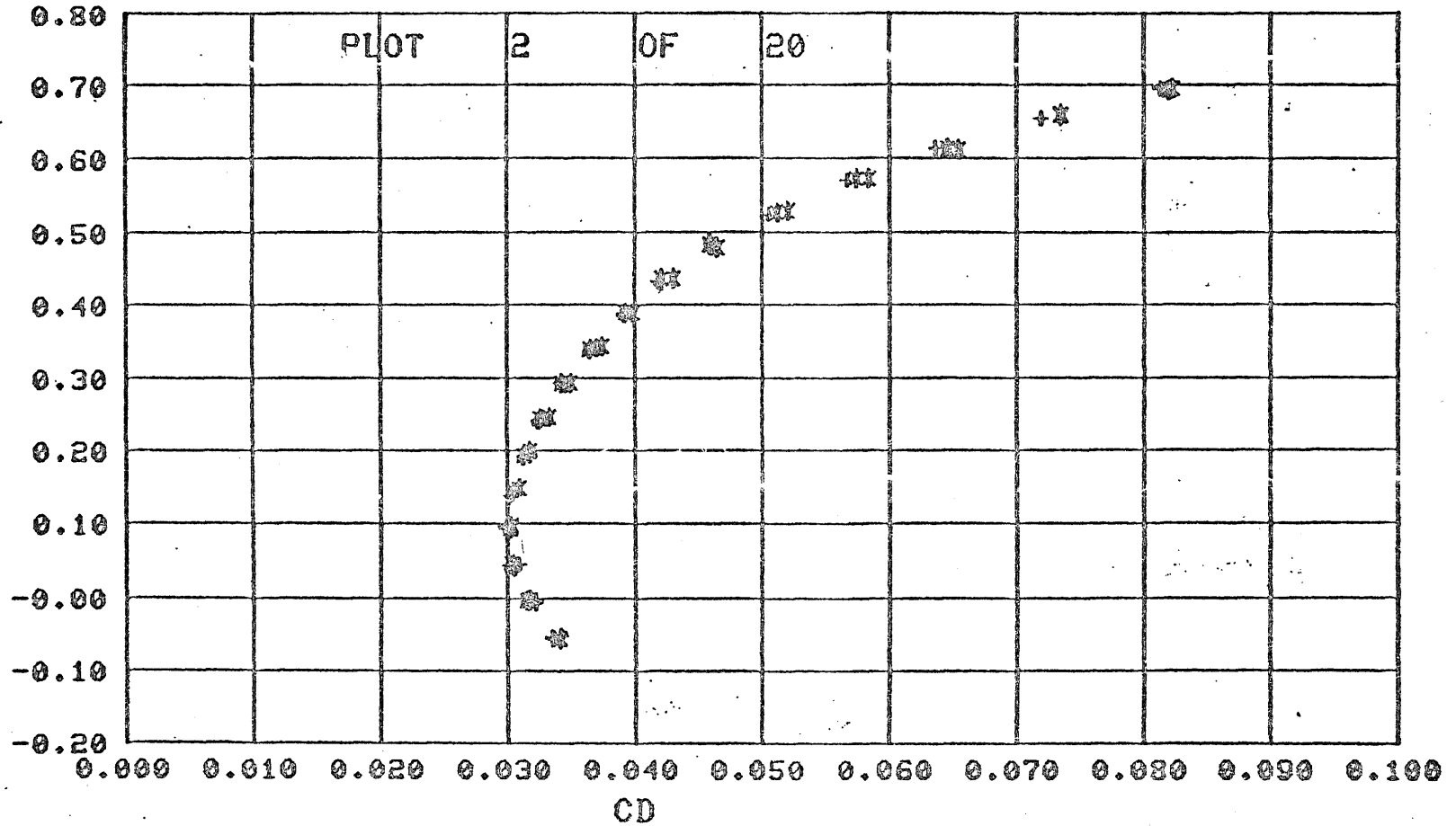

Figure 4. Comparison of Data Repeatability

UNCLASSIFIED

11

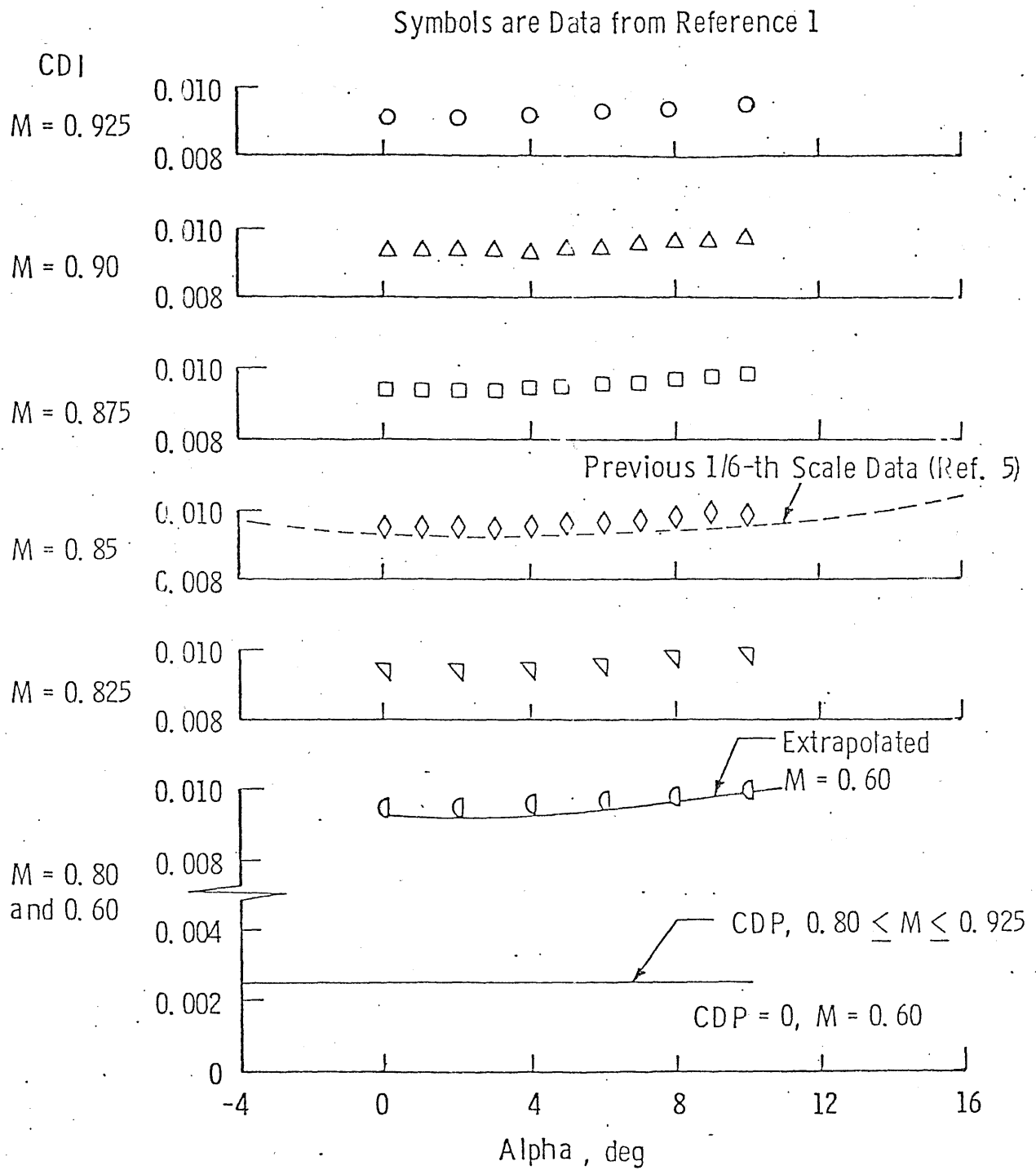

Figure 5. Internal Drag and Plug Drag Coefficient Corrections

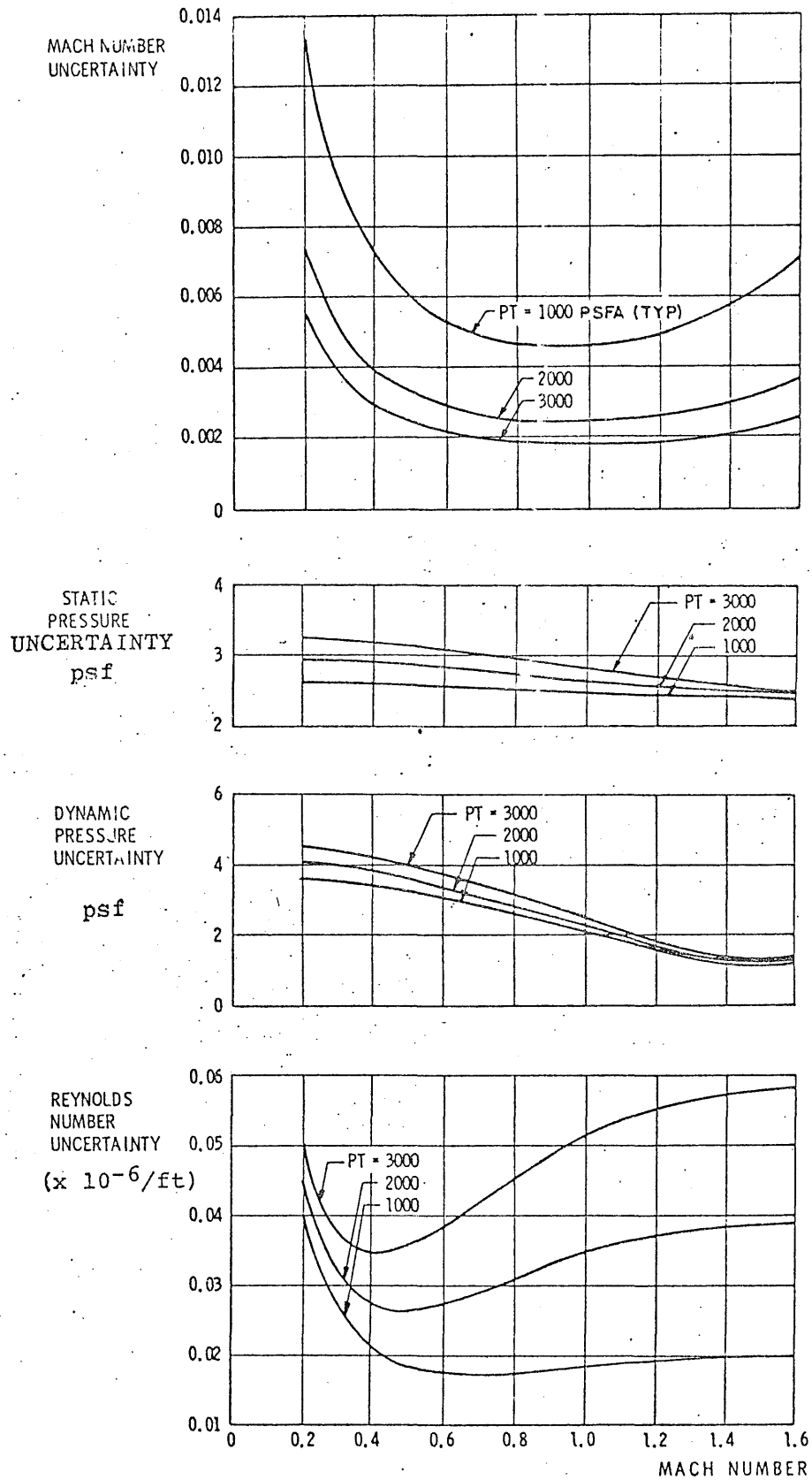

Figure 6. Estimated uncertainties in wind tunnel parameters.

Table 1. Test Program Summary

Run	M	ALPHA	DELTA	Comments
221	0.60	Vary	-4	W52 (baseline) leading edge failed
240	0.85	Vary	-4	W52 (off contour)
242	↓	↓	↓	W52
243	↓	↓	Vary	Parametric (CL-CLM)
244	↓	↓	-4	W52
246	0.60	↓	↓	W52
247	↓	↓	↓	W52
248	0.85	↓	↓	W52
249	↓	↓	Vary	Parametric (CL-CLM)
250	↓	↓	↓	Preliminary (CL Trim Table)
251	↓	↓	-4	Optimization (CL=0.4) (No Convergence)
252	↓	↓	Vary	Optimization (CL=0.25 (No Convergence)
253	↓	↓	-4	Parametric (Actuators)
254	↓	↓	↓	Parametric (Actuators)
257	↓	↓	↓	W52
258	↓	↓	↓	Optimization (CL=0.4) Untrimmed
259	↓	↓	↓	Evaluation
260	↓	↓	Vary	Parametric (CL-CLM)
261	↓	↓	↓	Preliminary (CL Trim Table)
262	↓	↓	-4	W52
263	↓	↓	↓	Evaluation
264	↓	↓	↓	Evaluation
265	↓	↓	Vary	Optimization (CL=0.4) Trimmed
266	↓	↓	-4	Evaluation
267-269	↓	↓	↓	Evaluation (Hysteresis Check)
293-295	0.60	Vary	-4	W52 (Hysteresis Check)
296	↓	↓	4	" "
297	0.85	↓	-4	" "
298	↓	↓	↓	Optimization (CL=0.50 Untrimmed)
299	↓	↓	Vary	Parametric (CL-CLM)
300	↓	↓	↓	Preliminary CL Trim Table)
300	↓	↓	↓	Optimization (CL=0.50 Trimmed) failed to change Run No.)
302	↓	↓	↓	Optimization (CL=0.25 Trimmed)
304	↓	↓	↓	Evaluation
305	↓	↓	↓	W52

Table 2. Sample Tabulated Data Printout

ARO, INC.
 AEDC DIVISION
 A SVERDRUP CORPORATION COMPANY
 PROPULSION WIND TUNNEL
 AMNOLD AIR FORCE STATION, TENNESSEE

RN	PN	PROJECT	TEST	DATE	DAY	HR	MIN	SEC	MODE	DELPI	PROD DATE	WINDOFF	SET	CAR1	TRANSONIC 16T
221	14	P411-A0A	TF-531	9/ 6/79	2491	5116151			9	352	6-SEP-79	2207	1	10	2.
M	PT	P	Q	REX10-6	TT	TTR	H		PC	DP	WA	TPR	SHX10-3		
600	2527.8	1982.1	499.1	3.873	102.2	568.9	1798.		1999.8	528.0	0.01	1.155	13.903		
ALPHAM	ALPHAM	ALPHA	DELTA	ALPHA1	ALFD				ALPHAT	DEFLT	DELT	CBOX	SWEEP		
5.90	6.90	5.94	-0.03	5.90	6.01				-4.13	0.06	-4.07	100400	26		
A11	A12A	A12B	A13	A15	A16	A21	A22A	A22B	A23	A25	A26				
32.	76.	-202.	240.	249.	253.	73.	176.	286.	149.	257.	303.				
U.00	-3.48	-9.05	-0.79	-0.01	0.05	0.00	-1.48	0.72	-2.01	0.15	1.05				
BODY	CNU	CAU	CN	CA	CLL	CLM	CLN	CAC	CAP						
AXIS	0.5145	0.0177	0.5145	0.0177	0.3905	0.1264	0.0009	0.0177	0.0000						
STABILITY	CL	CD	CLLS	CLMS	CLNS	CDU	CDI	CUP							
AXIS	0.5100	0.0610	0.3885	0.1264	-0.0393	0.0705	0.0095	0.0000							
DR1	DR2	DR4	DR5	DR6	L1	L2	L4	L5	L6	FNST	FYST	MNST	MMST	MNST	
0.9297	0.2444	-2.5288	1.4369	0.0636	2159.	-18697.	75683.	1873.		4.6	130.0	210.0	-7.9	2454.	
FNG	FYG	MLO	MMG	MNG	FN	FY	ML	MM	MN	FNAC	FAAC	MLAC	MMAC	MNAC	
2159.	56.	-18697.	75683.	1873.	2159.	-74.	-18907.	75691.	-581.	2155.	74.	9702.	11097.	442.	
R M S	RRMS	AHRMS	STEADY	RB	MLT	COEFFICIENTS	CRB	CRT							
	0.0	0.0	STATE	32409.1	135.0		64.9228	0.0038							
MODEL	PTE1	PTE2	PWLE1	PWLE2	PWLE3	PWTE1	PWTE2	PWTE3	HYDRAULIC	PSBY	PSLEE	PSLED	PSTED		
PRESSURES	1988.2	1990.6	1989.8	1990.5	1999.8	2004.7	1995.5	1999.8	PRESSURES	795.	961.	959.	961.		
COEFFICIENTS	0.0121	0.0169	0.0154	0.0167	0.0354	0.0451	0.0267	0.0354							
TUNNEL FLOOR	P101	P102	P103	P104	P105	CEILING	P106	P107	P108	P109	P110				
PRESSURES	1999.8	1999.8	1999.8	1999.8	1999.8		1999.8	1999.8	1999.8	1999.8	1999.8				
RATIOS	1.0089	1.0089	1.0089	1.0089	1.0089		1.0089	1.0089	1.0089	1.0089	1.0089				

15

Table 3. Tabulated Data Nomenclature

Line 1

RN	Run number (a data subset containing variables of only one independent parameter)
PN	Point number (a single record of test variables)
PROJECT	AEDC project number
TEST	AEDC test number
DATE	Date on which the data were obtained
DAY HR MIN SEC	The day, hour, minute, and second the data were obtained
MODE	Data mode code
DELPI	Primary input detection and selection mode
PROD DATE	Date the data were computed
WINDOFF	Wind-off RUN/PN used to reduce the data
SET	Constant set used to reduce data
CART	Test cart number

Line 2

M	Free-stream Mach number
PT	Free-stream total pressure, psfa
P	Free-stream static pressure, psfa
Q	Free-stream dynamic pressure, psf
REX10-6	Free-stream unit Reynolds number, per ft
TT	Free-stream total temperature, °F
TTR	Free-stream total temperature, °R
H	Free-stream pressure altitude, ft

Table 3. Continued

PC	Tunnel plenum pressure (used as reference pressure for transducers), psfa
DP	Differential pressure (PT-PC), psf
WA	Average test section wall angle, deg
TPR	Tunnel pressure ratio
SHx10+3	Free-stream specific humidity, lb/lb

Line 3

ALPHAM	Model angle of attack referenced to a model waterline plane (positive nose toward tunnel floor), deg
ALPHAW	Wing angle of attack referenced to the wing reference chord plane (one degree of incidence), deg
ALPHA	Model pitch indicator position, deg
DELR	Model deflection in the pitch plane due to airloads, deg
ALPHA1	Model angle of attack as determined by pitch indicator and balance deflection, deg
ALFD	Model angle of attack as determined by a model-mounted angular position indicator, deg
ALPHAT	Horizontal tail position angle (positive leading edge toward the floor), deg
DEFLT	Horizontal tail deflection due to airloads (positive leading edge toward the floor), deg
DELT	Total horizontal tail deflection angle, deg
CBOX	Constant box output
SWEEP	Wing sweep angle, deg

Table 3. Continued

Line 4

All → A26 Wing actuator positions in counts

Line 5

CNU Balance normal-force coefficient, force/QS

CAU Balance axial-force coefficient, force/QS

Body Axis System

CN Normal-force coefficient, force/QS

CA Axial-force coefficient, force/QS

CLL Rolling-moment coefficient, moment/QS_b

CLM Pitching-moment coefficient, moment/QS_c

CLN Yawing-moment coefficient, moment/QS_b

CAC Axial-force coefficient corrected for plug axial force (CA-CAP), force/QS

CAP Plug axial-force coefficient, force/QS

Line 6 Stability Axis System

CL Forebody lift coefficient, force/QS

CD Forebody drag coefficient, force/QS

CLLS Rolling-moment coefficient, moment/QS_b

CLMS Forebody pitching-moment coefficient, moment/QS_c

CLNS Yawing-moment coefficient, moment/QS_b

CDU Forebody drag coefficient not corrected for duct induced drag, force/QS

CDI Internal duct drag coefficient, force/QS

CDP Plug drag coefficient, force/QS

Line 7

DR1 → DR6 Balance differential readings (wind-on minus wind-off), volts

Table 3. Continued

Line 7 - continued

L1 + L6 Balance gage loads, lb or in.-lb
 FNST→MNST Static tare forces and moments, balance axis, lb or in.-lb

Line 8

FNG-MNG Gross forces and moments, balance axis, lb or in.-lb
 FN + MN Net forces and moments, balance axis, lb or in.-lb
 FNAC→MNAC Net forces and moments, model axis system, lb or in.-lb

Line 9

RBRMS Root-mean-square of the wing root bending moment, referenced to buttock line 9.716 in., in.-lb
 AWRMS Root-mean-square of the wing tip accelerometer, g's
 RB Wing root bending moment, in.-lb
 MLT Horizontal tail hinge moment, in.-lb
 CRB Wing root bending moment coefficient
 CHT Horizontal tail hinge moment coefficient, $MLT/Q(AT)BT$

Line 10

PTE1 Wing surface static pressures, and pressure coefficients, located near trailing edge at midspan, psfa for pressures
 PTE2
 PWLE1+3 Internal leading edge wing static pressures, and pressure coefficients, psfa for pressures

Table 3. Concluded

Line 10 - Continued

PWTEL→3	Internal trailing edge wing static pressures, and pressure coefficients, psfa for pressures
PSBV	Blocking valves supply pressure, psi
PSLEE	Leading edge extension actuator supply pressure, psia
PSLED	Leading edge deflection actuator supply pressure, psia
PSTED	Trailing edge deflection actuator supply pressure, psia

Line 11

P101 → P110	Tunnel floor and ceiling surface static pressures, psfa. Ratios are ratioed to free-stream static pressure
-------------	--