

AD-A106 999

LOGICON INC SAN DIEGO CA TACTICAL AND TRAINING SYSTE--ETC F/G 5/9  
PROTOTYPE EQUIPMENT STUDENT GUIDE FOR ACE (AIR INTERCEPT CONTRO--ETC(U)  
SEP 81 N M SMITH, R D GRANBERRY, R HALLEY N61339-78-C-0182  
8641-A00A NAVTRAEQUIPC-78-C-0182-10 NL

UNCLASSIFIED

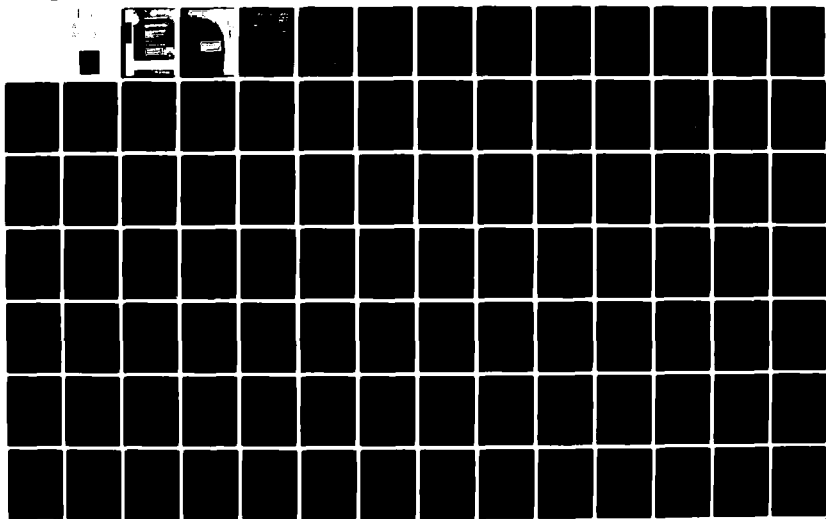

AD A10699



UNCLASSIFIED

Security Classification of This Page When Data Entered

REPORT DOCUMENTATION PAGE		AS INSTRUCTIONS ON THE OPPOSITE PAGE
1. AUTHOR(OR CORP.) NAME(S)		2. REPORT NUMBER
NAVTRAVQUIP 78-C-0182-18		AD-A106 999
3. TITLE(S) AND SUBTITLE(S)		4. AUTHORING OR PERFORMING ORGANIZATION
Prototype Equipment Student Guide for ACE (Air Intercept Controller Prototype Training System).		Final Report. 20 SEP 78 - 20 JUN 81
5. AUTHOR(S)		6. PERFORMING ORGANIZATION NUMBER
Nancy M. Smith, Ronald D. Cranberry, Robin Malley, Diane Berry, Michael H. King, [unclear]		0611-1007
7. AUTHORING OR PERFORMING ORGANIZATION NAME(S) AND ADDRESS(ES)		8. PERFORMING ORGANIZATION REPORT NUMBER
Logicon, Inc., Tactical & Training Systems Div. P.O. Box 00150 San Diego, California 92130		7796-293
9. CONTRACTING ORGANIZATION NAME(S) AND ADDRESS(ES)		10. SECURITY CLASSIFICATION OF THIS REPORT
Naval Training Equipment Center Orlando, Florida 32813		UNCLASSIFIED
11. SECURITY CLASSIFICATION OF THIS REPORT (When Data Entered)		12. SECURITY CLASSIFICATION OF THIS REPORT
UNCLASSIFIED		UNCLASSIFIED
13. STATEMENT OF RESPONSIBILITY FOR THIS REPORT		
Approved for public release; distribution unlimited.		
14. DISTRIBUTION STATEMENT OF THIS REPORT (When Data Entered)		
UNCLASSIFIED		
15. SUBJECT TERMS		
Voice Technology Advisory Group (VTAG) Air Intercept Controller (AIC) Prototype Training System Air Controller Exerciser (ACE) Automated Training Student Manual		
16. ABSTRACT (Continue on reverse side if necessary and identify by block number)		
This document provides an Air Intercept Controller (AIC) trainee with all of the information required to use the Air Controller Exerciser (ACE) training system. Descriptions of the component parts of this experimental prototype training system, and the operating procedures associated with them, are provided. The student objectives and syllabus of the training course offered with ACE are described. The vocabulary elements and system training procedures used with the system's advanced computer speech recognition and generation capabilities are also fully documented.		

421 171

TABLE OF CONTENTS

<u>Section</u>		<u>Page</u>
I	INTRODUCTION . . . . .	3
II	AIC'S JOB . . . . .	6
III	ACE'S PURPOSE . . . . .	7
	Lectures . . . . .	7
	Audiovisual Aids . . . . .	7
	Live Air Control . . . . .	7
IV	ACE STUDENT GUIDE USE . . . . .	8
APPENDIX A	ACE STUDENT GUIDE . . . . .	9

LIST OF TABLES

<u>Table</u>		<u>Page</u>
1	ACE Student Guide Sections . . . . .	4
2	ACE Student Guide Supplements . . . . .	5

Accession For		
NTIS GR&I	<input checked="" type="checkbox"/>	
DTIC TAB		
Unannounced		
Justification		
By		
Distribution/		
Availability Codes		
Avail and/or		
Dist	Special	
<b>A</b>		

SECTION I

INTRODUCTION

The experimental prototype Air Intercept Controller (AIC) Training System or Air Controller Exerciser (ACE) was developed with four basic goals in mind. These goals are to:

- a. Study the usefulness, in military training, of a system which can speak and understand what is said to it.
- b. Provide AIC trainees with the training (using simulation) they need to control live aircraft under an instructor's supervision.
- c. Study how well students learn using a system that can change the instruction a student receives based on his work.
- d. Provide suggestions to the Navy for building and developing a training system for air intercept controllers (AICs) and anti-submarine air controllers (ASACs).

The ACE Student Guide (Appendix A to this report) was developed to assist with the achievement of the second goal. The guide was written with six sections. Table 1 provides a description of the structure of the guide. Table 2 describes the supplements to the guide.

TABLE 1. ACE STUDENT GUIDE SECTIONS

SECTION	TITLE	SUBSECTIONS	CONTENT
I	Introduction		Overview of the guide's parts and how the information they contain can be used during training.
II	Overview and Rationale of the System		What the AIC trainee must learn to do and how the system will provide the training he needs.
III	System User Notes	(A) Instructional Area	The parts of the Student Station and how their controls function.
		(B) Console	
IV	Scoring on Practice Exercises	(A) Practices with Error Freezes	Why error freezes are used, the definition of PMV's and their use in scoring, the methods used in setting exercise standards.
		(B) Practices without Freezes	The uses for these exercises (versus those with error freezes) and the information available after each run of these exercises.
V	Instruction	(A-H) Levels 1 through 8	Detailed diagrams describing the content and ordering of lessons and practice exercises within each level of the course. Statements of what the student must be able to do to pass each level.
VI	System Messages	(A) Tests	The CRT messages and TV presentations given after each test or check response.
		(B) Checks	
		(C) Practice Exercises	The CRT messages shown after each practice run and/or each error on a run.
		(D) Speech Practice	The CRT messages and voice prompts given when the student is (1) practicing a voice call, (2) training the system to recognize a call, (3) checking the system's recognition of a call.
		(E) Speech Collection	
		(F) Speech Validation	

TABLE 2. ACE STUDENT GUIDE SUPPLEMENTS

SUPPLEMENT	NAME	CONTENT
A	AIC's Job Description	Description of the AIC's job and his place in the Air Defense Organization.
B	Reviewable Segments	Instructional segments that may be selected for review by pressing the ABORT key
C	AIC Training Vocabulary	The phrases and parts of phrases used to train the system to understand the student's voice.
D	ABORT Menu	Menus and options that appear when the ABORT key is used.
E	AIC Messages	The voice calls the system's AIC voice is capable of making.
F	Team Member Messages	The CAP, SMC and pseudo-bogey or Maneuvering AIC-craft calls the system can make.

SECTION II

AIC'S JOB

The AIC has a complex job and an important one. He acts as a coordinator in the anti-air warfare tactical situation surrounding his assigned aircraft. He reports pertinent information to the aircrews and to the Ship's Weapons Coordinator. In this way the AIC can offer a constantly updated picture of the tactical anti-air warfare environment to the aircrew, who must live in that situation, and to the decision makers who must command that environment. Although the AIC doesn't really "control" his assigned aircraft, for that is the pilot's job, his instructions and recommendations carry weight. He links the aircrews with those who must determine how an aircraft can best be used in an anti-air warfare situation. The AIC makes sure that those who assign an aircraft to a mission and those who carry out the mission are both acting with full knowledge of the tactical environment. The AIC may not be in "control," but without him, those who do control the situation couldn't do their jobs nearly as well.

Within his job, an AIC performs three basic duties. These duties are:

- a. To relay information about the tactical situation for assigned aircraft to use intercepting threats (enemy aircraft).
- b. To plan setups for assigned aircraft to use in performing mock intercepts for aircrew training.
- c. To assist the Ship's Weapons Coordinator in managing and coordinating aircraft as required by the situation.

All three of these duties require the AIC to perform many smaller tasks. These tasks must be done at the proper time and with accurate results. The AIC must be able to do many of these tasks automatically. This requires the AIC to be very familiar with the equipment he uses on the job. This reduces the need for the AIC to lose his train of thought by looking at the console controls.

A more detailed discussion of the AIC's job and how he fits into the Air Defense Organization is included in Supplement A of Appendix A. The words and phrases he commonly uses (or hears used by others) while doing his job are listed in Supplement B to Appendix A.

SECTION III

ACE'S PURPOSE

The ACE training package was developed to teach only those skills which are a basic part of the AIC's job. It is not meant to replace all of the other types of instruction available through the AIC School. ACE offers training only on the topics of:

- a. equipment operations
- b. general AIC tasks and procedures
- c. bogey intercepts
- d. rendezvous
- e. aircrew training for intercepts.

Additional training available through the AIC School can come in the form of:

- a. lectures
- b. audiovisual aids
- c. live air control.

LECTURES

Lectures given by instructors in the AIC School cover a wide variety of AIC job-related topics. Students who use the ACE system will be given a list of lectures they should attend. These lectures will be on those topics not covered by ACE instruction. They should be considered an important part of the instruction these students receive while assigned to AIC School.

AUDIOVISUAL AIDS

Films, slides and videotapes available through the AIC school can be used by ACE system users. The information presented with these materials can increase the AIC trainee's knowledge about job-related topics. A listing of recommended materials will be given to ACE system users.

LIVE AIR CONTROL

An AIC trainee currently spends two to three of his six weeks in AIC School controlling live aircraft under the guidance of an instructor. To prepare the student for this activity, the ACE training system offers one level of instruction on those skills an AIC needs to plan setups for aircrew intercept training. Practice with simulated aircrew training scenarios of varying levels of difficulty are designed to make it easier for the student to move from the synthetic training offered by ACE to that of live aircraft control.

SECTION IV

ACE STUDENT GUIDE USE

The ACE Student Guide should be carefully reviewed in order to find out:

- a. What skills are needed to be a successful AIC?
- b. What instruction is offered by the ACE training system?
- c. What features does the ACE system provide for student use?
- d. How can the student best use ACE's features to proceed smoothly through the course of study?

Guide users are encouraged to read it thoroughly once and then use it as a reference whenever necessary. Notes in the margins, highlighting marks, and paper clips on selected pages, all can help the user to personalize his copy of the guide and make it more useful.

NAVTRAEQUIPCEN 78-C-0182-10

APPENDIX A

ACE STUDENT GUIDE

NAVTRAEQUIPCEN 78-C-0182-10

ACE STUDENT GUIDE

Preface

This guide is designed to be used by Air Intercept Controller (AIC) trainees who use the Air Controller Exerciser (ACE) training system while enrolled in a Naval AIC School.

TABLE OF CONTENTS

<u>Section</u>		<u>Page</u>
I	INTRODUCTION . . . . .	15-18
II	OVERVIEW AND RATIONALE OF THE SYSTEM . . . . .	19-22
III	SYSTEM USER NOTES . . . . .	23-24
	A. Instructional Area . . . . .	25-36
	B. Console . . . . .	37-46
IV	SCORING ON PRACTICE EXERCISES . . . . .	47-48
	A. Practices with Error Freezes . . . . .	49-52
	B. Practices Without Freezes . . . . .	53-56
V	INSTRUCTION . . . . .	57-64
	A. Level 1 . . . . .	65-70
	B. Level 2 . . . . .	71-76
	C. Level 3 . . . . .	77-84
	D. Level 4 . . . . .	85-90
	E. Level 5 . . . . .	91-94
	F. Level 6 . . . . .	95-100
	G. Level 7 . . . . .	101-108
	H. Level 8 . . . . .	109-118
VI	SYSTEM MESSAGES . . . . .	119-120
	A. Tests . . . . .	121-124
	B. Checks . . . . .	125-126
	C. Practice Exercises . . . . .	127-130
	D. Speech Practice . . . . .	131-136
	E. Speech Collection . . . . .	137-140
	F. Speech Validation . . . . .	141-142
Supplement A	AIC's Job Description . . . . .	143-146
Supplement B	Reviewable Segments . . . . .	147-152
Supplement C	AIC Training Vocabulary . . . . .	153-156
Supplement D	ABORT Menu . . . . .	157-162
Supplement E	AIC Messages . . . . .	163-164
Supplement F	Team Member Messages . . . . .	165-166

ACE STUDENT GUIDE

Introduction (Section I)

**Guide Use** This guide can help you while you are using the ACE training system. This guide can help you to understand:

- how to operate the system
- what the system can and cannot offer you
- what you will learn to do, when, and why
- what you should be able to do, and how well, after receiving instruction on ACE
- how your work will be evaluated.

**Guide Overview** This manual contains six sections, some of which contain several named and numbered subsections. It is recommended that you thoroughly read each section of this guide to further your knowledge about the ACE training program. You are encouraged to personalize this document by making any notes or markings which will help you while you are using this system.

The following chart provides an overview of each section's:

- name and number
- subsections (if any)
- content.

The Table of Contents lists the page numbers for each section and subsection.

**Guide Sections**

No.	Name	Subsections	Content
I	Introduction		- Overview of the guide and its use
II	Overview and Rationale of the System		- AIC's job - Training AICs - System features - Using the system along with other instruction
III	System User Notes	(A) Instructional Area (B) Console	- Controls and their functions (keyed to pictures) - Appropriate time(s) for using system functions - System outputs, their meanings and uses

ACE STUDENT GUIDE  
Introduction (I)

Guide Sections (cont.)

No.	Name	Subsections	Content
IV	Scoring on Practice Exercises	(A) Practices with Error Processes (B) Practices without Processes	<ul style="list-style-type: none"> <li>- How your errors are detected</li> <li>- What happens when you make one error, several errors, repeated errors</li> </ul>
V	Instruction	(A-H) Levels 1 through 8	<ul style="list-style-type: none"> <li>- How the levels of instruction relate to each other</li> <li>- What you will learn to do in each level</li> <li>- How the units, lessons and practice exercises are organized in each level</li> </ul>
VI	System Messages	(A) Tests (B) Checks  (C) Practice Exercises (D) Speech Practice  (E) Speech Collection  (F) Speech Validation	<ul style="list-style-type: none"> <li>- What you will see on the Student Station CRT and/or the TV screen before, during and after tests and checks</li> <li>- What you will see after each practice run is ended</li> <li>- What you will see (on the console CRT) and hear while you are practicing before training the system to recognize you</li> <li>- What you will see (on the console CRT) and hear while you are training the system to recognize you</li> <li>- What you will see on the console CRT while checking to see if the system recognizes you</li> </ul>

ACE STUDENT GUIDE  
Introduction 1

Guide Sections (cont.)

Name	Subsections	Content
Supplements	A) AIC's Job Description	- Detailed discussion (with diagram) of AIC's place in the defense team
	B) AIC's Job Vocabulary	- Words and phrases commonly used on the job by the AIC (CLASSIFIED)*
	C) AIC's Training Vocabulary	- Words and phrases used with the ACE training program
	D) ABORT Key Menus	- What your options are after stopping the instruction
	E) AIC Messages	- What you will hear in demonstrations or as voice prompts
	F) Team Member Messages	- What you will hear the CAP, SMC, pseudo-bogey or MAC say during practice exercises and demonstrations
*Bound in a separate volume.		

## General Format

Throughout this guide you will find that certain format features have been included to make it easier for you to:

- read the text, charts and diagrams
- locate needed information
- relate the contents of sections and subsections to one another.

## Unique Features

The following features are unusual and should be noted now:

- The table of contents lists the first and last pages of a section or major subsection.
- Every page is titled with the name and number of section and/or subsection of which it is a part.
- Related materials are presented in short blocks of text.
- Every block is labeled with a subtitle.

ACE STUDENT GUIDE  
Introduction (I)

Unique Features  
(cont.)

- A line indicates the end of a block of information.
  - Information is presented in the form of a list, chart, table, or graph whenever possible.
-

ACE STUDENT GUIDE

Overview and Rationale of the System (Section II)

AIC's Job

The ACE training system is designed to train Air Intercept Controllers to perform three basic duties:

- give aircrews the information they need to intercept threats
- plan aircrew training setups
- assist the Ship's Weapons Coordinator in managing and coordinating Combat Air Patrols (CAPs) to meet the demands of the situation in which the ship is operating.

Additional information about the AIC's job and how it relates to those of other defense team members is in Supplement A ("AIC's Job Description").

All of these duties must be done quickly and accurately. This requires the AIC to know his duties and equipment well. Many tasks must be done automatically so the AIC doesn't have to stop to think or break his concentration by looking at the console controls.

System  
Features

In order to offer good basic training for AICs, the ACE system includes:

- a realistic training console which looks and acts like an OA-7979(V)10/UYA-4(V) NTDS console
- voices for the:
  - CAP (aircrew)
  - SWC
  - pseudo-bogey (in aircrew training setups)
  - maneuvering aircraft (MAC) aircrew (in rendezvous)
  - AIC (samples of what you should say and when).
- a means of understanding what you say, deciding if what was said was appropriate for the practice situation and answering it with another voice (if necessary)
- practice exercises with radar and NTDS displays and team members' voices. These practice exercises vary in difficulty depending on where you are in the program.
- a CRT with a keyboard where you can receive instruction and put in answers to questions

ACE STUDENT GUIDE

Overview and Rationale of the System (II)

System  
Features  
(cont.)

- a TV screen which presents colored pictures and recorded sound for your information
- a CRT display on the console for presenting reminders for you during practice exercises
- a voice system with microphones and speakers so you can talk to the instructor and he to you.

This system is complex in order to re-create some of the people, situations and equipment you will have to deal with when you become an AIC.

---

Instructional  
Features

In addition to using a complex system to re-create the AIC's working environment, the ACE training program gives you instruction which:

- leads you step-by-step through the skills you need to learn
  - requires that you master a skill before you are asked to learn another one
  - gives you regular review and practice on new as well as old skills
  - allows you to complete the program only when you have shown that you have the minimum skills required to be an AIC.
- 

Instructional  
Flexibility

The ACE system offers you instruction that can change to meet your individual needs. The system can:

- determine what your skill weaknesses are and give you more information and practice to overcome them
  - allow you to skip some parts of the program (if you already have some of the required skills)
  - let you review instruction or practice exercises you have already gone through
  - give you immediate information about how well you did answering questions or performing exercises
  - allow you to stop the instruction
  - permit you to test the system's recognition of what you say and retrain the system when necessary.
-

ACE STUDENT GUIDE

Overview and Rationale of the System (II)

**Additional Instruction**      The ACE training package is designed to teach only those skills judged to be a basic part of the AIC's job. It is not intended to replace all other forms of instruction available to you. Specifically, the training offered by ACE involves:

- equipment operations
- general AIC tasks and procedures
- bogey intercepts
- rendezvous
- aircrew training for intercepts.

**Lectures**      Other less basic topics related to the AIC's job are covered by lectures in the AIC School. You will be given a list of lectures you should attend. The lectures should be part of the instruction you receive while assigned to the AIC School.

**Audio-Visual Aids**      You can use films, slides, and videotapes available through the AIC school. The information contained in these materials can add to your knowledge about AIC job-related topics. A listing of available instructional resources will be given to you. Some of these audio-visual aids will be included in this listing.

**Live Air Control**      AIC trainees currently spend two to three of their six weeks in AIC School controlling live aircraft under the guidance of an instructor. To prepare you for this activity, the ACE training package devotes one level of instruction to those skills an AIC needs to plan setups for aircrew intercept training. Practice with aircrew training exercises of varying levels of difficulty should help you move from the ACE training system to live aircraft control.

**Related Materials**      Instructions on when and how to use the controls on the Student Station keyboard are in Subsection III A ("Instructional Area"). The same information about the console is given in Subsection III B. Complete lists of the CAP, SWC and pseudo-bogey/MAC messages provided by ACE are in Supplement F. The vocabulary you will be using with the ACE system is listed in Supplement C.

ACE STUDENT GUIDE  
System User Notes (Section III)

**Introduction** You will progress through the ACE training program more smoothly if you are familiar with how the system works. Specifically, you need to know:

- What you can do with the system's features
- When you can do this
- How (step-by-step) you can make it happen.

Once you know how to make the training system work for you, you can perform some basic tasks automatically. This allows you to focus most of your attention on the new skill you are trying to master. As you become more familiar with this system, you will become more confident in its use. This increased confidence will help to make this a more pleasant training experience for you.

---

**Level One** Directions about how to use the system are provided in Level 1 of the training program. However, this section of the guide also contains this information, should you need to review it from time to time.

---

**Organization** This section of the guide is divided into two subsections on the basis of the two parts of the Student Station. These are the:

- Instructional Area (Subsection A)
- Console (Subsection B)

Each subsection provides you with information about the controls (and their associated functions) on the equipment being described.

SYSTEM USER NOTES (SECTION III)  
Instructional Area (Subsection A)

**Introduction** The Instructional Area equipment of the Student Station includes (see the illustration below):

- a CRT display and keyboard with special function keys (plus the usual letter, number and symbol keys)
- a color TV monitor
- voice input volume control
- a headset with a microphone and a jack in which to plug the headset.

The following materials describe the location of and functions performed by these pieces of equipment and their controls.

---

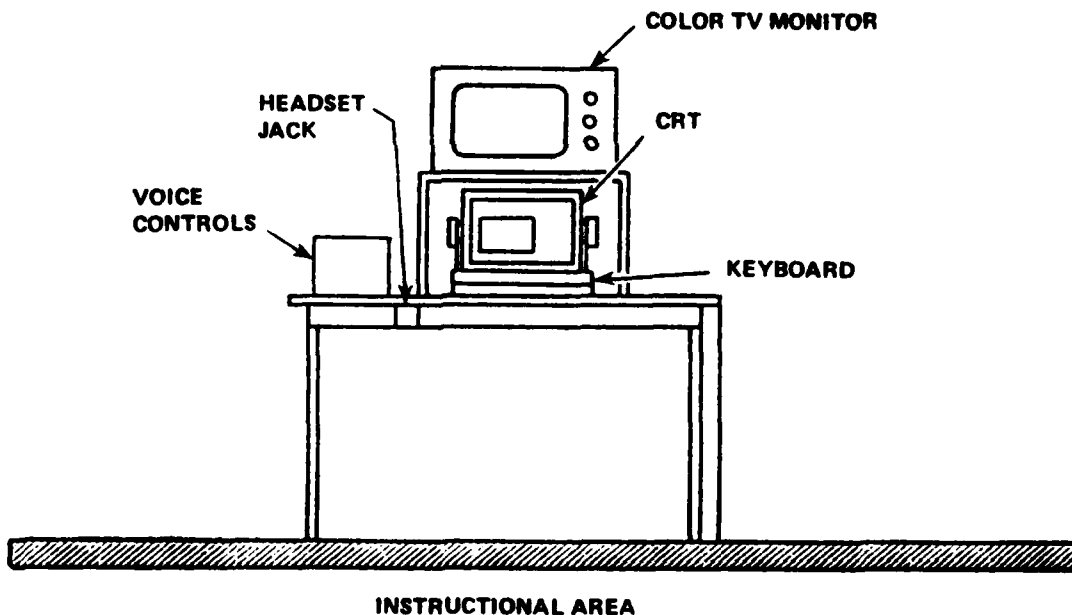

SYSTEM USER NOTES (III)  
Instructional Area (A)

Student Station CRT      The Student Station CRT displays pages of printed instructional material for you to read and study. Explanations of what you will be learning to do, when, and why, will usually appear on this CRT. Test questions and directions on how to answer them will be presented here. Some of the console preparations you need to do before a practice exercise starts will also be shown on this CRT. This Student Station CRT, with the keyboard, offers you a means of entering information into and obtaining information from the ACE system. This CRT generally serves as your "home base", directing you to where you should be (at the Student Station CRT or the Console) and stating what you could (or should) do once you're at that location.

---

Student Station Keyboard      The keyboard for the Student Station CRT is used when you want to:

- sign on the system
- sign off the system
- call the instructor
- test the system's recognition of you saying phrases
- retrain the system on phrases it fails to recognize you saying
- review the transmissions made in your last Practice without Freezes (see Subsection IV A)
- take a break
- re-start the instruction
- answer a test question
- change the picture shown on the TV screen or the words shown on the CRT.

---

Special Function Keys

Unless stated otherwise, all special function keys act in the following way:

- when a key is pressed, the name of the function appears on the CRT
- until "ENTER" (the NEXT/ENTER key) is pressed, the function is not performed by the ACE system
- a blinking cursor follows the last letter in the name of the function until "ENTER" is pressed

SYSTEM USER NOTES (III)  
Instructional Area (A)

Special  
 Function  
 Keys  
 (cont.)

- when you enter a special function that is currently not valid, "INVALID ACTION" appears on the CRT followed by a list of valid special function keys.

When you press one of these keys (and then press the NEXT/ENTER key, as required) you are entering a command into the system. That command causes the system to react in a pre-defined way. Throughout the following discussion of the special functions keys,

- a word in all capital letters and underlined means the key itself
- all capital letters in quotation marks indicates the entering of a command.

The locations of the special function keys are illustrated in the figure below.

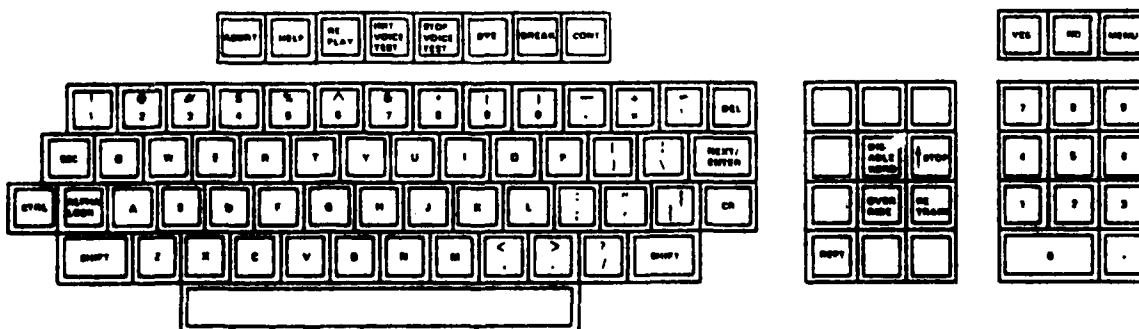

Student Station Keyboard

SYSTEM USER NOTES (III)  
Instructional Area (A)

Special  
 Function  
 Keys (cont.)

The functions of the special function keys are defined as follows:

- ABORT. The function linked to this key stops the running of the segment you are in when the command is entered. After an "ABORT" has been entered, a special ABORT menu will appear, from which you may select the following options: review, continue instruction, sign off, display statistics (see Supplement D, "ABORT Key Menu").

Caution: If you are in a review segment when you press ABORT, you will be returned to the beginning of the instruction you were in when you asked for the review. If you are in a Practice without Freezes because you used your "challenge" option and you enter "ABORT", you will have failed the challenge. Whenever you are in a regularly scheduled lesson or practice when you enter "ABORT", you will be put into the beginning of the instruction you were in when you pressed the ABORT key regardless of where you were before in the lesson or practice.

If you only want to get off the system and you can wait until the end of the lesson or practice you are in, use the BYE key. That way, you will not repeat some instruction needlessly.

If you encounter problems with a lesson or practice exercise and want out to review some instruction on your position in the course, "ABORT" is the correct function to enter (otherwise, use "HELP"). Also, at certain times, you will be told (with a CRT message) that it is an appropriate time to review. Use the ABORT key to do this.

- HELP. This key is used to enter the command to signal the instructor that you need his assistance. A message such as, "Your student has asked for help. Please go to the student station." will appear on the Instructor Station CRT, along with a "beep". It also will cause the instruction or exercise you are in to "freeze". Use the CONT key when you want to continue the instruction.
- REPLAY. This key is used to command ACE to schedule a voice replay to follow after completion of the segment or scenario you are currently in. This replay will be a voice only replay of your most recent Practice without Freezes exercise. It will be possible to "freeze" this replay. (See BREAK.)

## SYSTEM USER NOTES (III)

Instructional Area (A)

Special  
Function  
Keys (cont.)

- INIT VOICE TEST. Entering "INIT VOICE TEST" causes ACE to schedule a special testing of the system's ability to recognize you saying phrases on which the system has been trained. The test will begin after the segment you are currently in has been completed (or you have finished a run of a practice exercise). During the test, the system will echo the phrases you say.
- STOP VOICE TEST. "STOP VOICE TEST" ends the voice test started with "INIT VOICE TEST".
- BYE. This key is used when you want to signal that you wish to sign off the system. When "BYE" is entered, the system begins to search for the next segment end. When you work up to that point in the instruction a message will appear indicating that you have asked to be taken off the system. The system will then automatically sign you off. The sign-on message will appear on the Student Station CRT.
- BREAK. This key is used when you want to freeze the action of the ACE system. It may be used by you or the instructor when it is necessary to force a pause during any segment. The system is unfrozen when "CONT" is entered.
- CONT. This key is used when you want to cancel the action of the BREAK or HELP key. Normal system functions reappear.
- YES/NO. These special function keys cause "YES" and "NO" to appear on the CRT. They are for you to use in answering questions asked by the system (on the CRT).
- MENU. This key causes a list of the currently available special functions to be displayed on the CRT.
- DEL. The DEL key deletes ("erases") an entry you are making if you have not yet pressed the ENTER key. If you change your mind or make an error in an entry, press the DEL key instead of ENTER. Then you can request another function or enter a different response without having caused an error.

The DEL key works without following it with ENTER.

SYSTEM USER NOTES (III)  
Instructional Area (A)

Special  
 Function  
 Keys (cont.)

- NEXT/ENTER. The NEXT/ENTER key has two functions related to it. The "NEXT" function calls up the next page of a sequence of text pages. The "ENTER" function causes the command previously pressed to be sent to the ACE system. Commands do not take effect until the NEXT/ENTER key has been pressed. The action of the NEXT/ENTER key is immediate. "NEXT" does not have to be followed by "ENTER" to work.
- RETRAIN. "RETRAIN" causes a special collection of your voice saying selected phrases. The collection occurs at the end of the lesson (or practice exercise run) in which you are currently working. The collection is for a phrase on which the system has already been trained. You or the instructor select the phrase from the menu. The new collections will replace the previous collections made for the phrase.

Instructor  
 Keys

Two keys on the Student Station keyboard are functional only when the instructor activates them. These keys are:

- DISABLE KBRD. "DISABLE KBRD" deactivates the Instructor key subset on the Student Station keyboard.
- OVERRIDE. This function key allows the instructor to overrule ACE's placement of you within the instruction. An OVERRIDE Menu will appear on the CRT that will contain such options as to advance you to the next scheduled segment, or to take you back to any earlier segment. If an earlier segment is selected, you will return to your former (pre-"OVERRIDE") position in the course after you complete the selected segment. Your activity will be frozen until after the selection of an OVERRIDE Menu option.

SYSTEM USER NOTES (III)  
Instructional Area (A)

Color TV  
 Monitor

A color TV monitor is located above the CRT at the Student Station. The monitor presents pictures and sound stored on a videodisc. The videodisc player is located under the Student Station table. There are no operator controls for this equipment. The ACE system controls what is displayed on the TV screen and when.

Voice Controls

On the Student Station table is the Remote Control Terminal for the Speech Understanding System. Refer to the figure below for the location of the VU meter and the LEVEL ADJ switch that are used during voice training. The LEVEL ADJ switch is used to set your voice level for your transmissions. The setting you select should keep your voice level registering in the upper part of the white area on the meter, with only occasional movements into the red area. The appropriate setting for you should be determined during Level 1. You can then use that setting during the rest of the course.

The control on the right-hand side of the box labeled "Earphone volume" is used to set the volume level on the messages you receive through your headset. You will need to find the level setting which is comfortable for you to use.

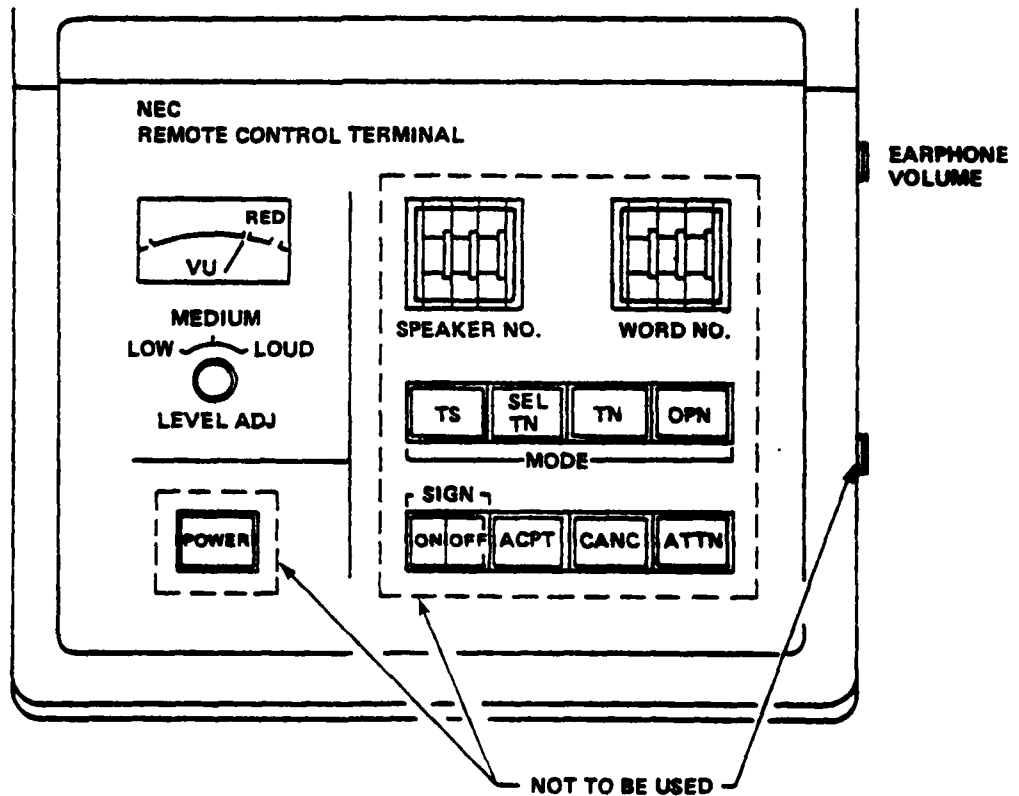

SYSTEM USER NOTES (III)  
Instructional Area (A)

Basic  
Procedures

The following procedures are basic to your proper use of the ACE System. They are listed here for you as a quick reference should you need to review them.

• Sign On:

- a message on the Student Station CRT will tell you to enter your last name (as it was registered on the system)
- type in your last name on the keyboard
- press ENTER once you have checked the name on the screen and found it to be correct (if you find an error, press DEL and re-type the name correctly, then press ENTER). In response to this input, you should see a message saying,

"Hello, <your first name or  
preferred name>!"

You can then proceed with the instruction by pressing NEXT.

If instead a message appears informing you that the disks containing your records is not in the system, inform your instructor. If you have already been registered on the system, your instructor will need to load the disk containing your records into the system. If you have not been registered, the instructor will need to do that at this time.

• Sign Off: There are two methods; one delayed and one immediate.

- Press BYE (delayed) then ENTER. You will be let off the system at the end of the instruction you are currently doing. When you reach the end (after BYE has been pressed), the system will automatically sign you off. The sign-on message will appear on the Student Station CRT.
- Press ABORT (immediate) then ENTER. You will immediately be taken out of what you are doing. A menu of options (including sign off) will appear on the CRT. You should then select that option (see Supplement D).

SYSTEM USER NOTES (III)  
Instructional Area (A)Basic  
Procedures  
(cont.)

Caution: When you get back into the instruction (after using the ABORT key) you are sent back to the beginning of the segment you were working on. You'll have to repeat any part of the segment you had already completed. The better times for using the ABORT key are when you want to call up the ABORT key options that appear on the ABORT menu and use something other than the "sign off" option.

- Take a Break:
  - press the BREAK key
  - press ENTER
- Continue Instruction (after a break):
  - press the CONT key
  - press ENTER
- Proceed (or change a TV picture or page of text):
  - press NEXT
- Call the Instructor:
  - press the HELP key
  - press ENTER
- Start Voice Test: (It is recommended that you regularly check to see that the system is recognizing you saying the phrases you're currently using.)
  - press INIT VOICE TEST key
  - press ENTER
- Stop Voice Test:
  - press the STOP VOICE TEST key
  - press ENTER
- Retrain\*: (It is best to retrain only those phrases or parts of phrases which the system is failing to recognize you saying.)
  - press the RETRAIN key
  - type in the number of the phrase to be retrained
  - press ENTER

---

\*See the "Rules for Good Speech Recognition".

SYSTEM USER NOTES (III)  
Instructional Area (A)

Basic  
Procedures  
(cont.)

- ABORT: (To sign off, review instruction, continue instruction, review your course performance so far.)
    - press the ABORT key
    - press ENTER
    - select the number of the option you want
    - press ENTER
- See Supplement D, "ABORT Key Menus," for more information about the options pressing the ABORT key calls up.
- 

Rules for Good  
Speech  
Recognition

By following the rules listed below, you can improve the system's recognition of your voice calls. This can help make the system's evaluation of your performances on practice exercises more accurate.

- Adjust Microphone Position Carefully. Position it so that:
  - If you pucker your lips they barely brush the microphone
  - and
  - it is slightly off center.
- Speak naturally as though to a person standing two or three feet away. Don't yell, whisper, or try to add unnatural emphasis.
- Choose a good voice input level by speaking the word "five" and setting the voice meter knob on the communications panel in such a way that the needle moves into the upper units of the white area.
- Once a good meter level is found, don't change it!
- Use only the phrases in the vocabulary.
- Speak crisply and quickly.
- Use normal pronunciation!! Use the same pronunciation you will use during operation.
- Do not speak overly clearly (for example, avoid carefully putting the "t" on port...you probably would not do that when you speak during operations and the difference makes it harder for the computer to understand).

SYSTEM USER NOTES (III)  
Instructional Area (A)

Rules for Good  
Speech  
Recognition  
(cont.)

- Conform to these stylization requirements:

- Always pause after the initial aircraft callsign (three dots equal a pause in the CRT prompts)

Example: "Crackerjack...tighten turn."

- Never add pauses. Pause only where indicated in the prompts you see and hear.

- Always pause after a sequence of three digits.

Example: "Stranger 1-6-5...8"

- Try to speak consistently when talking to the system.
  - Use the INIT VOICE TEST key every once in a while to practice. You will find that with just a little practice you can achieve nearly perfect speech recognition.
-

SYSTEM USER NOTES (SECTION III)

Console (Subsection B)

**Introduction** The training console is made to look and function like an OA-7979(V)10/UYA-4(V) NTDS console. (See Page 45 for a discussion of console use.)

**Console Features** The following materials describe the functions of all controls and indicators on the console. The locations of the controls and indicators are shown on the illustration below. (NOTE: All references to "LEDS" mean the small red lights located next to certain switches.)

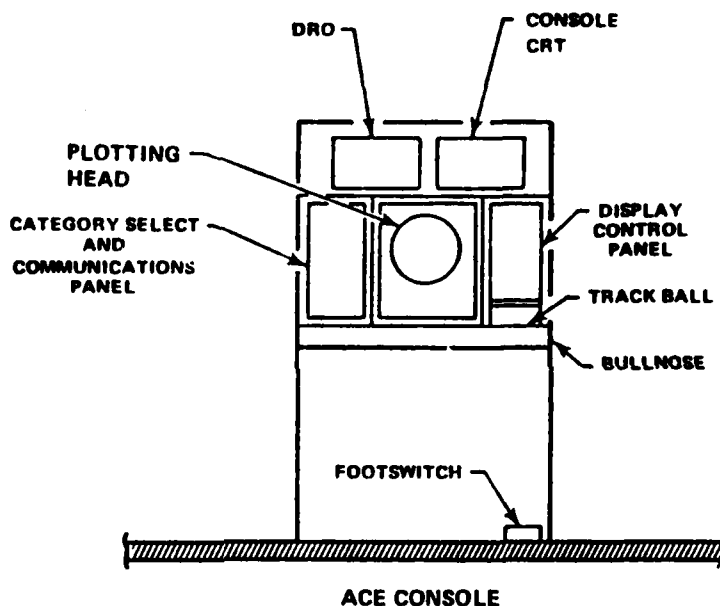

- DRO. The Data Readout is located in the upper left of the console. A black and white CRT is used to display readouts in the same format as on the left hand side of the OA-7979(V)10 NTDS console.
- CONSOLE CRT. This black and white CRT is located in the upper right of the console. It is used to display letters and numbers as instructional reminders for you.
- CATEGORY SELECT AND COMMUNICATIONS PANEL. This panel is located to the left of the PPI. The top section contains the category select switches. The bottom section contains all the communications controls. Refer to the figure on the next page for the location of the controls and indicators described below.

SYSTEM USER NOTES (III)  
 Console (B)

Console  
 Features  
 (cont.)

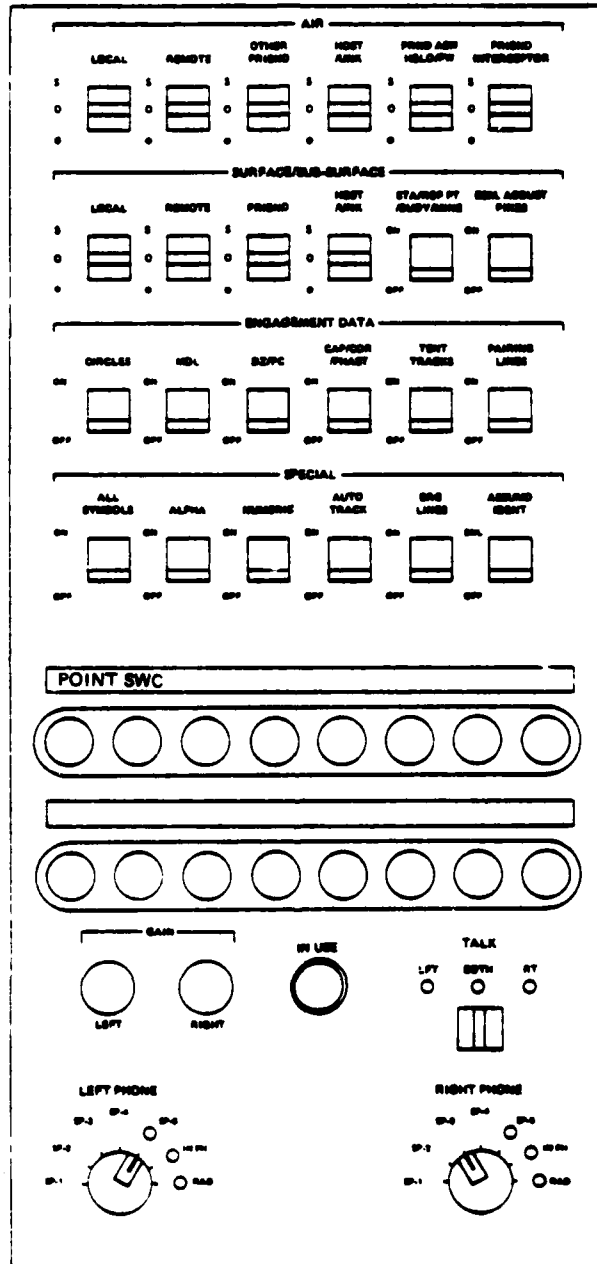

Console Category Select/Communications Panel

## SYSTEM USER NOTES (III)

Console (B)

Console  
Features  
(cont.)

- CATEGORY SELECT AND COMMUNICATIONS PANEL (cont.)
  - POINT switch. This momentary switch causes a pointer symbol to be displayed at the ball tab coordinates for three (3) seconds.
  - SWC switch. This alternate action switch, in conjunction with the TALK and PHONE switches, controls communication with the SWC.
  - TALK switch. This three-position switch, in conjunction with the PHONE switches, determines whether you talk to the SWC or the aircrew(s). The "BOTH" position lets you speak only to the aircrew.
  - LEFT/RIGHT PHONE switches. These seven-position switches determine the audio source for the earphone. INPH (interconsole phone) and RAD (radio) are the active positions.
  - LEFT/RIGHT GAIN. These controls are inoperable.
  - IN USE light. The radio-in-use light is lit when you are using the radio transmitter.
  - LEDS. The LEDs associated with the TALK and PHONE switch positions are used to direct your attention (during the instruction) to switch settings.
- PLOTTING HEAD. The plotting head used on the console is an actual plotting head from an OA-7979(V)10 and is identical in operation. Controls included are panel dim, drop track, enter mode and radar, and the true bearing indicator.
- RADAR DISPLAY. Simulated radar and NTDS symbols are displayed on the monitor located behind the plotting head.
- DISPLAY CONTROL PANEL. This panel is located to the right of the PPI. Look at the following illustration for the location of the controls and indicators described. Inactive controls are FOCUS, ASTIG (astigmatism), N.S./E.W. (centering), SIF/IFF CHALLENGE and GATE (and indicators) and ADJ LEADERS.
  - BRIGHTNESS CONTROLS. These control the brightness of the four types of displays on the PPI.

SYSTEM USER NOTES (III)  
Console (B)

Console  
 Features  
 (cont.)

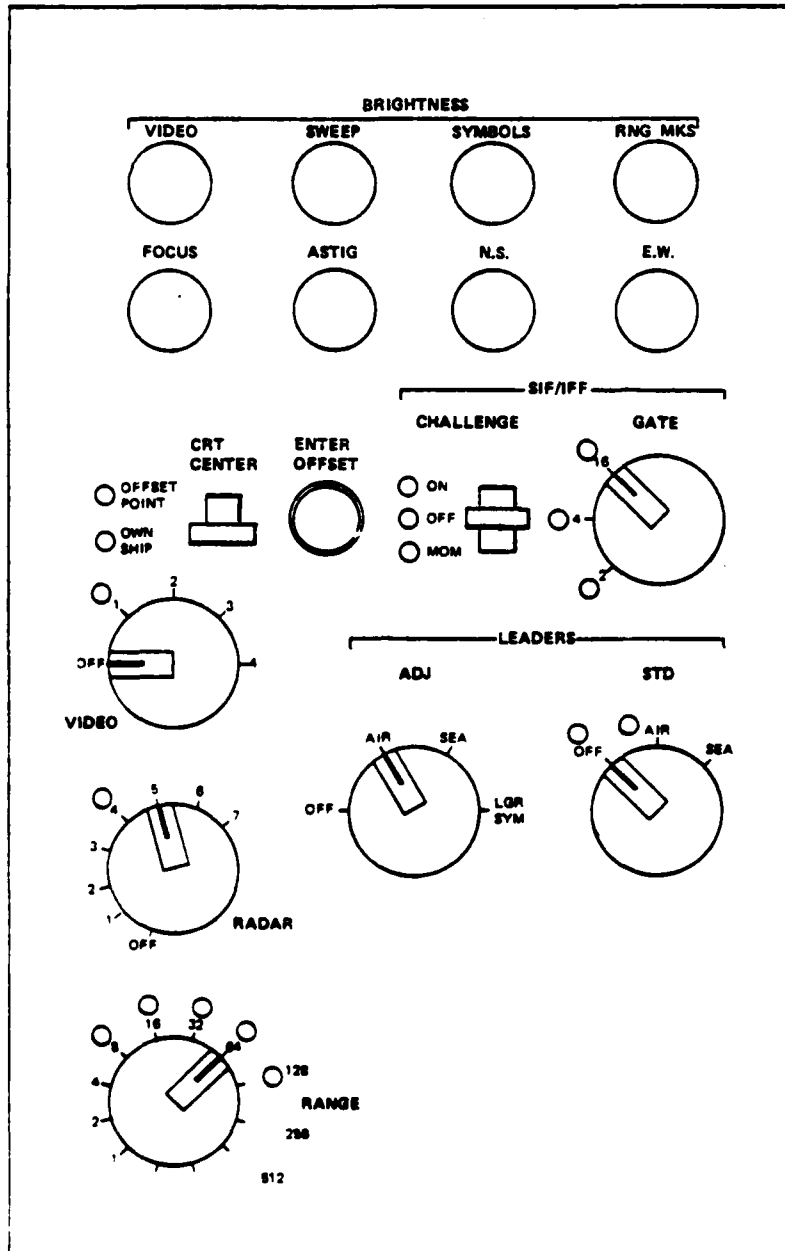

Display Control Panel

SYSTEM USER NOTES (III)

Console (B)

Console  
Features  
(cont.)

• DISPLAY CONTROL PANEL (cont.)

- CRT CENTER. This two-position switch determines what point is displayed at the center of the PPI and operates like the same control on the OA-7979(V)10.
- ENTER OFFSET. This momentary pushbutton switch enters the offset point as the position of the ball tab coordinates.
- VIDEO. This five-position switch is used to select the video desired for the selected radar. Position 1 is the only active position. The other four positions will result in no video being displayed.
- RADAR. This twelve-position switch is used to select the desired radar. Position 4 is the only active position. The other eleven positions will result in no radar display.
- RANGE. This ten-position switch is used to select the radius in miles to be displayed on the PPI. Positions 16, 32, and 64 are the only active positions. Selecting ranges 1, 2, 4 or 8 will result in the 16-mile range being displayed. Selecting ranges 128, 256, or 512 will result in the 64-mile range being displayed.
- STD LEADERS. This three-position switch is used to select standard leaders. The only active position is AIR. Selecting SEA results in no leaders being displayed.
- LEDs. The LEDs associated with the switches shown are used to attract your attention to switch settings during the instruction.

SYSTEM USER NOTES (III)

Console (B)

Console  
Features  
(cont.)

- VARIABLE ACTION BUTTON PANEL. This panel is located at the left side of the bullnose. The figure below shows the location of the controls and indicators. The panel has no mode roller as on the OA-7979(V)10. All mode, alert and VAB labels are fixed in the AC mode. All alert labels and the function labels above each momentary pushbutton switch can be lighted one at a time to attract your attention during instruction.

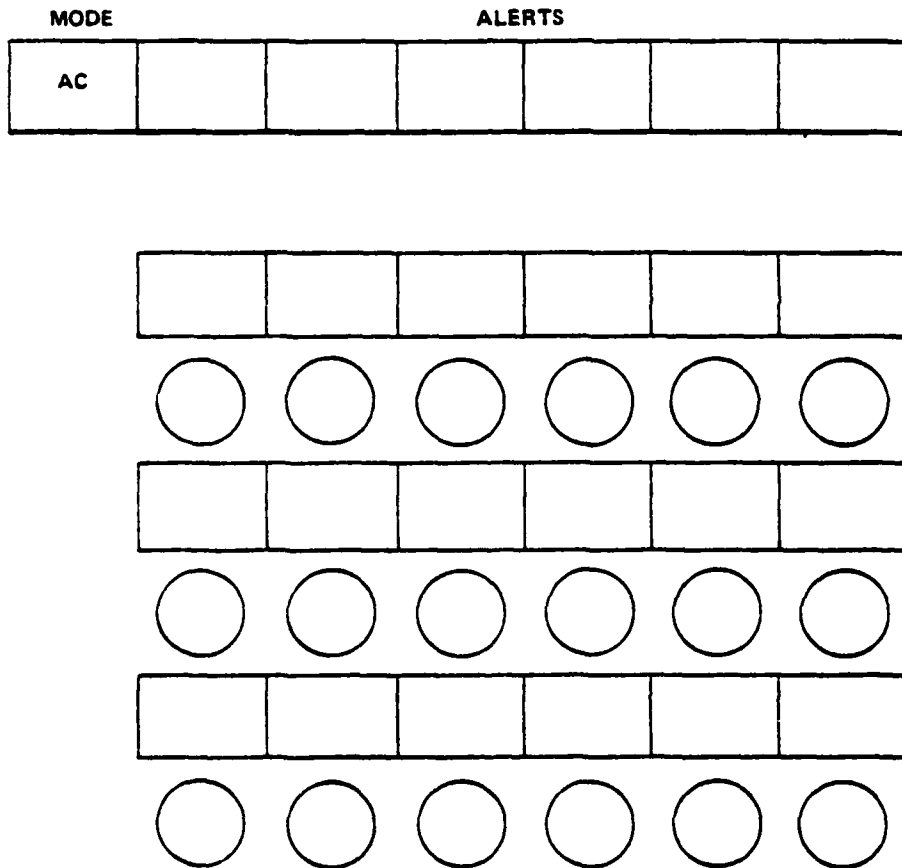

TEC Variable Action Button (VAB) Panel

SYSTEM USER NOTES (III)

Console (B)

Console  
Features  
(cont.)

- TRACK BALL PANEL. The track ball panel is located in a well below the display control panel and works just like the OA-7979(V)10 track ball panel. The picture below shows the location of the controls on this panel. The four momentary action pushbutton switches in the panel perform the same function as those on the OA-7979(V)10.

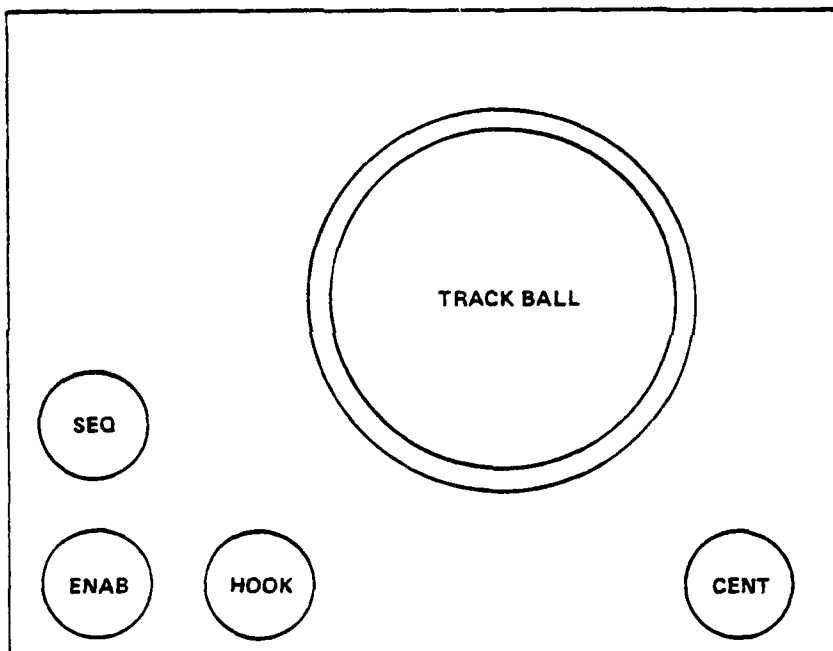

Track Ball Panel

SYSTEM USER NOTES (III)

Console (B)

Console  
Features  
(cont.)

- NUMBER ENTRY PANEL. This panel is located in the center of the bullnose. The illustration below shows the position of the controls and indicators. The panel is identical in operation to the panel in the OA-7979(V)10.

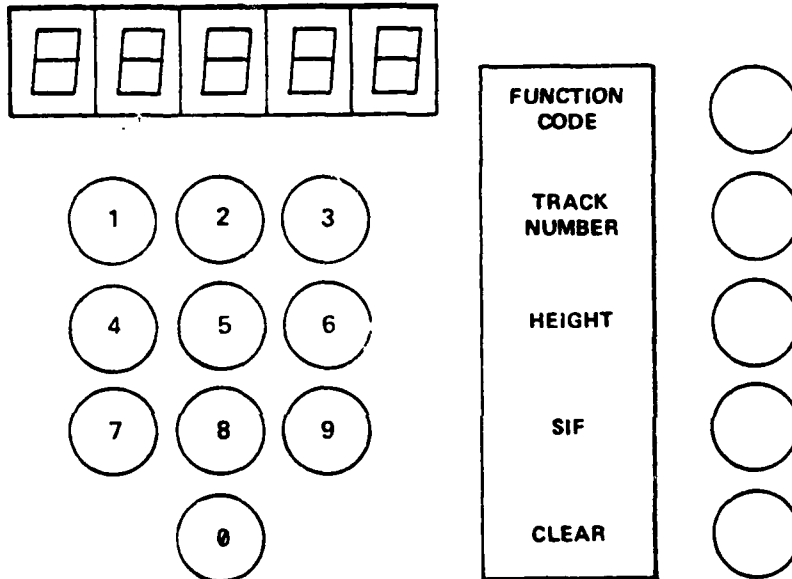

Number Entry Panel

- LOWER FRONT PANEL. The lower front panel under the bullnose houses the main power switch, the panel lighting control, and the communications foot switch.

SYSTEM USER NOTES (III)

Console (B)

Console  
Use

The proper procedures for putting in data and taking it out of the ACE system using this console are explained throughout the ACE training program. The control and indicator descriptions provided in this guide are only designed to explain the functional features that have been built into this console. This console is not designed to function with all of the features of an actual NTDS console. It does, however, offer the features you need for basic AIC training. You will be able to practice using a fully functional console once you enter the "Live Air Control" phase of your training.

---

ACE STUDENT GUIDE

Scoring on Practice Exercises (Section IV)

Introduction This section of the guide explains for you:

- the purposes behind having "Practices with Error Freezes" and "Practices without Freezes" in the ACE course
  - how the system reacts to the correct and incorrect things you do in these practice exercises
  - how your performance on these exercises is scored.
- 

Organization This section is divided into two subsections:

- Practices with Error Freezes (A)
- Practices without Freezes (B)

Each subsection will explain the:

- purpose
  - system responses
  - scoring method for that type of exercise.
- 

Suggested  
Uses

By reviewing the information provided in these two subsections you will have a better understanding of:

- why these exercises are included in the program
  - how your performance on these exercises is scored
  - the way your performance on these exercises affects your progress through the ACE training program.
-

SCORING ON PRACTICE EXERCISES (SECTION IV)  
Practices With Error Freezes (Subsection A)

Introduction In the ACE course, you receive instruction in lessons. These lessons are followed by Practices with Error Freezes. As the name states, whenever you make a critical mistake, that run of the exercise "freezes" (ends). You are then told:

- what errors you made
- how you can avoid repeating those errors.

The exercise then starts over at the beginning and you are given another chance to try and complete the exercise.

---

Scenarios Practices with Error Freezes (and Practices without Freezes) are exercises that use simulation. This simulation allows for:

- radar displays
- NTDS displays
- SWC, CAP, pseudo bogey, and/or MAC voice calls
- your voice calls
- your NTDS inputs

to give you practice in performing the AIC's basic duties. Simulation can vary in difficulty (how many things happen and when) according to what skills you are practicing. The simulation occurs in a somewhat preplanned way. These planned simulations are called scenarios. The scenarios in this course allow you to practice all or part of the things you must do to:

- assist with air intercepts
  - assist with rendezvous
  - plan aircrew training setups
- or
- assist with aircraft emergencies.
-

SCORING ON PRACTICE EXERCISES (IV)  
Practices With Error Freezes (A)

Purpose of Practices

Practices with Error Freezes are designed to:

- provide you with practice on a limited number of newly learned skills
- spot any errors you make on those skills
- suggest the causes and cures for the errors you make.

The focus of any Practice with Error Freezes is limited to new skills. You will receive concentrated practice on these skills. Once you can do them well enough, you will add these new skills to ones you have learned before and practice them together in Practices without Freezes. Practices with Error Freezes help you learn to do new skills well before you must use them along with others.

Scoring Method

In Subsections V A through H of this manual (pages 65-117) you will find statements of "What You'll be Expected to Do" once you have completed the instruction in each level of this course. In order to grade you work on practice exercises, these statements have been rewritten as descriptions the computer can understand. A computer can only understand and react to preplanned inputs. The things you do (that are computer scored) must be kept within certain time and frequency limits. These descriptions do not include all of the:

- things you could do
- things that could happen around you
- time in which you have to respond

that would be "normal" in the real world. These descriptions of what you should do include:

- under what conditions you should do it
- when, how accurately, and/or how often you should do it
- the points (out of a total of 100) which are assigned to certain parts of what you do.

In the ACE course these descriptions are called Performance Measurement Variables (PMVs).

SCORING ON PRACTICE EXERCISES (IV)  
Practices With Error Freezes (A)

Sample  
 PMV

This sample PMV shows:

**TRANSMIT STATION BEARING AND RANGE**

- a. 70 points - Transmit the message "STATION xxx,yy" to the CAP within 36 seconds after the scenario begins. 35 points for response within 48 seconds.
- b. 15 points - Transmitted bearing must be within +/- 15 degrees of correct bearing.
- c. 15 points - Transmitted range must be within +/-2 miles of station.

- THE POINTS ASSIGNED TO THE PARTS OF WHAT YOU DO  
 - - - - - WHAT YOU SHOULD DO  
 - - - - - WHEN YOU SHOULD DO IT  
 - - - - - HOW ACCURATELY YOU SHOULD DO IT

Setting the  
 Limits

When each Practice with Error Freezes was designed for this course, two things were considered:

- what things that the student can do will need to be graded
- which of these graded actions are the most important.

The things that the student would (1) have already learned how to do and (2) would need to do in the simulated situation were selected for grading. Of these, those which would have just been learned were considered the most important.

Mistakes on these skills now cause that run of the exercise to end. Immediately the system explains what mistake(s) have been made to cause the run to end. If you make mistakes on only the other graded skills, you will be told about the errors after the exercise run is completed.

Exercise  
 Standards

For each Practice with Error Freezes there is a set number of:

- freezes (caused by mistakes on one PMV) allowed before you must receive more instruction
- freeze-free runs needed in order to pass the exercise
- failures on non-freezing PMVs that can be made each run before you must receive remediation ("Help" with the review of instruction) on those skills.

SCORING ON PRACTICE EXERCISES (IV)  
Practices With Error Freezes (A)

**System Responses**            If you make too many errors in an exercise run, you will receive help from:

- messages on the console CRT telling you:
  - what mistake(s) you made
  - how to avoid repeating your error(s)
- instruction from the system about your problem areas
- directions from the instructor on how to improve your problem areas.

The instructor can be called by you (HELP key) or the system. The system calls the instructor if you've seen all of the instruction the system can give on a skill, but you are still having problems with it.

---

**System Messages**            Samples of the messages shown in each of these three cases are provided in Subsection VI C of this guide.

---

**Related Materials**           In Subsection V A through H of this guide, you can find out where Practices with Error Freezes occur in the eight levels of this course.

---

SCORING ON PRACTICE EXERCISES (SECTION IV)  
Practices Without Freezes (Subsection B)

Introduction Practices without Freezes are included in the ACF program to allow you to:

- practice skills learned earlier along with those you have learned most recently
  - practice using skills in a realistic simulated situation (with no stopping on errors)
  - receive a grading on your work on the whole exercise at the end of each run.
- 

Course Advancement

Every time you pass a Practice without Freezes, you are allowed to move on to another lesson, unit or level in the course. If you fail a Practice without Freezes, you will receive instruction from the system (or the instructor) until your problem areas are under control and you are able to pass the exercise.

---

Differences Between Practices

Unlike Practices with Error Freezes, these exercises without freezes:

- give you information about your mistakes only at the end of each completed run
- give you practice on most of the skills you have learned up to that point
- allow you to practice without stopping to deal with the error(s) you have made so far in the run
- allow you to "put it all together" by practicing the correct timing of many of the tasks you've learned how to do so far.

In general, Practices without Freezes are more difficult than those with error freezes since you may have to work at doing several tasks, one after another, within a short period of time.

---

SCORING ON PRACTICE EXERCISES (IV)

Practices Without Freezes (B)

Scoring Method    Subsection IV A explains how the descriptions of "What You'll be Expected to Do" are stated in terms the computer can understand (PMVs). The same scoring method is used with Practices without Freezes. However, the things you do which are scored in this type of exercise are chosen on the basis of:

- what you have learned how to do by this time
- which of these things you need to do in this simulated situation
- which of these things have already been graded several times.

The answers to these questions lead to the selection of what skills are (and are not) graded on each Practice without Freezes.

Skills that have been graded in earlier exercises are periodically re-scored in later exercises.

---

Flexible Standards

It is possible to earn 100 points on each PMV used in a practice exercise. However, you are not always required to earn all 100 points on a PMV to pass it in an exercise. How many points you must earn depends on the standards set for that PMV for that exercise. These standards are set according to:

- how important the skill is
- which skills are practiced and scored in an exercise
- how many times the PMV has already been scored in earlier exercises.

Sometimes you will be required to earn the full 100 points on a PMV, especially if you haven't had much practice on that skill. At those times, the points you must earn on other skills may be lowered. This is done when those skills have already been practiced often and/or they may interfere with you doing well on the new skill.

The setting of standards on PMVs is a compromise between always wanting you to do everything perfectly, but still making it possible for you to pass the exercise. Since you aren't a Super AIC (yet), the compromise is necessary.

---

SCORING ON PRACTICE EXERCISES (IV)  
Practices Without Freezes (B)

Setting the  
Limits

On each Practice without Freezes there is a set number of:

- PMVs you can fail per run before you have failed the run
- successfully completed runs you must have in a row before you can pass the exercise.

Before each Practice without Freezes exercise begins, you will be told how many successful runs you must have in a row.

Related  
Materials

---

Subsections V A through H of this guide contain information about where Practices without Freezes occur in each of the eight levels of this course.

---

ACE STUDENT GUIDE  
Instruction (Section V)

**Introduction** This section contains information about the:

- content of this course
- organization of the course's content
- ways in which you will receive information and practice new skills while in this course
- purpose behind using different types of instruction and practice in this course.

**Course Organization (Levels)** The ACE training program is divided into eight levels of instruction. Each level of instruction includes training on a large group of skills related to a broad topic category.

Level	Name
1	System Use/Pretest
2	Basic Skills
3	Basic Intercept
4	Hostile Aircraft Complications
5	Stranger Reports
6	Rendezvous
7	Problems Encountered in Air Intercept Control
8	Training Setups

The following illustration shows the relationship among these levels.

Levels

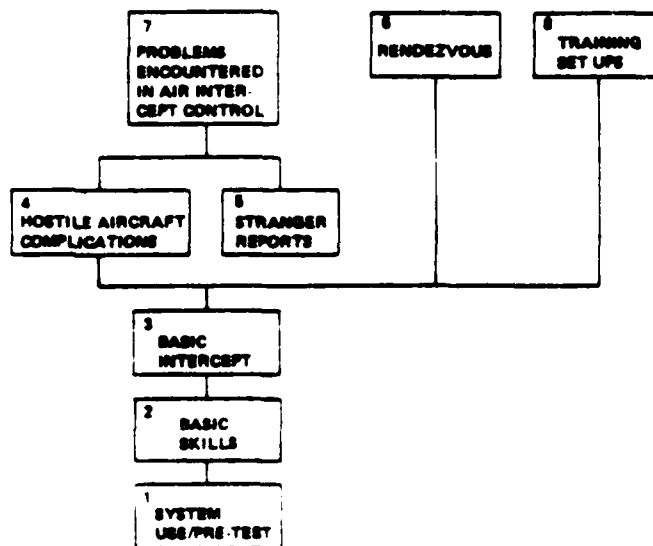

ACE STUDENT GUIDE  
Instruction (V)

**Course Organization (Levels) (cont.)** The instruction in Levels 1, 2, and 3 introduce skills you must have to complete Levels 4, 5, 6, 7 and 8. The skills taught in levels 4 and 5 are used again only in Level 7. Levels 6, 7, and 8 include Practices Without Freezes which are used to make sure that you have mastered all of the skills taught in these and earlier levels.

**Units** Each of the eight levels of the ACE training program is divided into units. Each unit includes a subtopic or group of skills which can easily be learned in a series of lessons.

The unit divisions within each of the eight levels are illustrated with diagrams in Subsections V A-H of this guide.

**Lessons and Exercises** Each unit within a level is further divided into Lessons, Practices with Error Freezes, and Practices Without Freezes. What you do in each of these pieces of the course and how they work together to train you can be reviewed in the following chart.

Name	Definition	Instructional Function
Lesson	Instruction which requires you to (1) read text, look at examples on the TV screen or the console, or (2) to exercise skills and give voice calls in direct response to system prompts. Lessons are where you will encounter new material. Practice on materials is provided through Tests or Checks. Evaluation of level requirements not scored with PMVs* are done through tests or checks.	In a lesson you will be learning memory items, such as tasks, rules procedures, and definitions.  Examples are: <ul style="list-style-type: none"> <li>• definitions of voice calls</li> <li>• rules about what is priority information in a certain situation</li> <li>• the proper procedures for doing a job.</li> </ul>
* See Subsection IV A ("Scoring Practices with Error Freezes")		

Note: The ACE system uses these acronyms: IAT = Lesson; CP = Practice with Error Freezes; FP = Practice without Freezes

ACE STUDENT GUIDE  
Instruction (V)

Lessons and  
Exercises  
(cont.)

Name	Definition	Instructional Function
Practice with Error Freezes	Exercises which provide practice on newly learned skills through the use of scenarios. When you make a critical error, or a certain number of errors of a specific type, the exercise run will stop. The system will provide comments about the errors and make suggestions about ways to correct them.	Practical use of information and skills learned in lessons. Practices use a very controlled but more realistic environment than is offered within Lessons.
Practice Without Freezes	Exercises which permit the realistic use of skills learned earlier. These exercises are different from Practices with Error Freezes because you get no comments about your work until the end of the practice. Also, you may be required to use every skill you have mastered up until then.	Practice of what has been mastered in earlier Lessons, Practices with Error Freezes, or, sometimes, Practices without Freezes.

Lessons

Each Lesson can offer you any or all of the following:

- a demonstration of some skills to be learned
- an opportunity for you to challenge the upcoming instruction (and try to "test out" on some skills)
- review on a skill taught earlier
- instruction on a new skill.

To accomplish this, Lessons can include:

- Demonstrations
- Challenge Options
- Tests
- Checks
- Speech Training

ACE STUDENT GUIDE  
Instruction (V)

Lessons  
(cont.)

- Special Speech Features
- System Feedback.

Each of these lesson components are described in the materials which follow.

---

Demonstrations      Demonstrations are visual presentations (on the TV screen).

These visuals may be accompanied by lines of printed material on a CRT, the system's voices (AIC, SWC, CAP, etc.) or a recorded sound track. These presentations can appear within Lessons or you may call them up to review some things learned earlier in the course. Demonstrations show you how and when to perform the steps involved in doing a task. They may be shown to:

- preview upcoming instruction
  - review instruction just given
  - let you consider whether or not to use the challenge option.
- 

Challenge  
Options

These options are presented within a Lesson. After seeing what skills will be taught in upcoming Lessons, you may want to bypass the regular instructional sequence. If you choose to do this, you are immediately sent to the Practice Without Freezes over these skills. If you want to do so, and your skills are good enough, you could challenge your way through levels 2, 3, 4, 5, and 7. However, if you fail in your challenge (by failing the practice) you are automatically put back into the instruction at the point where the challenge was started. If you succeed on one Practice Without Freezes, but make errors on the bypassed PMVs in a later practice, the system will require you to view some of the instruction you bypassed.

---

Tests

Tests are used within Lessons to provide limited review and practice on information and skills recently shown to you.

ACE STUDENT GUIDE  
Instruction (V)

Tests  
(cont.)

Tests are made up of one or more objective items. These items may be in one of three forms:

- matching
- true-false
- multiple-choice.

Your responses can be in the form of:

- depressing the number key (at the Student Station keyboard) associated with a given answer, or
- manipulating a control on the console.

Tests are designed to give you very limited practice on remembering information or performing a skill that can't be easily measured on the console.

Tests help you to remember certain skills and facts before practicing them in a Practice With Error Freezes.

---

Checks

A Check is a set series of console inputs that you must do within a certain amount of time.

You must perform the specific steps in a certain order. The system, upon receiving the final expected input, checks to determine if all of the steps have been performed. Checks are used whenever a limited practice on a task (versus remembering information) is needed. If the system cannot detect errors on some important steps, a Check is used along with a Test. Like the Test, the Check allows you to practice certain skills before entering a Practice With Error Freezes. Tests and Checks help you to get ready for Practices With Error Freezes just as those exercises prepare you for Practices Without Freezes.

The following chart summarizes how the Tests and Checks of this course relate to the Practices (with and without Error Freezes).

---

ACE STUDENT GUIDE  
Instruction (V)

Practice Exercises

Exercise:

Function:

Practice Without Freezes

A successful performance on this type of practice allows you to pass from one segment or unit to another or from one level to another. Your progress through the ACE program is dependent upon successful performances on Practices Without Freezes.

Practice With Error Freezes

The scope of this type of exercise is limited to intensive practice on specific skills. Once these skills are being performed to a satisfactory level, you will be scored on these and other skills in a Practice Without Freezes.

Check

Checks are used whenever a limited practice on a procedure (versus only remembering information) is needed. If the system cannot spot errors on some important skills, a Check is used in combination with a Test. Like the Test, the Check allows you to rehearse certain skills before entering a Practice with Error Freezes.

Test

Designed to give a very limited practice on remembering information or performing a skill that can't be measured on the console.

Tests help you to remember certain skills and facts before practicing them in a Practice with Error Freezes exercise.

Reviewable Segments

Whenever you complete a Practice Without Freezes exercise, you may wish to review it. The same may also be true with some of the demonstrations shown on the Student Station CRT and TV Screen. To review such segments, you will need to exercise your ABORT option (see ABORT key, page 28) and then select the Review option on the ABORT Menu. A series of Review Menus will then be presented. You can select the segment you wish to see from one of these menus. A complete listing of these Menus is provided in Supplement B of this manual.

ACE STUDENT GUIDE  
Instruction (V)

Speech  
 Training

During Lessons you may be asked to:

- practice making new calls (Speech Practice)
- give the system a chance to collect the information it needs to recognize your voice (Speech Collection)
- check to see that the system recognizes you saying the new transmission (Speech Validation).

This training for you and the system can happen when:

- you decide to use your challenge option, or
- you need instruction on a new call.

Special  
 Speech  
 Features

You or the instructor can:

- retrain the system on a selected phrase (using the RETRAIN Key)
- test the system's ability to recognize you saying a selected phrase (using INIT VOICE TEST).

This retraining or testing of the system can be started between:

- lessons
- segments called up for review
- runs of a Practice with or without Freezes.

The selection of what call (or part of a call) to retrain or test is described in Supplement C. This supplement also contains a listing of the AIC Training Vocabulary. The "Rules for Good Speech Recognition" are listed in Subsection III A. Demonstrations on how to use the system's speech recognition features are reviewable (Review Menu #1). These are:

	<u>Option #</u>		<u>Option #</u>
● Training the computer	1	● Speech Validation	4
● Speech Practice	2	● Voice Test	5
● Speech collection	3	● Retrain	6

See Supplement B for the complete list of reviewable segments. To review any of these demonstrations, you must press the ABORT Key (see page 28) and select the Review option from the ABORT Menu. The option number of the demonstration you want to see can then be selected from one of the Review Menus which will be presented.

ACE STUDENT GUIDE  
Instruction (V)

System  
 Feedback

As you work through the lessons and practices of the ACE training program, you will receive responses from the system in the form of:

- messages from the system's voice (See Section II and Supplements E and F)
- TV screen presentations
- menus on the Student Station CRT
- messages on the Student Station CRT plus review of earlier instruction
- flashing lights, buzzers, beeps and/or console displays (see Subsection III B).

Detailed information about what to expect can be found in the previously noted parts of the guide, plus Subsections VI A through F.

Special Job  
 Aids

In some of the lessons in this course, you will be required to use a:

- widget
  - grease pencil
  - eraser rag
- to complete a task.

The widget (shown at right) will be given to you when you begin Level 6. The widget will be explained briefly in Level 2 and more fully in Levels 6-8.

The widget is a clear plastic measuring device designed to help you:

- plan rendezvous
- track aircraft during NTDS failure (with and without radar)
- plan aircrew training setups.

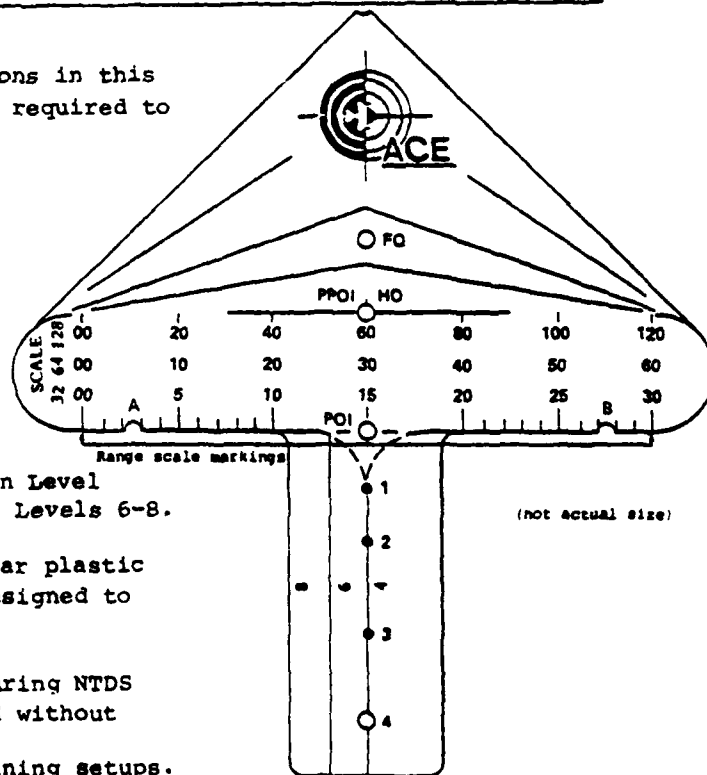

INSTRUCTION (SECTION V)  
Level 1 (Subsection A)

Introduction      Level 1 introduces you to:

- the system's features and controls
- the organization of the course
- the speech capabilities of the system.

This level also includes the Pretest. This test is designed to measure what skills you have before starting this course. If you don't pass all or part of the Pretest, you will have to receive instruction from the instructor on your skill weaknesses. Then you will have to try again to pass the test. Only those who can pass the Pretest are allowed to start this course.

---

Importance

The information you receive in this level about how to operate this system is important to you progressing smoothly through this course. This is especially true when your work is being scored later in practice exercises. The more you know about how to:

- put information into the system, and
- call up the information you need

the easier it will be for you to score well on these exercises. In addition, operating this console in simulated situations prepares you for the use of an actual NTDS console in assisting with live aircraft intercepts. Good console operation skills developed early in this course will carry over into other AIC School activities as well as the duties of your future job.

---

Subsection  
 Uses

This subsection provides you with information about this level's

- content, and
- organization.

By reading it, you will obtain an overview of:

- what instruction and practice you will receive (and when)
- what you'll be expected to be able to do upon completing this level

NAVTRAEQUIPCEN 78-C-0182-10

INSTRUCTION (V)

Level 1 (A)

Subsection  
Uses  
(cont.)

- how well you must perform the required skills in order to pass the Pretest and to advance to level 2.

Level  
Organization

Level 1 is divided into four units. These are illustrated below:

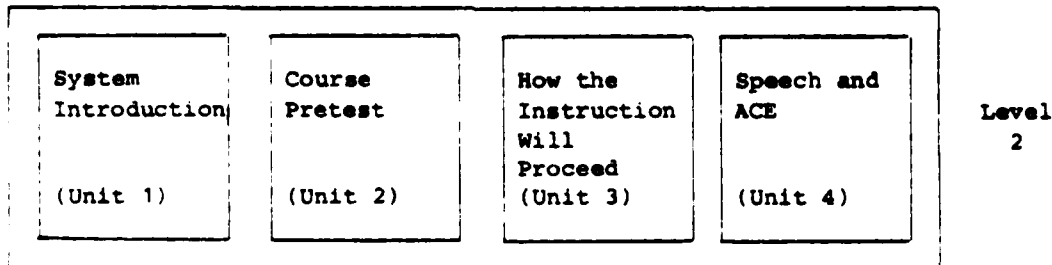

Enter Level 1

Unit  
Organization

The following charts show the organization of the divisions within units 1 to 4 of Level 1. The requirements for passing the Pretest are stated as "What You'll be Expected to Do", listed with Unit 2. The requirements to advance to Level 2 are listed in Unit 4.

Unit 1

(No Challenge Option)

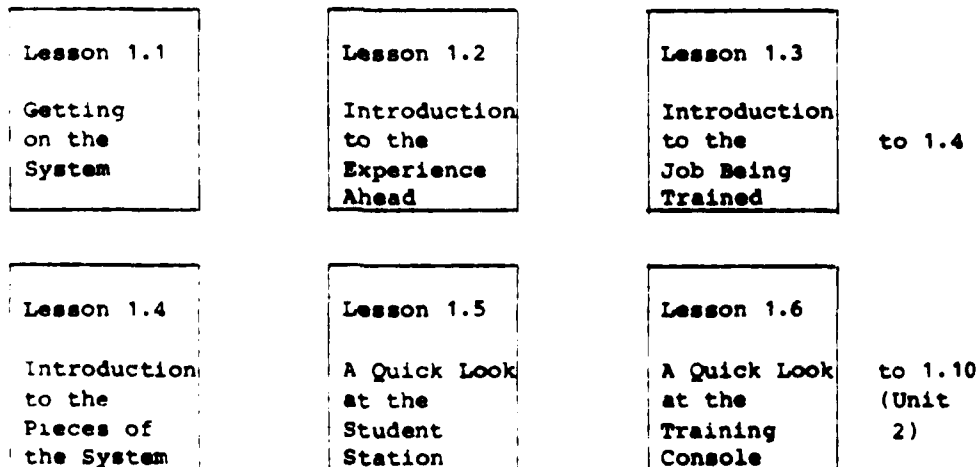

INSTRUCTION (V)  
Level 1 (A)

Unit 2

"What You'll be Expected to Do":  
(To pass the Pretest)

- Select (from a list of choices) the functions and components of the Naval Tactical Data System.
- Match NTDS-related terms to their definitions.
- Match the terms relative, magnetic, and true bearing to their definitions and examples of their correct use.
- Identify the three parts of an R/T message.
- Select (from a list of choices) the duties of the SWC.
- Match DRO Alert names to their definitions.
- Match the NTDS symbols to their definitions.
- Using an operational AC mode NTDS training console:
  - press the VAB or FAB being defined.
  - enter a CAP symbol (within 2 minutes).
- Using an operational AC mode NTDS console with a CAP symbol in the system:
  - change the CAP's heading within 30 seconds.
  - change the CAP's speed within 30 seconds.
  - change the CAP's altitude within 30 seconds.
  - change the CAP's fuel on board within 45 seconds.
- Using an operational AC mode NTDS training console with a CAP symbol and a hostile aircraft in the system:
  - display the geometry between the CAP and the hostile within 2 minutes.
  - accept the geometry displayed between the CAP and the hostile within 30 seconds.
- Using an operational AC mode NTDS training console with ownship and a reference point in the system, find the range and bearing from ownship to the reference point within 1 minute.

INSTRUCTION (V)  
Level 1 (A)

Unit 2 (cont.)

- Using the NEDs of an operational AC mode NTDS training console (with symbols in the system) and a track number, locate the correct symbol within 30 seconds.
- Using an operational AC mode NTDS training console, set up the inter-comm within 1 minute.

(No Challenge Option)

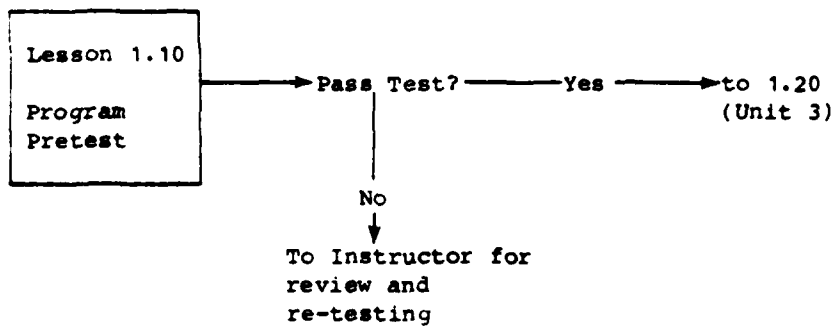

Unit 3

(No Challenge Option)

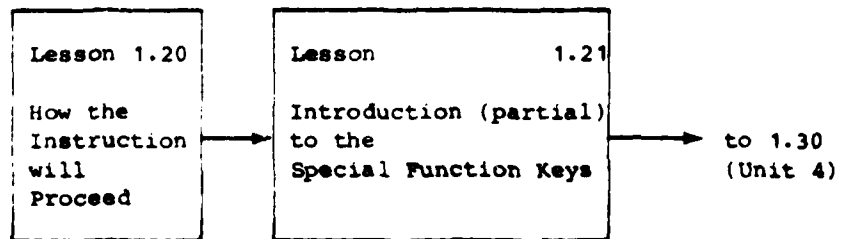

INSTRUCTION (V)  
Level 1 (A)

Unit 4

"What You'll be Expected to Do":

- Using the training console:
  - correctly set the Communication switches
  - correctly set the Control Panel switches.

(No Challenge Option)

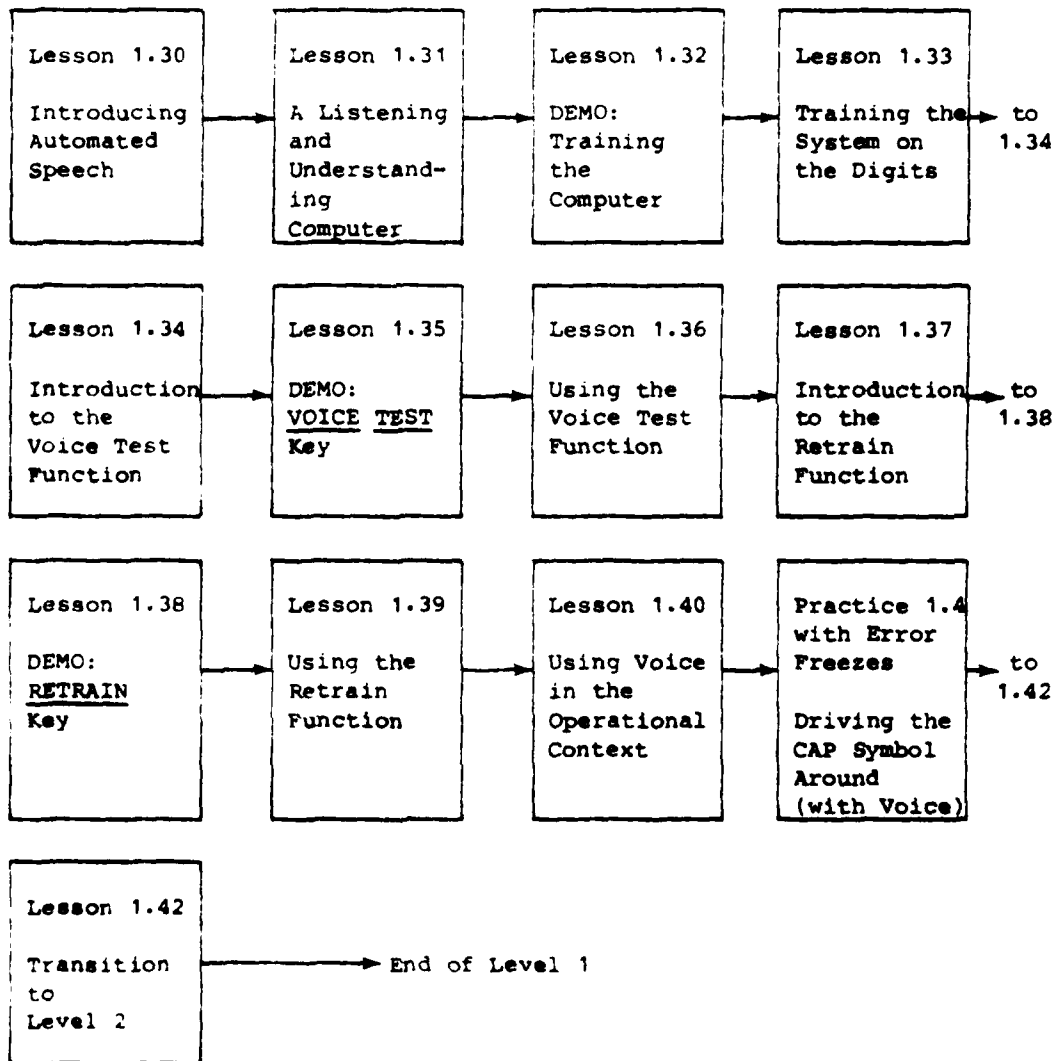

INSTRUCTION (SECTION V)  
Level 2 (Subsection B)

Introduction      Level 2 is designed to teach you to:

- track the CAP
  - give the CAP heading and bearing and range to station
  - engage the CAP to the bogey
  - give the CAP heading and bearing and range to intercept the bogey.
- 

Importance

This level gives you the instruction and practice you need to do these tasks automatically. You will need to use these basic skills regularly in this and most of the upcoming levels of this training program. Naturally these skills are basic to the AIC's job in the real world. While the tasks may not be new to you, you will need to learn how to do them without stopping to think about how or when to do them. After you are able to do these jobs automatically, you will be ready to learn how to perform more of the duties required by the AIC's job.

---

Suggested  
Uses

This subsection provides you with information about this level's:

- content, and
- organization.

By reviewing this material you will see:

- what instruction and practice you will receive (and when)
  - what you'll be required to do to complete this level
  - how well you must perform the required skills in order to advance to Level 3.
-

INSTRUCTION (V)  
Level 2 (B)

Level  
 Organization

Level 2 is divided into two units. These are illustrated below:

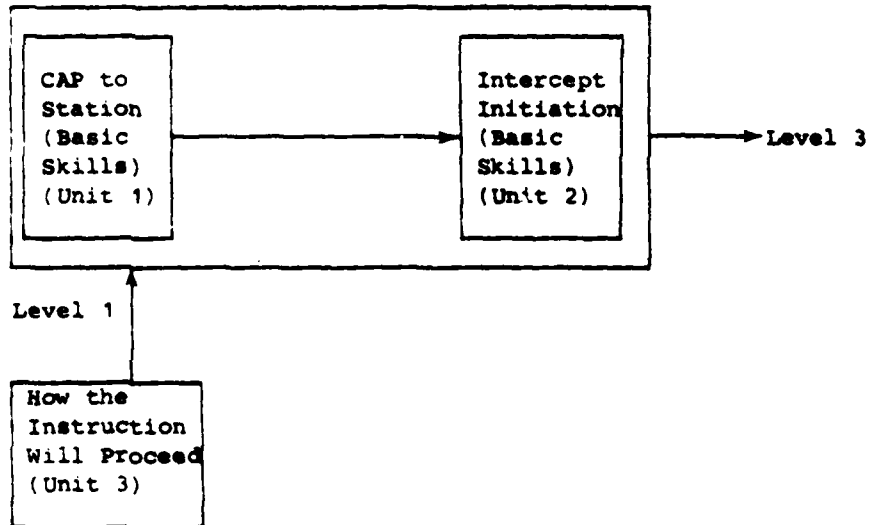

Units

The following pages show the:

- new things you must be able to do (per unit) to pass this level (stated as "What You'll be Expected to Do")
- organization of the divisions within Units 1 and 2.

"What You'll be Expected to Do":

- MAINTAIN CAP SYMBOL IN VICINITY OF CAP VIDEO
  - Keep the CAP symbol to within 1/8 inch of the video 3 out of each 5 times the video is displayed, missing no more than 2 video displays in a row.
- ENGAGE CAP TO STATION
  - Engage the CAP symbol to the CAP station before it is within 5 miles of the station.
  - Give the CAP the heading to station within 24 seconds after check-in, if the aircraft's heading is not within 20 degrees (+ or -) of the station heading (within 20 degrees the call is optional).

INSTRUCTION (V)  
Level 2 (B)

"What You'll be Expected to Do" (cont.):

- ENGAGE CAP TO STATION (cont.)
  - Transmitted heading is within 10 degrees (+ or -) of the correct heading.
- TRANSMIT STATION BEARING AND RANGE (Initial Call)
  - Give the CAP the station bearing and range within 42 seconds of the start of the practice.
  - Transmitted bearing must be with +/- 15 degrees of correct bearing.
  - Transmitted range must be within +/- 2 miles of station.
- TRANSMIT BEARING AND RANGE OF STATION (Continued Calls)
  - Call bearing and range to station within 12 seconds after the sweep passes the CAP, 3 out of 5 sweeps, not missing a call 2 sweeps in a row. Calls should be made until the CAP arrives on station or a stranger call is made.
  - The bearing called must be within 2 degrees (+ or -) of that displayed by NTDS.
  - The range called must be within 2 miles (+ or -) of that displayed by NTDS.
- ENGAGE CAP TO BOGEY
  - Depress the ORD SEND VAB to engage the CAP to the bogey within 9 seconds after the SWC sends a Target Assigned alert.
- VECTOR CAP TO BOGEY
  - Give the CAP the heading to intercept the bogey within 16 seconds of engaging the CAP to the bogey.
  - Heading called must be within 10 degrees (+ or -) of the correct heading.

NAVTRAEQUIPCEN 78-C-0182-10

INSTRUCTION (V)  
Level 2 (B)

"What You'll be Expected to Do" (cont.):

- TRANSMIT INITIAL BOGEY BEARING AND RANGE
    - Give the CAP the bogey's bearing and range within 8 seconds of calling the heading for intercept.
    - The bearing called must be within 2 degrees (+ or -) of that displayed by NTDS.
    - The range called must be within 2 miles (+ or -) of that displayed by NTDS.
  - TRANSMIT INITIAL BOGEY TRACK AND GROUND SPEED
    - Call bogey track and ground speed to the CAP within 18 seconds of initial bogey bearing and range call.
    - Transmitted track must be within 10 degrees (+ or -) of the correct track.
    - Transmitted speed must be within 0.2 mach (+ or -) of the correct speed.
  - TRANSMIT CONTINUING BOGEY BEARING AND RANGE
    - Call the bogey's bearing and range within 12 seconds after the sweep passes the bogey, 3 out of 5 sweeps, not missing 2 sweeps in a row.
    - Transmitted bearing must be within 2 degrees (+ or -) of that displayed by NTDS.
    - Transmitted range must be within 2 miles (+ or -) of that displayed by NTDS.
-

INSTRUCTION (V)  
Level 2 (B)

Unit 1

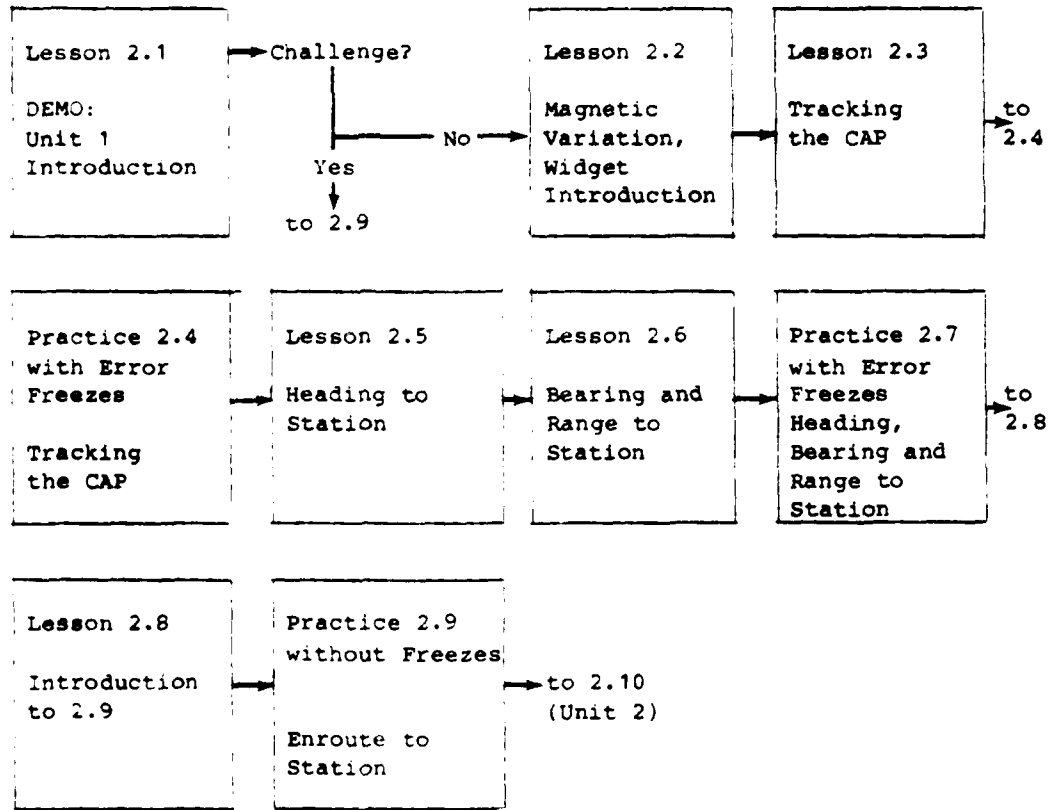

INSTRUCTION (V)

Level 2 (B)

Unit 2

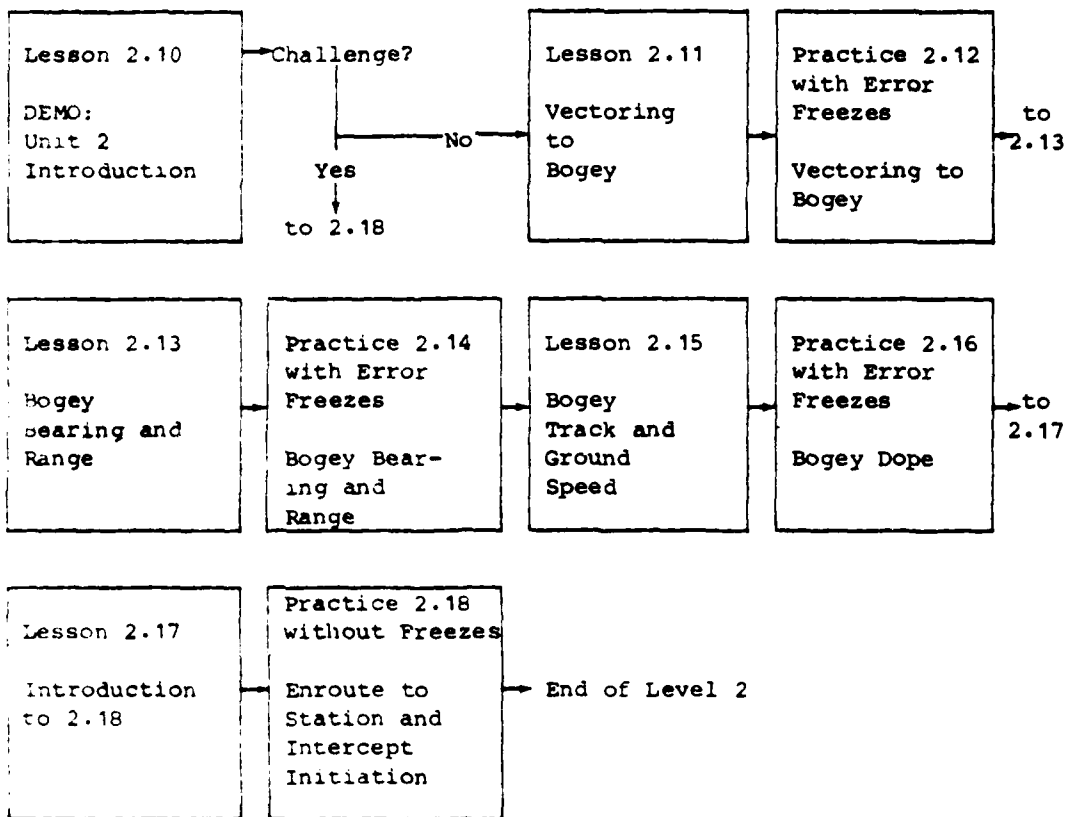

INSTRUCTION (SECTION V)  
Level 3 (Subsection C)

Introduction      Level 3 introduces you to:

- the phases of an intercept mission
- the AIC's jobs in each intercept phase
- incorporating the basic skills with intercept tasks.

---

Importance      Once you can handle the jobs an AIC performs while assisting with a basic bogey interception, you'll be ready to learn how to deal with the complications introduced in later levels. Level 3 gives you the "big picture" of what happens during an intercept from console set up to breakaway after the intercept.

The skills you learn in Level 3 will be used, to some degree, in Levels 4 through 8 of this program.

---

Subsection  
Uses

This subsection explains the:

- content, and
- organization

of this level. Read these materials so that you will know:

- what instruction and practice you will receive (and when)
  - what new things you'll be required to do to complete this level
  - how well you must perform the required skills in order to advance to Level 4.
-

INSTRUCTION (V)  
Level 3 (C)

Level Organization            Level 3 is divided into three units. These are illustrated below:

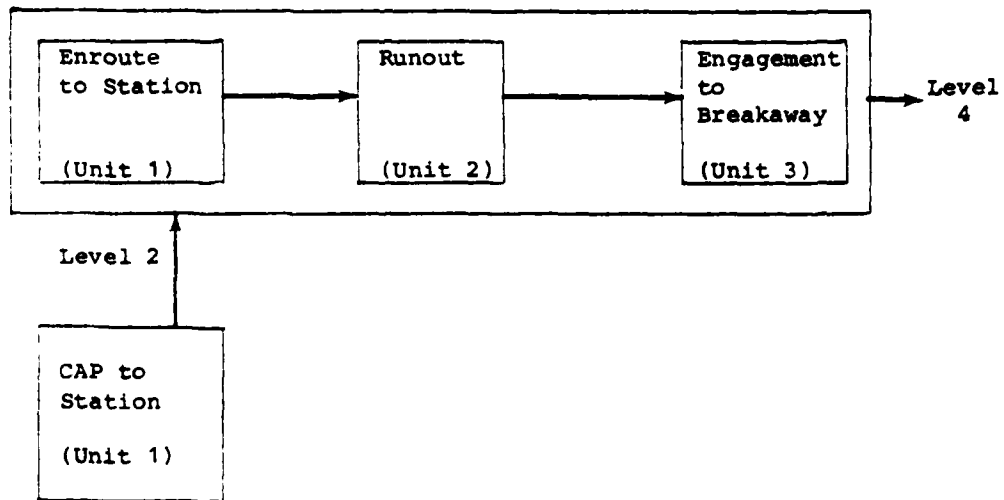

Units

The following pages show the:

- new things you must be able to do (per unit) to pass Level 3. (See "What You'll be Expected to Do")
- organization of the division within Units 1 to 3 of this level.

"What You'll be Expected to Do":

(Unit 1)

- RANGE SCALE AND OFFSET
  - Set the range scale to 32 miles before the offset is entered.
  - Enter the offset within 60 seconds from the start of the exercise.
  - The range to the PPI center from the new ownship position is between 20 and 32 miles at the time the offset is entered.

INSTRUCTION (V)  
Level 3 (C)

"What You'll be Expected to Do" (cont.):

(Unit 1)  
 (cont.)

- RANGE SCALE AND OFFSET (cont.)
  - The bearing of the new PPI center is 20 degrees (+ or -) from the reciprocal of the CAP station's original bearing.
- ENTER CAP SYMBOL, PIF, AND STATION ALTITUDE
  - The CAP symbol is entered at the time the scenario starts.
  - The PIF entered is correct.
  - The CAP altitude entered matches the CAP station altitude.
- "CALLSIGN AIRBORNE FOR CONTROL"
  - Respond to the SWC "CALLSIGN AIRBORNE FOR CONTROL" message within 10 seconds with "ROGER".
- "RUTH, THIS IS c/s . . . ."
  - Respond to CAP check-in message within 10 seconds with "ROGER".
- UPDATE CAP SYMBOL
  - Update the CAP symbol within 12 seconds, after receiving the message "RUTH THIS IS (CALLSIGN) ON TACAN STATION (bearing/range) ANGELS ##, HEADING ###" from the CAP.
  - CAP symbol placed within 1/8" of CAP video.
- ASK CAP FOR STATE
  - Transmit the request for CAP state to the CAP before it arrives on station or within 1 minute of SWC request for the state.
  - Respond to CAP state report with "ROGER STATE ###" within 15 seconds.
- UPDATE NTDS WITH CAP STATE
  - Update CAP state inventory within 75 seconds after each state report from aircrew.

NAVTRAEQUIPCEN 78-C-0182-10

INSTRUCTION (V)

Level 3 (C)

"What You'll be Expected to Do" (cont.):

(Unit 1)  
(cont.)

- NOTIFY SWC OF CONTROL
    - Notify the SWC of having taken control of the CAP after receiving the state report from the CAP and before the CAP reaches station.
    - Respond to SWC "THANK YOU" message with the CAP's state report within 12 seconds.
    - Reported state must agree with state message from the CAP.
  - "ON STATION"
    - Notify the CAP it has arrived on station within 36 seconds after the CAP gets within 5 miles of the station.
- 

(Unit 2)

- TRANSMIT BOGEY COMPOSITION AND ALTITUDE
  - Transmit the bogey's composition and altitude within 12 seconds of the bearing and range call.
  - Transmitted altitude must be the correct altitude.
  - Transmitted composition must be correct.
- PLACE BOGEY ON SEQUENCE LIST
  - Bogey placed on the sequence list within 12 seconds of giving initial bogey bearing and range call.
- RESPOND TO "JUDY" OR "TALLY HO"
  - Do not transmit any bogey data (groundspeed, track, etc.) after the message "TALLY HO" or "JUDY" is received until "LOST CONTACT" or "BREAKAWAY" call is received.
- LOST CONTACT
  - Respond to the message "LOST CONTACT" by transmitting the bearing and range to the bogey, starting within 5 seconds of the Lost Contact message.

INSTRUCTION (V)  
Level 3 (C)

"What You'll be Expected to Do" (cont.):

(Unit 2)  
 (cont.)

- CONTACT
  - Respond to the message "CONTACT (bearing and range)" within 10 seconds with either: "ROGER, YOUR BOGEY TRACKING xxx" or "NEGATIVE, BOGEY (bearing and range)".
  - Respond to the message "CONTACT ###, ###" with the correct call.
  - Respond with accurate track or bearing and range data:
    - If tracking data, within +/- 10 degrees of correct track. If bearing and range data:
      - bearing must be within 2 degrees (+ or -) of that displayed on NTDS.
      - range must be within 2 miles (+ or -) of that displayed on NTDS.

(Unit 3)

- 
- DISENGAGE CAP FROM BOGEY AT BREAKAWAY
    - Disengage the CAP from bogey within 15 seconds after the pilot transmits the "TALLY HO, FOX 1 BREAKAWAY" message.
  - RE-ENGAGE CAP TO STATION AFTER BREAKAWAY
    - Engage the CAP to the CAP station within 12 seconds after disengaging the CAP from the bogey.
  - VECTOR CAP TO STATION AFTER BREAKAWAY
    - Transmit the heading to CAP station within 18 seconds after engaging the CAP to the CAP station.
    - The transmitted turn bearing direction (PORT/STARBOARD) is such that a minimum change in heading is required to come to the correct new heading.
    - The transmitted heading must be within 10 degrees (+ or -) of the correct heading.

NAVTRAEQUIPCEN 78-C-0182-10

INSTRUCTION (V)  
Level 3 (C)

"What You'll be Expected to Do" (cont.):

(Unit 3)  
(cont.)

• REPORT RESULTS OF ENGAGEMENT

- Transmit the message "CALLSIGN BREAKING AWAY" to the SWC within 30 seconds after the CAP reports the results of the engagement.
  - Transmit the engagement results to the SWC within 3 seconds from the time the CAP reports the results of the engagement.
  - The messages must agree with the results as transmitted by the CAP.
-

INSTRUCTION (V)  
Level 3 (C)

Unit 1

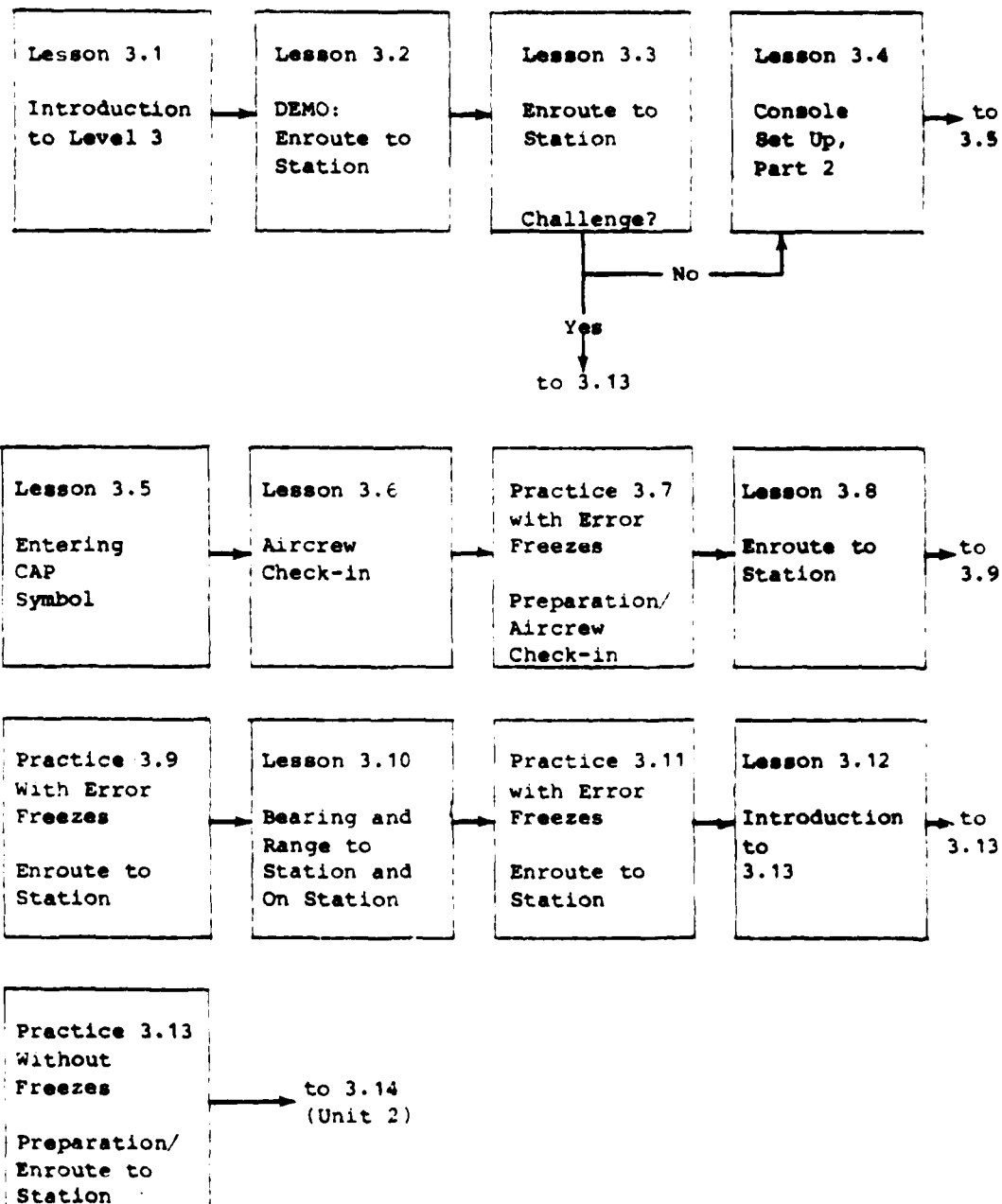

INSTRUCTION (V)  
Level 3 (C)

Unit 2

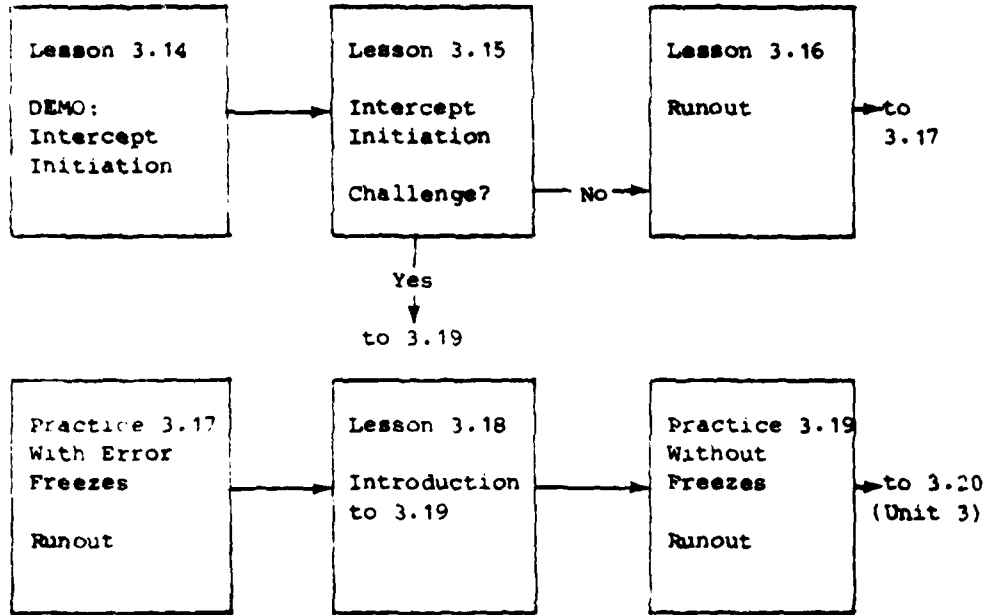

Unit 3

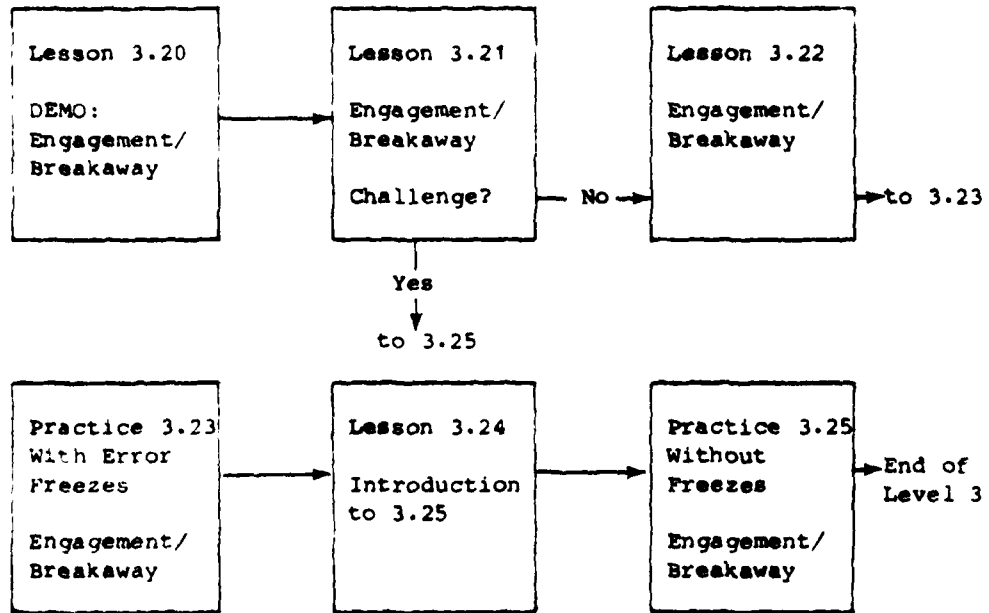

INSTRUCTION (SECTION V)  
Level 4 (Subsection D)

Introduction      Level 4 introduces you to the intercept complications of

- bogey jinks (heading changes)

- bogey splits (missiles).

In this level you will learn how to:

- detect bogey jinks and splits

- report jinks and splits to the CAP

- recommend CAP maneuvers to counter jinks and intercept splits.
- 

Importance

The skills involved in detecting and dealing with bogey jinks and splits are ones you need to develop to be an effective AIC.

These are real problems you will encounter when assisting CAPs with intercepts in the tactical environment. It is important that you learn how to handle them while still managing all of your other intercept related duties.

The skills you learn in Level 4 will need to be blended in with those you gained in Levels 2 and 3. The practice exercises in this level will help you to do this.

---

Subsection  
Uses

This subsection explains the:

- content, and

- organization

of this level. Read these materials so that you will know:

- what instruction and practice you will receive (and when)

- what you'll be required to do to complete this level

- how well you must perform the required skills in order to advance to Level 5.
-

INSTRUCTION (V)  
Level 4 (I)

Level Organization Level 4 is divided into three units. These are illustrated in the following figure:

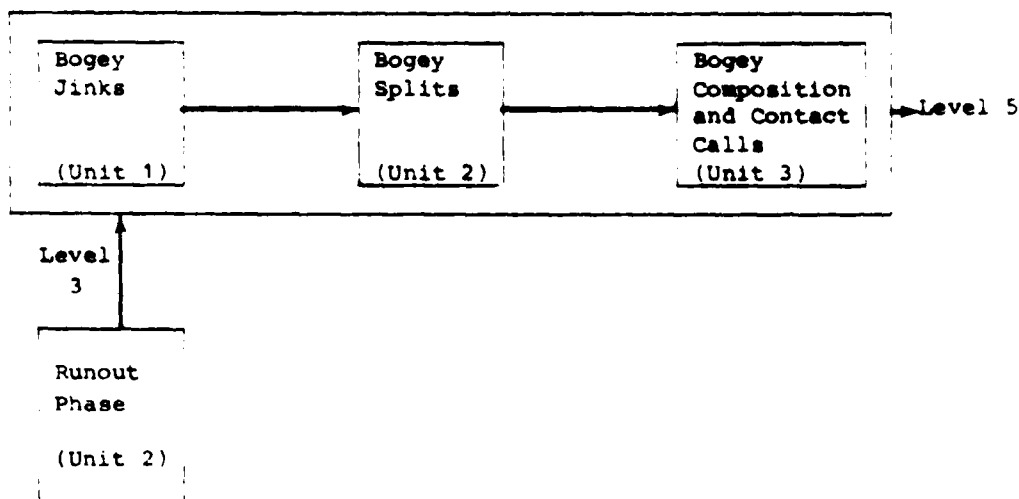

Units

The following pages show the:

- new things must be able to do to pass Level 4
- organization of the divisions within Units 1 to 3 of this level.

"What You'll be Expected to Do"

(Unit 1)

- TRANSMIT "JINK" CALL
  - Transmit the message "BOGEY JINKING (LEFT/RIGHT)" within 24 seconds of the start of the jink.
  - The transmitted direction (LEFT/RIGHT) must be in the correct jink direction.
  - At the time the jink is started, no previous jink transmission (BOGEY JINKING LEFT/RIGHT) should have been made.
- TRANSMIT VECTOR TO COUNTER JINK
  - Transmit the message "CALLSIGN port/starboard xxx" to counter the jink within 36 seconds of jink initiation.

INSTRUCTION (V)  
Level 4 (D)

"What You'll be Expected to Do" (cont.):

- (Unit 1)
- Transmitted revised heading is such that a minimum change of heading is required to come to the correct new heading
  - The new transmitted heading must be within +/- 15 degrees of the correct new heading.
- TRANSMIT UPDATED BOGEY TRACK
    - Transmit the updated bogey track to the CAP within 1 minute after the jink starts.
    - Transmitted new track must be within 15 degrees (+ or -) of correct track.
- 

- (Unit 2)
- TRANSMIT "BOGEY SPLITTING"
    - Notify the CAP that the bogey has split within 24 seconds after the bogey starts a split.
    - Disengage the bogey and engage the new bogey track within 24 seconds after the bogey splits.
  - TRANSMIT NEW BOGEY COMPOSITIONS, ALTITUDE
    - Transmit the new bogey composition and altitude within 12 seconds after the new bogey is engaged.
    - Bogey altitude transmitted must be the correct altitude, as displayed by NTDS.
  - DISENGAGE CAP FROM SPLIT AT BREAKAWAY
    - Disengage the CAP from the split by hitting BRK/CANTCO within 6 seconds of sequencing to the SWC Break Engage alert DRO.
  - DISENGAGE CAP FROM BOGEY AFTER BREAK ENGAGE ALERT
    - After the Break Engagement alert occurs, depress BRK/CANTCO so as to break the CAP's engagement to the bogey within 12 seconds.
  - ENGAGE CAP TO SPLIT
    - After the Engage Track alert is received, depress ORD SND to engage the CAP to the split within 12 seconds.

INSTRUCTION (V)

Level 4 (D)

"What You'll be Expected to Do" (cont.):

(Unit 2)  
(cont.)

- VECTOR CAP TO SPLIT
  - Transmit the heading for the bogey split to the CAP within 12 seconds of sequencing to the SWC Engage alert DRO.
  - Transmit an accurate vector for bogey to the CAP. The heading must be within 10 degrees (+ or -) of the correct heading.
- TRANSMIT INITIAL SPLIT BEARING AND RANGE
  - Transmit the bogey split bearing and range to the CAP within 12 seconds of vector for split message.
  - Transmitted bearing must be within 2 degrees (+ or -) of NTDS displayed data.
  - Transmitted range must be within 2 miles (+ or -) of NTDS displayed data.
- TRANSMIT CONTINUING SPLIT BEARING AND RANGE
  - Transmit the bogey split bearing and range within 12 seconds after the sweep passes the split position. The call must be made 2 out of 3 times, not missing any 2 sweeps in a row.
  - Transmitted bearing must be within 2 degrees (+ or -) of the NTDS displayed data.
  - Transmitted range must be within 2 miles (+ or -) of the NTDS displayed data.

(Unit 3)

- 
- TRANSMIT BOGEY COMPOSITION AND ALTITUDE
    - Transmit the bogey's composition and altitude within 12 seconds of the bogey bearing and range call.
    - Transmitted altitude must be the correct altitude.
    - Transmitted composition must be correct.  
(Focus on multiple bogeys.)
-

INSTRUCTION (V)  
Level 4 (D)

Unit 1

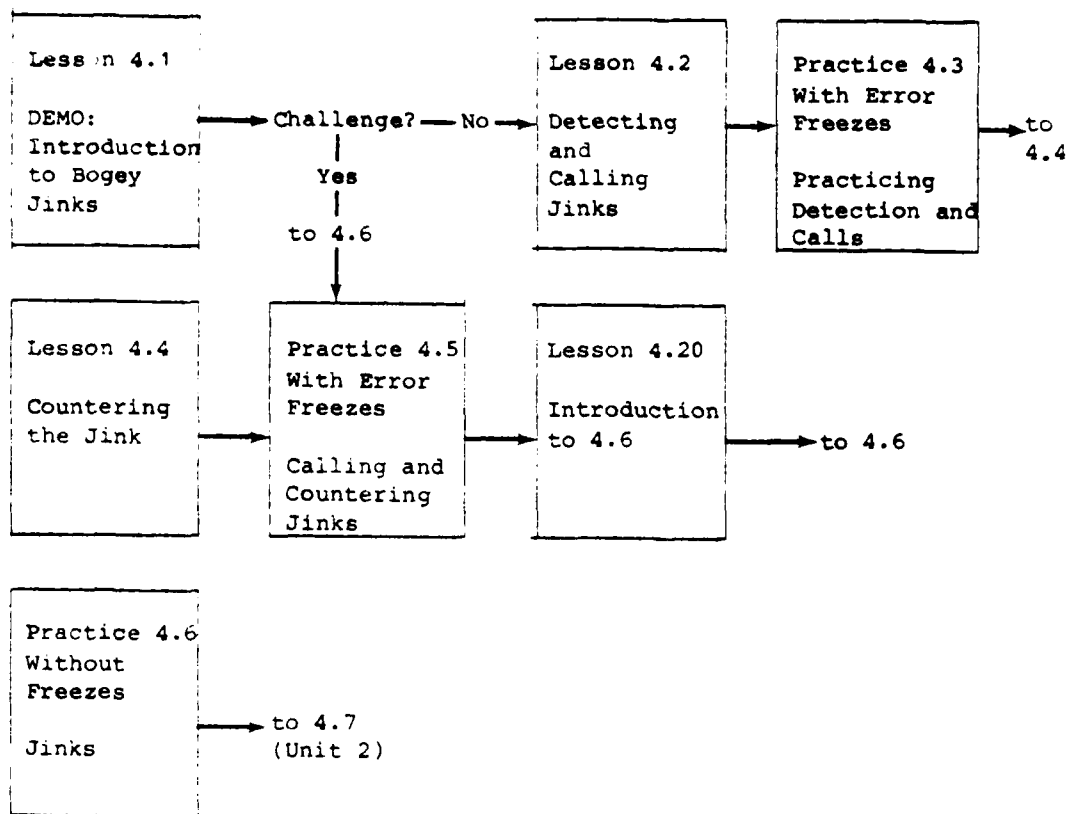

INSTRUCTION (V)

Level 4 (D)

Unit 2

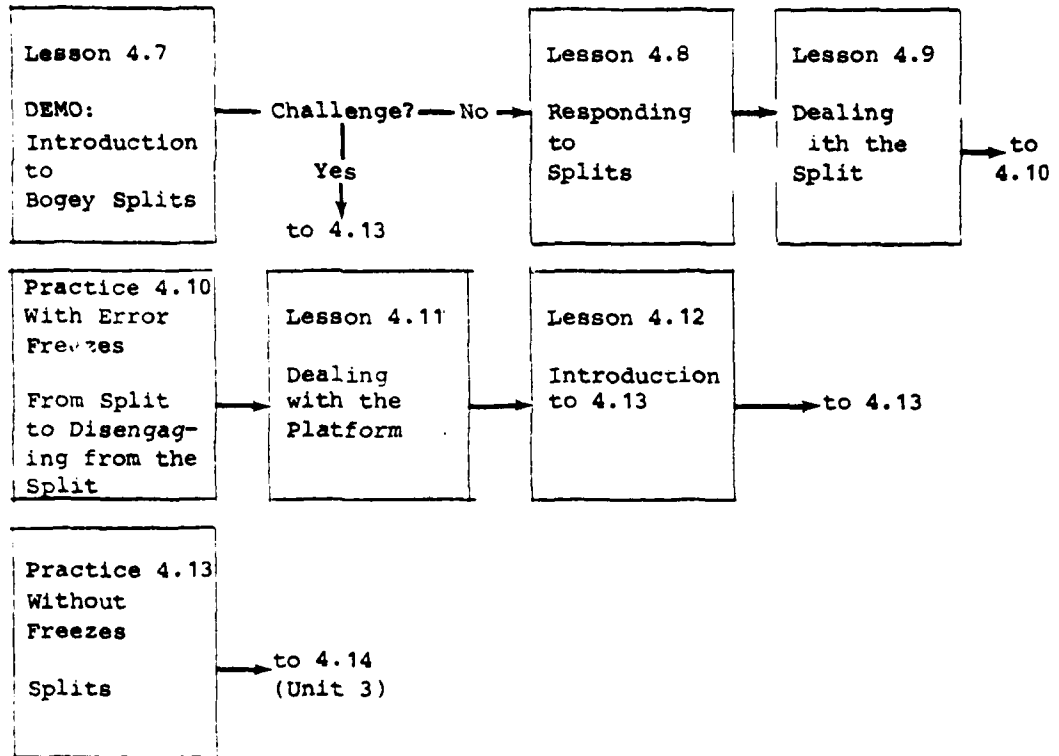

Unit 3

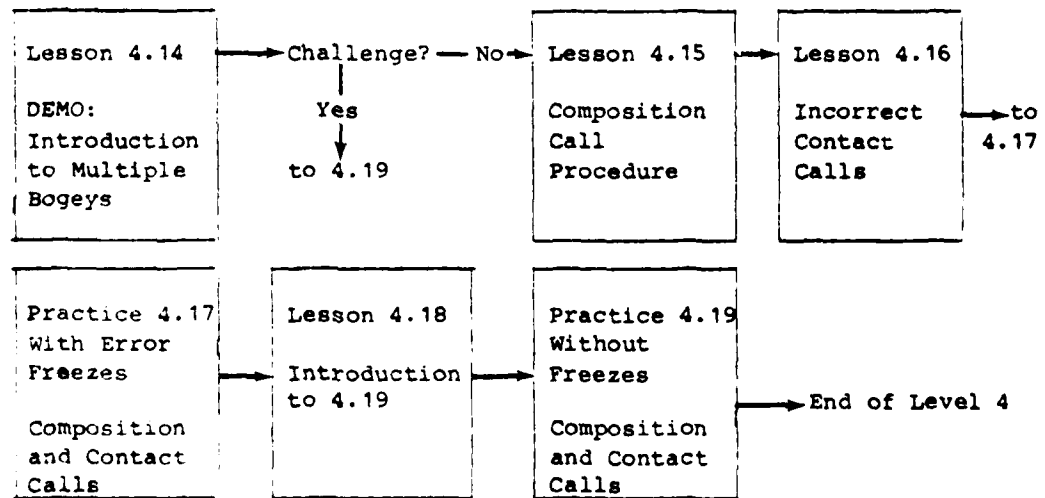

INSTRUCTION (SECTION V)  
Level 5 (Subsection E)

Introduction      Level 5 introduces you to the pre-intercept complication of strangers. In this level you will learn how to:

- determine if a stranger needs to be reported
  - notify the CAP of a stranger's presence
  - report the stranger's track and altitude (angels)
  - notify the CAP when the stranger moves away from the CAP.
- 

Importance      Strangers (friendly aircraft with an unknown call sign) often complicate intercept missions. They can:

- be mistaken for the bogey by the CAP (and be fired at)
- distract the CAP
- collide with the CAP and/or the bogey.

Since none of these possible situations are desirable, and the tactical air environment can become quite crowded, you need to be able to detect and report troublesome strangers to the CAP. Level 5 will give you the instruction and practice you need to learn these new skills and use them along with the ones you learned in earlier levels.

---

Subsection      This subsection explains the:  
Uses

- content, and
  - organization
- of this level. Read these materials so that you will know:
- what instruction and practice you will receive (and when)
  - what you'll be required to do to complete this level
  - how well you must perform the required skills in order to advance to Level 6.
-

INSTRUCTION (V)  
Level 5 (E)

Level                    Level 5 has only one unit.    The instruction you received  
 Organization           earlier that relates to this unit is shown in the following  
                                  illustration:

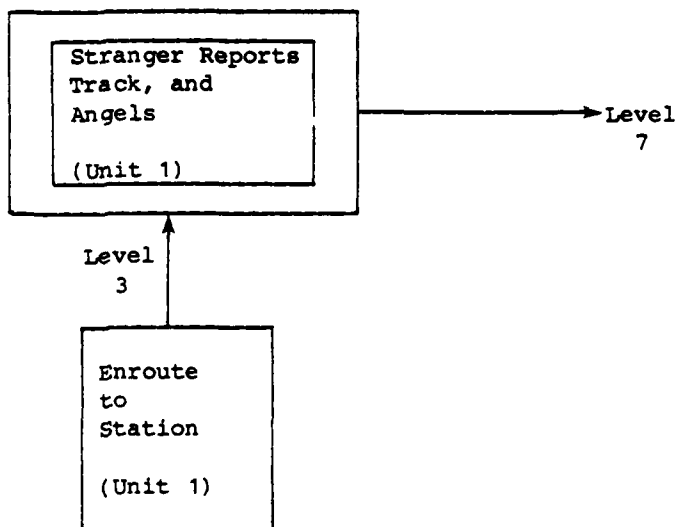

Units

The following pages show the:

- new things you must be able to do to pass Level 5
- organization of the divisions within the unit of this level.

"What You'll be Expected to Do"

(Unit 1)

- DETECT AND REPORT STRANGERS
  - Notify the CAP of the stranger's bearing and range after the stranger closes within 10 miles of the CAP and prior to closing within 5 miles of the CAP.
  - Bearing must be within 10 degrees (+ or -) of correct bearing.
  - Range must be within 2 miles (+ or -) of correct range.

INSTRUCTION (V)  
Level 5 (E)

"What You'll be Expected to Do" (cont.):

(Unit 1)  
(cont.)

- CALL STRANGER BEARING AND RANGE
    - Transmit, to CAP, the stranger's bearing and range 3 out of 5 sweeps missing no more than 2 sweeps in a row, following initial report until either a "VISUAL" call is received from the CAP or until the stranger range increases for 2 consecutive sweeps.
    - Bearing must be within 10 degrees (+ or -) of correct bearing.
    - Range must be within 2 miles (+ or -) of correct range.
  - TRANSMIT STRANGER'S TRACK AND ANGELS
    - Transmit, to CAP, stranger's track and angels prior to the stranger closing within 3 miles of the CAP.
    - Transmitted track must be within 10 (+ or -) degrees of the stranger's heading.
    - Transmitted angels must be 1000 (+ or -) feet of the stranger's altitude.
  - "STRANGER OPENING"
    - Notify the CAP "STRANGER OPENING" within 10 seconds of stranger range steadily increasing for 2 sweeps in a row.
-

INSTRUCTION (V)  
Level 5 (E)

Unit 1

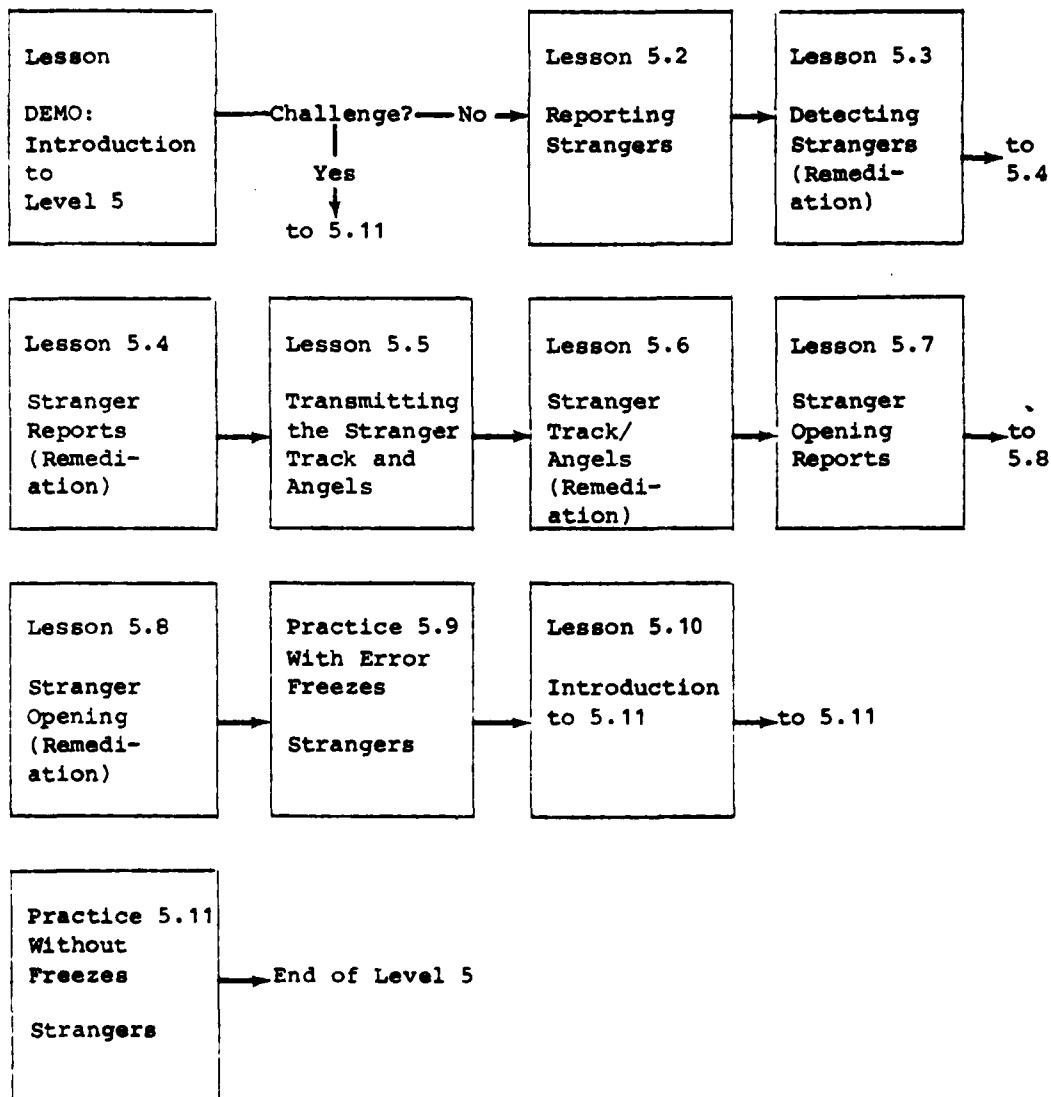

INSTRUCTION (SECTION V)  
Level 6 (Subsection F)

Introduction      Level 6 gives you the instruction you need to assist with aircraft rendezvous. You will learn the skills you need to perform the tasks of:

- making the initial calculations
- vectoring the aircraft for necessary turns
- making the appropriate voice calls.

In this level you will learn how to take the skills you learned in Levels 1, 2, and 3 and add to them those needed to assist with a rendezvous.

---

Importance      Rendezvous are an important part of operational aircraft maneuvers. Rendezvous are performed for the purposes of:

- tanking
- joining up during aircraft (or aircrew) emergencies
- joining up for RTB (Return-to-Base) after a mission.

Being able to quickly and accurately assist with rendezvous is therefore an important part of an AIC's job.

---

Subsection      This subsection explains the:  
Uses

- content, and
- organization

of this level. Read these materials so that you will know:

- what instruction and practice you will receive (and when)
  - what you'll be required to do to complete this level
  - how well you must perform the required skills in order to advance to Level 7.
-

INSTRUCTION (V)  
Level 6 (F)

Level  
 Organization

Level 6 is has only one unit. The instruction you received earlier that relates to this unit is shown in the following illustration:

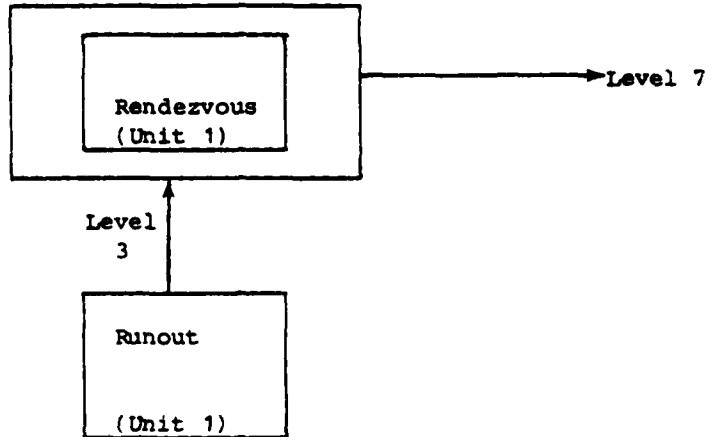

Unit

The following pages show the:

- new things you must do to be able to do to pass Level 6
- organization of the divisions within the unit of this level.

"What You'll be Expected to Do":

- MAKE INITIAL CALCULATIONS FOR RENDEZVOUS
  - Using the stated speeds of the CAP and MAC, calculate the distance of lateral separation for the rendezvous setup and the range at which to initiate the rendezvous turn.
- TRANSMIT VECTORS FOR RENDEZVOUS
  - Respond to the CAP message "REQUEST RENDEZVOUS WITH CRACKERJACK" within 10 seconds with the vector for rendezvous message for the CAP.

INSTRUCTION (V)  
Level 6 (F)

"What You'll be Expected to Do" (cont.):

● TRANSMIT VECTORS FOR RENDEZVOUS (cont.)

- Respond to the CAP message "REQUEST RENDEZVOUS WITH CRACKERJACK" within 24 seconds after the CAP request with the vector for rendezvous message for the MAC.
- CAP vector must be within 10 degrees (+ or -) of the bearing from the CAP to the MAC.

● ATTAIN CORRECT LATERAL SEPARATION

The lateral separation (perpendicular distance from the line of flight of the CAP to the maneuvering aircraft (MAC)), should be the mach number of the MAC X 10 miles when the range between the MAC and the CAP (combined mach of the two A/C) is X 10 + 2 miles.

● TRANSMIT TO THE MAC THE BEARING AND RANGE TO THE CAP

- Transmit message "CALLSIGN, bearing, range" prior to the MAC's turning for rendezvous.

● TRANSMIT MAC'S ALTITUDE TO CAP FOR RENDEZVOUS

- Respond to the CAP message "REQUEST RENDEZVOUS WITH CRACKERJACK" with the MAC's altitude within 36 seconds after the vector call.
- The transmitted altitude must be the correct altitude as displayed in the DRO.

● MEASURE RENDEZVOUS FLIGHT PATH

The perpendicular distance from the MAC to the line of flight of the CAP, after turn for rendezvous is complete, should be 0 to 1 mile.

● MEASURE RENDEZVOUS SEPARATION

The distance forward from the CAP to the intersecting perpendicular of the MAC along the CAP's line of flight, after the rendezvous is complete, should be from 0 to 1 mile.

INSTRUCTION (V)  
Level 6 (F)

"What You'll be Expected to Do" (cont.):

- TRANSMIT TO THE CAP THE BEARING AND RANGE TO THE MAC
    - Transmit the CAP bearing and range to the MAC within 12 seconds after the MAC turn for rendezvous is started. The transmissions should be made 3 out of 5 sweeps, not missing any 2 sweeps in a row.
    - Transmitted bearing must be within 2 degrees (+ or -) of that displayed on NTDS.
    - Transmitted range must be within 2 miles (+ or -) of that displayed on NTDS.
-

INSTRUCTION (V)  
Level 6 (F)

Unit 1

(No Challenge Option)

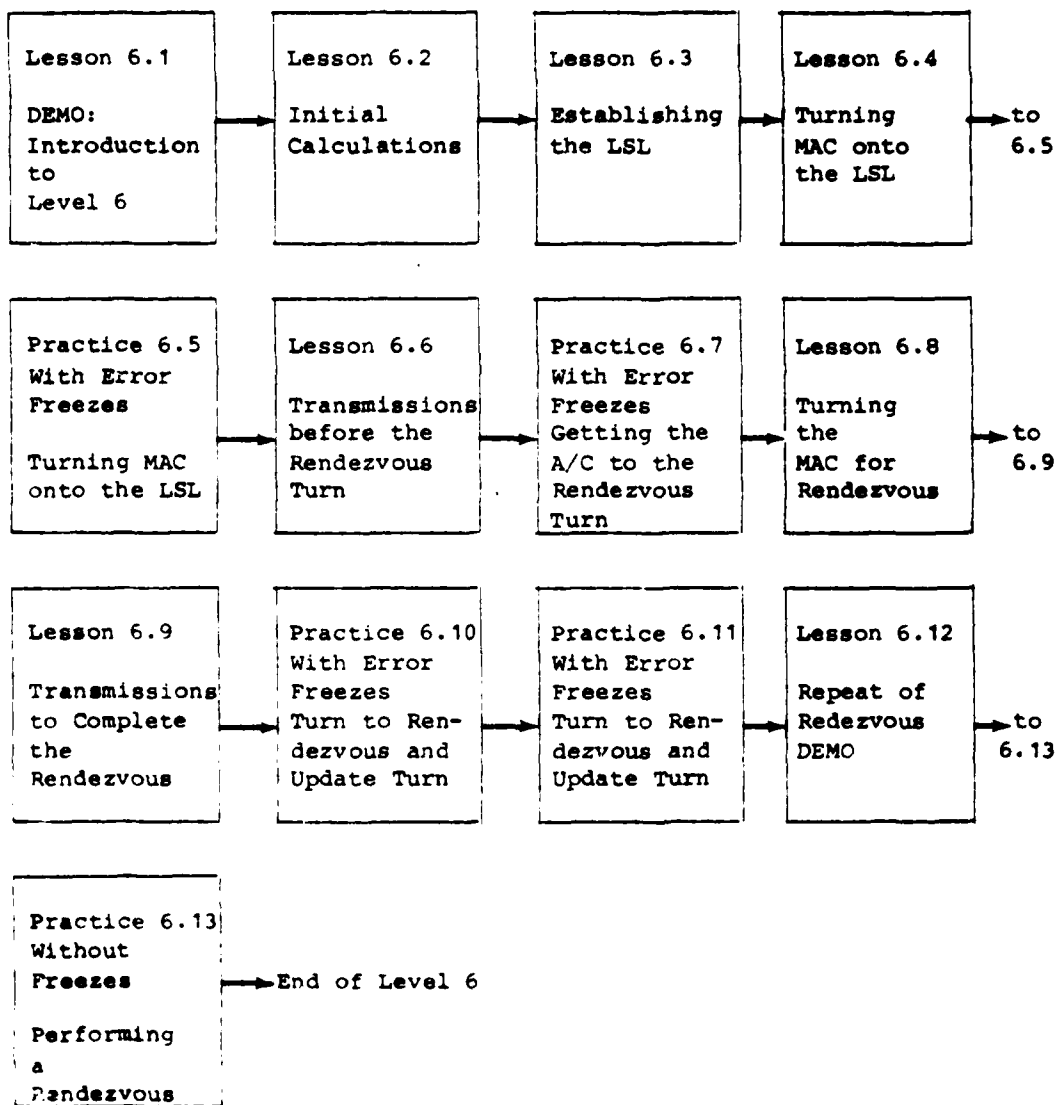

INSTRUCTION (SECTION V)  
Level 7 (Subsection G)

Introduction      Level 7 introduces you to three complications with which the AIC must deal:

- radar fades
- NTDS failure
- aircraft and aircrew emergencies.

In this level you will learn how to:

- notify the CAP of radar fades
- call bearing and range using only NTDS
- notify the CAP of NTDS failure
- call bearing and range using only radar or only markings of past radar returns
- detect emergencies
- determine the appropriate way(s) to assist an aircrew experiencing a described emergency.

Level 7 "pulls it all together" in terms of dealing with bogey intercepts. You will not only practice assisting with a basic intercept but you also will practice dealing with:

- bogey jinks and splits
- strangers
- radar fades
- NTDS failure
- emergencies.

Level 8 then deals only with aircrew training setups.

Importance

The skills involved in dealing with radar fades, NTDS failure, and aircraft/aircrew emergencies are ones you need to develop to be an effective AIC. These are real problems you can encounter in the tactical (and non-tactical) aircraft

INSTRUCTION (V)  
Level 7 (G)

Importance  
 (cont.)

environment. It is important that you are capable of handling them plus the basic jobs involved in assisting with intercepts. The practice exercises in this level will help you practice everything you've learned so far in the course (except rendezvous).

Subsection  
 Uses

This subsection explains the:

- content, and
- organization

of this level. Read these materials so that you will know:

- what instruction and practice you will receive (and when)
- what you'll be required to do to complete this level
- how well you must perform the required skills in order to advance to Level 8.

Level  
 Organization

Level 7 is divided into three units. These are illustrated in the following figure:

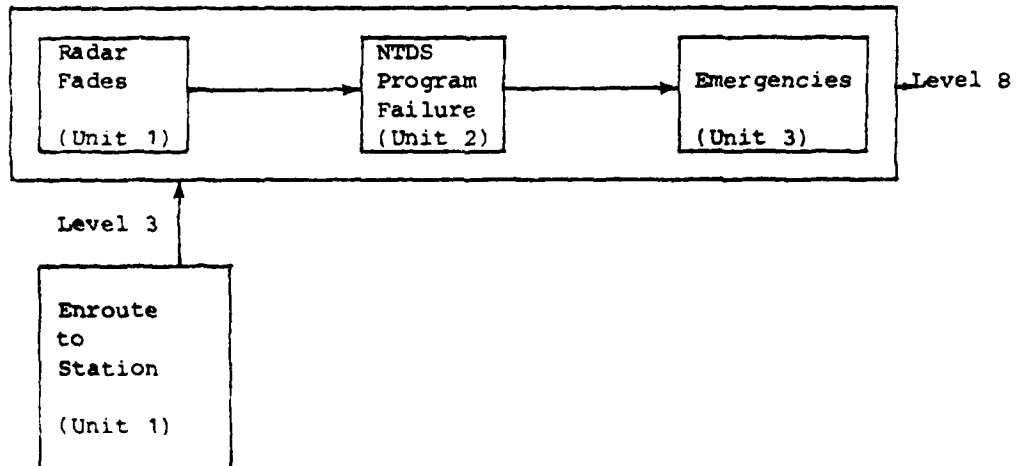

INSTRUCTION (V)  
Level 7 (G)

Units

The following pages show the:

- new things you must be able to do (per unit) to pass Level 7
  - organization of the divisions within Units 1 to 3 of this level.
- 

"What You'll be Expected to Do"

(Unit 1)

- "FIGHTER IN THE DARK"
    - Transmit the message "FIGHTER IN THE DARK" if the CAP is on station and 3 consecutive fades of the CAP video occurs, or if the CAP is intercepting the bogey and 2 consecutive fades occur. Message must be transmitted within 15 seconds of the determining fade.
  - "BOGEY IN THE DARK"
    - Transmit the message "BOGEY IN THE DARK" if the CAP is on station and 3 consecutive fades of the bogey video occurs, or if the CAP is intercepting the bogey and 2 consecutive fades occur. Message must be transmitted within 15 seconds of the determining fade.
  - Plus the requirements for Level 2 (heading and bearing and range calls) without radar.
- 

(Unit 2)

- TRANSMITTING NTDS DOWN MESSAGE
  - Transmit to the CAP the message "MY OCTOPUS IS BENT" within 18 seconds of NTDS program failure.
- INITIAL BEARING AND RANGE TRANSMIT, NTDS DOWN
  - Transmit (to the CAP) the bogey's bearing and range or the station's bearing and range within 30 seconds after NTDS program fails.
  - Transmitted bearing must be within 5 degrees (+ or -) of the correct bearing for all ranges.

INSTRUCTION (N)  
Level 7 (G)

"What You'll be Expected to Do" (cont.):

(Unit 2)  
(cont.)

- INITIAL BEARING AND RANGE TRANSMIT, NTDS DOWN (cont.)
    - Transmitted range must be within:
      - +/- 3 miles for 0 - 10 miles separation
      - +/- 5 miles for 10 - 20 miles separation
      - +/- 7 miles for 20 - 40 miles separation
      - +/- 10 miles for greater than 40 miles separation.
  - CONTINUOUS BEARING AND RANGE TRANSMIT, NTDS DOWN
    - Transmit to the CAP the bearing and range to the bogey or the station, 3 out of 5 sweeps (missing making transmissions on no more than 2 sweeps in a row) after the NTDS program fails and the initial call has been made.
    - Transmitted bearing must be within 5 degrees (+ or -) of the correct bearing at any range.
    - Transmitted range must be within:
      - +/- 3 miles for 0 - 10 miles separation
      - +/- 5 miles for 10 - 20 miles separation
      - +/- 7 miles for 20 - 40 miles separation
      - +/- 10 miles for greater than 40 miles separation.
- 

(Unit 3)

- IDENTIFICATION OF EMERGENCY SITUATIONS
  - Using symptoms of an emergency on board an aircraft and names of several emergencies, correctly match the name of the emergency to the symptoms described.
- IDENTIFICATION OF APPROPRIATE EMERGENCY PROCEDURES
  - Using a named emergency on board an aircraft and a list of aircrew assistance procedures, correctly match the emergency to the appropriate procedures.
- ESTABLISHING COMMUNICATIONS AFTER ALARM SOUNDS (BEEPER ON GUARD)
  - Transmit message "CALLSIGN RADIO CHECK" within 10 seconds after Beeper on Guard alarm sounds.

INSTRUCTION (V)

Level 7 (G)

"What You'll be Expected to Do" (cont.):

(Unit 3)  
(cont.)

- REPORTING CAP EMERGENCY TO SWC
  - Transmit message to SWC "CALLSIGN EMERGENCY" within 30 seconds of unsuccessful attempted communications with the CAP.
  
- CHECK EMERGENCY PLOT POSITION
  - In response to the request, "State bearing and range from ownship to emergency," make the transmission "EMERGENCY \*\*\* (bearing) ## (range)" within 20 seconds.
  - The bearing must be within 5 degrees (+ or -) of correct.
  - The range must be 2 miles (+ or -) of correct.

Unit 1

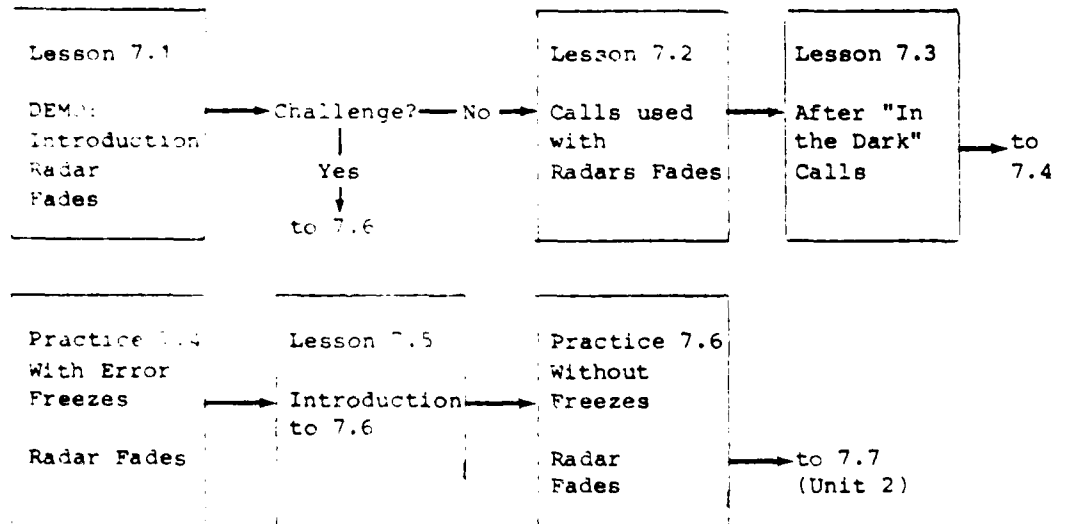

AD-A106 999

LOGICON INC SAN DIEGO CA TACTICAL AND TRAINING SYSTEM--ETC F/G 5/9  
PROTOTYPE EQUIPMENT STUDENT GUIDE FOR ACE (AIR INTERCEPT CONTROL--ETC(U)  
SEP 81 N M SMITH, R D GRANBERRY, R HALLEY N61339-78-C-0182  
8641-A00A NAVTRAEQUIPC-78-C-0182-10 NL

UNCLASSIFIED

2  
2  
4

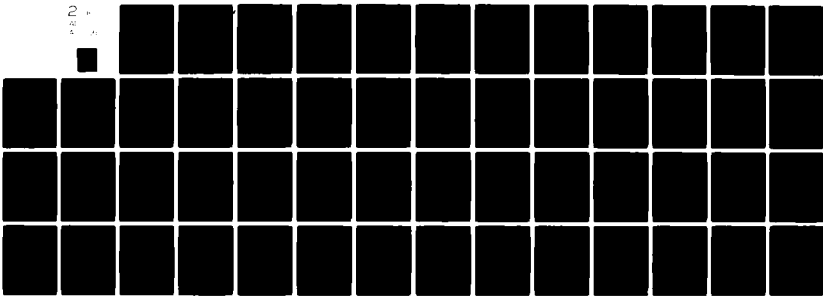

END  
DATE  
FILMED  
12 81  
DTIC

INSTRUCTION (V)  
Level 7 (G)

Unit 2

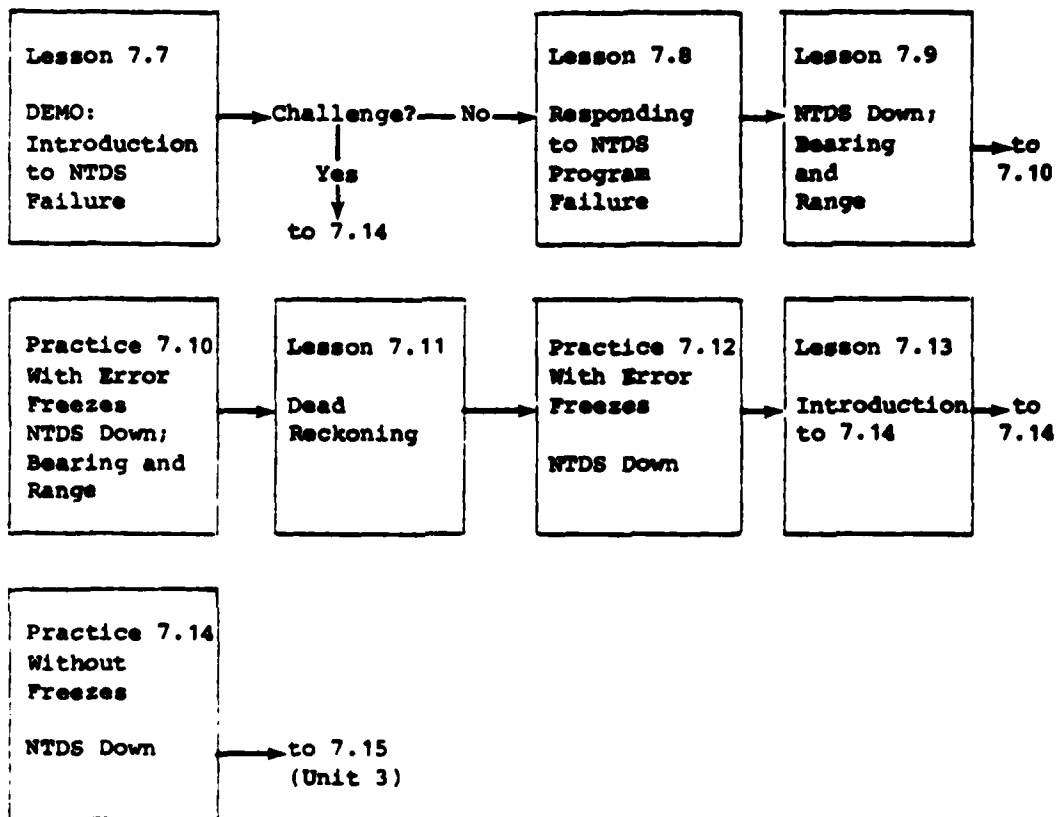



INSTRUCTION (SECTION V)  
Level 8 (Subsection H)

**Introduction** Level 8 introduces you to the aircrew training environment and the skills you need to plan aircrew training setups.

In this level you will learn how to:

- plan and help carry out head-on intercepts and tail-to-tail breakaway headings
- adjust the target aspect angle and aircraft separation.

You will practice running setups with the standards for success gradually growing higher. By the time you complete this level, you will have successfully completed the instruction and practice exercises the ACE course offers. You will have had training in the basic AIC skills used in the:

- tactical
- operational
- aircrew training environments.

Most of the skills you must learn and practice in the aircrew training environment are new. You will have not used these skills in Levels 1 through 7. Some of the skills you learned in Levels 2 and 3 will be used in Level 8, but they will be applied to a different set of situations.

---

**Importance**

Much of your time as an AIC during peacetime is spent assisting with aircrew training setups. This is not to say you won't have opportunities to practice your tactical environment skills. However, with the rising cost of fuel, the military must focus its efforts on training its air personnel in the most efficient way possible. Aircrews need the most practice in executing the last phases of intercepts. Setups provide them with concentrated practice on the most essential skills. It is more costly in terms of time and money to regularly simulate all aspects of the tactical environment. You will have a more limited number of opportunities to practice all of your tactical environment skills. However, should the need arise, your expertise in the tactical environment would be vital to the defense of the fleet.

As a student, Level 8 has some immediate importance for you. In level 8 you prepare for entering the live air control phase of your AIC School training. In order to successfully complete AIC School you will need to demonstrate your ability to assist with aircrew training.

---

**INSTRUCTION (V)**  
**Level 8 (H)**

**Subsection**  
**Uses**

This subsection explains the:

- content, and
  - organization
- of this level. Read these materials so that you will know:
- what instruction and practice you will receive (and when)
  - what you'll be required to do to complete this level
  - how well you must perform the required skills in order to complete this course.

**Level**  
**Organization**

Level 8 is divided into four units. These are illustrated in the following figure:

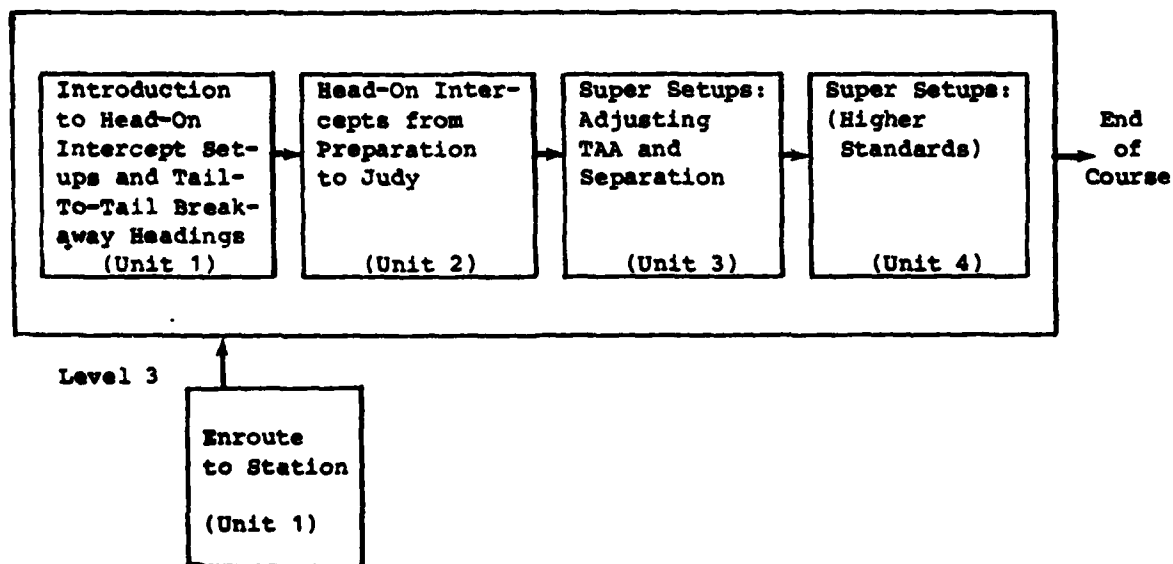

**Units**

The following pages show the:

- new things you must be able to do per unit to pass Level 8
- organization of the divisions within Units 1 to 4 of this level.

INSTRUCTION (V)  
Level 8 (H)

"What You'll be Expected to Do":

(Unit 1)

- KEEP AIRCRAFT IN THE AREA
  - Once the aircraft have entered the area, keep them in the area 100 percent of the time.
- BREAKAWAY
  - Transmit the message "CALLSIGN (PORT/STARBOARD) ###" within 25 seconds after receiving the message "FOX 1, BREAKAWAY" from the CAP.
- DISENGAGE PSEUDO BOGEY FROM A POINT-IN-SPACE ("B")
  - After the pseudo bogey has been engaged from point-in-space "A", hit "BREAK/CANTCO" to disengage after 100 seconds and before 175 seconds.
- DISENGAGE CAP FROM A POINT-IN-SPACE ("A")
  - When, after a breakaway request or the wingman has been detached, the CAP has been engaged to a point-in-space, hit "BREAK/CANTCO" to disengage after 105 seconds and before 180 seconds.
- ENGAGE PSEUDO BOGEY TO POINT
  - After a breakaway request or after the CAP enters the OPAREA, depress GEOM VAB to get trial engagement of the pseudo bogey to a point within 18 seconds.
- ENGAGE CAP TO POINT
  - After receiving a breakaway request or detaching the wingman, ball tab a point, depress GEOM VAB to get trial engagement of the CAP to a point within 15 seconds.
- ENGAGE PSEUDO BOGEY TO PPOI
  - After the pseudo bogey has been disengaged from a point-in-space, engage the pseudo bogey to the PPOI by ball tabbing a new point and hitting GEOM within 12 seconds.
- ENGAGE CAP TO PPOI
  - After engaging the pseudo bogey to the PPOI, engage the CAP to the PPOI by sequencing to CAP by ball tabbing the same point 2 miles (+ or -), and hitting GEOM within 12 seconds.

INSTRUCTION (V)  
Level 8 (H)

"What You'll be Expected to Do" (cont.):

(Unit 1)  
(cont.)

- DISENGAGE CAP FROM PPOI
  - After the turn for intercept "FOR BOGEY" is transmitted, sequence to CAP and hit BREAK/CANTCO VAB within 36 - 48 seconds.
- VECTOR CAP TO BOGEY IN TRAINING
  - After the pseudo bogey is turned for vector as bogey, vector the CAP to the PPOI within 12 seconds.
- ENGAGE CAP TO PSEUDO BOGEY IN TRAINING
  - After the pseudo bogey is steady on the vector as bogey, engage the CAP within 9 seconds.

---

(Unit 2)

- DIRECT CAP TO CENTER OF AREA
  - If the aircraft heading is greater than 15 degrees off the heading to the center of the area, transmit the message "c/s (PORT/STARBOARD) ###" within 35 seconds of the CAP check-in.
  - If the heading is transmitted, it must be within 15 degrees (+ or -) of the correct heading to the center of the training area.
- SELECT 32 MILE RANGE SCALE FOR SETUPS
  - Select the 32 mile range scale prior to the CAP going into the OPAREA.
- UPDATE NTDS-STATE
  - Update the CAP state, if required, before the CAP turns for intercept.
  - Update the pseudo bogey state, if required, before the pseudo bogey turns for intercept.
- REQUEST PSEUDO BOGEY STATE (TRAINING)
  - Transmit the message "CALLSIGN WHAT STATE" to the pseudo bogey before he turns for intercept.

INSTRUCTION (V)  
Level 8 (H)

"What You'll be Expected to Do" (cont.):

(Unit 2)  
(cont.)

- REQUEST PSEUDO BOGEY STATE (TRAINING) (cont.)
  - Respond to the pseudo bogey's message "STATE ###" with "ROGER, STATE ###" within 10 seconds.
- REQUEST CAP STATE (TRAINING)
  - Transmit the message "CALLSIGN WHAT STATE" to the CAP before the CAP turns for intercept.
  - Respond to the CAP's message "STATE fff" with "ROGER, STATE fff" within 10 seconds.
- ENTER CAP SYMBOLS AND PIF
  - The CAP symbols for the CAP and the pseudo bogey are entered prior to the start of the scenario action.
  - The PIF is correct for the CAP.
  - The PIF is correct for the pseudo bogey.
- RANGE SCALE AND OFFSET (TRAINING ENVIRONMENT)
  - The range scale is set to 64 miles at the time the offset is entered.
  - The offset is entered within 60 seconds from the start of the exercise.
  - The new ownship position is such that the TACAN station and the OPAREA outline are visible on the screen.
- UPDATE TURN RATE
  - The bank angle for both the CAP and the pseudo bogey must be updated to 3 deg/sec in NTDS prior to the beginning of the scenario.
- PSEUDO BOGEY SYMBOL UPDATE
  - Maintain the pseudo bogey symbol such that 3 out of 5 times that the video is displayed, missing no more than 2 video displays in a row, the pseudo bogey symbol is within 1/8 inch of the video.

INSTRUCTION (V)  
Level 8 (H)

"What You'll be Expected to Do" (cont.):

(Unit 2)

- UPDATE PSEUDO BOGEY SYMBOL
  - Update the pseudo bogey symbol within 20 seconds after receiving the CAP check-in message.
  - Pseudo bogey symbol (CAP2) is placed within 1/8" of the position of the pseudo bogey video.
- DIRECT CAP TO CENTER OF AREA
  - If aircraft heading is greater than 15 degrees off the heading to the center of the area, transmit message "CALLSIGN (PORT/STARBOARD) ###" within 35 seconds of CAP check-in.
  - If the heading is transmitted, it must be within 15 degrees (+ or -) of the correct heading to the center of the training area.
- ESTABLISH LOST COMMUNICATIONS
  - Transmit the message "CALLSIGN LOST COMMUNICATIONS INTENTIONS, OVER" to the CAP within 2 minutes of the CAP entering operating area.
  - Respond to the message "RENDEZVOUS POINT WHISKEY, ANGELS ##" with the message "ROGER LOST COMM" within 10 seconds.
- DETACH WINGMAN

Make the transmission "CRACKERJACK DETACH STARBOARD ###" within 15 seconds of trial engagement of pseudo bogey (GEOM VAB depressed) to point "B". (point in space)
- ESTABLISH INITIAL AND FINAL INTERCEPT CONDITIONS
  - When the two aircraft have been turned for the intercept and are steady on course, target aspect angle should be within 5 degrees of planned.
  - CAP was able to close within 3 miles of pseudo bogey at closest point before crossing.

INSTRUCTION (V)  
Level 8 (H)

"What You'll be Expected to Do" (cont.):

(Unit 2)  
(cont.)

● MEASURE SETUP SEPARATION

- When the two aircraft have been turned for the intercept and are first steady on course, the separation should be within 3 miles of planned.
- 

(Units 3  
and 4)

- Perform all the skills taught in Units 1 and 2 with higher standards for success.
- 

Unit 1

(No Challenge Option)

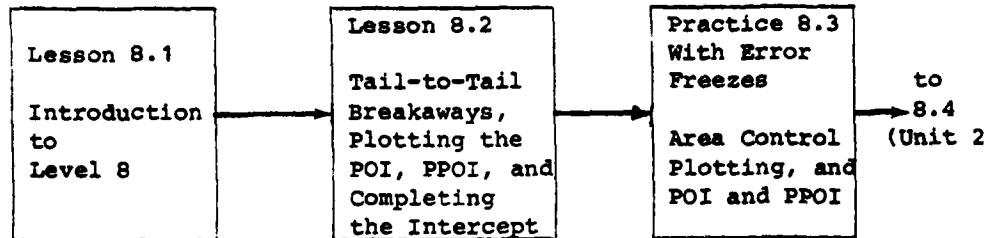

INSTRUCTION (V)

Level 8 (H)

Unit 2

(No Challenge Option)

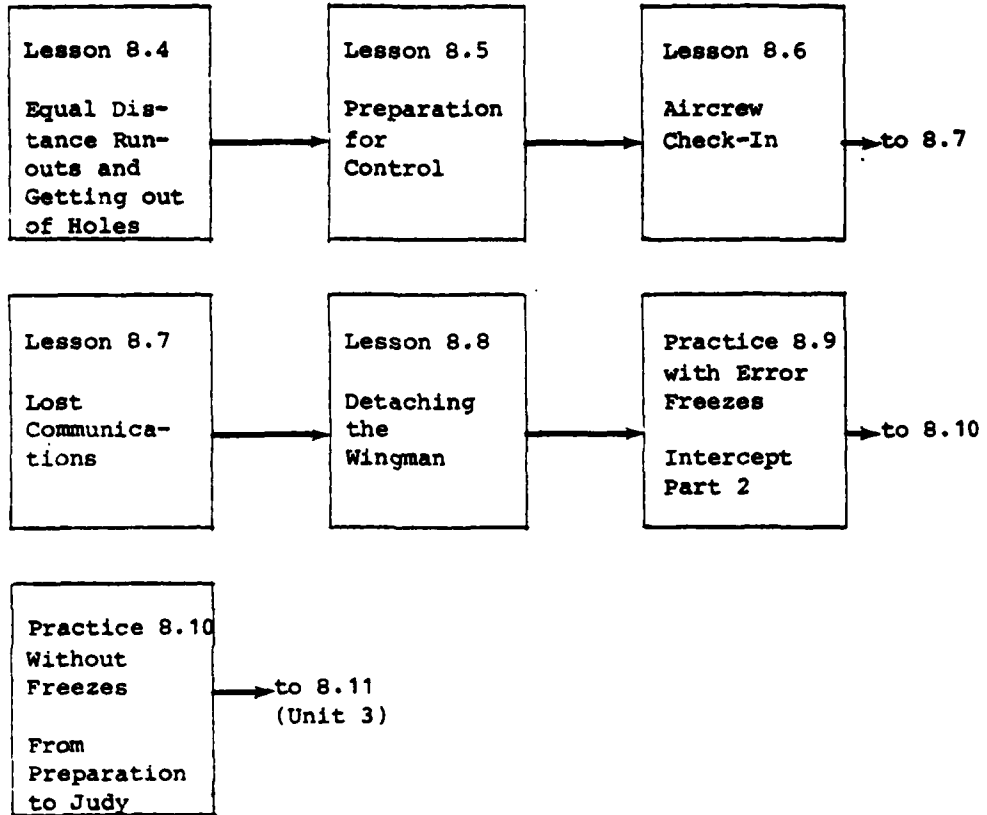

INSTRUCTION (V)  
Level 8 (H)

Unit 3

(No Challenge Option)

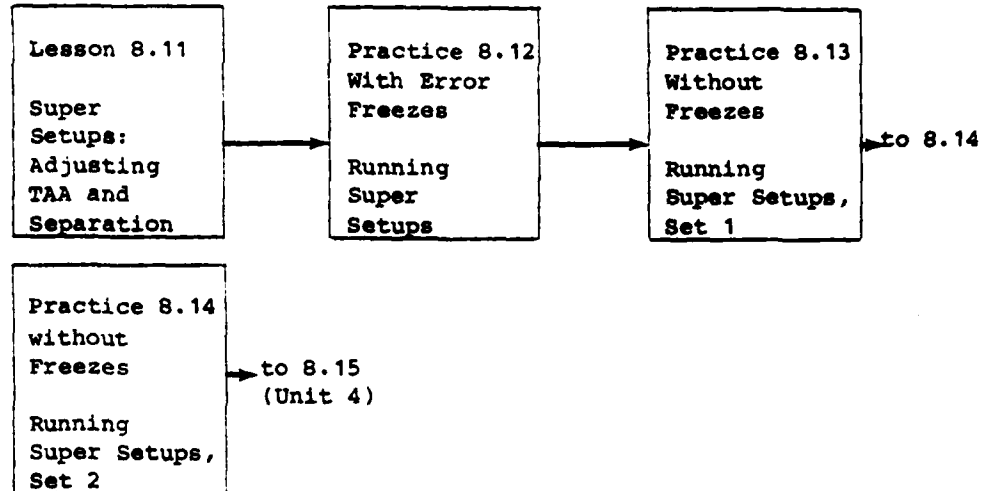

Unit 4

(No Challenge Option)

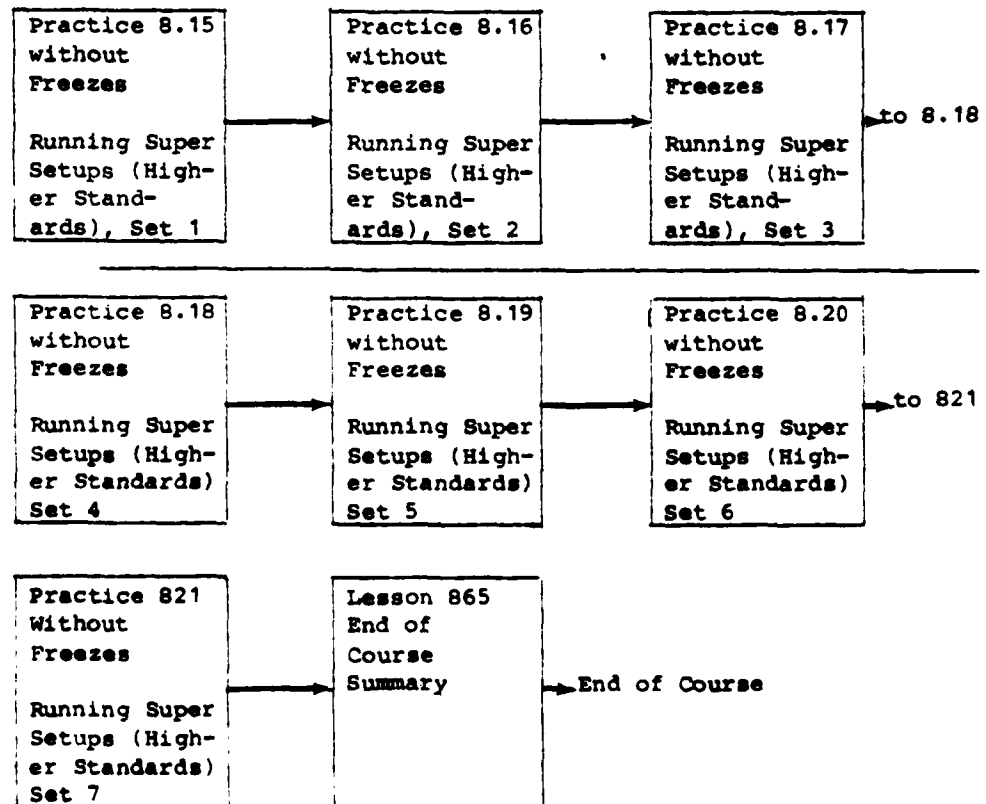

ACE STUDENT GUIDE

System Messages (Section VI)

Introduction      The ACE system will tell you how well you are doing:

- after you answer each question on a test
- after you complete a check (perform the steps in a procedure on the console)
- whenever you put data into the console during a practice exercise
- whenever you make a mistake on a PMV that causes the exercise run to end (Practices with Error Freezes)
- whenever you finish a practice exercise
- after you practice making a new voice call
- after you make a voice call while training (or retraining) the system to recognize you
- after you make call to test the system's recognition of your voice.

---

Message Forms      The system will "talk to you" through:

- CRT displays (at the Student Station CRT or the Console CRT)
- beeps, buzzers, lights and DROs at the console
- blinking letters and numbers on the CRTs
- voice prompts
- TV screen presentations (with or without motion).

---

Message Use      The responses you receive from the system are designed to help you know:

- if your answers or console actions are correct
- if you are entering or obtaining the information you want
- if the system is responding correctly to your actions

ACE STUDENT GUIDE  
System Messages (VI)

Message Use  
(cont.)

You can use this information to:

- change what you are doing (or plan to do)
  - determine if the system is working as you think it should
  - determine if the instructor should be called to help you.
- 

Subsections

The following subsections show examples of the TV displays, CRT messages and voice prompts you could receive:

- during tests
- after checks (or before re-runs of checks)
- during and upon completing practice exercise runs
- during and upon completing speech:
  - practice
  - collection
  - validation.

The other forms in which system responses could occur are noted where appropriate.

---

SYSTEM MESSAGES (SECTION VI)  
Tests (Subsection A)

Introduction Tests are used in the ACE course to offer you practice in remembering or using new information. Test items are in one of three forms:

- matching
- true-false
- multiple choice.

CRT  
Messages

After you answer a test question, the ACE system will immediately tell you if your answer was correct or incorrect, and when incorrect, if you can try again. Usually this information is given to you as a message on the Student Station CRT.

Sample  
Messages

Samples of system messages after a:

- correct response
- incorrect response (first try)
- incorrect response (second try)

are shown in the following three boxes.

EXAMPLE (Correct Response)

Well done! Your answer is correct.  
Press NEXT to go on to another question.

EXAMPLE (Incorrect Response - first try)

Your answer is incorrect.  
The correct answer is #3.  
The "state and status" report tells you the CAP's current ...  
  
3. fuel load (state) and missile inventory (status)

SYSTEM MESSAGES (VI)

Tests (A)

Sample  
Messages (cont.)

EXAMPLE (Incorrect Response - second try)

Your answer is incorrect.  
Do nothing now.  
The instructor will come to help you.

TV and CRT  
Presentations

Sometimes the system will also use TV screen presentations to:

- show you what your answer should look like
- illustrate a situation which you can answer questions about.

These pictures are accompanied by CRT messages which explain your questions about them.

Sample  
Presentations

The following illustrations show:

- a correct answer against which you could compare your work
- an incorrect answer which asks if your work looks the same
- a response to an incorrect answer (including the correct response).

EXAMPLE (Correct Answer)

(TV SCREEN) (Illustration of which side of the CAP track the LSL should have been drawn)

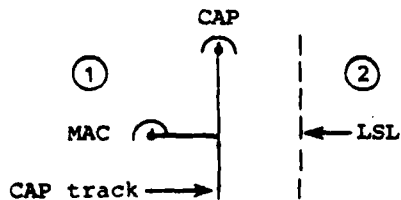

(CRT) You should have drawn the LSL on side 2.

SYSTEM MESSAGES (VI)

Tests (A)

Sample  
Presentations  
(cont.)

EXAMPLE (Incorrect Answer)

(TV SCREEN)

(CRT) Did you draw the LSL on side 1 as shown in the picture?

Press YES or NO

EXAMPLE (System Reply to Incorrect Response)

(TV SCREEN)

(CRT) (If answer was YES): Your answer is incorrect. The LSL should have been drawn on the side of the CAP track to which the MAC is heading. The LSL should be on side two in this case.

SYSTEM MESSAGES (SECTION VI)  
Checks (Subsection B)

**Introduction** Checks are used in the ACE course to provide you with practice performing the steps of a new procedure. Each check is a set of steps you must perform on the console within a certain amount of time.

---

**Message Forms** The system can respond to your inputs on the console with:

- DRO presentations
- lights on the console (blinking or steady)
- buzzers
- scope displays.

These act as indicators which you can interpret. Since the console simulates the actions of a real NTDS console, you can interpret the displays which appear as a result of your inputs just as you would interpret those on a real console.

In addition, the console CRT can provide messages telling you that your inputs for the check were:

- correct, or
- incorrect.

Incorrect, first try responses, may also be explained as:

- an error of omission (step(s) left out)
  - an error of sequence (step(s) done in wrong order)
  - another type of error (perhaps more than one).
- 

**Sample Messages**

The following illustrations show the types of CRT messages you can receive after completing a check. Note that if you make any type of error on a second try on the check, the instructor will be called over to determine what it is you're doing wrong and how it can be corrected.

**EXAMPLE** (Correct Response)

You did that correctly!

Press NEW CAP to continue.

SYSTEM MESSAGES (VI)

Checks (B)

Sample  
Messages  
(cont.)

EXAMPLE (Omission Error - first try)

One of the steps was left out. The correct steps are:  
  
(list of steps)  
  
Press NEW CAP and try again.

EXAMPLE (Sequence Error - first try)

The steps were done in the wrong order. The correct order is:  
  
(list of steps)  
  
Press NEW CAP and try again.

EXAMPLE (Other Error - first try)

The steps were done incorrectly. Try again.  
  
Be sure to do all of these steps in the correct order:  
  
(list of steps)  
  
Press NEW CAP to proceed.

EXAMPLE (Incorrect Response - second try)

The steps were done incorrectly. Do nothing now. The instructor will come to help you complete these steps (list of steps).

---

SYSTEM MESSAGES (SECTION VI)  
Practice Exercises (Subsection C)

**Introduction** Practice exercises (With and Without Error Freezes) are used in the ACE course to provide you with opportunities to rehearse the AIC's basic duties using simulation. The skills practiced with these exercises are ones learned in previous lessons.

---

**Freeze Messages** During a Practice with Error Freezes, if you make a mistake on a "Freeze" PMV (see Subsection IV A), a special CRT message will appear:

EXAMPLE (Error on Freeze PMV)

This exercise has been stopped because you made an important error in the material most recently learned. The error made is shown below. Try to avoid repeating this mistake when the exercise starts over at the beginning. Your error was:

A PMV error summary on the run will follow this display. When the error summary is finished, the exercise will start over with a new run.

---

**Other Messages** On either type of practice exercise, you will receive CRT messages which:

- summarize the errors made on that run
  - state that you will now receive more instruction on your problem areas
  - state that the instructor will now come to help you
  - say that the practice has been successfully completed and that a break can now be taken.
- 

**Sample Messages** The following examples illustrate the types of CRT messages you may see after:

- completing an exercise run
- completing an entire exercise successfully.

SYSTEM MESSAGES (VI)  
Practice Exercises (C)

Sample  
Messages  
(cont.)

EXAMPLE (Error Summary)

The problems you had with this run were as follows:

- >Offset not entered within 60 seconds of exercise start.
- >Incorrect PIF for the CAP.
- >CAP altitude does not match CAP station altitude.

Press NEW CAP to continue.

EXAMPLE (Remediation)

Now you will have a chance to review these problem areas. You will review the skills in the order in which you learned them.

Go to the STUDENT STATION CRT. Press NEXT when you're ready to start the review.

EXAMPLE (Instructor Called)

You need some more help on these problem areas. The instructor will now come to assist you.

EXAMPLE (End of the Practice)

Now that you have finished this practice, you should go to the STUDENT STATION CRT for directions on how to proceed.

When you get the STUDENT STATION, press NEXT to continue.

SYSTEM MESSAGES (VI)  
Practice Exercises (C)

Sample  
Messages  
(cont.)

EXAMPLE (Break Time)

You deserve a little time off the system. Take a 5 to 10 minute break:

>Press the BREAK button, then "ENTER" and turn down the console lights.

When you return from your break,  
>press the CONTINUE button

then, to proceed,

>press the NEXT button.

Other System  
Responses

Throughout practice exercises, as with checks, the console will react to your inputs. The

- DRO displays
- scope displays
- console lights

can indicate how well you are doing in an exercise. In addition, the system will react to your voice calls. The reaction may come in the form of:

- scope displays (aircraft movements)
- system voices (CAP, SWC, pseudo-bogey, or MAC).

As with other console responses, what you would expect to have happen in the real world (in a similar situation) should be the yardstick against which you measure the system's outputs. If the system is reacting as you would expect, then your inputs are probably being interpreted accurately. The messages on the CRT give you the "final word" on any errors you might have made in a run that didn't show up in the system's other responses.

SYSTEM MESSAGES (VI)  
Practice Exercises (C)

Related  
Materials

Refer to the following materials for additional information about practices:

- Subsection IIIB ("System user Notes - Console")
  - Subsections IV A and B ("Scoring on Practice Exercises")
  - Section V ("Instruction")
  - Supplements:
    - C ("AIC Training Vocabulary")
    - F ("Team Member Messages" [CAP, SWC, Pseudo Bogey/Mac])
-

SYSTEM MESSAGES (SECTION VI)  
Speech Practice (Subsection D)

**Introduction**      Speech Practice in the ACE course is a routine designed to allow you to warm up your voice and practice the proper pausing on a new voice call. Speech practice is provided when you must learn a new phrase:

- during a lesson
- as a result of selecting to use your challenge option.

In the first case, you will first be told all about the call's meaning and correct usage. With the challenge situation, you practice the call and then train the system to recognize you saying it (with Speech Collection) only because the call is a new one and will be used in the Practice Without Freezes you'll be entering.

**Procedure**              During a Speech Practice, you will be told what the call is and how to say it. This will be done by a message on the console CRT and a system voice prompt. The CRT will tell you to make the call after hearing the system's voice say it. A sample Speech Practice follows:

Sample  
 Speech  
 Practice

EXAMPLE

(CRT)

Practice transmitting the following message. ACE will say it first; then you are to say it. We'll do that until you say it correctly twice. Remember to use correct voice procedures including how:

- \* >loudly you speak
- >you say the words (pauses in the right places)
- >you use the foot switch.

Are you ready? If you are:

- >press the foot switch
- >say "Ready"
- >release the foot switch.

\*See Subsection III A for "Rules for Good Speech Recognition".

SYSTEM MESSAGES (VI)  
Speech Practice (D)

Sample  
Speech  
Practice  
(cont.)

(CRT and voice prompt)

Crackerjack...mark your TACAN

System  
Responses

When you have made a transmission, the system will let you know how well you did. This will come in the form of a CRT message with, where necessary, a system voice re-prompt. The system will let you know if:

- you made an error (any one of several types)
- your voice level was too low
- your voice level was too high
- you released the foot switch too early
- the foot switch was depressed too late
- you made no error (first practice)
- you made no error (second practice)

Sample  
Messages

The following examples illustrate the form and content of the system's possible responses to your practice transmissions.

EXAMPLE (General Error)

(CRT)  
Sorry! ACE didn't hear what you were expected to say.

Try again. When you are ready:

- >press the foot switch
- >say "Ready"
- >release the foot switch.

(followed by a voice re-prompt)

SYSTEM MESSAGES (VI)  
Speech Practice (D)

Sample  
Messages  
(cont.)

EXAMPLE (Voice Level Too Low)

(CRT)  
Sorry! Your voice level is too low. Do you have:

- >the microphone positioned properly?
- >the volume control properly adjusted?

Are you projecting your voice? Try again. When you are ready:

- >press the foot switch
- >say "Ready"
- >release the foot switch.

(followed by a voice re-prompt)

EXAMPLE (Voice Level Too High)

(CRT)  
Sorry! Your voice level is too high. Do you have:

- >the microphone positioned properly?
- >the volume control properly adjusted?

Are you speaking normally, without forcing your voice?

Try it again. When you are ready:

- >press the foot switch
- >say "Ready"
- >release the foot switch.

(followed by a voice re-prompt)

SYSTEM MESSAGES (VI)  
Speech Practice (D)

Sample  
Messages  
(cont.)

EXAMPLE (Foot Switch Released Too Early)

(CRT)  
Sorry! You released the foot switch too soon. Remember to wait until you have finished speaking to release the foot switch.

Try again. When you are ready:

>press the foot switch  
>say "Ready"  
>release the foot switch

(followed by a voice re-prompt)

EXAMPLE (Foot Switch Depressed Too Late)

(CRT)  
Sorry! You depressed the foot switch too late. Be sure that the foot switch is depressed before you begin to speak.

Try again! When you are ready:

>press the foot switch  
>say "Ready"  
>release the foot switch

(followed by a voice re-prompt)

EXAMPLE (No Error: First Good Practice)

(CRT)

Good! One more time.

(followed by a voice re-prompt)

SYSTEM MESSAGES (VI)  
Speech Practice (D)

Sample  
Messages  
(cont.)

EXAMPLE (No Error: Second Good Practice)

(CRT)

OK! That's enough practice on that transmission.

Related  
Materials

Supplement E contains a list of all of the voice prompts you will hear during Speech Practice. Supplement C contains a list of all of the phrases you will need to train the system to recognize.

SYSTEM MESSAGES (SECTION VI)  
Speech Collection (Subsection E)

Introduction      Speech Collection in the ACE course is a routine done:

- during instruction on a new voice call or when the challenge option is used (and new calls are needed in the upcoming Practice without Freezes)
- after the RETRAIN Key is depressed and the number of the phrase to be retrained is entered (See RETRAIN key, Subsection III A).

Procedures

In Speech Collection, you are allowing the system to "record" you saying a phrase at least twice. Later, when you say that phrase, the system will compare the newest transmission with the ones it has stored for you. If they match, it recognizes you correctly.

In Speech Collection, the Console CRT will present you with the message that it is time to train the system on the call. A CRT and voice prompt for the call will then follow. A Sample Speech Collection follows.

Sample  
Speech  
Collection

EXAMPLE

(CRT)

We will now train ACE to recognize you saying this transmission. ACE will say it first, then you are to say it. We'll do that twice. Be sure to put pauses in as indicated, even though you might be breaking one of the usual stylization rules. ACE needs some special help at times!

To prepare, check the microphone adjustment and level setting. Remember to use the foot switch and speak up. When you are Ready:

- >press the foot switch
- >say "Ready"
- >release the foot switch.

SYSTEM MESSAGES (VI)  
Speech Collection (E)

Sample  
Speech  
Collection  
(cont.)

(CRT and voice prompt)

Crackerjack...Mark your TACAN...

System  
Responses

After each transmission, a message on the console CRT will tell you if there was:

- a general problem
- any one of other errors noted in "Speech Practice" subsection
- no error (first good collection)
- no error (second good collection)

Samples of these messages follow.

Sample  
Messages

EXAMPLE (General Problem Message)

Sorry! ACE didn't hear all that was expected. Can you pause a little longer? About half a second is needed.

Try again! When you are ready:

- >press the foot switch
- >say "Ready"
- >release the foot switch.

(followed by a voice re-prompt)

EXAMPLE (No Error: First Good Collection)

Good! One more time.

(followed by a voice re-prompt)

SYSTEM MESSAGES (VI)  
Speech Collection (E)

Sample  
Messages  
(cont.)

EXAMPLE (No Error: Second Good Collection)

ACE now has been trained to recognize you saying this transmission. Let's move on!

Related  
Materials

---

Supplement E provides a list of the voice prompts you will hear in Speech Collection. Supplement C lists the vocabulary used in this course.

Subsection III A contains the rules to be followed during Speech Practice, Collection, and Validation. Materials in Subsection VI D note how Speech Practice relates to Speech Collection.

---

SYSTEM MESSAGES (SECTION VI)  
Speech Validation (Subsection F)

**Introduction**      Speech Validation in the ACE course is done to check the system's recognition of your voice on a particular transmission. Speech Validation follows Speech Collection during instruction or after a challenge is requested. It also occurs in response to the INIT VOICE TEST key being depressed. When validation occurs after collection you will be informed with a message on the console CRT. A sample message follows:

(CRT)

Let's make sure ACE can recognize you saying this transmission. You will be prompted on the screen to say the message. Be sure to transmit the message as you would during actual operations.

When you are ready to begin:

- >press the foot switch
- >say "Ready"
- >release the foot switch.

During validation, there is no system voice prompt prior to a transmission. The system will, however, echo what it recognized you to say.

**System Responses**

In addition to echoing what it recognized you to have said, the system will tell you if there was:

- a general problem
- a voice error (see "Speech Practice" subsection)
- no error (a good validation).

If after two trials there is not a good validation, you will be directed to retrain one or more phrases (see Subsection III A, RETRAIN key).

**Sample Messages**

Examples of the types of messages which can appear on the console CRT (after one or two transmissions) follow.

SYSTEM MESSAGES (VI)  
Speech Validation (F)

Sample  
Messages  
(cont.)

EXAMPLE (General Problem Message - First Try)

You were recognized to say:  
  
(varies)  
  
ACE expected you to say:  
  
Crackerjack; mark your TACAN  
  
Try it again. Say it now.  
  
(no prompt follows)

EXAMPLE (General Problem Message - Second Try)

You were recognized to say:  
  
(varies)  
  
ACE expected you to say:  
  
Crackerjack; mark your TACAN  
  
We recommend you retrain the phrases with which ACE has  
problems.

(You should then start the retraining recommended.)

EXAMPLE (No Error - A Good Validation)

ACE now recognizes you saying this transmission. Let's move on!

Related  
Materials

Be sure to review the materials in Subsections VI D and F so that you can better understand how the system's Speech Practice and Collection routines relate to Validation.

ACE STUDENT GUIDE  
AIC's Job Description (Supplement A)

Communication Links

The relationships of the AIC within the air defense organization are shown in the illustration below. This illustration focuses on the communication links within this group.

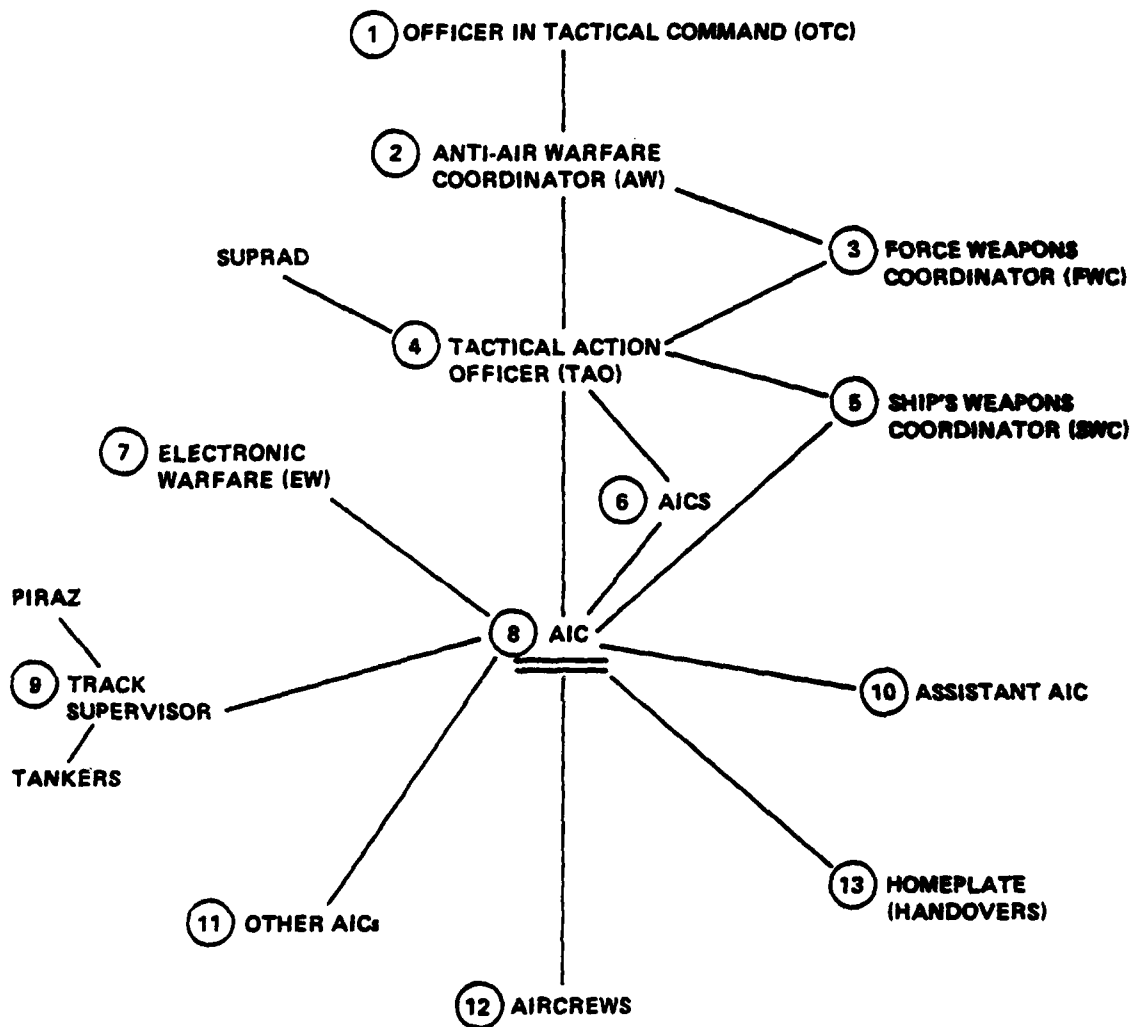

ACE STUDENT GUIDE  
AIC's Job Description (A)

The Officer in Tactical Command (OTC) (1) with a deployment of ships will usually designate someone to be (2) the Antiair Warfare Coordinator (AAWC). The OTC has the ultimate responsibility for all elements of the tactical situation (air, surface, and subsurface) for that group of ships. The AAWC assumes responsibility for just the antiair warfare (AAW) or air defense portion of the tactical situation. The AAWC adopts the voice radio call sign "ALPHA WHISKEY", or AW, and will be referred to as AW henceforth.

Working directly for AW can be (3) a Force Weapons Coordinator (FWC). The FWC can assign certain air defense tasks to individual ships and may or may not act as an intermediary between AW and (4) the Tactical Action Officer (TAO).

Each ship has a TAO working in its Combat Information Center (CIC). This officer is responsible for dealing with threats to his ship and for carrying out orders from AW. As with the OTC, the TAO is concerned with all elements of the tactical situation (air, surface, and subsurface) as they impact on his ship's mission and the safety of his ship.

Working directly for the TAO in the CIC is (5) the Ship's Weapons Coordinator (SWC). The SWC's task is to assign specific weapons to carry out the orders issued by the AW or to meet the threats identified by the TAO.

Depending on the size of ship, the next link in the chain of air defense is either (8) the Air Intercept Controller (AIC) or (6) the Air Intercept Controller Supervisor (AICS). On larger ships, the AICS supervises each of a number of AICs. The smaller ships may have only one AIC and no need for a supervisor. The AIC is the only person in this organization who communicates directly with (12) the aircrews (A/C).

Other personnel in this network who communicate with the AIC can include (9) the track supervisor, who has radar, communications, and an assortment of special tracker and PIRAZ (Primary Identification Radar Advisory Zone) information available to him; (10) the assistant AIC, who monitors the AC net, who relays state and status reports to homeplate via the AC talker, who logs important aspects of the tactical situation in the AIC log, and who assists with TAO/SWC liaison; and (7) the Electronic Warfare (EW) personnel, who can provide information about Electronic Counter Measures (ECM). The AIC can also contact (11) other AICs for coordination and (13) the aircraft's parent carrier (homeplate) for handovers.

AIC Duties

The main tasks of the AIC are (1) to collect data about the air warfare tactical situation in regard to his assigned aircraft and (2) to transmit that data, as necessary, to the A/C and the TAO. In this way the AIC can project a constantly updated picture of the tactical air warfare arena to the aircrew, who must live in that environment, and to the TAO, SWC, and AW, who must command that environment.

ACE STUDENT GUIDE  
AIC's Job Description (A)

As the AIC comes to his watch station each day, he must be aware of the missions his aircraft will be carrying out, the rules of engagement limiting the situation, the present tactical situation, and the special operation code words applying to the day's activities. To gain this information the AIC consults operation orders, status boards, message boards, charts, rules of engagement, and CIC personnel.

Often the AIC has an assistant AIC and/or trackers assigned to him. Before he starts work, if possible, the AIC should brief these personnel concerning the type of help he wants from them.

Sometimes the AIC will relieve another AIC while a combat air patrol (CAP) is in the air, on station, or even during a tanking. Most often, however, the AIC will be scheduled onto a console a half hour before flights are scheduled.

Generally, when a new CAP is sent up, the CAP is initially controlled by an Aircraft Controller (AC) on the ship from which the CAP is launched. In order for the AIC to obtain control, the CAP must be handed over, normally using data link. This is a simple process and, upon acceptance of the handover, the AIC becomes the aircrew's communications link.

Now the AIC's job becomes one of maintaining a constant surveillance of the tactical situation in regard to his CAP(s). As the tactical situation changes, the type and amount of information needed by the A/C and the TAO also change. The AIC is responsible for getting and relaying that information in an accurate and timely manner.

It is interesting to note at this point that from one perspective the Air Intercept Controller does not really control anything! The pilot is solely responsible for his aircraft, and the AIC "commands" might be strictly considered "recommendations." In practice, however, the AIC's instructions and advisories have direct impact on the aircraft and tactical situation. The AIC transmits a picture of the tactical environment and TAO/SWC/AW commands to the A/C and relays state and status data to the TAO/SWC. The AIC also relays the NTDS generated heading for nearest collision intercept or nearest collision intercept conversion (NCI/NCIC) and sends heading advisories for area control, set-ups (for aircrew training), and breakaways; advises the TAO of possibly unrecognized problems; and advises tanker aircraft of rendezvous headings. The AIC usually has no authority to initiate intercepts, to move the aircraft off station, or to command the A/C to adopt a new heading.

ACE STUDENT GUIDE  
Reviewable Segments (Supplement B)

This supplement contains a complete listing of all segments that may be reviewed. To call up this listing, press the ABORT Key and select the review option, then this listing will be shown. You may request any segment that you have previously covered in the regular instructional sequence. (You could not, however, request a segment in Level 8 if you were presently working in Level 3.) When you finish the review segment, you may request another option or return to the regularly scheduled instruction.

\*\*\* REVIEW MENU \*\*\*

You have the following subjects available for review. Please press the NUMBER of your choice, then press ENTER.

0		ESCAPE FROM REVIEW (Return to instruction)
1	145 IAT	Training The Computer (Speech) (Demo)
2	146 IAT	Speech Practice (How To) (Demo)
3	147 IAT	Speech Collection (How To) (Demo)
4	148 IAT	Speech Validation (How To) (Demo)
5	150 IAT	Voice Test (Using This Function) (Demo)
6	160 IAT	Retrain (Using This Function) (Demo)
7	220 IAT	Heading/Bearing and Range To Station (Demo)
8	221 IAT	Tracking The CAP (Demo)
9	222 IAT	Heading To Station (Demo)

[Press NEXT to display additional subjects]  
 You can end a review at any time by entering ABORT.

\*\*\* REVIEW MENU \*\*\*

You have the following subjects available for review. Please press the NUMBER of your choice, then press ENTER.

0		ESCAPE FROM REVIEW (Return to instruction)
1	223 IAT	Bearing And Range To Station (Demo)
2	250 FP	Enroute To Station (Prac)
3	230 IAT	Heading/Bearing And Range To Bogey (Demo)
4	231 IAT	Vectoring To Bogey (Demo)
5	232 IAT	Bogey Bearing And Range (Demo)
6	233 IAT	Bogey Track And Ground Speed (Demo)
7	251 FP	Enroute To Station/Intercept Init. (Prac)
8	374 IAT	Preparation/Enroute To Station (Demo)
9	375 IAT	Console Set-Up/Enter CAP Symbol (Demo)

[Press NEXT to display additional subjects]  
 You can end a review at any time by entering ABORT.

## ACE STUDENT GUIDE

Reviewable Segments (Supplement B)

## \*\*\* REVIEW MENU \*\*\*

You have the following subjects available for review. Please press the NUMBER of your choice, then press ENTER.

0		ESCAPE FROM REVIEW (Return to instruction)
1	376 IAT	Establish Communications (Demo)
2	377 IAT	Locate CAP (Demo)
3	378 IAT	Update CAP Symbol (Demo)
4	379 IAT	Enroute To Station (Demo)
5	330 IAT	Offsetting Ownship (Why) (Demo)
6	331 IAT	Symbol Names (Demo)
7	332 IAT	Offsetting Procedure (For Ownship) (Demo)
8	333 IAT	Offsetting PPIRO Procedure (Demo)
9	350 IAT	Engage CAP To Station/Heading (Demo)

[Press NEXT to display additional subjects]  
You can end a review at any time by entering ABORT.

## \*\*\* REVIEW MENU \*\*\*

You have the following subjects available for review. Please press the NUMBER of your choice, then press ENTER.

0		ESCAPE FROM REVIEW (Return to instruction)
1	351 IAT	Bearing And Range To Station (Demo)
2	352 IAT	State Report (Demo)
3	353 IAT	Update NTDS With State (Demo)
4	354 IAT	Report To SWC (Demo)
5	397 FP	Preparation/Enroute To Station (Prac)
6	360 IAT	Intercept Initiation/Runout (Demo)
7	361 IAT	Intercept Initiation (Demo)
8	362 IAT	Intercept Runout (Demo)
9	363 IAT	Bogey On Sequence List (Demo)

[Press NEXT to display additional subjects]  
You can end a review at any time by entering ABORT.

## ACE STUDENT GUIDE

Reviewable Segments (Supplement B)

## \*\*\* REVIEW MENU \*\*\*

You have the following subjects available for review. Please press the NUMBER of your choice, then press ENTER.

0		ESCAPE FROM REVIEW (Return to instruction)
1	364 IAT	Interpreting CAP Calls (Demo)
2	398 FP	Runout (Prac)
3	370 IAT	Engagement/Breakaway (Demo)
4	371 IAT	Engagement (Demo)
5	372 IAT	Interpreting Results (Demo)
6	373 IAT	Reporting Results To SWC (Demo)
7	380 IAT	Engagement/Breakaway Phrases (Demo)
8	399 FP	Engagement/Breakaway (Prac)
9	425 IAT	Bogey Jinks (Demo)

[Press NEXT to display additional subjects]  
You can end a review at any time by entering ABORT.

## \*\*\* REVIEW MENU \*\*\*

You have the following subjects available for review. Please press the NUMBER of your choice, then press ENTER.

0		ESCAPE FROM REVIEW (Return to instruction)
1	426 IAT	Detecting/Calling Jinks (Demo)
2	427 IAT	Countering The Jink (Demo)
3	465 FP	Jinks (Prac)
4	430 IAT	Bogey Splits (Demo)
5	431 IAT	Responding To The Split (Demo)
6	432 IAT	Dealing With The Split (Demo)
7	433 IAT	Dealing With The Platform (Demo)
8	466 FP	Splits (Prac)
9	440 IAT	Multiple Bogeys (Demo)

[Press NEXT to display additional subjects]  
You can end a review at any time by entering ABORT.

ACE STUDENT GUIDE  
Reviewable Segments (Supplement B)

\*\*\* REVIEW MENU \*\*\*

You have the following subjects available for review. Please press the NUMBER of your choice, then press ENTER.

0		ESCAPE FROM REVIEW (Return to instruction)
1	441 IAT	Composition Calls (Demo)
2	442 IAT	Incorrect Contact Calls (Demo)
3	467 FP	Compositon/Contact Calls (Prac)
4	520 IAT	Dealing With Strangers (Demo)
5	524 FP	Strangers (Prac)
6	620 IAT	Rendezvous (Demo)
7	621 IAT	Initial Calculations (Demo)
8	622 IAT	Establish CAP Heading (Demo)
9	623 IAT	Establishing The LSL (Demo)

[Press NEXT to display additional subjects]  
 You can end a review at any time by entering ABORT.

\*\*\* REVIEW MENU \*\*\*

You have the following subjects available for review. Please press the NUMBER of your choice, then press ENTER.

0		ESCAPE FROM REVIEW (Return to instruction)
1	624 IAT	Turning To The LSL (Demo)
2	625 IAT	Transmit And Correct The Turn (Demo)
3	626 IAT	Transm. Before The Rendezvous Turn (Demo)
4	627 IAT	Establishing Geom. For The Turn (Demo)
5	628 IAT	Final Transmissions (Demo)
6	650 FP	Performing A Rendezvous (Prac)
7	725 IAT	Radar Fades (Demo)
8	727 IAT	After The "In The Dark" Call (Demo)
9	770 FP	Radar Fades (Prac)

[Press NEXT to display additional subjects]  
 You can end a review at any time by entering ABORT.

## ACE STUDENT GUIDE

Reviewable Segments (Supplement B)

## \*\*\* REVIEW MENU \*\*\*

You have the following subjects available for review. Please press the NUMBER of your choice, then press ENTER.

0		ESCAPE FROM REVIEW (Return to instruction)
1	730 IAT	NTDS Failure (Demo)
2	731 IAT	Responding To The NTDS Failure (Demo)
3	732 IAT	NTDS Down/Bearing And Range Calls (Demo)
4	733 IAT	Dead Reckoning (W/out NTDS Or Radar) (Demo)
5	771 FP	NTDS Down (Prac)
6	773 FP	Super Practice (I) Tac. Env. (Prac)
7	774 FP	Super Practice (II) Tac. Env. (Prac)
8	772 FP	Emergency (Prac)
9	880 IAT	Training Setups (Demo)

[Press NEXT to display additional subjects]  
You can end a review at any time by entering ABORT.

## \*\*\* REVIEW MENU \*\*\*

You have the following subjects available for review. Please press the NUMBER of your choice, then press ENTER.

0		ESCAPE FROM REVIEW (Return to instruction)
1	881 IAT	Head-On Intercepts (Demo)
2	822 IAT	Tail-To-Tail Intercepts (Demo)
3	823 IAT	Area Control (Demo)
4	824 IAT	Initiate Breakaway (Demo)
5	825 IAT	Equal Distance Runouts/Out Of Corners (Demo)
6	826 IAT	Enroute To Area (Demo)
7	827 IAT	Enroute To Area/Checkin (Demo)
8	828 IAT	Lost Communications (Demo)
9	829 IAT	Detach Wingman (Demo)

[Press NEXT to display additional subjects]  
You can end a review at any time by entering ABORT.

## ACE STUDENT GUIDE

Reviewable Segments (Supplement B)

## \*\*\* REVIEW MENU \*\*\*

You have the following subjects available for review. Please press the NUMBER of your choice, then press ENTER.

0		ESCAPE FROM REVIEW (Return to instruction)
1	870 FP	From Preparation To Judy (Prac)
2	830 IAT	Adjusting The Target Aspect Angle (Demo)
3	831 IAT	Est. Separation With Known Ranges
4	871 FP	Running Super Setups, Set 1 (Prac)
5	872 FP	Running Super Setups, Set 2 (Prac)
6	873 FP	Super Setups, Set 1 (Prac)
7	874 FP	Super Setups, Set 2 (Prac)
8	875 FP	Super Setups, Set 3 (Prac)
9	876 FP	Super Setups, Set 4 (Prac)

[Press NEXT to display additional subjects]

You can end a review at any time by entering ABORT.

## \*\*\* REVIEW MENU \*\*\*

You have the following subjects available for review. Please press the NUMBER of your choice, then press ENTER.

0		ESCAPE FROM REVIEW (Return to instruction)
1	877 FP	Super Setups, Set 5 (Prac)
2	878 FP	Super Setups, Set 6 (Prac)
3	879 FP	Super Setups, Set 7 (Prac)

[Press NEXT to display additional subjects]

You can end a review at any time by entering ABORT.

ACE STUDENT GUIDE  
AIC Training Vocabulary (Supplement C)

Introduction

This supplement contains a complete listing of all of the phrases which:

- you will use during the practice exercises of the ACE course
- you must train the system to recognize you saying.

Speech training tips explaining when and how to use this listing to improve the system's recognition of your voice are also provided. It is recommended that you use these tips along with the "Rules for Good Speech Recognition" provided in Subsection III A of this guide.

Phrase Listing

The following listing of phrases contains some overlapping of items. For example:

Item #30 contains port, starboard, and vector, which overlaps with items #31, 32, and 33.

This is done so that if you wish to retrain the system on related phrases (or parts of one phrase), you can select one number and have all of the necessary retraining to occur. These "combination" items are marked with an asterisk (\*).

AIC Training Phrases

0. Zero
1. One
2. Two
3. Three
4. Four
5. Five
6. Six
7. Seven
8. Eight
9. Nine
10. Ten
11. Eleven
12. Twelve
13. Thirteen
14. Fourteen
15. Fifteen
16. Sixteen
17. Seventeen
18. Eighteen
19. Nineteen

## ACE STUDENT GUIDE

AIC Training Vocabulary (Supplement C)

20. Twenty
21. Thirty
22. Forty
23. Fifty
24. Sixty
- \*25. Digits (0-9) as a group
- \*26. 10-19 as a group
- \*27. 20, 30, 40, 50, 60
28. Crackerjack #1
29. Silver Hawk #2
- \*30. C/S; P/S/V XXX
31. C/S; Port XXX
32. C/S; Starboard XXX
33. C/S; Vector XXX
34. C/S; P/S/V XXX; For Bogey
35. Station XXX; YY
36. Bogey XXX; YY
- \*37. Bogey Tracking XXX; Speed Point X
38. Bogey Tracking XXX; Speed Point X
39. Bogey Tracking XXX; Speed Point X
40. C/S(;) Mark your TACAN
41. C/S(;) What State?
42. Roger State XXX
43. C/S; State XXX
44. I Have Control of C/S
45. C/S(;) On Station
46. C/S(;) Breaking Away
- \*47. Splash/Heads-up 1/2 Bogey(s)
48. Splash One Bogey
49. Heads-up Two Bogey(s)
50. Splash One Bogey
51. Heads-up Two Bogeys
- \*52. Bogey(s) Single/Multiple Altitude Y Thousand
53. Bogey Single Altitude Y Thousand
54. Bogeys Multiple Altitude Y Thousand
55. Bogey Single Altitude Y Thousand
- \*56. Bogey Jinking Left/Right
57. Bogey Jinking Left
58. Bogey Jinking Right
59. Bogey Splitting
- \*60. Roger; Bogey Tracking XXX
- \*61. Negative; Bogey XXX; YY
62. Stranger XXX; YY
63. Stranger Tracking XXX; Angels Y
64. Stranger Opening
- \*65. C/S(;) Tighten Turn/Ease Turn
66. C/S(;) Tighten Turn
67. C/S(;) Ease Turn

## ACE STUDENT GUIDE

AIC Training Vocabulary (Supplement C)

- 68. C/S(;) Radio Check Over
- \*69. Bogey/Fighter in the Dark
- 70. Bogey in the Dark
- 71. Fighter in the Dark
- 72. C/S(;) My Octopus is Bent
- 73. C/S(;) Emergency
- 74. C/S; P/S/V XXX; For Rendezvous
- \*75. C/S; Detach Port/Detach Starboard XXX; For Separation
- 76. C/S; Detach Port XXX; For Separation
- 77. C/S; Detach Starboard XXX; For Separation
- 78. C/S; Detach P/S XXX; For Separation
- 79. C/S; Continue XXX
- 80. C/S; Breakaway XXX
- 81. C/S(;) Angels Y
- \*82. C/S; C/S XXX; YY
- 83. C/S(;) Steady
- 84. C/S(;) Lost Communications Intentions
- 85. Roger Lost Comm
- 86. C/S; P/S/V XXX; As Bogey
- 87. Roger
- 88. Negative
- 89. Say Again
- 90. Correction
- 91. AIC 1

NOTE: Voice data are collected for underlined phrases only (except for elements 0-27, which are all collected).

Speech Training Tips

If a phrase is being unrecognized (the system does not consistently react as if a particular phrase has been said whenever that phrase is said or it gives no response), then:

- Retrain only the misunderstood phrase. Use the number for that phrase only. Example:

Only "Roger" in "Roger State XXX" is misunderstood. Use item #90 and retrain the system on "Roger" rather than item #42 ("Roger State XXX").

- If the phrase is misrecognized (the system consistently reacts to the phrase said as if another one has been transmitted) retrain both phrases. Example:

"On Station" is confused by the system with "Breaking Away." Use both items #45 and 46 for retraining the system.

ACE STUDENT GUIDE

AIC Training Vocabulary (Supplement C)

- Use the "combination" items (marked with \*) for retraining only if all parts of the transmission are not being recognized properly. Otherwise, you run the risk of substituting a voice collection that works for one that may or may not work.

Voice Test

The INIT VOICE TEST command is one of the most important commands you have available. Use this command regularly throughout each day you're using the system. Use it to check the system's recognition of your voice. If you find that the system is not recognizing you as well as it should, use the "RETRAIN" function as needed to improve recognition.

Reminder

Regularly review the "Rules for Good Speech Recognition" listed in Subsection III A. Follow these rules to keep the system's recognition of your voice at an acceptable level.

## ACE STUDENT GUIDE

Abort Menu (Supplement D)Menu Options

When the "ABORT" command is entered into the ACE system, you will see a menu on the Student Station CRT which lists your current options. This menu is shown below.

```

                                ABORT MENU

Your Options At This Time Are To:

    0 Continue With The Instruction
    1 End This Session With ACE
    2 Review A Previous Subject
    3 See Your Current Course Information

Press The NUMBER of Your Choice: ___, Then Press ENTER.

```

Option "0"

If you select option "0" on the menu, you will return to the beginning of the lesson or exercise you were in when you entered the "ABORT" command.

Option "1"

If you select option "1" on the menu, you will sign off the system. However, you return to the instruction at the beginning of the next regularly scheduled lesson or exercise of the course.

Option "2"

If you select option "2" on the menu, you will see the Review Menu on the CRT. The Review Menu is shown in the following illustration.

```

                                REVIEW MENU

You have the following subjects available for review. Please
press the NUMBER of your choice: ___, then press ENTER.

    0   Escape From Review (Return To Instruction)
[ <no.> <Review Title> ]
[ <no.> <Review Title> ]
.
.
.
[Press "NEXT" to display additional subjects ]
You can end a review at any time by entering "ABORT".

```

NOTE: Entering "ABORT" during a review will send you back to the beginning of the lesson or exercise you were in when you requested the review (or the next regularly scheduled piece of instruction, if there is a difference).

## ACE STUDENT GUIDE

Abort Menu (D)Option "3"

If you select option "3" on the menu, you will see a "Current Course Information" menu. The options on this menu allow you to see data about your work (to date) in the course. These options are shown in the following illustration of this menu.

## CURRENT COURSE INFORMATION

You can see:

0. Continue With The Instruction
1. Your Current Course Position
2. The Score For Your Last Practice Without Freezes
3. Your Progress Through The Course

Press the NUMBER of your choice: \_\_\_, then press ENTER.

Current Course Information

If you select option "0" on this menu, you will be returned to the instruction just as you would be if you had selected option "0" on the ABORT menu.

Current Course Position

If you select option "1" on this menu, you will see the following data displayed:

## CURRENT COURSE POSITION

At this time you have completed the instruction for

Segment: [No., Type\*, Name]  
 Unit No.: [ ]  
 Level No.: [ ]

\*Note: The ACE system uses the following acronyms for "lesson" and "practice exercises":

Lesson = IAT  
 Practice with Error Freezes = CP  
 Practice without Freezes = FP

The term "segment" refers to a lesson or exercise.

Suggested Uses

To use the information offered with the "Current Course Position" display, locate the number of the level shown on the screen in Section V of this guide

## ACE STUDENT GUIDE

Abort Menu (D)

(Level 1 = Subsection V A, 2 = V B, etc.). Then within the correct subsection, locate the unit number shown on the screen. The diagram for each unit will help you locate the number and name of the segment shown on the screen. You can then review the guide to see what lessons and practice exercises are ahead of you in the unit, level or course.

Score for Last Practice

If you select option "2" on the Current Course Information menu, you will see the following:

LAST PRACTICE EXERCISE SCORE				
Your last practice exercise was:				
[No., Name]				
During that exercise your scores on the PMVs were as follows:				
Name	Pass/Fail	Score	Passing Score	Action

Note: This information is only offered for your last completed Practice without Freezes exercise.

Suggested Uses

The information shown on the CRT can be used to determine, for each exercise requirement:

- its name (this can then be used to locate the description of the requirement under "What You'll be Expected to Do" in the appropriate level's subsection of Section V)
- if you passed or failed it
- the total number of points (out of 100) that you earned
- the passing score set for this exercise
- the action taken by the system as a result of your performance.

The system, for any exercise requirement can:

- pass you
- give you remediation (review of instruction to help you correct your problem)
- send you to the instructor for help.

Course Progress

Selecting option "3" on the Current Course Information Menu will provide you with the following display:

## ACE STUDENT GUIDE

Abort Menu (Supplement D)

## COURSE PROGRESS

Starting At The Beginning, This Shows You How You Have Progressed Through The Course.

Path	Seg.	Entry	Exit	Time	Inst.		
No.	Date	No.	Type	Mode	Mode	Spent	Call?

Suggested Uses

This display will give you the following information:

- path number - these numbers show the order in which you went through the pieces of instruction (lessons or practice exercises) in this course
- date - the date on which you entered the lesson or exercise
- time - the time on the date shown in which you entered the lesson or exercise
- segment number - the number assigned to the lesson or exercise (these same numbers are used in the level diagrams in Subsections V A through H)
- type - the type of instruction you received:
  - IAT = Lesson
  - CP = Practice with Error Freezes
  - FP = Practice without Freezes
- entry mode - the way you entered the lesson or exercise:
  - CHAL-FAIL (failed challenge)
  - CHAL-SUCC (passed challenge)
  - OVERR-ADV (advanced with instructor override)
  - OVERR-RPT (sent to review old instruction with instructor override)
  - REVIEW (you requested review of old instruction)
  - REMED (system sent you for help - with review of instruction on a skill weakness)
  - NORMAL (next regularly scheduled instruction)
  - SEG-CHAL (you challenged an objective)
- exit mode - the way in which you left the instruction:
  - CHAL-SUCC
  - CHAL-FAIL
  - OVERR-ADV
  - OVERR-RPT
  - REMED
  - ABORT (you entered "ABORT")
  - INSTRUC REF (you or the system called the instructor to come assist you)
  - NORMAL
  - SEG-CHAL

ACE STUDENT GUIDE

Abort Menu (Supplement D)

- time spent - how long you were in the lesson or exercise
- inst. call? (Was the instructor called?)
  - NO
  - SYS (yes, the system called him)
  - STU (yes, you, the student, called him)
  - BOTH (yes, both the student and the system requested help.)

ACE STUDENT GUIDE  
AIC Messages (Supplement E)

Introduction

The following listing includes all of the transmissions you will hear made by the system's AIC voice. You will hear these calls:

- during demonstrations (accompanied by TV screen presentations) of how to perform a job
- when you are practicing new voice calls, training the system to recognize you saying them, or checking the system's recognition of your voice.

Message Listing

ROGER  
 SAY AGAIN  
 CORRECTION  
 C/S; PORT XXX  
 C/S; STARBOARD XXX  
 C/S; VECTOR XXX  
 C/S; PORT XXX; FOR BOGEY  
 C/S; STARBOARD XXX; FOR BOGEY  
 C/S; VECTOR XXX; FOR BOGEY  
 STATION XXX; YY  
 BOGEY XXX; YY  
 BOGEY TRACKING XXX; SPEED POINT M  
 C/S(;) MARK YOUR TACAN  
 C/(S); WHAT STATE?  
 ROGER; STATE XXX  
 C/S; STATE XXX (TO SWC)  
 I HAVE CONTROL OF C/S (TO SWC)  
 C/S(;) ON STATION  
 C/S(;) BREAKING AWAY (TO SWC)  
 SPLASH, ONE/TWO BOGEY(S) (TO SWC)  
 HEADS-UP; ONE/TWO BOGEY(S) (TO SWC)  
 BOGEY SINGLE ALTITUDE Y THOUSAND  
 BOGEYS MULTIPLE ALTITUDE Y THOUSAND  
 BOGEY JINKING LEFT  
 BOGEY JINKING RIGHT  
 BOGEY SPLITTING  
 ROGER; BOGEY TRACKING XXX  
 NEGATIVE; BOGEY XXX; YY  
 STRANGER XXX; YY  
 STRANGER TRACKING XXX; ANGELS Y  
 STRANGER OPENING  
 C/S(;) TIGHTEN TURN  
 C/S(;) EASE TURN  
 C/S(;) RADIO CHECK OVER  
 BOGEY IN THE DARK

ACE STUDENT GUIDE  
AIC Messages (Supplement E)

FIGHTER IN THE DARK  
C/S(;) MY OCTOPUS IS BENT  
C/S(;) EMERGENCY (TO SWC)  
C/S; PORT XXX, FOR RENDEZVOUS  
C/S; STARBOARD XXX; FOR RENDEZVOUS  
C/S; VECTOR XXX; FOR RENDEZVOUS  
C/S; DETACH PORT XXX; FOR SEPARATION  
C/S; DETACH STARBOARD XXX; FOR SEPARATION  
C/S; CONTINUE XXX  
C/S; BREAKAWAY XXX  
C/S; ANGELS Y  
C/S; C/S XXX; YY  
C/S(;) STEADY  
C/S(;) LOST COMMUNICATIONS INTENTIONS  
ROGER LOST COMM  
C/S; PORT XXX; AS BOGEY  
C/S; STARBOARD XXX; AS BOGEY  
C/S; VECTOR XXX; AS BOGEY  
AIC1 (TO SWC)  
BOGEY TRACKING XXX  
EMERGENCY XXX; YY

Suggested Uses

This listing makes it possible for you to look up a phrase you thought you heard (but were unsure of) in a demonstration. You can determine if it is possible for that phrase to have been said. If it could not have been said, you may wish to review the demonstration and recheck the transmission.

ACE STUDENT GUIDE

Team Member Messages (Supplement F)

Introduction

The following listing includes all of the transmissions you will hear made by the system's CAP, SWC, pseudo-bogey or MAC voices. You will hear these calls:

- during demonstrations (accompanied by TV screen presentations) of how to perform a job
- when you are working in a practice exercise and you are responding to the calls of team members (or they are responding to yours).

CAP Messages

RUTH THIS IS SILVER HAWK ON MIRAMAR'S XXX YY, ANGELS ZZ, HEADING XXX, OVER  
RUTH THIS IS SILVER HAWK ON MIRAMAR'S XXX YY, CRACKERJACK, ANGELS ZZ, HEADING  
XXX, OVER  
LOOKING  
VISUAL  
CONTACT XXX YY  
JUDY  
LOST CONTACT  
TALLY HO, FOX 1, BREAKAWAY  
HEADS-UP Y BOGEY(S)  
SPLASH Y BOGEY(S)  
RENDEZVOUS POINT WHISKEY, ANGELS ZZ  
ROGER XXX  
STATE FFF  
ROGER EASE TURN  
ROGER TIGHTEN TURN  
XXX, YY (RESPONSE TO TACAN REQUEST)  
REQUEST RENDEZVOUS WITH CRACKERJACK  
FAMISHED  
REQUEST BOGEY DOPE ON PLATFORM  
ROGER  
SAY AGAIN  
JUDY, FOX 1, BOGEY DOPE ON PLATFORM  
REQUEST BREAKAWAY HEADING  
STRANGER OPENING

SWC Messages

WHAT STATE  
UPDATE SYMBOLS  
RESULTS OF INTERCEPT  
BREAKAWAY REPORT  
SILVER HAWK AIRBORNE FOR CONTROL

ACE STUDENT GUIDE

Team Member Messages (Supplement F)

SWC AYE  
THANK YOU  
VERY WELL  
SAY AGAIN  
STATE BEARING AND RANGE FROM OWNERSHIP TO EMERGENCY

Pseudo-Bogey/MAC Messages

ROGER  
ROGER XXX  
STATE FFF  
ROGER EASE TURN  
ROGER TIGHTEN TURN  
XXX, YY (RESPONSE TO TACAN REQUEST)  
SAY AGAIN

Suggested Uses

These listings make it possible for you to look up a phrase you thought you heard (but were unsure of) in a demonstration or exercise. You can determine if it is possible for that phrase to have been said. If it could not have been said, you may wish to review the demonstration in question (or, in the case of a practice exercise, review the demonstration or instruction related to the situation in which you received the call).

NAVTRAEQUIPCEN 78-C-0182-10

DISTRIBUTION LIST

Commanding Officer  
Naval Training Equipment Center  
Orlando, FL 32813 18

Defense Technical Information Center  
Cameron Station  
Alexandria, VA 22310 12