

AD-A 107 037

TECHNICAL  
LIBRARY

AD A-107037

TECHNICAL REPORT ARBRL-TR-02370

EFFECTIVENESS TESTING FOR ANTIPROPAGATION  
SHIELDS DEVELOPED FOR M456  
HEAT TANK AMMUNITION

Jerry Thomas  
Philip M. Howe

September 1981



**US ARMY ARMAMENT RESEARCH AND DEVELOPMENT COMMAND**  
**BALLISTIC RESEARCH LABORATORY**  
ABERDEEN PROVING GROUND, MARYLAND

Approved for public release; distribution unlimited.

Destroy this report when it is no longer needed.  
Do not return it to the originator.

Secondary distribution of this report by originating  
or sponsoring activity is prohibited.

Additional copies of this report may be obtained  
from the National Technical Information Service,  
U.S. Department of Commerce, Springfield, Virginia  
22151.

The findings in this report are not to be construed as  
an official Department of the Army position, unless  
so designated by other authorized documents.

*The use of trade names or manufacturers' names in this report  
does not constitute indorsement of any commercial product.*



TABLE OF CONTENTS

	Page
LIST OF ILLUSTRATIONS . . . . .	5
I. INTRODUCTION. . . . .	7
II. TEST CRITERIA AND EXPERIMENTAL TECHNIQUE. . . . .	7
III. STATISTICAL DESIGN. . . . .	10
IV. RESULTS . . . . .	11
V. CONCLUSIONS . . . . .	11
APPENDIX. . . . .	13
DISTRIBUTION LIST . . . . .	45

LIST OF ILLUSTRATIONS

Figure	Page
1. Typical Test Setup. . . . .	8
2. Method of Detonation of Donor M456, 105 mm HEAT-T H.E. Projectile, Comp B Loaded with Fuze . . . . .	9
3. Summary of Test Results . . . . .	12

## I. INTRODUCTION

In previous work, conducted for the M1 Tank Project Office (then the XM1), it was demonstrated that detonation of nearest neighbor rounds as a result of detonation of a donor round could be prevented for M456 HEAT warheads by use of polyethylene bars emplaced between each round<sup>1</sup>. While numerous tests demonstrated the effectiveness of the plastic bars, and the thicknesses used contained a considerable margin of safety, the reliability and associated confidence level were unknown. In this effort, we describe a statistical design and tests which were performed to establish the shielding thickness needed to be 90% confident that the probability of a second round detonating, given the detonation of a first round, was less than 0.1.

## II. TEST CRITERIA AND EXPERIMENTAL TECHNIQUE

The criterion for successful shielding was that the acceptor rounds not detonate. Thus, reactions of severity less than that of a design-mode detonation, although not necessarily desirable, were considered acceptable. The basis for this choice was the fact that reactions less severe than detonations will not cause further rounds to detonate, and the process of propagation from round-to-round ceases<sup>2</sup>.

A typical test set up is shown in Figure 1. The donor round was deliberately detonated using a small charge of C-4 explosive, an RDX booster, and P-3 detonating cord as the initiator. The method of initiation is shown schematically in Figure 2. Shielding thicknesses were varied from test to test, according to the design methodology. Shields were fabricated from sheets of polyethylene of various thicknesses, e.g., a 2.54 cm thick shield was fabricated from two 1.27 cm thick slats, and a 1.59 cm thick shield was fabricated from a 1.27 cm thick slat in contact with a 0.32 cm thick slat. Especial care was taken to insure that the donor and acceptor rounds were in contact with the shielding material. Thus, when shielding thickness was varied, spacing between rounds was varied correspondingly. (This represents a more severe testing case than if the spacing were kept constant.) Tests which involved more than two acceptors had 1.27 cm mild steel plates emplaced between them to prevent cross talk between acceptors in the event that one detonated (see the data sheet for test KAA0331A1, in the Appendix, for a schematic).

Photographs were taken of each test before and after deliberate detonation of the donor round. The response of the acceptor rounds was evaluated by examination of the acceptor fragments (when found) and by examination of the witness plates. Both fragment size and witness plates provided unambiguous assessments of munition response. Thus, when acceptors reacted mildly, or not at all, the acceptors were squashed, cracked open, or broken into several very large pieces. The witness plate behind the acceptor (viewed from the donor)

---

<sup>1</sup>Howe, P., "The Phenomenology of Interround Communication and Techniques for Prevention," ARBRL-TR-02048 (1978) (AD #A054373).

<sup>2</sup>This fact has not, as yet, been documented anywhere. It is the conclusion of one of the authors (P. Howe) based on several years of effort in studying propagation mechanisms.

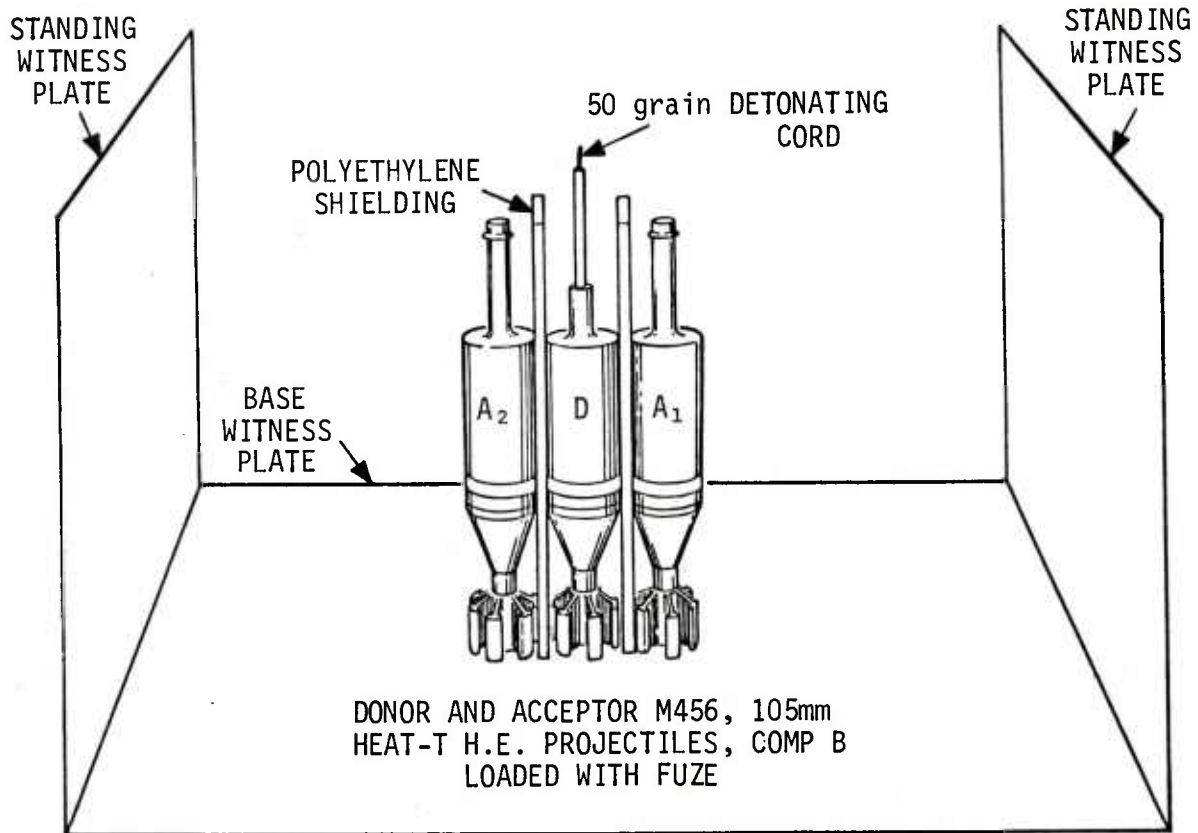

Figure 1 - Typical Test Setup

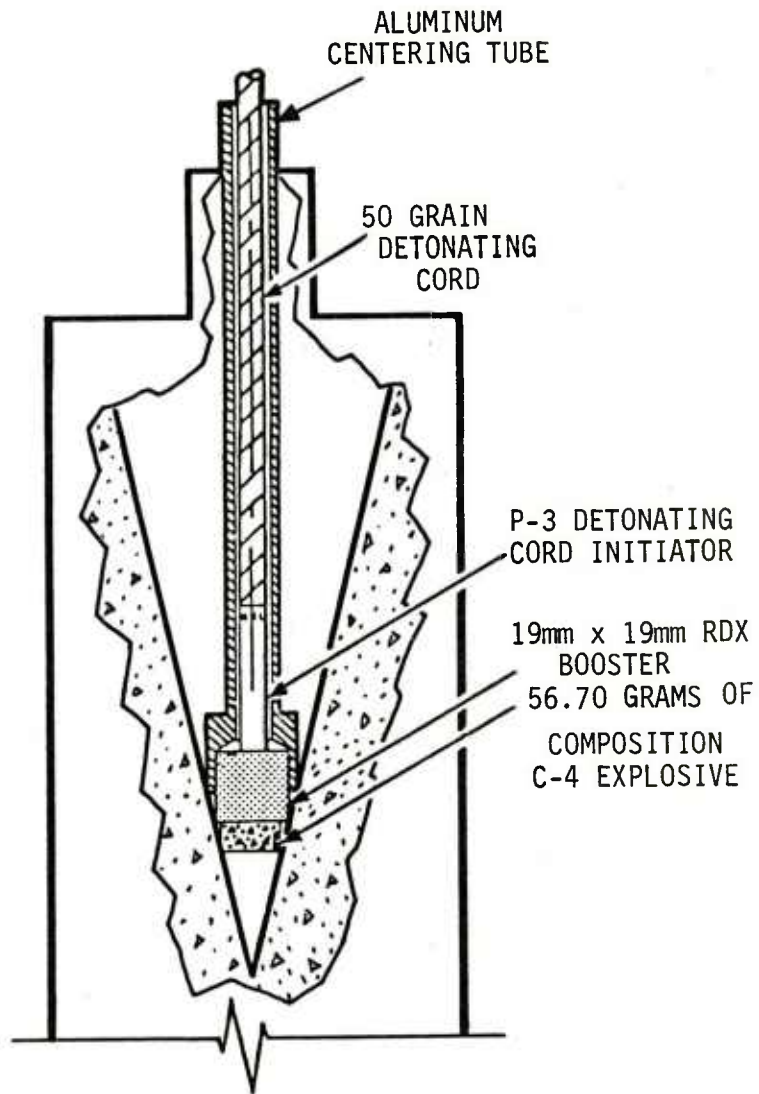

Figure 2 - Method of Detonation of Donor M456, 105 mm HEAT-T H.E. Projectile, Comp B Loaded with Fuze

was frequently coated with explosive. In the regions of the witness plates shadowed from the donor by the acceptors, there were no fragment perforations. This was true both for side witness plates and base witness plates. Compare, for example, the damage to the witness plates in test No. KAA0330E1, where the acceptor round detonated (Appendix, p. 21) and test No. KAA0331A1, where none of the three acceptors detonated (Appendix, p. 23).

### III. STATISTICAL DESIGN

The purpose of the test, as previously stated, was "to establish the shielding thickness needed to be 90% confident that the probability of a second round detonating, given the detonation of a first round, was less than 0.1." Since the probability of interest was  $\alpha = 0.1$ , and is therefore in the tail of some unknown response distribution, the problem appeared to fit into the category of extreme value quantal response designs. Quantal response means that the result has only two possible choices, in this case detonation or nondetonation. Also, because of the lack of information about the response function, a nonparametric test design was used, Modified Alexander Extreme Value (MAEV) Design.

The MAEV design rules are given below. (For more detail, see reference 3.)

1. The first test level is  $X_T$ , the best a priori guess of  $X_\alpha$ .  $X_\alpha$  is the shielding thickness where the probability of a response (detonation) is  $\alpha = 0.1$ .  $\delta = 3.18$  mm is the step size between levels.
2. One acceptor per donor is used, in a decreasing shielding thickness sequence, until a response is observed. Let  $X_d$  be the highest level at which a response is observed.
3. After the first response, the number of acceptors per donor in each test is increased to alternately three and then four. After the first response, three acceptors per donor are tested at the next three levels above  $X_d$ . Then four acceptors per donor having shielding at levels  $X_d$  and the next three higher levels are tested.
4. If another response is observed at a higher level, it becomes  $X_d$ , and testing continues alternating three and then four acceptors per donor until at least 12 (more than half the required 22) nonresponses have been observed at the two levels immediately above  $X_d$ .
5. When at least 12 nonresponses have occurred at  $x_d + \delta$  and  $x_d + 2\delta$ , the number of acceptors per donor is reduced to alternately two above  $X_d$  and then three, starting at  $X_d$ , for the remainder of the test.
6. Testing terminates when at least N (22) nonresponses have been observed at the two levels immediately above the highest level at which a response has been observed.

<sup>3</sup>Smith, J. H. and Thomas, J., "Extreme Value Quantal Response Experimental Design," ARBRL-TR-02325 (1981). (AD #A101188)

The 22 nonresponses were arrived at in the following manner. If the probability of a response at  $X_\alpha$  is equal to  $\alpha$ , then the probability of not getting a response is  $1 - \alpha$ . Assuming the tests are independent, the probability of  $n$  nonresponses in  $n$  tests is  $(1 - \alpha)^n$ . Then,  $1 - (1 - \alpha)^n = P$ , is the probability of at least one response in  $n$  tests. In our case,  $P = 0.9$  and  $\alpha = 0.1$ . Solving for  $n$  and letting  $N = [n] + 1$ , we get  $N = 22$ . Thus, after observing 22 nonresponses at  $X_d + \delta$  and  $X_d + 2\delta$ , we can conclude that the level at which the true probability of response is 0.1 is less than  $X_d + 2\delta$  with ninety percent confidence.

#### IV. RESULTS

A summary of the test results is given in Figure 3. The first test, KAA0330A1, had a shielding of 22.23 mm thick between the acceptor and the donor round. The acceptor did not detonate. The shielding thickness was decreased to 15.88 mm for the second test and to 12.70 mm for the third test with no detonation in either test. The acceptor round detonated on the fourth test with a shielding thickness of 9.53 mm between the acceptor and donor.

In all, 14 tests were conducted using 34 acceptors and 14 donors. No acceptor rounds detonated with shielding thickness greater than 9.53 mm between the acceptor and donor round. Of the six rounds tested with shielding thickness of 9.53 mm, four detonated and two did not detonate.

#### V. CONCLUSIONS

1. It was demonstrated that polyethylene bars between M456 HEAT rounds would prevent detonation of the second round if the bar was thick enough.

2. It was estimated that the probability of a second round detonating, given the detonation of a first round, to be less than 0.1 with 90% confidence if the shielding thickness is 15.88 mm or more.

POLYETHYLENE SHIELDING  
THICKNESS (mm)

ROUND NO.	3.18	6.35	9.53	12.70	15.88	19.05	22.23
KAA0330A1							0
KAA0330B1					0		
KAA0330D1				0			
KAA0330E1			X				
KAA0331A1				0	0	0	
KAA0331B1			X	0	0	0	
KAA0331C1				0	0	0	
KAA0331D1			X	0	0	0	
KAA0331E1				0	0	0	
KAA0331F1			0	0	0		
KAA0331G1				0	0		
KAA0331H1			0	0	0		
KAA0331I1				0	0		
KAA0331J1			X	0	0		

X: DETONATION  
O: NON-DETONATION

Figure 3 - Summary of Test Results

APPENDIX

COMPARTMENTALIZATION SHIELDING TEST

DATA SHEETS AND DAMAGE PHOTOS	Page
KAA0330A1 . . . . .	14
KAA0330B1 . . . . .	16
KAA0330D1 . . . . .	18
KAA0330E1 . . . . .	20
KAA0331A1 . . . . .	22
KAA0331B1 . . . . .	24
KAA0331C1 . . . . .	27
KAA0331D1 . . . . .	29
KAA0331E1 . . . . .	32
KAA0331F1 . . . . .	34
KAA0331G1 . . . . .	36
KAA0331H1 . . . . .	38
KAA0331I1 . . . . .	40
KAA0331J1 . . . . .	42

## COMPARTMENTALIZATION SHIELDING TEST

TEST NO: KAA0330A1

DATE: 30 MARCH 1981 TIME: 1145 MST

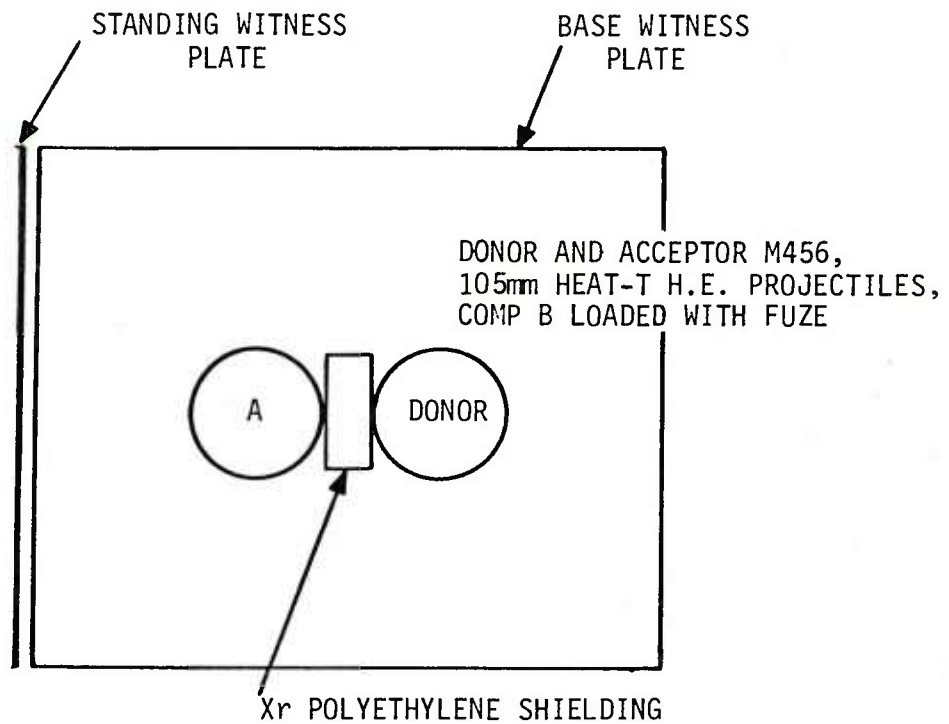

$X_r = 22.23\text{mm}$

(Witness plates are 2.67mm thick mild steel)

RESULTS: Acceptor round did not detonate and was recovered almost intact. The projectile was blown open above the rotating band. The standing witness panel had one large perforation, and unburned explosives were deposited on it. The base witness plate had a tailfin imprint from the detonation of the donor round.

TEST NO: KAA0330A1  
DATE: 30 MARCH 1981



DONOR AND ACCEPTOR  
PROJECTILES BEFORE TEST

ACCEPTOR PROJECTILE  
RECOVERED AFTER  
TEST



# COMPARTMENTALIZATION SHIELDING TEST

TEST NO: KAA0330B1

DATE: 30 MARCH 1981 TIME: 1145 MST

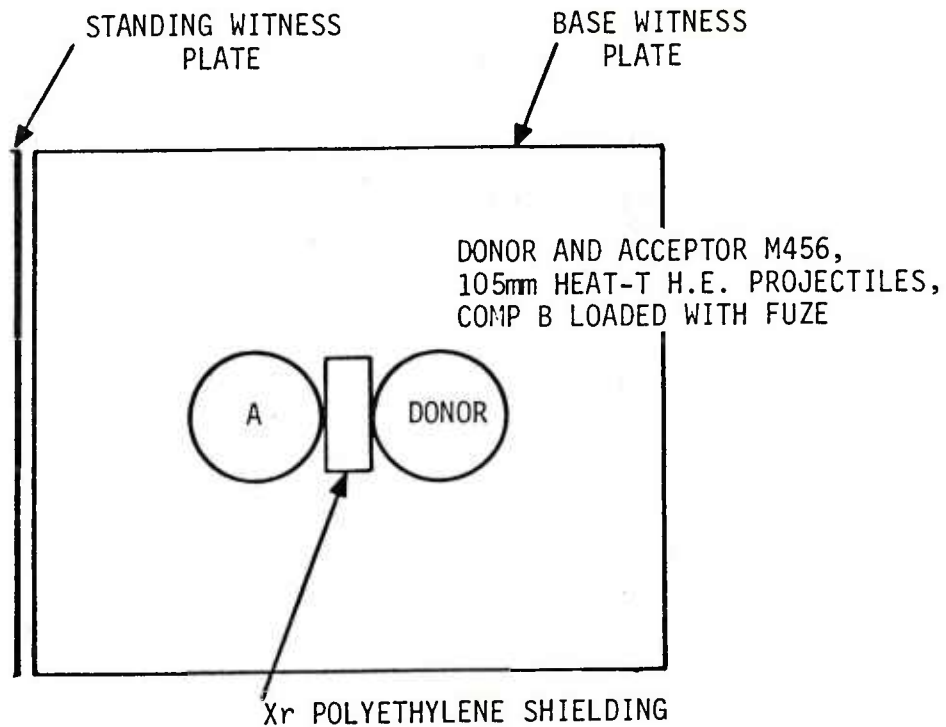

$X_r = 15.88\text{mm}$

(Witness plates are 2.67mm thick mild steel)

RESULTS: Acceptor round did not detonate. A large side fragment and large segment of the boom from the acceptor round were recovered. Several large perforations and unburned and burned explosive were apparent on the standing witness panel. The base witness plate had a tailfin imprint from the detonation of the donor round.



TEST NO: KAA0330B1  
DATE: 30 MARCH 1981

DONOR AND ACCEPTOR  
PROJECTILES BEFORE TEST



FRAGMENTS OF ACCEPTOR PROJECTILE  
RECOVERED AFTER TEST

# COMPARTMENTALIZATION SHIELDING TEST

TEST NO: KAA0330D1

DATE: 30 MARCH 1981 TIME: 1530 MST

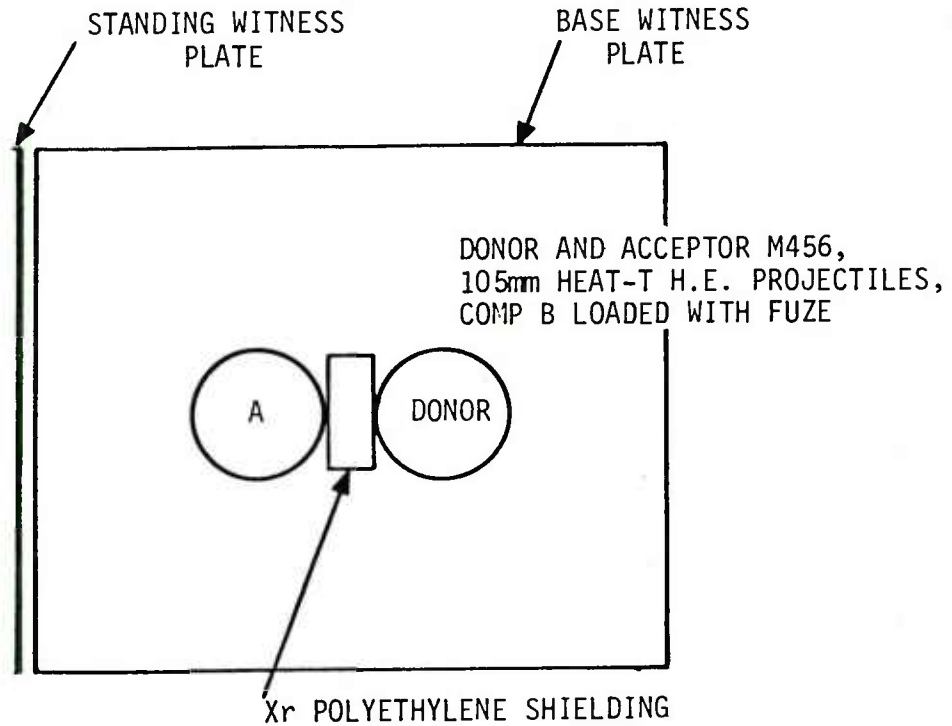

$X_r = 12.70\text{mm}$

(Witness plates are 2.67mm thick mild steel)

RESULTS: Acceptor round did not detonate. The witness panel adjacent to the acceptor round had several large perforations and some unburned H.E. deposited on it. There was a tailfin imprint left on the base witness plate by the detonation of the donor round.



TEST NO: KAA0330D1  
DATE: 30 MARCH 1981

DONOR AND ACCEPTOR  
PROJECTILES BEFORE TEST



FRAGMENTS OF ACCEPTOR PROJECTILE  
RECOVERED AFTER TEST

# COMPARTMENTALIZATION SHIELDING TEST

TEST NO: KAA0330E1

DATE: 30 MARCH 1981 TIME: 1630 MST

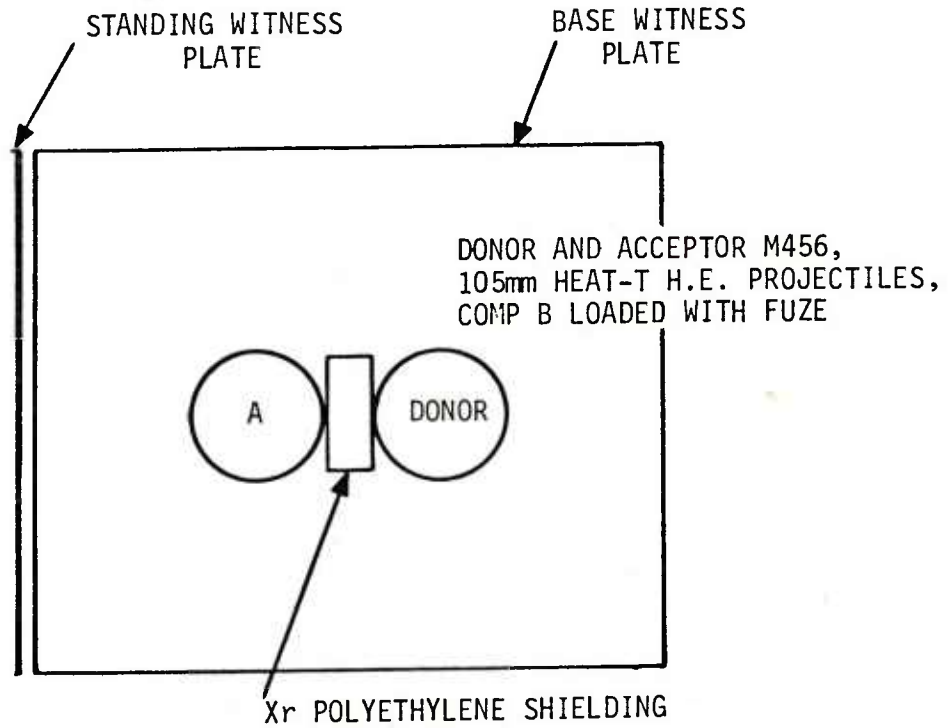

$X_r = 9.53\text{mm}$

(Witness plates are 2.67mm thick mild steel)

RESULTS: Acceptor round detonated. The witness panel had many small perforations in it, but no H.E. was deposited on it. There were two tailfin imprints made in the base witness plate by the detonation of the donor and the acceptor rounds.

TEST NO: KAA0330E1  
DATE: 30 MARCH 1981



DONOR AND ACCEPTOR  
PROJECTILES BEFORE TEST



WITNESS PANEL WHICH STOOD  
ADJACENT TO ACCEPTOR  
PROJECTILE

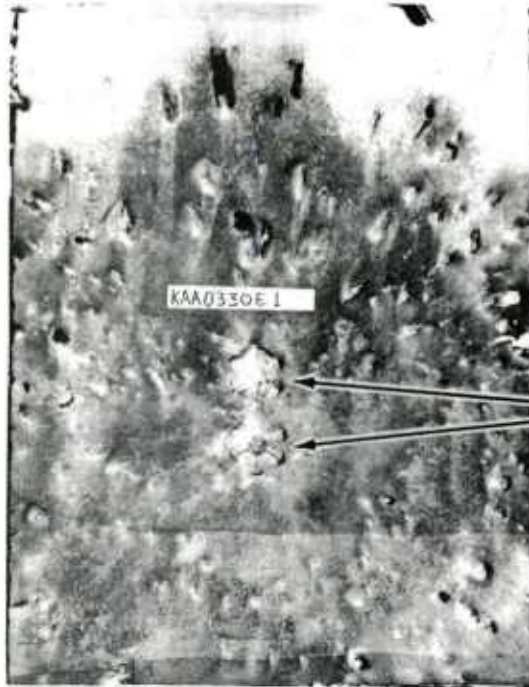

IMPRINTS MADE ON BASE  
WITNESS PLATE BY THE  
DETONATIONS OF THE DONOR  
AND ACCEPTOR PROJECTILES

# COMPARTMENTALIZATION SHIELDING TEST

TEST: KAA0331A1

DATE: 31 MARCH 1981 TIME: 0905 MST

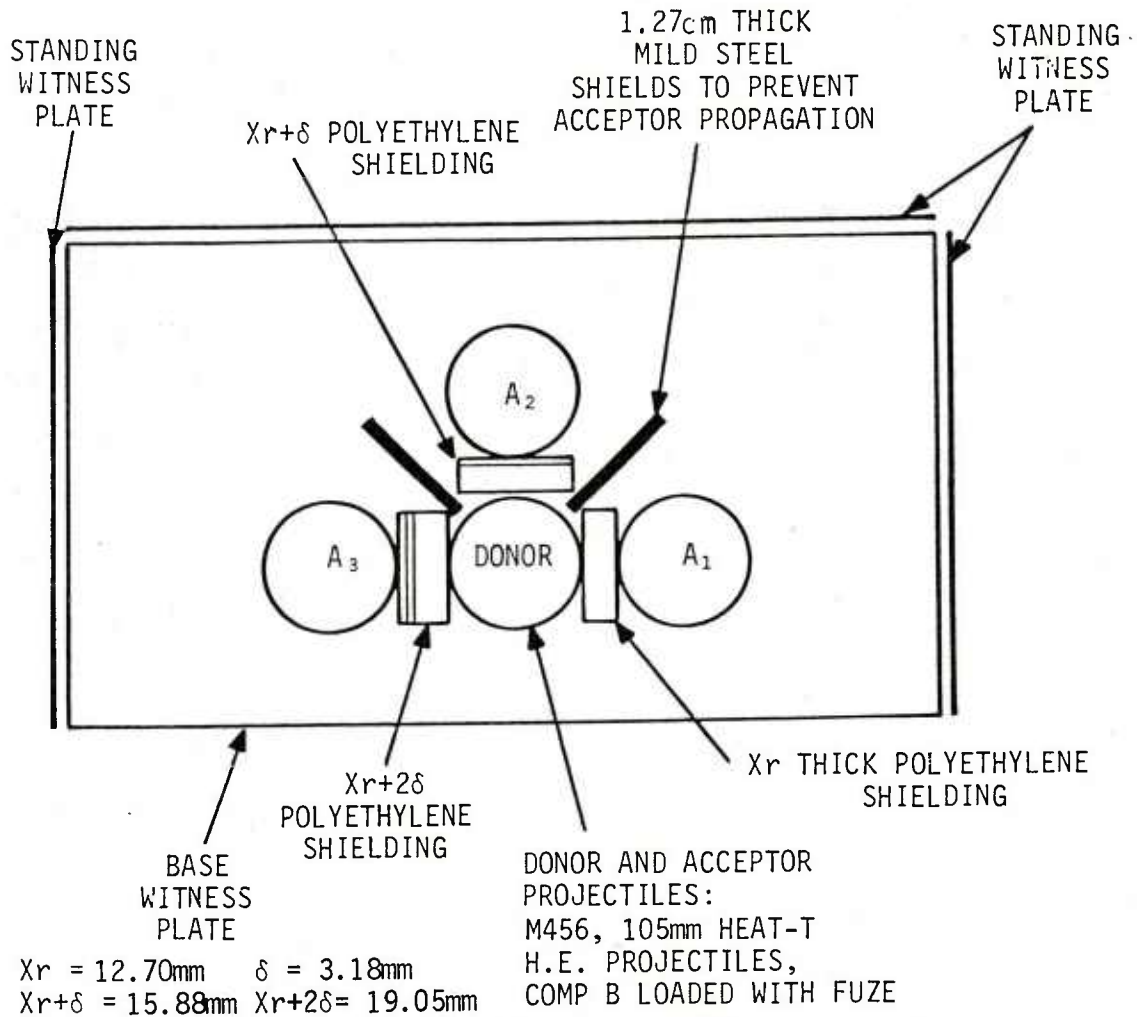

(Witness plates are 2.67mm thick mild steel)

RESULTS: None of the acceptor rounds detonated. The witness panels which were adjacent to the acceptor rounds all had several large perforations. Unburned H.E. was deposited on the witness panels adjacent to  $A_2$  and  $A_3$ , but no H.E. remained on the witness panel adjacent to  $A_1$ .

TEST NO: KAA0331A1  
DATE: 31 MARCH 1981



DONOR AND ACCEPTOR  
PROJECTILES BEFORE TEST

FRAGMENTS OF ACCEPTOR  
PROJECTILES RECOVERED  
AFTER TEST



BASE WITNESS PLATE  
AFTER TEST

# COMPARTMENTALIZATION SHIELDING TEST

TEST: KAA0331B1

DATE: 31 MARCH 1981

TIME: 1000 MST

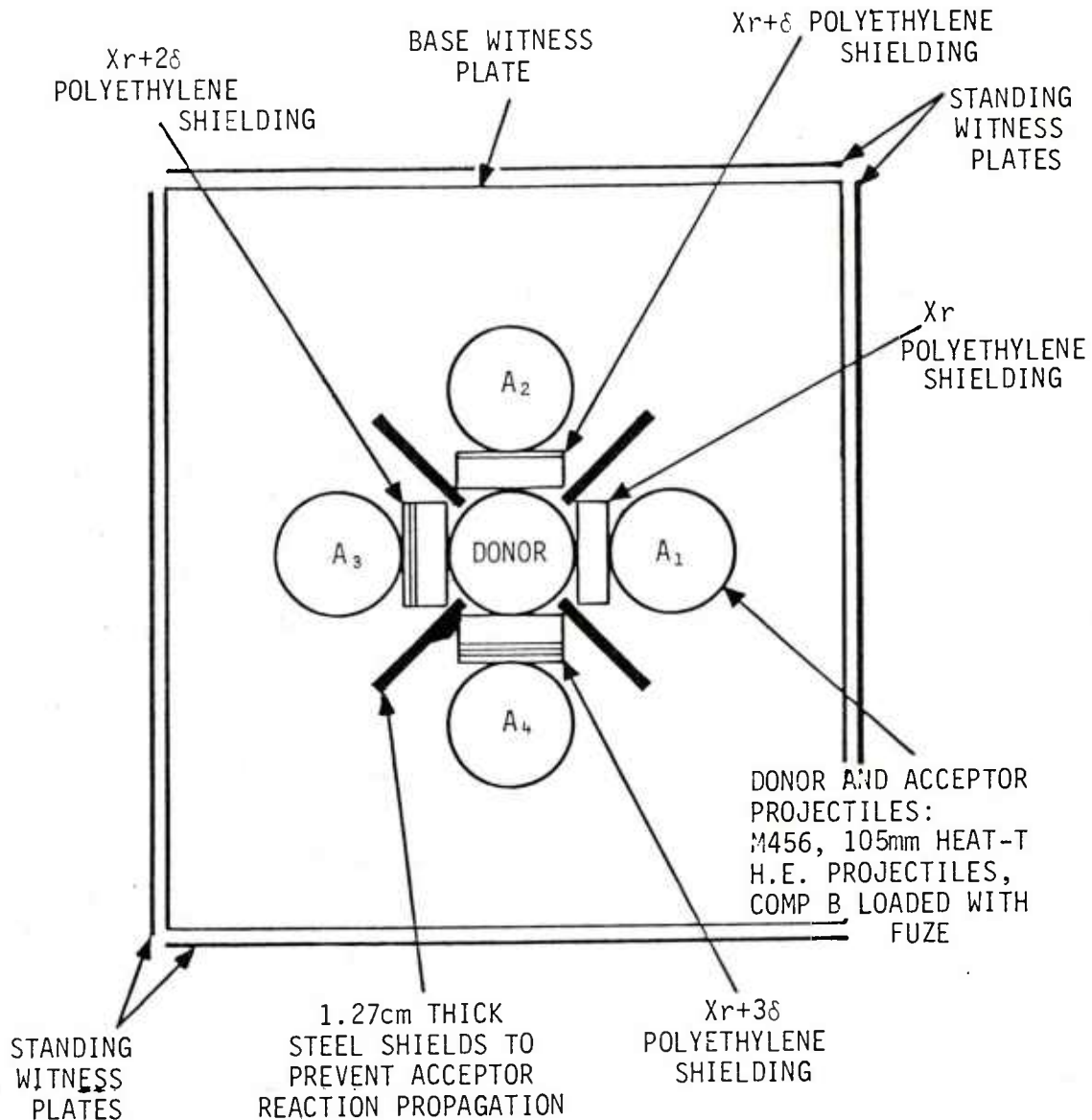

$X_r = 9.53\text{mm}$        $\delta = 3.18\text{mm}$   
 $X_{r+\delta} = 12.70\text{mm}$        $X_{r+2\delta} = 15.88\text{mm}$        $X_{r+3\delta} = 19.05\text{mm}$   
 (Witness plates are 2.67mm thick mild steel)

RESULTS: Acceptor round  $A_1$  detonated. Fragments from the other acceptor rounds were recovered. The standing witness panel adjacent to  $A_1$  had many small perforations. The witness panel adjacent to  $A_2$  had several large perforations. The witness panels adjacent to  $A_3$  and  $A_4$  had several large perforations and some unburned H.E. deposited on them. The base witness plate had tailfin imprints where  $A_1$  and the donor round had detonated.

TEST NO: KAA0331B1  
DATE: 31 MARCH 1981

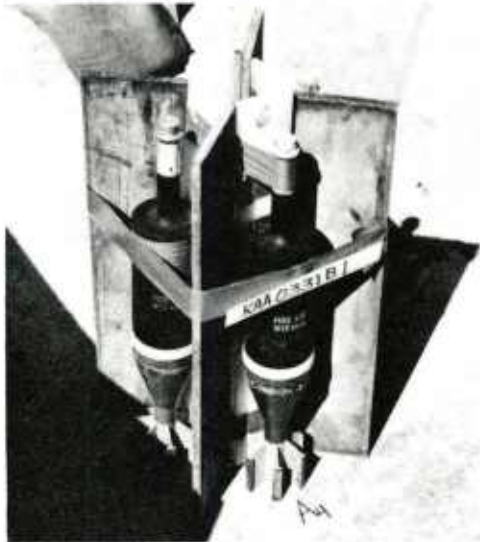

DONOR AND ACCEPTOR  
PROJECTILES BEFORE TEST

FRAGMENTS OF ACCEPTOR  
PROJECTILES RECOVERED  
AFTER TEST



TEST NO: KAA0331B1  
DATE: 31 MARCH 1981

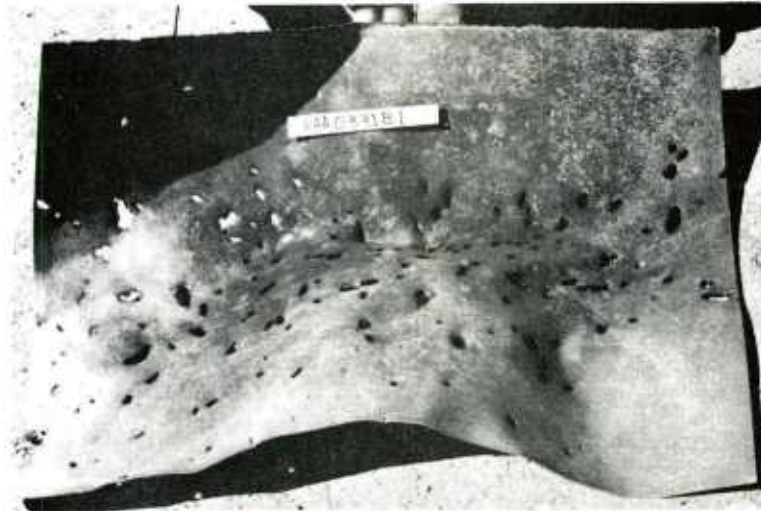

WITNESS PANEL WHICH STOOD  
ADJACENT TO ACCEPTOR PROJECTILE, A<sub>1</sub>

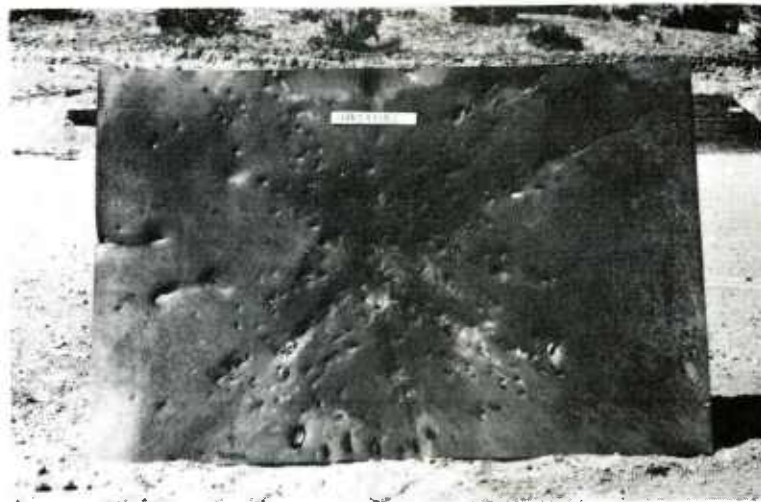

BASE WITNESS PLATE AFTER TEST

# COMPARTMENTALIZATION SHIELDING TEST

TEST: KAA0331C1

DATE: 31 MARCH 1981 TIME: 1110 MST

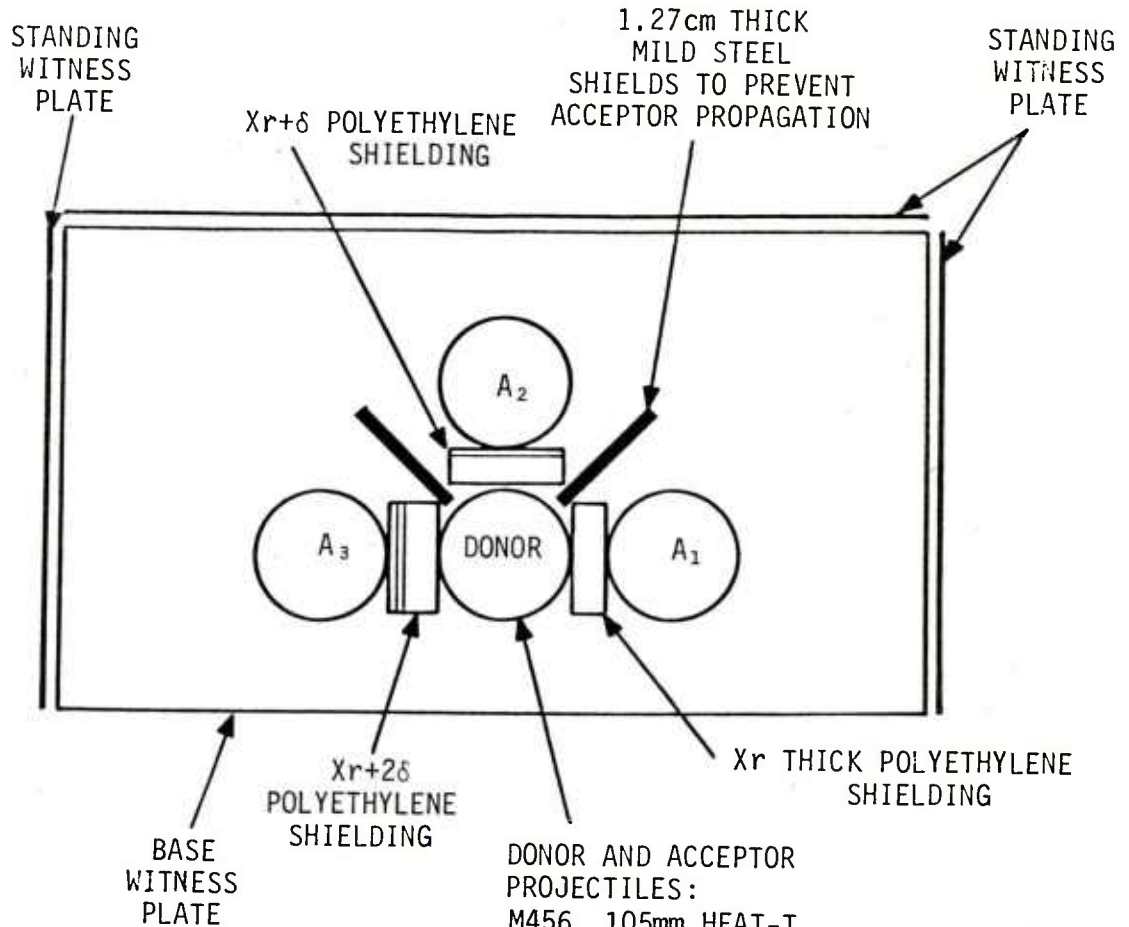

$X_r = 12.70\text{mm}$      $\delta = 3.18\text{mm}$   
 $X_r + \delta = 15.88\text{mm}$      $X_r + 2\delta = 19.05\text{mm}$

DONOR AND ACCEPTOR  
 PROJECTILES:  
 M456, 105mm HEAT-T  
 H.E. PROJECTILES,  
 COMP B LOADED WITH FUZE

(Witness plates are 2.67mm thick mild steel)

RESULTS: None of the acceptor rounds detonated. The witness panel adjacent to  $A_1$  had no perforations, nor was H.E. deposited on it. The witness panel adjacent to  $A_2$  had two large perforations, and a small amount of unburned H.E. was deposited on it. The witness panel adjacent to  $A_3$  had several large perforations, and some burned and unburned H.E. was deposited on it. A tailfin imprint was left in the base witness plate by the detonation of the donor round.

TEST NO: KAA0331C1  
DATE: 31 MARCH 1981



DONOR AND ACCEPTOR  
PROJECTILES BEFORE TEST

FRAGMENTS OF ACCEPTOR  
PROJECTILES RECOVERED  
AFTER TEST



# COMPARTMENTALIZATION SHIELDING TEST

TEST: KAA0331D1

DATE: 31 MARCH 1981 TIME: 110 MST

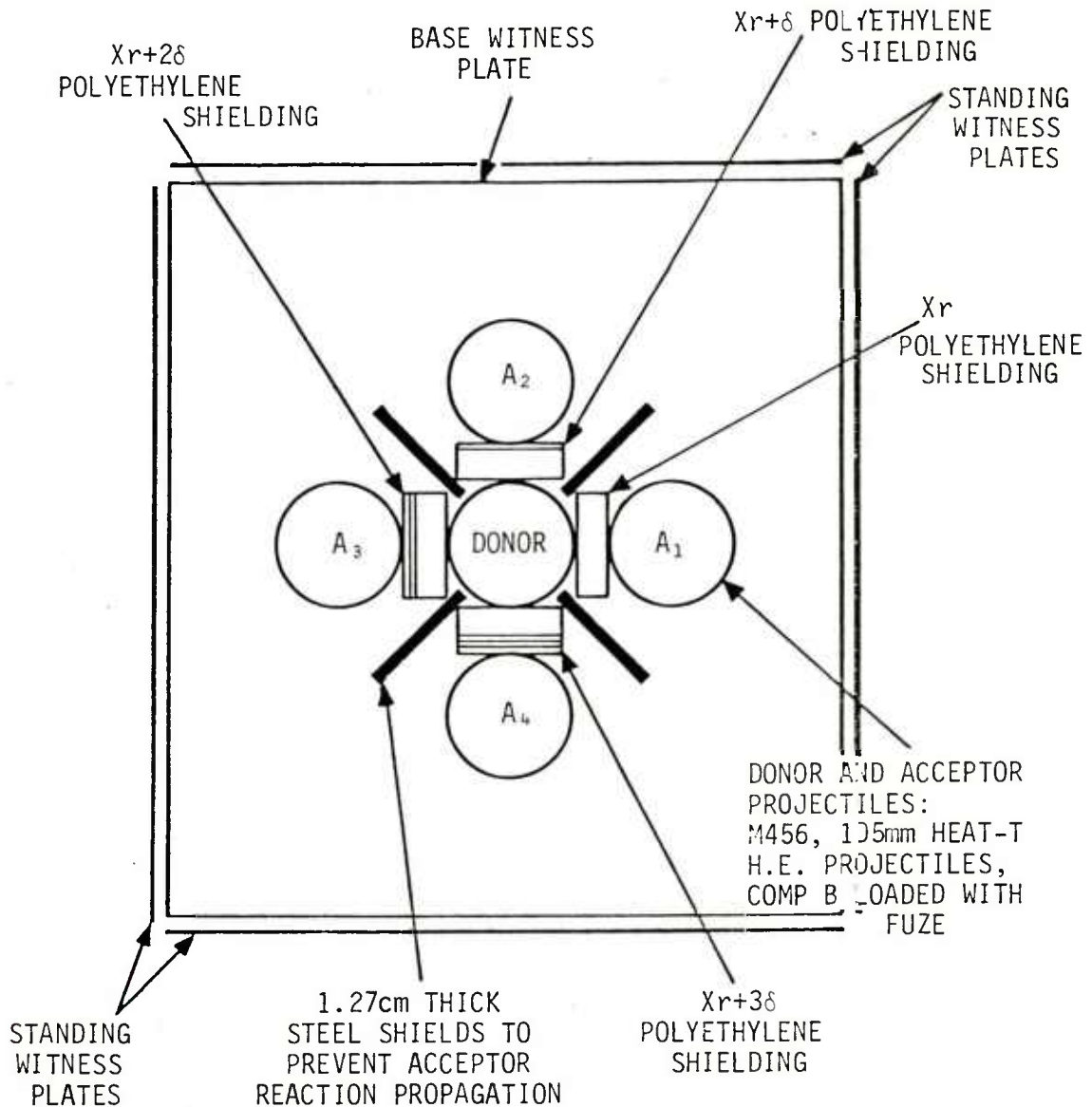

$X_r = 9.53\text{mm}$

$\delta = 3.18\text{mm}$

$X_{r+\delta} = 12.70\text{mm}$

$X_{r+2\delta} = 15.88\text{mm}$

$X_{r+3\delta} = 19.05\text{mm}$

(Witness plates are 2.67mm thick mild steel)

RESULTS: Acceptor round  $A_1$  detonated. The witness panel adjacent to  $A_1$  has many small perforations; no H.E. was deposited on it. The witness panels adjacent to  $A_2$  and  $A_3$  had several large perforations, and some burned and unburned explosives were deposited on them. The witness panel adjacent to  $A_4$  had several large perforations, but no H.E. was deposited on it. There were tailfin imprints left by the detonation of  $A_1$  and the donor round.

TEST NO: KAA0331D1  
DATE: 31 MARCH 1981



DONOR AND ACCEPTOR  
PROJECTILES BEFORE TEST

FRAGMENTS OF ACCEPTOR  
PROJECTILES RECOVERED  
AFTER TEST



TEST NO: KAA0331D1  
DATE: 31 MARCH 1981



STANDING WITNESS PANEL  
WHICH STOOD ADJACENT  
TO ACCEPTOR A<sub>1</sub>

BASE WITNESS  
PLATE AFTER  
TEST



# COMPARTMENTALIZATION SHIELDING TEST

TEST: KAA0331E1

DATE: 31 MARCH 1981 TIME: 1400 MST

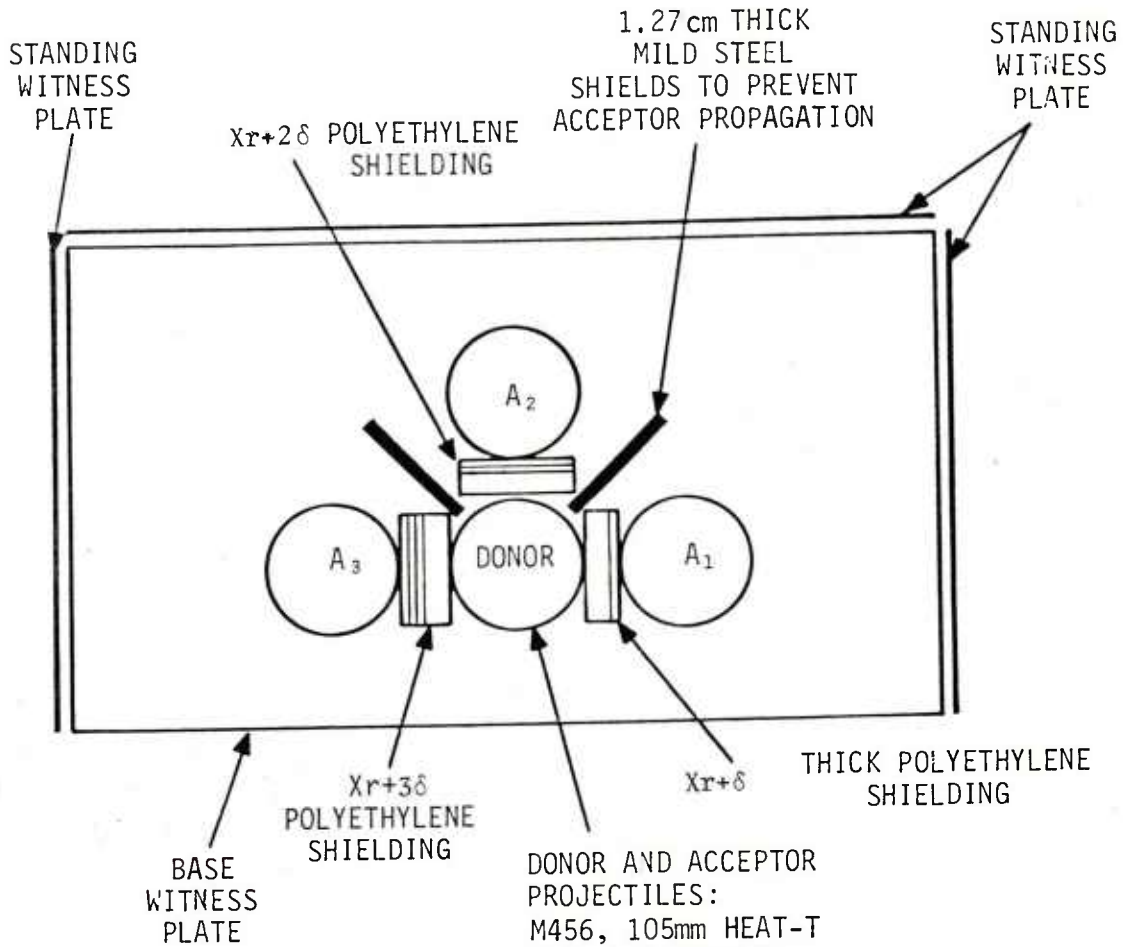

$X_r = 9.53\text{mm}$        $\delta = 3.18\text{mm}$   
 $X_{r+2\delta} = 12.70\text{mm}$      $X_{r+3\delta} = 15.88\text{mm}$

DONOR AND ACCEPTOR  
 PROJECTILES:  
 M456, 105mm HEAT-T  
 H.E. PROJECTILES,  
 COMP B LOADED WITH FUZE

(Witness plates are 2.67mm thick mild steel)

**RESULTS:** None of the acceptor rounds detonated. The witness panel adjacent to  $A_1$  had a large perforation; some burned and some unburned H.E. was deposited on it. The witness panel adjacent to  $A_2$  had several large perforations, and some burned H.E. was deposited on it. The witness panel adjacent to  $A_3$  was not perforated; there was burned and unburned H.E. deposited on it. The base witness plate had a tailfin imprint from the detonation of the donor round.

TEST NO: KAA0331E1  
DATE: 31 MARCH 1981



DONOR AND ACCEPTOR  
PROJECTILES BEFORE TEST

FRAGMENTS OF ACCEPTOR  
PROJECTILES RECOVERED  
AFTER TEST

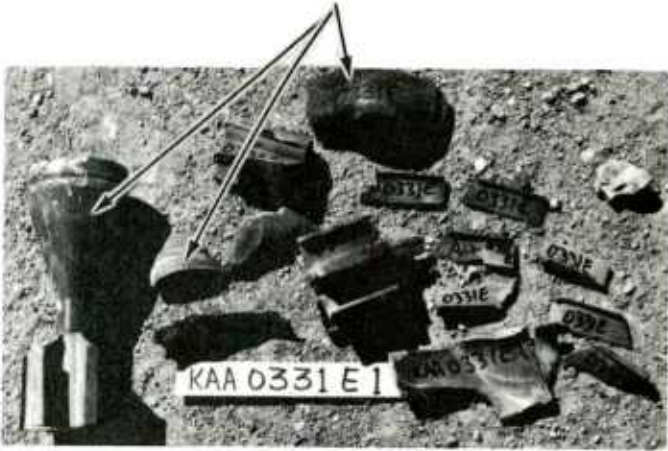

BASE WITNESS PLATE  
AFTER TEST

# COMPARTMENTALIZATION SHIELDING TEST

TEST: KAA0331F1

DATE: 31 MARCH 1981 TIME: 1450 MST

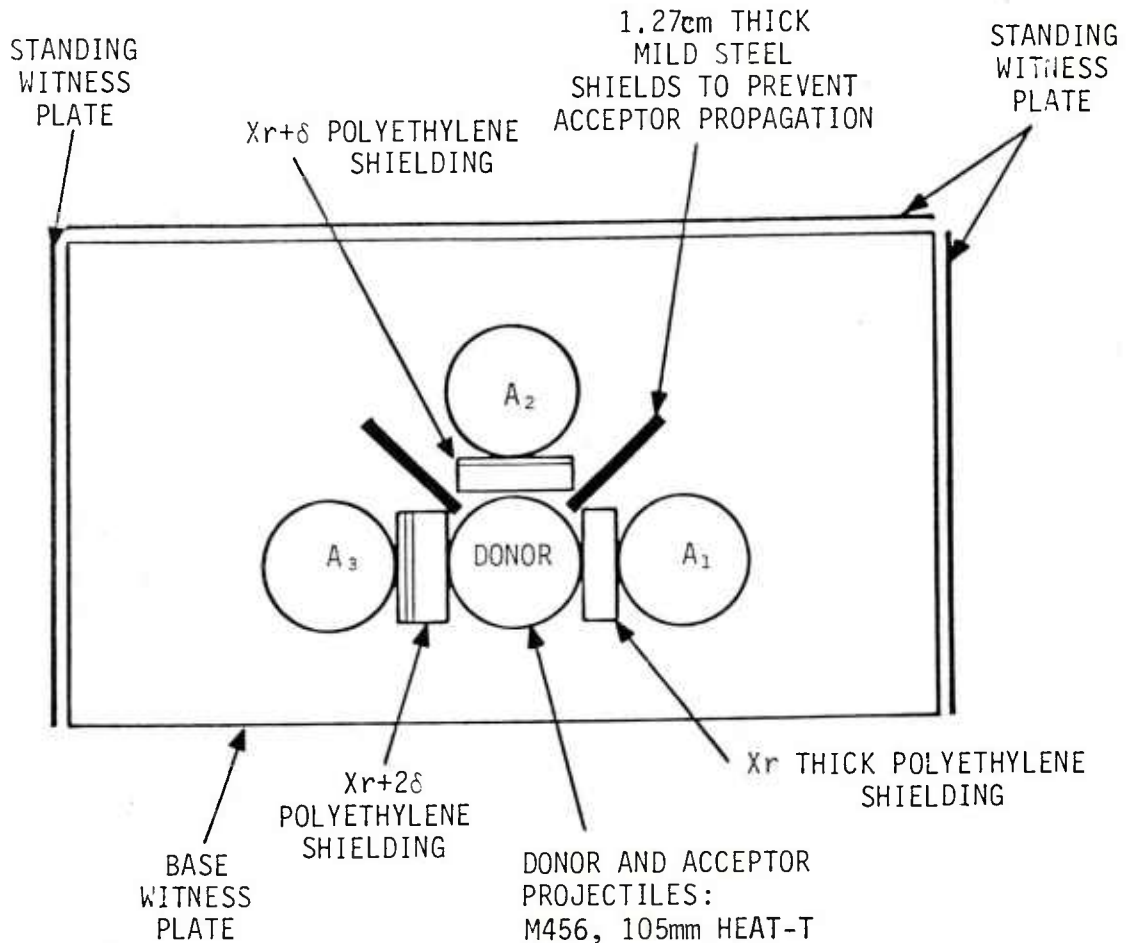

$X_r = 9.53\text{mm}$        $\delta = 3.18\text{mm}$   
 $X_r + \delta = 12.70\text{mm}$        $X_r + 2\delta = 15.88\text{mm}$

DONOR AND ACCEPTOR  
 PROJECTILES:  
 M456, 105mm HEAT-T  
 H.E. PROJECTILES,  
 COMP B LOADED WITH FUZE

(Witness plates are 2.67mm thick mild steel)

RESULTS: None of the acceptor rounds detonated. There were two large perforations in the witness panel adjacent to  $A_1$ , but there was no H.E. deposited on it. There were several large perforations in the witness panel adjacent to  $A_2$ , and there was some burned and some unburned H.E. deposited on it. A tailfin imprint in the base witness plate was left by the detonation of the donor round.

TEST NO: KAA0331F1  
DATE: 31 MARCH 1981



DONOR AND ACCEPTOR  
PROJECTILES BEFORE TEST

FRAGMENTS OF ACCEPTOR  
PROJECTILES RECOVERED  
AFTER TEST



BASE WITNESS  
PLATE AFTER  
TEST

# COMPARTMENTALIZATION SHIELDING TEST

TEST: KAA033161

DATE: 31 MARCH 1981 TIME: 1515 MST

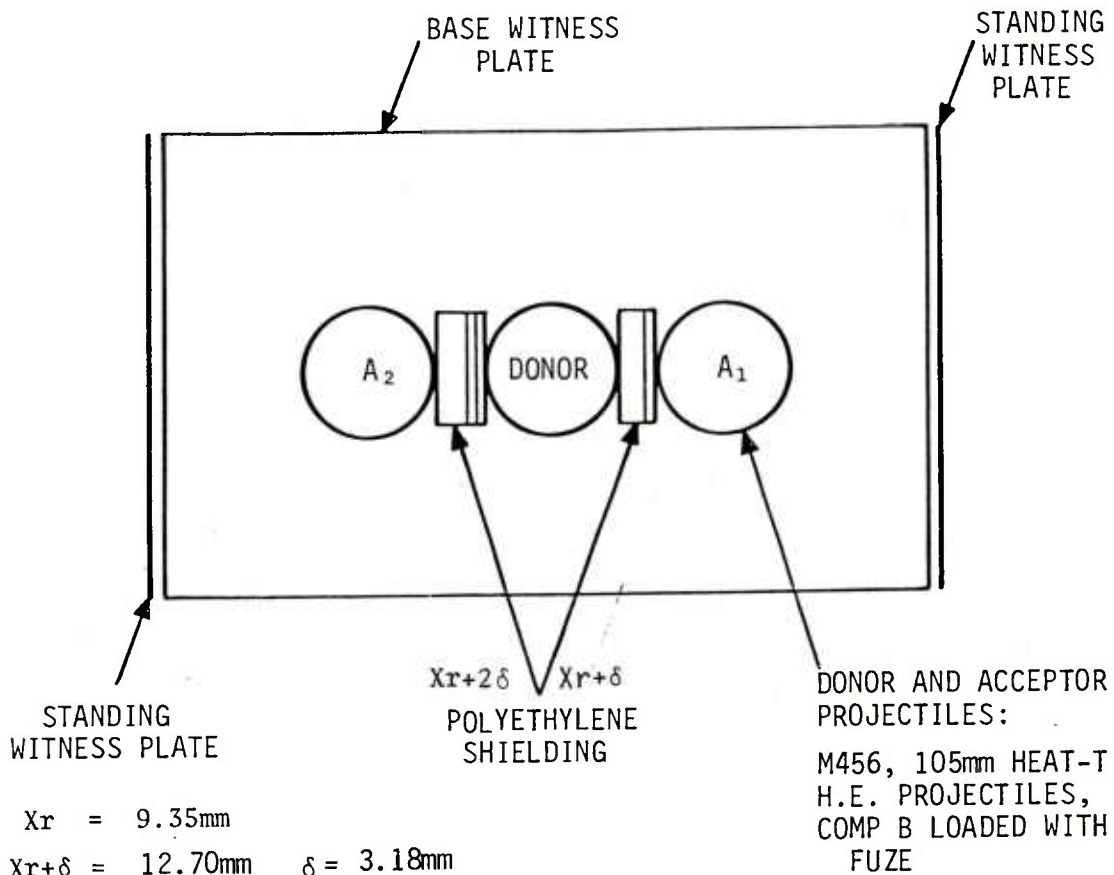

$$X_r = 9.35\text{mm}$$

$$X_{r+\delta} = 12.70\text{mm} \quad \delta = 3.18\text{mm}$$

$$X_{r+2\delta} = 15.88\text{mm}$$

(Witness plates are 2.67mm thick mild steel)

RESULTS: Neither of the acceptor rounds detonated. There were several large perforations in all the witness panels. There was burned H.E. on the witness panel adjacent to A<sub>2</sub>. There was a tailfin imprint on the base witness plate from the detonation of the donor round.

TEST NO: KAA0331G1  
DATE: 31 MARCH 1981



DONOR AND ACCEPTOR  
PROJECTILES BEFORE TEST



FRAGMENTS OF ACCEPTOR PROJECTILES  
RECOVERED AFTER TEST

# COMPARTMENTALIZATION SHIELDING TEST

TEST: KAA0331H1

DATE: 31 MARCH 1981 TIME: 1540 MST

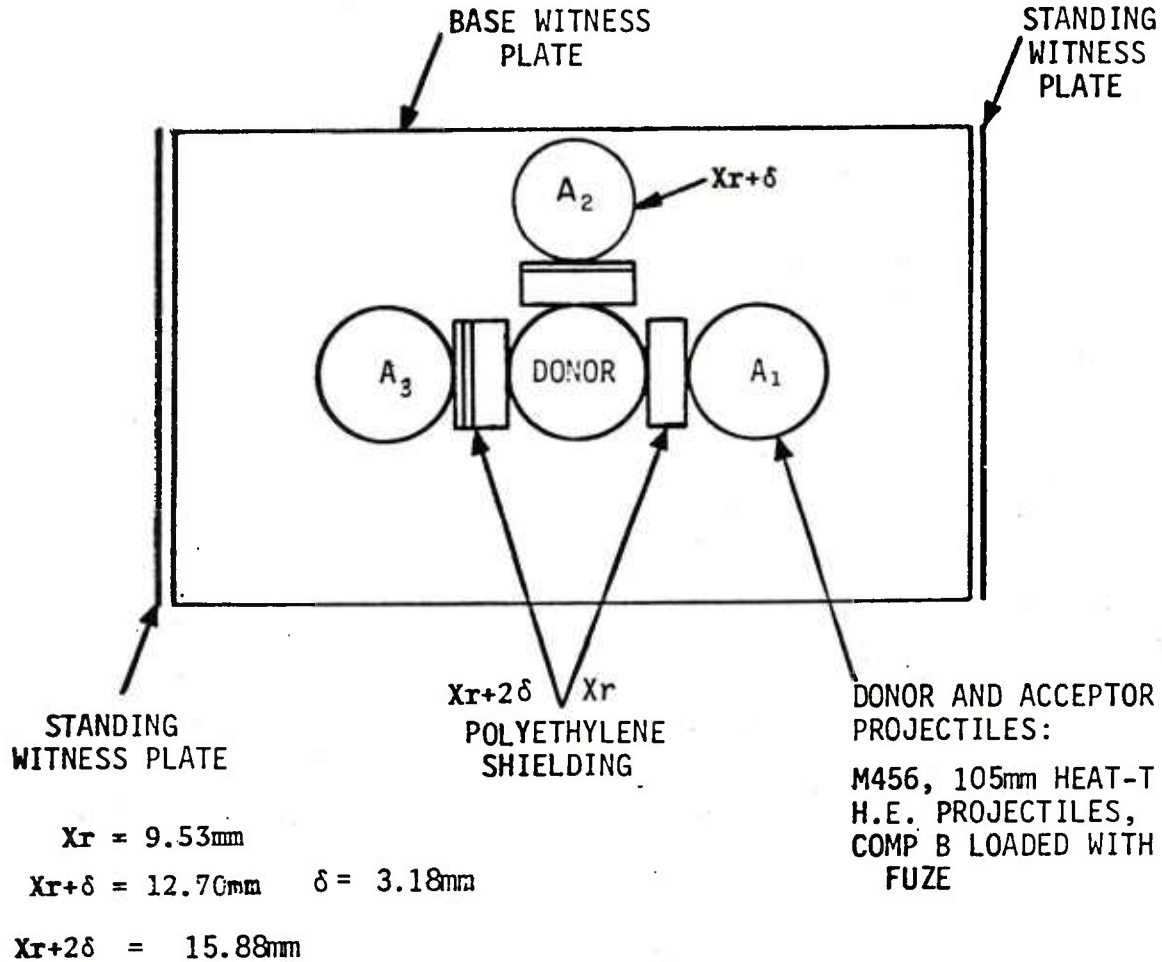

(Witness plates are 2.67mm thick mild steel)

**RESULTS:** None of the acceptor rounds detonated. The witness panels adjacent to  $A_1$  and  $A_2$  had some burned and some unburned H.E. deposited on them, but there were no perforations. The witness panel adjacent to  $A_3$  had one large perforation and a small amount of burned H.E. On the base witness plate there was a tailfin imprint from the detonation of the donor round.

TEST NO: KAA0331H1  
DATE: 31 MARCH 1981



DONOR AND ACCEPTOR  
PROJECTILES BEFORE TEST

FRAGMENTS OF ACCEPTOR  
PROJECTILES RECOVERED  
AFTER TEST



BASE WITNESS  
PLATE AFTER  
TEST

# COMPARTMENTALIZATION SHIELDING TEST

TEST: KAA033111

DATE: 31 MARCH 1981 TIME: 1600 MST

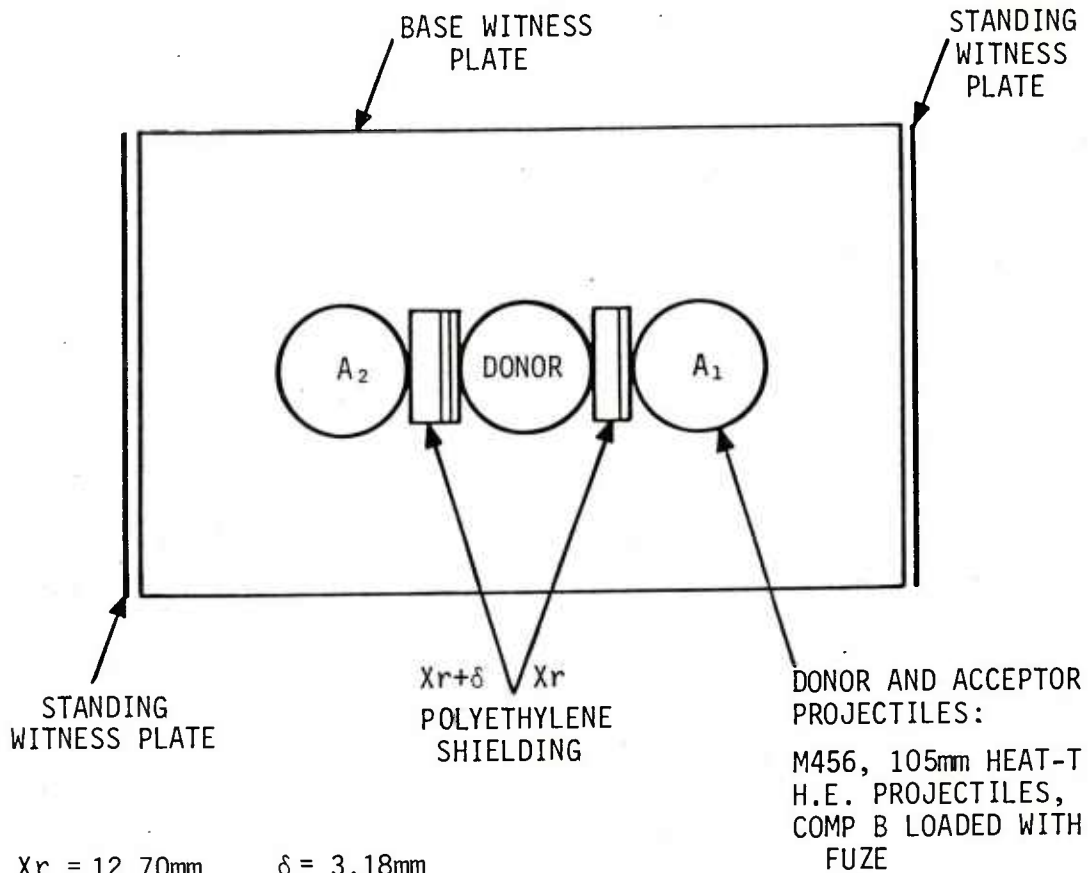

$X_r = 12.70\text{mm}$       $\delta = 3.18\text{mm}$

$X_{r+\delta} = 15.88\text{mm}$

(Witness plates are 2.67mm thick mild steel)

RESULTS: Neither of the acceptor rounds detonated. The witness panel adjacent to A<sub>1</sub> had no perforations and a small amount of unburned explosive deposited on it. The witness panel adjacent to A<sub>2</sub> had two large perforations, and some burned explosive was deposited on it. There was a tailfin imprint on the base witness plate left by the detonation of the donor round only.

TEST NO: KAA033111  
DATE: 31 MARCH 1981



DONOR AND ACCEPTOR  
PROJECTILES BEFORE TEST



FRAGMENTS OF ACCEPTOR  
PROJECTILES RECOVERED  
AFTER TEST



BASE WITNESS PLATE AFTER TEST

# COMPARTMENTALIZATION SHIELDING TEST

TEST: KAA0331J1

DATE: 31 MARCH 1981 TIME: 1645 MST

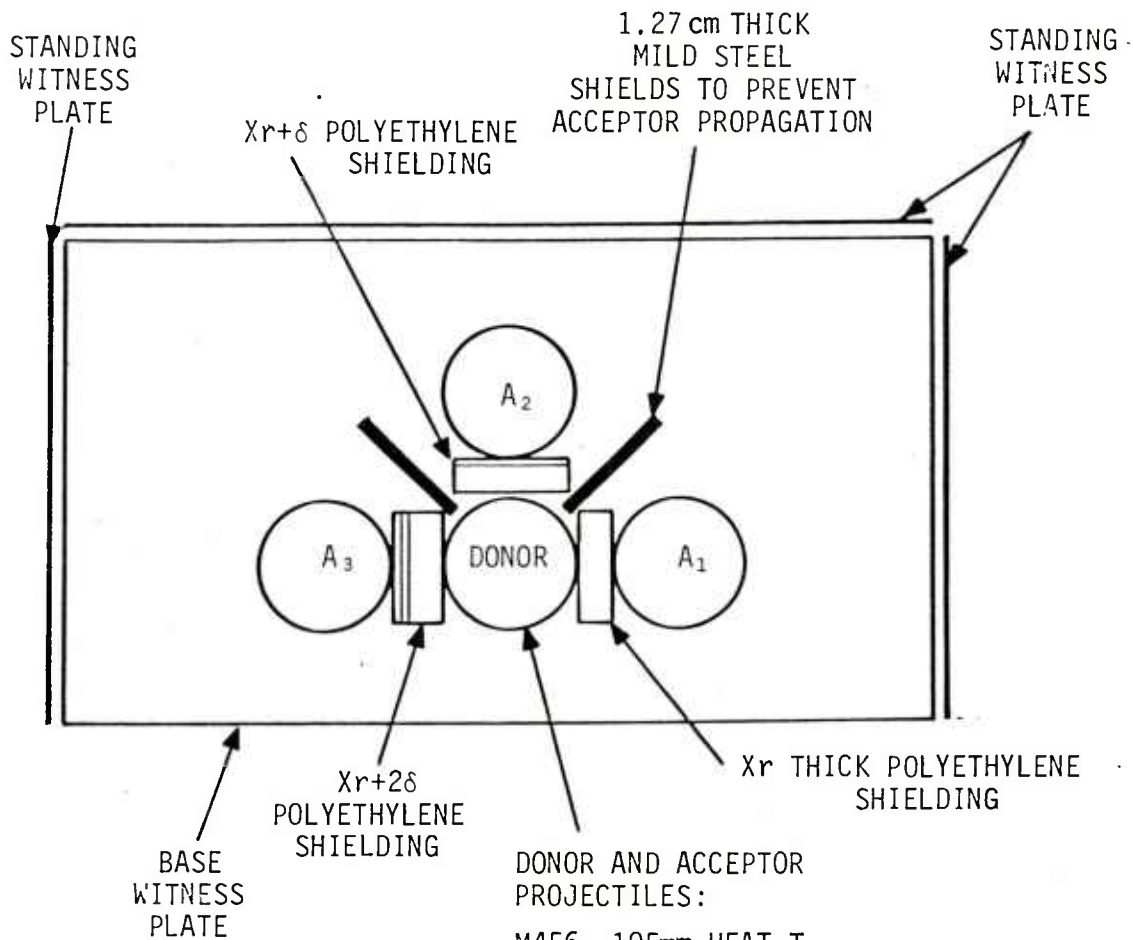

DONOR AND ACCEPTOR PROJECTILES:

M456, 105mm HEAT-T  
H.E. PROJECTILES,  
COMP B LOADED WITH  
FUZE

$X_r = 9.53\text{mm}$   $\delta = 3.18\text{mm}$

$X_{r+\delta} = 12.70\text{mm}$

$X_{r+2\delta} = 15.88\text{mm}$

(Witness plates are 2.67mm thick mild steel)

RESULTS: Acceptor  $A_1$  detonated. The witness panel adjacent to  $A_1$  had many small perforations; no explosive was deposited on it. The witness panel adjacent to  $A_2$  had one large perforation and some burned explosive was deposited on it. The witness panel adjacent to  $A_3$  had several large perforations, and no explosive was deposited on it. There were tailfin imprints left by the detonation of the donor and acceptor  $A_1$ .

TEST NO: KAA0331J1  
DATE: 31 MARCH 1981



DONOR AND ACCEPTOR  
PROJECTILES BEFORE TEST

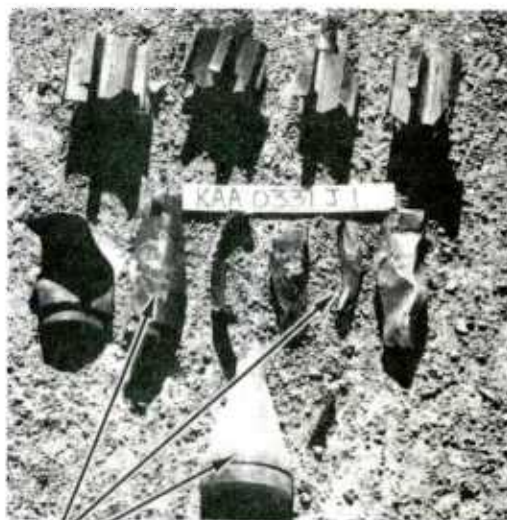

FRAGMENTS FROM ACCEPTOR  
PROJECTILES RECOVERED AFTER TEST

TEST NO: KAA0331J1  
DATE: 31 MARCH 1981



WITNESS PANEL WHICH STOOD ADJACENT  
TO ACCEPTOR PROJECTILE, A<sub>1</sub>

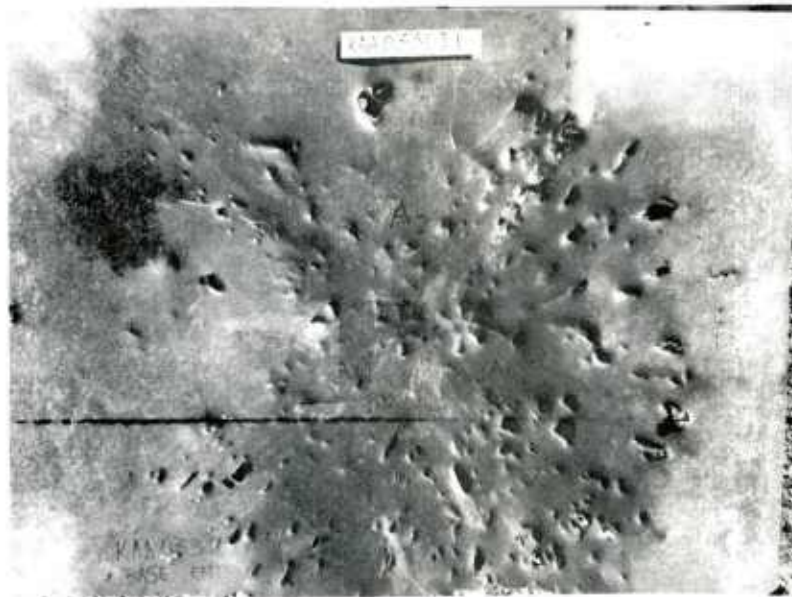

BASE WITNESS PLATE AFTER TEST

DISTRIBUTION LIST

<u>No. of Copies</u>	<u>Organization</u>	<u>No. of Copies</u>	<u>Organization</u>
12	Commander Defense Technical Info Center ATTN: DDC-DDA Cameron Station Alexandria, VA 22314	6	Commander US Army Armament Research and Development Command ATTN: DRDAR-TSS (2 cys) DRDAR-LCE, Dr. R.F. Walker DRDAR-LCE, Dr. N. Slagg DRDAR-LCM, Mr. R. Rindner DRDAR-LCM, Mr. W. Stirrat Dover, NJ 07801
2	Chairman DOD Explosives Safety Board ATTN: Dr. T. Zaker Mr. P. Price Hoffman Bldg. I, Rm 856-C 2461 Eisenhower Avenue Alexandria, VA 22331	4	Commander US Army Armament Materiel Readiness Command ATTN: DRSAR-LEP-L, Tech Lib DRSAR-LC, Mr. L. Ambrosini Mr. W. Fortune Mr. R. Freeman Rock Island, IL 61299
1	HQDA (DAMA, E. Lippi) Washington, DC 20310		
1	HQDA (DAPE-HRS, J. Coakley) Washington, DC 20310		
1	Commander Ballistic Missile Defense Advanced Technology Center ATTN: Dr. David C. Sayles P. O. Box 1500 Huntsville, AL 35808	1	Director US Army ARRADCOM Benet Weapons Laboratory ATTN: DRDAR-LCB-TL Watervliet, NY 12189
1	Commander in Chief US Army Europe and Seventh Army ATTN: AEAGA-BE/Mr. P.Moran, Jr. APO, New York 09403	1	Commander US Army Aviation Research and Development Command ATTN: DRDAV-E 4300 Goodfellow Boulevard St. Louis, MO 63120
1	Commander US Army Materiel Development and Readiness Command ATTN: DRCDMD-ST 5001 Eisenhower Avenue Alexandria, VA 22333	1	Director US Army Air Mobility Research and Development Laboratory Ames Research Center Moffett Field, CA 94035
1	Commander US Army Materiel Development and Readiness Command ATTN: DRCDE-DW, Mr. S.R. Matos 5001 Eisenhower Avenue Alexandria, VA 22333	1	Commander US Army Communications Rsch and Development Command ATTN: DRDCO-PPA-SA Fort Monmouth, NJ 07703

DISTRIBUTION LIST

<u>No. of Copies</u>	<u>Organization</u>	<u>No. of Copies</u>	<u>Organization</u>
1	Commander US Army Electronics Research and Development Command Technical Support Activity ATTN: DELSD-L Fort Monmouth, NJ 07703	1	Director US Army TRADOC Systems Analysis Activity ATTN: ATAA-SL, Tech Lib White Sands Missile Range NM 88002
1	Commander US Army Missile Command ATTN: DRSMI-R Redstone Arsenal, AL 35809	1	Commander Office of Naval Research ATTN: Dr. J. Enig, Code 200B Arlington, VA 22217
1	Commander US Army Missile Command ATTN: DRSMI-YDL Redstone Arsenal, AL 35809	1	Commander Naval Sea Systems Command ATTN: Mr. R. Beauregard, SEA 64E Washington, DC 20362
1	Commander US Army Missile Command ATTN: DRSMI-RK, Dr. R.G.Rhoades Redstone Arsenal, AL 35809	2	Commander David W. Taylor Naval Ship Research & Development Center ATTN: Dr. F. Fisch Dr. S. L. Wang 6415 Bradley Boulevard Bethesda, MD 20084
1	Commander US Army Tank Automotive Rsch and Development Command ATTN: DRDTA-UL Warren, MI 48090	1	Commander Naval Surface Weapons Center ATTN: Code G13 Dahlgren, VA 22448
1	Commander Tooele Army Depot ATTN: F. Crist Tooele, UT 84074	9	Commander Naval Surface Weapons Center ATTN: Mr. L. Roslund, R122 Mr. M. Stosz, R121 Code X211, Lib E. Zimet, R13 R.R. Bernecker, R13 J.W. Forbes, R13 S.J. Jacobs, R10 K. Kim, R13 M. Swisdak Silver Spring, MD 20910
1	Program Manager MI Abrams Tank System ATTN: DRCPM-GCM-S Warren, MI 48090		
1	Commander US Army Research Office ATTN: Chemistry Division P. O. Box 12211 Research Triangle Park NC 27709		

DISTRIBUTION LIST

<u>No. of Copies</u>	<u>Organization</u>	<u>No. of Copies</u>	<u>Organization</u>
3	Commander Naval Weapons Center ATTN: Dr. L. Smith, Code 3205 Dr. A. Amster, Code 385 Dr. R. Reed, Jr., Code 388 China Lake, CA 93555	1	Director Lawrence Livermore National Lab University of California ATTN: Dr. M. Finger Livermore, CA 94550
1	Commander Naval Explosive Ordnance Disposal Facility ATTN: Tech Lib, Code 604 Indian Head, MD 20640	1	Director Los Alamos National Lab ATTN: Dr. B. Craig, M. Division P. O. Box 1663 Los Alamos, NM 87545
1	Commander Naval Research Laboratory ATTN: Code 6100 Washington, DC 20375		<u>Aberdeen Proving Ground</u>  Dir, USAMSAA ATTN: DRXSY-D DRXSY-MP, H. Cohen
1	Commanding General Fleet Marine Force, Atlantic ATTN: G-4 (NSAP) Norfolk, VA 23511		Cdr, USATECOM ATTN: DRSTE-TO-F
1	AFRPL/MKPA (Mr. R. Geisler) Edwards AFB, CA 93523		Dir, USACSL, Bldg. E3516, EA ATTN: DRDAR-CLB-PA

USER EVALUATION OF REPORT

Please take a few minutes to answer the questions below; tear out this sheet, fold as indicated, staple or tape closed, and place in the mail. Your comments will provide us with information for improving future reports.

1. BRL Report Number \_\_\_\_\_

2. Does this report satisfy a need? (Comment on purpose, related project, or other area of interest for which report will be used.)

\_\_\_\_\_  
\_\_\_\_\_  
\_\_\_\_\_

3. How, specifically, is the report being used? (Information source, design data or procedure, management procedure, source of ideas, etc.) \_\_\_\_\_

\_\_\_\_\_  
\_\_\_\_\_

4. Has the information in this report led to any quantitative savings as far as man-hours/contract dollars saved, operating costs avoided, efficiencies achieved, etc.? If so, please elaborate.

\_\_\_\_\_  
\_\_\_\_\_

5. General Comments (Indicate what you think should be changed to make this report and future reports of this type more responsive to your needs, more usable, improve readability, etc.) \_\_\_\_\_

\_\_\_\_\_  
\_\_\_\_\_  
\_\_\_\_\_

6. If you would like to be contacted by the personnel who prepared this report to raise specific questions or discuss the topic, please fill in the following information.

Name: \_\_\_\_\_

Telephone Number: \_\_\_\_\_

Organization Address: \_\_\_\_\_

\_\_\_\_\_  
\_\_\_\_\_