

AD A107106



LEVEL 1

~~scribble~~
9

Symposium on Commercial Aviation Energy Conservation Strategies

April 2-3, 1981

DTIC
ELECTE
NOV 05 1981
S E

Papers and Presentations

Cosponsored by:
U.S. Department of Energy
Federal Aviation Administration

DTIC FILE COPY

This document has been approved
for public release and sale; its
distribution is unlimited.

81 10 29 020

1. Report No.	2. Government Accession No. AD-A107 106	3. Recipient's Catalog No.	
4. Title and Subtitle Symposium on commercial aviation energy conservation strategies April 2-3, 1981. Papers and presentations.		5. Report Date April 1981	6. Performing Organization Code
7. Author(s)		8. Performing Organization Report No.	
9. Performing Organization Name and Address Department of Energy and Federal Aviation Administration. Washington, D. C. 393715		10. Work Unit No. TRAIS	11. Contractor or Grant No.
12. Sponsoring Agency Name and Address Department of Energy and Federal Aviation Administration. Washington, D. C.		13. Type of Report and Period Covered	
14. Sponsoring Agency Code		15. Supplementary Notes	
16. Abstract <p>The U. S. Department of Energy (DOE) and the Federal Aviation Administration (FAA) sponsored a Symposium on Commercial Aviation Energy Conservation Strategies on April 2-3, 1981, in Washington, D. C., at the Washington Hilton Hotel.</p> <p>The Symposium provided a forum in which representatives from DOE, FAA, National Aeronautics and Space Administration (NASA) and the aviation industry exchanged information and ideas regarding current and future efforts to conserve fuel and to promote energy conservation within the commercial aviation sector. General topics discussed included Federal and industry energy conservation programs such as flight operations, air traffic control, engineering and maintenance, and corporate management strategies. The Symposium was highlighted by a panel discussion entitled "Energy Conservation: Where Do We Go From Here?"</p> <p>This report contains the papers and presentations from the Symposium.</p>			
17. Key Words		18. Distribution Statement Document is available to the U. S. public through the National Technical Information Service, Springfield, Virginia 22161	
19. Security Classification of this report Unclassified	20. Security Classification of this page Unclassified	21. Number of Pages 382	22. Price



Accession For	
NTIS GRA&I	<input checked="" type="checkbox"/>
DTIC TAB	<input type="checkbox"/>
Unannounced	<input type="checkbox"/>
Justification	
By _____	
Distribution/	
Availability Codes	
Avail and/or	
Dist	Special
A	

⑥ **Symposium on
Commercial Aviation
Energy Conservation
Strategies.**

April 2-3, 1981.

Papers and Presentations.

⑫ 374

11/1 81

Cosponsored by:
U.S. Department of Energy
Federal Aviation Administration

393745

FOREWORD

The U.S. Department of Energy (DOE) and the Federal Aviation Administration (FAA) sponsored a Symposium on Commercial Aviation Energy Conservation Strategies on April 2-3, 1981, in Washington, D.C., at the Washington Hilton Hotel.

The Symposium provided a forum in which representatives from DOE, FAA, National Aeronautics and Space Administration (NASA) and the aviation industry exchanged information and ideas regarding current and future efforts to conserve fuel and to promote energy conservation within the commercial aviation sector. General topics discussed included Federal and industry energy conservation programs such as flight operations, air traffic control, engineering and maintenance, and corporate management strategies. The Symposium was highlighted by a panel discussion entitled "Energy Conservation: Where Do We Go From Here?"

This report contains the papers and presentations from the Symposium. The United States Government assumes no liability for its contents or use thereof. The views and opinions of authors expressed herein do not necessarily state or reflect those of DOE or FAA. Reference herein to any specific commercial product, process, or service by trade name, mark, manufacturer, or otherwise, do not necessarily constitute or imply its endorsement, recommendation, or favoring by the United States Government or any agency thereof.

ACKNOWLEDGEMENTS

Arrangements for the Symposium were coordinated by Mr. E.W. Gregory, II from DOE, Office of Transportation Programs, and Ms. Cindy Zook from FAA, Office of Environment and Energy. Special thanks also go to Mr. Robert Bowles, formerly with DOE, and now with FAA, who initiated planning for the Symposium.

An important contribution to this effort was provided by the staff at OAO Corporation, especially Ms. Jane Carley and Mr. Robert Dentz.

TABLE OF CONTENTS

	<u>PAGE</u>
PART I: DOE AVIATION ENERGY CONSERVATION PROGRAMS	
Potential Fuel Savings Through Improved Airframe Maintenance	3
R. R. Covey, B. M. Pershing, and R. S. Knight	
Development of a Procedure for Calculating the Effects of Airfoil Erosion on Aircraft Engine Compressor Performance	31
O. J. McMillan	
Aircraft Towing Feasibility Study	45
Henry S. L. Fan and Dan G. Haney	
The Analysis of Integrated Fuel Efficient, Low Noise Procedures in LAX Terminal Area Operations	57
John B. McKinley and Robert L. Bowles	
PART II: DOT/FAA AVIATION ENERGY CONSERVATION POLICY	
An Overview	81
Charles J. Hoch	
LUNCHEON REMARKS	95
Eldred N. Cart, Jr.	
PART III: FLIGHT OPERATIONS AND AIR TRAFFIC CONTROL	
Airline Flight Planning - The Weather Connection	105
Robert Steinberg	
Flight Preparation and Planning	127
Brooks Schooley	
Fuel Conservation Techniques in Jet Transport Aircraft Operations	137
H. H. Craven, Jr.	
Air Traffic Control: Its Effect on Fuel Conservation	147
Edwin H. Price	
Fuel Conservation During Descent	155
Captain N. F. Anderson	
The Delay Management Process	163
Roger E. Brubaker	

	<u>PAGE</u>
PART IV: ENGINEERING AND MAINTENANCE CONSERVATION STRATEGIES	
Computerized Engine and Airplane Performance Monitoring Programs	171
M. B. Schwartz and A. E. Domke	
Slideslip Indication System	209
Dieter Horst	
Turbine Engine Fuel Conservation by Fan and Compressor Profile Control	231
William B. Roberts and William Rogers	
PART V: CORPORATE MANAGEMENT CONSERVATION TOOLS	
A Practical Economic Criterion for Fuel Conservation	259
D. Roger Ferguson	
Pilot/Aircraft Fuel Performance Evaluation	281
Gordon A. McKinzie	
LUNCHEON REMARKS.....	307
The Honorable Dan Glickman	
PART VI: WHERE DO WE GO FROM HERE?	
Panel Presentations	
Richard T. Alpaugh	323
Charles J. Hoch	331
Roger Winblade	335
Gordon A. McKinzie	341
J. Dawson Ransome	345
Richard L. Altman	349
Joseph C. Snodgrass	363
Thomas E. Sheppard	365
Question and Answer Session	369
CLOSING REMARKS	375
John E. Wesler	





PART I

DOE AVIATION ENERGY CONSERVATION PROGRAMS

POTENTIAL FUEL SAVINGS THROUGH IMPROVED AIRFRAME MAINTENANCE

R. R. Covey and B. M. Pershing
The Aerospace Corporation
El Segundo, California

and

R. S. Knight
Continental Airlines
Los Angeles, California

ABSTRACT

This paper presents preliminary results obtained from a program comprising an analytical projection and the flight verification of potential fuel savings obtainable through improved airframe maintenance of commercial jet transport aircraft. Realization of the savings depends on the removal of drag inducing airframe discrepancies incurred in normal revenue service. In the two-task program, one task developed and utilized methods to project analytically the potential improved airframe maintenance-related fuel savings of each aircraft in a fleet of 15 DC-10's. These projections were formulated using a discrepancy data base developed from detailed physical inspections of each aircraft. The second task addressed the verification of fuel savings through the collection and analysis of pre- and post-maintenance flight performance data obtained on two of the DC-10's while in normal revenue service. Based on multivariable linear regression analyses of the flight data, one aircraft showed a decrease in fuel consumption of 0.4 percent at a confidence level in excess of 98 percent, compared to an analytical projection of 0.6 percent. Flight verification results from the second aircraft were inconclusive due to collection of a significant block of data under unstable flight conditions. Cost effectivity studies of improved airframe maintenance are currently in progress and will be published at a later date.

POTENTIAL FUEL SAVINGS THROUGH IMPROVED AIRFRAME MAINTENANCE

INTRODUCTION

During the past few years, the commercial air transportation industry has identified a number of operational energy conservation strategies intended to save jet fuel. One of these strategies is the improvement of airframe maintenance solely for purposes of fuel conservation. The opportunity for realization of fuel savings through improved airframe maintenance arises because commercial transport aircraft in normal revenue service are subject to small changes in airframe configuration. These changes occur due to a number of causes including normal wear, component deterioration, hail damage, and minor ground handling incidents. Incurrence of so-called airframe discrepancies due to these and other causes results in small increases in aerodynamic drag with an attendant increase in fuel consumption. It is the reduction of these incremental drag contributions through improved airframe maintenance that provides the potential for recovery of incremental fuel expenditures. The cost effectivity of a specific maintenance action depends on the magnitude of the fuel savings recovered, the price of fuel, the life expectancy of the repair, the cost of the maintenance action, and investment rate-of-return criteria. The last item is of consequence because increased costs associated with improved airframe maintenance could be foregone and instead applied to alternative investments.

Earlier studies such as those of References 1 through 4 have provided a number of analytically based estimates of potential fuel savings available through improved airframe maintenance. However, management staffs of many airlines have not been convinced that the projected fuel savings are cost effective, or indeed even exist. As a result, investigations reported in Reference 5 indicated the need for development of algorithms that could be used to parametrically assess the cost effectivity of improved airframe maintenance as costs and rate-of-return criteria vary widely. Furthermore, a need for verification of projected

fuel savings during normal revenue flight service was also noted in Reference 5 studies. Verification was identified as a need in response to a requirement voiced by management of various airlines to show that analytically projected fuel savings do indeed exist in the wide scatter band that typically characterizes aircraft fuel consumption performance data. Revenue flight verification of these small but important fuel savings is widely recognized as a difficult task that, at best, can only be approached by using sophisticated statistical techniques. However, an initial assessment of the problem indicated that a reasonable probability existed for detection of the fuel savings. As a result, the U.S. Department of Energy's (DOE)'s Systems Efficiency Branch under Mr. R. T. Alpaugh initiated the Improved Airframe Maintenance Program (IAMP).

IMPROVED AIRFRAME MAINTENANCE PROGRAM OVERVIEW

The IAMP is being conducted for the DOE by The Aerospace Corporation in conjunction with Continental Airlines (CAL), which provides the airframe discrepancy and flight data required to perform IAMP analyses. It is a two-phase program which develops analytical methods for assessing airframe maintenance-related fuel savings in Task I, and seeks to verify these savings in normal revenue service in Task II.

On a national level, IAMP objectives are to provide methods for U.S. air carriers to conserve strategically valuable national petroleum supplies and reduce U.S. balance of payments deficits. At the level of the individual airline, the objective and incentive of improved corporate profit is added to the national level objectives.

The CAL fleet of 15 DC-10-10 aircraft is being used for the IAMP study as a result of a unique combination of factors which met IAMP requirements. These factors include the CAL capability of providing computer-generated flight data suitable for subsequent statistical analyses and CAL management's willingness to cooperate in implementing a number of programmatic controls necessary to achieve data of a quality sufficient for IAMP requirements. Although many of the performance

figures and charts used in developing IAMP Task I material are specific to the DC-10-10, the methods and formats used are applicable to other jet transport aircraft. In addition, the verification of fuel savings shown in Task II is indicative of fuel savings that could be available to many airlines using other aircraft types.

With the exception of cost effectivity studies, IAMP tasks are essentially complete, and the results obtained to date are presented in the following sections of this paper.

TASK I: FUEL SAVINGS AND COST-BENEFIT ASSESSMENT

Under Task I of the IAMP, methods for analytically assessing fuel savings associated with improved airframe maintenance were developed and applied to the CAL fleet of DC-10-10's. As a first step, this involved development of a detailed 40-page set of forms to direct the step-by-step inspection of a DC-10-10 and provide for the recording of a data base describing the location and physical characteristics of each discrepancy logged during a detailed physical audit of the aircraft.

In parallel with the development of audit forms, procedures, charts, and figures were formulated for estimating ΔC_{D0} , an individual aircraft's incremental aerodynamic drag coefficient based upon airframe discrepancies described in the audit forms. Finally, algorithms were developed and used to project each aircraft's potential fuel savings as a function of its nominal flight profile and ΔC_{D0} . Cost-benefit studies, which also fall under Task I of the IAMP, are currently in progress and will be addressed in the IAMP final report.

Development of Incremental Drag Coefficient. In developing a general method for estimating ΔC_{D0} , airframe discrepancies were classified either as surface/seal irregularities or as misrigged control surfaces. Surface/seal irregularities include discrepancy subclasses such as non-flush skin repairs, door surface mismatches, leaky seals, skin dents, missing parts, and rough paint. Each of these subclasses contributes an

incremental drag coefficient, δC_{D0} , to the total increment in drag coefficient, ΔC_{D0} . Determination of δC_{D0} for each discrepancy subclass is dependent on individual discrepancy characteristics, which are used as data entries to the procedures, charts, and figures formulated to convert discrepancy characteristics to incremental drag assessments. Examples of individual discrepancy characteristics that are important in the surface/seal irregularity class are discrepancy type, size, orientation to the airstream, and location on the aircraft. The latter determines such critical aerodynamic factors as boundary layer thickness, flow velocity, and pressure gradient over the discrepancy.

Misrigged control surfaces are also subclassified as to type and include items such as out-of-rig ailerons, elevators, rudders, slats, flaps, and spoilers. Associated with each of these misrig subclasses is a δC_{D0} calculated by using procedures, charts, and figures paralleling those developed for the incremental drag coefficient of surface/seal irregularity subclasses. Important control surface misrig characteristics include the degree to which the misrig exceeds its normal tolerance band and the aircraft configuration. It should be noted that the overall method for estimating ΔC_{D0} developed in the IAMP is applicable to jet transport aircraft in general. However, the data of References 1 and 6 were used to develop the specific δC_{D0} contributions for the DC-10-10.

Development of Fuel Penalty Equation. Procedures for computing fuel penalty, ΔW_F , as a function of an aircraft's ΔC_{D0} and flight profile were developed based on the assumption that the effects of ΔC_{D0} on ΔW_F in the taxi, take-off, and descent phases of the flight profile are negligible and that the fuel penalty is incurred only in the climb and cruise flight phases. These assumptions are based on the fact that taxi fuel is independent of aerodynamic drag and that fuel penalties in take-off and descent are extremely small. Thus the errors in calculating ΔW_F that are introduced by these assumptions are both conservative and small. Further justification for basing ΔW_F calculations only on the climb and cruise phases of the flight profile is presented in Figure 1, which shows a

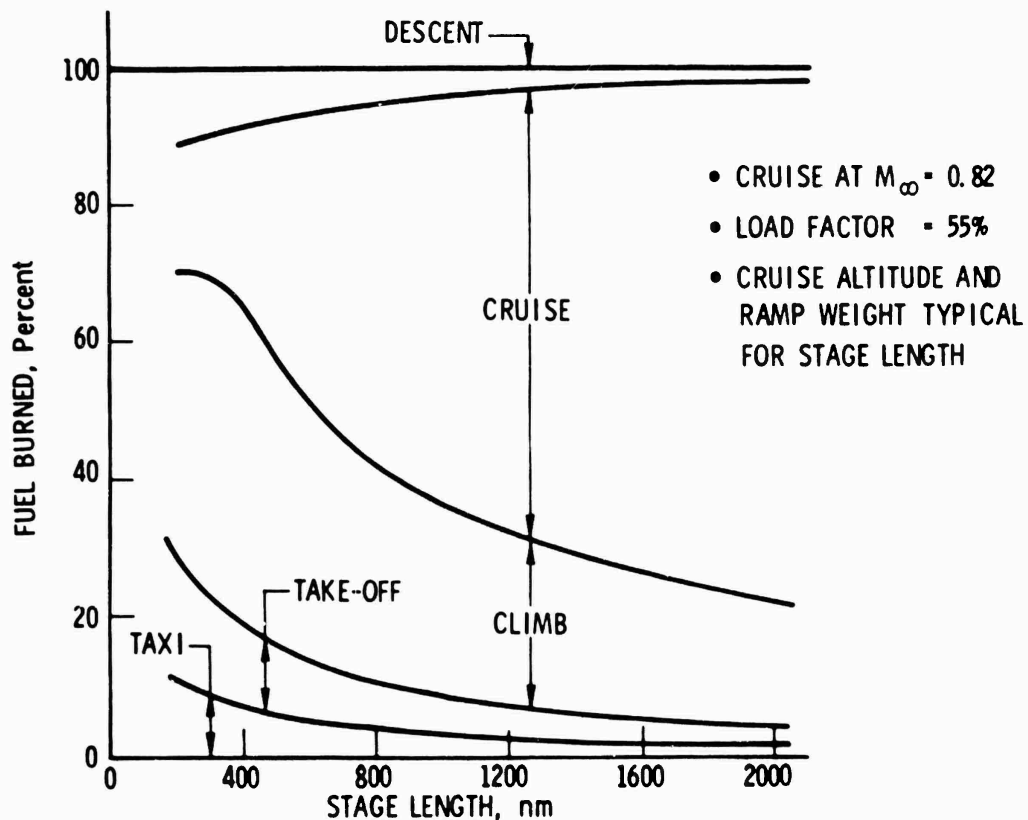

Figure 1. Breakdown of Fuel Burned for DC-10-10

breakdown of the percentage of total fuel burned by a DC-10-10, at constant load factor, for each flight phase as a function of stage length. The curves of Figure 1 are based on DC-10-10 performance data reported in Reference 7. For intermediate and long stage lengths of 1000 nm and greater, more than 90 percent of the fuel is burned in the climb and cruise flight phases. For short stage lengths of around 500 nm, the climb and cruise flight phases consume about 75 percent of the fuel. Therefore, the climb and cruise flight phase fuel-burns dominate in consideration of fuel penalties related to airframe discrepancies, and provide further justification for considering only these phases in the calculation of fuel penalty.

The expression developed for the fuel penalty, ΔW_F , is:

$$\Delta W_F = \left[\left(\frac{\Delta W_F}{\Delta C_{Do}} \right)_{CL} + \left(\frac{W_3}{C_{DCR}} \right) j_{CR} \right] \Delta C_{Do} \quad (1)$$

In Equation (1), $\left(\frac{\Delta W_F}{\Delta C_{Do}} \right)_{CL}$ is the climb fuel penalty factor shown in Figure 2, W_3 is the aircraft weight at start of cruise, C_{DCR} is the aircraft drag coefficient at average cruise weight, j_{CR} is the cruise fuel factor shown in Figure 3, and ΔC_{Do} is the aircraft total incremental drag coefficient resulting from the summation of all individual airframe discrepancy drag coefficients. The derivation of Equation (1) and a complete discussion of its application will be included in the final report.

An example of the fuel penalty for a DC-10-10 flight profile, as obtained from Equation (1), is shown in Figure 4 in the form of $\% \Delta W_F / \Delta C_{Do}$ versus stage length. At large stage lengths, $\% \Delta W_F / \Delta C_{Do} = 0.31 \times 10^4$. For

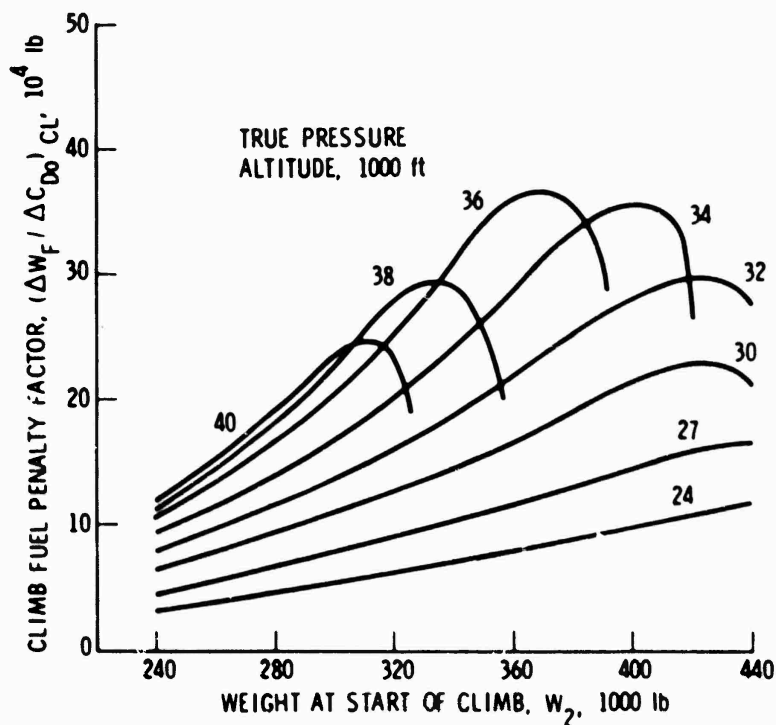

Figure 2. DC-10-10 Climb Fuel Penalty Factor

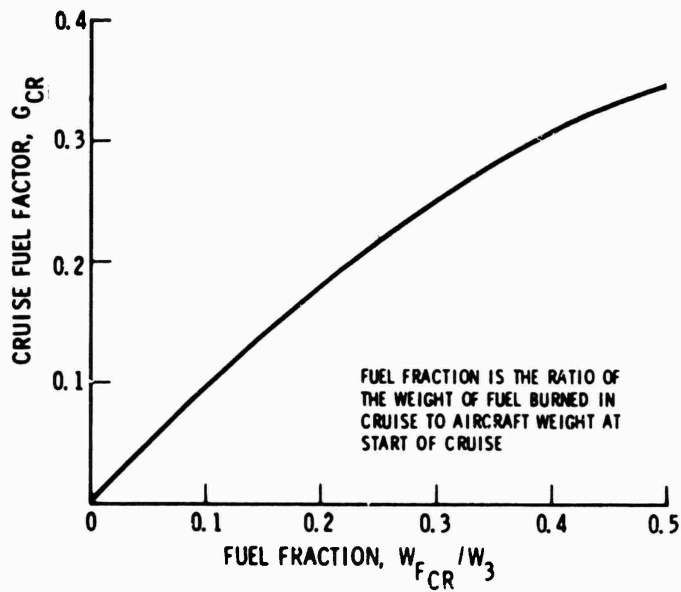

Figure 3. DC-10-10 Cruise Fuel Factor

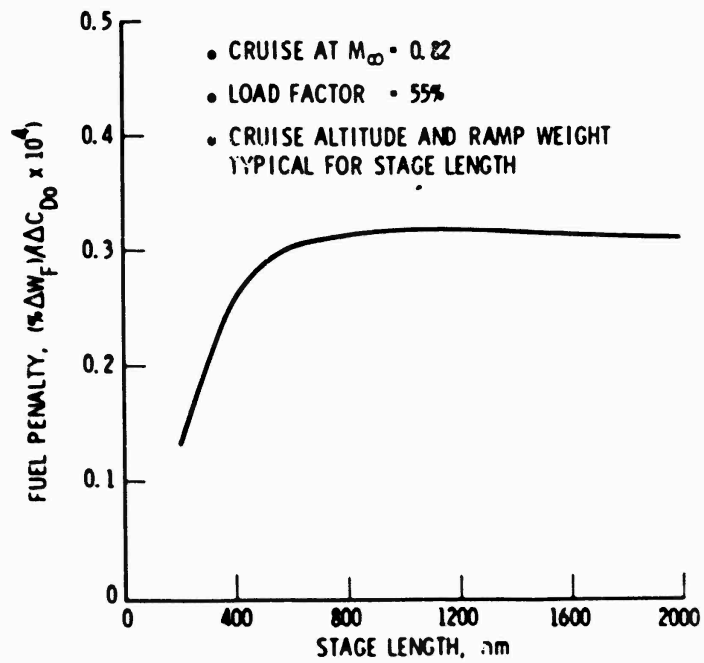

Figure 4. Sensitivity of Fuel Penalty to Stage Length for DC-10-10

the flight condition considered, the drag coefficient in cruise, C_{DCR} , is of the order 0.027 to 0.030. These values show that for large stage length a 1 percent increase in aerodynamic drag will produce about a 1 percent penalty in fuel burned, a result which is consistent with physical considerations. For stage lengths less than about 600 nm the fuel penalty is less since, as shown in Figure 1, a smaller percentage of the total fuel is burned in the climb-cruise segments of the flight profile.

Projection of Potential Fuel Savings. During the early phase of the IAMP, a thorough inspection and airframe discrepancy audit was performed on each DC-10-10 in the CAL fleet. This was accomplished using the previously described audit forms while each aircraft was in the maintenance hanger for a normal overnight check. Following accumulation of airframe discrepancy data, an estimated ΔC_{Do} and potential fuel savings were projected for each aircraft.

In developing ΔC_{Do} assessments, discrepancy subclasses were categorized according to repairability constraints to be imposed on maintenance actions undertaken during Task II. These constraints were imposed to maintain normal revenue service during flight verification and, in effect, limited the types of airframe repairs that could be performed in Task II. This, in turn, limited the total benefit of improved airframe maintenance that otherwise might be realized in a mature improved airframe maintenance program fully integrated with an airline's normal maintenance procedures.

In assessing airframe discrepancy repairability, discrepancies of the surface/seal irregularity class were divided into two categories. Category I discrepancies, considered repairable for purposes of the IAMP Task II, are those that can be routinely repaired, do not require substantial labor or special procedures for repair, and do not remove the aircraft from normal revenue service. Category I discrepancies were also chosen for their probability of remaining undamaged during Task II flight verification of fuel savings, which is an important factor in achieving a meaningful measure of pre- to post-repair savings. Category I discrepancies include door misalignments, leaking aerodynamic and passenger door seals, small skin dents, flap actuator fairing misalignments, and other

miscellaneous surface/seal irregularities. All rigging discrepancies were also considered to fall into Category I.

Category II discrepancies were defined as those which might easily be damaged during flight evaluation of fuel savings or which involve special procedures, substantial labor, and probable removal of the aircraft from revenue service for some period of time. Category II discrepancies include doubler type skin patches, paint damage over large surfaces, and cargo door seals. Cargo door seals are placed in Category II because of their vulnerability to damage during the flight evaluations of Task II. In effect, it was judged that new cargo door seal leaks that might occur during the flight data gathering periods would have less impact in perturbing the flight data if they occurred as an addition to existing cargo door seal leakage rather than as the initial leakage of new seals.

A summary of the ΔC_{D0} buildup for each aircraft is listed in Table 1 and shown graphically in Figure 5. Both the total ΔC_{D0} and the Category I ΔC_{D0} are of approximate uniform distribution, as indicated by their histograms shown in Figures 6 and 7 and their cumulative distributions shown in Figure 8. Referring to Table 1, it is seen that the Category I ΔC_{D0} is larger than the Category II ΔC_{D0} in all cases but three: aircraft 043, 053, and 054. A typical value of C_{DCR} for the DC-10-10 is approximately 0.027. Thus, the values of total ΔC_{D0} in Table 1 correspond to an aerodynamic drag penalty ranging from 0.2 to 1.1 percent.

The potential fuel savings corresponding to the ΔC_{D0} values of Table 1 are listed in Table 2 and shown graphically in Figure 9. These data are for a typical CAL DC-10-10 flight profile, which was determined from the data of Reference 8 to be a stage length of 1150 nm, with a 55 percent load factor. Cruise altitude was assumed to be 36,000 ft. The projected fleet average fuel savings due to all airframe discrepancies is 0.56 percent. The fuel savings due to Category I discrepancies only is 0.39 percent, while Category II discrepancies average 0.17 percent. These values represent theoretical upper limits on the potential fuel savings of the CAL fleet of DC-10's characterized by the discrepancy audit data of Table 1. In particular, it should be noted that the fleet would have to

Table 1. DC-10-10 Incremental Drag Summary, $\delta C_{Do} \times 10^4$

AIRCRAFT No.	041	042	043	044	046	047	048	049	050	051	052	053	054	055	056
SURFACE/SEAL IRREGULARITIES: CATEGORY I															
DOOR ADJUSTMENT	0.173	0.050	0.065	0.069	0.268	0.025	0.292	0.127	0.236	-	0.041	-	-	0.021	-
SEALS	0.226	0.166	0.272	0.058	0.126	0.014	0.132	0.222	0.175	0.140	0.167	0.094	0.020	0.045	0.001
DENTS	0.168	0.008	0.013	0.007	-	0.018	0.001	0.021	0.002	0.004	0.005	-	-	0.005	-
FLAP ACTUAT. FAIRINGS	0.300	0.019	-	-	-	0.022	-	0.018	-	0.132	-	-	-	-	0.176
OTHERS	0.108	-	0.120	0.074	0.001	-	-	-	0.036	0.073	-	-	-	-	0.004
SUBTOTAL: CATEGORY I	0.975	0.243	0.470	0.208	0.395	0.079	0.425	0.388	0.449	0.349	0.213	0.094	0.020	0.071	0.181
SURFACE/SEAL IRREGULARITIES: CATEGORY II															
PATCHES	0.710	0.521	0.791	0.687	0.261	0.110	0.229	0.025	0.224	0.067	0.223	0.024	0.281	0.344	0.181
PAINT	-	-	0.120	-	0.228	-	-	0.485	0.523	0.016	0.095	-	-	-	-
CARGO DOOR SEALS	-	0.086	0.054	-	0.336	-	-	-	0.217	0.244	0.217	0.705	-	0.113	0.141
SUBTOTAL: CATEGORY II	0.710	0.607	0.965	0.687	0.825	0.110	0.229	0.510	0.964	0.327	0.535	0.729	0.281	0.157	0.322
SUBTOTAL: SURFACE/SEAL IRREGULARITIES	1.685	0.850	1.435	0.895	1.220	0.189	0.654	0.898	1.413	0.676	0.748	0.823	0.301	0.228	0.503
MISRIGGED CONTROL SURFACES: CATEGORY I															
AILERONS	0.120	0.350	-	1.230	0.920	-	-	1.070	0.900	0.900	0.820	0.160	0.020	0.615	0.250
HORIZONTAL TAIL	0.050	-	0.070	0.230	0.250	-	0.015	0.240	0.400	0.018	0.160	0.165	0.045	0.550	0.400
FLAPS	0.060	0.010	0.050	0.025	0.008	0.130	0.020	0.240	0.130	0.270	0.030	0.030	0.055	0.018	0.120
SPOILERS	-	0.500	-	-	0.040	-	-	-	-	-	-	0.020	-	-	-
SLATS	0.050	0.040	0.050	0.040	0.015	0.160	0.010	0.330	0.010	-	0.045	0.038	0.025	-	0.016
SUBTOTAL: MISRIGGED CONTROL SURFACES: CATEGORY I	0.280	0.900	0.170	1.525	1.233	0.890	0.045	1.880	1.440	1.188	1.075	0.393	0.145	1.183	0.786
TOTAL $\Delta C_{Do} \times 10^4$: CATEGORIES I AND II	1.965	1.750	1.605	2.420	2.453	1.079	0.699	2.778	2.853	1.864	1.823	1.216	0.446	1.411	1.289
TOTAL $\Delta C_{Do} \times 10^4$: CATEGORY I	1.255	1.143	0.640	1.733	1.628	0.969	0.470	2.268	1.889	1.537	1.288	0.487	0.165	1.254	0.967

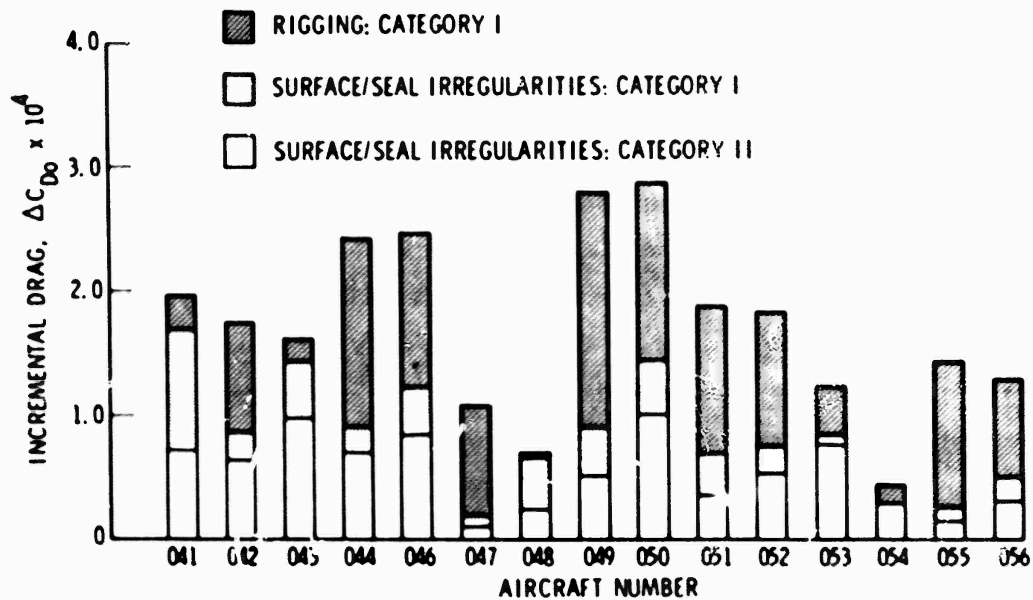

Figure 5. DC-10-10 Incremental Drag Summary

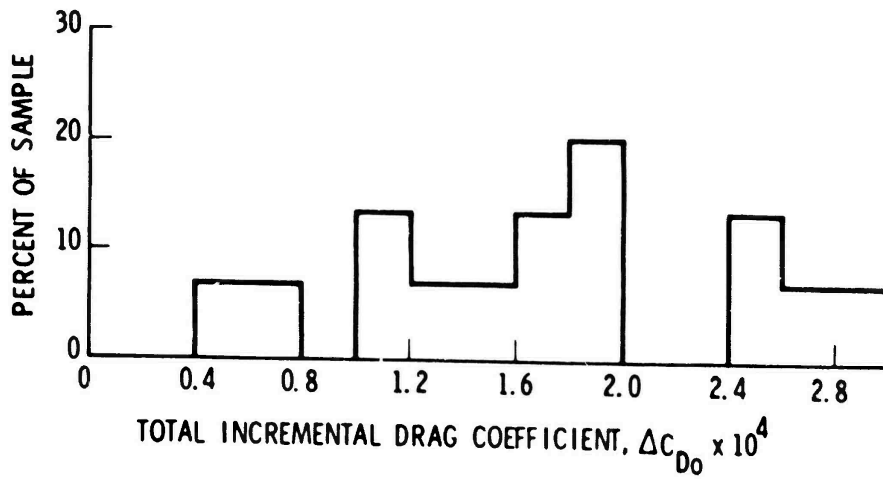

Figure 6. DC-10-10 Total Incremental Drag Histogram

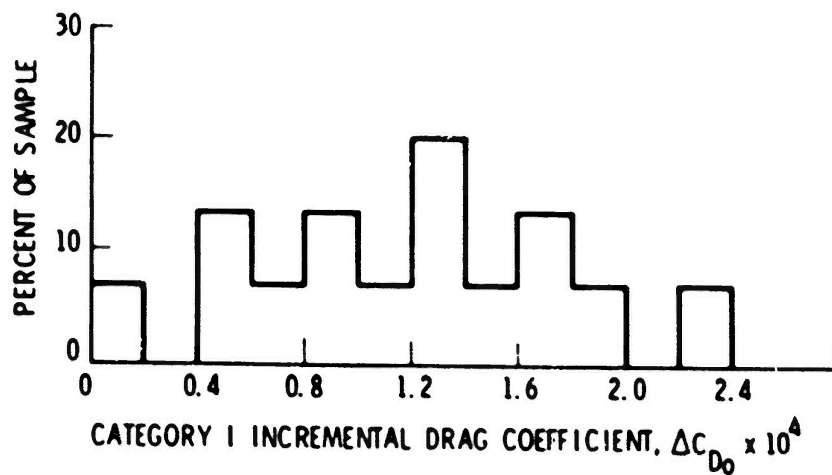

Figure 7. DC-10-10 Category I Incremental Drag Histogram

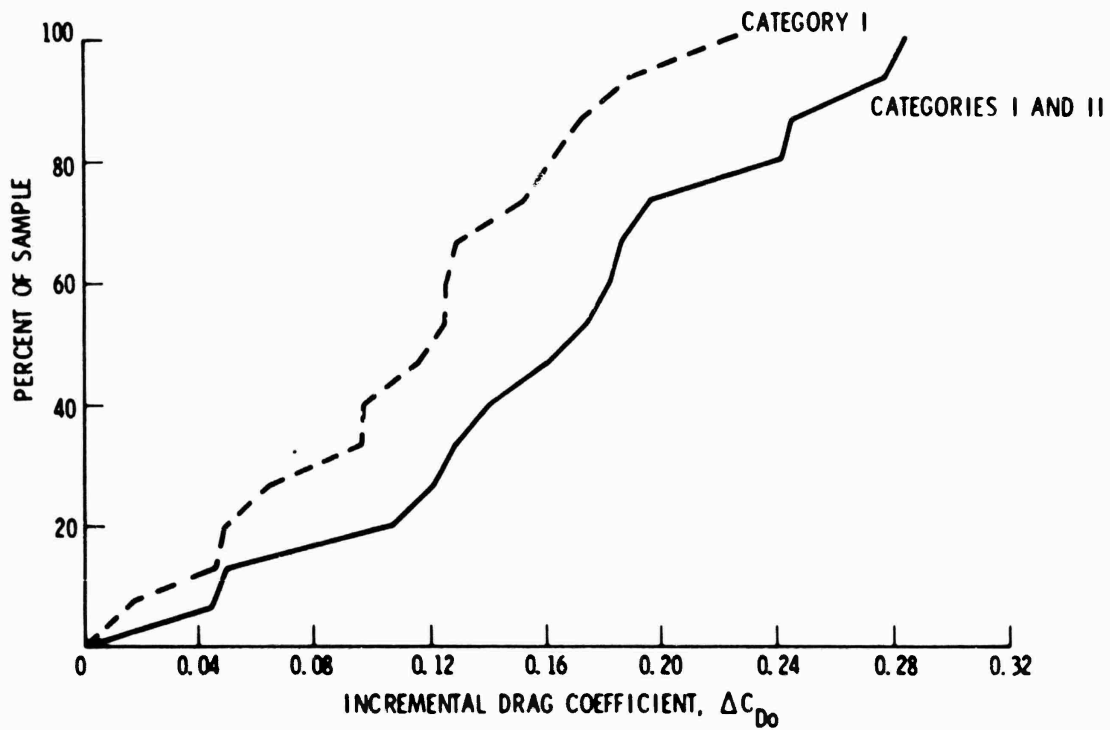

Figure 8. DC-10-10 Cumulative Distribution of ΔC_{Do}

Table 2. Potential Fleet Fuel Savings

AIRCRAFT	DISCREPANCY RELATED POTENTIAL FUEL SAVINGS, % w_f		
	CATEGORY I	CATEGORY II	CATEGORIES I AND II
041	0.409	0.231	0.640
042	0.373	0.198	0.571
043	0.208	0.315	0.523
044	0.565	0.224	0.789
046	0.531	0.249	0.800
047	0.316	0.036	0.352
048	0.153	0.075	0.228
049	0.739	0.166	0.905
050	0.616	0.314	0.930
051	0.501	0.107	0.608
052	0.420	0.174	0.594
053	0.159	0.238	0.397
054	0.052	0.082	0.134
055	0.409	0.051	0.460
056	0.315	0.105	0.420
POTENTIAL FLEET AVERAGE FUEL SAVINGS	0.305	0.173	0.558

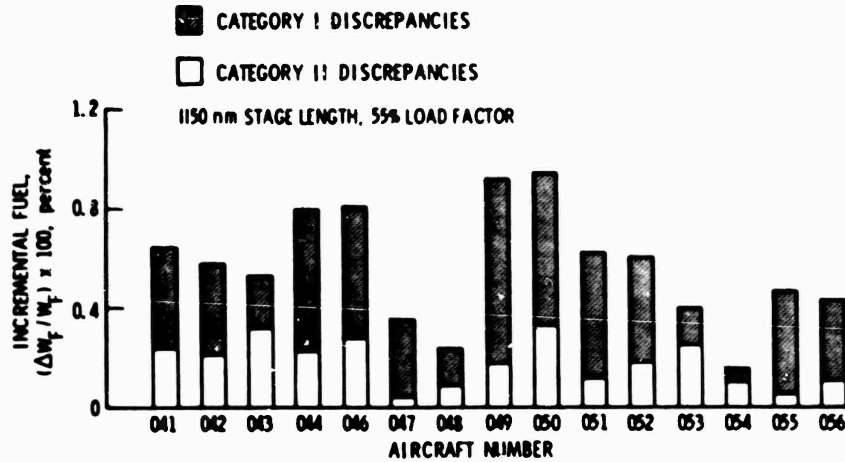

Figure 9. DC-10-10 Incremental Fuel Summary

be maintained in pristine condition, representative of the condition of new aircraft, to realize the combined potential fuel savings associated with removal of both Category I and II discrepancies. Also, it should be realized that these potential fuel savings have not been subjected to cost-benefit analyses, which remain as the final IAMP task.

TASK II: FLIGHT EVALUATION OF FUEL SAVINGS

In Task II of the IAMP, two CAL DC-10-10's were selected for the flight verification of fuel savings associated with improved airframe maintenance. Limitation of the flight verification phase of the IAMP to two aircraft allowed concentration of the funding budgeted for maintenance, data gathering, and statistical analyses, which maximized the probability of obtaining statistically significant flight test results. Selection of two aircraft also provided some insurance against an engine change or other unforeseen event that might totally ruin the baseline or post-maintenance data base. While this approach maximizes the chance of obtaining statistically significant results for one or two aircraft, it does not provide enough information to measure the fleet average

improvement in fuel consumption resulting from airframe maintenance. However, the data generated in Task I provide estimates of these measures and, when verified by statistically significant flight test results, can provide an indication of the potential fleet fuel savings that are available through improved airframe maintenance.

In implementing Task II, the selected aircraft were flown in normal revenue service to establish measures of performance indicative of their baseline drag and fuel consumption. The aircraft were then subjected to an airframe reaudit to identify any new airframe discrepancies which the aircraft might have incurred since the original audit. Following reaudit, all Category I airframe discrepancies were repaired and the aircraft were returned to normal revenue service where data were collected to establish the post-repair performance of the aircraft. At the end of the post-repair data acquisition period, another check of the airframes was accomplished to verify that no major airframe discrepancies had been incurred that would compromise the flight data. Multivariable regression analyses were then performed on the pre- and post-maintenance data sets to establish statistical assessments of the measured improvement in aircraft drag and fuel consumption. It should be emphasized that all Task II flight data were collected in normal revenue service and that no significant compromise was made in aircraft operations. While this approach has the virtue of providing data on a "real world" basis, it does preclude the use of special instrumentation or specially controlled flight procedures that might increase the accuracy of flight measurements. Measurement accuracy is, of course, crucial because the expected fuel savings are of the order of 0.5 percent, while years of flight test experience have shown that even under controlled conditions with specialized instrumentation, accuracy bands of ± 2 percent and larger are typically obtained. In light of this situation, special procedures in aircraft selection, flight data processing and analysis, and program control were established to maximize the probability of discriminating a pre- to post-maintenance drag and fuel change in the flight verification phase.

Aircraft Selection. The primary factor that affected aircraft selection for flight verification in Task II of the IAMP was the magnitude of ΔC_{Do} for Category I, or Task II repairable airframe discrepancies. The initial candidates were, therefore, aircraft numbers 044, 046, 049, 050 and 051, which are the aircraft in Table 1 having the largest Category I values of ΔC_{Do} . The two aircraft finally selected from this list were aircraft 046 and 049. Factors in addition to ΔC_{Do} that ultimately entered the selection process were related to the impending sale of certain aircraft, scheduled engine changes, and the balance between surface/seal irregularities and discrepancies involving out-of-rig control surfaces.

Flight Data Acquisition. Flight data were collected on the two IAMP verification aircraft for periods of 2-1/2 months prior to and following maintenance to correct the Category I airframe discrepancies listed in Table 1. Data were collected by the flight crew during stabilized cruise flight at the nominal rate of once per flight segment. This was accomplished by disengaging the autothrottles and autopilot, trimming the aircraft, and allowing it to come to a stabilized flight condition defined by constant velocity and horizontal flight path, prior to the recording of flight data. In stabilized flight, the aircraft is in static equilibrium. Lift, L , is equal to the aircraft weight, W , and the net engine thrust, F_N , is equal to the aerodynamic drag, D . The aircraft instrument readings used to characterize these conditions were indicated Mach number M_1 , indicated pressure altitude, h_1 , indicated total air temperature, T_{T1} , indicated engine fan speed, N_{11} , indicated fuel flow, W_{F1} , and aircraft weight, W , determined as the difference between the ramp weight and the weight of fuel burned to the time of data acquisition.

In the pre-maintenance period, 109 data points were recorded for aircraft 046, and 108 data points were recorded for aircraft 049. The post-maintenance sample sizes were significantly less due to an airline flight attendants' strike, which severely reduced the flight frequency of the CAL DC-10-10 fleet. In the post-maintenance period, 69 data points were recorded for aircraft 046, and 54 data points were recorded for

aircraft 049. Statistical analyses performed prior to initiation of the IAMP, using observed values of data scatter and accuracies of the flight instrumentation, indicated that a minimum sample of about 40 points would be required in order to obtain flight verification results with the desired level of statistical confidence. Based on this assessment, it was concluded that the smaller post-maintenance sample sizes would not significantly compromise the flight verification phase of the program.

Flight Data Processing. The raw flight data collected by the flight crew were processed by the CAL Cruise Audit Program, which is a computer program using a core deck developed by the Douglas Aircraft Company (DAC). This program is routinely used by CAL to monitor the long term performance of their DC-10-10 fleet. The Cruise Audit Program computes aircraft and engine performance from the indicated instrument readings recorded in stabilized flight and compares them to standard DC-10-10 performance manual values for the recorded flight condition. Program output variables used to monitor aircraft performance are given as percentage deviations from their corresponding manual values. Output variables of interest for the purpose of analyzing fuel savings due to improved airframe maintenance are the percentage deviation in net engine thrust, ΔF_N , and the percentage deviation in engine fuel flow, $\Delta \dot{W}_F$, as defined in Equations (2) and (3).

$$\Delta F_N = F_{Ni} - F_{Nm} \quad (2)$$

$$\Delta \dot{W}_F = \dot{W}_{Fi} - \dot{W}_{Fm} \quad (3)$$

In Equations (2) and (3), the m subscripts refer to manual values and the i subscripts refer to quantities derived from indicated instrument readings. In the Cruise Audit Program, the value of F_{Nm} in Equation (2) is obtained from the relationships of Equations (4) and (5), which are valid for stabilized flight.

$$W = L = 0.7\delta M^2 P_{SL} S C_L \quad (4)$$

$$F_N = D = 0.7\delta M^2 P_{SL} S C_D \quad (5)$$

In Equations (4) and (5), δ is the ratio of pressure at altitude to that at sea level, P/P_{SL} , S is the aircraft's wing area, and C_L and C_D are the aircraft lift and drag coefficients, respectively. To determine F_{Nm} , the Cruise Audit Program first determines the lift coefficient from Equation (4) using the indicated values of Mach number and pressure altitude and the computed value of aircraft weight recorded by the flight crew. The value of the drag coefficient corresponding to the calculated value of C_L is then extracted from performance manual data stored in the computer. These data relate values of C_D to values of C_L as a function of W , δ , and M . The value of F_{Nm} is then computed using Equation (5). Finally, ΔF_N is computed by entering the calculated value of F_{Nm} into Equation (2) along with the performance manual value of F_{N1} , which is stored in the computer as functions of M , N , δ , and $\theta = T_o/T_{oSL}$, the ratio of ambient to sea level static temperature.

The value of $\Delta \dot{W}_F$ in Equation (3) is computed in the Cruise Audit Program by using the value of \dot{W}_{F1} , recorded by the flight crew, and the computer stored performance manual value of \dot{W}_{Fm} as a function of M , δ , N_1 , and $\theta_T = T_T/T_{TSL}$, the ratio of ambient to sea level total temperature, all of which are recorded by the flight crew. Figure 10 presents a flow diagram of the Cruise Audit Program calculations detailed above.

Analysis of Flight Data. At a specified weight and stabilized flight condition the true aerodynamic drag of the aircraft is represented by the value of F_{N1} since that is a measure of the actual level at which the engines are working to overcome aerodynamic drag. F_{Nm} is determined from the performance manual as a unique function of W , δ , and M . Thus, at the same flight condition, if as a result of corrective maintenance there is a reduction in aerodynamic drag, the post-maintenance F_{N1} will be reduced in direct proportion to the reduction in C_D while the post-maintenance F_{Nm} will remain unchanged. The difference between the pre- and post-maintenance ΔF_N will then define the aerodynamic drag changes which have been

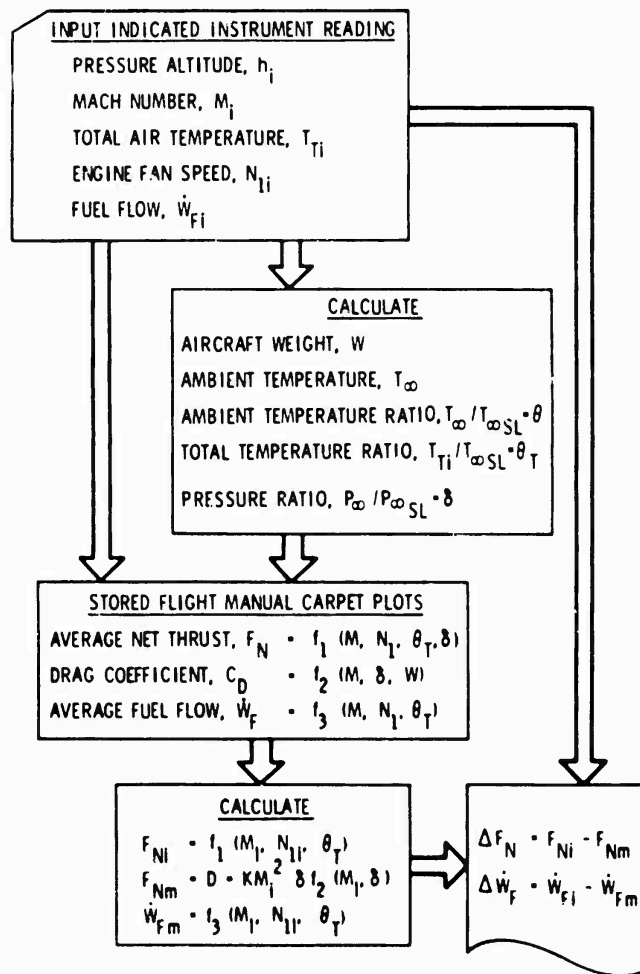

Figure 10. Flow Diagram of Thrust and Fuel Flow Segment of Cruise Audit Program

achieved through improved airframe maintenance, according to the relationships of the following equations:

$$\begin{aligned} \Delta F_{Npost} - \Delta F_{Npre} &= F_{Ni,post} - F_{Nm} - F_{Ni,pre} + F_{Nm} \\ &= F_{Ni,post} - F_{Ni,pre} \end{aligned}$$

$$\Delta F_{Npost} - \Delta F_{Npre} = D_{post} - D_{pre} \quad (6)$$

Equation (6) is based on the assumption that the relationship between net engine thrust and fan speed remains invariant over the data acquisition period. Generally this is true unless an unusually serious deterioration of the burner section and/or the gas turbine blades occurs, or if there is deterioration in the fan section. In the event of a serious deterioration of the burner section and/or gas turbine blades, there will be a second order variation of net engine thrust and a first order variation in fuel flow with fan speed. Thus, by monitoring the pre- and post-maintenance $\dot{\Delta W}_F$, the stability of the engine over the total period of data acquisition can be monitored and if any significant post-maintenance deviation is noted, its effect on the incremental drag, computed from Equation (6), can be assessed. If necessary, corrections to the pre- to post-maintenance drag assessment can then be developed from performance manual data.

Statistical Analysis of Cruise Audit Data. To enhance accuracy in estimating pre- to post-airframe maintenance improvements in the aerodynamic drag and fuel consumption of the IAMP verification aircraft, a multivariable linear regression analysis was performed. This was accomplished by using the Cruise Audit Program output thrust and fuel flow rate deviation data with the program input data recorded by the flight crew as the respective dependent and independent regression variables. In the analysis, engine thrust deviation, ΔF_N , was expressed as a function of the sum of linear and quadratic terms in aircraft indicated Mach number, M_1 , weight, W , indicated pressure altitude, h_1 , indicated total air temperature, T_{T1} , indicated engine fan speed, N_{11} , and time, t , in terms of flight sequence. Average and individual engine fuel flow rate deviation was expressed as a function of the same variables with the addition of linear and quadratic terms in applicable indicated engine fuel flow rates, \dot{W}_{F1} . Using these data, least-square error equations were developed to relate the Cruise Audit Program output variables of thrust deviation, three-engine average fuel flow rate, and individual fuel flow rate to

statistically significant independent variables of their respective regression models.

Notably different results were obtained from the regression analyses for the two IAMP verification aircraft. At the centroid of its recorded flight data, aircraft 046 was found to have a 0.40 percent reduction in post-maintenance thrust deviation at a confidence level in excess of 98 percent, with limits of 0.08 to 0.72 deviation percent at the 95 percent level of confidence. The post-maintenance fuel flow rate deviation was found to be 0.13 percent greater than the pre-maintenance value with limits of 0.04 to 0.22 deviation percent at the 95 percent level of confidence. This measured increase in $\Delta \dot{W}_F$ of aircraft 046 is typical of normal in-service engine deterioration and is of sufficiently small magnitude to have essentially no effect on net engine thrust. Thus, the 0.40 percent decrease in thrust deviation obtained from the regression analysis is interpreted as a 0.40 percent reduction in aerodynamic drag resulting from the correction of airframe discrepancies. The estimated drag reduction based on the physical audit of aircraft 046 is 0.60 percent. Thus, the predicted value of drag reduction falls within the 95 percent confidence band of the flight verification data.

In contrast to these results, the regression analysis of aircraft 049 showed no statistically significant change in pre- to post-maintenance thrust and fuel flow deviation. From a statistical viewpoint there is insufficient evidence to reject the hypothesis that the means of the pre- and post-maintenance data samples are the same. Without a method of evaluating data quality, the inconclusive results obtained with aircraft 049 would have to be attributed to one or more factors, including a too small sample size, a difference in the means which is small compared to the standard deviation of the data, or poor quality data. However, examination of Cruise Audit Program output data indicates that the inconclusive results obtained on aircraft 049 are due to poor quality flight data obtained in the post-maintenance phase of the verification tests. This conclusion is based on an examination of the data quality index, Q, a Cruise Audit Program output that monitors data quality by measuring the degree to which the aircraft was stabilized in equilibrium

flight at the time of data acquisition. The variable Q is defined as the sum of percentage deviations from performance manual values in engine thrust, fuel flow rate, and specific range. Inspection of this parameter shows that a large percentage of the post-maintenance data for aircraft 049 was taken when the aircraft was not adequately stabilized. Histograms of Q for both aircraft 046 and 049 are shown in Figure 11. A small value

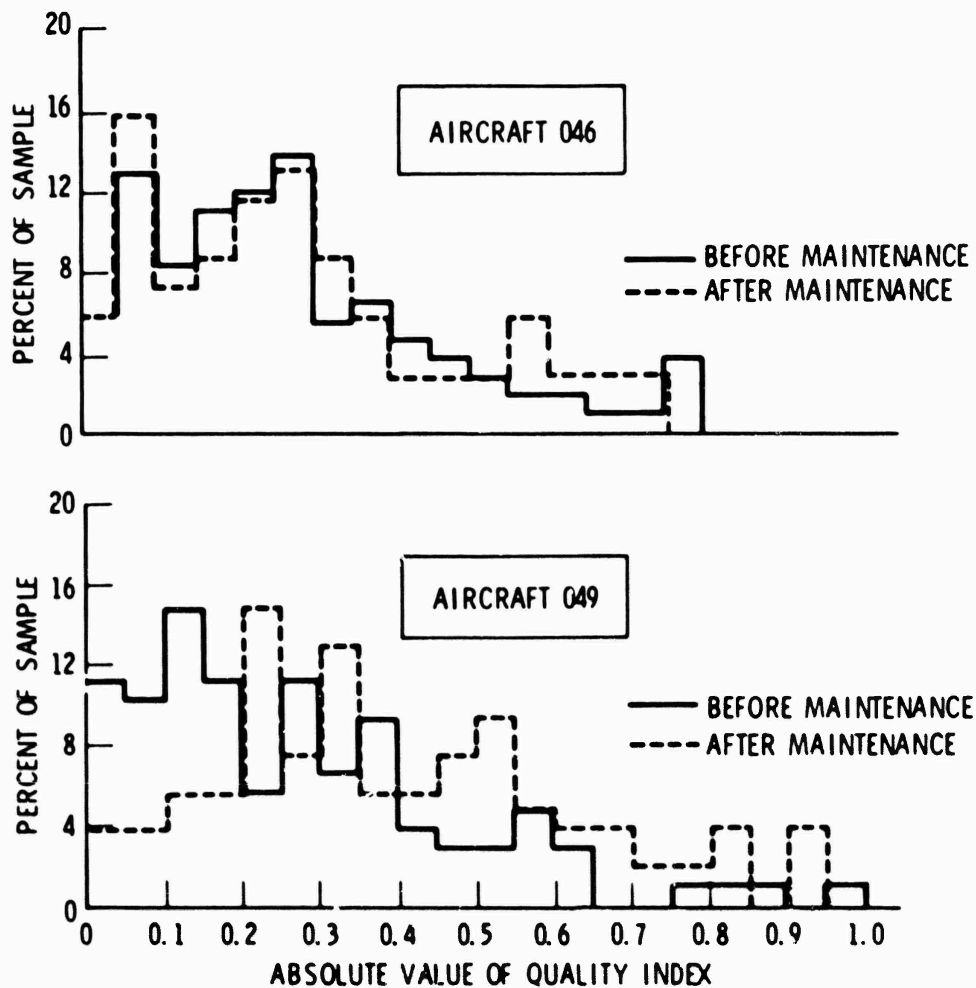

Figure 11. Cruise Audit Program Quality Index Histograms

of Q indicates a stabilized flight condition, and a Q greater than about 0.5 indicates data of questionable quality. For all data sets except the aircraft 049 post-maintenance set, the bulk of the data is in the low Q region. The aircraft 049 post-maintenance histogram shows a dearth of good quality data with Q less than 0.20 and significant amounts of poor quality data with Q larger than 0.45. The cumulative distribution curves of Q shown in Figure 12 for the four data samples further demonstrate the anomalous behavior of the aircraft 049 post-maintenance data set. The median value of Q for aircraft 049 is 0.34, while the median value for the other three data sets varies from 0.22 to 0.26. Thirty-six percent of aircraft 049 post-maintenance data have a Q value greater than 0.45, while only 16 to 20 percent of the data of the other sets have Q values of this magnitude. Unstabilized flight as the explanation for the low quality

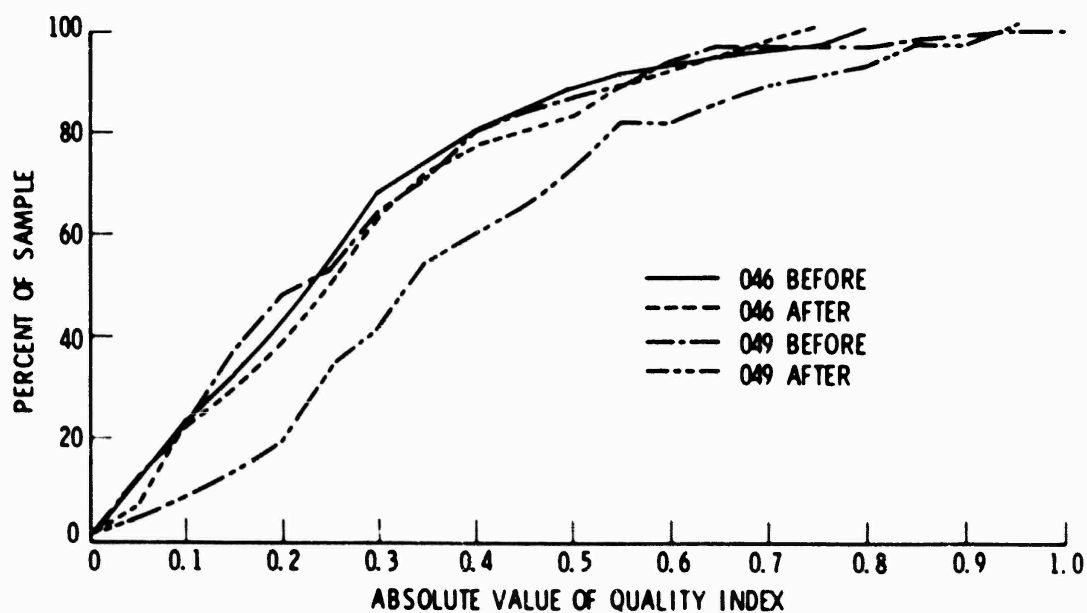

Figure 12. Cruise Audit Program Quality Index Cumulative Distribution

data is further supported by an examination of the regression analysis curve fit for aircraft 049, which shows anomalous behavior for the variation of post-maintenance thrust deviation with Mach number and total temperature, but not with any of the other independent variables used in the curve fit. This is especially significant since Mach number and total temperature are the two variables which would be very sensitive to unstabilized flight. The block of poor quality data may have resulted from frequent operation during turbulent winter months on overland routes as opposed to operation over the smoother Pacific routes.

SUMMARY AND CONCLUSIONS

The key results of the Improved Airframe Maintenance Program obtained to date are briefly summarized as follows.

- o Based on a physical airframe audit and analytical assessment of each of 15 DC-10-10's in the CAL fleet, the estimated total incremental drag penalty due to airframe discrepancies was found to vary from a minimum of 0.17 percent to a maximum of 1.06 percent and to be distributed in an approximate uniform manner within this range. The fleet average incremental drag was 0.63 percent. For Category I type discrepancies only, the drag penalty was found to be uniformly distributed over the range of 0.06 percent to 0.84 percent, with a fleet average of 0.44 percent. The corresponding projected fleet average fuel penalties are 0.56 percent when all discrepancies are considered and 0.39 percent for the Category I only type discrepancies.

- o The drag reduction resulting from improved airframe maintenance was measured with a level of confidence in excess of 98 percent on one DC-10-10 in normal revenue service and found to be 0.40 percent with limits of 0.08 to 0.72 percent at the 95 percent level of confidence. The drag reduction based on the physical audit of this aircraft was estimated to be 0.60 percent. The measured drag reduction of 0.40 percent is approximately equal to a 0.40 percent reduction in fuel consumption. The results on a second test aircraft were inconclusive due to poor data acquired in the post-maintenance flight verification phase of Task II. The poor quality of the post-maintenance data sample is attributed to a large number of readings taken under turbulent flight conditions.

Based on these results, it is concluded that improved airframe maintenance has produced a measurable improvement in the fuel consumption of a commercial jet airliner in normal revenue service.

FUTURE WORK

The single remaining IAMP task is performance of a cost-benefit analysis. In this analysis, the future value of fuel savings resulting from the correction of airframe discrepancies will be discounted to present value and equated to current maintenance costs to define the breakeven period for a given maintenance action. The results, to be published in the IAMP final report, will present a set of curves relating months to breakeven as a function of rate-of-return on a maintenance investment for a range of values of a variable defining the ratio of maintenance to fuel costs. Each curve will represent a distinct value of incremental drag. These curves, in conjunction with assessments by the airlines of the mean lifetime of a given airframe repair based on their maintenance records, and incremental drag, using methods developed in the IAMP, will allow selection of candidate airframe maintenance actions that are economically viable based on potential fuel savings alone.

REFERENCES

1. "Douglas Service - Special Supplement, DC-10 Series 10 Fuel Conservation," Volume XXXV (October 1978).
2. Lockheed TriStar Service Digest (October-December 1976).
3. "Airplane Maintenance for Fuel Conservation for Boeing 707/727/737/747 Jet Transports," Boeing D6-42858 (January 1976).
4. Bertelrud, A., "Roughness Effects on Fuel Consumption for Two Commercial Aircraft-McDonnell Douglas DC-9 and DC-10," Aeronautical Research Institute of Sweden, FFA AU-1456 (October 1979).
5. Covey, R. R., Mascetti, G. J., and Roessler, W. U., "Examination of Commercial Aviation Operational Energy Conservation Strategies," The Aerospace Corporation, ATR-79(7761)-1 (October 1978).

6. Fluid Dynamic Drag, S. F. Horner, 148 Busted Drive, Midland Park, New Jersey (1958).
7. Garrido, A. A., "Performance of the DC-10 Series Jet Transport Powered by Three General Electric CF6-6D Engines," McDonnell Douglas Report No. MDC J5307/01 (October 1971).
8. "Aircraft Operating Cost and Performance Report for Calendar Years 1978 and 1979," Bureau of Accounts and Statistics, Civil Aeronautics Board, Washington, D.C. (July 1979).

DEVELOPMENT OF A PROCEDURE FOR CALCULATING THE
EFFECTS OF AIRFOIL EROSION ON AIRCRAFT ENGINE
COMPRESSOR PERFORMANCE

O. J. McMillan
Nielsen Engineering & Research, Inc.

PRECEDING PAGE BLANK-NOT FILMED

INTRODUCTION

That aircraft turbine engine performance deteriorates as engine time increases has long been recognized. In the days of cheap fuel, the small economic penalty of this deterioration did not merit much attention, and maintenance strategies on the part of the airlines using the engines could be relatively straight-forward. However, the recent (and continuing) rapid increases in fuel costs have made the operating expenses associated with this performance deterioration so large that more sophisticated methodologies are required. Maintenance decisions made by the airlines must be placed on a firmer, more rational ground to allow the proper trade-offs to be made between continued operation of a deteriorated part with its associated high operating costs and the replacement/refurbishment of the part with its associated front-end costs but lower operating costs.

A typical history of the fuel consumption for an aircraft turbine engine is shown in figure 1. There is typically a small, rapid, initial increase in the engine's fuel consumption when it is first installed in the aircraft, followed by a continued further gradual deterioration. It is this gradual long-term deterioration that is at least partially recoverable through proper maintenance, and which must be traded off against the costs of this maintenance.

The short- and long-term deterioration of the performance of two of the high-bypass turbofan engines most in use today (the JT9D and CF6 engines) have been studied in NASA's Aircraft Energy Efficient (ACEE) program (see, for example, refs. 1 and 2). Much has been learned in this program, and it has been concluded that a considerable portion of the long-term deterioration in these high-bypass-ratio engines is cost effective to recover. In this program, it has been shown that the long-term increase in fuel consumption is due to a degradation in performance throughout the engine. For example, figure 2 shows the increase in specific fuel consumption for a JT9D engine after 3000 flights broken down by engine component. It is seen that the increase in fuel consumption due to the fan, the low-pressure compressor (LPC), the high-pressure compressor (HPC), the high-pressure turbine (HPT) and the low-pressure turbine (LPT) are all important. It has further been shown that the deterioration in the performance of each of these components is due to a combination of clearance increases between the rotating parts and their stationary shrouds, increases in seal leakage, increased surface roughness (particularly on the rotating parts), and changes in shape of the component parts due to erosion (again, mostly concentrated in the rotating parts). The relative importance of these various mechanisms depends on the particular component involved.

While much has been learned about these high-bypass-ratio engines, there has been no similar program for the ubiquitous low-bypass turbofan, the JT8D. Although this engine has been in service since 1964, its use in the Boeing 727 and 737, the McDonnell Douglas DC-9, the Dassault-Brequet Mercure and in the -10 versions of the Aerospatiale Caravelle assures its presence for years to come, and maximizing the fuel efficiency through proper maintenance of these high-service-time engines is of obvious importance. While some of the overall knowledge gained in the NASA program for the high-bypass engines carries over to the JT8D, many of the specifics do not. For example, it is not known for the JT8D just how much of an increase in fuel consumption is associated with a particular amount

of a particular kind of geometry change in the engine; it is just this kind of information that is essential to the airlines if their maintenance strategies are to be improved.

In this paper, a research program aimed at partially redressing this problem is described. This program involves the development of a procedure to allow the detailed assessment of the effects of fan or compressor airfoil erosion on JT8D fuel consumption. In this paper, emphasis is placed on the first step in this development process, now being carried out under contract to the Department of Energy. The procedure, when completed, will be a valuable tool to be used in the process of determining the most cost-effective way of maintaining the JT8D throughout the many years remaining of its useful life.

OVERALL PROGRAM

The ultimate aim of this program is the synthesis of a number of existing computational methods to allow the calculation of the effects on JT8D fuel consumption of observed changes in blade shape in the fan and compressor sections. Envisioned in the program are some carefully selected experimental studies to calibrate and verify the computational methods. The overall research program can be viewed as consisting of three parts.

- A. The integration of existing computational procedures into a system that will allow the assessment of the effects on fan and compressor performance of changes in the airfoil shapes in these components.
- B. A series of cascade, compressor and engine tests to provide calibration and verification of this computational system as well as its individual computational elements.
- C. Engine cycle analyses to translate the calculated component performance into engine fuel consumption in a series of parametric studies to define erosion areas with large impact on operating cost.

Part A of this program is addressed by the ongoing study funded by DOE which will now be described in more detail; parts B and C remain for future work.

COMPUTATIONAL TOOLS

The analysis scheme used is a simplification of the conventional quasi-three-dimensional steady-flow approach. In the conventional approach, the two-dimensional calculation of the flow on a hub-to-tip surface approximating a mean stream surface in the blade passages is iteratively coupled to a two-dimensional blade-to-blade solution on a series of axisymmetric surfaces. By carrying this iterative procedure to convergence, a prediction of blade-element and overall compressor performance results. In the simplified procedure, the blade-to-blade solution at each iteration is replaced by empirically based correlations of blade-element performance; the combination of a detailed solution in the hub-to-tip surface and blade-element performance provided by correlations is termed a "throughflow" analysis. However, we retain the use of a detailed blade-to-blade solution procedure to contrast the performance of eroded blade elements to the performance of the same elements when they were new. As discussed below, by deriving one converged solution from the throughflow analysis for "all

new" geometry, and another with the blade-element performance from the correlations modified in accord with the changes in the detailed blade-to-blade analysis in going from "new" to "eroded" blades, an estimate of the effect on compressor performance of the particular blade-shape change selected is arrived.

The code used to solve the flow on the hub-to-tip stream surface (the "throughflow" program) is that described in ref. 3. In this code, the conditions of radial equilibrium are established at each computing station in turn, where the computing stations are a series of surfaces spaced axially in the flow intersecting the hub and tip contours. At each station, radial equilibrium is established by adjusting the radial position of the set of streamlines being calculated. For a computing station downstream of a stator or rotor, the influence of the blading on the analysis is taken from correlations of blade-element performance applied at each streamline position. A series of "sweeps" through the compressor is made until the maximum radial change in streamline position at each station from one sweep to the next is less than some specified tolerance. The blade-element performance correlations are mostly derived from ref. 4, although some extensions of that work have been incorporated.

To allow a detailed determination of the effects of shape change on blade-element performance, the blade-to-blade scheme (the "cascade" program) of reference 5 is used. This scheme incorporates an inviscid-viscous flow field interaction method for the computation of fluid turning and loss characteristics of an arbitrary airfoil cascade. The flow may be compressible, and axial velocity-density product and stream surface radius changes are permitted. The inviscid analysis is that of ref. 6. The boundary layer program used is a revision of the differential method described in ref. 7. Laminar, transitional and turbulent boundary layers are allowed; when turbulent flow is attained, an algebraic eddy viscosity is used. Allowance is made in the inviscid analysis for the displacement effect of the boundary layers by means of injecting fluid along the airfoil surfaces. The iterative interaction procedure developed in ref. 5 is designed to lead to matched viscous and inviscid solutions in an economical manner.

ANALYSIS PROCEDURE: BLADE-SHAPE EFFECT ON COMPRESSOR PERFORMANCE

The following procedure makes use of the computational methods just described to calculate the effects of blade-shape changes on compressor performance.

1. The elements of compressor geometry necessary as input to the throughflow and cascade programs are ascertained. This includes measurements of "new" compressor geometry, including blade sections, and the measurement of "used" blade sections. The used-blade measurements are examined and a representative set of eroded sections are chosen for further study.
2. The throughflow program is run for the new compressor geometry.
3. The cascade program is run for the blade sections selected for study in step 1; a run is made for these sections in the "new" condition to establish baseline cascade performance, and then

another with the sections in the eroded condition. Changes in turning and losses are calculated from the cascade analysis for the eroded condition relative to the new condition.

4. The changes in section performance calculated in step 3 are used in another run of the throughflow program for the compressor containing the eroded sections.
5. Changes in compressor performance associated with the selected blade-shape changes are calculated from the results of the throughflow program run of step 4 measured relative to the baseline run of step 2.

This procedure is being demonstrated in the current contract work with DOE. At this point, we have completed all of the geometry measurements, including determination of blade sections in the "new" and "used" conditions. We are currently preparing the input for runs of the throughflow and cascade programs. The measurement program has been done with the generous cooperation of United Airlines Maintenance Operations at San Francisco International Airport, which has allowed access to JT8D-7 hardware and the use of their contour tracing machine. In the remainder of this paper, we will present some sample results of this measurement program.

BLADE SECTION MEASUREMENTS

To determine the blade-section characteristics in the "new" condition, we have measured 3 sections per blade (hub, midspan, and tip) for sample blades from stages 3 through 13. For the longer fan blades, stages 1 and 2, we have also measured sections at two intermediate locations along the blade. Because the new blades do exhibit some variability due to tolerances in the manufacturing process, we have further measured several samples of each section of each stage. Figure 3 is an example of the results of this process, showing the variability at the tip section of new third stage rotor blades. Tracings of ten blade samples have been overlaid in this figure. Also shown in figure 3 is the estimated uncertainty (0.002") in our measurement procedure in locating a given blade surface.

The variability in the surface tracings shown in figure 3 naturally leads to some variability in the section characteristics inferred from these tracings. Figure 4 illustrates this for the camber and thickness distributions deduced from the new third stage rotor blades we measured. The values of the individual blade samples are shown as a function of distance along the blade axis along with a line representing the average distribution.

The observed variability in new-blade section characteristics (samples of which were shown in figures 3 and 4) is certainly not small. In fact, the observed changes in profile for high-cycle eroded blades at some locations in the engine are of the same order as the new-blade sample-to-sample variability. It turns out that the third stage rotor is such a location; a typical eroded third-stage tip section is shown in figure 5 compared to the envelope of new-blade shapes taken from figure 3. The chord is reduced by some leading-edge erosion, but the remainder of the blade falls within the envelope of "new" contours. Of course, there are locations in the engine where the change in shape exhibited by eroded blades is considerably greater than the sample-to-sample variability shown

for new blades. An example of this situation is shown in figure 6, where the tip section of an eroded thirteenth-stage rotor blade is compared to the envelope measured for new blades. A considerable "uncambering" is evident at this section due to erosion at both the leading and trailing edges.

Using the analysis procedure described in the preceding section, it will be possible to investigate the sensitivity of compressor performance to the various levels of changes observed in blade shapes at the various locations in the engine. When coupled to the experimental verification and cycle-analysis steps indicated in the description of the Overall Program, this procedure will form a tool which should be of great usefulness in estimating the cost effectiveness of candidate maintenance procedures.

SUMMARY

A research program has been described which will result in a procedure to assess in detail the effects of fan or compressor airfoil erosion on JT8D fuel consumption. The first step in this program (currently ongoing) combines an existing throughflow program with results obtained from an existing combined viscous-inviscid blade-to-blade analysis to determine the effects on JT8D compressor performance of changes in fan or compressor blade shape. Samples of JT8D blade sections under "new" and "eroded" conditions obtained in this program have been presented. It has been shown that although the new blades have sample-to-sample variability that is easily apparent and of the same order as changes in blade shape caused by erosion in some locations in the engine, much larger changes in blade shape are caused by erosion in other locations. The way in which the procedure being developed will be used to ascertain the sensitivity of the compressor performance to these various levels of blade-shape change in the different locations has been described.

ACKNOWLEDGMENTS

The work described in this paper has been supported by DOE contract DE-AC03-79CS50095. The generous cooperation of United Airlines Maintenance Operation in making their facilities available for the blade measurement program is much appreciated.

REFERENCES

1. Sallee, G. P.: Performance Deterioration Based on In-Service Engine Data. NASA CR-159525, April 1979.
2. Wulf, Ray. H.: CF6-6D Engine Performance Deterioration. NASA CR-159786, January 1980.
3. Hearsey, R. M.: HT0300 - A Computer Program for the Design and Analysis of Axial Turbomachinery, Parts I and II. Dynatech R/D Company, March 1970.
4. Aerodynamic Design of Axial-Flow Compressors, edited by I. A. Johnsen and R. O. Bullock, NASA SP-36, 1965.
5. Hansen, E. C., Serovy, G. K. and Sockol, P. M.: Axial-Flow Compressor Turning Angle and Loss by Inviscid-Viscous Interaction Blade-to-Blade Computation. ASME Paper No. 79-GT-5, March 1979.

6. Katsanis, T. and McNally, W. D.: FORTRAN Program for Calculating Velocities and Streamlines on a Blade-to-Blade Stream Surface of a Tandem Blade Turbomachine. NASA TND-5044, 1969.
7. Albers, J. and Gregg, J.: Computer Program for Calculating Laminar, Transitional, and Turbulent Boundary Layers for a Compressible Axisymmetric Flow. NASA TND-7521, 1974.

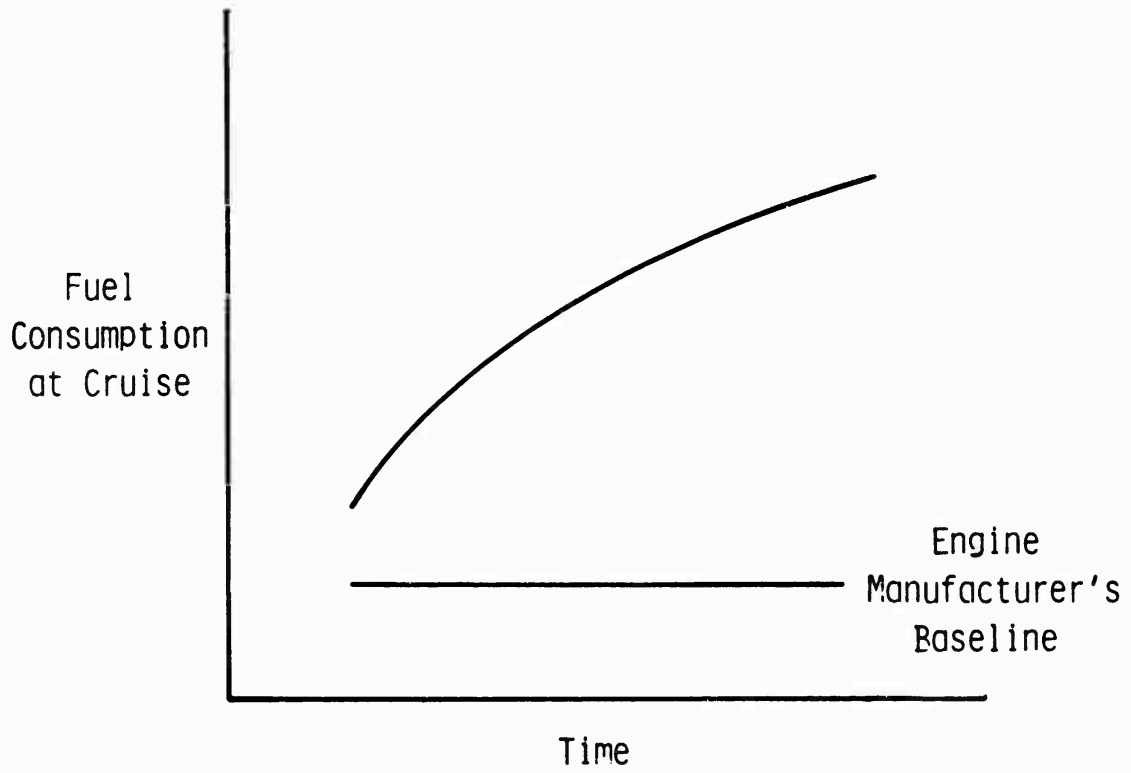

Figure 1.- Increase in fuel consumption with time for a typical aircraft engine

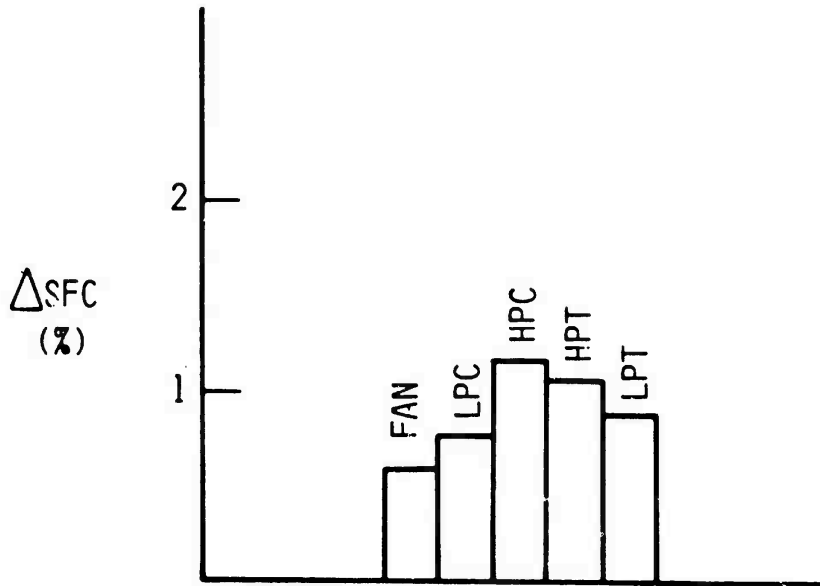

Figure 2.- JT9D Long-term Component Performance Deterioration (from ref. 1)

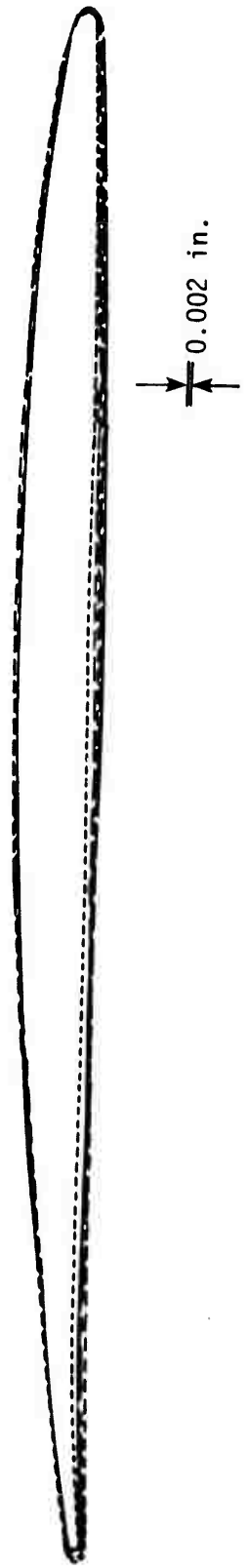

Figure 3.- Stage 3, tip section, new blades

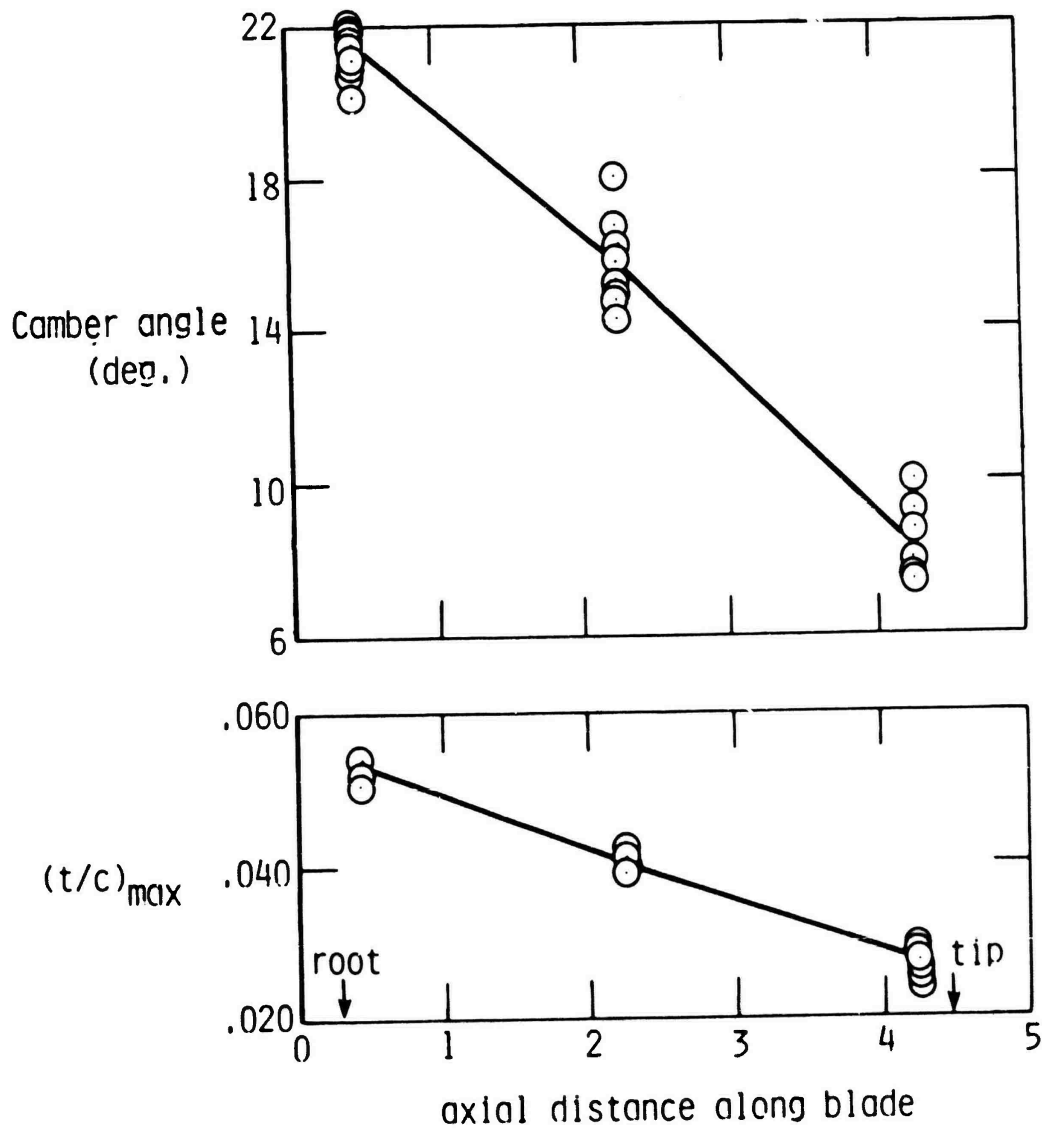

Figure 4.- Camber angle and thickness distributions for new third-stage rotor blades



✂ 0.002 in.

▣ NEW BLADES
--- USED BLADE

Figure 5.- Stage 3, tip section, new and used blades

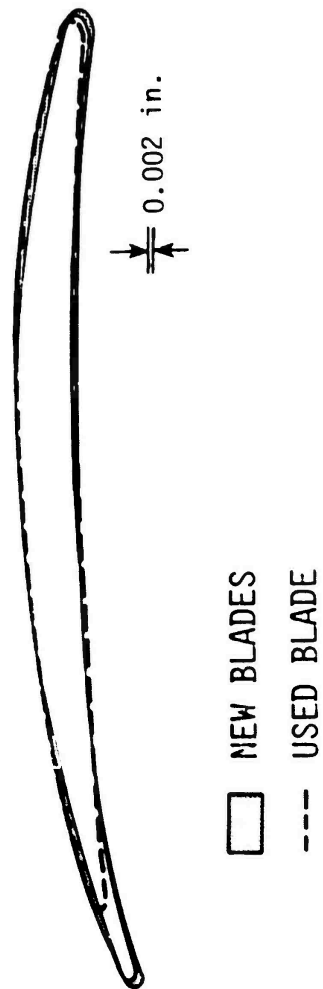

Figure 6.- Stage 13, tip section, new and used blades

AIRCRAFT TOWING FEASIBILITY STUDY

By

Henry S. L. Fan
and
Dan G. Haney

Peat, Marwick, Mitchell & Co.
San Francisco, California

PRECEDING PAGE BLANK - NOT FILMED

INTRODUCTION

The towing of aircraft has been a common practice at U.S. airports for many years, but it has been limited to towing short distances, such as during push-back from the passenger terminal, or to the towing of empty aircraft between the gate area of the terminal and an airline maintenance facility. Extended towing of loaded aircraft between the terminal and the runways has not been conducted.

Ever since the oil crisis of 1973-1974, however, the possibility of extended aircraft towing has been a subject of increasing interest--and controversy. As the costs of jet fuel have continued to spiral upward, many people in the aviation industry have expressed interest in obtaining information on the degree to which extended towing of aircraft on the airfield could reduce fuel consumption. At the same time, they have expressed concerns about towing-related questions of safety, aircraft operating economics, and airline marketing.

To help resolve some of these questions, the U.S. Department of Energy, on July 31, 1979, authorized Peat, Marwick, Mitchell & Co. to perform a study of the feasibility and constraints of towing aircraft between runways and terminal gate areas as a fuel conservation measure. The study was concentrated on towing operations at U.S. airports by major airlines--those that operate jet aircraft.

A report on the first phase of the study was issued in September 1980 (Ref. 1).

Specific objectives of the study were to:

- Identify safety concerns. The intent here was to document concerns regarding aircraft safety in towing operations, such as the structural integrity of the aircraft when subjected to frequent towing and the way in which communications would be handled between the tow tractor driver, the pilot, and the air traffic controller. (The Federal Aviation Administration was investigation the safety question in two other separate studies.)
- Review the state-of-the art in towing equipment. Both existing towing equipment in service today and proposed or potential new equipment that might be built to serve extended towing functions in the future were reviewed.
- Assess the operational effects of towing. This analysis dealt with the effects of potential airfield congestion that could result from extended aircraft towing operations.

SAFETY CONCERNS

As indicated above, the principal concerns regarding safety are the effects of towing on the structural integrity of the aircraft nose gear, and communication between the tow tractor driver, the pilot, and the air traffic controller.

Many people have expressed doubts about the ability of aircraft nose gear to withstand the stress and strain of extended towing. Failure of the nose gear structure would have grave consequences, especially during the takeoff and landing phases of an aircraft operation.

Communication between the tow tractor driver, pilot, and air traffic controller deals essentially with the question of "Who's in charge?" Should the aircraft captain be in charge of the movement of the aircraft when the aircraft is under tow, giving direction by either radio or wire to the tractor driver? Or should the tractor driver take directions from the air traffic controller and move the aircraft, with the pilot having only an advisory role? It is recognized that the tractor driver and the aircraft pilot deal with potential problems from different vantage points. People in the aviation industry have different opinions about how the communication should be handled and who should be in charge of the towing operations.

Recognizing the possibility that aircraft fatigue problems might result from extended aircraft towing (such as that proposed by the Massachusetts Port Authority for Boston-Logan International Airport), the Federal Aviation Administration contracted with Douglas Aircraft Company and Lockheed-California Company to study the matter.

The studies involved actual field testing and measuring the stress of towing on the nose gear structure. Lockheed used the L-1011 aircraft in its study, and Douglas used the DC-9 aircraft. Towing was performed at speeds up to 12 miles per hour for the L-1011 aircraft and up to 15 knots for the DC-9 aircraft.

MAJOR FINDINGS OF NOSE-GEAR STUDIES

The conclusions of the Lockheed study (Ref. 2) were as follows:

1. The proposed extended towing at Boston-Logan International Airport would not reduce the fatigue life of the L-1011 nose gear and supporting structure below the design value.
2. Dynamic towing loads are very sensitive to tractor driver technique. Peak dynamic loads (three times as large as typical dynamic loads) were observed during the testing. These measured loads were considered to be typical of those handled by experienced tractor drivers. Deviations from accepted towing procedures can result in dynamic loads of sufficient magnitude to reduce the fatigue life of the nose gear.
3. Dynamic towing loads are also sensitive to the transmission characteristics of tow vehicles, particularly during gear shifting.
4. No unusually high towing loads were measured during testing at Dorval Airport (Montreal) on taxiways covered with snow and ice. No difficulties were encountered in controlling the combined tractor and aircraft under these conditions.

5. Dynamic towing loads large enough to be significant from a fatigue damage viewpoint normally occur at the start and stop of a towing operation. The only exceptions are occasional large dynamic loads during tractor gear shifts.

The conclusions of the Douglas study (Ref. 3) were as follows:

1. The only significant loads encountered during towing were those associated with the start and stop portions of the maneuvers.
2. Loads due to runway/taxiway cross slopes and intersections, turning and steady-state towing, and wet and rough surfaces were not found to be significant.
3. Several nose landing gear components of the DC-9 could be affected by extended towing, especially on aircraft that have already accumulated a large number of flights.
4. The safety of the DC-9 nose landing gear subjected to extended towing can be ensured through periodic inspection of parts to detect fatigue damage, and the removal and replacement of parts as their life limits are reached.
5. Loads applied to the nose gear could also be reduced by having a shock-absorbing device built into existing tow bars. No such tow bars currently exist for the DC-9, and the design, production, and testing of one could take several months.

On the basis of the conclusions reached in the Lockheed and Douglas studies, it appears that, from an engineering point of view, towing would not degrade the safety of the nose gear structure of aircraft.

The Lockheed report indicated that towing loads were well within the safe range of design loads of the nose gear of L-1011 aircraft. The Douglas report concluded that certain nose gear components could be affected. However, safety could be ensured through more frequent inspection and, if necessary, replacement of those components.

REVIEW OF THE STATE-OF-THE-ART IN TOWING EQUIPMENT

Two categories of towing equipment were reviewed: (1) tow tractors that are currently available and commonly used for push-back and ferrying operations at most airports, and (2) tow tractors that are in the testing or proposal stage.

Currently Available Towing Equipment

Currently available tow tractors are not designed for extended towing of fully loaded aircraft or for high speeds. They are used mostly for push-back operations and for ferrying unloaded aircraft between the airline maintenance area and the passenger terminal gate area.

The push-back operation starts at the gate prior to aircraft departure. Two ground personnel are normally involved in connecting the aircraft to the tractor. One connects and disconnects the tow bar and communicates with the pilot; the other drives the tractor. The driver normally receives directions from the other member of the ground crew, who walks alongside the tractor, making sure that the aircraft wingtips clear adjacent obstacles.

The time from the start of push-back to the movement of the aircraft under its own power varies greatly by aircraft type and push-back distance. Normally, one aircraft engine is started during push-back; the remaining engines are started while the aircraft is taxiing out to the runway.

The tow tractors currently used in the United States are designed to handle various types of aircraft. These tractors operate at relatively low speeds (8-12 miles per hour); consequently, on-airfield travel times for towed aircraft would be increased substantially, compared with those for aircraft taxiing under their own power.

Proposed Towing Equipment

Tow tractor manufacturers have proposed new tractor designs to overcome problems associated with currently available tractors. Most of these new designs are based on the concept of lifting aircraft nose gear onto the tractor itself to reduce tractor size and to eliminate the need for tow bars. The new designs also permit high-speed towing.

One tractor, manufactured by a French company, is currently being used by Air France to ferry aircraft at Roissy-Charles De Gaulle Airport in Paris. It is powered by a 1,200-horsepower engine and would operate as follows.

The tractor driver moves the tractor back toward the aircraft, lowers the ramp at the back of the tractor, and pushes it under the tires of the nose gear. The ramp exerts a vertical thrust lifting the nose gear wheel off the ground and up the ramp toward the turntable. After the nose wheel is properly located, the tractor driver activates a remote-control locking device to keep the nose wheel in place.

The force applied to the hydraulically controlled lock depends on the preset power range which corresponds to the type and weight of aircraft to be towed. If the force exerted by the aircraft on the locking device exceeds this preset value, the locking device opens immediately, lowering the ramp at the same time, and the aircraft is released at once. This design allows the pilot to disengage the aircraft from the tractor in an emergency by applying the aircraft brakes during towing. The hydraulic transmission on the tractor also keeps the aircraft from jerking while being towed. The maximum speed while towing loaded aircraft is expected to be between 30 and 35 miles per hour.

Effects of Towing on Airfield Operations

The effects of aircraft towing on airfield operations were analyzed by using models and techniques developed by Peat, Marwick, Mitchell & Co. for the FAA. Estimates were made of delays related to the slower speed of the tow tractor and the possible congestion caused by aircraft under tow, aircraft not under tow, and circulation of tow tractors on the airfield. These delay estimates were then used to estimate fuel and cost savings from aircraft towing operations.

The analysis of airfield operations (using 1978 statistics of airport activity) was conducted for the top 20 airports in the United States. These airports, listed below, accounted for about 50% of the total air carrier operations and about 60% of the total enplaned passengers in the United States in recent years.

William B. Hartsfield Atlanta International Airport
Boston-Logan International Airport
Chicago-O'Hare International Airport
Dallas/Fort Worth Airport
Denver Stapleton International Airport

Honolulu International Airport
Houston Intercontinental Airport
John F. Kennedy International Airport
LaGuardia Airport
Los Angeles International Airport

Miami International Airport
Minneapolis-St. Paul International Airport
New Orleans International Airport
Philadelphia International Airport
Greater Pittsburgh International Airport

Lambert-St. Louis International Airport
San Francisco International Airport
Seattle-Tacoma International Airport
Tampa International Airport
Washington National Airport

The actual effects of extended aircraft towing on airfield operations at any airport would of course depend on the specific characteristics of that airport, including the physical layout of the passenger terminal and gate area, runways, taxiways, and roadways; ground movement patterns; runway use; the types and number of aircraft using the airport; and congestion levels. These characteristics and their operational implications at the 20 study airports were analyzed in the study.

In addition, two assumptions were made in assessing the operational effects. First, it was assumed that if an airport has runways that are laterally separated by less than 1,000 feet, aircraft arriving or departing on these runways would be allowed to taxi (rather than be towed) across an active runway. Aircraft would be towed only between the passenger terminal/gate area and the point where aircraft taxiing starts (for departing aircraft) or stops (for arriving aircraft).

Second, it was assumed that roadways for the return of tractors to their stations (after completing a towing operation) could be constructed, if necessary, to provide separate paths for tractors towing aircraft and tractors not towing aircraft. The costs of such construction were included in the benefit-cost analysis.

The results of this analysis showed that there would be some operational difficulties with aircraft towing at the 20 study airports, but these could be reduced by constructing tractor roadways and staging areas, limiting the number of aircraft towed, and developing better towing equipment (as is now being proposed by tractor manufacturers).

Several other concerns were identified relating to extra air traffic controller workload, disruption of airline schedules, and passenger comfort were identified. The severity of these concerns is difficult to determine in an analytical study. The problems involved should be studied in more detail; perhaps some of them could be resolved during an actual field test of aircraft towing.

FUEL AND COST SAVINGS AT 20 AIRPORTS

The operational analysis was conducted for the conventional tractor and for a possible high-speed tractor. Fuel savings achievable through aircraft towing were determined by subtracting increases in tow tractor and auxiliary power unit fuel consumption from reductions in aircraft engine fuel consumption.

Additional costs associated with aircraft towing were also estimated. These costs included: annualized capital costs for additional equipment required; increases in annual direct operating costs such as those for tractor engine maintenance, ground crew, and flight crew; and annualized construction costs for tractor roadways and staging areas, if required.

These costs were then compared with savings resulting from reductions in fuel costs (assumed to be \$1.00 per gallon) to arrive at net costs or savings. The estimated potential annual fuel and cost savings resulting from aircraft towing are presented in Tables 1 and 2, respectively.

With the conventional tractor, about 178 million gallons of aircraft jet fuel would be saved annually from towing operations. Cost savings would amount to about \$64 million, assuming 1978 levels of operation.

With a new high-speed tractor, the estimated fuel savings would be about 165 million gallons annually, and the cost saving would be about \$80 million.

The new high-speed tractor would save less fuel primarily because the new tractor itself would consume more fuel than the conventional tractors. However, the dollar savings would be greater for the new high-speed tractor because the higher speed would reduce travel time, and hence crew costs, during the towing operations.

Table 1

ESTIMATED POTENTIAL ANNUAL FUEL SAVINGS
FROM EXTENDED AIRCRAFT TOWING
(Millions of Gallons)

<u>Airport</u>	<u>Currently available tow tractors</u>	<u>Proposed tow tractors</u>
Atlanta	14.29	13.84
Boston	6.75	6.03
Chicago O'Hare	39.12	35.76
Dallas/Fort Worth	10.41	10.30
Denver	8.20	7.45
Honolulu	2.42	2.53
Houston	3.76	3.43
Kennedy (New York)	22.63	21.76
LaGuardia (New York)	10.04	8.91
Los Angeles	16.52	15.59
Miami	7.71	7.35
Minneapolis-St. Paul	2.99	2.62
New Orleans	1.46	1.26
Philadelphia	3.77	3.33
Pittsburgh	2.64	2.30
St. Louis	5.07	4.39
San Francisco	9.83	9.20
Seattle-Tacoma	2.50	2.35
Tampa	3.68	3.35
Washington, D.C. (National)	<u>4.02</u>	<u>3.49</u>
Total	177.81	165.23

Note: The estimates shown are based on 1978 levels of aircraft operations.

Source: Peat, Marwick, Mitchell & Co.

Table 2

SUMMARY OF NET ANNUAL SAVINGS (COSTS) ASSOCIATED WITH
CURRENTLY AVAILABLE AND PROPOSED AIRCRAFT TOWING EQUIPMENT
(Millions of Dollars)

<u>Airport</u>	<u>Currently available towing equipment</u>	<u>Proposed towing equipment</u>
Atlanta	\$ 3.5	\$ 4.8
Boston	2.6	2.2
Chicago O'Hare	23.8	19.5
Dallas/Fort Worth	(2.4)	4.6
Denver	3.1	2.7
Honolulu	0.3	1.4
Houston	0.1	1.1
Kennedy (New York)	10.2	14.2
LaGuardia (New York)	5.2	3.9
Los Angeles	7.8	9.6
Miami	0.2	3.7
Minneapolis-St. Paul	0.9	1.1
New Orleans	0.3	0.4
Philadelphia	1.7	1.3
Pittsburgh	(1.1)	(0.3)
St. Louis	1.3	1.3
San Francisco	3.8	5.3
Seattle-Tacoma	0.6	1.1
Tampa	0.9	1.1
Washington, D.C.	1.6	1.0
(National)	—	—
Total	64.4	80.0

Note: Numbers in parentheses indicate net costs.

Source: Peat, Marwick, Mitchell & Co.

UNRESOLVED ISSUES

A number of unresolved issues remain as a result of the study to date.

Although useful information is now available on the DC-9 and L-1011 aircraft, no information is available on any of the aircraft manufactured by Boeing. Since Boeing aircraft are in widespread use in the United States, studies of possible nose gear problems with these aircraft should also be made.

Radio communication questions still need to be resolved. The airlines have various opinions on how such communication would be carried out. In addition, the FAA needs to comment on this issue.

Flight check procedures are another unresolved issue. The airlines now use different procedures for flight checkout of aircraft prior to departure. Many checks are made after the aircraft engines are started. As a result, some time would be required for checkout after the towing operation is complete and engines are started. The airlines have suggested that checkout procedures might be modified so that more of them could be made when the aircraft is under power from the auxiliary power unit, rather than from the main engines. Possibly, aircraft simulator exercises could help determine how much time would be required for checkout of aircraft under a towing program.

Congestion caused by slow tractors is a matter of concern to the airlines because they want to minimize any increase in block time that would result from aircraft towing. Although it has been assumed that unloaded tow tractors would use separate roadways for their return trip, the airfield geometry at some airport could still result in congestion of tow tractors and aircraft.

A number of legal/jurisdictional issues remain unresolved. One of these is the aircraft communications issue described above. Another is the question of ownership of the tow tractors. It has been suggested that tow tractors could be used more efficiently if the airport operator were to own all of the tow tractors used at the airport. However, the question of legal responsibility in the event of an accident would have to be carefully resolved.

Potential problems with labor unions also need to be considered. Unions for mechanics, pilots, and air traffic controllers, among others, might be affected by aircraft towing.

PROJECT STATUS AND FURTHER STEPS

As of this date, staff members of the U.S. Department of Energy and Peat, Marwick, Mitchell & Co. have interviewed a number of airline officials and other parties. Although airline personnel have expressed some enthusiasm, the general feeling is one of skepticism about the potential overall desirability of extended towing at U.S. airports.

The Air Transport Association of America (ATA) conducted a survey of airlines, asking them to comment on the report prepared by Peat, Marwick, Mitchell & Co. in September 1980. The results of the survey confirmed the general skepticism about the desirability of towing. It appears that any substantial steps by the airlines toward evaluation of aircraft towing would have to be taken under the auspices of the ATA.

A design for a towing test will be prepared in the near future. This design will be structured to provide certain mechanical and operational data to help resolve most of the issues that remain. It will be made with fully loaded aircraft, but not with aircraft in revenue service.

After the test design is approved, the towing test would be conducted. Then the test findings would be reviewed, and further steps would be outlined.

If desirable, a full-scale demonstration of aircraft towing at one or more U.S. airports could be conducted to try to resolve remaining issues.

Air France, the operator of the high-speed tow tractor in Paris, has indicated a willingness to provide its tow tractor to demonstrate its operation in the United States. Whether this offer will be accepted and how any demonstration might be conducted will be decided by the government agencies involved.

REFERENCES

1. U.S. Department of Energy, "Aircraft Towing Feasibility Study," September 1980 (Peat, Marwick, Mitchell & Co. study).
2. Federal Aviation Administration, "Evaluation of the Impact of Towing the L-1011 Airplane at Boston-Logan Airport," May 1980 (Lockheed study).
3. Federal Aviation Administration, "Evaluation of the Impact of Towing DC-9 Transport Airplanes at Boston-Logan Airport," May 1980 (Douglas study).

THE ANALYSIS OF INTEGRATED FUEL
EFFICIENT, LOW NOISE PROCEDURES
IN LAX TERMINAL AREA OPERATIONS

Prepared By

John B. McKinley
Systems Control, Inc. (Vt.)
Champlain Technology Industries Division
West Palm Beach, Florida 33406

and

Robert L. Bowles
Transportation Economist
Federal Aviation Administration
Washington, D.C. 20545

ACKNOWLEDGEMENTS

Sincere thanks is extended to the Office of Transportation Programs, Conservation and Solar Energy, U.S. Department of Energy for extending the invitation to present this paper and also for sponsoring the program for which this paper is a summary.

Special thanks is also extended to the Office of Environment and Energy of the Federal Aviation Administration for providing the use of their aircraft fuel burn computer model "LINKMOD", and also for the assistance in using the Integrated Noise Model (INM), Version 2.7.

ABSTRACT

This paper addresses specific aviation energy conservation issues considered significant by the U.S. Department of Energy. In particular, terminal area fuel conservation and airport noise level relationships are investigated. The first objective was to quantify the potential fuel savings and noise level reduction in the Los Angeles International (LAX) terminal area between 1980 and 1990 attributable to compliance with the noise requirements of FAR Part 36. These savings will be due to the retiring, retrofiting and re-engining of older narrow-body aircraft (DC-8, B707, etc.) and the growth of wide body aircraft operations (DC-10, B747, B767, etc.). The second objective was to determine what current noise abatement procedures could be relaxed without adversely impacting current (1980) noise levels, and at the same time conserving additional fuel.

To accomplish these objectives, two FAA computer models were used. The Integrated Noise Model (INM) Version 2.7 (Reference 4), was used for noise analysis, and LINKMOD (Reference 5), a preliminary fuel burn model, for the fuel analysis. The results of this detailed analysis revealed that due to the changing aircraft mix at LAX to include more wide body aircraft and fewer narrow body aircraft operations, airport noise level will decrease slightly, but significantly for 1985 and 1990, respectively, from the 1980 baseline. In addition, there is demonstrated a 4.5 million gallon fuel savings yearly in 1985, and 5.0 million gallons yearly in 1990.

Unconstrained terminal procedures analysis exhibited an unacceptable increase in airport noise level between 1980 and 1985. However, this increase occurs over water on departure, where the largest noise absorption takes place. Approach noise showed no change with unconstrained procedures. Annual fuel savings due to unconstrained procedures proved to be substantial. For 1985, a fuel savings of 29.8 million gallons yearly was demonstrated, in addition to the 4.5 million gallons due to wide body traffic mix changes. In 1990, annual fuel savings are 31.0 million gallons due to unconstrained procedures at the LAX terminal area. The largest percent of this savings was realized in the approach flight phase where current noise levels were maintained.

INTRODUCTION

This paper represents a summary of a study sponsored by the Office of Transportation Programs, Conservation and Solar Energy of the U.S. Department of Energy (DOE). The study comprised an eight month program to identify the relationship between terminal area fuel consumption and airport noise level, and concluded with a final report (Reference 1). Included in this paper are the results of that study as they apply to Los Angeles International Airport.

BACKGROUND

The Federal Aviation Administration (FAA), National Aeronautics and Space Administration (NASA) and Industry have been working for many years on alternate techniques for reducing aircraft noise. This research has spanned the gamut of operational procedures from high speed reduced drag approaches to reduced power settings on take-off. This research has also included a thorough investigation into the causes of noise, be it aerodynamic or propulsion system generated. Simultaneously but independently, these same agencies plus the Department of Energy have been conducting in-depth research into alternative means of reducing fuel consumption in the air transportation industry. In particular, FAA and DOE studies have examined climb, cruise and descent procedures which can be employed to reduce fuel consumption. NASA and industry have been investigating advanced hardware/software design techniques (airframe, power plant, avionics, etc.) which could significantly decrease fuel consumption. In addition, two recent DOE studies have determined that current noise abatement procedures at specific airports contribute a significant amount to fuel inefficiency (Reference 6,7). Nowhere in the literature has there been any effort to relate the dependency of fuel consumption on the noise abatement procedures being flown or the relative noise impact of various fuel conservative flight procedures on a terminal area scale, or a national scale.

OBJECTIVES AND PURPOSE

The primary objective of this investigation then, was to identify potential fuel consumption benefits incurred by commercial jet aircraft due to removing or revising terminal area noise abatement procedures between 1980 and 1990. A secondary objective was to determine the impact of changing aircraft mix at these terminal areas for 1985 and 1990, and consider both noise reduction and fuel consumption reduction achievable due to quieter, more fuel efficient aircraft types, such as the L1011, DC-10, A300, A310, B757, and B767.

These objectives were concerned with the purpose to analytically demonstrate the potential benefits of reduced fuel consumption and lower airport noise levels due to retiring and re-engining older aircraft, and the growth of wide body aircraft operations through 1990. Such improvements in noise level and fuel consumption could conceivably reduce FAA, EPA, and local community opposition to removing or revising current noise abatement procedures to provide further fuel conservation without increasing noise levels above a 1980 base line.

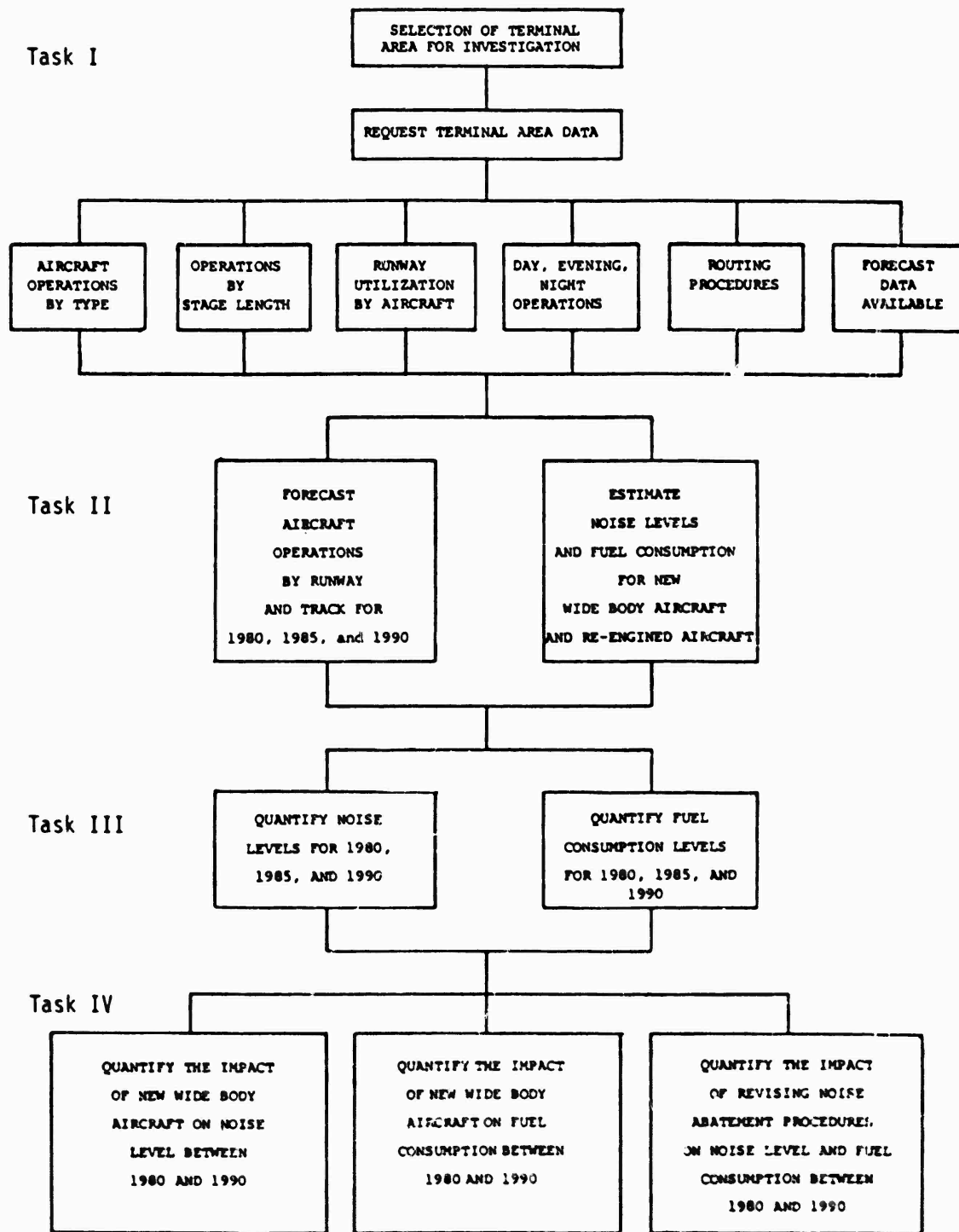

Figure 1 Flow Diagram Detailing Program Tasks and Objectives

METHOD OF APPROACH

Two general terms are used throughout this paper referring to terminal area operational procedures. The first is "constrained" operations, referring to procedures having a potential to restrict or restrain improved fuel efficient aircraft operations within the terminal area. The constrained operations investigated in this study are:

- Noise Abatement Routings (2D)
- Arrival and Departure Speed and/or Altitude Constraints Below 10,000 feet Mean Sea Level (MSL)
- Runway Use Program

The second term is "unconstrained" operations which, in the context of this study, refers to those constrained procedures which are revised or replaced to include the potentially more fuel efficient procedures below:

- Direct Terminal Routing
- Optimum Speed For Each Aircraft Type
- Continuous 3° Descents and Delayed Flap Approach Procedures

Four tasks were performed to comply with the objectives. These tasks, described below are also shown in the flow diagram of Figure 1.

During Task I, eight terminal areas were identified and selected for study based on a combination of such factors as population exposure to noise, wide body aircraft operations and narrow body aircraft operations. These parameters are available in the Airport Information File (AIF) (Reference 2). Among the airports listed below in Table 1, Los Angeles International was selected for the initial investigation.

Table 1 Terminal Areas Selected for This Study

TERMINAL AREA	IDENTIFIER
Los Angeles International	LAX
San Francisco International	SFO
John F. Kennedy International	JFK
Chicago/O'Hare International	ORD
Washington National	DCA
Atlanta International	ATL
Logan International	BOS
Denver International	DEN

Also during Task I, detailed terminal area aircraft operations statistics and forecast data was requested and gathered from each airport in Table 1, as well as from the Federal Aviation Administration (FAA). The detail of the requests included such items as: number and type of commercial aircraft operation, number of operations by stage length, and runway utilization by aircraft type by day, evening and night operations. Unfortunately, most of this data is not readily available, particularly the forecast data of this detail.

During Task II, when the data collected for LAX was being compiled, it was discovered necessary to prepare 1985 and 1990 forecast data of retired and replacement aircraft for operations by runway, time of day, etc. This was accomplished with assistance from the FAA's noise compliance fleet projection of domestic commercial jet aircraft (Reference: 3).

It was also necessary during Task II to estimate noise level values for the new wide body and FAR 36 noise compliant re-engined aircraft of 1985 and 1990. (In the context of the study, re-engined aircraft also referred to aircraft fitted with noise absorption material.) Fuel flow estimates were generated for the new wide body aircraft based on the Airbus 300.

The major effort in Task III involved the assimilation of the data for LAX to be processed by two FAA computer models. For the airport noise analysis, the FAA Integrated Noise Model (INM), Version 2.7 (Reference 4), was used to analyze 1980, 1985 and 1990 noise levels for constrained and unconstrained procedures. This model was released by the FAA, Office of Aviation Environment and Energy (AEE). Version 2.7, released in September 1979, contains enhancements, corrections, and a larger data base of aircraft noise and performance than Version 1, released in January 1978. The purpose of these models is to help airport planners in assessing the noise impact of aircraft at an airport, or further, to calculate and integrate the noise impact of an entire day's operation. Version 2.7 was chosen for this investigation because it allows the user to define alternative sets of aircraft noise and performance data to more closely simulate airport characteristics.

The INM is capable of defining airport noise impact in terms of contours of equal exposure for any of the four cumulative energy measures below:

- Noise Exposure Forecast (NEF)
- Equivalent Sound Level (Leq)
- Day-Night Average Sound Level (Ldn)
- Community Noise Equivalent Level (CNEL)

For this study Ldn was used to be consistent with other current studies.

The aircraft fuel analysis model used was provided by the FAA, AEE on a trial basis, since the model was not ready for public use. The version of the model used is called LINKTST, an enhanced version of "LINKMOD" (Reference 5). Presently, LINKMOD provides fuel burn estimates for only individual aircraft along a user defined flight profile. This

model is capable of determining fuel burns over a complete flight profile for multiple segments linked together. This may be for takeoff, approach, cruise, or any combination.

Standard weight-classified profiles provided in the INM data base were used to define approach and takeoff profiles for each aircraft. Approach and departure procedures were defined for both computer models and for both the constrained and unconstrained procedures where they differed. This was true for the continuous 3° glide slope and delayed flap approach, as well as for the optimum speed departure profiles.

The data base of both models contain commercial jet aircraft, however, the INM is more extensive. It was, therefore, necessary to define what aircraft for the noise analysis would represent the fewer aircraft of LINKMOD. This is shown in Table 2, based on aircraft type categories. Also shown in Table 2 are the new wide body aircraft not found in either data base. In this case the A300 was redefined appropriately for both models to represent the new A310, B757 and B767 aircraft.

Table 2 Aircraft Within the INM and the LINKMOD Fuel Model Data Bases

LINKMOD AIRCRAFT	TYPE	INM AIRCRAFT	REDEFINED TO REPRESENT
DC-9	2 Engine Narrow Body	DC-9-32 DC-9-15 737-100/200	
A300B2	2 Engine Wide Body	A300	A310 B757 B767
B727	3 Engine Narrow Body	727-200 727-100	
L1011	3 Engine Wide Body	L1011 DC-10-10	
B707	4 Engine Narrow Body	707-320 B/C 707-120B 720B DC-8-55 DC-8-61/63	
B747	4 Engine Wide Body	747-200	

These aircraft were analyzed by both models over the tracks shown in Figure 2. These tracks are representative of typical instrument, visual and noise abatement procedures currently in use at LAX. These tracks were used for the constrained procedures analysis for 1980, 1985 and 1990. For each track the number and type of aircraft operation was defined. This approach made it possible to determine the influence of the changing aircraft mix on airport noise levels and fuel consumption for each time period.

Shown in Figure 3 is a comparison of the constrained and unconstrained flight tracks for LAX. The circled numbers of this figure (1985 example) show the number of daily aircraft operations by various aircraft types. It also describes the more direct (unconstrained) tracks used in the 1985 and 1990 analyses.

As an output of Task III, LAX airport noise levels for three Ldn values were quantified for an average day in 1980, 1985 and 1990 for constrained operations, and for 1985 and 1990 for unconstrained operations. Daily fuel consumption was also quantified for the same time periods.

The objective of Task IV was to interpret the results of Task III. More specifically, this was twofold. First, to quantify the potential impact of the changing aircraft mix on fuel and noise between 1980 and 1990 for constrained procedures. The second objective was to quantify the potential impact of revising terminal area procedures on fuel and noise between 1980 and 1990.

RESULTS AND CONCLUSIONS

The organization of the results discussed below is according to the basic study objectives and issues which were considered significant by the Department of Energy. These issues are:

- 1) Is there a potential fuel savings inherently introduced due to the retiring and re-engining of older aircraft and the growth of wide body aircraft operations caused by the noise reduction requirements of FAR Part 36?
- 2) What is the relationship between the noise impact of this changing fleet mix and the magnitude of the potential fuel savings in the current ATC environment?
- 3) Can the current ATC noise abatement procedures, speed restrictions, etc. be relaxed due to the predominance of "quieter" aircraft in the 1985 to 1990 time period?
- 4) What additional fuel savings can be achieved in the relaxed or unconstrained ATC environment?

Each of these questions has been treated in depth in the final report (Reference 1) for both the overall fleet mix in the Los Angeles International terminal area and for individual aircraft types. The following summary discussion is provided to highlight quantitatively

TN MN

- - - - - Direction of Arrows Describe
Arrival or Departure Flow

-- -- Both Arrival and Departure Flow

15°E Variation

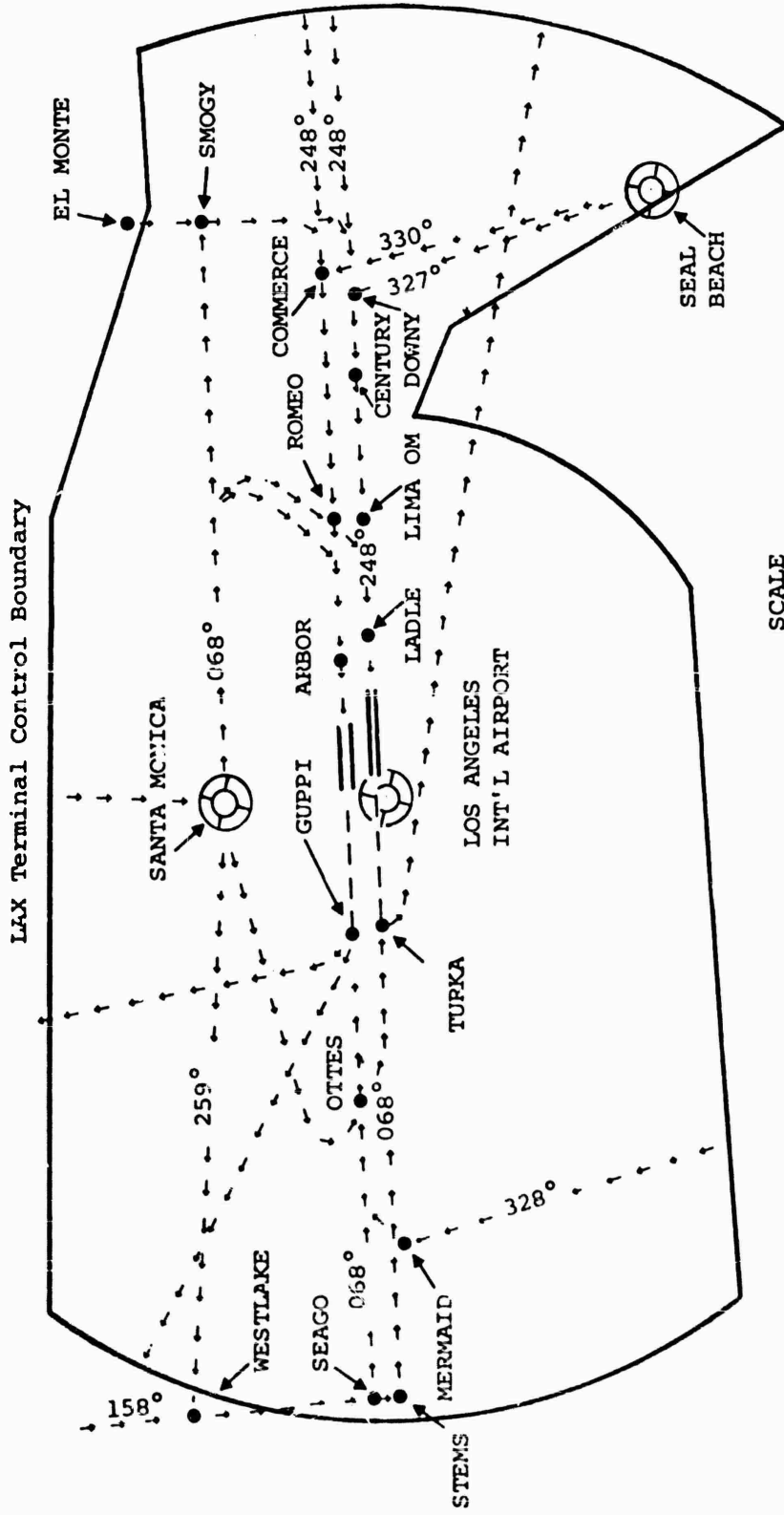

SCALE
5 NM

Figure 2 Los Angeles International Airport Case 1, Arrival and Departure Terminal Area Track Configuration

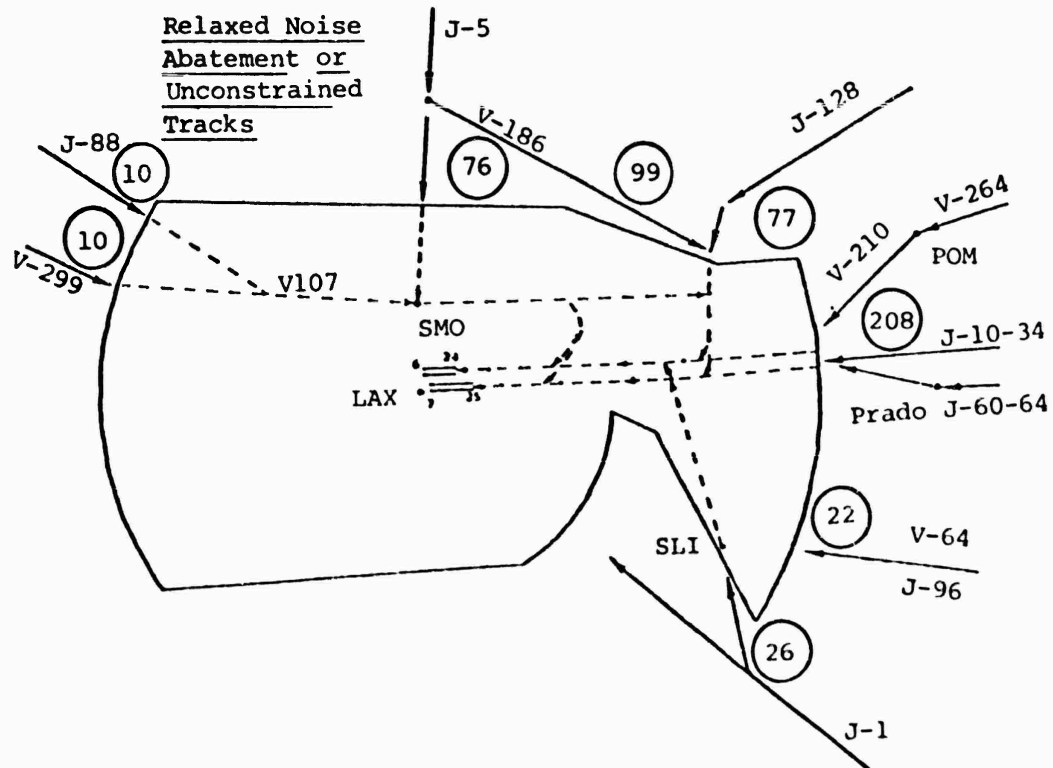
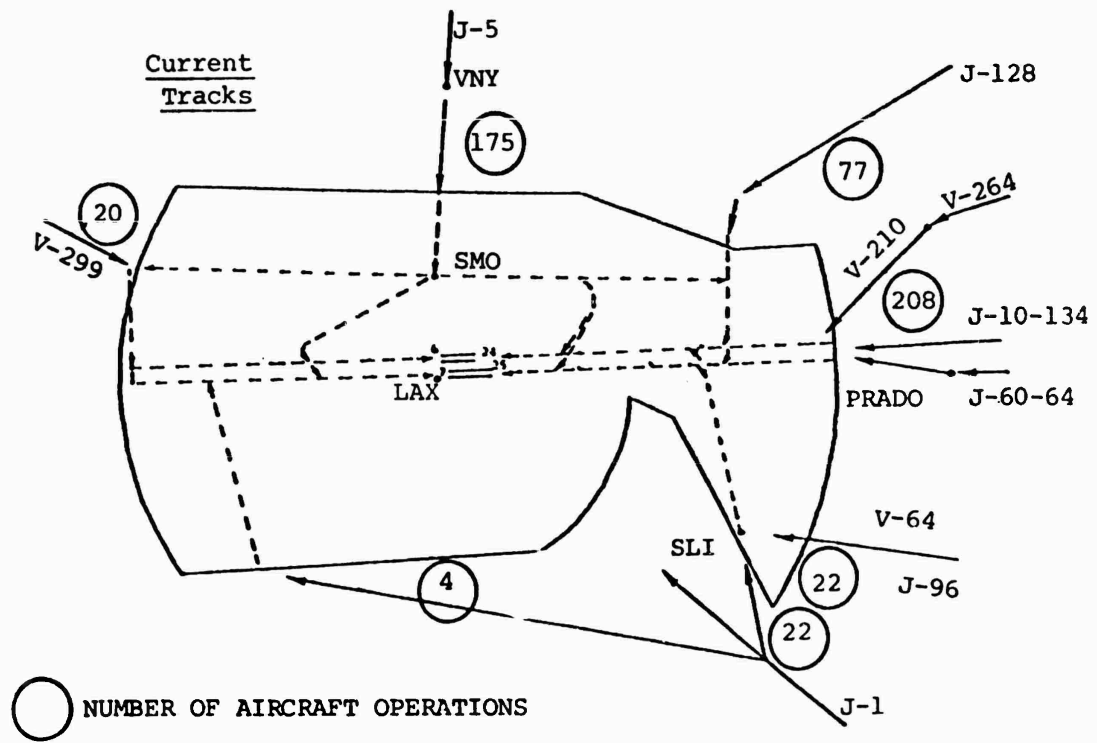

Figure 3 Contribution of Aircraft Operations for Current and Revised Tracks

the most significant results of this study.

In order to answer the four issues, a two-step process was required. First, the impact of fleet mix changes on both noise and fuel consumption was evaluated in today's LAX ATC environment.

This environment at Los Angeles International (LAX) includes the following constraints on aircraft arrival and departure profiles:

- Noise Abatement Routings (2D)
- Arrival and Departure Speed and/or Altitude Constraints Below 10,000 feet
- Runway Use Program

The operation of aircraft under these ground rules limits the pilot's ability to choose the most fuel efficient flight profiles and procedures. For this reason these procedures are referred to as "Constrained" operations. The operation of current and forecast air traffic at LAX under these constrained conditions were evaluated for three time periods — 1980, 1985 and 1990. Noise footprint results were generated by the Integrated Noise Model (INM) (Reference 4) developed by the FAA. These INM results were used to answer the first major issue. As seen in Figures 4 through 6, the INM results showed a small but significant reduction in noise footprint for each of the three levels investigated. Reductions in noise contour area of this magnitude mean that a significant reduction in community annoyance will occur during this time period. But, at what cost? These area reductions could be utilized to save considerable amounts of jet fuel if it can be considered acceptable to trade noise for fuel savings. If this is acceptable, the answer to issue number 1 is:

There is a large potential fuel savings inherent in the terminal area operations of the 1985 and 1990 time periods due to traffic mix changes.

In order to capitalize on this potential savings, community noise exposure (annoyance) must be maintained at the 1980 level and more fuel efficient arrival and departure procedures must be developed to optimize on the achievable savings.

Addressing issue number 2 required quantification of the basic fuel savings attributable to the re-engined narrow body and the new wide body aircraft under current constrained operating procedures. This was accomplished using a preliminary FAA generated fuel model "LINKMOD". This model determines fuel burned for a single aircraft over a complete departure or arrival profile. This model was run sequentially for each of the aircraft types operating in the LAX terminal to evaluate fuel consumption differences for each profile flown. The results of that evaluation showed that

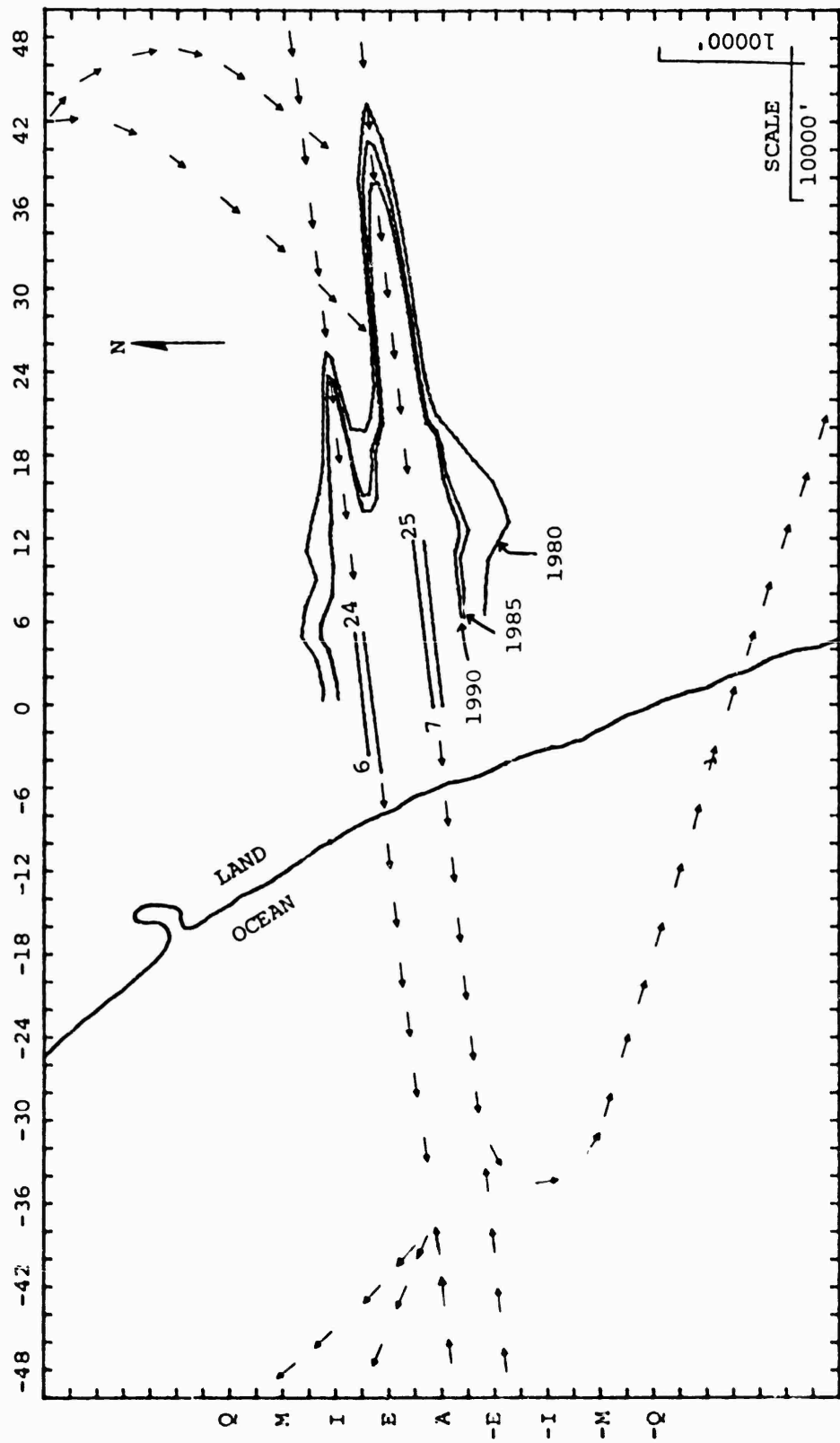

Figure 3.4 LAX 65Ldn Contour Comparison of Current ATC Procedures For 1980, 1985, and 1990

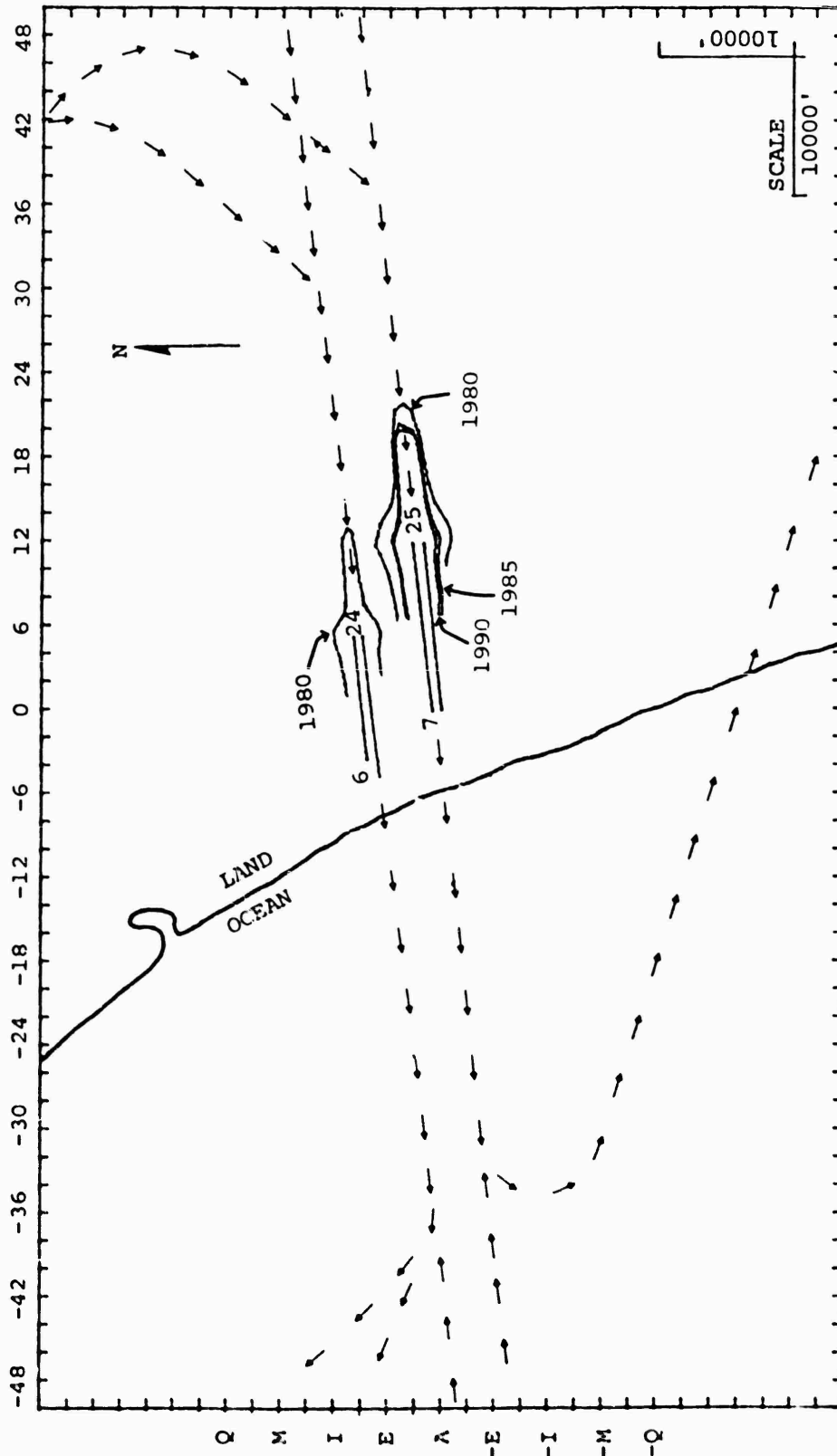

Figure 3.5 LAX 75 Ldn Contour Comparison of Current ATC Procedures For 1980, 1985, and 1990

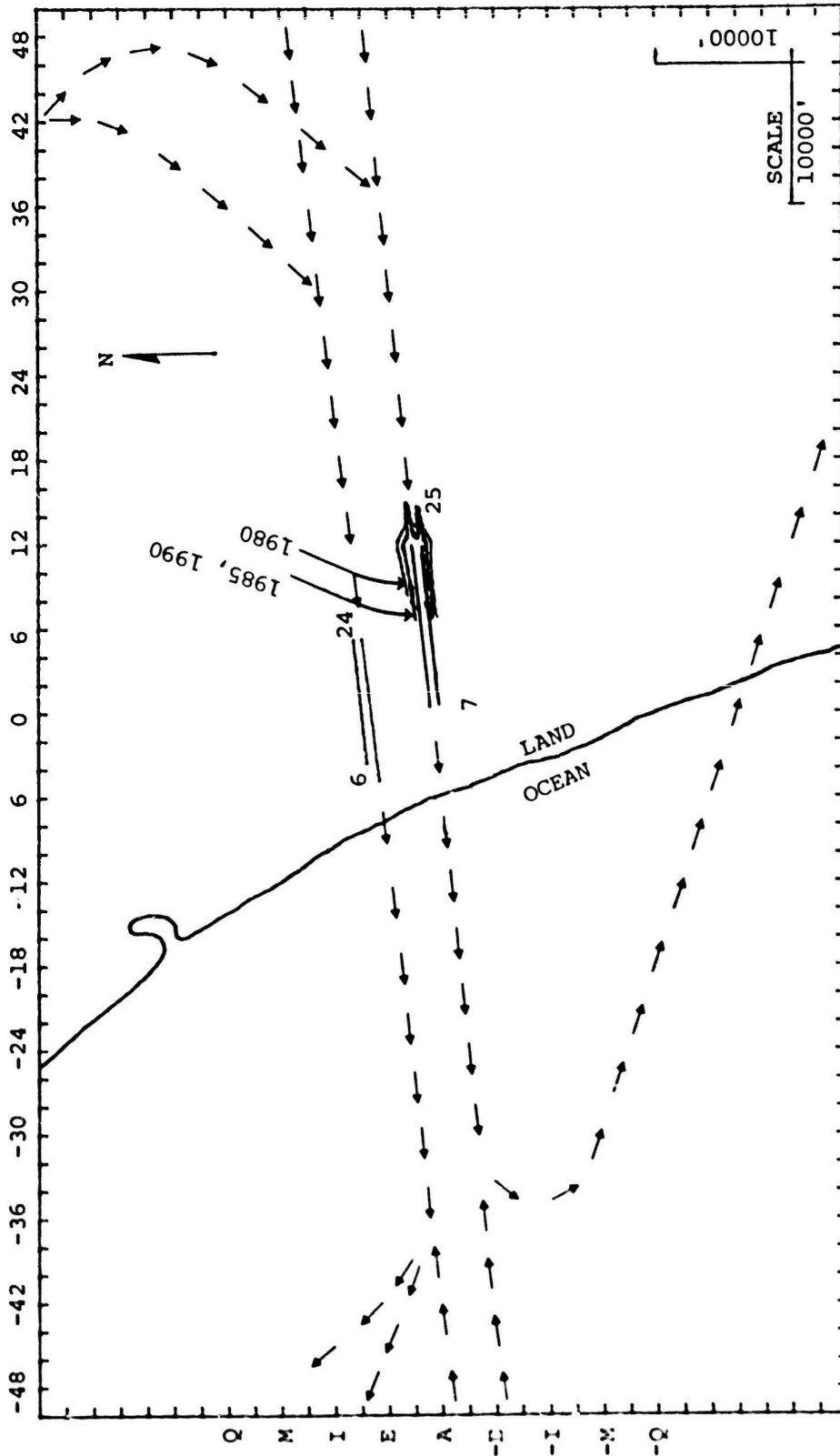

Figure 3.6 LAX 85Ldn Contour Comparison of Current ATC Procedures For 1980, 1985, and 1990

between 1980 and 1985 annual fuel consumption in the LAX terminal area would be reduced by 4.5 million gallons. Similarly, the introduction of more fuel efficient aircraft and changing fleet mix accounted for 5.0 million gallons annual reduction between 1980 and 1990. It can be seen that the largest improvement occurs in the first five year period.

The answer to issue number 2 then becomes:

There is a significant annual fuel savings benefit attributable solely to the change in fleet mix expected to occur during the study period. This fuel benefit complements the noise reduction achieved by the re-engined narrow body aircraft and the wide body aircraft which comply with FAR Part 36.

The next issue, number 3, asked the question — How can the current ATC procedures and routes be modified to capitalize even further on the inherent fuel efficiency of these new aircraft? The answer to this question can be approached in many ways. For the purposes of this study, four major flight profile restrictions were selected. These four were thought to offer the largest potential additional savings based on a review of several aircraft operating manuals, qualitative, operational experience and judgement. For the remainder of this analysis, unconstrained aircraft operations were defined as:

- Direct Terminal Routing (2D and 3D RNAV)
- Optimum Speed Climb for Each Aircraft Type
- Continuous 3° Descent Profiles and Delayed Flap Approach Procedures

Using these procedures and routing options, the INM and LINKMOD were re-run for the same traffic mixes and the same time periods previously used. The results summarized in Table 4 were a qualified success. That is, the new procedures showed that the annual fuel savings attributable to these unconstrained operations was 22.5 million gallons in 1985 compared to the constrained fuel consumption of these same years.

Table 4 Summary of Annual Fuel Savings in Gallons for Unconstrained LAX Terminal Area Procedures

	Daily Gallons		Annual Millions of Gallons	
	1985	1990	1985	1990
Revised TMA Approach Routes	1612	1634	.59	.60
Unrestricted 3° Glide Slope	60063	63056	21.94	23.03
Total Approach	61675	64690	22.53	23.63
Optimum Speed Departure	19905	20165	7.27	7.37
Total Unconstrained	81580	84855	29.80	30.99

These increased savings are in addition to the inherent 4.5 million gallons and 5.0 million gallons previously determined due to traffic mix alone. However, in order to achieve these large improvements, one of the basic ground rules had to be re-examined. This was due to the fact that the unconstrained departure procedures produced a significant increase in departure noise contour area. For this reason, the unconstrained departure procedures are considered unacceptable from an airport noise environment viewpoint. However, as seen in Figures 7 and 8, unconstrained approach procedures produced noise footprints not exceeding the 1980 baseline for community acceptability.

As a final check, the fuel savings attributable to revised approach procedures was compared to that attributable to the noisy revised departure procedures. This analysis showed that the largest fuel savings occurred, by far, due to the unconstrained approach procedures. Therefore, if only this portion of the analysis is used the potential annual fuel savings available in 1985 is 22.5 million gallons compared to 1985 constrained operations and in 1990, 23.6 million gallons compared to 1990 constrained operations.

The answers to the final two major issues therefore become:

Issue Number 3: The current ATC noise abatement procedures, route restrictions, etc., can be relaxed due to the quieter aircraft which will predominate in the 1985 and 1990 time periods. The specific relaxation alternatives investigated in this study showed significant fuel savings potential.

Issue Number 4: The additional fuel savings attributable to the relaxed or unconstrained ATC environment are on the order of 29.8 - 22.5 million gallons annually depending on whether or not both the approach and departure constraints are removed (29.8) or just the approach constraints are removed (22.5). In either case these potential savings are

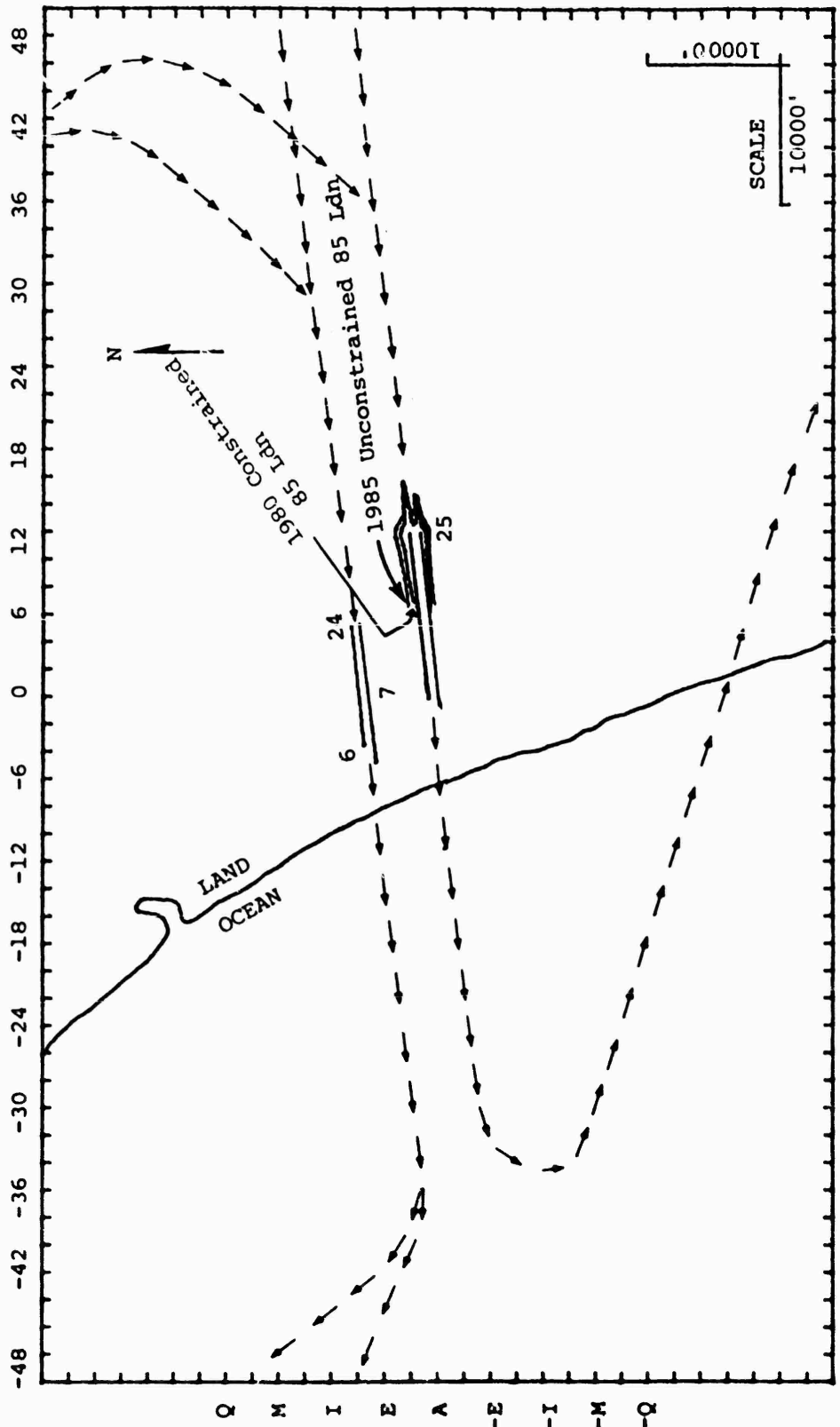

Figure 3.8 Los Angeles International Airport 85 Ldn
 Contour Plot Comparison of Constrained and
 Unconstrained Terminal Procedures

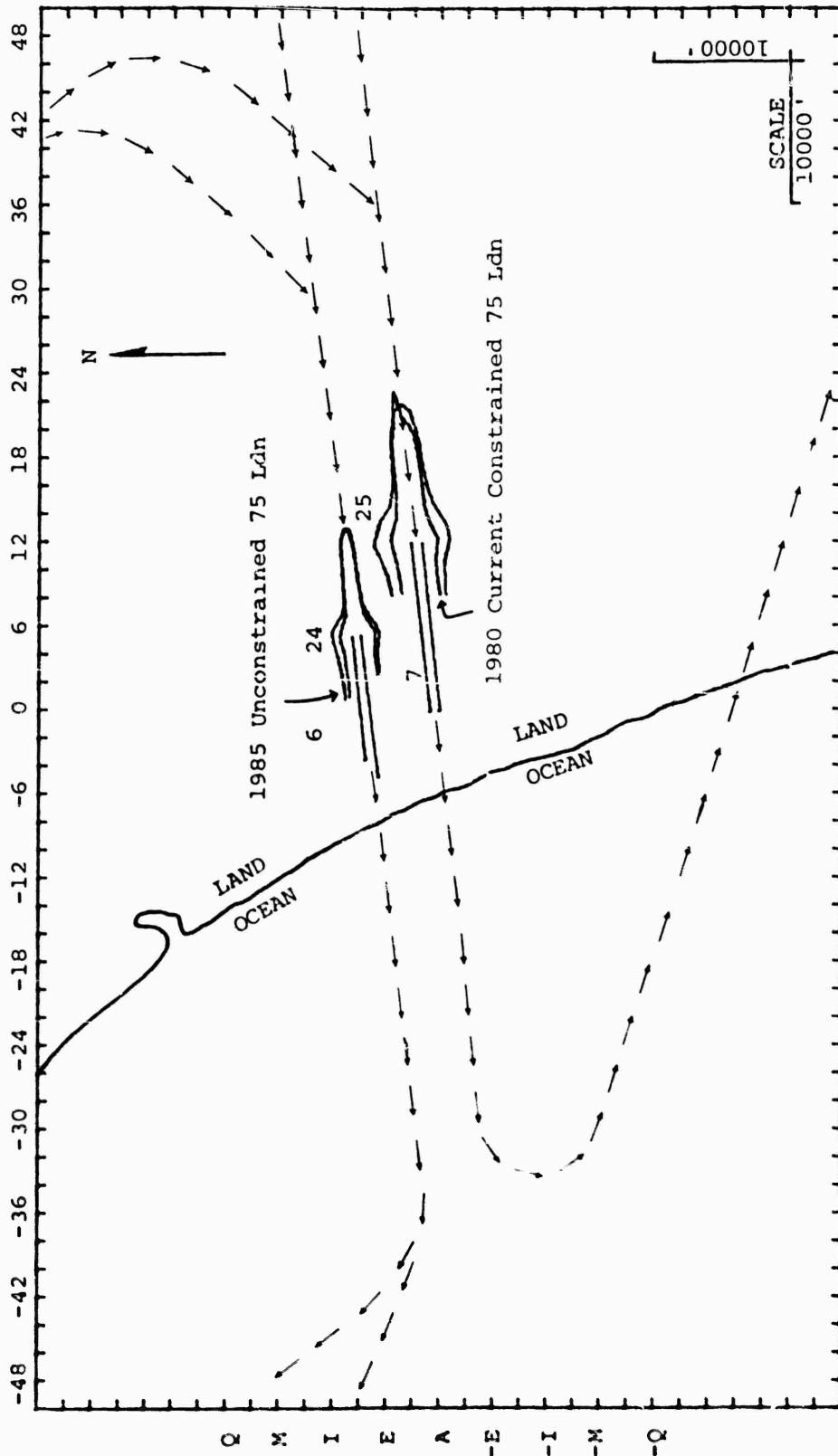

Figure 3.9 Los Angeles International Airport 75 Ldn
 Contour Plot Comparison of Constrained and
 Unconstrained Terminal Procedures

significantly greater than those solely attributable to the changing traffic mix (4.5 - 5.0 million gallons). As a matter of fact, the smallest additional savings is five times the magnitude of the traffic mix impact.

REFERENCES

1. "The Analysis of Integrated Fuel Efficient, Low Noise Procedures In Terminal Area Operations", McKinley, J. B., prepared by Systems Control, Inc. (Vt.), Champlain Technology Industries Division, for the U.S. Department of Energy, Contract No. DE-AC01-80C550141, January 1981.
2. "Airport Information File" Office of Environment and Energy, Federal Aviation Administration, May 1980.
3. "Compliance With Noise Standards By U.S. Domestic Operators Status Report", AEE, FAA, June 1980.
4. "Integrated Noise Model, Version 2". Office of Environment and Energy, Federal Aviation Administration, FAA-EE-79-09, September 1979.
5. "Energy Conservation in Terminal Airspace Through Fuel Consumption Modeling", Winer, D. E. and Hoch, C. J., AEE, FAA, SAE Technical Paper No. 800745, May 1980.
6. "Identification of Federal Aviation Administration Regulations and Procedures That Impact Fuel Consumption", McKinley, J. B., prepared by Systems Control, Inc. (Vt.), Champlain Technology Industries, Div., For the U. S. Department of Energy, Conservation and Solar Energy, DOE/CS/50066.001-1, October 1979.
7. "Examination of Commercial Aviation Operational Energy Conservation Strategies", Covey, R. R., et al., The Aerospace Corporation for the U.S. Department of Energy under contract Number EM-78-C-03-2184, October 1978.

PART II

DOT/FAA AVIATION ENERGY CONSERVATION POLICY

PRECEDING PAGE BLANK-NOT FILMED

AN OVERVIEW OF THE DOT/FAA AVIATION ENERGY CONSERVATION POLICY

Charles J. Hoch
Chief, Energy Division
Office of Environment and Energy
Federal Aviation Administration

PRECEDING PAGE BLANK-NOT FILMED

Introduction

Thank you and good morning!

I am pleased to have the opportunity to present an overview of the DOT/FAA Aviation Energy Conservation Policy.

The policy is broad--covering the general aviation as well as the air carrier segments of the industry--but my presentation will concentrate on the air carrier aspects in keeping with the theme of the conference.

Background

I would like to start out with a review of some of the statistics bearing on aviation's use of energy:

- First, from a macroscopic view we see from Figure 1 that petroleum represents about half (45%) of all U.S. energy consumed.
- Second, the total transportation economic sector--which uses petroleum almost exclusively--coincidentally represents about half (52%) of this country's total petroleum use (see Figure 2). We can just about provide for transportation's needs with our domestic petroleum production.
- But, we have to import almost as much petroleum as is used for transportation--to fulfill the needs of our non-transportation end uses.

Obviously, our petroleum import posture wouldn't be too bad if no other economic sectors of our economy required the use of petroleum, but this is not the case.

In fact, our total petroleum needs make us the leading importer of petroleum among all Nations. We accounted for a fifth of the 40.54 million barrels of crude petroleum and petroleum products imported daily in the world in 1978.

The results of our being on the wrong side of the petroleum import/export equation are all too familiar to you. High prices and spot shortages have evolved in most petroleum end use areas. These symptoms have surfaced regardless of the extent to which the "end use" consumes petroleum.

Even though aviation utilizes only 8% of all transportation's energy (see Figure 3), it has not been exempted from these impacts.

FIGURE 1

U.S. Energy Consumption by Type of Energy

(1980 Percentages)

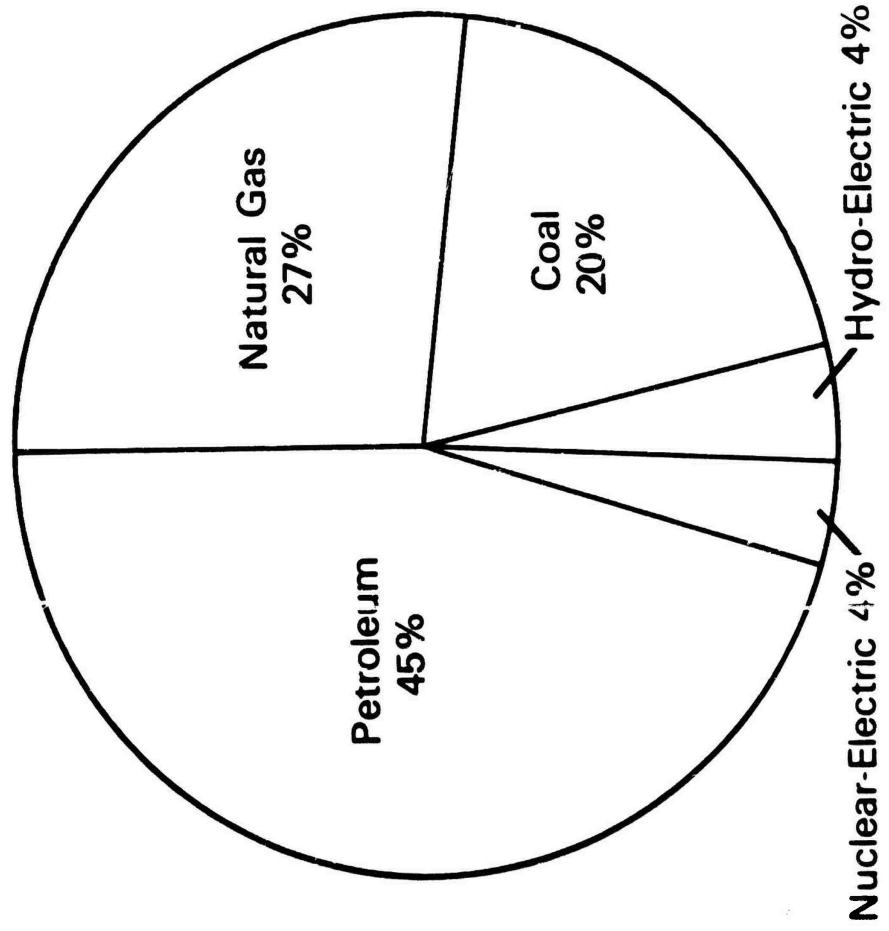

FIGURE 2

U.S. Petroleum Consumption by Economic Sector (1980 Percentages)

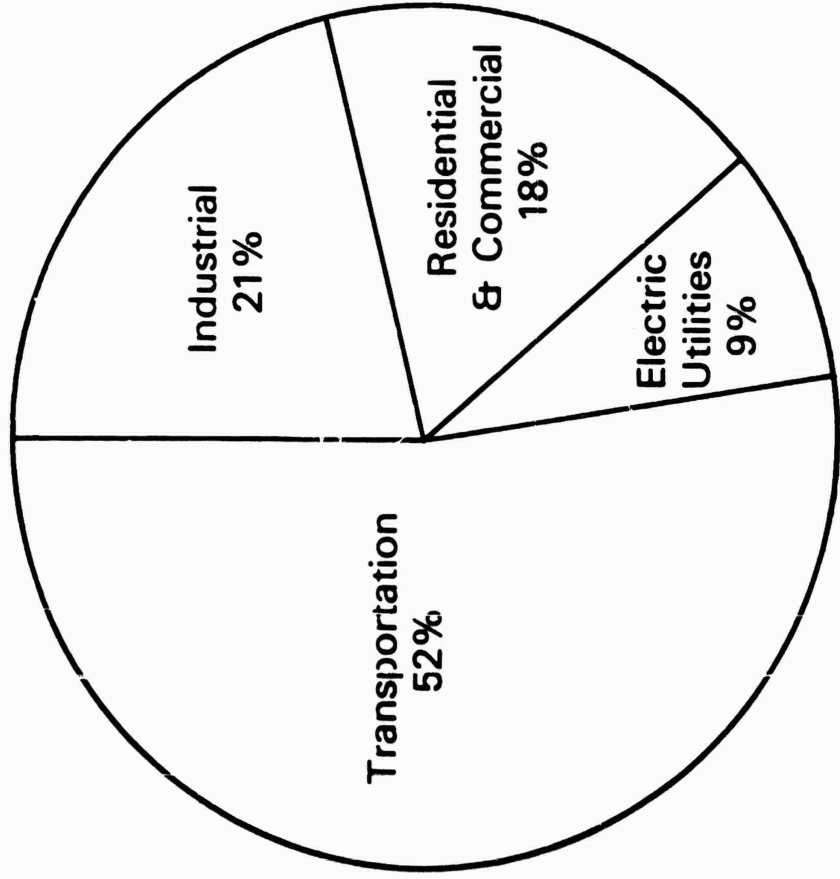
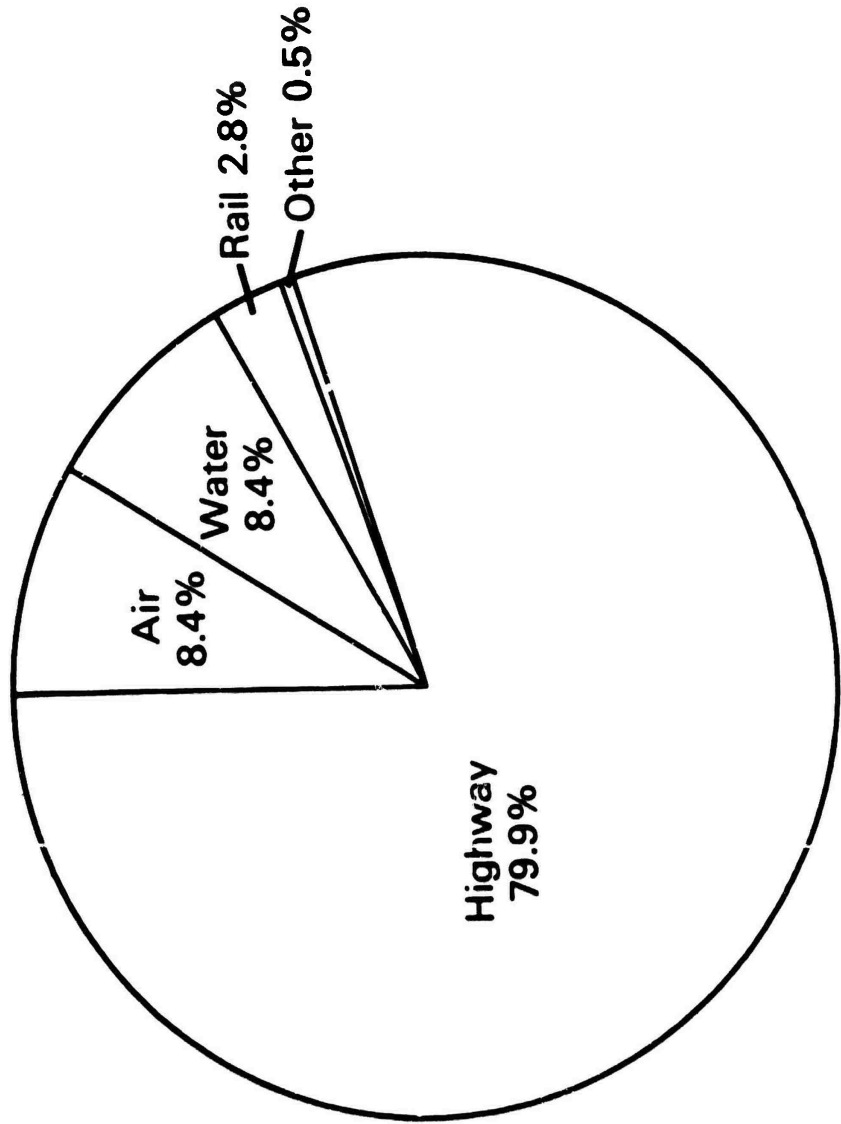

FIGURE 3

U.S. Transportation Petroleum Use by Mode (1980) Percentages



The bottom line of this petroleum "sellers' market" is evident in figure 4 illustrating the growth in airline fuel price between 1967-1980. Today, fuel costs account for over 30 percent of the airlines' total operating costs.

Very quickly we seem to have transitioned from the macroscopic to the microscopic point of our concern--aviation. This brings us to the development of the DOT/FAA policy regarding aviation energy conservation.

As an agency, FAA has not just awakened to the call to conserve energy. Many of our programs leading to increased system capacity, or decreased system delay have carried with them the joint benefit of greater efficiency or energy conservation realized by system users.

As a matter of fact, in response to the 1973/1974 oil embargo the FAA, in conjunction with the aviation industry, implemented a jet fuel conservation program which was designed to save almost 4% of total fuel consumed by the domestic carriers. Elements of that program included:

- Revised Gate Hold Procedures
- Revised Flow Control Procedures
- Optimum Cruise Speeds
- Revised Air Traffic Control Procedures
- Taxi with Fewer Engines
- Use of Simulators
- Airport Development

In addition to the FAA's 7-point program to improve air traffic control and aircraft operating procedures, the carriers' self-initiated actions contributed significantly to improved fuel efficiency. These actions included reducing the number of flights as a result of the oil embargo (thus increasing load factors) and the voluntary grounding of fuel-inefficient aircraft and airline investment in new, more fuel-efficient aircraft.

These early conservation actions were given new impetus by the Energy Policy and Conservation Act (EPCA) in December 1975. One of the mandates of the Act was a 10 percent improvement in energy conservation over the 1972 pre-embargo consumption levels. As a result of the prior commitment of the FAA and the aviation community to energy conservation, the results were impressive and exceeded the National goals. In fact, aviation fuel efficiency had already improved by 16 percent by the time the EPCA became law. This trend has continued as shown by the 39% percent increase between 1973 and 1979 in airline fuel efficiency illustrated in Figure 5. All conservation actions were designed with the specific requirement of avoiding any derogation of safety.

FIGURE 4

Airline Fuel Costs

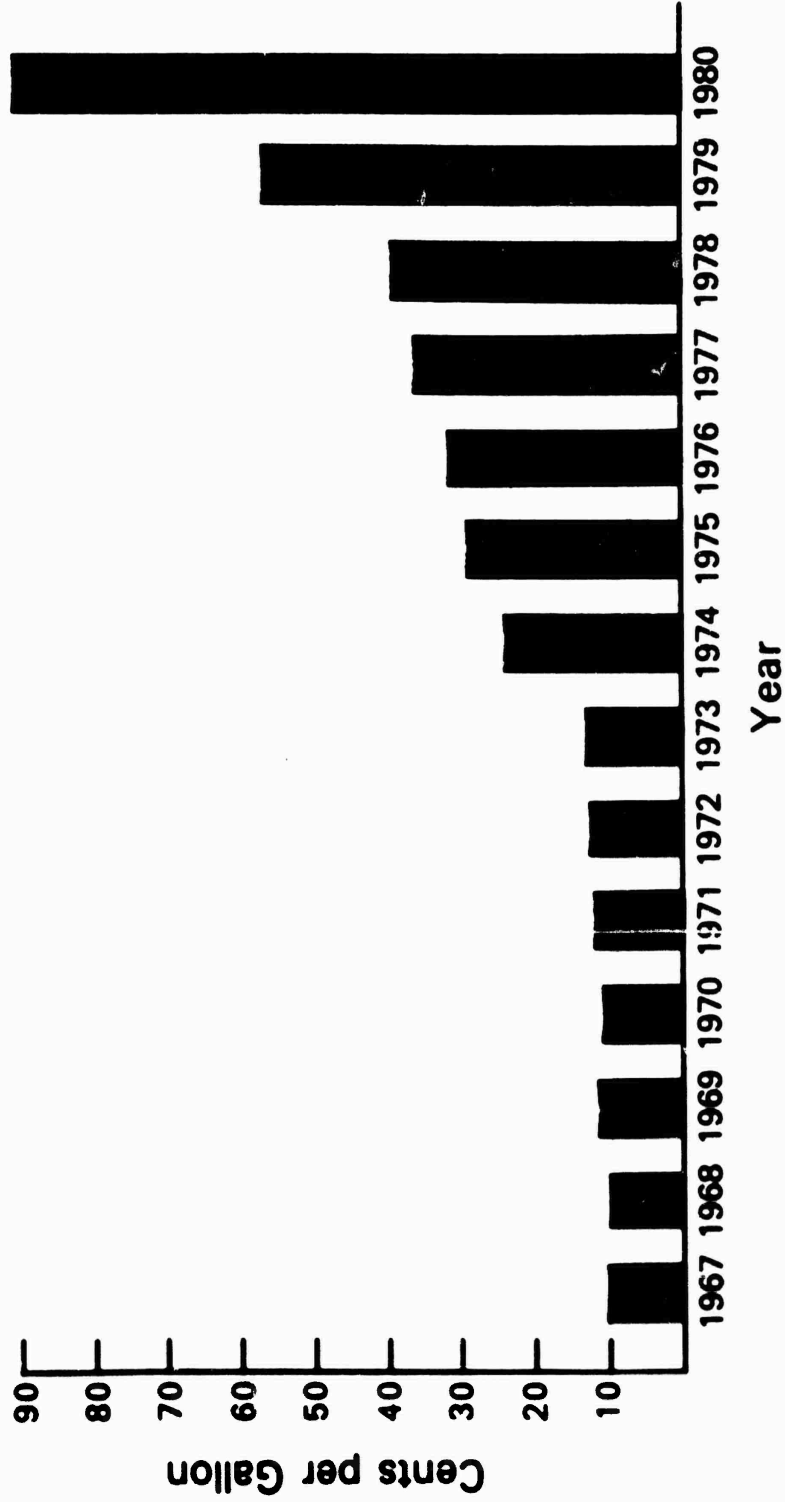
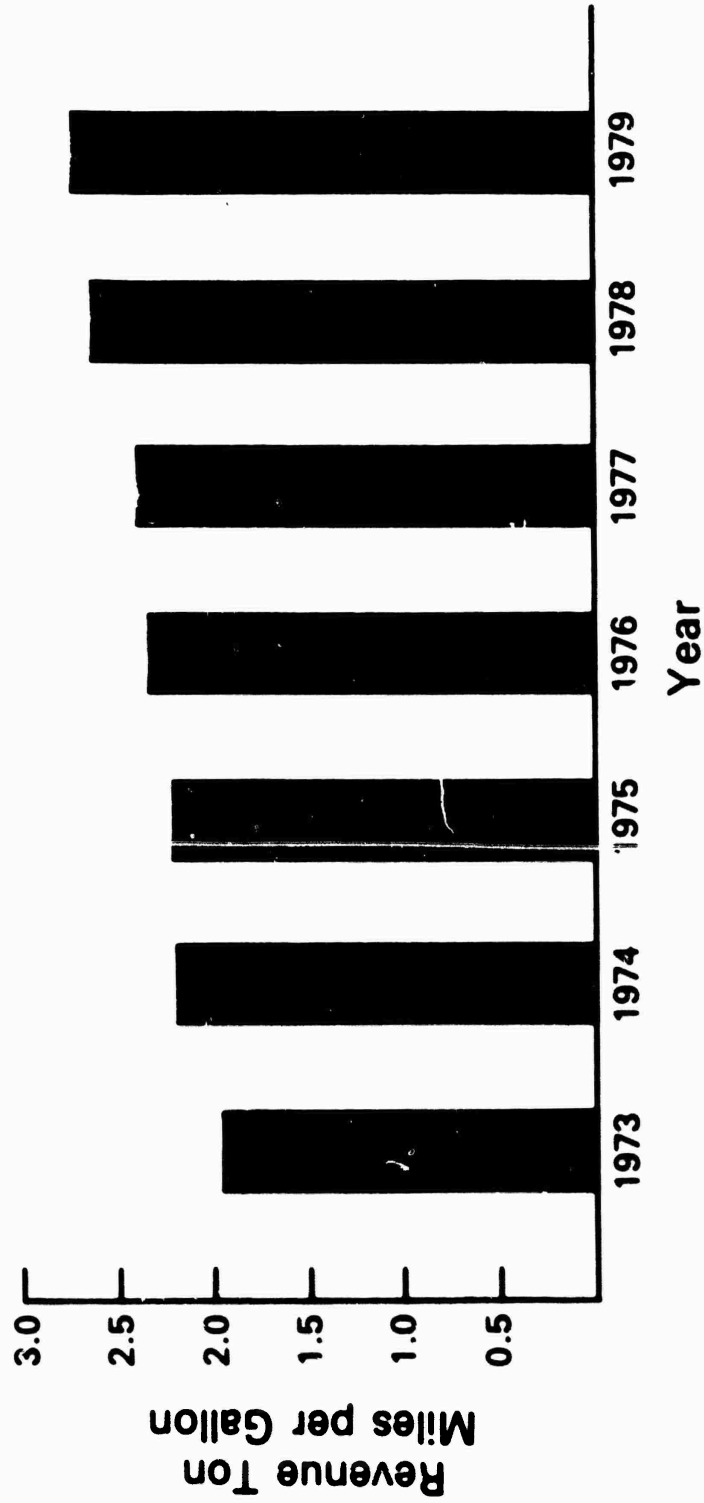

FIGURE 5

Domestic Air Carrier Fuel Efficiency



The Policy

Our policy statement briefly outlines the authorities and responsibilities of the various "actors" in the National Aviation System which impact energy conservation. These include:

- The Federal Government (primarily FAA, DOE, NASA and CAB).
- Aircraft operators (air carriers and general aviation).
- Airport proprietors.
- Aeronautical manufacturers and suppliers.

The basic principles upon which our policy is based are twofold:

1. The FAA will promote aviation energy conservation in both the present and future operation of the National Aviation System, by
 - (a) Supporting development and use of energy-efficient aircraft and aircraft operating techniques;
 - (b) Promoting the energy-efficient operation of the airport and airspace systems; and
 - (c) Conserving energy in the design, installation and operation of FAA system facilities and aircraft. And,
2. The FAA will act to insure aviation's equitable share of energy, by
 - (a) Supporting the short-term development and use of alternative fuels in other areas whenever possible in an effort to free petroleum-based fuels for aviation, and other users, which are vital to the Nation and for which there are not economically viable alternatives in the near term; and
 - (b) Supporting longer-term R&D efforts for development of future alternative aviation energy fuels.

Having established these principles it then became clear that our specific policy actions could be grouped into five program areas dealing with different aspects of the aviation system. The program areas we chose were these:

- Air Traffic Control (ATC)/Flight Operations Program
- Upgraded ATC Systems and Procedures
- Airport Program
- Aircraft Technology Program
- Internal FAA Program

Before listing the various actions I want to make three points about our policy.

First, the FAA has no authority to directly regulate the supply of aviation fuels. As a result, our policy primarily emphasizes energy conservation rather than expanding the fuel supply. The policy lists actions which can be undertaken by the FAA and industry as a result of existing authorities.

Secondly, the five program areas do not fall neatly within the purview of any single participant. For example, the FAA can implement many or all of the actions in the first category, ATC/Flight Operations, but the success of these actions depends on the extent to which aircraft operators cooperate to conserve fuel. Obviously, those program elements for which the FAA has sole responsibility can be implemented independently within existing authorities.

Finally, our policy includes a mix of voluntary, incentive, and mandatory programs to be pursued by the Federal Government as well as the aviation community. The policy is designed to encourage, not regulate energy conservation by the industry while committing the FAA to improve the operating environment for system users.

The 31 program elements are listed in Figure 6.

Many of the program elements have been implemented to some extent by the FAA or the industry, but are listed for the purpose of restating in one comprehensive document the FAA's support of such efforts. To help elaborate on some of our accomplishments an "Energy Kit" has been developed consisting of our policy and other information documents on this subject. Entitled, "Energy Conservation in Aviation," these kits are available to the public. A limited number of kits may be obtained at this symposium and others will be provided to individuals upon request.

To summarize the FAA policy: we believe that the aviation industry has taken and must continue to take the initiative to demonstrate that it will do its part to help use our Nation's energy resources more efficiently. The FAA will work within its jurisdiction to supplement the industry's efforts by providing the most efficient airport and airway systems possible.

In addition, we believe it is imperative that the appropriate authorities recognize the value of aviation to the Nation as well as the near-term dependence of aviation on petroleum. These facts must be reflected in any national policy regarding how energy is to be used in the United States.

We believe that with the support and participation of the organizations represented here, this policy will prove to be an effective one. Thank you!

Figure 6
 Summary of DOT/FAA Aviation Energy Conservation Policy

PROGRAM/ACTION	RESPONSIBLE GROUPS
A. <u>ATC/Flight Operations Program</u>	
1. Expand and Refine Fuel Advisory Departure (FAD) Procedures	FAA, Aircraft and Airport Operators
2. Promote Gate Hold Procedures	FAA, Aircraft and Airport Operators
3. Expand Local Flow Traffic Management (LFTM) Program	FAA, Aircraft and Airport Operators
4. Promote Fuel-Efficient Altitudes/Speeds	FAA, Aircraft Operators
5. Promote Effective Use of the Airspace	FAA, Aircraft Operators
6. Promote Reduced Tankering	FAA, Aircraft Operators
7. Expand Use of Simulators	FAA, Aircraft Operators
8. Promote Fuel-Efficient Taxi Procedures	FAA, Aircraft and Airport Operators
9. Promote Maintenance of Aircraft for Optimum Fuel Efficiency	FAA, Aircraft Operators
10. Promote Use of Inflight Computers	FAA, Aircraft Operators
11. Develop Energy Model for Optimum Flight Planning	FAA, Aircraft Operators, Aeronautical Manufacturers
12. Expand/Promote Energy Training Programs for Controllers/Aircraft Operators	FAA, Aircraft Operators

Figure 6 (Continued)
 Summary of DOT/FAA Aviation Energy Conservation Policy

PROGRAM/ACTION	RESPONSIBLE GROUPS
B. <u>Upgraded ATC Systems and Procedures</u>	FAA, Aircraft and Airport Operators, Aeronautical Manufacturers
C. <u>Airport Program</u>	
1. Require Energy Assessments for ADAP Projects	FAA, Airport Operators
2. Develop Energy-Efficient Ground Operating Plan for Washington National and Dulles International Airports	FAA
3. Promote Snow/Ice Removal Systems	FAA, Airport Operators
4. Evaluate Incentive Programs, Quotas and Slot Allocation Mechanisms for Reducing Airport Delays	FAA, Airport and Aircraft Operators
5. Continue the Airport Improvement Program to Reduce Congestion and Delays	FAA, Airport and Aircraft Operators
6. Promote Satellite Airports and Separate GA Facilities at Congested Airports	FAA, Airport and Aircraft Operators
7. Evaluate Aircraft Towing	FAA, Airport and Aircraft Operators, Aeronautical Manufacturers
8. Develop Energy Conservation Education Programs for Airport Operators	FAA, Airport Operators
9. Promote Energy-Efficient Airport Access Systems	FAA, UMTA, FHWA, Airport Operators

Figure 6 (Continued)
 Summary of DOT/FAA Aviation Energy Conservation Policy

PROGRAM/ACTION	RESPONSIBLE GROUPS
<u>D. Aircraft Technology Program</u>	
1. Promote Development of New Technology Aircraft, Engines and Aircraft Systems	FAA, NASA, Aeronautical Manufacturers, Aircraft Operators
2. Promote New Aircraft Designs with Extended Towing Capabilities	FAA, Aeronautical Manufacturers, Aircraft and Airport Operators
3. Support Development of Alternative Fuels	FAA, DOE, NASA, DOD
<u>E. Internal FAA Program</u>	
1. Promote Efficient Use of Energy in FAA Operations	FAA
2. Develop Energy Contingency Plan	FAA
3. Promote Energy Efficiency in ATC Facilities	FAA
4. Require Energy Assessment for ATC Facilities and Procedures	FAA
5. Develop Energy Models for Use in Energy Assessments	FAA, Aircraft Operators, Aeronautical Manufacturers
6. Monitor ATC Energy Conservation Programs	FAA

LUNCHEON REMARKS

Eldred N. Cort, Jr.
Planning Manager
Exxon Research and Engineering Company

April 2, 1981

PRECEDING PAGE BLANK-NOT FILMED

It is my privilege to be here with you today and to be part of this Symposium on Commercial Aviation Energy Conservation Strategies. You are addressing a very important subject, namely conservation. Due in large part to conservation, energy demand in the United States is expected to grow at a rate significantly lower than that experienced in the 13 year period prior to the Arab oil embargo of 1973. Conservation will have the effect of reducing demand. Our projections show that estimated energy demand in the year 2000 will be 34% less than the pre-1973 trend. Conservation is already occurring. The demand in 1980 was estimated to have been 12% less than the pre-1973 trend. All sectors of the economy will contribute to this reduction.

Demand reductions in the residual and commercial sector reflect actions such as adjusted thermostat settings and more efficient heating, appliances, and structures.

In the industrial sector, savings result from better energy management, the retrofitting of industrial equipment, and the development of new, less energy intensive processes.

In the transportation sector, demand reduction results from improved efficiency in all modes of transportation. Improvements in automotive efficiency get the most attention from the news media, but the airlines have also made contributions. The jet fuel demand in 1980 was down slightly, yet the passenger miles traveled increased. This is due to efficiency improvements you are discussing at this meeting plus increases in the passenger load factor.

Conservation is important, but it must be accompanied by development of new energy supplies--they are alternatives to each other. Therefore, I would like to address the comparison of alternative aviation fuels. Since we will be in a transition period for several years, I will also cover the outlook for future trends in the quality of petroleum-derived jet fuel.

Since this is a luncheon talk, I would like to start with a story before jumping right into the technical details. In trying to come up with a story that would not offend anyone, I came up on the following oldie.

A Yankee farmer took his wife to an aviation field where pleasure ascensions were made daily. He asked the price of a trip aloft and was told that the charge would be ten dollars for a ten-minute trip.

"Ten dollars for a ten-minute ride?" exclaimed the farmer. "Why, that's a dollar a minute. There would be no pleasure in that for me. But I've always had my heart set on riding in one of them pesky things. Ain't there no way you could reduce the price for me, neighbor?"

"I'll tell you what I'll do. If you will agree not to say a word all the time we are in the air, I will not charge you anything. But if you say anything while we are up there, it's going to cost you the full price."

"You hear that, don't you, Ma," said the farmer to his wife.

"Yes, Hiram," replied the wife, submissively.

They were soon tucked in the plane and soaring over the countryside. When the plane had reached an altitude of 3,000 feet, the aviator began his efforts to make the yankee shout. He did the loop-the-loop, the tail spin, the barrel roll, and falling leaf--all the veteran trick flyer could command. But the farmer remained silent throughout the ordeal. At last the aviator gave up and returned to the ground.

"Well, you've won," said the aviator as the farmer untangled himself from the fuselage of the plane, "and the ride is yours, free of charge. I must congratulate you on your pluck, man."

The farmer smiled proudly, and replied, "Yep, I reckon so; but I tell you, you almost caught me there once, when the old lady fell out."

You may have heard about the two hot air balloonists who were enjoying a flight when it clouded up so much that they were lost in the clouds. In fact it became so bad that they had to come down below the clouds to try to find their bearings. After a while, they realized they were lost and they happened to spot a fellow in a field. They decided to descend and check with him on their location.

They landed and asked the gentlemen, "Where are we?" The fellow looked at them and thought a minute, then replied, "You are in a hot air balloon." The pilot turned to his co-pilot and said, "That fellow must be a lawyer--his answer is precisely correct, but completely irrelevant."

The outlook that I will be discussing won't be precisely correct because none of us knows what the future holds, but I hope that you will find the information germane.

I don't need to tell this group that the United States and all of the free world has a serious energy problem with regard to transportation fuels. One of the important segments of the transportation sector is commercial aviation. In the United States, commercial aviation was the third major user of transportation energy, exceeded only by the automotive and trucking industry. The current energy source for aviation is petroleum. With world-wide petroleum supplies expected to peak in the next ten to twenty years, and with the

long lead times of ten to fifteen years for the development of a new aircraft, it is important to consider now the use of alternative fuels. So, today I want to cover with you two major topics: the trends of future qualities of petroleum-derived jet fuels, and secondly, a comparison of alternative aviation fuels.

Supplying jet fuels to the airlines and to the military in the next ten to twenty years presents the petroleum industry with a challenge. This challenge is a result of changing demand patterns and crude supply sources. From a demand standpoint, gasoline demand is down in the United States and distillate demand is up. While crude availability is not a problem at the present time, over the long haul we see that world-wide crude supply will be chronically tight and more and more of the marginal crudes will be heavy and high in sulfur, which will put strains on the processing industry.

The shifting pattern of product demand will affect the quality and availability of jet fuels in the coming decade. Less gasoline demand means more virgin cuts for jet fuel blending. Also, there will be less hydrogen available from naphtha reforming for treating the distillate.

The use of heavier crudes and changing fuel oil demand patterns will require the use of more coking and cracking processes in the refineries. This will tend to produce more high sulfur, aromatic, and olefinic distillate cuts. Improving the quality of the distillate in terms of stability, sulfur content, and other air quality factors, will require more hydrotreating and the use of additional hydrogen. Thus, priority on the use of available hydrogen will be for desulfurization, not hydrogenation of aromatics. The net effect is likely to be that the producibility of jet fuels may be limited by aromatics level.

To remove or saturate these aromatics will require a quantum investment in hydrogen manufacturing and high pressure hydrogenation facilities, steps which will consume energy and increase costs. I'm sure you know that the present jet fuel specifications limit aromatics to 20% max or 25% on a reportable basis. The trend in reportable fuel delivered has been one of increasing percentage of jet fuels that is above the 20% limit. I understand that about 10% of the jet fuels supplied are above the 20% limit. This is not only a trend that is occurring in the United States, but also one that is occurring in Canada and other locations. This is a trend that we would expect to see continue. Thus, we see that there is an incentive to be able to use these aromatic jet fuels from the standpoint of both availability and cost.

There are also other fuel properties that may change in the future --such as an increase in the freeze point and a lowering of the flash point. Both of these changes would be made to increase fuel availability.

I'd like to now move into the second part of my talk with you this morning and that is the area of alternative jet fuels. We recently made a study for the Department of Energy (DOE) on this subject, which serves as the basis for this talk.

I think it is fairly well realized that in some point in the future, it will be necessary to switch over to non-petroleum derived fuels. As I mentioned earlier in the talk, it is generally believed that production of conventional petroleum on a world-wide basis will peak somewhere between 1995 and 2010, indicating that there will be severe difficulty in meeting the world-wide demand for petroleum very early in the 21st century. If one assumes that it takes around 10 years to design a new aircraft, this means it would be about 1990 or 1991 before the aircraft will be in production, assuming that it starts now, and that these aircraft would continue to be in use until around 2020. This says that any new aircraft designed today, based on conventional petroleum, could run into serious problems in availability of jet fuel before its lifetime is half over. Thus, with the long lead time for the development of new aircraft, we feel that it is important to look now at the use of alternative fuels. Will they be similar to today's fuels or will they be radically different?

Future alternative aircraft fuels for gas turbines fall into two basic types: synthetics, which include shale oil distillates, coal liquids, from either the direct or indirect process route, and tar sands liquids. And the second major category of cryogenics, which includes liquid hydrogen and liquid methane.

The synthetics can be refined to have properties which are very similar to today's jet fuels. On the other hand, since aviation is weight-limited, liquid hydrogen has always looked attractive from the standpoint of it having the highest heat of combustion on a weight basis. This means that you can get the most Btu's into your engine for the lowest weight of fuel. Liquid hydrogen has also looked attractive because it has a high specific heat, which is a measure of its ability to be used as a coolant, primarily in supersonic flight.

Liquid hydrogen has two disadvantages: the density is low compared to synthetic liquids and its boiling point is very low, around -430F°. Liquid methane by comparison to liquid hydrogen would be classified as a mild cryogenic liquid. Liquid methane is about six times as dense as liquid hydrogen but it is only 42% as energetic as hydrogen on a weight basis.

Thus, while the cryogenic fuels would appear to have some very attractive physical properties, it is necessary to look at the cost of operating aircraft with these fuels, looking at the cost both from a dollar standpoint and a resource requirement viewpoint.

Trying to estimate the future costs of alternative fuel is a very difficult job, and I would like to try to put them into perspective by using relative costs rather than absolute costs. If we look at the relative ranking of the cost of the various alternative fuels that I have mentioned, we would see that shale liquids would be the lowest cost, followed by direct and indirect coal liquids, followed by the cryogenics with liquid methane around 2-2 1/2 times more expensive than shale, and liquid hydrogen the most expensive at around 3 1/2 times the cost of shale distillate on an energy basis.

If one considers the cost of the basic resources and this includes combining the process thermal efficiency with the energy required to transport and to upgrade the fuel, we see that shale also is the most attractive, coal liquids next, and liquid hydrogen the most energy intensive.

The next question, then, is how does the cost to operate an aircraft compare with these various fuels. We addressed this problem in the study for the DOE for both subsonic, as well as the supersonic aircraft. For the subsonic case, we looked at an aircraft carrying 400 passengers, 5500 nautical miles, flying at about 0.85 MACH number. In this case, the aircraft using liquid hydrogen would have the lowest weight, which means it would also require the lowest thrust per engine. The airframe manufacturers have estimated that the subsonic aircraft would cost the same whether it was built for use with either liquid hydrogen, liquid methane, or the synthetics. Based on this aircraft data, then, we have calculated the relative cost per flight for each one of these types of fuels. We found that shale liquids would have the lowest relative cost rating, with coal-derived liquids second, and liquid hydrogen being the most expensive. For these reasons, we have concluded that liquid hydrogen would not be attractive for subsonic aircraft.

In comparing the cost data for supersonic aircraft, it has been estimated that a liquid hydrogen supersonic aircraft would cost only about 3/4 that of a synthetic fueled aircraft. Even taking this into account, we concluded that the shale liquids would again be the most attractive, followed by the coal liquids with liquid hydrogen a little more attractive now than in the case of the subsonic aircraft.

Of course, liquid hydrogen does have some advantages from an environmental standpoint, and from the standpoint that longer range flights are possible than for the synthetic fueled aircraft due to the higher energy density of liquid hydrogen. Thus, if the choice is between coal liquids and LH₂, for a supersonic aircraft flying at 5500 miles, liquid hydrogen would be more attractive. However, if shale-based products were available at the cost we have assumed, liquid hydrogen would lose its economic advantages, even at a 5500 mile range for supersonic aircraft.

Since we have concluded that the synthetics would make the most attractive jet fuels, we have also looked at some of the properties of these future synthetic fuels. The synthetic jet fuels from coal generally will have a hydrogen content of around 7-10% before upgrading to the current level of around 14% hydrogen. Now, the cost to add hydrogen can be appreciable, costing as much as \$1.85/million Btu or 23¢/gallon, to bring the hydrogen level from 10 to 14%.

An alternative to adding hydrogen would be to develop an engine to operate on a lower hydrogen fuel. The experimental multi-zone combustors being developed as part of the NASA experimental clean combustion program have shown that the maximum combustor liner temperature is insensitive to fuel hydrogen between the 10 and 14% hydrogen range, compared to the conventional single zone combustor.

While these experimental combustor systems themselves may not be suitable, information has been published on the estimated incremental costs to produce these new engines, the increased maintenance cost, and any fuel penalty. We have taken this information and made an economic comparison between upgrading the coal liquids and modifying the engine. We find that there is a before tax incentive of almost a half a million dollars a year per engine to modify the jet engine to use a 10% hydrogen fuel rather than upgrade the coal liquids to 14% hydrogen. We certainly feel that there is an incentive to look at this further and to make trade-offs between upgrading the synthetics to meet today's specification compared to modifying the engine.

Let me summarize for you the main points of this talk on the outlook for petroleum-based jet fuels and alternative fuels.

The petroleum outlook is one where conventional crudes will become tighter in supply and they will become heavier and higher in sulfur. Coupled with the change in crude supply will be the change in the demand pattern, with less gasoline demand and increased distillate demand. This increased distillate demand will be reflected in the use of distillates in the automotive sector, the petrochemical sectors, as well as for jet fuels. You will see increasing competition from various users for the same part of the petroleum barrel that jet fuels are derived.

As a result of all of these changes, we are likely to see that the jet fuels will become higher in aromatics. To meet the current specifications will require refining investments and therefore an increase in the cost to reduce the aromatics to current level. The producibility of jet fuels may also be restricted by aromatics. Thus, there is an incentive to use more aromatic jet fuels from the standpoint of availability and cost.

In the case of alternative fuels, we see that there may be some shale distillates used in aviation between 1985 and the year 2000. In fact some synthetics from tar sands are being used currently in Canada on a very small level. The distillates from shale are likely to be incorporated into existing refineries and so it will be difficult to separate what is a jet fuel molecule made from shale and one that is made from crudes. Past the year 2000, we feel that liquid synthetics from either shale or coal make the most sense from an economic and resource utilization standpoint. Therefore, synthetics will be the alternative fuels for aviation in the future; we do not see liquid hydrogen as being attractive unless there is the need for long-range supersonic flights.

We also see an incentive to develop a jet engine to use fuels with a lower hydrogen content rather than upgrade the synthetic fuel to meet the current hydrogen level. Thank you.

PART III

FLIGHT OPERATIONS AND AIR TRAFFIC CONTROL

Airline Flight Planning - The Weather Connection

Robert Steinberg

**Lewis Research Center
Cleveland, Ohio**

PRECEDING PAGE BLANK-NOT FILMED

Abstract

Airline flight planning has shown little improvement in accuracy since the introduction of computerized techniques in 1964. This has primarily been, because both the type of weather product utilized by the carriers and the way they have employed it has remained unchanged over the past 15 years. The airlines now have an opportunity to make a significant advance in this area with attendant benefits in fuel savings. Most of the technological ingredients are in place, but it will take increased cooperation between government and the private sector if cost effective improvements are to be made on a reasonable time scale. This paper reviews the meteorological basis for the present method of flight planning and analyzes its impact on current flight operations. A new approach is suggested for developing a weather data base, for flight planning, which has the potential of providing a fuel savings of between 2 and 3 percent on long distance flights.

Background

Over half a century ago, when scheduled airline services began, flight planning was rudimentary and the weather data upon which it was based was almost nonexistent. Weather observations were infrequent and data collection and distribution means were primitive. The unique requirements of aviation were slowly recognized, but even by the late 1930's flight planning had shown little improvement, because the observational basis for forecasting was still inadequate. The airlines relied chiefly upon upper air information provided by pilot balloons and scattered reports from aircraft.

By the early 1950's, the situation had changed substantially. There was a reliable synoptic network in place, providing upper air reports, flight planning was much improved, and a reasonably accurate method had been developed to calculate minimum time routes. Although attempts made to develop an empirical approach to forecasting were far from being satisfactory, the impact of numerical prediction methods were beginning to be felt, and it seemed only a matter of time before an accurate flight plan would be available.

The next 15 years saw a rapid growth in commercial aviation. With the introduction of the jet engine, aircraft flew longer, faster and higher than ever before. Airlines introduced computer techniques to flight planning which improved the quality and generally resulted in a more uniform and timely product. Large numbers of flight plans could now be generated with the potential for human error reduced considerably. Weather services had to adapt and develop very quickly to meet the new demands of commercial aviation. As a result, they improved their numerical prediction (NWP) models and in 1969 established direct computer-to-computer transmission of digital wind and temperature data to air carriers. By 1972, the coverage provided by the NWP model was nearly complete for the northern hemisphere and so the first fully automated flight planning systems were operational.

Other changes were also occurring which were to have an indirect but nevertheless important impact on flight planning. Airline communications were improving, longer range aircraft were becoming available and a number of countries now began providing terminal and in some cases even upper air forecasts. The requirements for dispatchers/meteorologists in the field began to lessen and as a consequence most European, as well as several U.S. carriers eliminated their meteorological staffs. As fuel costs also began to rise, all personnel including meteorologists was reduced. In the United States, the attitude was somewhat ambivalent. The approach carriers took ran from total dependence on the digital forecast with no human intervention, through little more than providing an amendment service, to manually developing a separate upper air forecast. Except for fully automated operations, all other approaches have usually been people intensive and as such have repeatedly come under the scrutiny of cost conscious airline managements. A number of voices were raised challenging the efficacy of these reductions, however, carriers caught in a budget squeeze would not reverse policy without proof that maintaining a meteorological staff was cost effective; although some tried, no definitive proof was forthcoming. The prevailing winds of change were in the direction of automation.

Events also seemed to convince a number of remaining carriers that total automation in flight planning was almost at hand and was indeed the only viable alternative. The 1970's saw the development of weather satellites and the introduction of additional sophistication in NWP techniques which made possible more accurate upper air charts as well as an improved mid range forecast for 24 to 48 hours. These events plus the increasing cost of jet fuel encouraged some airlines to make still further reductions in their meteorological staffs and the way the remaining personnel were to be utilized. Ironically, the impact of all this activity on flight planning has been slight and the overall accuracy attained today is similar to that of 20 years ago.

Analysis of the Problem

An efficient airline flight plan requires a reasonably accurate space and time picture of the atmosphere through which a flight is to take place. The fact that this has not always been possible has primarily been because of (1) the type of weather product utilized by the carriers and (2) the way the carriers have employed it in developing their flight plans. The real impact of both these decisions on airline operating costs only recently begun to be felt. However, with hindsight, it should not have surprised anyone that a numerical forecast on the synoptic scale should have failed to provide a data base for accurate flight planning, especially in a high fuel cost environment.

When fuel represented only a small percentage of airline operating costs, the weather service's forecast model seemed to meet most airline needs, particularly since it provided the basis for a fully automated flight plan at little or no cost. The fact that the forecast was on a synoptic scale (500-5000 km.) and that large scale models of this type required a settling down period of perhaps 6 to 12 hours seemed of little consequence. Advances in numerical prediction models have taken place and the spatial resolution has been improved, however, we are still dealing basically with a forecast on the synoptic scale with its inherent spatial and temporal limitations. This means that large scale features such as ridges and troughs are usually well defined. However, other characteristics such as precise location and intensity of jet streams, frontal systems and regions of sharp gradients which are critical input for accurate flight planning, and are mesoscale phenomena (20-500 km.) cannot be seen with sufficient resolution. Clearly, broad scale synoptic developments exercise a controlling influence, and are extremely important, but within this framework there are mesoscale features that will inevitably be lost or smoothed out when modelling with grid points 300 or even 200 km. apart.

The availability of forecasts based on observations taken at 12 hour intervals coupled to the problem of initial adjustment has meant that most international carriers flight plan on an 18 to 24 hour forecast. Given the fact that weather systems can change dramatically within a 6 to 12 hour period, it becomes even more understandable that the present approach to providing weather data for flight planning has some important limitations. If numerical modelling on the synoptic scale is to provide the basis for accurate airline flight planning, then some cost effective way must be found for retaining important mesoscale features, while at the same time providing more frequent updates of the forecast.

The way carriers have used the forecast, has also played an important role in accurate flight planning and was an early indicator that a potential problem existed. Those carriers which employed the digital forecast, directly without any human intervention, believed that the synoptic scale forecast met their needs the majority of the time and was the most cost efficient way to operate. Other carriers which used the forecast to verify the large scale motions of the atmosphere and provided a meteorologist to integrate those mesoscale features important to carrier operations thought that putting a man in the loop provided a more accurate flight plan and was more cost effective. It is generally agreed that the latter approach will usually result in a better flight plan. However, since this method is people intensive, the real question has been, is it cost effective?

Preliminary NASA Findings

Preliminary results from the NASA Commercial Aircraft Fuel Savings Program¹ suggest the following:

- (1) Air carriers are paying a high price in excessive fuel burn by flight planning on "old data" (18 to 24 hour forecast). On the North Atlantic this translated to a potential trip fuel savings alone of between 2 and 3 percent (see Appendix A). On other (lower data density) routes the potential savings could even be greater.
- (2) Inserting mesoscale data (from aircraft) into a synoptic scale forecast model along major air routes such as the North Atlantic will have little impact on flight planning (see Appendix B). This is primarily because the data is smoothed out and the impact on the forecast is slight, and suggests that providing high resolution (mesoscale) wind and temperature data may not be cost effective using the present forecast product².

These preliminary findings indicate that the "freshness" of the data is at least as important as its spatial resolution and if we hope to take advantage of high resolution data we will have to find a way other than direct insertion into a synoptic scale NWP model.

Data Base

In order to consider mesoscale phenomena in flight planning we, of course, need observations on the mesoscale. Presently in the northern hemisphere, in many areas the synoptic network is very good, however, data is not usually available on the mesoscale except from aircraft and satellites. In the southern hemisphere, the situation is much worse and there are many areas which are data sparse and where data on any scale is almost nonexistent. Input data with good time resolution are, of course, just as important as data with detailed spatial resolution. The timeliness of the data also plays a critical role in accurate flight planning.

¹ NASA Commercial Aircraft Fuel Savings Program was developed specifically to determine the impact of high resolution near real-time wind and temperature data on airline fuel savings. A final report is expected by November 1981.

² This work was performed using the U.S. National Weather Service's 9 level primitive equation NWP model.

Another important consideration is that between 20 and 25 percent of the pilot-reports (PIREPS) are in error³. These errors are, in the main, the result of data handling and transmission problems.

A System Problem

It is clear that a way needs to be found to (1) obtain more data on the mesoscale along airline routes (2) retain the observed details with a minimum of smoothing and (3) get the information to the carriers with fewer errors, more quickly and more often. The spatial and time resolution, of the data, as well as its timeliness and availability each play a key role in providing the basis for a more accurate flight plan. In short, its a system problem and must be attacked as such. Improvements in the observation network without corresponding improvements in the data processing or mode and frequency of delivery will result, as we have seen over the past 15 years, in little improvement in flight planning and hence fuel savings for the carriers.

The air carriers, for their part, also have a system problem. They need to review their methods and procedures in a number of areas if they are to take full advantage of an improved weather product for flight planning. These areas are the following:

1. Review algorithms used to provide both spatial and time interpolation of weather data. Data from the NASA Aircraft Fuel Savings Program (see Appendix C) indicates that a number of air carriers were using incorrect algorithms in their flight planning and were flying fuel inefficient routes as a result.
2. Review procedures for developing flight plans to assure that they are developed on the latest available data and are not generated too early.
3. Review communications procedures between the carrier and the weather service and within the carriers flight planning delivery system. It makes no sense to provide an improved weather product on a more frequent basis if this advantage is lost because of a communications limitation, i.e., the weather service transmits data to the carriers at 1050 baud in the United States (the British weather service will transmit at 2400 baud). This means a full hemispherical upper air forecast takes between 1-1/2 and 2 hours to transmit domestically (overseas it is averaging 3 hours). This is unacceptable.

³ Private communication from the National Weather Services in the United States and England.

4. Review procedures requiring flight plans to be available four hours before departure on international flights. Some carriers have cut this requirement to between one and two hours and have found no difficulty.
5. Carriers should, either individually, collectively, or through their representatives, maintain a sufficient level of competency in meteorology so as to understand the details of the basic products provided by the weather services. They should be aware of the assumptions made in the NWP models and their impact on flight planning so as to be able to anticipate and advise the carriers of potential problems and to make clear and coherent recommendations to the weather services on behalf of the carrier or carriers.
6. Review software documentation relating to flight planning so that modifications resulting from new developments (i.e., interpolation techniques) can be quickly implemented with a minimum of delay.
7. Collective efforts must be made to provide air traffic control centers which use a weather product to develop moveable track systems to be more time responsive. Greater interest shown by the carriers (direct discussions, visits) could be very effective in initiating change.

Opportunities for a New Approach

The key points in the previous analysis are:

1. Accurate flight planning will require meteorological information on a finer scale than can be provided by a synoptic forecast.
2. The way a forecast is employed has an important impact on flight plan accuracy. Keeping a man in the process can provide a more accurate product, but is it cost effective?
3. In the future, more accurate flight planning will depend upon the availability and timeliness of mesoscale data along major airline routes.
4. Development of a more accurate flight plan will be very dependent upon a systems approach being adapted by the National Weather Services and the carriers.

Options

If numerical models are to provide a data base with the required detail for accurate flight planning, then a way must be found for retaining the mesoscale features. There are a number of ways this could happen;

MAN - COMPUTER INTERACTIVE TECHNIQUES APPLIED TO UPPER AIR FORECASTING FOR FLIGHT PLANNING

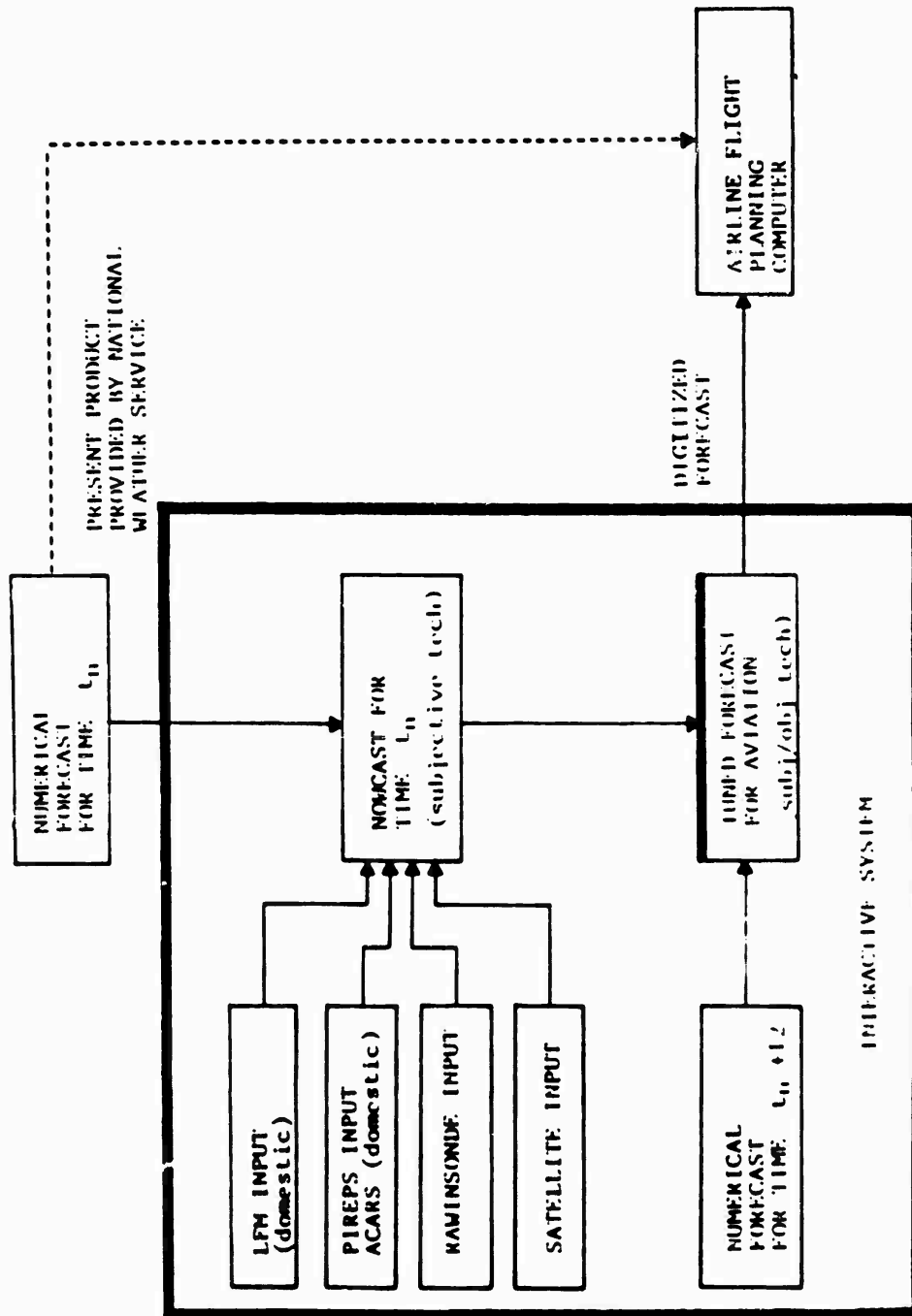

FIGURE 1

1. Development of a hemispherical mesoscale forecast model.
2. Use of Limited Area Fine Mesh Models.
3. The development of a Man-Computer Interactive Display System applied to upper air forecasting.

Mesoscale Numerical Weather Prediction Model

The development and operational use of a hemispherical forecast model on the mesoscale, (assuming the availability of a data base on that scale) given the present and near term computer capabilities, will probably not become a reality during the remainder of this century. There is also the question of whether it should even be developed or it can really be justified on a cost benefit basis.

Limited Area Fine Mesh Models

Providing a Limited Area Fine Mesh Model (LFM) for selected areas such as the North Atlantic may be a viable alternative over the next decade. The effectiveness of this approach will depend on the resolution of the NWP model and the input data. An LFM is currently operational for the continental United States and provides forecast fields 4 hours after synoptic time and should be given serious consideration by domestic air carriers (preferably eastern carriers) for flight planning.

Man-Computer Interactive Display Systems

The Man-Computer Interactive Display System (McIDAS) concept developed at the University of Wisconsin (1) was an attempt to retain the best that both the computer and man had to offer in developing an accurate information base. Applying this technique of optimizing the man-machine mix to upper air forecasting for flight planning, will make it possible to integrate large quantities of seemingly dissimilar data, rapidly and efficiently by automating the repetitive tasks while enabling the meteorologist to retain and facilitate the use of his judgment in a highly effective manner. Figure 1 shows a schematic of how interactive techniques could be applied to upper air forecasting. The solid line encloses the interactive components and the broken line indicates the present operational computer-to-computer link used in automated flight planning. This new approach has the potential of making available a significantly improved weather forecast and providing from this product an accurate and cost effective flight plan with the present as well as future data bases.

A forecast on the synoptic scale (as discussed earlier) is designed to provide a reasonably good three-dimensional picture of large scale motions of the atmosphere and then translate this picture in

time, but it is limited in detail, the very ingredient necessary for accurate flight planning. Pilot reports are more timely and accurate but limited in spatial distribution. Rawinsonde data are accurate but their time and space distribution is poor. Satellite data is timely and can often provide additional information on the location of jet streams. In essence, these seemingly disparate sources of upper air data complement each other and need to be analyzed together to provide consistency. Man-computer driven interactive display techniques has the potential of meeting this requirement in a most efficient and cost effective way.

A meteorologist, using interactive techniques, could develop an accurate nowcast (current situation) using a forecast, pilot reports, rawinsonde and satellite data. It is anticipated that by using a combination of subjective and objective methods, it is possible to provide a forecast for the next three, six or twelve hours (2). This data would then be digitized and provide the basis for automated flight planning. In effect we are describing the development of a tuned forecast based on sophisticated software techniques designed specifically to meet the needs of the aviation community. A product which up to now has not been available and one that is urgently needed.

Using Interactive Techniques with the Present Upper Air Data Base

Interactive techniques can be employed with the present NWP model in a very effective way. The ancillary data base (in the domestic case) could consist of the current LFM forecast output, rawinsondes, pilot reports, ACARS (ARINC Communications Addressing and Reporting System), PIREPS, and satellite data. Complementary fields could be displayed on the same space scale, animated forward or backward in time and modified using both subjective and objective techniques. The key ingredient in this system is the development of an effective software package to provide the proper mix in the generation of an optimal forecast. An effective interactive system would have editing capabilities which would provide for software modification to meet changing requirements and allow for evolutionary development in an operational environment by the carrier. The system should also not be computer limited in order to provide for an increased data base as well as multi-terminal expansion.

Interactive Techniques and Future Data Base Improvements

Interactive techniques can only mirror the quality of the data which is inputted. As the importance of higher spatial resolution and more timely data become generally recognized and the option to provide this improvement is exercised (i.e.; ACARS down link and/or transponder equipped aircraft providing near real-time fully automated air reports) the quality of the forecast provided by interactive techniques will reflect this improvement. The increase in the synoptic data base will make the availability of multiple objective analyses, perhaps at three hourly intervals, worth considering. These analyses could then form the basis for the nowcasting requirement for interactive techniques. At this point it is anticipated that benefits

would be derived in reduced reserve fuel as well as trip fuel and that the overall fuel savings for air carriers using these advanced techniques could be greater than 4 percent⁵.

Implementation of Interactive Techniques

A number of carriers in the United States maintain a meteorological staff solely to provide terminal and severe weather forecasting. Interactive techniques can play an important role in these areas in providing for more effective use of available manpower and vastly improved utilization of meteorological information. Because of this, it is anticipated that some of these carriers will obtain interactive systems and begin to explore these capabilities in an operational mode. The step from this application to employment in developing upper air forecasts for flight planning is significant and most carriers will not have the in-house technical expertise to develop the appropriate software.

Had the advantages of interactive techniques to upper air forecasting been recognized earlier, perhaps National Weather Services would have already developed the appropriate subjective/objective techniques including the software. However, for many reasons this has not been the case. This is particularly unfortunate because logic would have dictated that a centrally located interactive system for upper air forecasting would have provided the most cost effective approach for the aviation community and avoided much system duplication. The reality of it is, however, that a number of carriers would still acquire interactive systems for terminal and severe storm as well as upper air forecasting because of company policy.

Perhaps one or two carriers because of their past commitment to meteorology and the obvious advantages of interactive techniques, will want to move into this area early. However, much of the required expertise in NWP models and interactive techniques resides within government and the universities; and much of the present experience using interactive techniques has been in improving weather diagnostics given large sets of satellite imaging data, and has been carried out in an off-line research mode. In order to assure that the United States aviation industry has the opportunity to benefit on a reasonable time scale, from interactive techniques, it is important that we develop experience with this system, in upper air forecasting, in a real-time operational environment. It would seem that a cooperative effort between the carriers and government/universities may be the most timely way of responding to this need. An alternative approach could be through ARINC (Aeronautical Radio Incorporated), a company

⁵ Unpublished manuscript dated December 10, 1980, written by Edward Carlstead, Chief of Forecast Division, United States National Weather Service.

set up by the airlines to avoid duplication and inefficiency in meeting the needs of carriers. However, historically, ARINC has only interfaced with the private sector.

The rising cost of fuel will force many carriers to reevaluate their long term requirements in this area and hopefully take concerted action. It is estimated that an interactive system to provide upper air tuned forecasts, including manpower for 24 hour operation would cost about 600 thousand dollars per year after a one time capital investment for equipment of about one million dollars. An international carrier with a present fuel bill of one billion dollars could expect to save at least 20 million dollars per year on trip fuel alone (see Appendix A). When one considers the potential for optimizing reserve requirements, the savings could even be considerably higher. It is clear that in a cost conscious deregulated environment, carriers should give man-computer interactive techniques careful and in depth consideration.

Systems Approach - Carriers, Weather Services, Air Traffic Control

Interactive techniques are only one part of the solution. The observing system, the quality, quantity, timeliness and the NWP model as well as the communications networks used to provide this data all play an important part in making it possible to generate a more accurate flight plan. It is essentially a systems problem and will require a comprehensive solution. Half way measures will provide limited results.

The carriers as well as air traffic control (ATC) will have to review their time lines and adjust their procedures in a number of areas to take advantage of a better weather product. For example, Gander and Prestwick ATC currently set the east and west bound flow, respectively, for over 300 flight per day across the North Atlantic on a forecast which is between 24 and 30 hours old. There is a need for a continuing dialogue between the appropriate government agencies and the carriers in all these areas and there is a need for action on both sides.

Conclusion

It is clear that many carriers have been moving in the direction of fully automated systems in their approach to flight planning. The pendulum has swung too far and it will be necessary to put the man back in the system in order to provide a cost effective approach to accurate flight planning. The way the man is used, however, must also change. The introduction of Man-Computer Interactive Video Techniques to flight planning and weather related flight operations will make it possible to fully utilize the meteorologist in a way never before possible, and provide the first real advance in this area in almost two decades.

A number of carriers may resist this change and adopt a wait and see attitude. With today's economic problems this is understandable. However, a few carriers will recognize early that in a deregulated, high fuel cost, environment, interactive techniques have the potential of providing a distinct competitive advantage to their operations over those carriers who will insist on still using a computer-to-computer operation for flight planning purposes.

Those carriers who elect to consider interactive techniques for their flight planning should be aware of the fact that much of the required software has yet to be developed. This is not a difficult task, but one that may require cooperation between the carriers and government.

Acknowledgements

The assistance of many people made this paper possible. Mr. Donald L. Nored, Chief of the Transport Propulsion Office as well as the Management of Lewis Research Center have been very supportive of this work in airline flight operations. The managements of KLM, TWA, Delta, British Airways, Swissair, SAS and VIASA to mention but a few carriers have cooperated wherever possible, as has the governments of Canada, Great Britain and the Netherlands. Drs. John Brown and Ronald McPherson and Mr. A. Desmaris National Weather Service have been extremely helpful in making available forecast rerun data. Mr. Anthony Broderick and Mr. Charles Hoch of the Federal Aviation Administration have played an important role in making this effort possible, and Mr. Allan White of the Civil Aviation Authority in England has also been of significant assistance in this work. Last but certainly not least has been the support of NASA Headquarters and in particular Mr. Allan Tobiason.

References

- (1) Chatters, G. C. and Suomi, V. E. 1975 Am. Inst. Elect. Electron. Eng.s. Trans. Geosce. Electron GE 13, no. 3, 137-146
- (2) Browning K., Steinberg, R., and Carpenter, K. M.; Interactive Techniques Applied to Upper Air Wind Forecasting for Flight Planning. Paper to be presented at International Conference on the Aviation Weather System May 4-6, 1981, Montreal, Que., Canada
- (3) The FGEE Special Observing Systems, Implementation Operations Plan World Meteorological Organization, Part E: Aircraft Integrated Data System vol. 5 May 1978

Appendix A

In order to evaluate the impact of higher resolution and more current meteorological data on airline fuel savings, the following comparisons were made; Operational computer derived Minimum Time Track (MTT) data developed for flights between New York and London was compared with a manually generated MTT. The operational MTT's were based on a 24 hour Suitland forecast. The manually produced MTT's were derived from the most current aircraft data available, valid at the time of the forecast. Figure 1 shows the results of 18 cases (all Monday's) between February 26, 1979 and October 2, 1979. In all but two cases the MTT's developed on current aircraft data were shorter. There was an average 4.2 percent savings in time by using an MTT developed on current data. The maximum displacement difference between the manual and computer produced MTT was about 5 degrees (between 50 and 10 degrees west).

The purpose of this comparison was to see if, under the most ideal circumstances, substantial gains in fuel savings were possible. The time savings generated on this basis should only be used for guidance, because of the following:

- (1) Time is not directly transferable to fuel burn
- (2) Air traffic control has not been factored in
- (3) PIREP data is not now available in near real-time

The "current" aircraft data base used for the manually developed MTT's was generated from about 75-100 standard PIREPS and about 100-250 additional high resolution (200 km.) automated aircraft observations. Often the spatial and time resolution were far from ideal and it was clear that further improvement in the MTT may be possible. Figure 2 shows a typical manually developed MTT for the North Atlantic⁶. The spatial limitations in the wind observations are obvious. The high resolution data was obtained, on the average, from only 10 to 20 aircraft. Normally 100-200 aircraft are crossing the North Atlantic in any given 12 hour period.

The spatial resolution (200 km.) of much of the data is considerably better than that normally provided on the North Atlantic (700 km.). However, it is evident from displacement results that a major impact of the data comes from its age, and improvements in this area can be most effective.

⁶ Manual MTT's provided under contract.

MINIMUM TIME TRACK COMPARISONS FOR NORTH ATLANTIC EAST-BOUND FLTS

AIR TRAFFIC CONTROL (ATC) DEVELOPED MINIMUM TIME TRACKS (MTT's) BASED ON SUITLAND 24 HOUR FORECAST VS. MTT DEVELOPED ON DATA, VALID AT TIME OF FORECAST

(minutes)

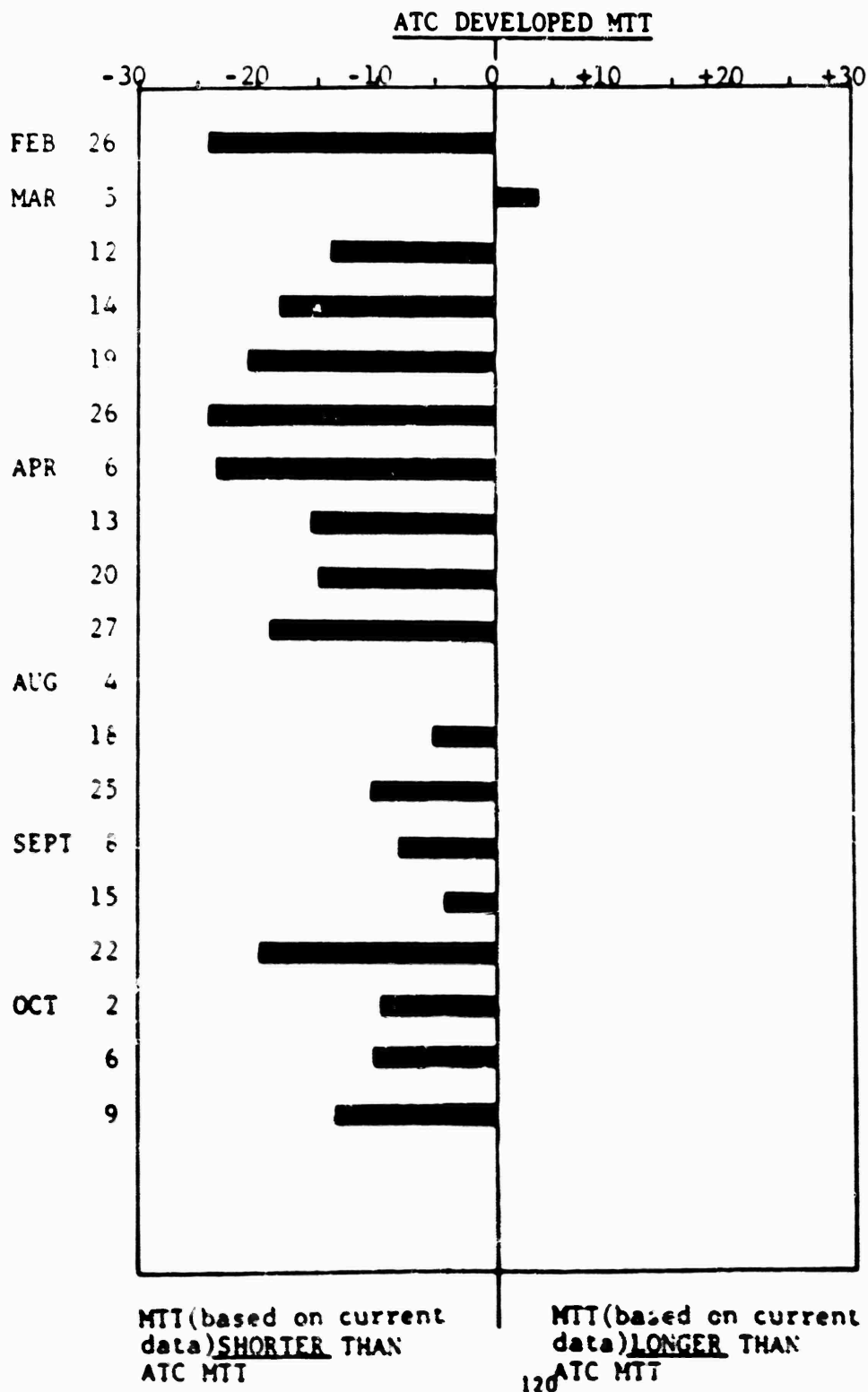

FIGURE 1

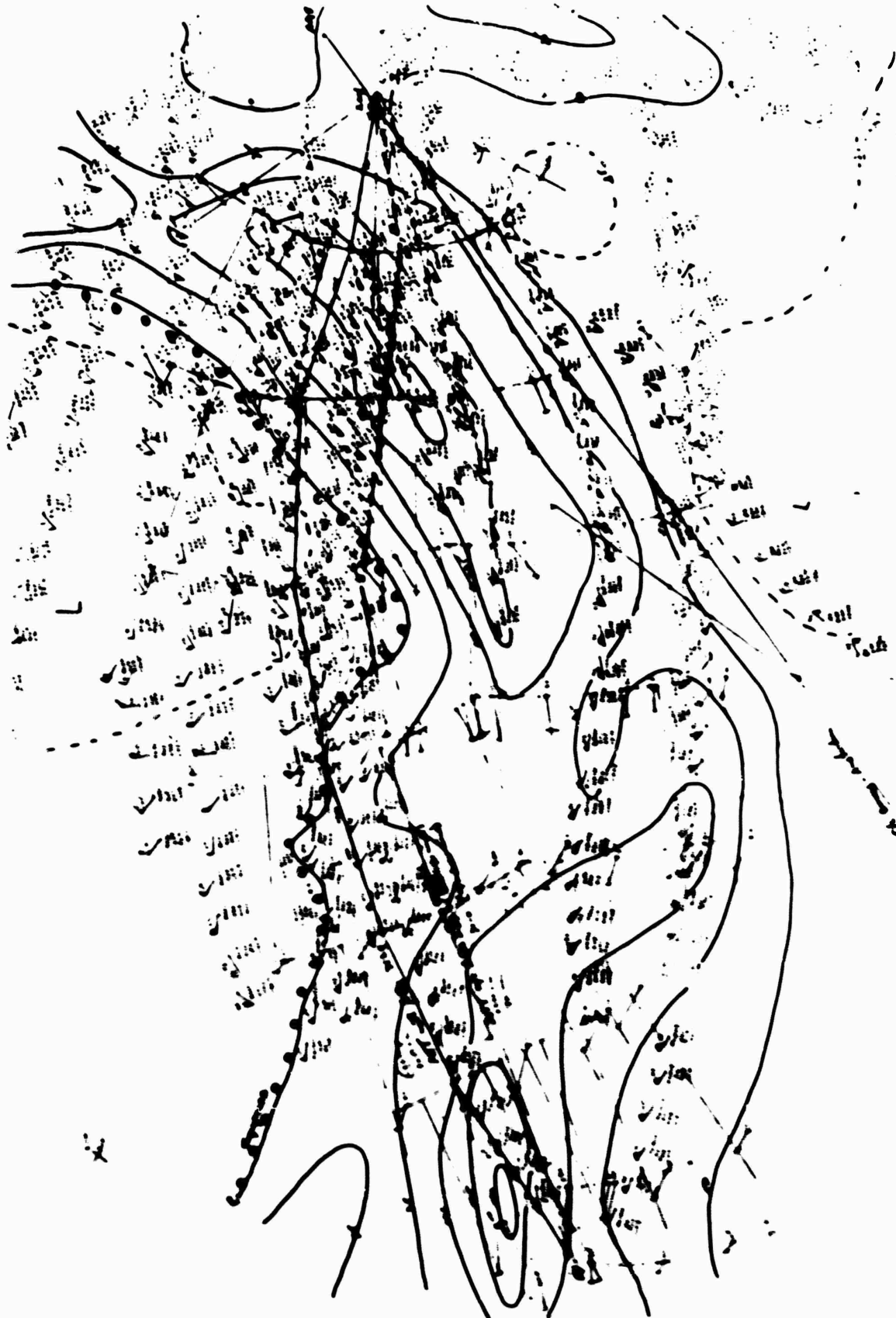

FIGURE 2. Shows a typical manually derived MTI for the North Atlantic. The limited coverage area for the wind observations is ~~SHOWN~~ly evident. Two MTI's with a 13 minute differential are

Appendix B

NASA, in cooperation with the World Meteorological Organization, set up a program to provide automated high resolution air reports, in non real-time, from eighty B-747 and DC-10 aircraft (3). The data was provided as part of an international meteorological experiment during 1979. This aircraft data was utilized in the NASA Commercial Aircraft Fuel Savings Program in a mock-up of an operational system to determine the impact of high resolution near real-time data on aircraft fuel burn. The National Weather Service in cooperation with NASA used this data to provide analysis reruns for comparison with the operational forecast. Comparisons were developed for 12, 18 and 24 hours after observation time and isotach difference fields were generated to show the influence of the high resolution data. Preliminary analyses of these fields indicate that the impact of high resolution observations (in data rich areas such as the North Atlantic) are small. Figure 1 shows a typical case. An alphanumeric field is used to indicate wind speed differentials (in knots). A map is superimposed over the field for ease of area identification. In most reruns, a total of between 200-400 observations were added to the existing data base, filling in between the normal PIREP reporting points (PIREPS are required at 10 degree intervals) on the North Atlantic. In many of the cases examined to date, the influence of high resolution data on the analyzed winds, as can be seen from figure 1, averaged only about 2-3 knots.

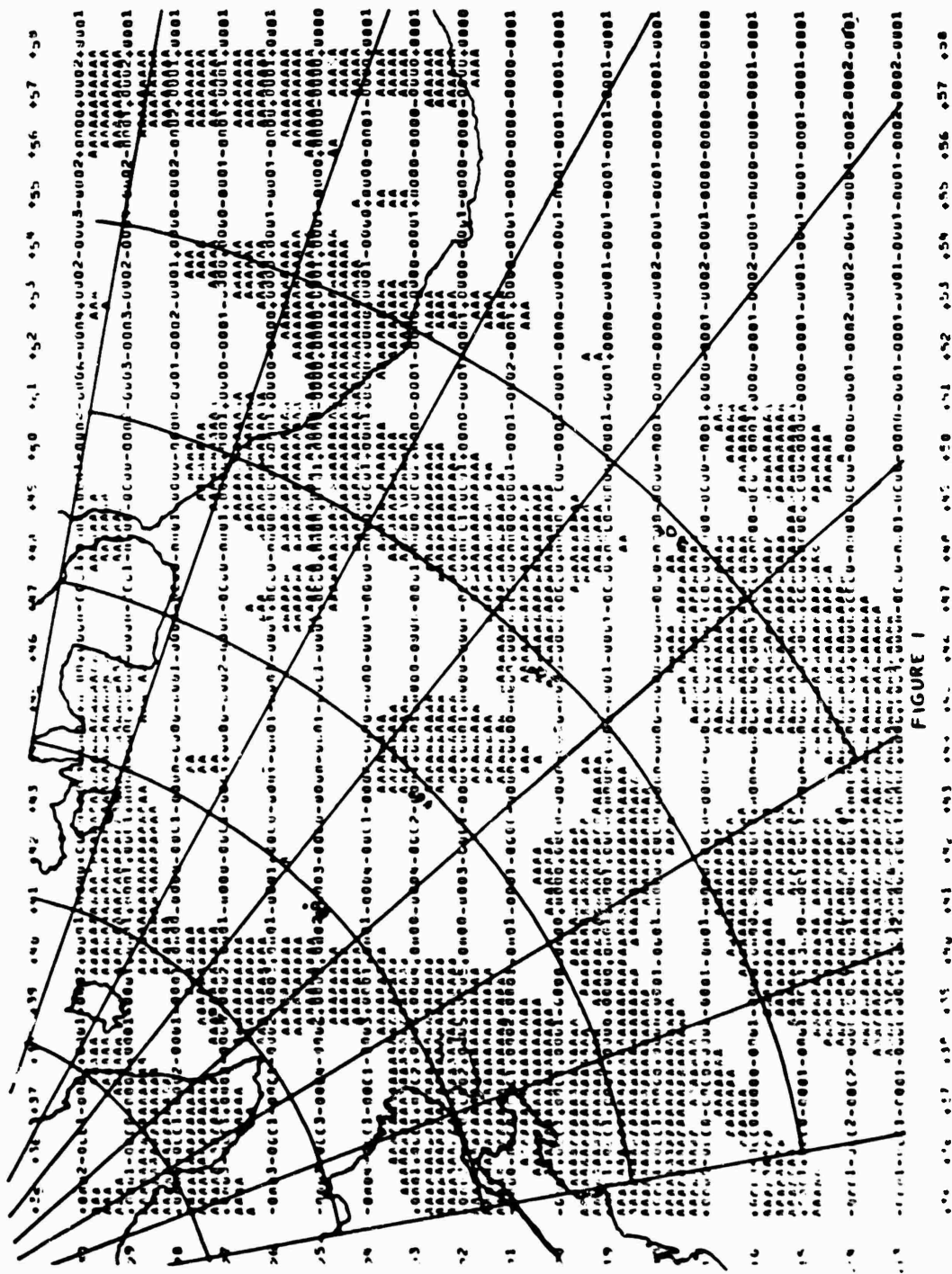

FIGURE 1

ISOTACH DIFFERENTIAL ANALYSIS NEMUS OPTICAL ANALYSIS

NO. ATLANTIC, KNOTS

Appendix C

Each day, about 14 hours before departure time a number of air carriers file a route request with Prestwick Air Traffic Control in preparation for west-bound flights across the North Atlantic. This data was analyzed basically for London - New York routes, although several cities adjacent to London were also considered. A preliminary analysis was carried out using information developed over an 8 month period. The route requests represented the air carriers Minimum Time Track (MTT) or Minimum Fuel Track (MFT) depending on company policy. The data was supplemented in a number of cases with 350 mb winds for verification purposes. Figure 1 shows a typical case where a carrier had requested an incorrect MFT. Most of the route requests are bunched together and the erroneous request readily stands out. The route letter designations refer to the particular forecast model used, by the carrier, in generating the route request.

The results to date indicate that three out of the eight air carriers studied were providing erroneous MFT's to Prestwick. This has been independently verified in two out of three cases. There is strong evidence that these errors in flight planning are the result of (1) incorrect algorithms used to interpolate wind and temperature data and (2) errors related to processing of meteorological data after it leaves the National Weather Service, but prior to receipt by the carriers.

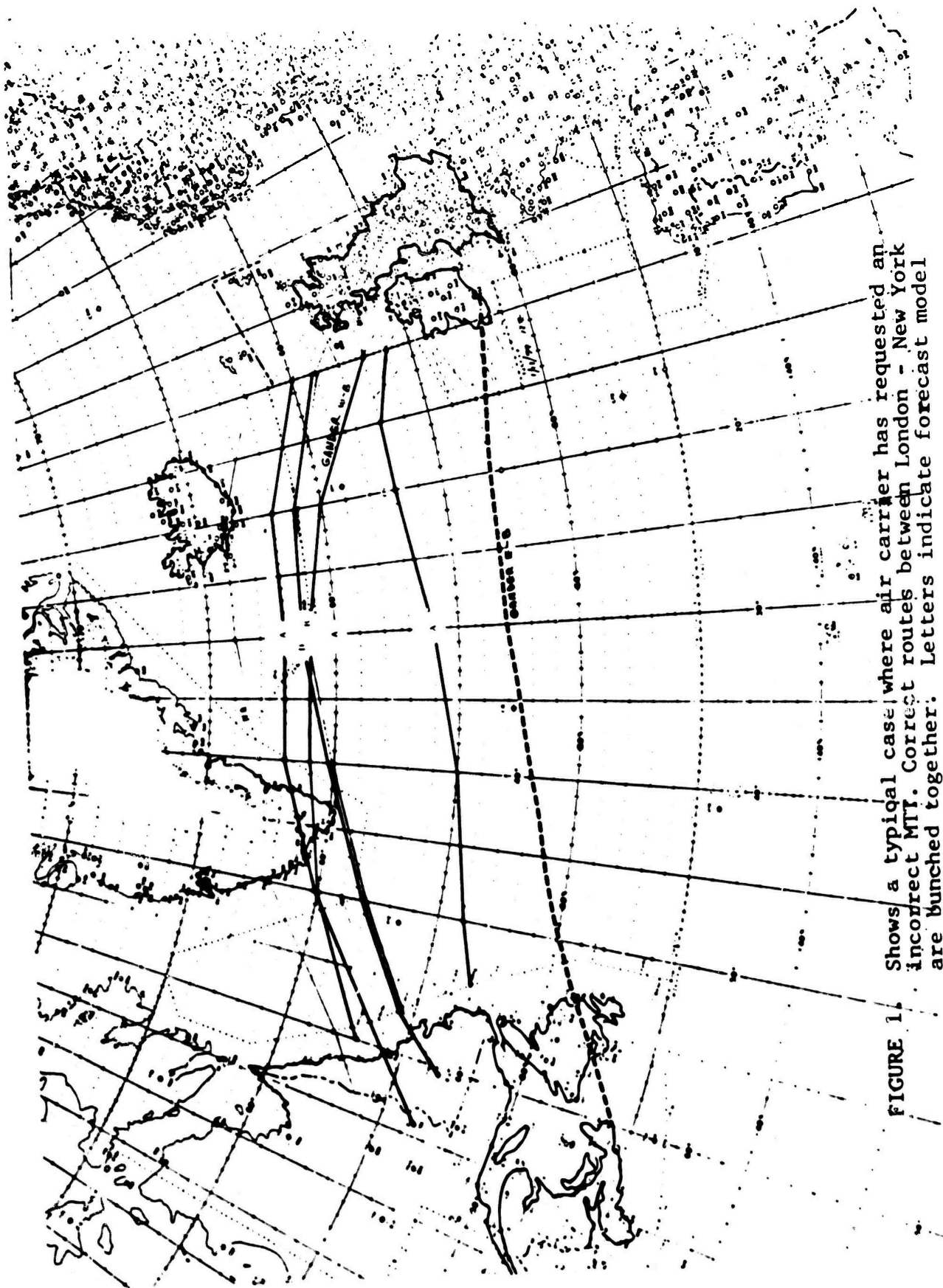

FIGURE 1. Shows a typical case where air carrier has requested an incorrect MTF. Correct routes between London - New York are bunched together. Letters indicate forecast model used.

FLIGHT PREPARATION AND PLANNING

by

Brooks Schooley
Staff Engineer
Flight Standards and Procedures
United Airlines
Denver, Colorado

PRECEDING PAGE BLANK-NOT FILMED

In 1979 United's fuel bill was 800 million dollars. This year it is projected to be 1.6 billion dollars - doubling in only two years. With the exception of a small amount of fuel used for maintenance and flight test, that 1.6 billion dollar expenditure of fuel is very close to the accumulation of burn-out appearing on one year's flight plans. The leverage the flight plan exerts upon fuel usage is enormous. United Airlines' flight plans are produced by AFPAM. AFPAM-Automated Flight Planning and Monitoring. They are computed on a Univac 1108 computer at the rate of approximately 1200 per day for 10 different airplane types. With fuel costs escalating as they have, the ability to flight plan to the most accurate and efficient extent possible becomes ever more important. In our operation, for example, a one knot change in forecast enroute winds will cause the fuel loaded aboard the entire fleet for one day to fluctuate about 26,000 pounds. Another reason accuracy is important is to assure flight crew confidence. The more credible the flight plan, the less need to add to fuel reserves for uncertainties. It requires an additional 9000 pounds of burnout per day to carry each additional 100 pounds of fuel loaded across the fleet. With such impact, flight preparation and planning is continually reviewed for improvement. Today we will begin by discussing the data base from which the flight plan is constructed, how corporate policy affects selection of a flight plan, the computation of the plan, and finally its operational application.

The data base used to construct the flight plan consists of airplane performance data, forecast weather data, city-pair route data, the corporate flying schedule, and some other miscellaneous information. The basic airplane performance data is initially supplied by the airframe manufacturer. This data consists primarily of climb cruise and descent data for airline established policy speeds. Climb data consists of time, fuel, and distance for a given weight and altitude at maximum climb thrust. Descent data also includes time, fuel and distance for an assumed idle thrust descent. In cruise, specific range data is provided for the appropriate range of weights and altitudes from a minimum speed of long range cruise up to the policy speed in .01 Mach increments. Another set of stored data is the maximum initial cruise weights. This is the airplane weight for a given altitude and temperature at which the airplane can sustain level flight at cruise Mach number and maximum cruise thrust. The remaining data consists mostly of airplane limitations and various parameters needed for peripheral activities associated with flight planning. Examples include maximum takeoff weight, maximum landing weight, holding fuel flows, minimum fuel reserves and so on.

The data is stored by airplane/engine type and remains relatively static over the life of an airplane. Exceptions to this occur when policy speeds are changed or there is a recognition of engine or airframe deterioration. This deterioration is caused over the life of the airplane by increased fuel flow

and drag from dirty or worn aerodynamic surfaces, leaking pneumatic systems wear on engine blades and so forth. The result is an increase of fuel burn over the manufacturer's original burn for the same set of conditions. To identify this deterioration, a rather extensive data gathering and processing system has been established. Various data parameters are recorded by flight crews in flight and later fed into a ground based computer. Using this data the computer compares various fuel burn characteristics against the airplane's past history, the remainder of the fleet, and the baseline data used for flight planning. When sufficient differences exist between the airplane and the flight planning data, the flight plan data base is updated. Only our 747 fleet has not indicated a burnout deterioration since its introduction. The B-727 and DC-10 fleets fuel burn has been degraded approximately 3%. Our 737's degraded 4.8% and DC-8's degraded 2.5%. The performance data is stored as polynomial curves in the computer. This form of data storage reduces both execution time and volume of data required.

United subscribes to the National Weather Service for its weather forecasting. The National Weather Service makes available to interested users a large volume of forecast upper air data in a digital format. The forecasts are derived from data observed over much of the globe and sent by means of a high speed communications network to a central computer for processing. The observations are fed into the computer in which wind and temperature forecasts are computed for flight levels of 18,000, 24,000, 30,000, 34,000 and 39,000 feet over the total forecast area. The forecasts are transmitted to United's computer twice daily starting at about 0630Z and 1830Z. When received from the National Weather Service, company meteorologists refine the information. This is accomplished using weather data periodically reported from company "honker" flights which are flights equipped with Inertial Navigation Systems. Every fix in the company route structure uses the data interpolated from the National Weather Service Information. Other data associated with operation of the airline is also stored in the flight planning computer. Some examples include reserve fuel requirements, weight and balance information, alternate and diversion stations, irregular operations information and more.

The process of building and producing the flight plan begins in Load Planning and Flight Dispatch. Load planners determine the weight and distribution of passengers, cargo and fuel. In the planning stages this is based upon historical and forecast information and transmitted to dispatch for their use in constructing the initial flight plan. An aerodynamic characteristic of the turbojet airplane is that the further aft the airplane's center of gravity, the less burnout fuel required. An aft center of gravity reduces the load on the horizontal tail which in turn reduces drag and fuel consumption.

Ideally, the airline would minimize fuel consumption by loading the airplane such that its center of gravity were exactly at the certified rear limit. However, for operational simplicity the airline imposes its own aft limit which is more restrictive than the certified limit. This practice permits, among other things, random passenger seat selection. Slightly forward of this operational limit is a "target" toward which the load planner attempts to locate the center of gravity. Loading to the exact aft operational limit is not attempted to avoid the possibility of exceeding the limit should unplanned payload arrive close to departure time. If the last minute payload caused the aft limit to be exceeded, cargo would have to be redistributed and a possible delay could result. When load planning is finished, the weight manifest is completed and the information is transmitted to Dispatch. Basic information includes airplane zero fuel weight, fuel on board, take-off weight, and C.G. location as a function of % MAC.

As Dispatch receives the load planning information, they begin to build the flight plan. This is often begun, for good reasons, several hours before the actual flight departs. When the flight crew reports to Dispatch an hour before departure, they review current conditions. The weather is reviewed and particularly the winds aloft to assure the winds on the flight plan match existing conditions. If requested, winds and temperature over other routes, can be included in the flight papers. Fuel loads are reviewed as they are sometimes planned conservatively to avoid last minute fueling and potential delays. If alternate airports are named, they are reconsidered as appropriate for current weather. Given the updated information, a route is determined and the final flight plan to be used is calculated.

The route selected depends upon segment length. For segments of less than 800NM, United and the FAA negotiate routes which are referred to as center stored. These routes are stored in the appropriate ATC center for all scheduled flights over that particular segment with standing ATC approval for use. Because only one route is stored for each segment, other route/wind combinations are not routinely evaluated for lesser fuel burn. Of course, on an individual basis, the operator can identify and ask for another route if it appears more desirable. The planned cruise altitudes which are stored with these routes are generally optimized for fuel burn. For segments exceeding 800NM, the operator requests a route on a trip by trip basis from a selection of as many as 20 routes. This permits optimization of route, wind and altitude. For these longer segments the route/wind combination offering the minimum wind distance is selected. This is done using the forecast weather data and selecting the route providing the minimum nautical ground miles for the true airspeed of the planned flight. It may be a somewhat crude method, but is quite fast and nearly always selects the optimum route.

Actual flight plan computation begins with the landing weight at the destination because this is the only known constant until the burnout is calculated. The airplane empty weight, payload, reserve fuels and taxi in fuels comprise the landing weight. Taxi fuels are established using historical data and vary with station, season and time of day. The airplane empty weight consists of the actual empty airplane weight plus cockpit and cabin crew and all passenger amenities. Fuel reserves include the minimum FAR reserve, contingency fuel reserve and holding and ferry fuel when necessary. In the past the FAR reserve was a fixed value based conservatively upon the heaviest possible airplane weight. We have refined this and now use a weight based upon actual planned weight plus a small margin to avoid last minute fueling should payload be greater than anticipated. We believe, incidentally, that this refinement has saved considerable amounts of fuel by carrying less, but still conservative fuel reserves. Estimate of savings indicate about 2 million gallons per year or the equivalent of 1200 typical 727 flights. The lack of truly accurate payloads have caused some concern in the flight planning process. Nearly 80% of actual payloads are less than planned. That is, the airplane is fueled for a greater weight than what is actually flown. The problem, however, is that the airplane must be fueled at some reasonable time before departure while recognition of a payload reduction usually occurs within the last ten minutes of departure.

Given the landing weight and route to fly the computer begins to fly the airplane backward from destination to origin adding burnout fuel as it goes. During this process, the airplane is generally flown at the highest altitude possible. Generally, for our fleets the most efficient altitude is very near the airplane's maximum altitude capability. However, with the introduction into our fleet of the latest 727's, we found that the more powerful engines are capable of climbing the airplane above its most economical altitude. This has now been modified so the program selects either the maximum or optimum altitude, whichever is most efficient for the prevailing winds. Step climbs are, of course, included in this logic. Airplane performance data is blended with the weather information in 50 nautical mile increments backwards until the departure station is reached. At this point, takeoff weight and trip fuel burnout are known. Now the flight plan is formatted and produced as shown. This entire computation requires an average of about six seconds per plan. A number of plans are calculated for various altitude and airspeed combinations. Then a single plan is selected in accordance with corporate policy. This policy will require some explanation as it encompasses more than fuel conservation.

In the flight planning process fuel conservation is a sensitive trade-off between time and fuel. Because many fuel

conservation practices slow the airplane down, some constraints must be applied to insure integrity of the airline's schedule. This time constraint is employed by using what we call a "target time". This is an "off" to "on" time computed for each segment based upon historical, seasonal, wind information and a policy of standard climb, cruise and descent speeds for the particular airplane type. The first flight plan calculated for an actual trip uses standard climb, cruise and descent speeds at the forecast conditions. The resulting flight time is compared to the previously established "target time". If the computed flight time is equal to or greater than the "target time", this is the plan to be used. If, however, the actual time is less than the "target time", a reduced cruise speed is selected which, of course, reduces fuel consumption and a new flight plan is produced. This process continues until a slower speed is reached at which the "target time" and actual time are equal, or until a minimum speed of long range cruise is reached. The effect is to save fuel when time permits. This time constraint is important to Flight Operations because Flight Operations is held accountable for block to block or "operating" performance. So sensitive to time is the operating performance, that a one minute increase in flight time across the operation can cause a 2-3% increase in late arrivals which corresponds to 20-30 arrivals per day. On the other hand, however, Flight Operations also pays the annual fuel bill, so the policy just described attempts to compromise these conflicting priorities.

Some steps have been taken to save fuel by slowing up. Along with many other carriers, we have reduced our policy climb and descent speed in the past few months. Previously standard climb and descent speeds were generally flown at about 340 knots above 10,000 feet. As we became more knowledgeable about minimum fuel climb and descents, these speeds were reduced to 300 knots for climb and 280 knots for descent. Although true optimum speeds will be slightly slower and are affected by other factors such as airplane weight and air temperature, these speeds generally are close to optimum and are a good compromise for standardization purposes. We have estimated that these reduced speeds have the potential of saving United Airlines in the neighborhood of 4 million gallons annually, which is the equivalent of 15 days of 727 flying. As discussed, flight plan cruise speed selection has been set by company policy. Minimum cruise speed is long range cruise which represents 99% of maximum fuel mileage. The speed associated with maximum fuel mileage is not used because of the considerably greater exposure of atmospheric disturbance causing the airplane to deviate from its selected speed. Constant throttle adjustments to retain speed could actually use more fuel than the 1% sacrificed for better stability. Opportunities to save large amounts of fuel at long range cruise are limited because, for most fleets, standard policy speeds are very close to long range cruise.

The data provided on the flight plan should be useful in conducting and monitoring flight progress and also, preferably, helpful in replanning enroute if necessary. Looking from left to right at a 727 flight plan, the first value is planned off to on time followed immediately by scheduled target-time. Notice that planned time is greater than target time, so this would be the plan used. The next value is the burnout (14,700 lbs.) from lift-off to touchdown. All fuel values are to the nearest 100 pounds. Next is FAR required reserve (5400 lbs.), followed by a contingency reserve (5300 lbs.) and, lastly, reserve fuel to alternate O'Hare (2800 lbs.). The first value on the next line is the route mileage in nautical miles. Then appears the planned takeoff weight (135,000 lbs) followed by estimated maximum allowable takeoff weight (154,400 lbs.). Next planned landing weight (121,300 lbs.) and maximum landing weight (142,500 lbs.). Next comes deviation from standard temperature in climb (+7°C), average wind component used to compute climb (13 kt. tailwind), zero fuel weight (107,800 lbs.), departure station (Denver), and finally cleared fuel load (28,200 lbs.). Now comes the body of the plan or the data associated with each fix along the route. The first item is the fix (O'Neal), then the mileage to the next fix (173NM) flight level at the fix (37,000 ft.), Mach number (.80), deviation from standard temperature (+6°C), true airspeed (463 kts.), wind direction and speed (280° at 66 kts. tailwind), wind component along the actual route (55 kt. tailwind), ground speed (518 kts.), time to next fix (20 minutes), burnout to next fix (2400 lbs.), and lastly fuel remaining on board (20,300 lbs.). A typical 1000 NM plan would include about five or six of these fixes. The last fix on the plan is that at the destination (Milwaukee) and shows descent distance (101NM), wind vector (240° at 23 kts.) and the wind component (17 kts.) used to calculate descent distance and segment fuel.

In the cockpit the flight plan is only as good as the forecast information. When the "real world" deviates from the forecast, the cockpit should have enough information to remain flexible and opportunistic towards saving fuel. Techniques and information to optimize fuel consumption enroute are provided in the flight plan and flight handbook. For example, using the true airspeed shown on the flight plan can save fuel under certain conditions. If enroute temperatures are hotter than planned, flying the true airspeed on the plan rather than Mach number, will slightly reduce actual speed back toward long range cruise, but retain the flight plan schedule integrity. Similarly, if, for whatever reason, one is forced to fly at an altitude lower than planned, flying the true airspeed associated with the planned altitude will slow the airplane up slightly again saving fuel while meeting planned flight time. Should ATC restrictions or other than planned enroute weather require an altitude change, appropriate information to replan is provided. Shown on the flight plan are forecast winds and temperatures for

altitudes other than those planned. In the flight handbook a wind/altitude trade-off chart is provided which permits the pilot to ascertain his ground nautical miles at various altitudes. With these pieces of information other altitudes and associated winds can be evaluated in terms of fuel efficiency. Also under consideration is whether to provide a speed/time trade-off chart. This would permit the cockpit to determine how much they could slow up when ahead of time. Such information has to be employed very carefully because history tells us that 20% of our operations initially planned to arrive 10 minutes early actually arrive late. If not carefully used, speed/time tradeoff information could adversely affect block to block performance.

The descent, in particular, offers a considerable fuel saving opportunity. If an unrestricted descent can be obtained, the ideal, optimum fuel descent is at idle throttle in a clean configuration down to the final approach. That is, throttles would be closed in cruise, and the descent would be made without advancing throttles or deploying spoilers, flaps, or landing gear until it is necessary to begin transitioning to the landing configuration. The problem appears straight forward until one recognizes that speed, wind, aircraft weight, and to a slight degree, temperature, all affect this profile. Errors in determining the initial descent point can be very fuel costly. Consider a typical descent distance of slightly over 100NM. A 10% error in determining where to start down would be about 10NM. If a DC-10 starts down 10NM too early, a fuel penalty of over 200 lbs. of additional fuel would be incurred. To our DC-10 operations this amounts to 2½ million gallons per year. On the other hand, if the airplane starts down too late, drag devices must be deployed to increase rate of descent so that the bottom of descent can be reached in fewer miles. This means, of course, that the airplane remained in cruise too long at cruise thrust when it could have been in descent at idle thrust. To assist the pilot in better determining his point of descent and monitoring descent progress, information is provided in the cockpit and on the flight plan which show for each altitude descent mileage at a given airplane weight with corrections for the wind encountered during descent. Additionally, we are searching for a better source of forecast descent winds for the flight plan. Because winds now used are from the last enroute fix which could be a considerable distance from the actual descent. It would appear there are considerable opportunities for improvement in this area.

Overwater flight planning is somewhat more complex due to two additional considerations. Federal Air Regulations require that should the airplane sustain a double-engine failure at the most critical point enroute, it must be capable of reaching a suitable airport at which to land. Because the airplanes may not be able to maintain a normal flight, the flight plan is no

longer valid. Therefore, given the conditions from the critical point on to the landing airport or a return to origin, a fuel burnout based upon a double-engine failure is calculated. On the DC-10 this burnout often exceeds the normal all-engine burnout on the original flight plan from origin to destination. Consequently, additional fuel is often added to overwater DC-10 flight plans. The other overwater consideration catered to is the possibility of a cabin depressurization at the most critical point. This would require an immediate descent to a lower altitude which is between 10 and 14 thousand feet. The airplane is then assumed to continue to destination or return to origin at these lower but high fuel consumption altitudes. Again, fuel is often added to overwater flights to meet this requirement. These calculations are made when the flight plan is being developed, and pertinent information for cockpit use should these emergencies occur is provided in the flight plan. This includes information such as distance to destination or origin, fuel required and fuel on board at the most critical point, and whether fuel dumping is a consideration.

Federal Air Regulations fuel reserves for destinations outside the contiguous United States are calculated differently than the domestic reserves. A portion of these reserves are based upon enroute flight time. The longer the flight, the larger the reserve fuel requirements. As a means of reducing very high reserve requirements and the high cost to carry these reserves, a procedure called "re-clear" is employed. This procedure permits dispatch of the airplane to a suitable reclear airport along the route but short of the intended destination. Fuel reserve requirements are then based upon the time necessary to fly to this closer point. When the reclear airport is reached, if fuel onboard is sufficient to continue on to the destination, the airplane is legally "re-cleared" to that destination at forecast conditions; however, if due to conditions other than forecast, the airplane does not have adequate fuel, it lands at the reclear airport to add fuel.

These operations are limited and initially planned very conservatively for obvious reasons. Unscheduled stops incur landing fees, flight crew pay, passenger inconvenience and other undesirable elements. Therefore, until operational experience is gained, very conservative reserve contingency fuel is carried to assure that fuel at the reclear airport is adequate to continue.

We currently employ a slightly different form of reclear on our southern routes to Honolulu. As previously mentioned, normal reserves and burnout are sometimes not adequate to permit continuation of a flight to its destination with the double engine failure or depressurization at the critical point. If this is the case, we compute fuel reserves based upon the

critical point between the West Coast and Hilo with the decision being made to divert to Hilo if either of these emergencies occur. Since Hilo would be closer than Honolulu, this would be the operationally prudent course of action anyway.

When it comes right down to it, the big fuel conservation opportunities have already been implemented. However, we do continue to chip away as best possible. Until sophisticated on-board Flight Management Systems become available on the majority of commercial airlines, a good share of the burden of fuel conservation will remain in the control of the flight crew. Therefore, information for fuel management in the cockpit must be accurate, credible and usable. Usability can't be over-emphasized. If it cannot be used in the operational environment, there is no need to provide it. It reminds me of an attempt we made several years ago in which we installed a specific range meter in a DC-10 for evaluation. Flight crews were asked to comment, but no guidance was provided as to how to use it. As a consequence, it flew around the skies three years without comment and totally ignored. As the information provided the flight crew in dispatch is of necessity forecast data, the cockpit needs the tools to respond in the most safe and fuel efficient manner to replan and reoptimize when conditions warrant. Flight Management Systems now being developed will, of course, have the ability to reoptimize in real time when they enter service. However, smaller airplanes such as 737's will probably not be able to justify the cost of these systems, making it necessary to rely upon the cockpit to implement fuel conservation to their best ability. During the past two years the Flight Planning System has come under intense scrutiny as fuel conservation becomes so increasingly important. We have recognized many shortcomings in our present system, and an effort is currently underway to provide an improved system when new computers with increased capacity become operational. The tremendous leverage the preparation and planning of flights have upon fuel conservation require the best system possible.

Fuel Conservation Techniques
in Jet Transport Aircraft Operations

H. H. Craven, Jr.
Captain-Northwest Airlines, Inc.

Introduction:

This paper examines in detail the operational procedures recommended by the aircraft manufacturers and suggests some reasonable alternatives when ATC or flight conditions make those procedures either impractical or impossible. Basic aerodynamic considerations are involved with emphasis on its effects on engine and aerodynamic efficiency. Included in the back pages of the paper are a density altitude chart with weight limitations for the B-747-1/7A Thrust aircraft, a fuel planning graph for the same airplane, some comparative power charts and computer run offs to help substantiate the information in the paper.

Although the principles involved in this paper apply to any aircraft, all performance specifications will be in reference to the Boeing 747-1.

Engine Efficiency:

This is the one area over which the flight crew has the least control. The effects of jet engine deterioration on fuel economy are well known; however, it is important in that engine efficiency is an index to the overall performance of any given flight. It has been well established that jet engines operate more economically in the higher flight levels, but there has been a tendency among some flight crews to consider only this one area and disregard those other elements that compose the overall performance of the aircraft.

Aerodynamic Efficiency:

It is important to fuel economy that an aircraft be operated in harmony with its environment. If an aircraft is taken to its maximum flight level, at its maximum gross weight and minimum temperature for that flight level, a negative fuel score is certain to result. A look at the density altitude chart will show why; at a pressure altitude of 31000 ft. with a SAT of -30 indicates a density altitude of 33000 ft. At a gross weight of 700,000 lbs. or under, the flight will operate there, but with a tremendous fuel penalty. Refer to the computer run on the next page and it can be seen on Line 80 that the effective MPT drops from 17.37 @ -7.1 TAT(-37.1 SAT) to 16.55 @

Aerodynamic Efficiency: (Continued)

-1.4 TAT (-31.4 SAT), a loss of 0.82 MPT. Should anyone wonder what an MPT loss figures in pounds of fuel, a final fuel score of -2.0 on Seattle to Tokyo flight would result in a fuel discrepancy of approximately 25,000 lbs.

If a flight crew were to encounter these conditions, what will be the alternative? A look at the next computer run for FL 290 will show that at a temperature of +4.1 TAT or -26.1 SAT the MPT is 17.11, a gain of .56 MPT over the equivalent temperature at FL 310. Considering further that the TAS for FL 290 is 514 kts versus 486 kts at FL 310 and the flight crew is presented with a viable alternative to running short of fuel, if the flight is operating in a headwind condition, then the logic of operating at FL 290 until down to a more reasonable weight becomes more apparent.

$L = \text{Coefficient/lift} \times \frac{1}{2} \text{ Air Density} \times \text{Area} \times \text{Velocity}^2$. This is the basic Lift equation. In this equation, the coefficient of lift increases with angle of attack until boundary layer separation occurs ahead of the camber resulting in a stall. The two variables available to maintain this maximum lift/minimum drag ratio are air density and airspeed. The aircraft manufacturer's fuel tables are set up on this basis, varying air density (step climb) for Normal cruise-constant Mach and varying (reducing airspeed for Long range cruise at a fixed altitude). Too high a Mach for a fixed altitude and gross weight will result in a lower angle of attack, a thickening of the boundary layer at the trailing edge of the wing creating drag as a squared function of the air-flow over the wing. At approximately Mach .91 on most subsonic aircraft, Mach buffet will occur. If the flight crew in the FL 290/310 example had further reduced their true air speed to 500 kts at FL 290 they could have effected a further fuel savings by operating in a lower drag range. If the flight crew is operating in a tailwind condition, climbing over weather or preserving an assigned altitude, then this enlists an entirely different set of circumstances and becomes a judgment call on the Captain.

Climb and Descent Profile:

This should not be confused with the Profile Descent used at some airports, but rather should be considered part of the altitude selection process. The normal climb schedule for a B-747-1 on a Seattle to Tokyo flight would be FL 310, 350 and 390, although it is possible to get FL 330 and 370 from ATC for Westbound flights. Assuming a take off gross weight of 710,000 and a fuel burn off of 240,000 lbs, the landing gross weight would be 470,000 lbs. The optimum weight for FL 390 is 515,000 lbs. Climb fuel for a 4000' climb from FL 350 to FL 390 is 800 lbs.; 4000 lbs. of fuel is reserved for descent and landing, placing the descent weight at 474,000 lbs. The difference in fuel consumption between FL 350 and 390 for the weight brackets between 520.0 and 480.0 is 800 lbs. or the same as the fuel expended for climb. Assuming a 474,000 descent weight, this would only put the flight on the plus side at FL 390 for a fuel savings of 310 lbs. Assuming a headwind component the flight would only have to pick up one minute of time through the weight brackets of 520.0 to 474.0 (or 2 hours flight time) to equalize the fuel savings at FL 390.

It may seem on the surface that this paper advocates low altitude operations. Not so! What is advocated is that all conditions be analyzed for the best course of action by the flight crew. The best computer flight plan can break down as can the best meteorological forecast, and the only persons who can decide the best course of action is the operational crew with an able assist from the dispatcher. Fuel conservation takes a lot of hard work, and fatigue takes its toll on efficiency, but it can be done with training and the materials to work with.

Conclusion:

Space and time allocated for this paper do not permit the formulae, equations and details necessary to cover all aspects or possibilities of fuel conservation. It could never be done in any case, but there are a few suggestions for immediate relief from excessive fuel consumption and its related expense:

Conclusion: (Continued)

1.) Operators of jet aircraft could conduct periodic refresher training in fuel conservation techniques. It will serve two purposes: give the flight crews the information to work with, and keep them continually aware of the necessity of fuel conservation.

2.) Improved inflight communications, particularly on international flights. It is essential if any degree of fuel integrity is to be maintained that affected flights be advised of changes in weather patterns as they occur.

3.) Improved operational tables. The computer run on page 2A has a suggested format; further Long range cruise tables containing the same information should be located directly below Normal cruise tables so that crews have an immediate reference for comparison.

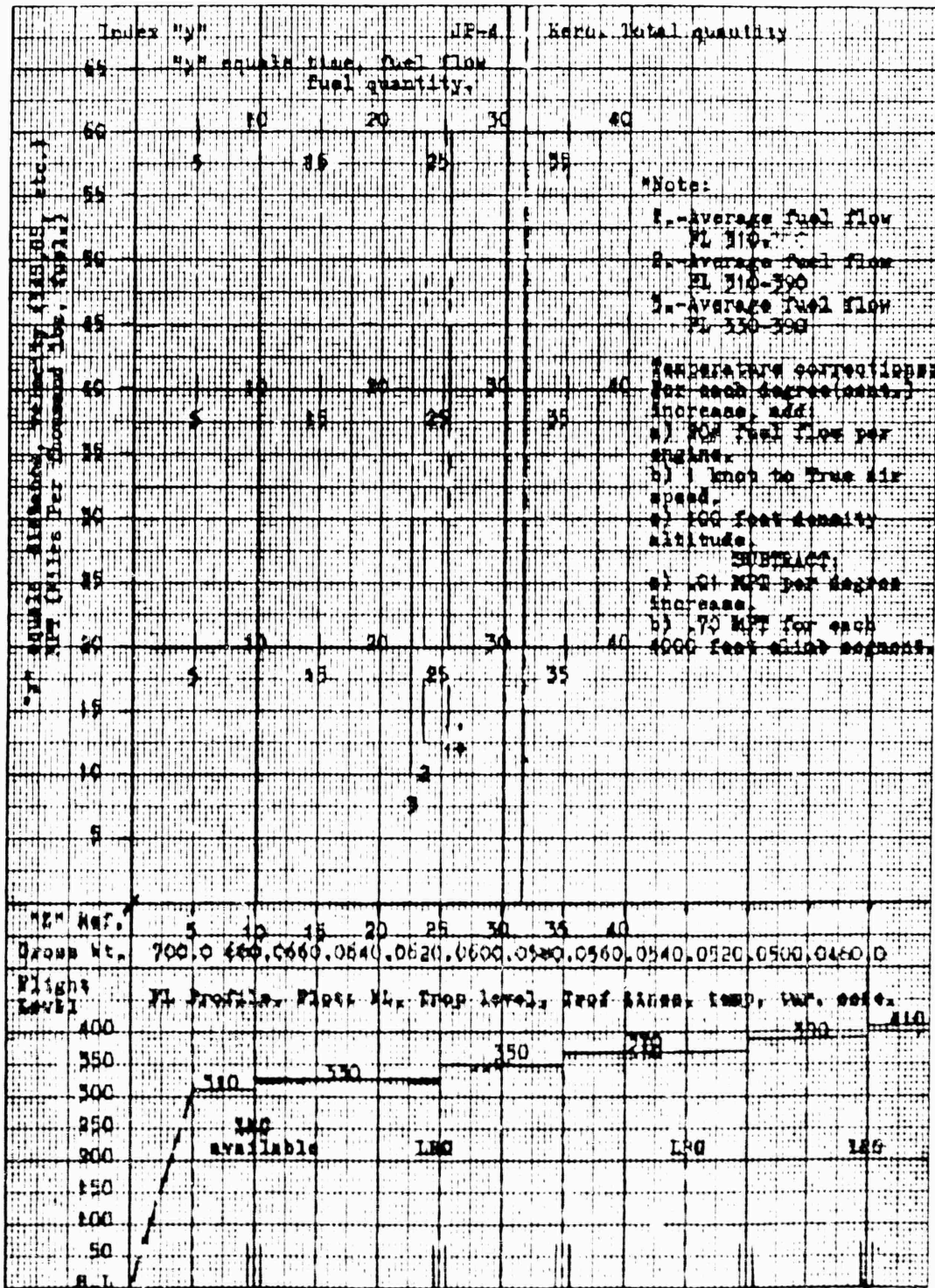

TEMPERATURE-DENSITY ALTITUDE GRAPH

Copyright 1981 by H.H. Craven Jr.

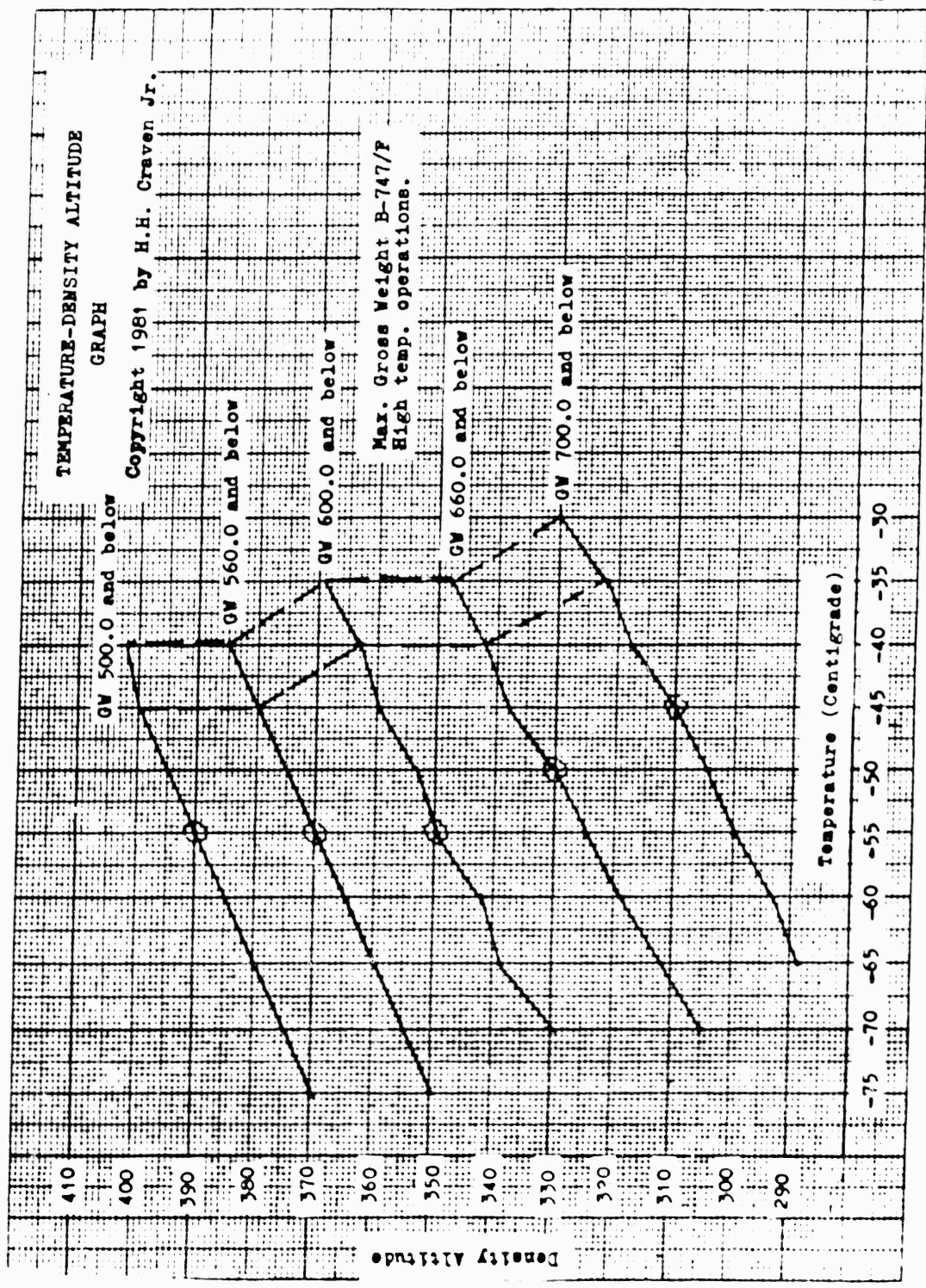

Max. Gross Weight B-747/P
High temp. operations.

COPYRIGHT 1981 BY H.H. CRAVEN JR.

```

10 PRINT "FUEL DATA 747-1/7A, GW 700.0-680.0, FL 290 S/T -42.5"
20 PRINT "TAT -30.1, -24.4, -18.7, -13.0, - 7.3, - 1.6, + 4.1 "
30 PRINT "SAT -60.1, -54.4, -48.7, -43.0, -37.3, -31.6, -26.1 "
40 PRINT "IAS 330, 330, 330, 330, 330, 330, 330 "
50 PRINT "TAS 477, 483, 487, 492, 502, 508, 514 "
60 PRINT " FF 6880, 6990, 7090, 7200, 7300, 7410, 7510 "
70 PRINT "TFF 27520, 27960, 28360, 28800, 29200, 29640, 30040 "
80 PRINT "MPT 17.33, 17.27, 17.17, 17.08, 17.19, 17.14, 17.11 "
90 PRINT "D/A 26900, 27300, 28200, 29000, 29700, 30000, 30900 "
100 PRINT "NAHA FL 310"
110 PRINT "GSDR +6, +7, +9, +9, +6, +7, -17 "
120 PRINT "FL 330 AV @ GW 680.0/-37.1"
130 PRINT "400 LBS FUEL, -.26MPT/2000' CL."
140 PRINT "SEE LRC TABLES/MAX. END."

```

```

10 PRINT "FUEL DATA 747-1/7A, GW 700.0, FL310 S/T -46.3"
20 PRINT "TAT -35.6, -29.9, -24.2, -18.5, -12.8, - 7.1, - 1.4"
30 PRINT "SAT -65.6, -59.9, -54.2, -48.5, -42.8, -37.1, -31.4"
40 PRINT "IAS 314, 314, 314, 314, 314, 314, 314 "
50 PRINT "TAS 471, 477, 484, 489, 496, 503, 486 "
60 PRINT " FF 6710, 6810, 6920, 7030, 7130, 7240, 7340"
70 PRINT "TFF 26840, 27240, 27680, 28120, 28520, 28960, 29360"
80 PRINT "MPT 17.55, 17.51, 17.49, 17.39, 17.39, 17.37, 16.55"
90 PRINT "D/A 28900, 29350, 30000, 30600, 31300, 32000, 32750"
100 PRINT "OAA FL 290 AND BELOW"
110 PRINT "GSDR -6, -7, -9, -9, -6, -7, +17 "
120 PRINT "FL 330 AV @ 680.0 -37.1, OPT GW 660.0."
130 PRINT "400 LBS. FUEL -.26 MPT/2000' CL."
140 PRINT "SEE LRC TABLES/MAX END."

```

- | | |
|------------------------|---|
| * 20 True air temp. | 80 Nautical miles per thousand lbs/fuel |
| 30 Static air temp | 90 Density altitude |
| 40 Indicated air speed | 100 Other altitudes available |
| 50 True air speed | 110 Ground speed differential required |
| 60 Fuel flow/engine | at lower/higher altitude (from TAS). |
| 70 Total fuel flow | Divide by altitude differential for |
| | wind shear requirement for zero ch- |
| | ange in fuel score at affected FLs. |

COMPOSITE TAS AND FUEL TABLES
FL 350 and FL 390

TRUE AIRSPEED SCHEDULE - NORMAL CRUISE

TAS 35,000 FEET PRESSURE ALTITUDE								TAS 39,000 FEET PRESSURE ALTITUDE									
AMBIENT TEMP °C								AMBIENT TEMP °C									
WGT	-70	-65	-60	-55	-50	-45	-40	-35	WGT	-75	-70	-65	-60	-55	-50	-45	-40
620	466	472	477	483	488	494	490		520	460	466	472	477	483	488	492	
600							499	489	500							494	498
580								505	480								499
560									460								
540									440								
520									420								
500																	
480																	
460																	
440																	
420																	

NORMAL CRUISE OPERATING TABLES

35000 FT P.A. STO TEMP -54.2					
GW	TAT	IAS	EPR	LIMIT	FF
520	-41.3	288	1.30	1.49	5060
	-35.6	288	1.30	1.49	5140
	-29.9	288	1.30	1.49	5220
TO	-24.2	288	1.30	1.49	5300
	-18.5	288	1.30	1.49	5380
	-12.8	288	1.30	1.49	5460
500	-7.1	288	1.30	1.47	5540
	-41.3	288	1.28	1.49	4940
	-35.6	288	1.28	1.49	5020
TO	-29.9	288	1.28	1.49	5110
	-24.2	288	1.28	1.49	5190
	-18.5	288	1.28	1.49	5200
480	-12.8	288	1.28	1.49	5340
	-7.1	288	1.28	1.47	5420
	-41.3	288	1.26	1.49	4840
480	-35.6	288	1.26	1.49	4920
	-29.9	288	1.26	1.49	5000
	-24.2	288	1.26	1.49	5080
TO	-18.5	288	1.26	1.49	5160
	-12.8	288	1.26	1.49	5230
	-7.1	288	1.26	1.47	5310
460	-41.3	288	1.24	1.49	4720
	-35.6	288	1.24	1.49	4800
	-29.9	288	1.24	1.49	4880
TO	-24.2	288	1.24	1.49	4960
	-18.5	288	1.24	1.49	5030
	-12.8	288	1.24	1.49	5110
440	-7.1	288	1.24	1.47	5180

39000 FT P.A. STO TEMP -50.5					
GW	TAT	IAS	EPR	LIMIT	FF
520	-47.0	262	1.44	1.49	4880
	-41.3	262	1.44	1.49	4960
	-35.6	262	1.44	1.49	5040
TO	-29.9	262	1.44	1.49	5120
	-24.2	262	1.44	1.49	5200
	-18.5	262	1.44	1.49	5280
500	-12.8	262	1.44	1.49	5360
	-47.0	262	1.40	1.49	4680
	-41.3	262	1.40	1.49	4760
TO	-35.6	262	1.40	1.49	4840
	-29.9	262	1.40	1.49	4920
	-24.2	262	1.40	1.49	5000
480	-18.5	262	1.40	1.49	5070
	-12.8	262	1.40	1.49	5150
	-47.0	262	1.37	1.49	4520
480	-41.3	262	1.37	1.49	4600
	-35.6	262	1.37	1.49	4680
	-29.9	262	1.37	1.49	4750
TO	-24.2	262	1.37	1.49	4830
	-18.5	262	1.37	1.49	4900
	-12.8	262	1.37	1.49	4970
460	-47.0	262	1.34	1.49	4360
	-41.3	262	1.34	1.49	4440
	-35.6	262	1.34	1.49	4510
TO	-29.9	262	1.34	1.49	4580
	-24.2	262	1.34	1.49	4650
	-18.5	262	1.34	1.49	4720
440	-12.8	262	1.34	1.49	4800

AIR TRAFFIC CONTROL
ITS EFFECT ON FUEL CONSERVATION

EDWIN H. PRICE
SPECIALIST-AIR TRAFFIC SYSTEMS
EASTERN AIRLINES, INC.

PRECEDING PAGE BLANK-NOT FILMED

In 1980, air traffic delays cost Eastern Airlines over 95,000,000 gallons of wasted fuel and over \$150,000,000 in direct operating expenses. That means that delays cost the airline industry some 1,000,000,000 gallons of wasted fuel. The most productive way to reduce this huge waste of fuel is to develop a more efficient ATC system, one that will minimize delays and still provide for reasonable growth in air traffic.

Some say that delays have increased because traffic has increased. It is quite true that traffic has increased because more people choose to travel by air. The airlines have responded to this growth in air travel by providing additional service in the market place. Smaller airplanes have been replaced with larger equipment and seating capacity has been increased in most aircraft. For example, the 107-seat Air-Shuttle airplane has been replaced with a new Boeing 727 with 177 seats. The FAA must also increase system capacity to keep pace with this demand.

Positive action must be taken to resolve this problem. There are two ways to do this. We can take immediate steps to increase capacity and reduce delays or we can make a five-year study to find an answer. Either course would correct the problem--but in different ways. If we wait five years for a solution, the problem will have disappeared because large numbers of aircraft will be parked, permanently.

The importance of fuel conservation has rapidly increased since the beginning of the fuel crisis in 1973. At that time, jet fuel cost 12 cents per gallon and represented about ten percent of the airlines direct operating expense. Today, the same jet fuel costs approximately one dollar per gallon and represents some thirty percent of the direct operating expense.

In recognition of this crisis situation, the FAA implemented a number of programs to help the users save fuel. The list includes:

- Local flow traffic management
- Pilot discretion descents
- More frequent approval of direct routes
- More frequent approval of requested altitudes
- Unrestricted climb to altitude

These procedures allow aircraft to remain higher, longer, at the more fuel efficient altitudes. They also reduce flight time below 10,000 feet where the 250 knot speed rule applies, and they allow arriving aircraft to maintain at least 210 knots, for as long as possible, to keep the aircraft in a fuel efficient configuration. Most commercial turbojets require the extension of slats or flaps below 200 knots and this increases fuel flow by as much as 30 percent.

Other FAA procedures include:

- Fuel Advisory Departure Procedures (FAD)
- Expanded Quota Flow
- Severe Weather Avoidance Plan (SWAP)
- Gate hold procedures

These procedures are designed to meter traffic so that the arrival demand equals airport acceptance rate. This is done by holding aircraft on the ground at the departure airport. When delays are unavoidable, most everyone would agree that they should be absorbed on the ground to conserve fuel, but I think we can reduce the unavoidable delays by increasing efficiency and capacity. The theory today seems to be that if the aircraft is at the gate it will not burn any fuel and it certainly will not create an ATC problem. The time has come to revitalize the ATC system so that it can handle more aircraft, more efficiently rather than meter the traffic to fit an obsolete system that was designed some 25 years ago.

Since the onset of the fuel crisis in 1973, users of the system have initiated many of their own fuel saving programs including:

- Computerized flight planning to determine best route and altitude.
- Reduced operating speeds during climb, cruise, and descent.
- Area Navigation Systems for better route selection.
- Aerodynamic cleanliness to reduce drag.
- Carry less reserve fuel.
- Taxi on less than all engines.
- New fuel efficient aircraft.
- And in some areas, reduce flight schedules.

The success of the FAA procedures and many of the user programs is largely dependent upon the air traffic controllers. Controller efficiency and technique are very important factors and the FAA should place special emphasis on maximizing controller production and proficiency. Some controllers are still doing "business as usual" with very little initiative or flexibility in their control actions, while the others willingly accept the challenge and spirit of fuel conservation and apply their individual techniques. We are very grateful for these dedicated controllers because they have made a significant contribution to energy conservation. Historically, controllers have been charged with the responsibility for the safe and expeditious movement of aircraft. In the early 1960's one FAA administrator brought noise abatement into prominence by stating that "noise abatement is second only to safety." That philosophy has served its intended purpose more than adequately. In today's environment, it would make more sense to say, "fuel conservation is second only to safety." Noise abatement can be accomplished in other ways without wasting fuel.

In spite of all these many good things that have been done by FAA and the users, air traffic delays still cost us millions of gallons of fuel each year. Now the obvious question is, what else can be done to reverse the trend of these ever increasing delays?

First, we must realize that we are all together in this battle to save energy. We sink or swim together. If the airlines and other aviation groups grow and prosper, the controller workforce will also grow and prosper. If there are severe cutbacks in flight operations, you can be assured there will be similar reductions in the number of controllers required. If anyone doubts that this is a serious problem, a quick look at the 1980 financial reports of the airline industry should be very convincing.

Now, let's discuss airport capacity--the number of landings and takeoffs that can be accommodated. The acceptance rate at the major airports is without doubt the greatest constraint on system capacity. Given the existing environmental constraints, it's unlikely that any new major airports will be constructed in the foreseeable future. Therefore, we must achieve greater capacity and efficiency from existing runways. There are many factors that influence airport capacity. Runway and taxiway configuration is probably the most important. Controllers should use the most productive combination of runways whenever wind conditions permit. There must be an adequate number of properly located high-speed turnoffs to minimize runway occupancy time. Improved methods must be found to better utilize closely spaced parallel runways.

The microwave landing system has a great potential for increasing runway utilization. Its unique capabilities could lead to more fuel efficient noise abatement procedures. Simultaneous precision approaches could be established on parallel runways with reduced lateral separation. Non-interfering approaches and missed approaches would be possible at closely spaced airports such as the New York airport complex.

Metering and spacing techniques must be improved to assure that every available landing slot contains an aircraft. No holding upon arrival is a worthy goal, but there must be a sufficient reservoir of aircraft in the arrival stream to keep constant pressure on the system.

The mix of aircraft types and speeds also affects airport capacity. The greater the difference in final approach speeds the more difficult it is to get ideal landing intervals and maximum runway capacity. The problem is most serious at the major hubs where 80 to 90 percent of the aircraft are turbojets with a final approach speed in the 125 to 150 knot range. When a light airplane with an airspeed of 80 or 90 knots enters this stream of turbojets, there is an immediate and definite reduction in runway capacity. Increased separation due to wake turbulence is required between the light aircraft and the preceding turbojet and it is more difficult to sequence another faster aircraft behind the slower aircraft. In fact, this is one of the primary reasons for fuel wasting go-arounds.

Perhaps it's time to examine the logic and the fuel wasting implications of allowing light aircraft operations on the same runways used by large turbojet aircraft at the overcrowded major hubs. Using a 10,000 foot runway for a light aircraft is like using a ten-ton truck to haul 500 pounds of bricks just because the truck happens to be there. If fuel conservation is important, FAA's first-come first-served policy regardless of aircraft type is no longer a viable concept. As an alternative, let's provide independent short runways where possible at major airports and encourage noncommercial aircraft to use satellite airports. This would provide for a safer operation and increase airport capacity. Now the argument arises that since these large runways are built with tax money, anyone should be allowed to use them. Well, that's certainly a good argument, but what about those small airports also built with tax money. The large jet transport could not use those airports even if they wanted to. On November 5, 1980, the FAA Administrator announced that his agency had allocated \$111.1 million (that's your and my tax money) for 178 projects at 118 satellite airports in 57 metropo-

politan areas. The Administrator stated, and I quote, "The purpose of the program is to relieve the congestion and reduce the mix of commercial and noncommercial aircraft at major hub airports by making neighboring satellite fields more attractive to private and business fliers." This is the first serious effort of the FAA to improve the satellite airports and this program should proceed without delay.

Noise abatement procedures often limit the use of certain runways, thereby reducing airport capacity. Controllers should be allowed to use the most productive runways whenever the wind permits. In many locations this will require the creation of a better balance between fuel conservation and noise abatement. With the recent demise of the office of Noise Abatement and Control, this should be easier to achieve. Noise reduction is very important to airport neighbors, and it is in the best interest of the users to keep noise to a minimum. However, noise abatement procedures should be developed with a certain degree of reasonableness with consideration being given to the amount of fuel that would be wasted. Many of the aircraft in today's airline fleet meet or exceed the noise limitations set forth in FAR Part 36, but no consideration is given to these "quiet" aircraft when establishing noise abatement procedures. To some people, the mere sight of an aircraft automatically rings the noise monitor bell.

The enroute environment of the ATC system is completely outdated and needs major surgery. The jet route system, in which aircraft fly to or from a series of VORs, has been in use since the 1950s with only an occasional band-aid applied from time to time. This route structure is no longer efficient nor desirable for today's modern jet aircraft. Although many aircraft have area navigation equipment that enables them to fly direct routes for extended distances, they are often denied this opportunity due to limitations of the existing route structure and the lack of flexibility in the system. If we are going to win the fuel conservation battle, the ATC system must be restructured to accommodate parallel offset courses and random RNAV flights on a regular basis. In this way, more flights could operate at or near optimum altitudes.

The existing rule requiring two thousand feet vertical separation above FL 290 is another constraint on enroute system capacity. I'm not an expert on altimetry systems, but it is difficult for me to understand that 1000 feet vertical separation is safe at 29,000 feet but it is unsafe at 30,000 feet. It is generally agreed that most aircraft operating regularly above FL 290 have altimetry systems with sufficient accuracy and reliability to support 1000 feet separation, although some aircraft would not meet the required tolerances. Perhaps it's time to establish minimum altimetry standards that would permit 1000 feet vertical separation at these critical altitudes. Such a system is used very successfully on the North Atlantic Track system with regard to Minimum Navigation Performance Standards. It's very simple, if the aircraft does not meet the standards, it does not fly on the track system. Let me hasten to add that this is not a new idea. The ATA petitioned the FAA for rulemaking action to provide 1000 feet vertical separation up to FL 450 almost ten years ago, but it was denied. The fuel crisis demands that it be reevaluated.

Full utilization of special use airspace such as restricted and warning areas must become a way of life in the ATC system. These large areas set aside for military training and testing often add many miles to the flight path of an aircraft. These areas play an important role in military preparedness, but it is also important to make this airspace available to the public when it is not in use for military purposes. The warning areas off the east coast are a case in point. After many years of work, a Letter of Agreement between the military and the FAA was finally consummated in 1979. This agreement was designed to make it easy and simple for the military to release only a few altitudes in a narrow corridor for civil use. Two military controlling facilities have recently been established to coordinate scheduling activities and monitor the use of the warning areas. However, to my knowledge, this offshore route between New York to Wilmington, N. C. has never been made available to air traffic control in its entirety. Records indicate that the airspace was not in use on some occasions, but a breakdown in communication prevented its release. This offshore route was intended as an escape valve for traffic departing the New York area when normal southbound routes are impacted by thunderstorms or by traffic rerouted from other areas affected by weather.

This brings us to another FAA program which is often counterproductive, the Severe Weather Avoidance Program (SWAP). This procedure is implemented during the thunderstorm season when severe weather is blocking some of the arrival or departure routes. It has been used repeatedly in the New York area. Flights are often given lengthy off-course reroutes with little justification. Controllers often reroute traffic without having real time information on the location and intensity of thunderstorm activity. By the time the rerouted aircraft gets to the impacted area, the thunderstorm is no longer a factor. In addition, the procedure is usually implemented too soon and remains in effect too long.

Last, but certainly not least, are the constraints imposed by Letters of Agreement between adjacent Air Traffic Control Centers. In outlining ways to save fuel, a former Director of the FAA's Air Traffic Service admonished the controllers to separate airplanes from airplanes and not airplanes from airspace. Letters of Agreement are in complete discord with this advice because they do, in fact, separate airplanes from airspace. These Letters cause premature descents to fuel inefficient altitudes. A one-minute premature descent on every trip in 1980 would have cost Eastern Airlines over \$5,000,000 in wasted fuel. We all understand that canned ATC procedures are necessary during peak traffic periods, but in off peak periods, these procedures impose unnecessary rigidity on the system. Flexibility is a necessary ingredient in an efficient ATC system.

For the most part, these are near term improvements--things that can be done now with very little expense for manpower or equipment. These are not new ideas--they have been discussed many times. What we need now is action, not more discussion. When you combine these efforts with all the long term exotic programs FAA has promised us, I am optimistic that there will be a significant increase in system capacity and a significant reduction in wasted fuel. These long term FAA programs, if we ever get them, include:

politan areas. The Administrator stated, and I quote, "The purpose of the program is to relieve the congestion and reduce the mix of commercial and noncommercial aircraft at major hub airports by making neighboring satellite fields more attractive to private and business fliers." This is the first serious effort of the FAA to improve the satellite airports and this program should proceed without delay.

Noise abatement procedures often limit the use of certain runways, thereby reducing airport capacity. Controllers should be allowed to use the most productive runways whenever the wind permits. In many locations this will require the creation of a better balance between fuel conservation and noise abatement. With the recent demise of the office of Noise Abatement and Control, this should be easier to achieve. Noise reduction is very important to airport neighbors, and it is in the best interest of the users to keep noise to a minimum. However, noise abatement procedures should be developed with a certain degree of reasonableness with consideration being given to the amount of fuel that would be wasted. Many of the aircraft in today's airline fleet meet or exceed the noise limitations set forth in FAR Part 36, but no consideration is given to these "quiet" aircraft when establishing noise abatement procedures. To some people, the mere sight of an aircraft automatically rings the noise monitor bell.

The enroute environment of the ATC system is completely outdated and needs major surgery. The jet route system, in which aircraft fly to or from a series of VORs, has been in use since the 1950s with only an occasional band-aid applied from time to time. This route structure is no longer efficient nor desirable for today's modern jet aircraft. Although many aircraft have area navigation equipment that enables them to fly direct routes for extended distances, they are often denied this opportunity due to limitations of the existing route structure and the lack of flexibility in the system. If we are going to win the fuel conservation battle, the ATC system must be restructured to accommodate parallel offset courses and random RNAV flights on a regular basis. In this way, more flights could operate at or near optimum altitudes.

The existing rule requiring two thousand feet vertical separation above FL 290 is another constraint on enroute system capacity. I'm not an expert on altimetry systems, but it is difficult for me to understand that 1000 feet vertical separation is safe at 29,000 feet but it is unsafe at 30,000 feet. It is generally agreed that most aircraft operating regularly above FL 290 have altimetry systems with sufficient accuracy and reliability to support 1000 feet separation, although some aircraft would not meet the required tolerances. Perhaps it's time to establish minimum altimetry standards that would permit 1000 feet vertical separation at these critical altitudes. Such a system is used very successfully on the North Atlantic Track system with regard to Minimum Navigation Performance Standards. It's very simple, if the aircraft does not meet the standards, it does not fly on the track system. Let me hasten to add that this is not a new idea. The ATA petitioned the FAA for rulemaking action to provide 1000 feet vertical separation up to FL 450 almost ten years ago, but it was denied. The fuel crisis demands that it be reevaluated.

MLS - Microwave Landing System

DABS/Data Link- Discrete Address Beacon System

ATARS - Automated Traffic Advisory & Resolution Service

BCAS - Beacon Collision Avoidance System

This new generation of ATC equipment will assist the controller in making more accurate judgment decisions and relieve him of many time consuming chores. He can then devote more attention to making the system more efficient.

I urge the FAA to seriously consider these options and make every effort to develop a more efficient ATC system. It is my sincere belief that the air traffic controller will accept his part of this challenge and make an even greater contribution to fuel conservation.

Thank you for your attention.

FUEL CONSERVATION DURING DESCENT

Captain N. F. Anderson
Qantas Airlines

PRECEDING PAGE BLANK-NOT FILMED

FUEL CONSERVATION DURING DESCENT

We are all aware, that the manipulation of fuel costs and supplies has created an energy crisis in the aviation industry. Airline managements have responded to this crisis by ensuring that their flights are operated as efficiently as possible.

Publications on aviation fuel conservation, produced recently by aircraft manufacturers, clearly indicate that airline flight crews have a significant responsibility in the effective use of the fuel available.

In any flight operation, fuel conservation consists primarily of two considerations:

1. Uplifting the minimum fuel for the safe operation of the flight.
2. Operating the airplane efficiently to minimise fuel burn.

This is even more significant when we review our current operation of large fleets of wide bodied jets and consider the vast quantities of fuel used. 200-300 kg of fuel saved per flight can represent millions of dollars of fuel saved annually on a fleet wide basis.

Already significant savings have been effected by careful flight planning, reduction in surplus fuel uplifts by flight crews, reduction in route mileages and making the most effective use of the best economy speed schedules available. However, we have made very little progress in the descent phase of flight operations due to the number of variable factors confronting the pilot which prove difficult to monitor.

The flight operations performance manuals provide graphs and tables on descent figures but there is no practical way of implementing this theory. These manuals are impractical on the flight deck due to the time required to extract information from this type of presentation. Certainly, cross-checking the profile against the graphs at an intermediate stage on the descent is hardly contemplated in practice. As a result, descents are generally conservative, the aircraft is low and slow too early in the approach phase where most fuel is burnt.

A major international airline, writing on fuel conservation to the pilots through an "in-house" news magazine, had the following to say on fuel savings during descent:

"It is very difficult to tell when to start descent and you require experience before you can make a proper decision. Early initiation of descent will result in a longer manoeuvre at lower altitudes consequently burning additional fuel".

This, of course, is very true, but no solutions to the problem were proffered.

If we direct our attention specifically to the descent phase of flight, we must consider the effect of the external and internal environment in achieving minimum fuel usage.

The external environment is generally beyond the control of the pilot. We rely heavily on the continual liaison between aviation administrations at state and federal level in association with aviation agencies ICAO and IATA to streamline the following services:

1. Air Traffic Control (ATC) equipment to produce optimum capacity and performance.
2. Improved "Standard Arrivals" procedures to optimise routings and speeds.
3. Release of danger and prohibited areas when they are not in use.
4. Profile descent implementation as per ICAO and IATA recommendations.
5. Provide ATC structures to allow continuous descents from an approach or entry fix.
6. Ensure "track miles to touchdown" are available to pilots under radar control.
7. Provide visual approaches if they can be flown more efficiently.
8. Advise speed control in advance to allow the pilot flexibility in adjusting his descent profile.

Let us now consider the internal environment and some of the variables confronting the pilot in his evaluation of the descent distance required from cruise altitude.

He must consider:

Weight Variations from sector to sector. A heavy airplane requires a greater distance to glide due to the lower initial descent rate compared to a lighter airplane. The heavy airplane also has a higher inertia in the slow down segment of the descent which also requires a greater distance. The landing weight variations between similarly configured B747's can be as great as 80 tonnes or approximately 175,000 lbs. which can make a difference of thirteen nautical miles to the still air distance required.

Altitude variations from sector to sector, the higher the cruise altitude the greater the distance required to descend.

Head or tail wind component variations must be used to adjust the descent distance. The difference between a head wind of 50 kts. and a tail wind of 50 kts. is approximately 30 nms.

Distance Variations in terms of added miles to cover ATC approach sequences and radar vectors must be included.

Speed Variations must be considered and applied to the distance required to glide the airplane accurately. For instance, a slower speed requires a greater distance for descent.

When all of these variables are applied to assess the top of descent distance and the pilot has the capability of making intermediate corrections within a changing environment, then the optimum descent can be achieved.

Do the flight crews have the capability of assessing all the variables and making intermediate corrections to the profile to save fuel?

This is the question we asked ourselves in Qantas Flight Operations. This in turn led to a lengthy investigation into the actual fuel burn achieved on descents compared to the desired book optimum. This four month survey investigated every descent into airports throughout our world-wide network. Particular emphasis was given to airports, whose low density traffic or sophisticated ATC procedures, should have produced glide descents to final approach and therefore optimum fuel burn.

Honolulu, for example, uses a profile descent and we would consider our pilots capable of making a glide descent to the final approach fix. We would not expect this into San Francisco due to its ATC sequences, so the fuel burn appropriate to this airport would be dropped from our final analysis.

We have over 50% of our airports where we could expect a descent to come close to the optimum fuel figure yet our survey showed the predominance of conservative descents even at these favourable airports. A descent fuel burn figure of nearly double the book figure was the surprising and alarming result of the survey.

We had effected considerable fuel savings in the climb and cruise segments of our operations and it was now obvious that we had to resolve the problem of fuel wastage on the descent.

The complexity of the descent has largely been left to the ingenuity of the pilot and "Rules of thumb" abound. However, if one has the choice of being too high at the end of a descent or being conservatively low, then I am afraid the latter is more attractive to the pilot. The possibility of a "go-around", if one is caught high and fast, is too embarrassing to contemplate and although it happens frequently, it rarely happens to the same pilot twice. He reverts to the comfort of the low and slow approach and joins the swelling ranks of conservatives.

It is a fair statement to make that pilots invariably make conservative descents because the instrumentality to provide accurate descent guidance is not available to them.

An interesting paper I read recently stated: "The Federal Aviation Administration has developed an automated time-based metering form of air traffic control for terminal area arrivals. It is called the local flow management/profile descent. The concept provides fuel savings and increased flow rates by matching the airplane arrival flow to the airport acceptance rate. The radar controller maintains the time management of each airplane by speed control or path stretching with radar vectors. Pilot workload is very high since the pilot must plan for an idle thrust descent to arrive at the metering fix using various rules of thumb.

In the original operational concept of the time-based metering program, the flight crew was responsible for both the descent and time navigation to the metering fix. However, the pilot had little or no computed guidance to aid him with this highly constrained, four dimensional navigation problem. Flight crews were forced to rely on past experience and (here's that phrase again) various rules of thumb to plan descents. This practice resulted in unacceptably high cockpit workloads and the full potential of fuel savings from a planned descent was not obtained.

In an effort to reduce the flight deck workload, the responsibility of delivering the airplane to the metering fix, at an assigned time, was transferred to the A.T.C. controller. This operation resulted in airplane arrival time accuracy at the metering fix of between 1 and 2 minutes. Improved arrival time accuracy and resulting fuel savings could be obtained at the cost of a significant increase in the A.T.C. controller's workload.

Splitting the navigation responsibilities between the flight crew and ATC controller reduced the pilot's workload. However, when the ATC controller had to use speed control for time management purposes, the pilot was forced to deviate from his planned descent profile, consequently more than the minimum fuel was used.

The National Aeronautics and Space Administration (NASA) then developed and flight-tested a FLIGHT MANAGEMENT DESCENT ALGORITHM designed to improve the accuracy of delivering an airplane to a metering fix at a time designated by ATC. NASA used a computer in a specially configured B737 research airplane and collected data on 19 flight test runs to a metering fix. The standard arrival error was only 12 seconds with no greater error than 29 seconds." Ultimately, airborne and ground computers will solve the descent/approach problem as will sophisticated "Flight Management Systems" in the next generation of aircraft but what can we do today, now, to conserve this fuel wastage without expensive outlays on equipment.

There is a saying that "Necessity is the mother of invention". It would appear so as we come up with a multi-dimensional slide rule we called the "Climb/Descent Monitor" which has proved to be very cost effective.

The monitor was specifically designed to present to pilots a simple indication of the climb and descent parameters of the airplane's performance envelope. It enabled a pilot to make a quick assessment of the airplane performance for any combination of altitude, weight, speed and wind velocities.

If the external environment changes to any extent, the monitor slide is quickly adjusted to make an intermediate correction to the profile. The monitor reproduces the figures found in climb and descent graphs and presents them in a format more appropriate to the flight deck.

It is very commonplace in our present air traffic environment to be required to reach a specific altitude by a nominated distance on a climb or descent.

The pilot must quickly know whether he can comply with these requirements and once committed whether he is achieving the desired result. If a clearance is rejected or not complied with, the ATC options are generally less favourable and often create time and fuel penalties. The monitor gives an accurate indication of these parameters which assist the pilot in his decision making. The knowledge of his intermediate progress in achieving the profile allows a fine-tuning of height versus distance resulting in significant fuel economy.

During the period when the monitor was under test, it was interesting to note the reaction from the other members of the crew.

The first observation was that most crews commented that the approaches appeared high, particularly in the intermediate stages of the descent. It would appear that they have observed or practised so many conservative approaches that the "on profile" approach indeed, looked high.

Secondly, the visual clues of coastlines, runway lights, etc. are not a reliable guide to distance, especially when there is partial cloud cover which further adds to the optical illusion of being too close

The pilot needs the assurance that his airplane is where it should be at that point in time and the knowledge that a comfortable approach will follow.

The term "conservative" has no safety connotations when applied to the descent phase of flight. If the airplane is on its correct profile, it is the safest place to be, when all operational aspects are considered.

Naturally, we would not expect a glide approach under bad weather conditions. It would be considered prudent to stabilise the aircraft in the steady-thrust configuration earlier in the approach phase.

Once the monitor produces the low-fuel burn descent, it highlights the conservative approach as an expensive manoeuvre. The sensitivity of professional pilots to any form of criticism, implied or otherwise, is the catalyst required to produce low-fuel burn descents.

I will not go into the technical aspects of the monitor except to say that for each combination of airplane weight and flight altitude, there is a corresponding still air distance. This distance can then be adjusted for the prevailing head or tail wind. This final distance may be further refined according to a range of speed schedules. It is most frustrating to have worked out a profile only to find it invalid due to an ATC speed requirement. It may sound complex, however, it is very simple to use. As a result, the time required for profile calculations and cross checks are significantly reduced which, in turn, reduces pilot workload and contributes to the safety of the operation.

When ATC restrictions require a descent to a point lower than the normal profile, it will cost fuel. We must accept this fact but by using the monitor to cross the fix precisely at the altitude requested, we do not compound the fuel loss.

We have achieved the following results by use of the monitor over an extended period of assessment:

1. A zero thrust approach from cruise altitude to approximately 1500' on final approach can be achieved with positive assurance. The guess-work and rules of thumb have been eliminated.
2. Compliance with altitude restrictions and requirements can be made with precision.
3. A reduction of 50% of fuel burn compared to the fleet average for the four month survey. In fact, the monitor produces a fuel burn less than the figures shown in our performance manuals.
4. The minimum concentration from pilots to achieve their profiles, therefore reducing the flight deck workload which must enhance safety.

In achieving the minimum fuel burn with late application of thrust, two other worthwhile side benefits are obtained:

1. The minimum noise pollution in the environment.
2. The minimum burnt-fuel pollution in the lower levels of the atmosphere.

Finally in the education program to break down the conservatism of the low and slow approaches, we can say to our flight crews, "You will not be caught high anymore - refer to your monitor and assure yourself of your exact profile - it works. You can contribute immensely to our economic viability with the fuel you save on descent. It has been proved you can save up to 600 kg per descent. If you save only half that amount you can collectively save over \$2,500,000 per annum fleetwide with our 21 Boeing 747's".

In arriving at these conservative figures, it must be realised that Qantas has one of the longest stage lengths per passenger in the international arena, due to our "down-under" geographical location. We average only 20,000 descents per annum, so the fuel savings can be factored-up considerably for a domestic or short/medium haul operator.

In conclusion, it is not sufficient to say, "It is very difficult to tell when to start a descent and you will require experience before you make a proper decision". A practical solution must be proffered to save as much fuel as possible.

We, in Qantas management, feel we have made a contribution to save our precious energy by providing a simple tangible solution by means of our monitor.

The descent is the last area where pilots can impose their professional knowledge into a challenging environment of changing factors. Let us do everything possible to help them achieve this objective.

A zero thrust descent from 115 miles to 1500' on the final approach is not only professionally satisfying but is also profoundly important to the economy of our industry.

THE DELAY MANAGEMENT PROCESS

Roger E. Brubaker

Chief, Air Traffic Control Command Center
Air Traffic Service
Federal Aviation Administration

Isn't it frustrating? You rush to get to Washington National Airport, exhaust yourself trying to find a parking space, grab your bags, rush to the counter to purchase your ticket--having to wait your turn, finally you obtain your tickets and seat assignment; then you walk hurriedly to the gate just in time to hear the announcement that your flight to Chicago will be departing one hour late.

You finally board the plane and it seems a very long time before you depart; and when you get to the Chicago area you have to hold in the air for another half hour. Your first reaction is that the air traffic controllers did it to you again! And the irritation builds up, disturbing all your senses and you begin hating the system that put you in this position--you'll certainly be late for your appointment; that business deal may fall through; your mother, wife, friend or relative may be waiting to pick you up; you can't reach anyone; the phones are tied up and those "stinkers" you think, "What more do they want?"

We, in the Air Traffic Service, are equally frustrated. Not because we are flying on the same plane, not because your flight is delayed, and especially not because the controllers are "doing their thing," for it is highly unlikely that they are slowing traffic. As a matter of fact, would you believe that over 98% of system delays are not ATC induced, but caused by such uncontrollable factors as weather and equipment failure? But, someone trying to simplify the real explanation of delays, coined the phrase, "ATC delay." Moreover, since the traffic controllers, on a few well published occasions, did institute their "by the book" arrogance, the ATC delay myth was expanded to include "controller slowdown." And, that, my friends frustrates us.

We are here today to vent our frustrations and ask you to look at the causes that generate delays and to look at the delay management process. From there, we believe we can prove that "ATC delay" is a myth and what appeared as an unreasonable delay on that Washington to Chicago journey was actually a managed delay, administered expertly, and by design.

To understand the delay problem, requires an explanation as to why they occur. Delays occur usually when there are more aircraft that wish to be serviced (the demand) than can be accommodated (the capacity). This demand/capacity problem usually exists when a problem manifests itself somewhere in and around the airport. For example, Chicago's O'Hare International Airport, when using four sets of runways, two for departures and two for arrivals, is able to accommodate approximately 135 aircraft per hour. That 135 hourly figure relates to the standard distances between aircraft departing and arriving. It also relates to the number of aircraft that wish to be handled. If an additional non-conflicting runway was available to be used, the capacity could be substantially higher. An assessment of capacity takes into account runways, taxiways, high speed exits, airspace, operating procedures, and even types of aircraft that use the airport.

As I said earlier, weather plays a major role in decreasing capacity. Fog could actually stop traffic completely, icy runways would require an increase in the minimum spacing intervals between arrivals; a planned or

sudden runway closure, because of repairs, construction, debris removal, or an unforeseen constraint, all cause delays; all significantly reduce airport capacity. And, as long as the same number of aircraft insist on continuing unimpeded toward the airport, delays not only result, but accumulate quite rapidly.

The FAA cannot totally and independently eliminate delays. We do, however, attempt to manage successfully those delays during unusual circumstances so that they do not severely impact the users or the air traffic system.

The delay management process attempts to predict or respond to a capacity problem and reaches out to traffic destined for high density airports. The program assigns a significant portion of a flight's projected delay on the ground, engines off, before it departs for the delay airport. This is done very cautiously as it is a very sensitive issue with the airlines. It could be viewed that the FAA is infringing on the airlines' prerogative to dispatch aircraft.

There are several operating principles for the imposition of delay management programs:

1. The trigger for assigning ground delays is predicated on excess demand or an actual airport constraint, such as navigation equipment failure, weather phenomena, or other factors, that may significantly reduce the airport's capacity to cause delays to exceed 30 minutes and remain in excess of 30 minutes for two hours or more.
2. Delay management conserves aviation fuel by detaining aircraft on the ground, to the extent practical, until the destination airport can accommodate the flight with no more than a 30 minute arrival delay. The 30 minute arrival delay is designed to establish a holding reservoir of available aircraft to be allowed access to the airport in the event the cause for the capacity reduction is suddenly resolved.

You see, we are not sufficiently secure with our ability to forecast how long a particular airport capacity problem will remain.

3. Due to the various user or operator limitations, and subject to the availability of holding space, ground and air, the following options are available:
 - A. Ground delay.
 - B. Airborne delay.

C. Intermediate landing.

D. Split delay.

E. Substitution.

I think each of these should be explained in more detail.

A ground delay is the amount of time imposed by the air traffic control system and credited to a flight at the departure or intermediate terminal, based upon the estimated time of arrival at the delay airport. A ground delay should be absorbed at the departure gate or any other holding area on the airport surface, if gate space is critical and not available, and very importantly--with engines off! You, as a passenger, may be taking the delay at a waiting room in the terminal or aboard the aircraft depending upon how your particular carrier wishes to absorb his delay. For most flights, the ground delay option is assumed unless the operator makes a specific request to exercise another option.

A second option is the airborne delay. This option allows the operator to take the appropriate amount of delay in a holding pattern prior to reaching the arrival Center area. There are times, for many and varied reasons, that an operator must leave the departure gate or airport. He would then climb to his cruise altitude and hold in the general area of the departure center for the amount of time equal to the ground delay taken by others. This is the least desirable option because it gives no consideration to fuel burn.

Another option that might be exercised is an intermediate landing. This allows an operator to land short of the intended destination and absorb all or part of the designated delay on the ground. The operator may choose this option to combine flights destined for the same airport. There are many reasons to exercise this option.

Then, we have the option to substitute departure release times. A very intricate option, but of great value to a dispatcher with several flights to the impacted airport. He can interchange release times between aircraft, thereby placing some trips closer to schedule and others later, or, to cancel a flight entirely. A knowledgeable dispatcher with several flights has a great advantage in managing his dispatch system under this option.

These five options may be used, as air traffic conditions permit. Four of which provide a significant fuel savings potential. These options allow the users of the system as much flexibility as possible while the Air Traffic Service provides a program to manage delays and control fuel consumption.

Delay management programs began at the world's busiest airport, Chicago O'Hare. After many months of simulations; the procedures were tested in a live environment on January 7, 1976. The test results indicated a significant fuel savings could be realized when the proper options are exercised. Since January 1976, the program was soon expanded to include Stapleton Airport, at Denver, Colorado; and today may be used at any airport in the country. Fuel savings over the past several years have run into the millions of gallons and even more savings are forecasted. The key is predicting demand.

Through its use, we have learned a great deal about adjusting an airport's demand to be more in line with its capacity and we look forward to airborne holding as a thing of the past.

PART IV

ENGINEERING AND MAINTENANCE CONSERVATION STRATEGIES

PRECEDING PAGE BLANK-NOT FILMED

COMPUTERIZED ENGINE AND AIRPLANE PERFORMANCE
MONITORING PROGRAMS

M. B. Schwartz and A. E. Domke
Maintenance Operations Division
United Airlines

COMPUTERIZED ENGINE AND AIRPLANE
PERFORMANCE MONITORING PROGRAMS

ABSTRACT

An important element among the many fuel conservation activities underway within United Airlines are the computerized engine and airplane monitoring programs. These systems provide on-going information on the condition of each individual airplane and the "health" of the installed engines. Any airplane or engine performance deterioration is readily apparent and further investigation can be implemented and the necessary action taken. These programs are presented in appropriate detail. Also included in the paper is a discussion of some efforts to audit the effects of performance altering factors. For example, the Cruise Data Survey System used to measure drag differences between reverser configurations on the 727 airplanes is presented. Long term performance deterioration is discussed and the economic unfeasibility of restoring engines and airplanes to new condition. Recognizing the potential for fuel savings through better controlled ground usage of the APU, steps were taken to monitor its operation. Since this monitoring program has been in effect, over \$.5 million in fuel savings monthly have been realized.

GLOSSARY OF TERMS

ALT	PRESSURE ALTITUDE
APU	AUXILIARY POWER UNIT
CDS	CRUISE DATA SURVEY
EGT	EXHAUST GAS TEMPERATURES
EPR	ENGINE PRESSURE RATIO
ETD	ENGINE TREND MONITORING
FF	FUEL FLOW
FLM	FLIGHT LOG MONITORING
IAS	INDICATED AIRSPEED
M	MACH NUMBER
N_1	NO. 1 ROTOR SPEED
N_2	NO. 2 ROTOR SPEED
RAT	RAM AIR TEMPERATURE
SR	SPECIFIC RANGE
TAT	TOTAL AIR TEMPERATURE
TSFC	THRUST SPECIFIC FUEL CONSUMPTION
TSO	TIME SINCE OVERHAUL

COMPUTERIZED ENGINE AND AIRPLANE PERFORMANCE MONITORING PROGRAMS

About 1972, motivated to a great degree by an externally generated fuel supply problem, the U. S. airlines began to give increased attention to what might be done in the operation of air-transport to conserve fuel with minimal disruption of flight schedules, maintenance schedules, diminishing of hardware life, etc. Although United Airlines and other airlines have always had a great concern for fuel conservation because of the fuel costs in the economic equation, the nearly exponential increase in fuel costs during the early 70's was an unmistakable motivating signal that more fuel accountability was required and improved means of finding operational "fuel leaks" was needed. In 1973, the cost of a gallon of turbine fuel was \$.13, while at this time the cost of a gallon of fuel is about \$1.10, or an 840% increase over 8 years! It is within this all too familiar context that I would like to discuss the tools used by United Airlines to achieve a high degree of fuel consumption accountability, and our efforts to find the "fuel leaks" and fix them.

My discussion today will cover techniques/methods which are used in monitoring fuel consumption at the United Airlines Maintenance Operations Division. There are other fuel conservation activities underway within other United departments as you have heard and will hear about later at this session. Here are the main topic headings I will discuss:

- Flight Log Monitoring of Turbine Engines
- Cruise Data Survey System
- Cruise Data Survey System - "Junior"
- Use of Monitoring Tools - Case Histories
- APU Usage Monitoring Program

Having embellished upon these monitoring devices, I will present some case histories where our techniques provided the information necessary to enable us to take certain engine or airplane maintenance action relating ultimately to fuel conservation.

FLIGHT LOG MONITORING OF TURBINE ENGINES

First, let's look at the flight log monitoring of turbine engines. The basic engine and airplane operating data for the FLM (Flight Log Monitoring) program is recorded by the Second Officer (Flight Engineer) on a special flight log book coupon during stabilized cruise. This data coupon, known as the Performance Monitoring Record, is located on the top of the regular aircraft log sheet (Figure 1). The flight crew turns in a carbon copy of the log sheet to the local station dispatch with their other flight papers. This routine determines the frequency that performance monitoring data is recorded since the airline procedures require a new aircraft log sheet after a flight crew change or a flight number change. Normally, at least two data samples per day are taken.

The communications people at designated United stations transmit the data coupon information to the San Francisco Maintenance Base Computer Center to be stored on tape until 2400 hours Pacific time, which is the cutoff time for each day's data. While this may seem to be too early to cut off input, over 99% of United's flights for that day have completed their trips before 2400 hours, Pacific time. The input is processed during the night so that the engine performance analysis will be available by 0800 hours the next day. Information recorded by the flight crew on the engine data coupon is as follows:

- 1) Four air data parameters (RAT/TAT, IAS, ALT, M)
- 2) Five engine gas generator parameters (N_1 and N_2 , EPR, EGT and FF)
- 3) Oil pressure
- 4) Identification data (airplane number, TSO, date, log number, etc.)

The daily printout of engine performance monitoring trend data would be over 2,200 pages of printed hard copy. However, microfiche output is used to reduce the volume of the data to manageable proportions. The daily routine output consists of

- 1) Audit listing of the daily input listing
- 2) Index of all engines that exceed the individual entry and/or trend limits
- 3) Output sheet for each engine with additional page of historical data on those which exceeded limits (Figure 2)

The computer program accepts the input data in any sequence with a maximum data age of 15 days. The airplane TSO, date, and log sheet number are tested to verify proper sequence. The input gas generator data are corrected for the environmental conditions (ALT, MACH, RAT/TAT) and the difference between the observed data and the engine manufacturer's idealized performance data is calculated. This difference between the engine's actual operation and the idealized performance is trended after several data screens and statistical manipulations.

The program has various screens and tests to categorize the trend data input. The data are statistically divided into unbelievable, abnormal, and normal categories. Unbelievable data (for example, duplicate logs) are immediately rejected and forgotten. The abnormal data will be rejected for two log inputs. When the computer recognizes the third abnormal data log in a row, it will accept this log. However, it does not retrieve the two previously rejected logs.

For each engine parameter, the trend is calculated by an exponential smoothing method. The method adds a fraction of the difference between the previous smoothed (trend) value and the latest observed value. In the program, the trend is smoothed twice by two successive smoothing factors to reduce data scatter. By this means, the moving trend value is damped out to show the real deviations from baseline.

The FLM program is used to monitor approximately 2,500 engines. Obviously, this is far too much data to be reviewed by two analysts every day. The computer program has trend rate of change limits on each parameter that provides automatic warnings on the data printout and list the deviating engine on the daily exception printout.

The amount of log-to-log parameter change and/or trend required to "flag" an engine and produce a printout has been determined by Engineering and is based on the accuracy of the measuring equipment and the natural scatter of the gas generator parameters in an engine fleet. The limits chosen are very important, for if they are too loose, the system may miss important clues to engine problems. The daily "exception" printout usually lists 40-50 engines requiring further review by the analysts. So, essentially, the computer does about 95% of our monitoring.

The FLM System is basically the "umbrella" system for collecting all the engine and flight data for the EMP (Engine Monitoring Program) and the CDS (Cruise Data Survey). The EMP is fairly narrow in scope and monitors only engine parameters on a day-to-day basis. Based on the observed data, engines are removed when data trends indicate an incipient hardware failure or when a parameter such as EGT exceeds legal limits. Engines are rarely removed because of high fuel consumption alone. However, when engines are removed for mechanical problems it is not uncommon for the repair to improve the fuel consumption.

CRUISE DATA SURVEY SYSTEM

Maintaining a current and accurate data base for flight planning has always been an important and time consuming function of any airline operational engineering group. This statement is certainly as valid today as it has been in the past. However, it has now taken on new meaning and importance in the context of the airline operators' fuel conservation efforts. As the number of models and size of fleets have increased, so have the importance of this function and the time involved.

The need to provide flight crews with accurate flight plans on a consistent and accurate basis and the equally important knowledge of the airplane's drag levels/fuel burnout characteristics from a conservation standpoint, provided the primary impetus for the evolution of the CDS System. As many of you are aware, the airlines generally accept and use the initial performance information supplied by the manufacturer. However, many airlines, in conjunction with the airplane manufacturer, conduct 8 to 10 hours of controlled flight tests to validate the manufacturers' performance data. For United, this is usually conducted with one of the fully instrumented airplanes in the manufacturer's flight test program. Any significant differences between the manufacturer's original performance data (drag levels) and that measured during the joint flight test program, may be used to adjust the original basic drag levels if appropriate. Having established the initial drag baseline for a new airplane, the continuing exercise of monitoring and maintaining that baseline comes into play immediately.

Early in the operation of a new airplane, it is usually apparent that there are differences between the manufacturer's performance baseline and what is observed in the airline's actual day-to-day operation. The primary causes for this are the conditions under which the data measurements were made. The manufacturer uses ideal flying conditions and flying techniques, and the airline operator uses day in and day out line conditions relying upon the large volumes of observed data to provide a statistically reliable assessment of performance. All pertinent airplane and engine performance parameters are compared against the data base delivered with a new airplane fleet. In a very short time, perhaps a few months, sufficient actual flight observed data has been accumulated to make appropriate adjustments to the performance data used for flight planning and related functions. The CDS System is the essential component in this process.

Again, in the context of conservation, it is necessary to have a tool for not only measuring the "fuel leaks", but a tool for sorting them out where they exist. Our experience with monitoring airplane drag of more than twenty years ago or so, brought us to the conclusion that computerization was the only way to manage the large volumes of data and process it in a timely manner. Formerly, after an aircraft had been in service for some time, flight crews would typically finish a trip with less fuel remaining than the flight plan called for. This crew would write a note in the log book stating that the airplane was a "high fuel burner". The next crew taking the airplane saw the note and loaded an additional 5,000 pounds of fuel; certainly not an unreasonable thing to do. In a relatively short time, all airplanes in a particular fleet had the reputation of having "high drag" so extra fuel was boarded above that specified by the flight plan by all flight crews.

As the "squawks" from the flight crews became loud and clear, a performance survey was conducted in which special forms were distributed to the line crews, the pertinent performance data entered by the crew, and returned to the Operational Engineering Section for analysis. The results of such a survey were processed by hand and eventually a correction, if felt necessary, would be made to the airplane's performance data used in the flight planning process. It is obvious that this process was time consuming and not very efficient.

The Operational Engineering function of any airline has the responsibility to maintain the accuracy and currency of the performance data used in flight planning. If the performance data is optimistic and flight crews lose confidence in the flight plans, the service function of the engineering organization is undermined and is difficult to re-establish. Due to this lack of confidence, flight crews require that extra fuel be loaded to cover both the real and imagined deficiencies. If the performance data, on the other hand, is very conservative, unnecessary or excess fuel is loaded that will not be burned and is not needed to satisfy reserve fuel requirements. This fuel is only along for the ride. In either of these cases, some extra fuel is burned to carry along the extra "uncertainty" fuel which results from poor performance data. While it may be small on a trip-by-trip basis, it becomes significant for large fleets of airplanes. For example, if each of United's 300 (+ a few) airplanes carry 100 pounds (15 gallons) of extra fuel on every trip, the additional fuel required just to carry the extra weight would increase the annual fuel bill by \$632,000. Again, the CDS System is the cornerstone for the work we do in this area.

The CDS System makes use of the data collected from the same log book coupon as used for turbine engine monitoring. This system has become the primary element in the process of identifying and repairing airplanes which display abnormally high fuel consumption characteristics. The increased attention to fuel conservation and the relationship to airframe maintenance and aerodynamic cleanliness has resulted in this fairly sophisticated monitoring tool. The present system monitors fleet cruise Mach numbers and airplane performance, drag and fuel mileage characteristics. Figure 3 shows the flow of the observed input data to obtain a specific range comparison, or a measure of the fuel flow. Figure 4 shows the flow of the observed data to obtain a measure of relative drag in terms of EPR (engine pressure ratio). The basic equations which make up the heart of the program are shown in Figures 5 and 6. These are basic aerodynamic, thermodynamic, and statistical relationships, of course. As indicated, the program uses observed airplane data to compute values of power setting parameter, EPR (or N_1), and fuel mileage parameter, SR (specific range). These values are compared with reference baseline data and the percentage difference and standard deviation is computed for each parameter. Figures 7, 8, 9, 10 and 11, illustrate the computer output for individual airplanes and the fleet as a whole. These typical outputs are generated and analyzed on a monthly basis.

This information is used to provide early recognition of airframe deterioration and condition as previously discussed, increased drag, and malfunctioning airplane systems which may result in increased fuel consumption. Early recognition, of course, will result in expeditious corrective action to recover as much of the original airplane performance as feasible. In addition, this information assists in assessing airplane performance levels used as inputs to long range fleet planning. Long range plans and forecasts related to airplane fuel consumption and route utilization obviously will not be valid if airplane performance is not known or is allowed to deteriorate. Figure 12 is an overview of the CDS System showing the major steps to updating the basic performance data or taking appropriate maintenance action.

Because the airplane performance monitored by the CDS System is a function of many conditions and parameters and because it is measured in day-to-day line operation rather than a "laboratory" setting, there is some data scatter or uncertainty. Therefore, to allow the accumulation of enough data to provide statistically significant results, the CDS computer program is run monthly rather than daily. When "high burner" airplanes are observed, the information is passed along to the System Engineer for analysis. Typical fixes that result from "flagging" by the CDS System are control surface rigging, control surface seal leakage, and airspeed discrepancies. These problems are relatively easy to find and fix. When the problem is easy to fix, it most likely has economic payback in terms of fuel savings. The drag and fuel consumption trend analysis from the CDS System is performed manually at this time, although future plans call for this function to be accomplished by computer.

A companion program to the CDS System as discussed here is the Mach Survey. This program uses the same data base to provide an analysis of cruise speeds and a check on the pitot-static (airspeed and altitude) systems on the airplanes. Although this program is not directly related to fuel conservation, on occasion, it can provide supporting evidence that maintenance action should be taken on a particular airplane to reduce its fuel consumption.

CRUISE DATA SURVEY SYSTEM - "JUNIOR"

This program uses observed airplane data to compute values of the power setting parameter, EPR or N_1 , and fuel mileage parameters, specific range. These values are compared with reference baseline data and the percentage difference is calculated. The mean percentage difference and standard deviation is computed for each parameter. The calculation logic and reference data for this program are exact duplicates of that used in the "parent" CDS computer program discussed previously. The "junior" program is used to process small amounts of data on the IBM 1130 computer installation available in the United Operational Engineering section. This provides convenient and rapid turnaround of flight data generated by special flight tests conducted within the Engineering Department. Figure 13 is an example of the output generated by this program.

USE OF MONITORING TOOLS - CASE HISTORIES

Having discussed the available monitoring tools that have been developed over the last 20 years, we will take a look at some typical applications that have produced excellent information on airplane fuel consumption performance and performance shifts.

CASCADE REVERSER DRAG ANALYSIS

Reports from the manufacturer and several airline operators concerning additional drag due to fixed cascade reverser installations on 727 Advanced aircraft, prompted a review of cruise data on United aircraft to determine if retrofit to this type of reverser for the older 727's would be an appropriate option (Figure 14). With the high utilization of airplanes on the San Francisco-Reno "commuter" operation, the four 727-100 airplanes selected for this operation were retrofitted with the cascade reverser system because of the reverser's established reliability (and low maintenance) under high cycle usage. Making use of the line observed data and the CDS System, the 727-100 cruise specific range deviation from the flight manual baseline was analyzed for these four aircraft designated as Reno Commuters (72XX nose numbers) and compared before and after, and with the 727-100 fleet as a whole.

Three time periods were analyzed, one with 100 percent deflector door reversers, one with a mixed configuration, and one with 100 percent cascades. The cruise performance of the four 72XX aircraft and that of the short-body fleet as a whole, was compared between the first and last time period. The average cruise performance of the 72XX aircraft was also compared to the fleet average. The performance deviations were assumed to be independent of time during each analysis period. That is, the slight decrease in overall fleet cruise performance over time was approximated by three steps, one for each time period. Figure 15 illustrates the percent deviation from the flight manual baseline for each 72XX aircraft, the average over the four aircraft, and the fleet average. The fleet data includes the four 72XX aircraft as it was impractical to recompute the fleet statistics without them.

Comparing the deviation from flight manual standard between the period when the 72XX aircraft were entirely deflector door equipped and the period that they were entirely cascade equipped results in a mean decrease of 0.76 percent as shown in Figure 16. Comparison of the short-body fleet statistics over the same time periods indicates a mean decrease of 0.15 percent. The latter decrease is ostensibly the deterioration that would be normally expected in an average unmodified aircraft.

The large number of data points available (about 3,000 for 72XX aircraft and about 75,000 for the entire fleet) makes the assumption of a normal distribution appropriate and the difference between the mean deterioration of the 72XX aircraft and the fleet as a whole is significant to well above the 99 percent level. Thus, the apparent decrease in performance due to the difference in reverser installation is the difference of the averages or 0.61 percent. Although the average

performance of the 72XX aircraft at any given time was worse than the fleet average, there was no evidence that performance deterioration was occurring at a faster rate in these aircraft.

DC-10 AIRSPEED POSITION ERROR

As a result of routine performance monitoring of the DC-10 fleet, an airspeed position error for the airplanes with a revised forward wing/fuselage fillet was detected. When flying at the cruise Mach number (.83), the unanticipated change in position error attributed to this fillet was such that the indicated airspeed was about 2 KTS low. The indicated altitude was about 115 feet low, and the indicated Mach number was .005 lower than true Mach number. The manufacturer corrected this problem by issuing instructions for appropriate wiring modifications to the air data computer. This provided the necessary accuracy of the airspeed and altitude display to bring the airplanes affected to acceptable agreement with the aircraft performance. This unnoticed error had the potential of costing \$90,000 per year in fuel for those five airplanes.

RESTORING AND MAINTAINING PERFORMANCE LEVELS

Jet airplanes are designed with very high cruise efficiency in terms of both speed and fuel consumption. Once a new airplane is subjected to the rigors of line operation, its overall performance generally begins to deteriorate due to both a loss of aerodynamic cleanliness and engine deterioration. The rate of this deterioration is a function of airplane utilization, the operating environment, and the particular airline maintenance procedures. In general, a typical deterioration over a three year period could be in the order of 3 to 4 percent. The routine airplane performance monitoring done by Operational Engineering indicated a general deterioration of the DC-10 cruise fuel consumption performance as early as 1973-74. The reduced performance became noticeable to flight crews during 1974 in the form of higher than planned enroute fuel burnout.

Several factors tended to influence the response to this particular problem; the Arab oil embargo fuel crisis was at its peak, we had no long term experience with large, high-bypass ratio turbofan engine deterioration, and new airplanes were constantly being added to the fleet which, on a fleet-wide basis, moderated the effect of deterioration in the older airplanes.

In the spring of 1975, the subject of DC-10 high fuel consumption became a work item involving several groups within Engineering. By late summer, Douglas and General Electric were brought into the discussions. Several months were spent exploring the problem, including an Airplane Performance Audit by Douglas personnel during November, 1975, to verify the UAL reported performance levels.

The plan of action which developed involved a DC-10 airplane. This airplane was among the very worst in the fleet and had a long history of high fuel consumption. The plan was simply to change all of the engines and rerig all of the flight controls in an attempt to improve the performance. Some time earlier, United had committed to accomplish a General Electric developed CF6 refurbishment program. The primary benefits of this program were to be improved life and reliability. However, several of the projects also would have a favorable effect on fuel consumption. Therefore, three of the refurbished engines were installed on the airplane. A time period of two months prior to this date was established as a baseline period. Cruise data was obtained from the normal FLM System.

The analysis of this airplane provided several important conclusions pertaining to airplane and engine performance. Most significantly, it demonstrated our ability using the CDS System with large volumes of observed flight data to measure fuel (drag) consumption differences for whatever causes to within .5 percent. The analysis also showed that turbine engines could be restored to nearly original performance levels with an intensive "tune-up". In addition to the engine tune-up, the flight control systems were carefully rerigged and reduced the fuel consumption by about .7 percent. Although this flight test indicated that airplanes and engines can be restored to nearly original condition, the initial level of performance is difficult, if not impossible, to maintain. (Figure 17)

DC-10 FIXED NOZZLE FLIGHT TESTS

As a part of the continuing drag cleanup program at United in late 1978, the DC-10 turbine reverser was considered to be a potential source of parasite drag. Any hardware cleanup in this area had the possibility of improving the maintenance and reliability of the system with little impact on landing stopping performance. Fixed nozzle flight tests were conducted to determine the effect on airplane drag and fuel consumption of replacing the existing deactivated turbine reverser installation with fixed cone exhaust nozzles (Figure 18). This was accomplished by flying the same airplane with both configurations back to back on two consecutive days. Airplane performance was measured in both cases and the results compared. The difference in performance, all other things being kept equal, was found to be due to installation of the fixed nozzles.

The performance measurements were the classic "speed-power" points at typical cruise conditions, i.e., constant altitude, constant Mach number and very stable flight conditions. Numerous data points were taken. In each case, the following information was recorded: airplane weight and related data, flight conditions (speed, altitude, etc.) and engine parameters (most importantly, fuel flow). Since the differences in airplane performance due to the change in configuration were anticipated to be relatively small, every effort was made to reduce the number of unknowns and minimize the errors that are inherent in precise measurement of complicated systems.

The necessity of obtaining accurate data from these flight tests was underscored by the magnitude of both the potential costs and savings. The decision to retrofit fixed nozzles on the DC-10 fleet essentially rested on the results of these tests. Such a retrofit would represent a cost of roughly \$3½ million. On the other hand, preliminary estimates indicated the fuel savings resulting from the retrofit could be on the order of \$1 million per year at that time. As you can see, it was necessary to get the right answer.

The advertised fuel savings for this project was supposed to be somewhat less than 1 percent. Based on our previous experience and the size of the "stakes", we chose not to use our routine monitoring programs in this case. Instead, we elected to use a comprehensive test flight data analysis process. This analysis was conducted by both our Engineering Department and independently, by the airplane manufacturer with good agreement. The final results indicated the fuel mileage was improved by .57 percent. This fuel savings, along with the maintenance savings, led to the decision to retrofit the DC-10 with the fixed nozzle exhaust. The raw performance data was also reduced using the CDS "junior" program, but with inconclusive results. This case demonstrates the necessity of recognizing the limitations of the routine monitoring system and using it accordingly.

MONITORING LONG TERM PERFORMANCE DETERIORATION

Since commencing jet service, United's Engineering Department has periodically examined the specific fuel consumption of the United turbine engine fleet. As stated previously, there is a relatively rapid decrease in specific range (fuel mileage) during the first two to three years of operation. Figure 19 shows this deterioration with age for United's DC-10 airplanes, but is typical for all turbine power airplanes. Of over 1,600 flights representing the regression line shown, less than 50 flight points fell outside 2 sigma. It can be noted from the plot, that nearly 2 percent of the deterioration occurred in about the first 4,000 hours, or the first 18 months, and stabilized at about 3 percent at the end of 16,000 hours or about 60 months. This total long term deterioration of 3 percent we feel is shared by both airframe and engine. Aerodynamic cleanliness probably accounts for about .5 percent of the total 3 percent.

Increased aerodynamic drag can be caused by dents, aerodynamic seal leakage and pressurization leakage. Engine cowling is highly susceptible to damage and often results in repairs of dents and holes that are less than ideal. Aerodynamic seals prevent air in a high pressure region on or within an aerodynamic surface from leaking or "pumping" to areas of lower pressure. Normal deterioration of seals can result in this kind of pumping at the wing to body intersection, through leading or trailing edge cavities or through landing gear cavities. This kind of "aging" of the airframe is difficult, if not impossible, to repair. The total deficit, which is only .5 percent, is made up of an accumulation of many small drag items, each one of which would be hard, if not impossible, to restore to new condition.

The engine deterioration is believed to be due primarily to initial compressor and hot section deterioration such as opening up of seal clearances, blade tip clearances, dirt contamination of the compressors, and nozzle guide vane bowing. The engine quickly loses 1-2 percent efficiency. This can be attributed to rapid loss of the fine tuning done by the manufacturer in the final stages of his TSFC development.

Several engine-related systems can also contribute to increased fuel consumption. Pneumatic duct leakage and anti-ice valve leakage are known contributors. Reverser seal leakage can also contribute to losses on certain reverser designs. The estimated effect of component deterioration on TSFC is shown in Figure 20.

How can we recover the lost engine efficiency? We do not have facilities to evaluate the effect of engine component deterioration and seal clearance on the efficiency of each engine model. In general, we rely on the manufacturers' calculations and test results of these effects. Extensive studies and testing by the engine manufacturers and the NASA Lewis Research Center are providing the answers to exactly what must be done to restore lost engine efficiency. It must be kept in mind, however, that while fuel conservation is of high importance, it necessarily must be considered as just one more economic factor in commercial aviation. If the cost of restoration outweighs the fuel savings, then the effort is not justified. This again underscores the importance of good monitoring to arrive at the proper business decisions.

APU USAGE MONITORING PROGRAM

Having recognized the potential for fuel savings through better controlled ground usage of the APU, initial steps were taken to monitor its operation. The primary criteria for such a monitoring procedure of course, required the usual, the instrumentation must be simple and reliable and crew workload increase must not be significant. An appropriate totalizing hourmeter of proven reliability used on various United ground equipment was selected to do the job. The hourmeter was installed in an accessible location at the Second Officer's station. It was connected directly to the APU master switch, thus, any time the APU master switch would be "ON", the hourmeter would be energized. This method eliminated the complexity associated with typical hourmeter installations that only monitor APU operating time above a certain operating speed.

The cost of operating an APU compared with a ground power unit is about 10 to 1. Installation of an APU hourmeter of itself, will not result in fuel savings. It was anticipated that with the high visibility of APU usage afforded by monitoring its usage, a new level of conservation awareness would be instilled among all ground APU users. The monitoring system would provide a means of accountability and given incentive to operate the APU only when absolutely required. Basically, the system works as shown in Figure 21. The hourmeter readings are recorded by the flight crew on the airplane flight log data coupon.

The flight log is turned in at the local dispatch office and input into the APU hourmeter program which is a part of the basic FLM program. The output data is printed for monthly or more frequent review and analysis. The data analysis is forwarded to Flight Operations and the Line Maintenance organizations for information and action as required. Figure 22 is a plot of APU fuel usage on the United system showing the dramatic reduction in usage after seasonal adjustments since implementing the monitoring system. Figure 22 shows an average reduction of approximately 25 percent in APU fuel consumption for all fleet types. System-wide, overall APU fuel costs have been running about \$500,000 to \$700,000 less per month since the APU management program was implemented.

In conclusion, our experience shows the use of large volumes of airplane and engine performance data is an excellent means of monitoring fleet performance at minimal cost. Our observations have shown that most initial and long term performance deterioration occurs over a three to four year period. Of that, less than .5 percent can be attributed to the airframe aerodynamic condition. Past studies have indicated there is little hope of being able to justify an attempt at reducing engine fuel consumption by replacing high-time components with new ones. Engine performance determines how far the engine can be allowed to deteriorate. Typical of those limits which must be monitored to prevent mechanical failure or reduced airplane performance are EGT, Thrust-EPR relationship change, and rotor speed limits.

Although there are the inherent limits to maintaining airplanes and engines to new condition, the primary role of the monitoring programs as they relate to fuel conservation is to spot those wide individual airplane or engine excursions from the normal performance where fixes can be made, to provide a quality performance monitoring device whenever major changes in the airframe or engine configurations are contemplated, and provide a continual track of the airplane fleet performance levels to allow appropriate adjustments to the flight planning data base.

The computerized monitoring of airplanes, engines and APU's is an important function in our efforts to save fuel. However, monitoring is only one facet of our engineering and maintenance fuel conservation effort. Many of our maintenance procedures and projects reflect a high level of fuel conservation awareness among the engineers. This is reflected, too, in the development of specifications for new equipment, whether it be for lighter weight seats, the latest application of electronics in the form of a sophisticated flight management system or the use of recent aerodynamic advances in the new airplane designs we evaluate. Operational Engineering has a complete line of airplane performance analysis programs. These are used to evaluate and optimize airplane operating procedures and to generate performance data for the flight manuals, flight planning data base, fleet and schedule planning organization, and for use in cost/benefit studies. In summary, the engineering and maintenance role provides a vital contribution to the continued operation and economic health of the airline. As we have seen, computerized monitoring of airplane, engine, and APU performance is an important function in the overall fuel conservation program.

SPECIFIC RANGE COMPARISON
CRUISE DATA SURVEY

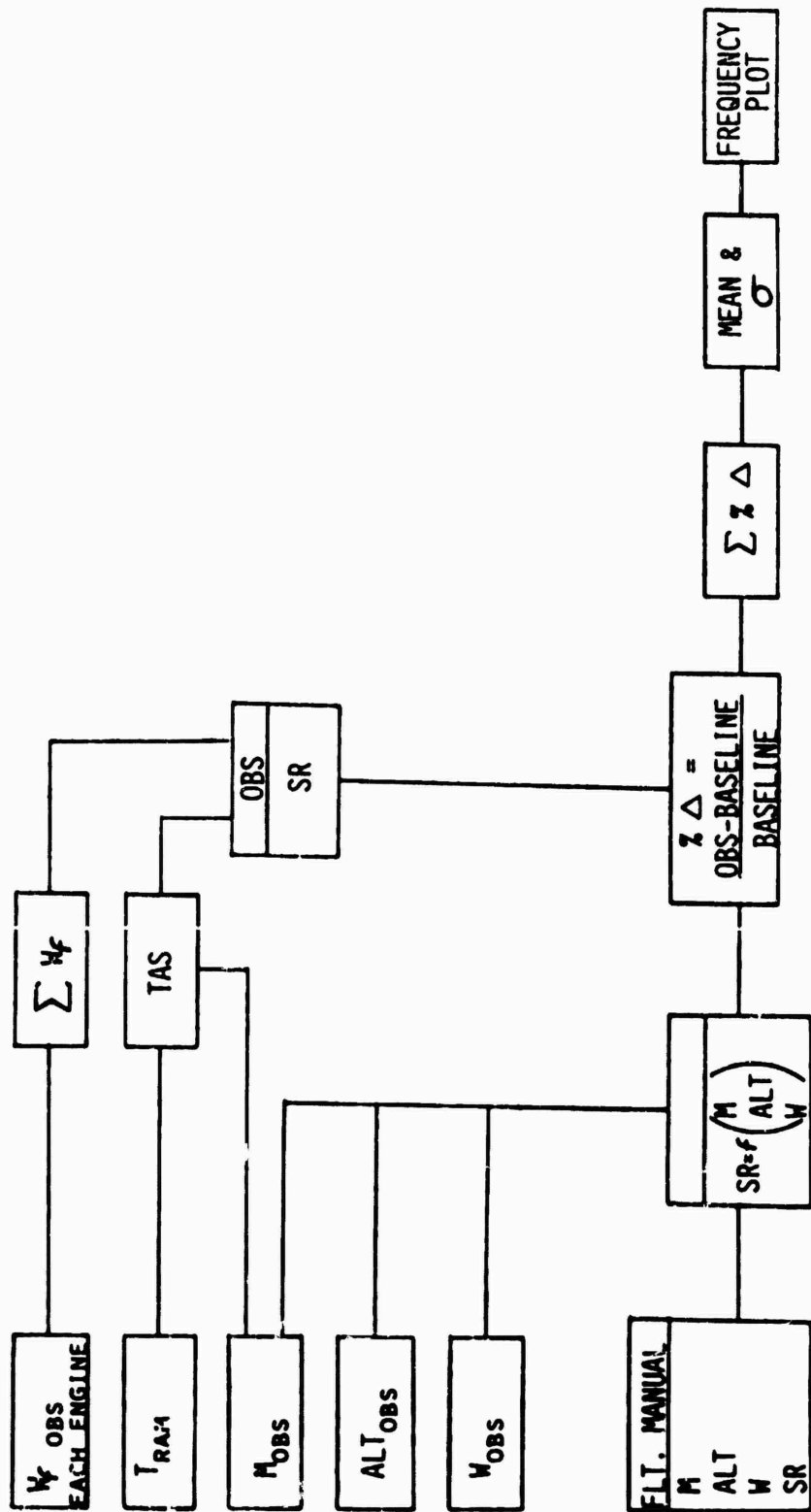

Figure 3

POWER SETTING COMPARISON

CRUISE DATA SURVEY

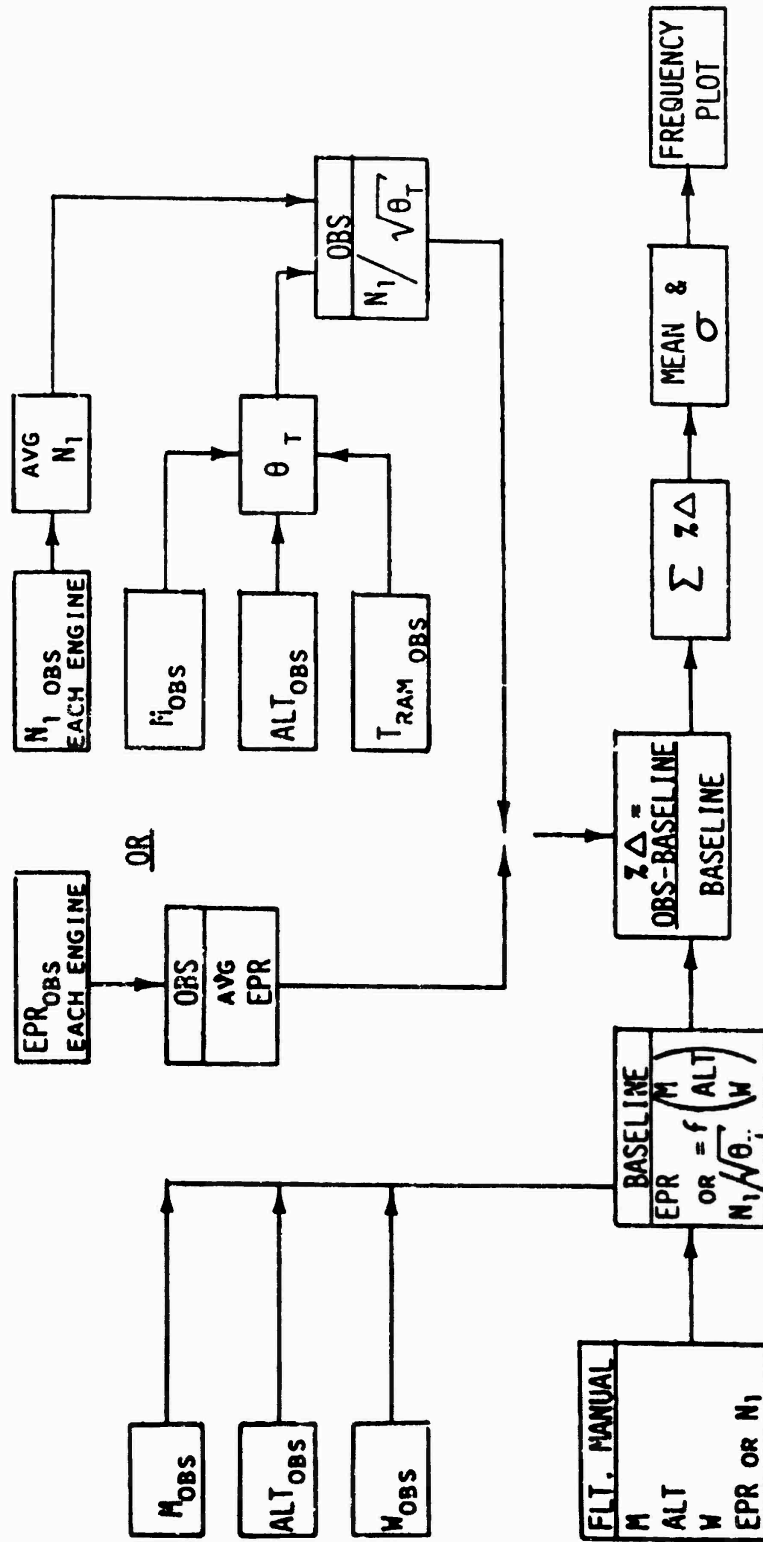

Figure 4

THEORY AND EQUATIONS

The basic function of this program is to compare observed airplane data with reference data and evaluate any difference. The parameters evaluated are thrust setting and specific range.

BASIC RELATIONSHIPS

$$\text{Average observed EPR (or } N_1) = \frac{\Sigma \text{ EPR (or } N_1) \text{ for each engine}}{\text{Number of engines}}$$

$$\text{Observed Specific Range} = \frac{\text{True airspeed}}{\Sigma \text{Fuel flow for each airplane}}$$

$$\text{True Airspeed} = Ma_0 \sqrt{\frac{T_{\text{ram}} + 273.16}{(1 + .2KM^2)T_0}}$$

t, T	Air temperature °C, °K
M	Observed Mach number
K	Ram air temperature recovery factor
a	Speed of sound

Figure 5

THEORY AND EQUATIONS

RELATIVE DEVIATION FROM REFERENCE, PERCENT

$$\Delta \% = 100 \left(\frac{\text{Observed} - \text{Reference}}{\text{Reference}} \right)$$

STATISTICAL ANALYSIS

$$\text{Average} = \frac{\sum s}{n}$$

$$\text{Standard Deviation} = \sqrt{\frac{\sum (s^2) - (\sum s)^2/n}{n - 1}}$$

s $\Delta\%$ for one airplane data record

n Number of data records analyzed

Figure 6

ALP PLANE CRUISE PERFORMANCE SURVEY

100 4372
REPORT 1
TABLE

SURVEY PERIOD 2/1/81 TO 2/28/81

ALP PLANE	PERCENT DEVIATION OF (L/D OR M) FROM REF			NO. OBS	PERCENT DEVIATION OF SPECIFIC RANGE FROM REF		
	MIN	AVG	SD		MIN	AVG	SD
4701	2.8	1.6	2.17	20	-2.04	2.25	
4702	1.7	1.40	1.75	20	-1.19	2.05	
4710	1.7	1.40	1.75	20	-2.78	2.04	
4711	1.7	1.40	1.75	20	-2.78	2.24	
4712	1.7	1.40	1.75	20	-2.78	2.24	
4713	1.7	1.40	1.75	20	-2.78	2.24	
4714	1.7	1.40	1.75	20	-2.78	2.24	
4715	1.7	1.40	1.75	20	-2.78	2.24	
4716	1.7	1.40	1.75	20	-2.78	2.24	
4717	1.7	1.40	1.75	20	-2.78	2.24	
4718	1.7	1.40	1.75	20	-2.78	2.24	
4719	1.7	1.40	1.75	20	-2.78	2.24	
4720	1.7	1.40	1.75	20	-2.78	2.24	
4721	1.7	1.40	1.75	20	-2.78	2.24	
4722	1.7	1.40	1.75	20	-2.78	2.24	
4723	1.7	1.40	1.75	20	-2.78	2.24	
4724	1.7	1.40	1.75	20	-2.78	2.24	
4725	1.7	1.40	1.75	20	-2.78	2.24	
4726	1.7	1.40	1.75	20	-2.78	2.24	
4727	1.7	1.40	1.75	20	-2.78	2.24	
4728	1.7	1.40	1.75	20	-2.78	2.24	
4729	1.7	1.40	1.75	20	-2.78	2.24	
4730	1.7	1.40	1.75	20	-2.78	2.24	
4731	1.7	1.40	1.75	20	-2.78	2.24	
4732	1.7	1.40	1.75	20	-2.78	2.24	
4733	1.7	1.40	1.75	20	-2.78	2.24	
4734	1.7	1.40	1.75	20	-2.78	2.24	
4735	1.7	1.40	1.75	20	-2.78	2.24	
4736	1.7	1.40	1.75	20	-2.78	2.24	
4737	1.7	1.40	1.75	20	-2.78	2.24	
4738	1.7	1.40	1.75	20	-2.78	2.24	
4739	1.7	1.40	1.75	20	-2.78	2.24	
4740	1.7	1.40	1.75	20	-2.78	2.24	
4741	1.7	1.40	1.75	20	-2.78	2.24	
4742	1.7	1.40	1.75	20	-2.78	2.24	
4743	1.7	1.40	1.75	20	-2.78	2.24	
4744	1.7	1.40	1.75	20	-2.78	2.24	
4745	1.7	1.40	1.75	20	-2.78	2.24	
4746	1.7	1.40	1.75	20	-2.78	2.24	
4747	1.7	1.40	1.75	20	-2.78	2.24	
4748	1.7	1.40	1.75	20	-2.78	2.24	
4749	1.7	1.40	1.75	20	-2.78	2.24	
4750	1.7	1.40	1.75	20	-2.78	2.24	
4751	1.7	1.40	1.75	20	-2.78	2.24	
4752	1.7	1.40	1.75	20	-2.78	2.24	
4753	1.7	1.40	1.75	20	-2.78	2.24	
4754	1.7	1.40	1.75	20	-2.78	2.24	
4755	1.7	1.40	1.75	20	-2.78	2.24	
4756	1.7	1.40	1.75	20	-2.78	2.24	
4757	1.7	1.40	1.75	20	-2.78	2.24	
4758	1.7	1.40	1.75	20	-2.78	2.24	
4759	1.7	1.40	1.75	20	-2.78	2.24	
4760	1.7	1.40	1.75	20	-2.78	2.24	
FLEET AGGREGATE	542	1.54	1.87	644	-1.82	2.20	

Figure 7

AIRPLANE COUSE PERFORMANCE SURVEY

000.0373
REPORT 3
0716

4715
7777777 11 0000
7 7 11 0000
7 7 11 0000
7 7 11 0000

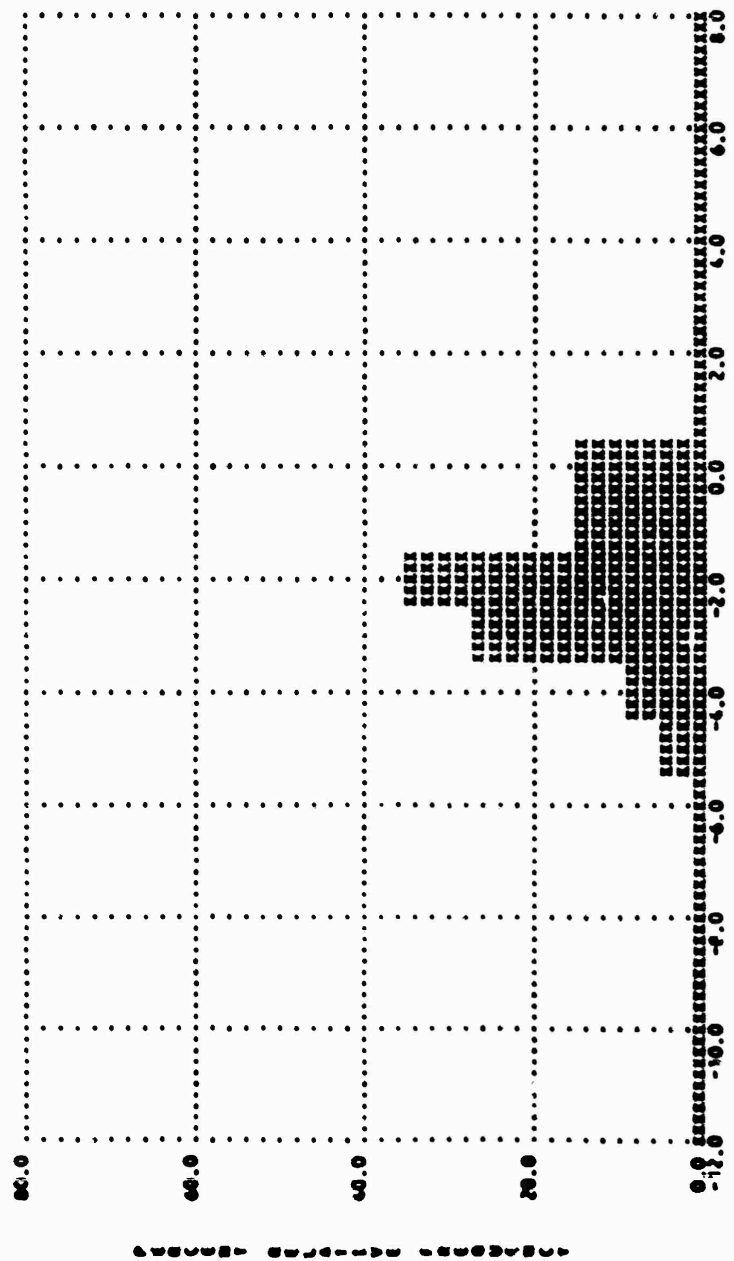

SPECIFIC RANGE PERCENT DEVIATION FROM REFERENCE

SURVEY PERIOD 2/ 1/81 TO 2/28/81
 AVERAGE OF PCT DEVIATION = -2.115
 STANDARD DEVIATION OF PCT DEVIATION = 1.343
 NUM OF OBS = 23

Figure 9

ALBANY AIRPLANE CRUISE PERFORMANCE SURVEY

200 4372
REPORT #
6716

4715
777777 11 0000
777777 11 0000
777777 11 0000
777777 11 0000
777777 11 0000

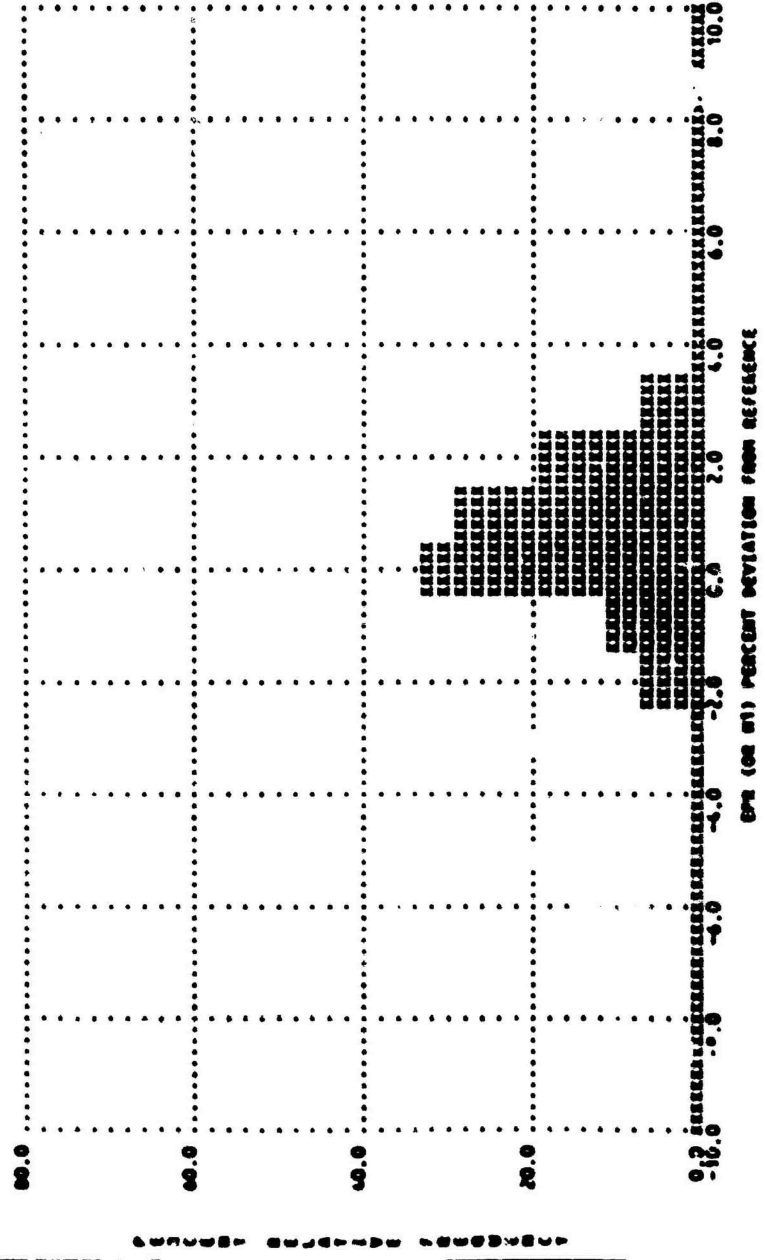

SURVEY PERIOD 2/ 1/81 TO 2/28/81
 MEAN OF OBS = 29 AVERAGE W/ PCT DEVIATION = .604 STANDARD DEVIATION OF PCT DEVIATION = 1.279
 EPM (OR MT) PERCENT DEVIATION FROM REFERENCE

Figure 11

CRUISE DATA SURVEY SYSTEM

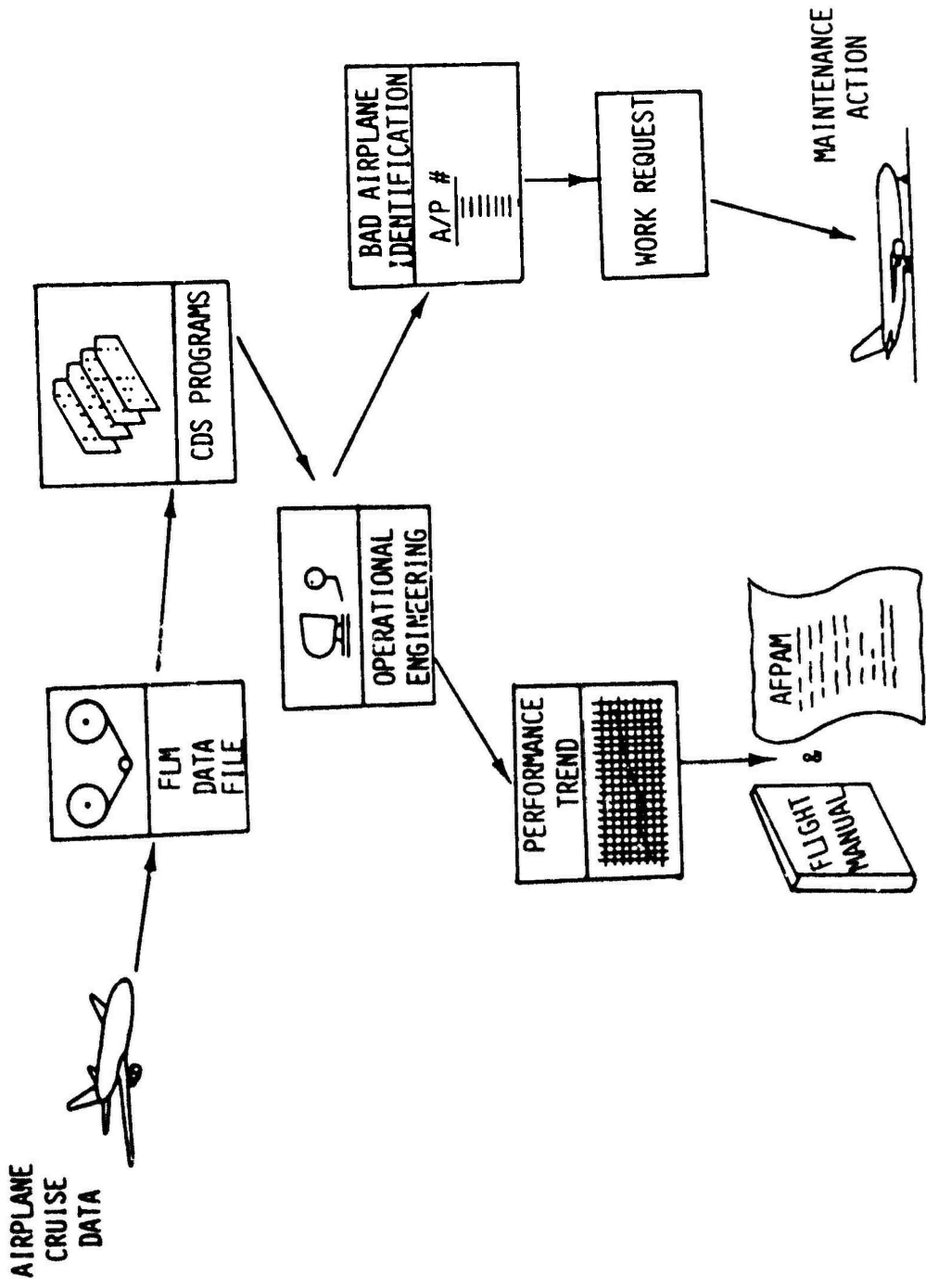

Figure 12

PROGRAM CDSJR

*
 * A/P 3538 INITIAL SERVICE EVALUATION *
 *
 * FLM DATA POINTS HAVE FOUR DIGIT DATA POINT NO. *
 * DATA FROM SPEDIAL FORMS HAVE THREE DIGIT DATA POINT NO. *
 *
 * ALL QUESTIONABLE INPUT DATA REMOVED JAN 16 *
 * ALL INPUT DATA WITH RESULTS MORE THAN ONE SIGMA FROM *
 * THE AVERAGE REMOVED *
 *

DATA POINT NO.	OBSERVED AVERAGE EPR(N1)	C.D.S. REFERENCE EPR(N1)	PERCENT EPR(N1) DELTA	OBSERVED S.R.X1000	C.D.S. REFERENCE S.R.X1000	PERCENT S.R. DELTA
1	91.550	92.270	-0.779	37.997	36.317	4.625
223	98.369	99.629	-1.265	30.461	29.035	4.910
224	96.500	97.862	-1.392	33.907	32.067	5.738
225	97.324	98.378	-1.071	35.971	34.610	3.933
231	98.806	99.944	-1.139	29.038	27.754	4.625
232	97.991	99.407	-1.424	30.213	28.360	6.535
2301	96.703	98.022	-1.345	31.653	29.812	6.176
2401	95.299	96.977	-1.731	32.901	30.740	7.028
2402	97.932	98.998	-1.076	30.240	28.665	5.495
2501	95.604	97.151	-1.593	30.792	28.807	6.888
251	97.027	97.898	-0.889	37.114	35.515	4.500
262	96.919	98.249	-1.353	33.082	31.670	4.458
263	94.637	96.023	-1.443	36.826	34.414	7.010
291	97.291	98.956	-1.682	30.506	28.595	6.680
292	96.721	98.532	-1.839	31.208	29.314	6.461
3101	99.472	100.330	-0.855	37.013	35.624	3.898
5302	97.590	99.354	-1.775	35.490	33.171	6.988
5401	95.401	97.294	-1.945	35.385	32.812	7.838
5701	96.898	98.137	-1.262	31.175	29.636	5.190
572	96.869	98.057	-1.211	31.109	29.686	4.794
573	94.509	96.769	-1.828	34.210	31.629	8.161
5802	94.771	95.881	-1.158	33.434	31.834	5.025
5803	96.081	97.475	-1.429	35.257	32.775	7.575
5902	96.923	97.767	-0.863	31.392	29.927	4.894
5903	97.272	98.449	-1.195	30.732	29.181	5.314
6101	98.065	99.372	-1.314	30.852	29.289	5.337
612	96.929	98.293	-1.387	32.191	30.485	5.595
613	95.471	96.968	-1.544	33.910	32.059	5.838
TOTAL DATA POINTS	PERCENT AVERAGE	PERCENT EPR(N1) STD. DEVIATION	DELTA	PERCENT AVERAGE	PERCENT S.R. STD. DEVIATION	DELTA
28	-1.349	0.315		5.758	1.186	

Figure 13

CASCADE REVERSER DRAG ANALYSIS

DEFLECTOR DOOR
REVERSER

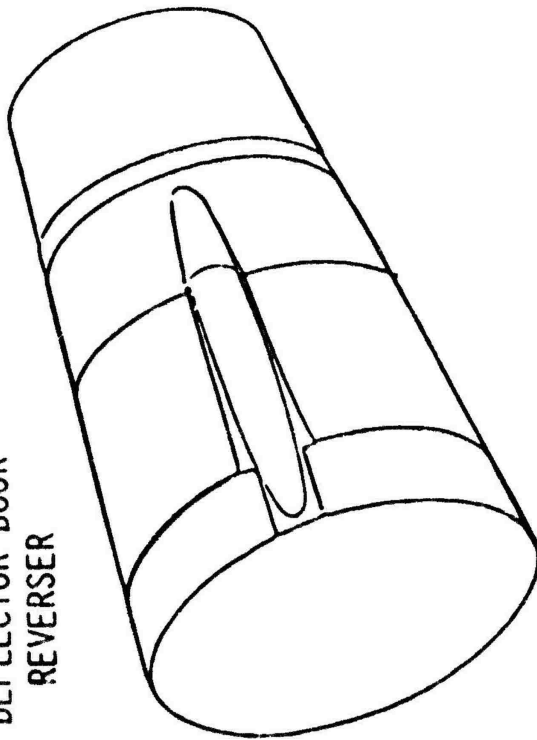

CASCADE
REVERSER

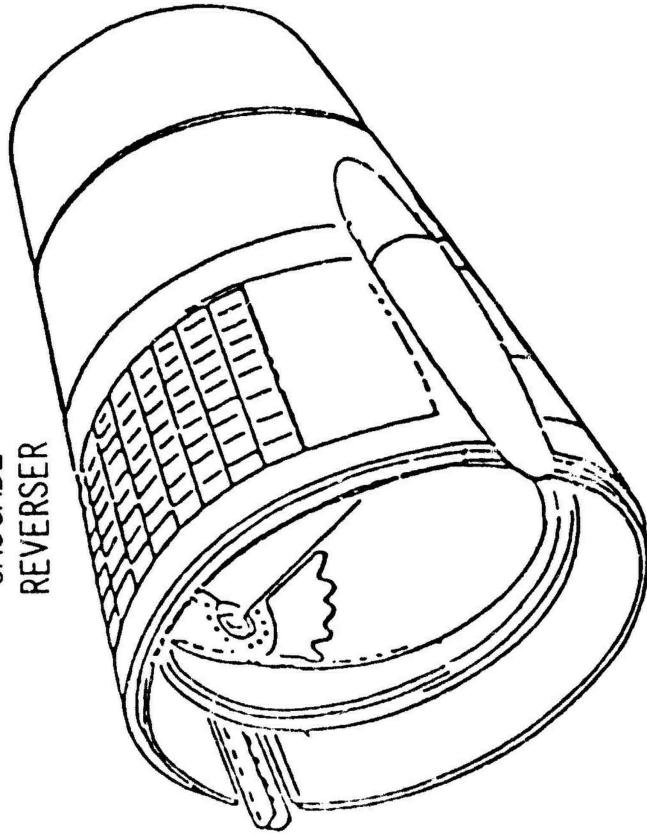

Figure 14

AVERAGE PERCENT DEVIATION FROM
FLIGHT MANUAL STANDARD FOR SPECIFIC RANGE
 (4/77 to 11/79)

	AIRCRAFT NUMBER				OVERALL 72XX	727-100 FLEET (ALL 70XX A/C)
	7260	7261	7262	7263		
MEAN BEFORE	-1.25	-0.88	1.54	-0.69	-0.31	0.08
MEAN AFTER	-0.87	-1.76	-0.61	-1.10	-1.07	-0.07
FLEET Δ MEAN					(.76)	(.15)

Figure 15

COMPARISON OF PERCENT DETERIORATION OF SPECIFIC RANGE
PERFORMANCE BETWEEN 727-100 FLEET AND 72XX AIRCRAFT
BEFORE AND AFTER CASCADE REVERSER INSTALLATION

(4/77 to 11/79)

	"RENO COMMUTER" 72XX FLEET	727-100 FLEET
Δ MEAN	(.76)	(.15)

DIFFERENCE BETWEEN Δ MEANS	STD. ERROR OF THE DIFFERENCE BETWEEN Δ MEANS	PROBABILITY THAT DIFFERENCE IS SIGNIFICANT
0.61	0.098	> 99.999

Figure 16

AIRPLANE PERFORMANCE DETERIORATION

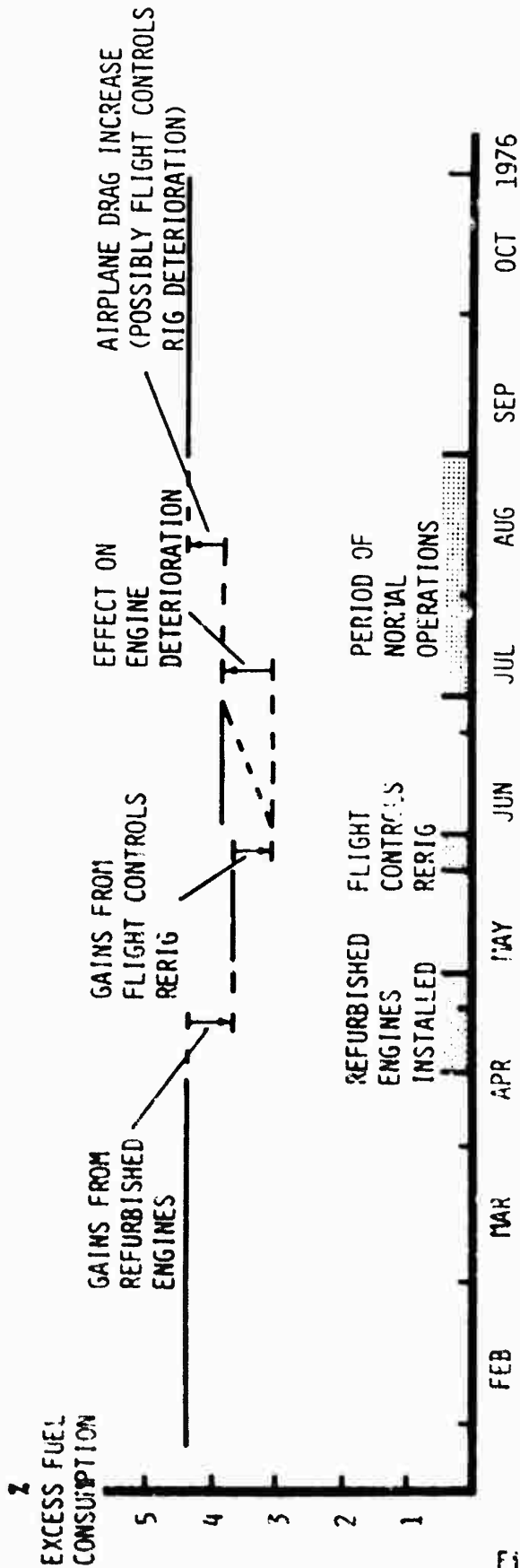

Figure 17

DC-10 FIXED NOZZLE FLIGHT TESTS

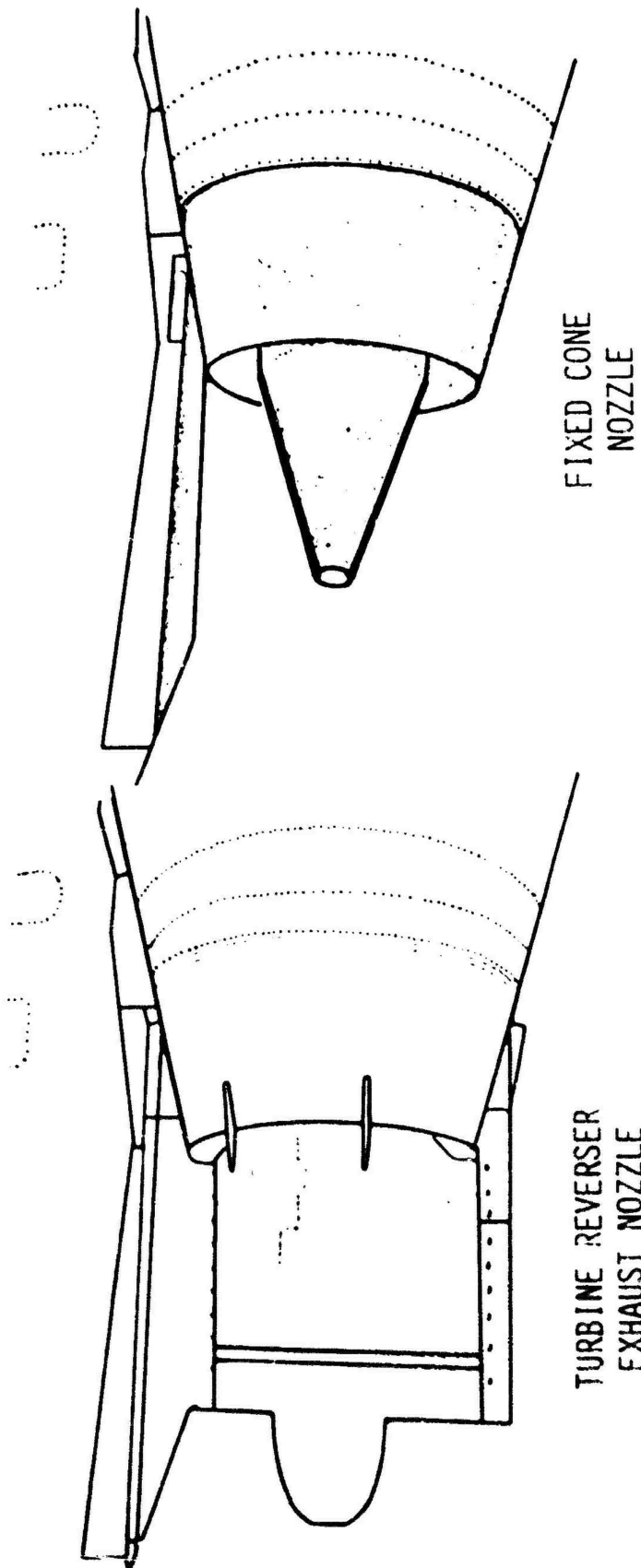

Figure 18

DC-10
VARIATION OF SPECIFIC RANGE WITH AGE
(% OF BASELINE SPECIFIC RANGE)

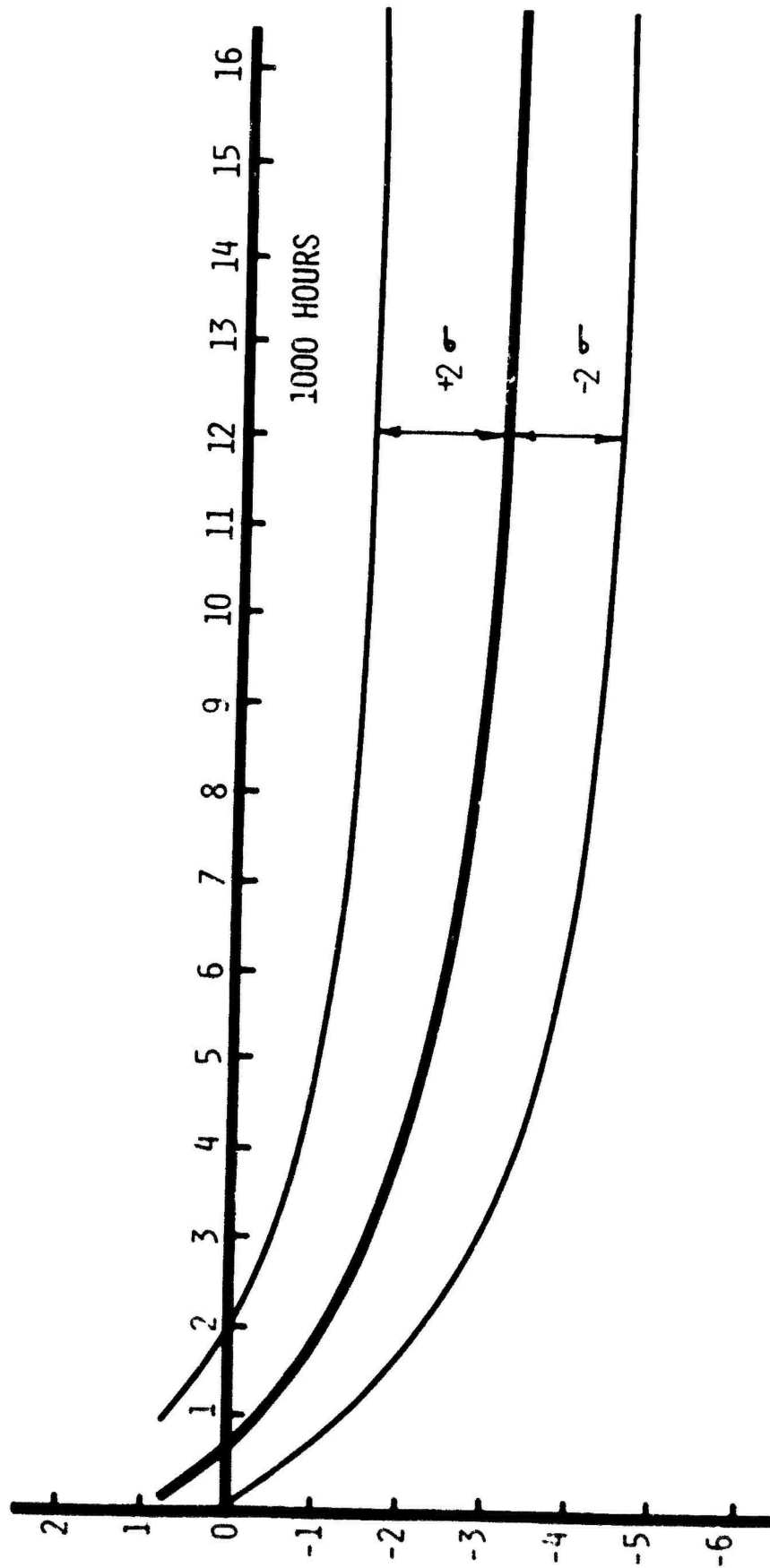

Figure 19

ESTIMATED ENGINE COMPONENT EFFECT ON FUEL CONSUMPTION

Component	Problem	Est. Effect on TSFC
Compressor Stator Vanes	A) Airfoil erosion B) Angle	1-2%
Compressor Blades	A) Chord reduction B) Tip clearance	$\frac{1}{2}$ -1%
Turbine Nozzle Guide Vanes	A) Airfoil bowing B) Airfoil shape C) Platform wear D) Chord	1-2%
Turbine Blades	A) Chord	$\frac{1}{2}$ -1%

Figure 20

APU HOURMETER DATA FLOW

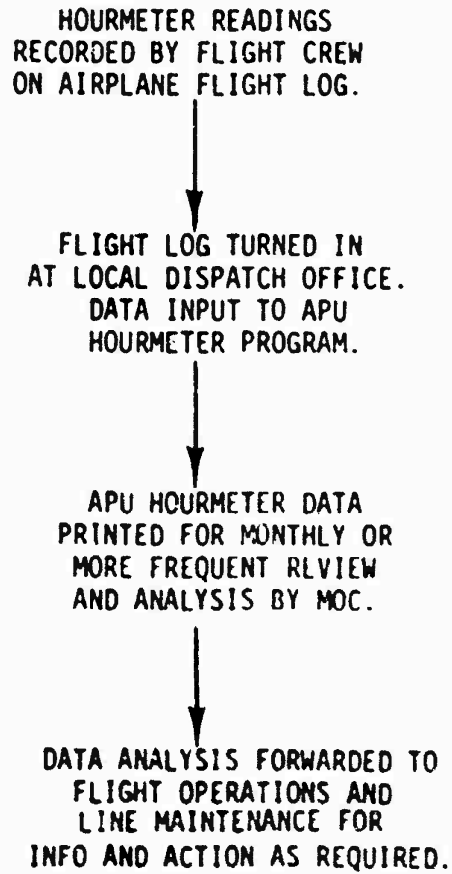

Figure 21

SYSTEM APU FUEL USAGE
MILLIONS OF GALLONS

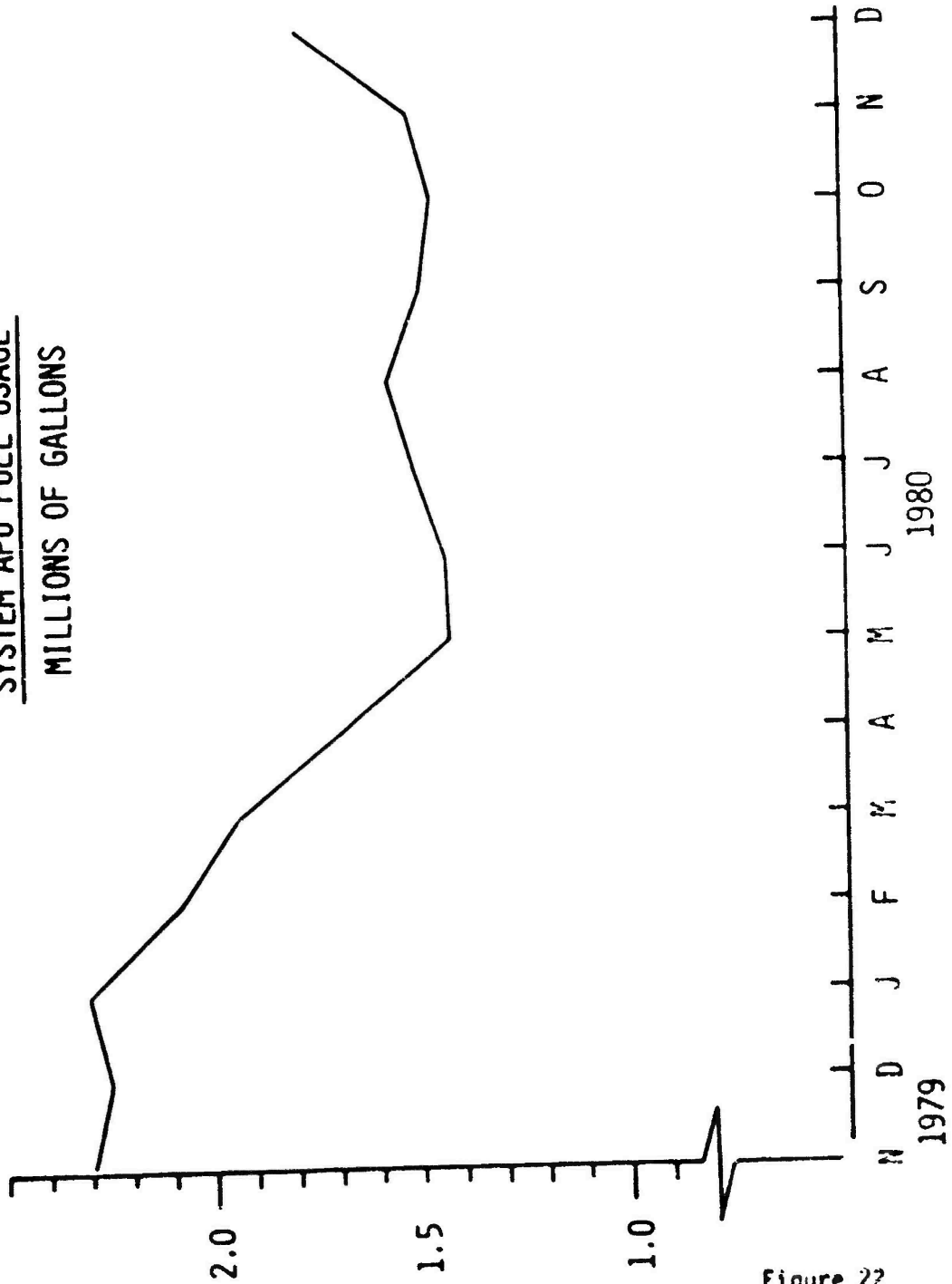

Figure 22

APU FUEL USAGE SAVINGS

12 MONTHS - JANUARY 1980-1981

FLEET	SAVINGS - PERCENT
737	19
727	29
747	19
DC-10	25
AVERAGE	25

Figure 23

SLIDESLIP INDICATION SYSTEM

Dieter Horst
Lufthansa Airlines



1. The Sideslip Story

At the beginning of my presentation I would like to tell you a story about my grandfather telling stories at a time, when I was a child.

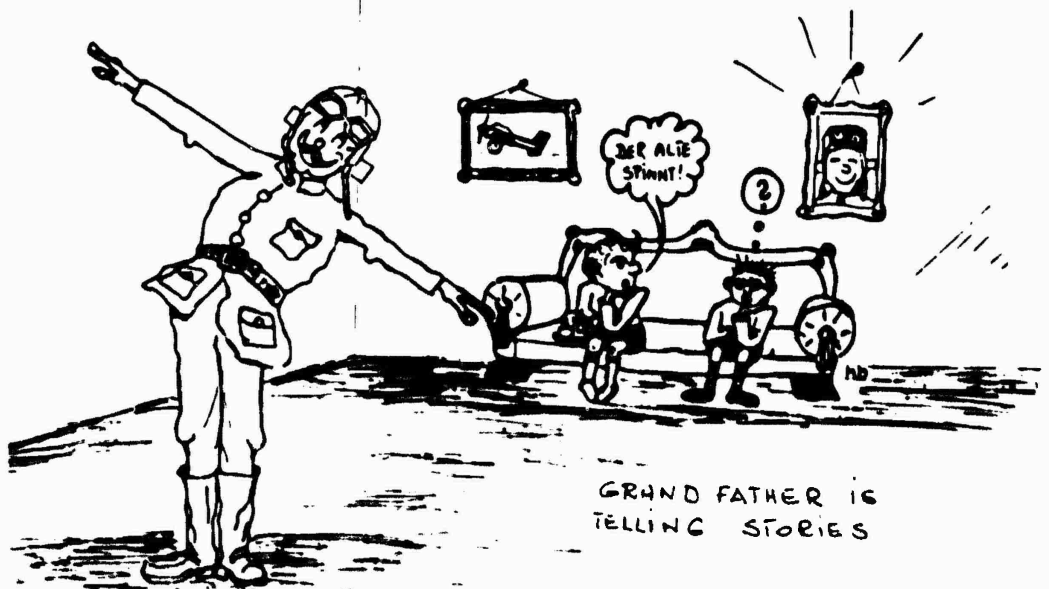

Figure 1

This means the theory I am going to present to you is as old as my grandfather who started flying when flying with airplanes started.

He often used to tell about the poor instrumentation they had in their early airplanes like length of tear drops from their eyes as a speed indication and their scarf as a sideslip indicator.

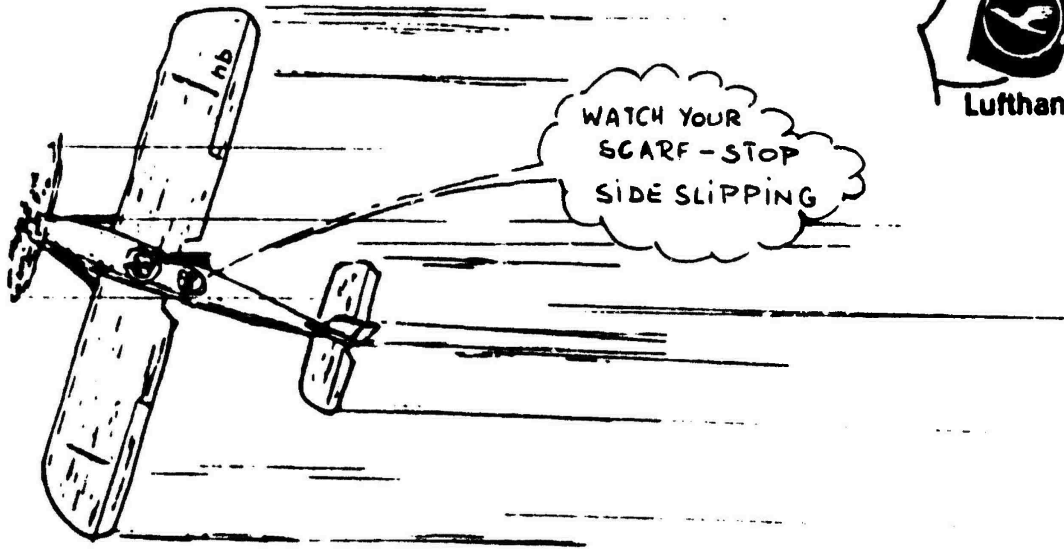

Figure 2

By definition the sideslip angle β is the angle between the longitudinal axis of the airplane's body and the airflow.

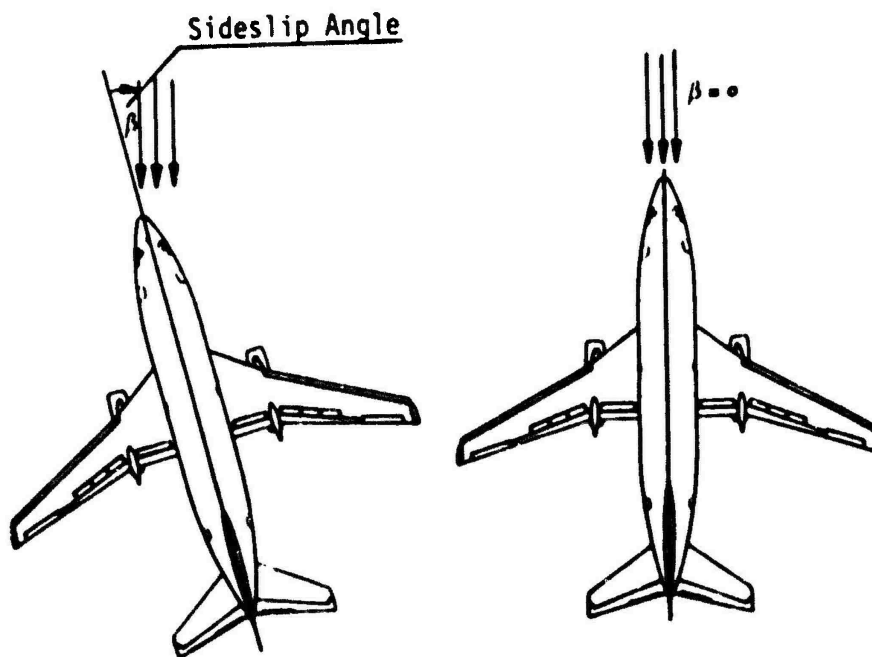

Figure 3

It is certainly that moving an airplane under a certain angle oblique to the airflow does increase its fuel consumption considerably due to body drag and compressibility effects.

Boeing has calculated the following numbers for a fuel burn increase due to one degree of sideslip:



A/C Type	Fuel burn increase due to one degree of sideslip
707	.77 %
727	1.06 %
737	.93 %
747	.75 %

Figure 4

Lufthansa started to think about sideslip in 1976 while working on 737 lateral trim problems.

2. A Little Bit of Flight Mechanics

For many flight mechanic specialists and for the airplane manufacturers, airplanes are always symmetrical from an aerodynamic standpoint which means (provided power readings are symmetrical):

- heading constant
 - wings level
 - sideslip "0"
- } with rudder and aileron trim "0"

This is poor theory!

Airline engineers have to face the facts and it is a fact that most airplanes are either asymmetric in lift/drag or thrust or in both.

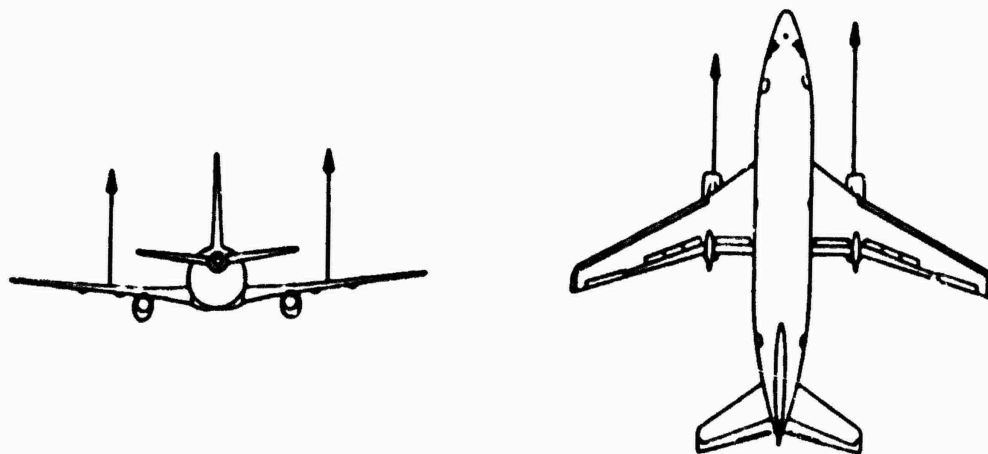

Figure 5



The problem is that:

1. Airplanes have manufacturing tolerances.
2. On our sensitive high performance airplanes flap/slat system rigging can be performed only within certain tolerances. This allows a certain degree of lift asymmetry.
3. N_1 or EPR as a thrust setting parameter does not necessarily guarantee symmetric thrust, as the indication system also has certain tolerances.

In all cases you end up with the following condition:

- aileron trim input \rightarrow wings level
- rudder trim input \rightarrow heading constant
- sideslip \neq "0"

If the pilot applies the trim procedure right he flies with a minimum sideslip angle but there is a certain danger that he enters into a cross trim, when he does not give the airplane sufficient time to stabilize.

Figure 6 shows why this might happen.

The problem is that a rudder or an aileron input always results in a movement around the yaw- and the roll axis and that in flight mechanics there is a relationship between heading, sideslip angle β and roll angle ϕ .

Another point is that an airplane sometimes has different abnormalities which counteract each other and do not show up in a trim requirement, but cause a sideslip of the airplane.

Another reason to have a sideslip indication system is the long period between two airplane overhauls, which depending on the airplane type goes up to 30.000 fh today. Since LH considers one testflight per airplane per year necessary to verify the good aerodynamic quality of the airplane, LH engineering was trying to think of an alternative to avoid the high test flight costs.

So the result of our considerations finally was that a sideslip indication system could save

- fuel
- maintenance cost
- cost for unnecessary test flights.

In this respect the cockpit instrumentation of a modern well equipped present day jet transport is far below the standard at the time of my grandfather flying his biplane and wearing a scarf. Today we do not have a cockpit instrument showing the degree of sideslip.

JOIN IN - SAVE FUEL



OUTPUT

FORCES AND MOMENTS

INPUT

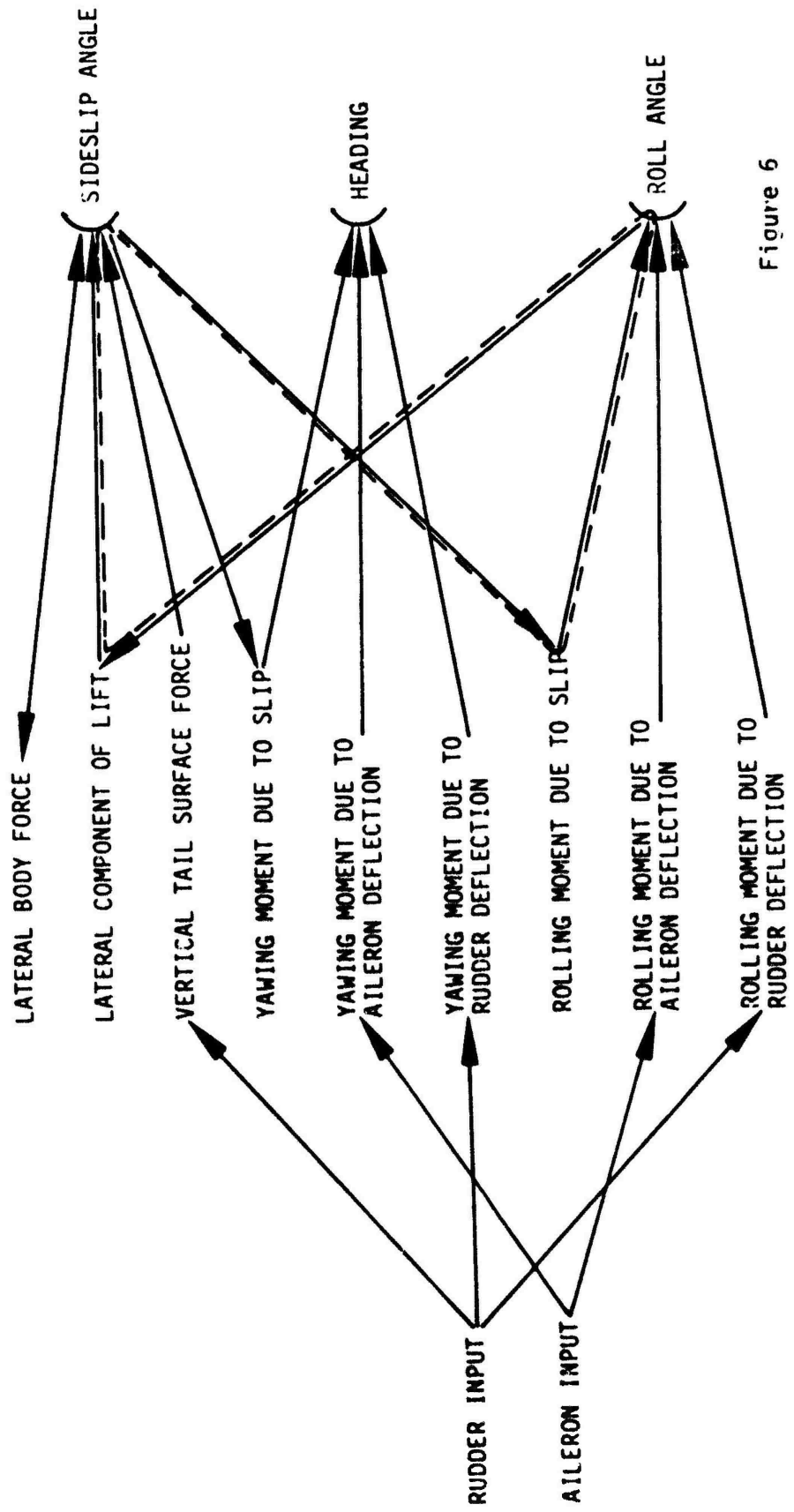

Figure 6

3. Sideslip Indication System Development

Trying to develop a practical solution for a sideslip indication system we remembered the scarf story of my grandfather and the idea of glider pilots (whose thinking and whose technology is always a little bit ahead of time) to glue a woolen thread to the centerline of their canopy as a very sensitive sideslip indicator.



Figure 7

Since a simple solution using a woolen thread is not possible on a modern jet transport, we specified a stall warning vane type sensor and an indicator in the cockpit.

Fortunately LH at that time decided to deactivate the gust response suppression system of the 747-230B SCD airplanes.

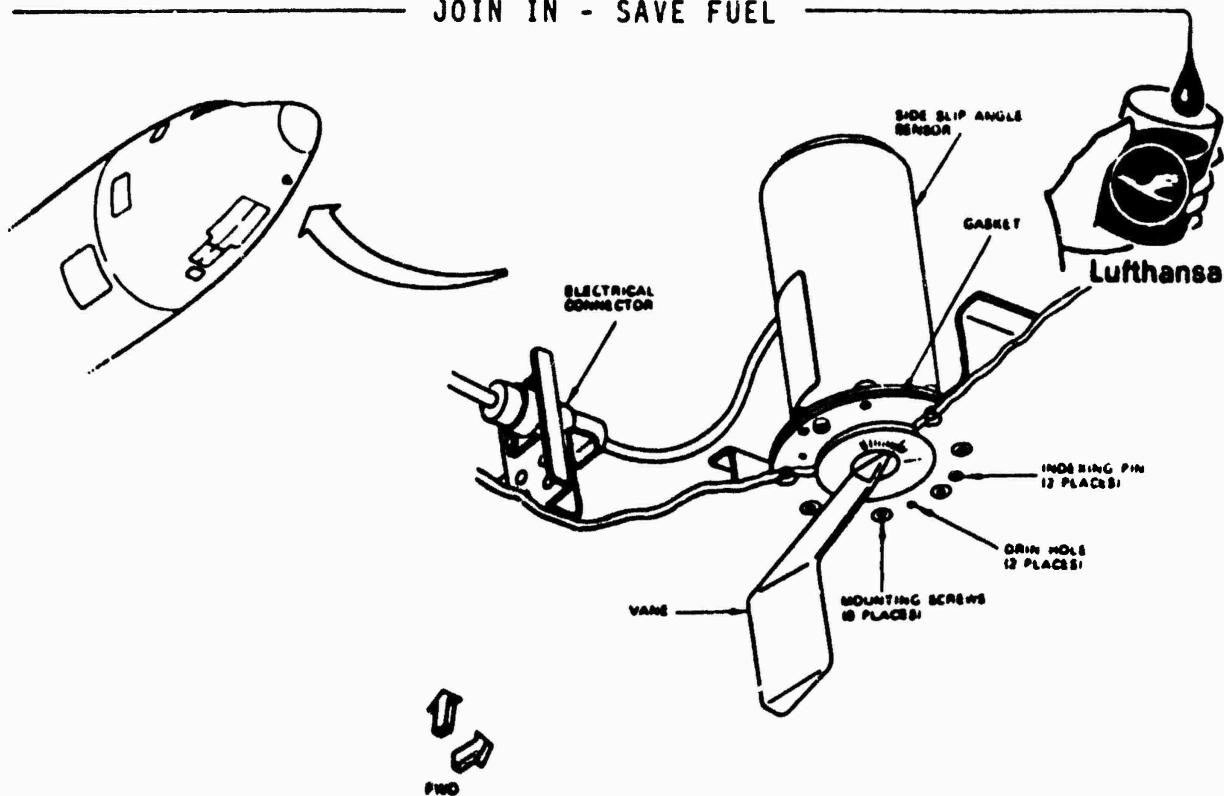

Sideslip-Angle-Sensor Installation

Figure 8

This system consists of a vane type sensor mounted under the nose of the airplane to detect horizontal gust activity and an electronic black box adding gust response suppression signals to the yaw damper activity for passenger comfort reason. As LH is flying cargo on the rear main deck of the airplane, gust response suppression is no longer needed. This gave us the opportunity to connect the gust sensor which, as a matter of fact, is a sideslip sensor to the performance/maintenance recorder to get a feeling for the magnitude of the sideslip angles encountered during flight of a well rigged airplane and for the system accuracy required. The evaluation was conducted with two airplanes. Twenty flights per airplane were recorded.

After computation the following parameters were printed on a line printer:

- GMT
- pressure altitude
- computed airspeed
- magnetic heading
- sideslip angle
- control wheel position
- rudder surface position
- control column position
- pitch trim
- flap position (right inboard)

For the first and last flight hour one reading was printed for each second, for the remaining time four readings were printed after every sixteen seconds of flight time.

Figure 10 shows a typical printout.



The sideslip angle is printed in octal notation and has to be translated into real data by means of a conversion plot. As expected, examination of the printouts revealed that a well rigged 747 with well adjusted thrust and precise indication flies in cruise straight and level for hours without any sideslip. Most of the flights however showed sideslip angles during cruise up to 2 degrees with an accumulation in the area of .3 to .7 degrees probably due to thrust on trim setting tolerances. During climb and descent and during heading change, sideslip angles in excess of five degrees were encountered.

With this knowledge LH in 1979 specified a sideslip indication system for the A310 and the 737-230B airplanes which would meet the following objectives:

- range \pm 5 degrees
- inaccuracy \leq .2 degrees

Airbus Industrie meanwhile has offered a system for the A310 with indication on the CRT but LH has requested a more simple and more economical solution.

Boeing offered a system for 63.000 USD per airplane and a lead time of two years. This system of course could not be accepted due to the high price and the late availability.

Looking for an acceptable, simple system LH finally contacted the German Instrument and Indication System Manufacturer, VDO, and found out that the Teledyne stall warning transmitter fulfills the requirements and can be used as a sideslip sensor.

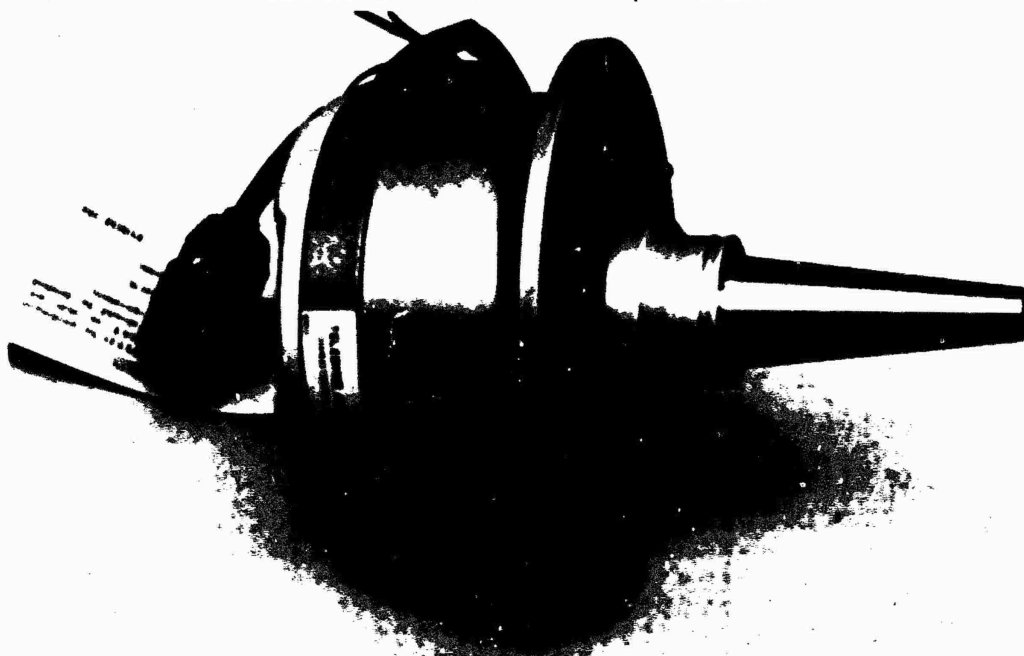

Figure 9

An indicator, slightly modified, could also be made available. The transmitter is a self powered, null seeking internal vane airstream direction sensor.

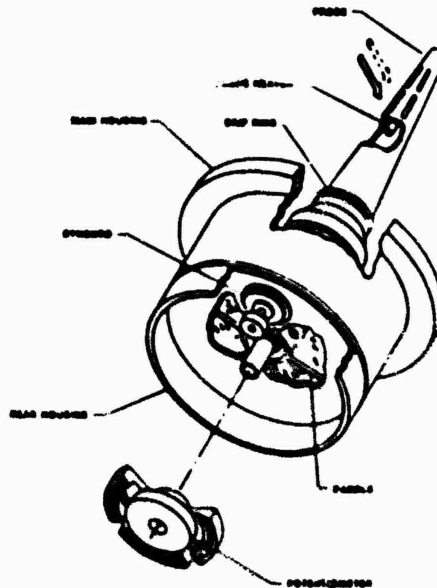

Figure 11

It employs a conical shaped pressure sensing probe which extends through the aircraft fuselage perpendicular to the local air flow. Directly coupled to the probe are a paddle (internal vane) and the electrical output elements. The paddle has two blades and there are two separators in the transmitter housing so that two paddle chambers are formed.

The sensing probe has two pairs of longitudinal slots symmetrically located about the probe center line. When the probe is aligned to the local air flow, the pressure distribution around the probe is symmetrical with respect to the center line and air pressure at each pair of slots is equal. Change in air flow direction shifts the pressure distribution in relation to the center line and causes pressure to increase in one pair of slots and decrease in the other. The unequal pressures are ported to the opposing faces of the paddle blades and resulting force rotates the probe until the pressures are equal; i.e., until the probe has been realigned with the airstream. As the probe rotates, the output elements attached to the probe are also rotated, thus providing electrical signals proportional to the sideslip angle.

The performance of the system which is used as an angle of attack indication system on both commercial and military aircraft is specified as follows:

- sensor range \pm 35 degrees
- indicator range: optional
- system accuracy \pm .2 degrees



During an Intermediate Layover in January 1981 Lufthansa equipped two Airbus A300's with a sideslip sensor to get more information on the magnitude of sideslip angles encountered during normal line operation and on indication system accuracy required.

From wind tunnel tests conducted earlier Airbus Industrie provided the optimum location for sensor installation.

One problem during sensor installation was how to find the airplane's body centerline as precisely as possible since already small deviations would have a significant effect on the sensing accuracy of the probe. LH workshop specialists managed to find the centerline with very high accuracy by taking two fixed points at each fuselage side as a reference and drawing circular arcs by means of a steel band, from there crossing in two places at the bottom of the fuselage.



Figure 12

The line connecting the two crossings is the body centerline. For sensor installation a tool is provided which makes it possible to find the sensor zero position very precisely. Following the outlined procedure, the sensor installation did prove not to be a difficult job.



Figure 13

The sensor's signals were recorded on the airplane's performance/maintenance recorder (PMR) with a frequency of one Hertz.

During 747 measurement evaluation LH found out by experience that printing all the data on a line printer is not practical as this gives you a huge bunch of data impossible to interpret. So LH decided to cooperate with the German Computer and Software Company, Johne and Reilhofer, in Munich to have all the data processed and plotted.



The following parameters were selected from the PMR for computation:

- sideslip angle
- indicated airspeed
- magnetic heading
- altitude
- rudder position
- elevator position
- roll angle
- slat position

Meanwhile fifty out of one hundred flights for which data have been obtained have been evaluated.

The evaluation could not be finalized in time because the probe heater of one of the two sensors available burned out due to operation on the ground.

Probe heater operation on ground is limited to two minutes. To avoid heating of the probe on ground the system was connected to the main landing gear air-ground sensor so that it will be activated only during flight.

The reason why the probe heater finally burned out was maintenance personnel manually operating the air-ground switch into the air mode without pulling the circuit breaker for the heater.

So the first important result of our testing was the realization that a series probe heater must have a thermal switch to avoid burning out the heating element.

To our knowledge such a modified sensor is already available, but up to now it has only a military certification.

4. Data Processing and Data Analysis

As already mentioned, processing and plotting of the data was done by Johne and Keilhofer Software Company in Munich. The first tape sent to Munich for computation consisted of 23 flights each of about one hour of duration. For every flight Lufthansa gets plots plus additional line printouts (figure 14 to 17). For each tape LH gets a summarizing computation (figure 18). The anticipated four summarizing computations will again be summarized at the end of all data processing.

Figure 14 shows a combined time plot of all parameters computed.

Figure 15 is a classification plot showing the time of sideslip for each sideslip angle range of .2 degrees. During this flight the airplane flew about 300 seconds of the total flight time of 1008 seconds in a sideslip angle of class-1 equivalent to the range of .12 to .32 degrees left (minus is left, plus is right).



Figure 16 shows the whole classification for a range from minus 5 degrees to plus 5 degrees in steps of .2 degrees.

Figure 17 is a plot showing how many percent of the total cruise flight time the airplane was flying in a certain sideslip angle condition with a certain speed.

Figure 18 gives a summary of the first 23 flights computed. Figure 19 shows the corresponding plot.

As only sideslip angles during cruise flight (from slats up to slats down) were considered to be relevant, all flight time associated with more than seven degrees of roll angle was suppressed. By this definition 12 hours 39 minutes 12 seconds of the total test flight time of 15 hours 12 minutes 4 seconds is the total cruise flight time. The figure again shows the total time of sideslip in the different angle ranges during cruise. During a period of 4 hours 3 minutes 47 seconds, equivalent to 32.11 percent of the total flight time the airplane flew with sideslip angles in the range between minus .52 to minus .72 degrees (left).

5. Consequence of Lufthansa Measurement Results and Further Proceedings

As it turns out, the sideslip angle of the Airbus A300 is about equivalent to fuel burn increase in percent. Since avoiding the sideslip angles recorded with our well rigged well maintained airplanes would already save about .2 percent of fuel burned during the defined cruise flight, probably a higher saving is inherent in avoiding sideslip angles on older, or less maintained, or from the aerodynamic standpoint, more sensitive airplanes. It must be mentioned that the drag increase due to sideslip is relatively small at small sideslip angles but increases rapidly with increasing sideslip angle.

In addition a sideslip indication system helps to detect hidden abnormalities causing sideslip of the airplane.

Based on this knowledge Lufthansa meanwhile has confirmed the earlier specification of the A310 sideslip indication system and has added the sideslip information to the A310 aircraft integrated data system (AIDS).

The A310 performance analysis based on AIDS readouts will be the first analysis taking sideslip angles into consideration. LH feels that part of the variation noticed in today's performance analysis can be attributed to sideslip.



A 300 sideslip measurement analysis

Figure 14: Time plot of all parameters computed

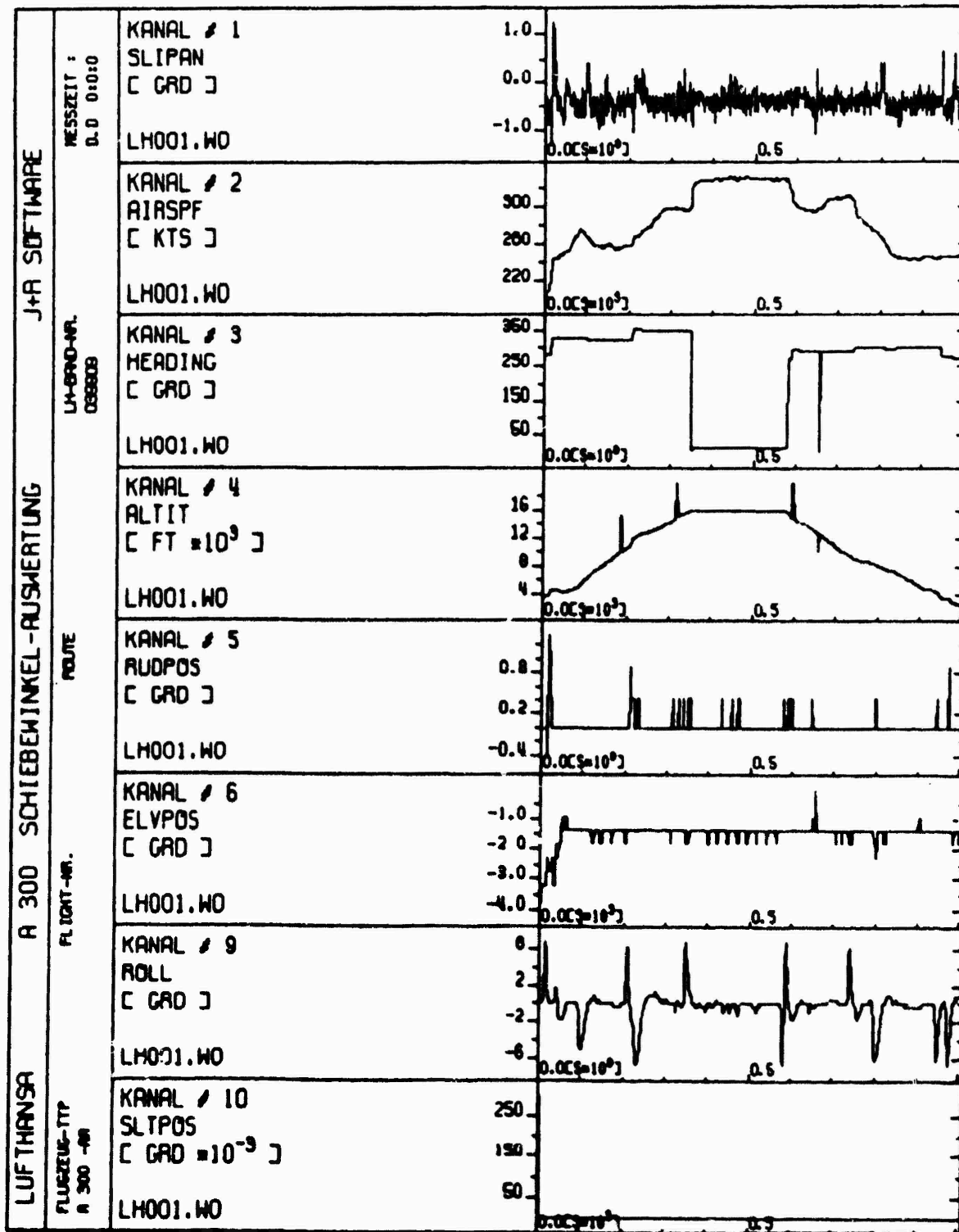

JOIN IN - SAVE FUEL

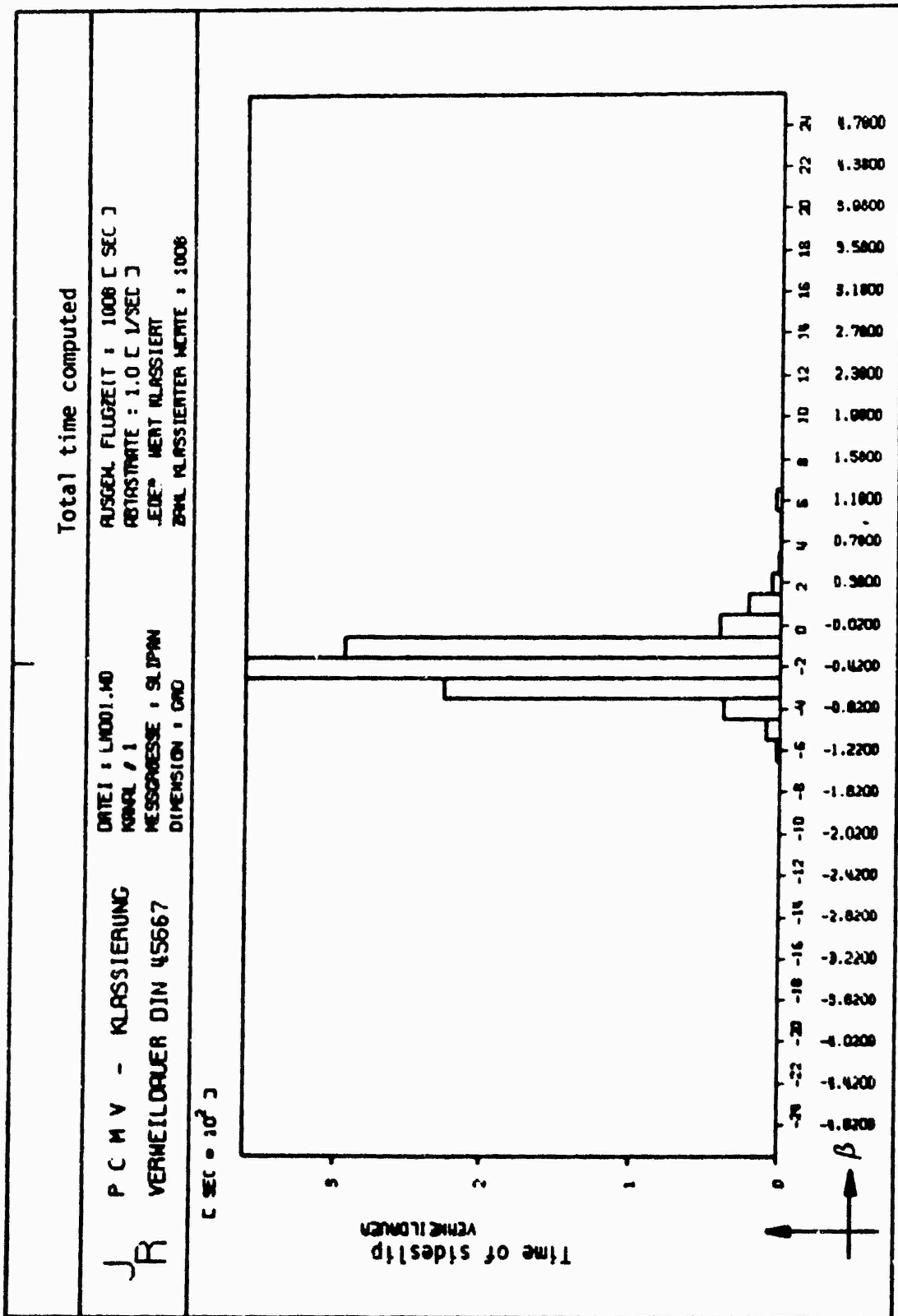

A 300 sideslip measurement analysis

Figure 15: Classification plot

A 300 sideslip measurement analysis

Figure 16: Classification in steps of .2 degrees
(Range ± 5 degrees of sideslip angle)



LH-Bandnummer : 039909
 Gesamtflugzeit : 1316 [s]
 Ausgew. Flugzeit : 1008 [s]
 Abtastrate : 1 000 [1/s]
 Anzahl klass. Werte : 1008
 Es wurde jeder : 1 Wert klassiert
 Klassenanzahl : 51
 Klassenbreite : 2000
 Nullpunktstand : -25.60

VERWEILDAUER : DIN 45667
 DATEINAME : LH001.W0
 SLIPAN : [ORD]

Klasse #	Klassenmitte	Unterer Rand	Oberer Rand	Verweildauer [s]	Rel. V-dauer %
-25	-5 020	-5 120	-4 920	0000	0000
-24	-4 820	-4 920	-4 720	0000	0000
-23	-4 620	-4 720	-4 520	0000	0000
-22	-4 420	-4 520	-4 320	0000	0000
-21	-4 220	-4 320	-4 120	0000	0000
-20	-4 020	-4 120	-3 920	0000	0000
-19	-3 820	-3 920	-3 720	0000	0000
-18	-3 620	-3 720	-3 520	0000	0000
-17	-3 420	-3 520	-3 320	0000	0000
-16	-3 220	-3 320	-3 120	0000	0000
-15	-3 020	-3 120	-2 920	0000	0000
-14	-2 820	-2 920	-2 720	0000	0000
-13	-2 620	-2 720	-2 520	0000	0000
-12	-2 420	-2 520	-2 320	0000	0000
-11	-2 220	-2 320	-2 120	0000	0000
-10	-2 020	-2 120	-1 920	0000	0000
-9	-1 820	-1 920	-1 720	0000	0000
-8	-1 620	-1 720	-1 520	0000	0000
-7	-1 420	-1 520	-1 320	0000	0000
-6	-1 220	-1 320	-1 120	2 000	1984
-5	-1 020	-1 120	-9200	9 000	8929
-4	-8200	-9200	-7200	39 00	3 869
-3	-6200	-7200	-5200	226 0	22 42
-2	-4200	-5200	-3200	360 0	35 71
-1	-2200	-3200	-1200	293 0	29 07
0	-2000E-01	-1200	8000E-01	41 00	4 067
1	1800	8000E-01	2800	22 00	2 183
2	3800	2800	4800	7 000	6944
3	5800	4800	6800	3 000	2976
4	7800	6800	8800	1 000	9921E-01
5	9800	8800	1 080	1 000	9921E-01
6	1 180	1 080	1 280	4 000	3968
7	1 380	1 280	1 480	0000	0000
8	1 580	1 480	1 680	0000	0000
9	1 780	1 680	1 880	0000	0000
10	1 980	1 880	2 080	0000	0000
11	2 180	2 080	2 280	0000	0000
12	2 380	2 280	2 480	0000	0000
13	2 580	2 480	2 680	0000	0000
14	2 780	2 680	2 880	0000	0000
15	2 980	2 880	3 080	0000	0000
16	3 180	3 080	3 280	0000	0000
17	3 380	3 280	3 480	0000	0000
18	3 580	3 480	3 680	0000	0000
19	3 780	3 680	3 880	0000	0000
20	3 980	3 880	4 080	0000	0000
21	4 180	4 080	4 280	0000	0000
22	4 380	4 280	4 480	0000	0000
23	4 580	4 480	4 680	0000	0000
24	4 780	4 680	4 880	0000	0000
25	4 980	4 880	5 080	0000	0000

A 300 sideslip measurement analysis

Figure 17: Time - sideslip angle - speed relationship

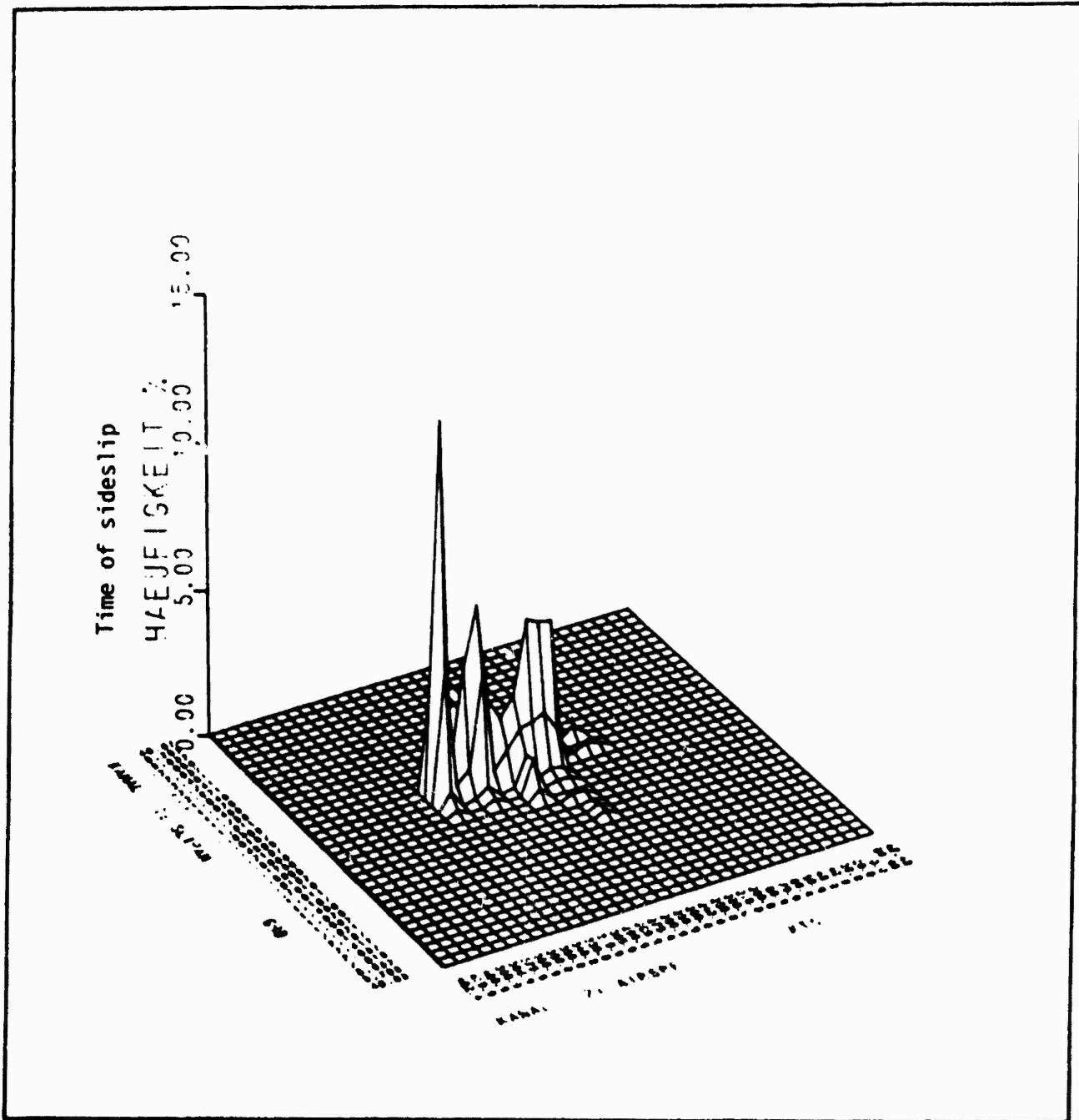



Figure 18: A300 Sideslip measurement analysis

Summary

Number of flights : 23
 Total test flight time : 54724 sec = 15 h 12 min 4 sec
 Total cruise flight time: 45552 sec = 12 h 39 min 12 sec

	Sideslip Angle Range Degrees	Total Time of sideslip recorded during cruiseflight			
		h	min	sec	%
-14	-2,92 / -2,72			7	0,02
-13	-2,72 / -2,52			8	0,02
-12	-2,52 / -2,32			16	0,04
-11	-2,32 / -2,12			14	0,03
-10	-2,12 / -1,92			36	0,08
- 9	-1,92 / -1,72		1	07	0,15
- 8	-1,72 / -1,52		1	45	0,23
- 7	-1,52 / -1,32		2	15	0,30
- 6	-1,32 / -1,12		5	51	0,77
- 5	-1,12 / -0,92		18	53	2,49
- 4	-0,92 / -0,72	1	5	35	8,64
- 3	-0,72 / -0,52	4	3	47	32,11
- 2	-0,52 / -0,32	4	35	51	36,33
- 1	-0,32 / -0,12	2	0	51	15,92
0	-0,12 / 0,08		10	9	1,34
1	0,08 / 0,28		4	27	0,59
2	0,28 / 0,48		1	57	0,26
3	0,48 / 0,68		1	33	0,20
4	0,68 / 0,88		1	21	0,18
5	0,88 / 1,08			41	0,09
6	1,08 / 1,28			29	0,06
7	1,28 / 1,48			13	0,03

JOIN IN - SAVE FUEL

TOTAL CRUISE
FLIGHT TIME IN:
% SEC.

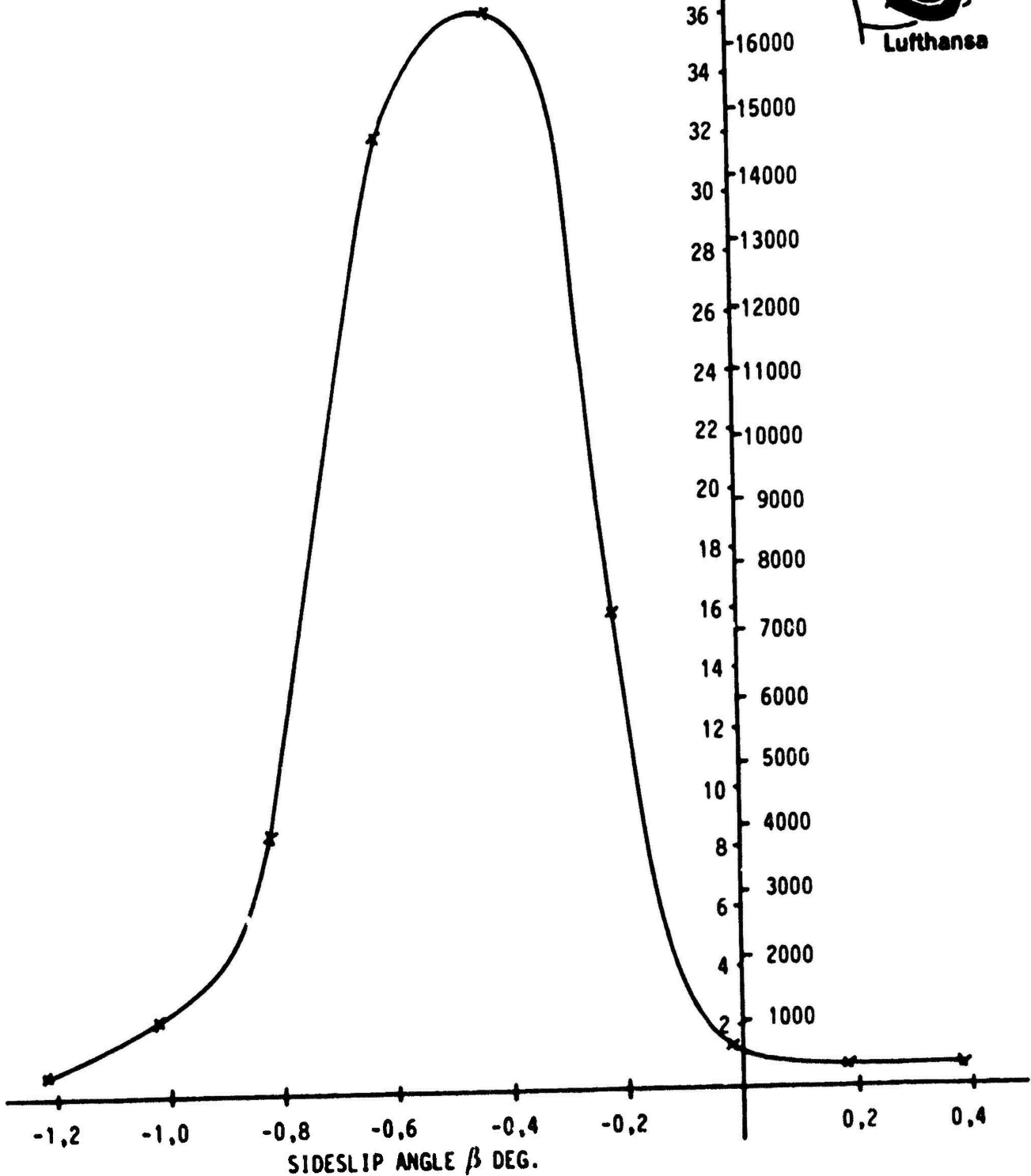

Number of flights summarized: 23
Total testflight time : 54724 sec = 15hrs 12min 4sec
Total cruiseflight time: 45552 sec = 12hrs 39min 12sec

Figure 19 : A-300 sideslip angle measurements

In addition Lufthansa is thinking of feeding the sideslip signal into the A310 flight management system, giving preference to avoiding sideslip by asymmetric thrust, then by lateral trim inputs. On an airplane being not ideally symmetrical in thrust and /or lift/drag this of course will lead to a certain constant bank angle. It has to be verified by calculation that this procedure leads to minimum fuel burn.



We hope that we can finish this work in time to specify certain requirements for the flight management system on our future A310's.

Everyone in the audience is invited to join us in our work and in convincing indication system seller and all the reluctant airplane manufacturers to provide a system which will help make your airplane a piggy bank (Figure 20).

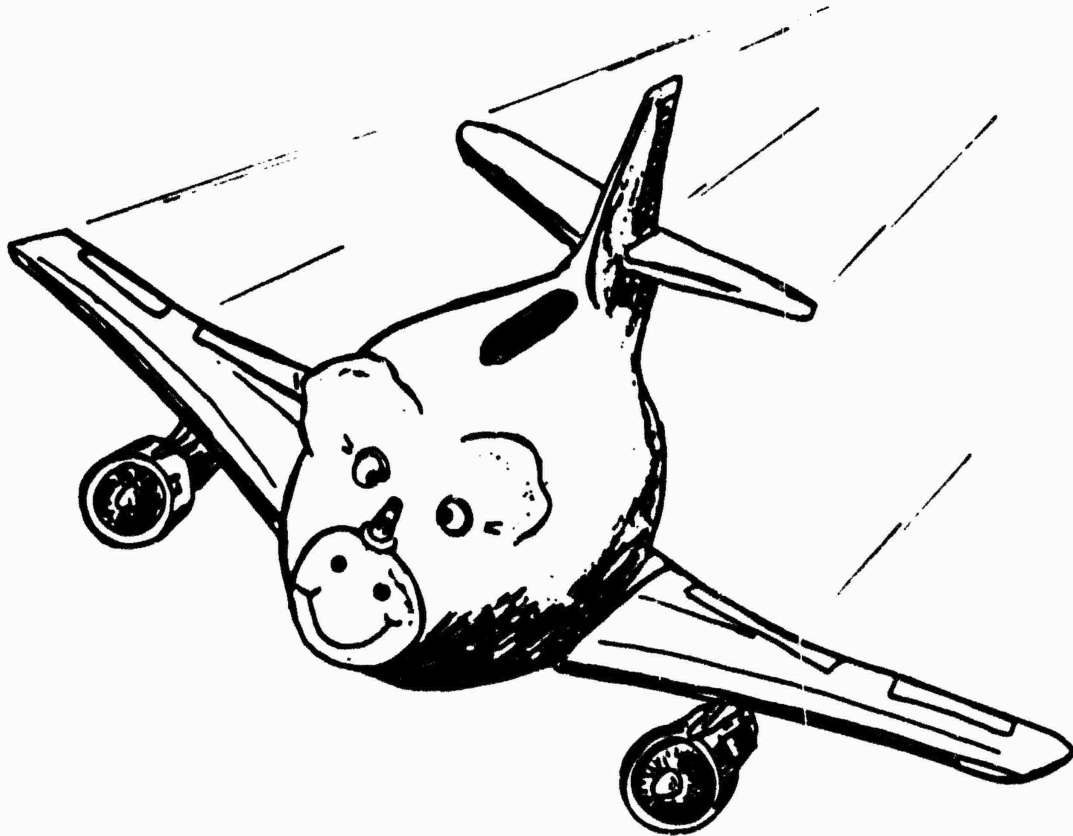

Figure 20

TURBINE ENGINE FUEL CONSERVATION
BY
FAN AND COMPRESSOR PROFILE CONTROL

BY

William B. Roberts
Flow Application Research
Fremont, California 94538

and

William Rogers
Rogers-Dierks, Inc.
San Pedro, California 90731

TURBINE ENGINE FUEL CONSERVATION
BY
FAN AND COMPRESSOR BLADE PROFILE CONTROL

Introduction

As fuel becomes the dominant airline operating cost, it is increasingly important to conserve as much as possible during routine aircraft operation. A consistent savings of between $\frac{1}{2}$ to 1 percent can mean the difference between profit and loss for many air carriers.

One method which can provide this order of fuel savings is the control of the fan and compressor blade shapes. As an engine wears in service, the blade shapes become distorted due to erosion. This causes an aerodynamic performance deterioration which increases fuel consumption. At the time of refurbishment, if new blades that are within specification are used, fuel consumption is again lowered to near-new engine values; however, it is often impossible to use totally new blades, and certainly parts are less costly if reconditioned blades are used. Reconditioned blades that have been sorted, reshaped and matched allow a superior recovery of fuel efficiency without the need for new blades. Furthermore, new blades, upon being put into service, can greatly benefit from being sorted, reshaped, and matched to allow full performance potential to be realized. The blade where this is the most critical is the first stage fan blade, since it operates in a high erosion environment at supercritical aerodynamic conditions, while consuming more power than any other single blade.

Cell tests done during this study have shown that fan and compressor blade shape control can lower fuel burn as much as 2-2 $\frac{1}{2}$ % compared to standard refurbishment. This could lead to a significant fuel savings if implemented on a fleet-wide basis. Data used in the following discussion to verify this improvement pertains to the Pratt and Whitney JT8D series of engines (see Figure 1). It is expected that all aviation gas turbine engines would benefit from fan and compressor blade profile control.

Profile Control Apparatus

A sample blade is held in a cradle while a stylus is moved across the profile at any selected spanwise position. The stylus is driven by a servomotor controlled by a Hewlett-Packard 9825 microprocessor. The microprocessor then compares the motion of the stylus to that it would have across an ideal section at that spanwise location and computes the discrepancies, if any, for several chord-wise stations. Each profile is divided into ten equally-spaced stations, as shown in Figure 2. An abbreviated example of an inspection specification for HP compressor blades is given in Table 1.

After inspection, the blades fall into three categories: (1) within specified tolerances; (2) reworkable; and (3) reject. Category 1 blades are peened, cleaned, finished and varnished. Category 2 blades are those that are out of tolerance, but have enough material to benefit from rework. They are held in a cutting device controlled by a Hewlett-Packard 9825 microprocessor where the leading edge is restored to a specified radius and contour near to ideal. Finally, the trailing edge is reformed, if necessary, to specification in a die. These blades are then finished in the same manner as for Category 1. Category 3 blades are both out of specification and lack sufficient material for leading and/or trailing edge restoration. They are scrapped.

High Pressure Compressor

All airline power plant engineers are well aware of the differences in shape of high time, high pressure (HP) compressor blades. Most often, leading edges have been blunted by erosion and trailing edges have been excessively sharpened. Also, by the wearing effect of erosion, different blade rows show different wear patterns and, indeed, from engine to engine there can be variations in wear patterns between the same blade row. What is less well-known is the large variation that can occur among new blades for the same blade row in the HP compressor. The blades pictured on Figures 3 through 5 specifically show that there are considerable differences in dimensions of new blades that have approximately the same chord width. These blades were taken from a random sample of new blades from Western Airlines' inventory. These figures show that new blades for the same blade row vary greatly in thickness, leading edge shape, and trailing edge shape. Figure 6 shows the different types of new blade leading edge variations and Figure 7 shows the variation in trailing edge geometry that has been observed for new blades of the same sample. The flow through such irregular blade rows will certainly be less efficient than for those of regular shape.

Leading edges can be reworked by the selected removal of material to fall within the specifications for radius and contour, as is shown in Figure 8. The blades with trailing edge variations are made uniform with a tolerance $\pm 1^\circ$ by striking with a reforming die.

To estimate the effect of leading edge rework, the cascade flow was calculated using a subsonic potential flow code for an outboard blade section from the tenth row of the HP compressor. Results of this flow calculation are shown in Figure 9. The blade at the top of the graph is a statistically average shape for a new tenth-stage profile for a section near the tip. This shape has been verified to be near the ideal blade shape. To the right of the top profile is the pressure distribution around the blade starting on the pressure surface. The flow angles shown are for nominal cruise conditions. As can be seen, the suction surface pressure distribution is typical of a blade operating in the low loss portion of its operating range. The second profile down shows a typical high time blunt leading edge blade from the same location. The bluntness of the leading edge increases the effective incidence to the suction surface causing a large velocity peak near the leading edge. This velocity peak would lead to the separation of the boundary layer, causing a high loss flow situation when compared to the flow around the

statistically average shape above. This boundary layer separation leads to a greatly increased thickness of the boundary layer at the trailing edge, causing high pressure losses and lower efficiency. It also leads to a decrease in the flow deflection through the cascade, which implies a decrease pressure ratio. Therefore, the effect of the flow separation is compounded.

The third cascade flow calculation, shown at the bottom of Figure 9, is of the flow around a blade with a re-contoured leading edge. In this situation, the leading edge is not the same as that of the statistically average blade; however, it is within the specified tolerance for radius and contour. The calculated flow over the cascade of re-contoured blades indicates that the pressure distribution, although not the same as that for the statistically average shape, is very similar and will lead to similar performance. The high velocity peak at the leading edge has been avoided and the flow will remain attached to the blade. This would restore most or all of the performance that was lost due to the bluntness of the leading edge in the second situation.

These calculations were done with a potential flow code that did not include the effects of the boundary layer or of blade-to-blade irregularities; however, it is obvious from the results that the boundary layer would behave much better for the first and third situations than it would for the second situation with the blunt leading edge. Furthermore, at this time, it is not possible to calculate the flow through cascades of irregular blades.

If the cascade flow calculations are correct indicators, then HP compressors refurbished with shape-controlled blades should perform better than those compressors using standard acceptable new or used blades. This hypothesis could be verified by conducting a series of tests on refurbished JT8D engines, the only difference being the blades of the HP compressor. Unfortunately, this is easier said than done, due to the airline industry's immediate need for refurbished engines. Several tests have been done since 1978, however, that indicate rigorous profile shape control can be quite beneficial. Three of these have been chosen as examples.

The first was done by Continental Airlines to determine the operational difference of new blades meeting shape specification versus a random mix of new blades. Two groups of new JT8D high compressor blades were selected. One set of blades was sorted to meet the specified profile requirements; the other group of blades, to be used as baseline for comparison, consisted of a mix with normal production run profile deviations. The two high compressors were then compared in a back-to-back test. Figure 10 shows that the engine with the shape-specified blades has an improvement in Thrust Specific Fuel Consumption (TSFC) of 0.8% at takeoff and 0.6% at cruise, over the baseline engine; all other performance being equal.

The second test was done by TWA to determine if JT8D high compressor blades, considered to be scrap by current chord width measurements, can be reclaimed by rework to contour specifications. Although this test was not back-to-back, it is very interesting in that it compared the performance of a high compressor with all blades re-profiled from short chord rejects to the TWA typical baseline engine. Figure 11 shows that the engine performed near to Pratt and Whitney new production engines. This, in most cases, is better than the TWA baseline after refurbishment.

Finally, a Republic/Air West engine was tested back-to-back to determine if the performance of a marginal engine could be recovered by the substitution of a complete matched set of profile-controlled high compressor blades. The engine used for this test was originally a JT8D-7, which had been converted to a -15 a year earlier. A few flight cycles after a shop visit, where little or no improvement was achieved, the engine was returned to the overhaul facility for warranty repair. After a pre-overhaul test, the engine was refitted with a complete matched set of high compressor blades which met profile specifications. The only other change was the replacement of two stator rows that had structural cracks; however, no performance change can be attributed to the new stators. After reassembly and testing, it was found that engine EGT improvement at takeoff conditions was 13°C with a corresponding observed improvement in TSFC of approximately 3%. This improvement in fuel consumption was nearly constant over the entire range of operation of this engine, as is shown in Figure 12.

These tests, by themselves, are not definitive proof of the value of rigorous shape control of high pressure compressor profiles; however, they do give a strong indication of their benefit. On the whole, by profile shape management in the HP compressor, we can expect to save an additional 1% in fuel burn over the life of the engine.

The Fan

The same observations that were made for new and high time HP compressor blades can also be made for fan blades, especially first stage fan blades. Not only do high time fan blades differ greatly in the shape of the leading and trailing edges, maximum thickness, and contour distribution, but also new and refurbished blades differ greatly in these geometrical parameters. Figure 13 shows five refurbished first stage fan blades. The blade at the top is near the specified shape, while the four below are well out of tolerance. It can be seen that the shapes vary so much that one would question if these blades were for the same type of engine. Not only were they for the same type of engine, they were weighed and layed for the same rotor disk on the same engine. These blades were refurbished by current shop procedures and were judged acceptable as replacement parts on production engines.

The flow distortions caused by such diverse shapes are very significant due to the nature of the flow into the first stage fan. This blade operates in the transonic region from the part-span shroud out to the tip. The tip Mach number is approximately 1.6 at cruise settings. In this region, such irregularities as bluntness, thickness differences, and leading edge shape differences, can cause significant differences in the blade-to-blade flow.

The increase in losses and the decrease in efficiency due to the bluntness has been documented by NASA personnel at the Lewis Research Laboratory. In 1973, Reid and Ursek* reported on tests done with a research fan which had the leading edge cut back, as is shown in Figure 14. These tests indicate

* Reid, L., and Ursek, D. C., "Experimental Evaluation of the Effects of a Blunt Leading Edge on the Performance of a Transonic Rotor". AMSE J. of Engineering for Power, Vol. 95, Ser. A, No. 3, July 1973.

that the increased leading edge thickness resulted in a decrease in rotor peak efficiency of 3.5% at design speed, accompanied by a decrease in flow capacity of approximately 3%. The loss of efficiency and capacity was attributed to an increase in suction surface incidence angle and an increase in relative total pressure loss due to a stronger bow wave shock system. Partial results from this testing is shown in Figure 15. Thus, it is seen that an increase in leading edge bluntness can have a strong adverse effect on fan performance. This is especially serious in most fan jet engines, since the fan blade or blades absorb a large share of the power produced. In the case of the JT8D, that portion of the first blade outboard of the shroud absorbs almost 10% of the total power produced by the turbines. In aircraft gas turbine engines of higher bypass ratio than the JT8D, such as the JT9, the CF6, or the RB211, the large fan blade is by far the single most critical compressor component of the engine with respect to efficiency and fuel savings, since it alone can absorb over 30% of the power produced.

Figure 16 is a schematic of a relatively simple fan blade modification that can decrease JT8D TSFC by -1.5%. This "chisel" cut is simply a wedge shape cut along the suction surface at the leading edges of refurbished first stage fan blades. Figure 17 shows several TWA tests that indicate that engines with chisel cut fan blades have 1.5% less TSFC than do refurbished engines without the cut. This is a good example of the sensitivity of this area to blade shape.

During this testing, fan pressure ratio was measured to determine the performance difference, if any, between the chisel cut and regular refurbished fans. This was done by the use of a fan duct probe, shown in Figure 18, that was supplied to TWA by the authors. The test cell results show that fan pressure ratio and overall thrust are quite similar for both engines, but that TSFC and EPR (Engine Pressure Ratio) differ significantly. The difference in TSFC indicates that the chisel cut fans are operating more efficiently than the regular fans. The difference in EPR indicates that the mass flow, and therefore thrust, is down through the regular fans and this deficit must be made up by an increase in core thrust; hence, the increase in EPR.

If a simple modification like the chisel cut can produce such significant results, what might happen if a completely matched set of profile-controlled blades were used? The answer could be found from a series of back-to-back cell tests where the only difference is in the blades used for the first stage fan. The anticipated savings of a program of first and second stage fan blade profile control are on the order of 1-1½% of TSFC, compared to current engine rebuild.

Conclusion

JT8D cell tests indicate that a savings of -1% in TSFC for the HP compressor and 1-1½% TSFC for the fan may be possible using blade profile control. If further back-to-back testing shows these levels of savings, this would be a strong incentive to spend the extra time and funds necessary to control profile shape to a close tolerance.

Acknowledgement

The authors wish to thank Timothy Horvatic of Continental Airlines, James Bushey of TransWorld Airlines, Monte Varah of Republic/Airwest Airlines, Robert Lay of Pacific Southwest Airlines, and Western Airlines for the use of the test data in this paper.

TABLE 1

BLADE INSPECTION SPECIFICATION RD-305 FOR JT8D HIGH COMPRESSOR BLADES

I. GENERAL

- 1.1 STATISTICALLY, THE OUTBOARD SECTION IS A 92% ACCURATE INDICATION OF THE NEXT INBOARD SECTION AND A 84% ACCURATE INDICATOR OF THE THIRD INBOARD SECTION. FOR PRODUCTION, THE MOST OUTBOARD SECTION WILL BE TAKEN. ON A PERCENTAGE BASIS, ADDITIONAL SECTIONS WILL BE MEASURED TO CONFIRM THE ACCURACY OF THE ABOVE PERCENTAGES.
- 1.2 DATA NOT TAKEN INCLUDES:
1. SURFACE FINISH (OTHER THAN VISUAL FOR SEVERE PITTING)
 2. ROOT TO TIP LENGTH
 3. STRUCTURAL (OTHER THAN VISUAL DETECTABLE CRACKS AND DEFECTS)
- 1.3 (SEE FIG. #2) EACH SECTION IS DIVIDED INTO TEN EQUALLY SPACED STATIONS. THE SPACING IS DETERMINED BY DIVIDING THE CHORD LENGTH OF THE OUTBOARD I.A.S.*** INTO EQUAL PARTS, AFTER FIRST SUBTRACTING .030 FROM THE LEADING EDGE AND .020 FROM THE TRAILING EDGE.
- 1.4 FOR ANALYSIS THE UPPER (SUCTION) AND THE LOWER (PRESSURE) SURFACES ARE DEALT WITH SEPARATELY AND EACH ALIGNED IN THE FOLLOWING WAY:
- THE MEASURED VALUES OF STATIONS 1 AND 10 ARE ALIGNED TO ZERO. THE MEASURED VALUE OF STATIONS 2 THRU 9 IS ADJUSTED TO CORRESPOND. THE ADJUSTED VALUE OF STATION 6 IS THEN COMPARED TO THE I.A.S. VALUE FOR STATION 6 (THE I.A.S. IS POSITIONED SO THAT STATIONS 1 AND 10 ARE ZERO). ONE HALF THE DIFFERENCE BETWEEN THE I.A.S. VALUE AT 6 AND THE MEASURED VALUE IS THEN SUBTRACTED FROM THE ADJUSTED VALUES OF STATIONS 1 THRU 10. THESE CORRECTED VALUES ARE THEN COMPARED TO THE I.A.S. FOR ACCEPTANCE OR REJECTIONS PER 2.1.
- 1.5 CHORD LENGTH WILL BE TAKEN .10 INCHES FROM THE BLADE TIP AND AT THE FORE AND AFT CENTER LINE (OR .187 IN FROM LEADING EDGE TIP). SEE 2.6 FOR ACCEPTANCE STANDARDS.

***IDEAL AIRFOIL SECTION

REV I 3/81

COMPLETE SPECIFICATION AVAILABLE UPON REQUEST.

ROBERS-DIERKS
PRECISION REPAIRS

2017 SOUTH MEBA, SAN PEDRO, CA 90731 (213) 547-2437

FIGURE 1.

JT8D

FAN
LP
COMPRESSOR
HP
COMPRESSOR
HP
TURBINE
LP
TURBINE

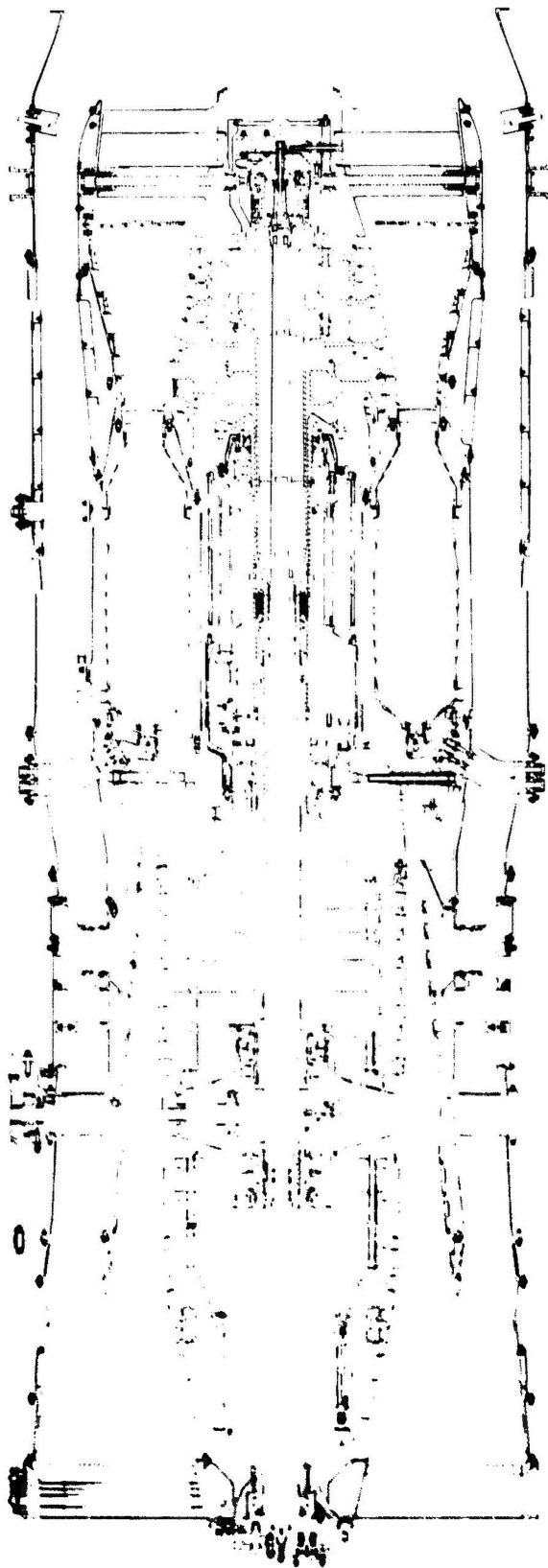

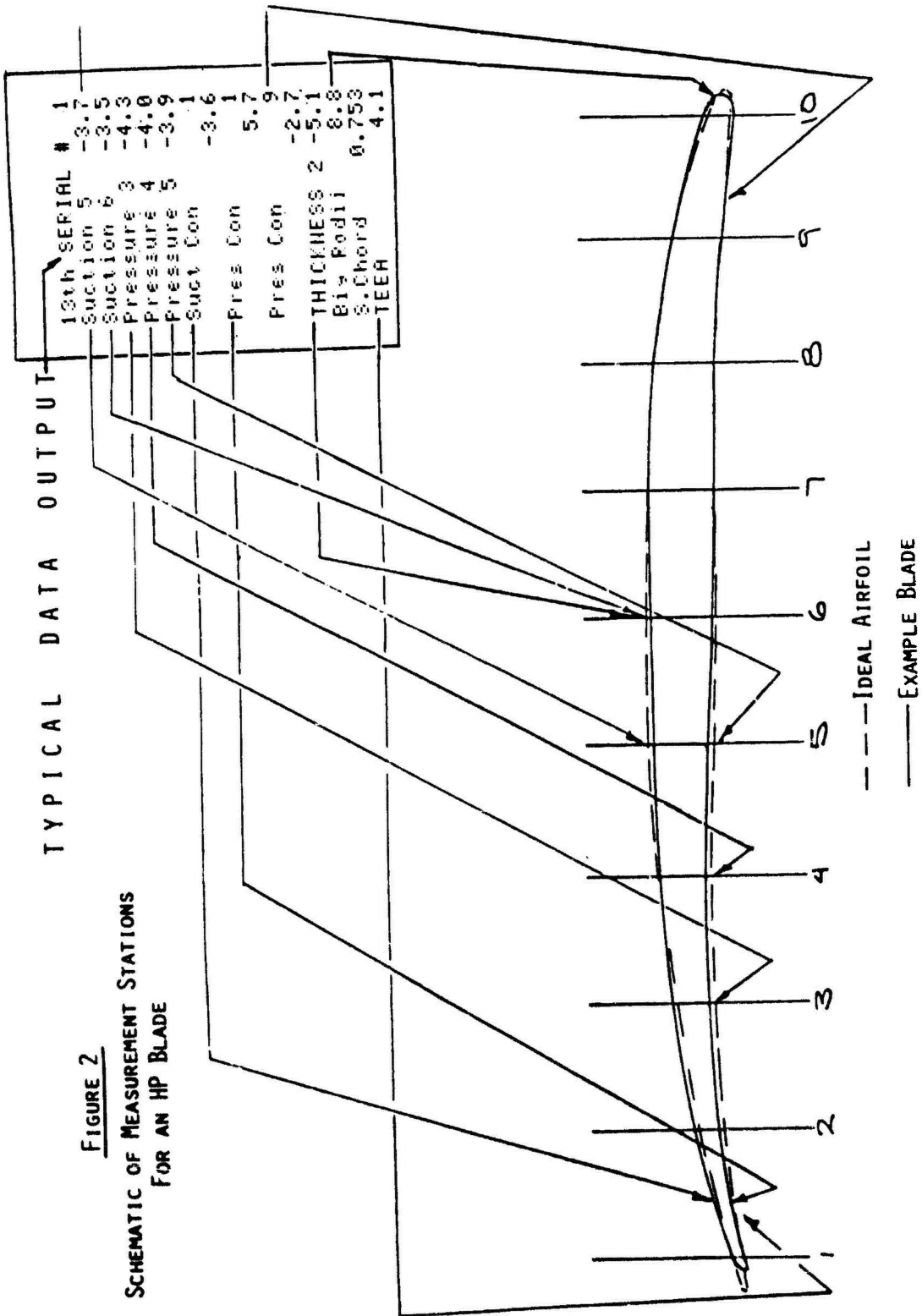

FIGURE 2
SCHEMATIC OF MEASUREMENT STATIONS
FOR AN HP BLADE

NOTE: ALL DATA IS THOUSANDTHS OF AN INCH, EXCEPT "TEEA" & "CHORD" (EXAMPLE: -3.7 IS -.0037)

FIGURE 3.

THICKNESS COMPARISON

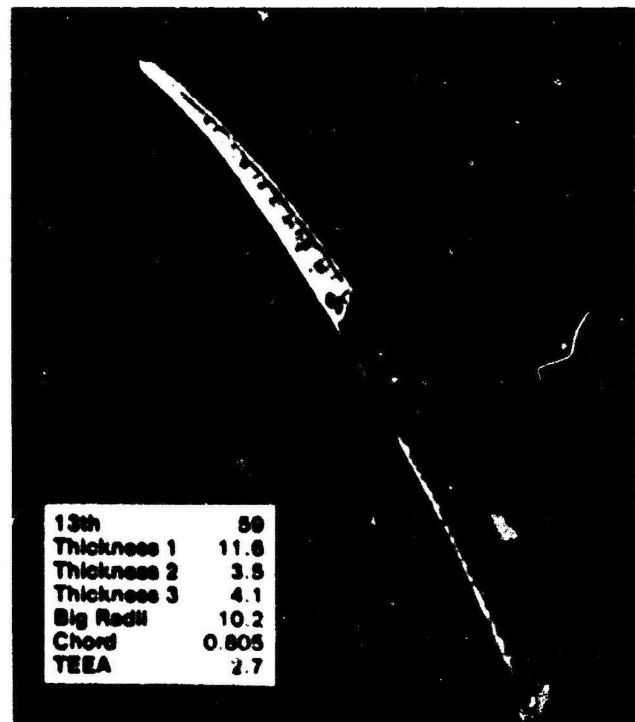
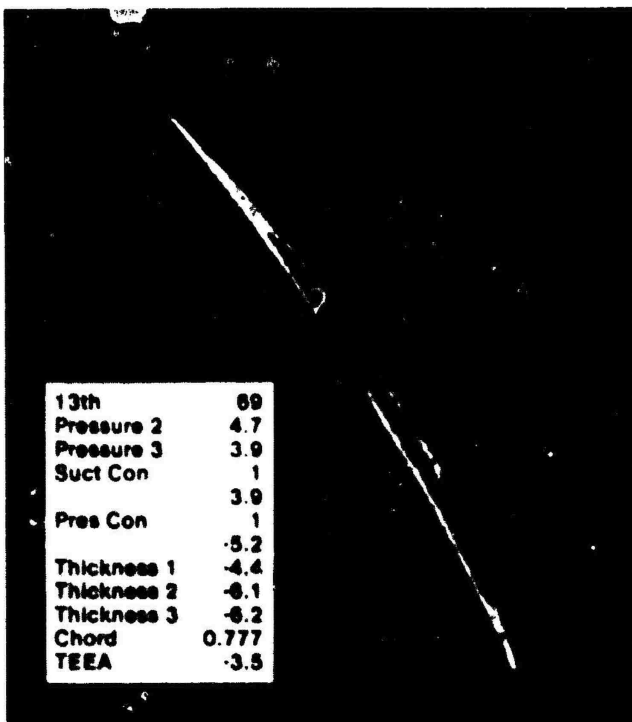
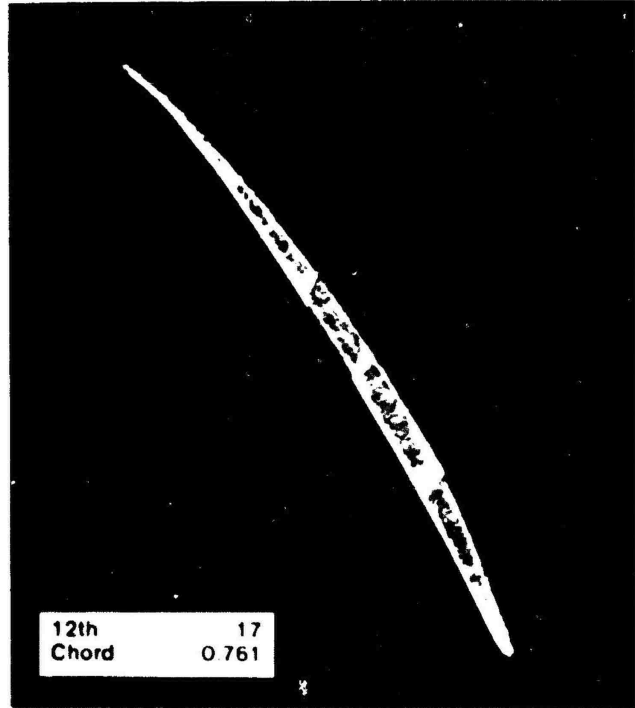
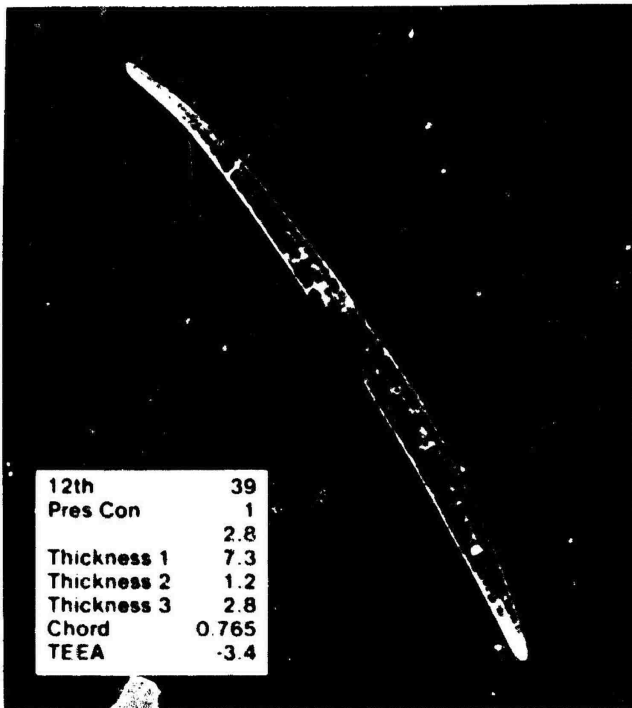

FIGURE 4.

TRAILING EDGE EXIT ANGLE COMPARISON

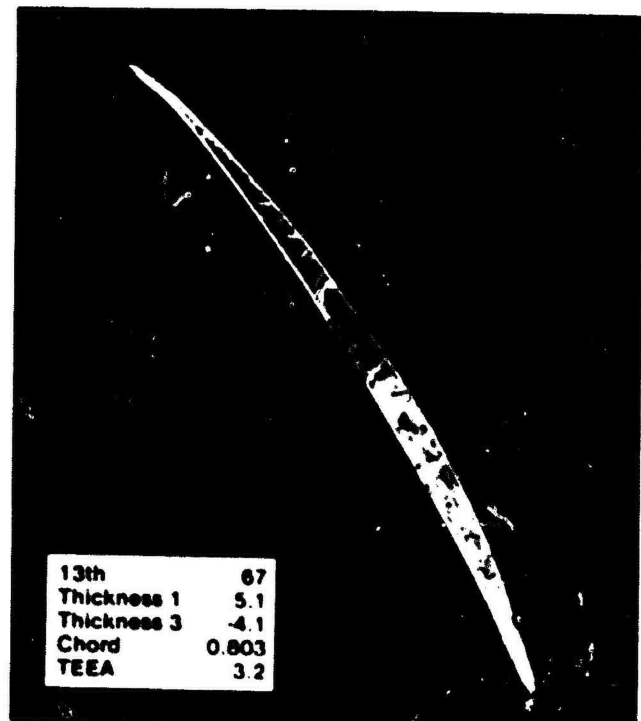
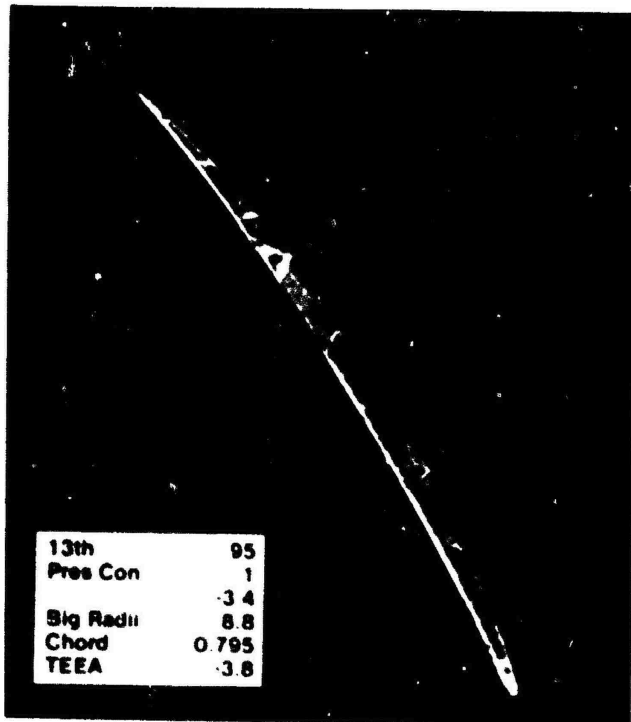
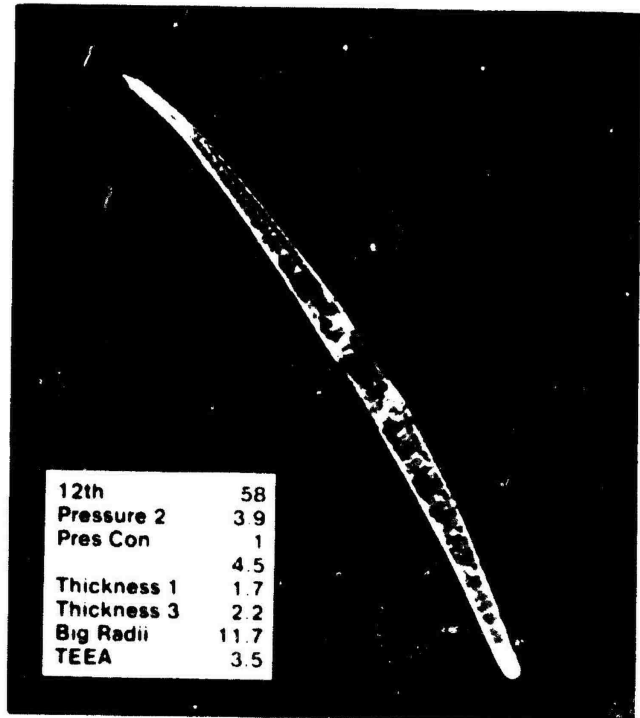
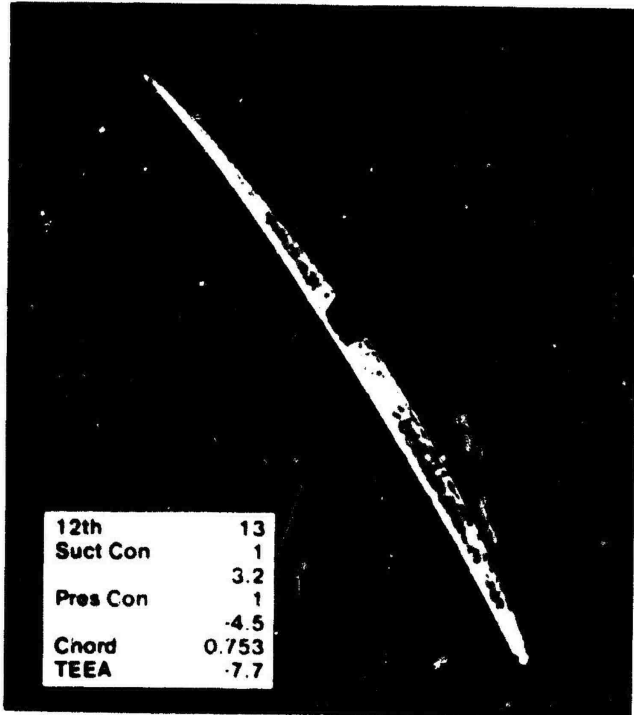

FIGURE 5.

“DOLPHIN-NOSE” SUCTION CONTINUITY 9 IRREGULARITY

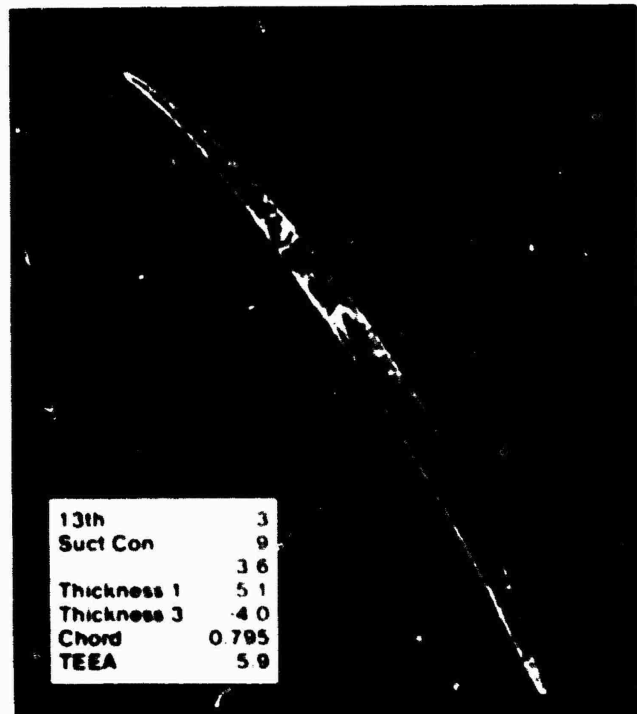
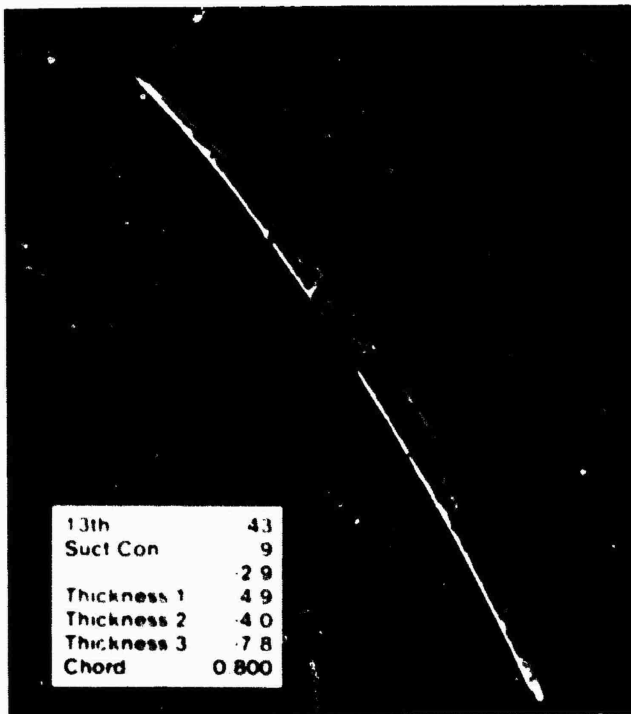
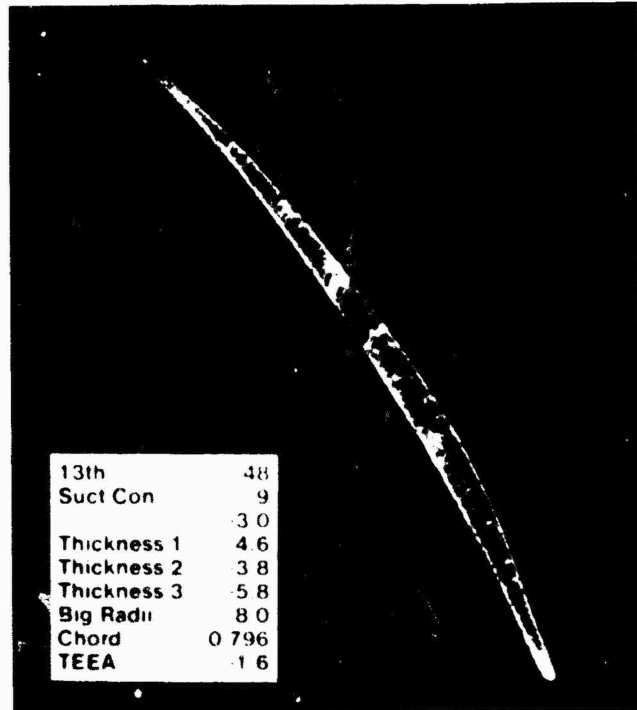
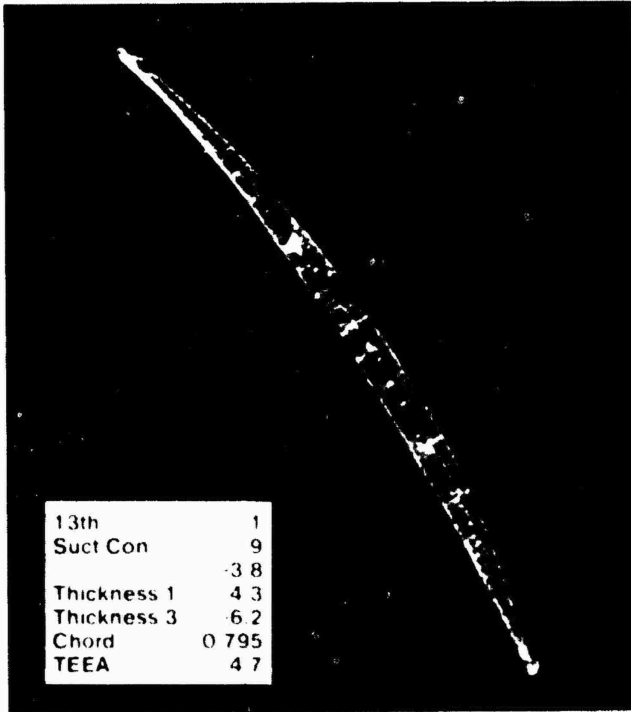

FIGURE 6.

LEADING EDGE VARIATIONS

NEW BLADE VARIATIONS

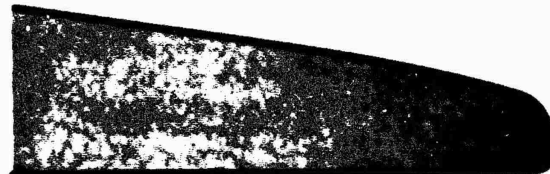
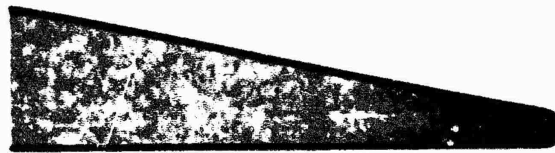
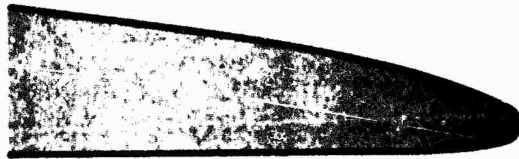
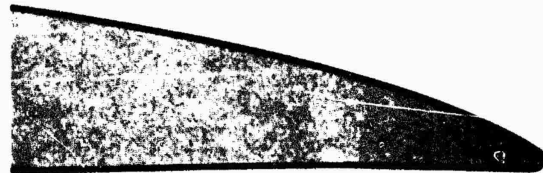

FIGURE 7.

TRAILING EDGE VARIATIONS

NEW BLADE VARIATIONS



FIGURE 8.

LEADING EDGE REWORK

RD305

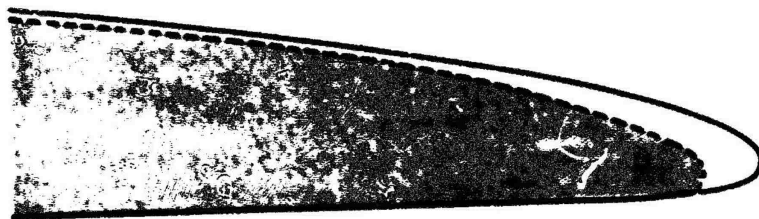
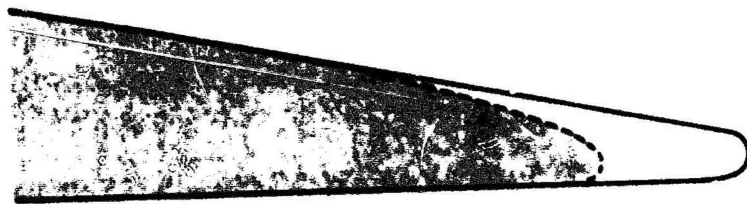
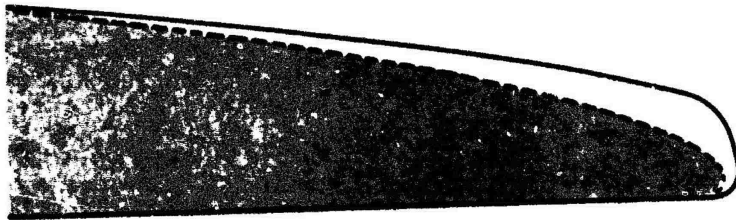
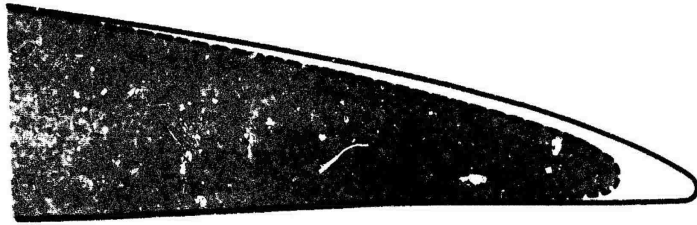

FIGURE 9.

PERFORMANCE RESTORATION

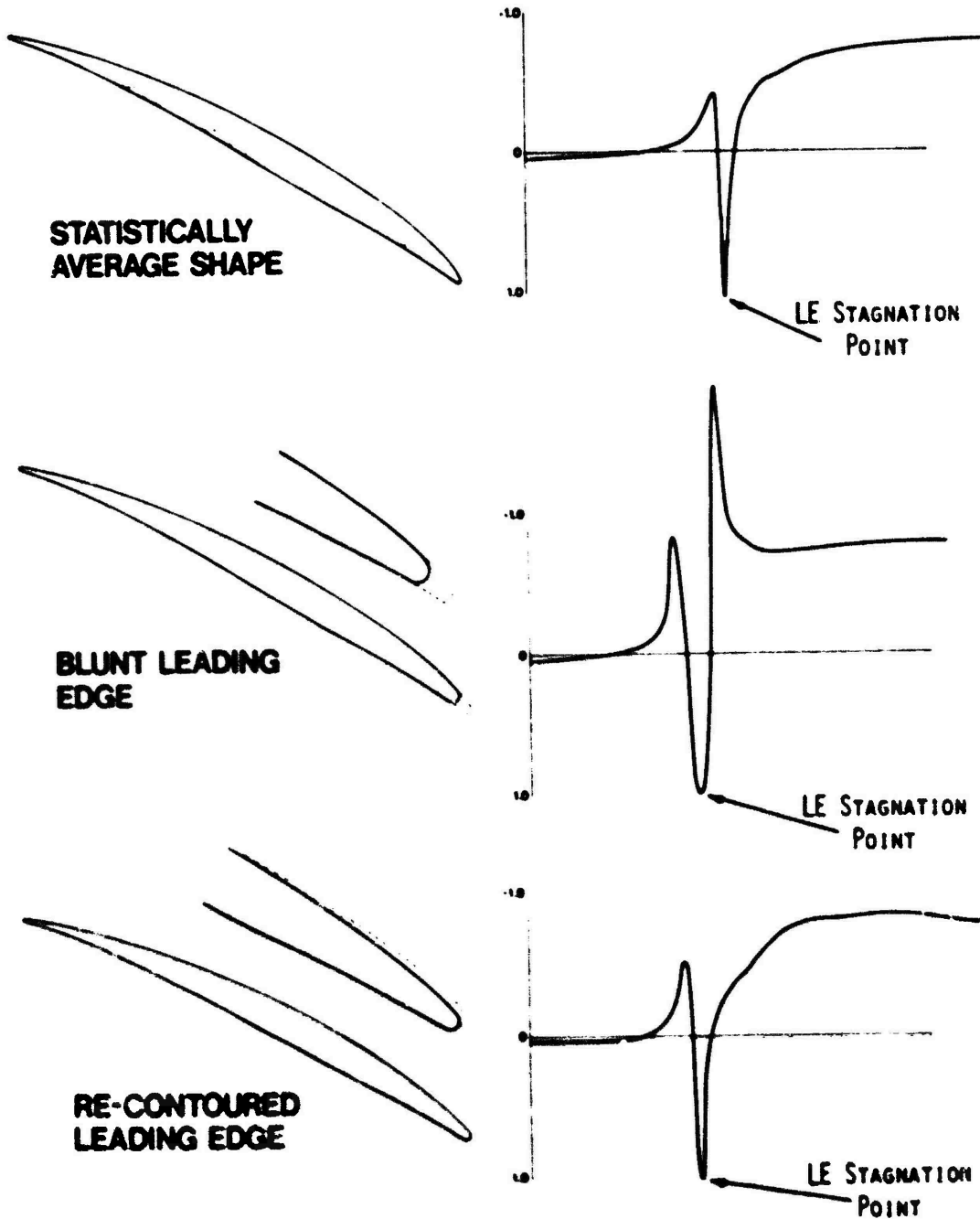

FIGURE 10.

PERFORMANCE COMPARISON
JT8D-9A

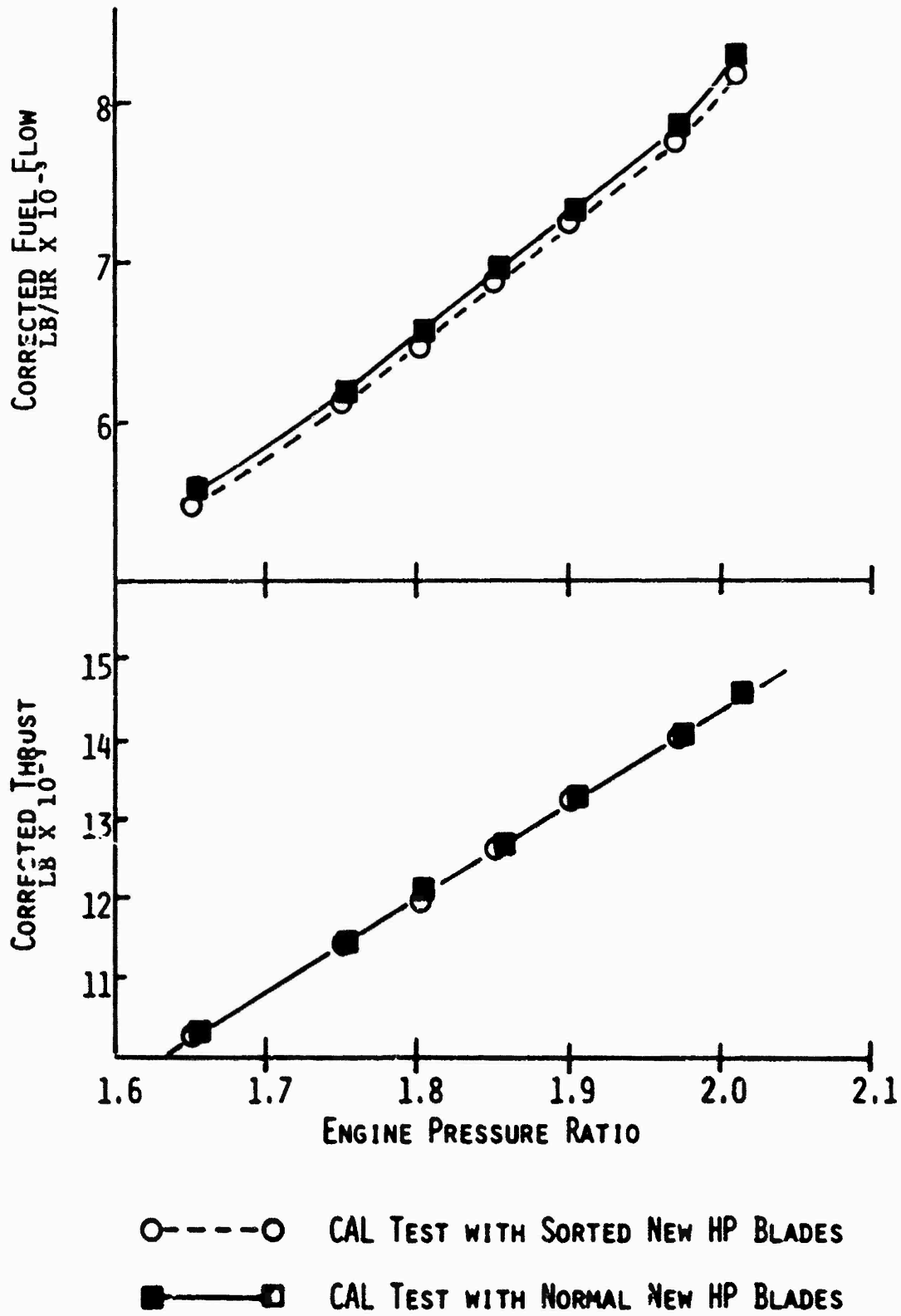
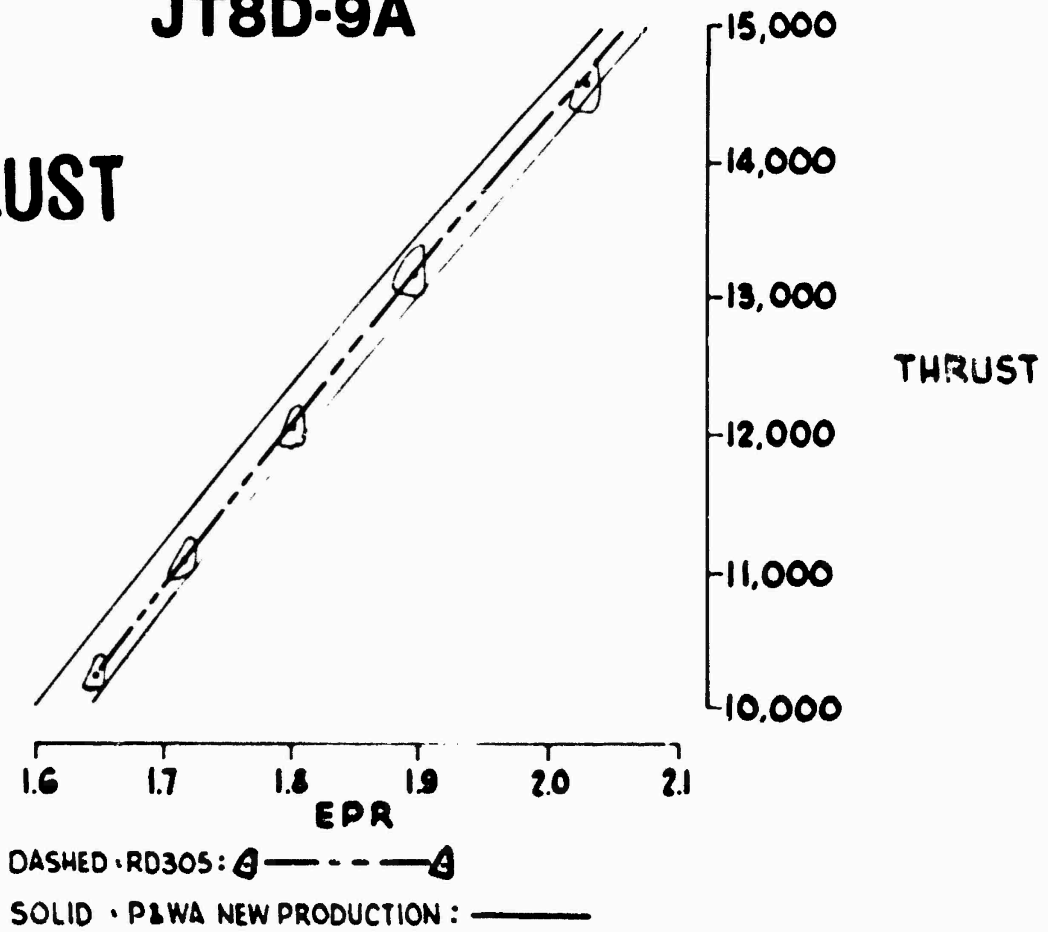

FIGURE 11.

PERFORMANCE COMPARISON JT8D-9A

THRUST



EXHAUST GAS TEMPERATURE

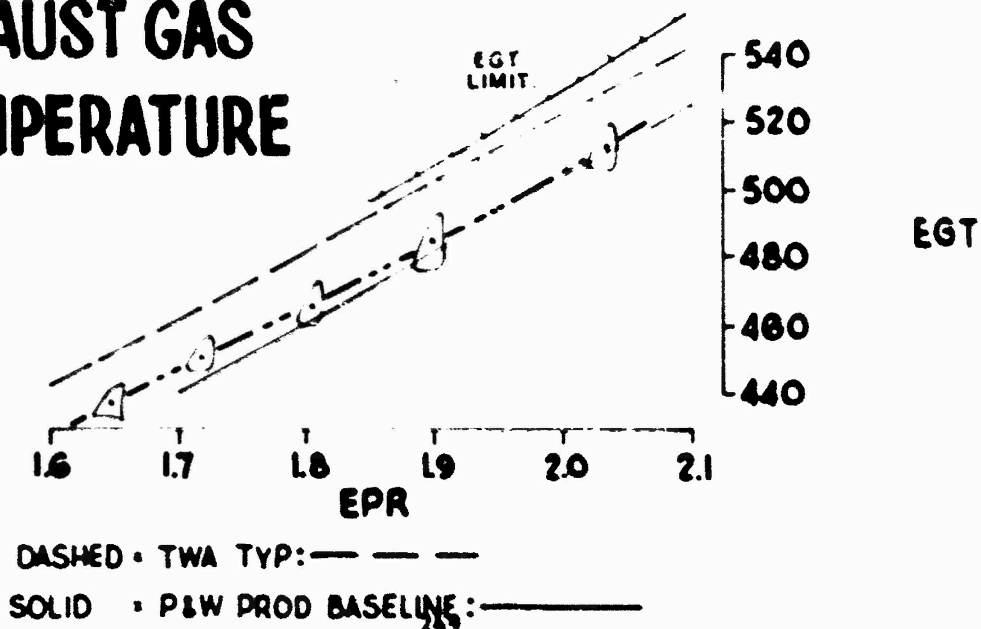
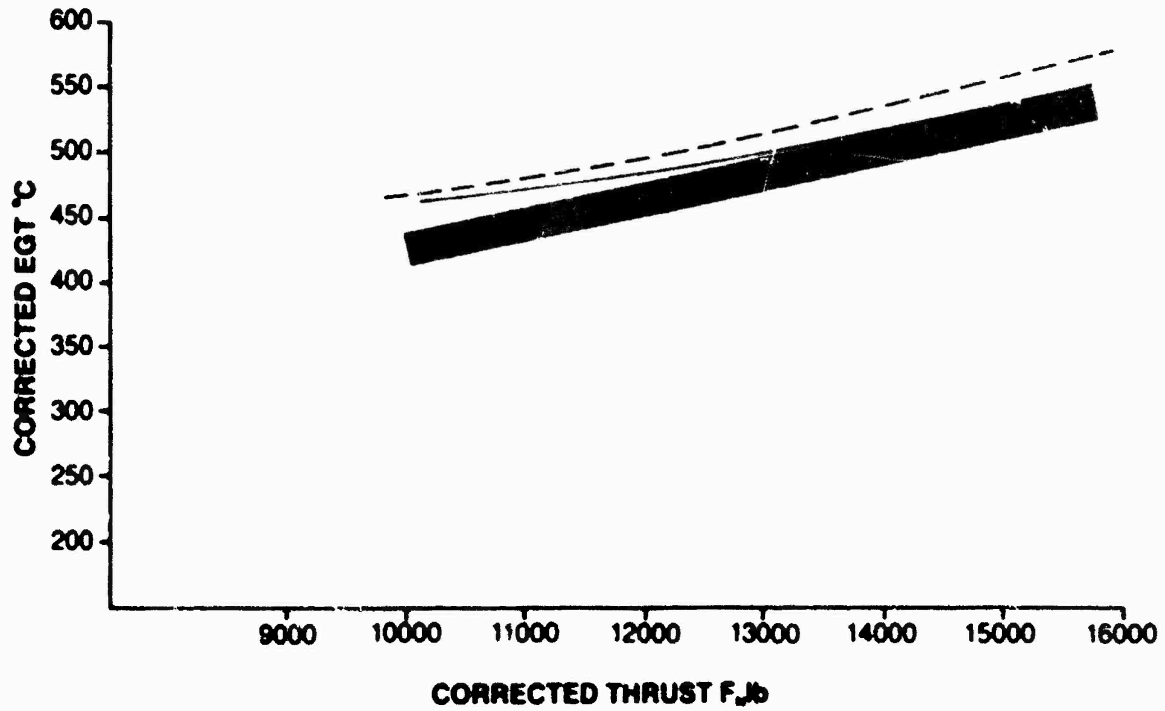

FIGURE 12.

RD305 PERFORMANCE COMPARISON—JT8D-15

EGT



TSFC

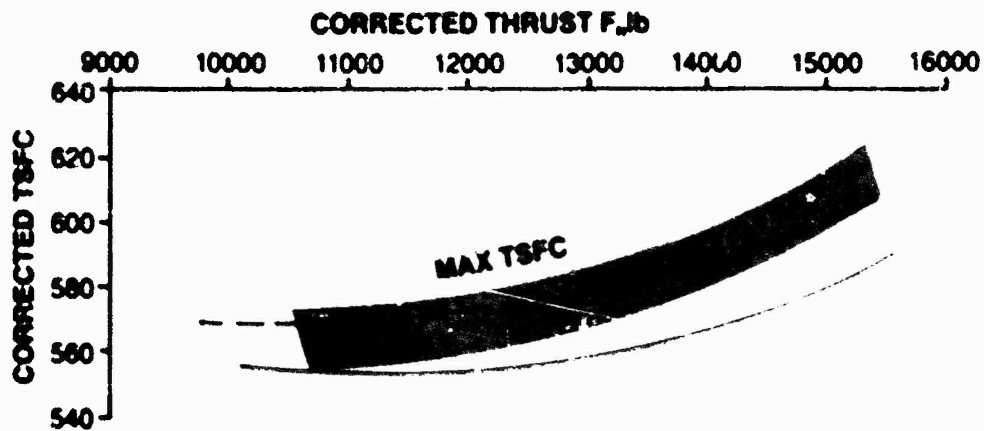

LEGEND

- WITH RD305
 - - - WITHOUT RD305
- } REPUBLIC/AIRWEST CELL TEST DATA

FIGURE 13.
REFURBISHED JT8D FIRST STAGE FAN BLADES

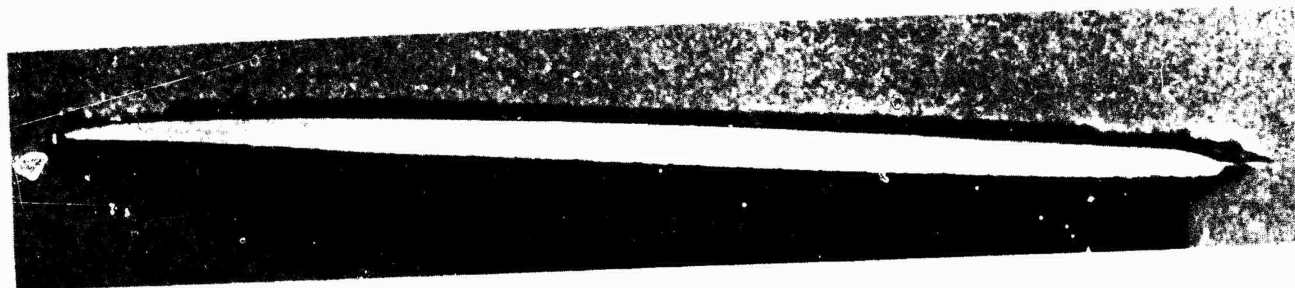
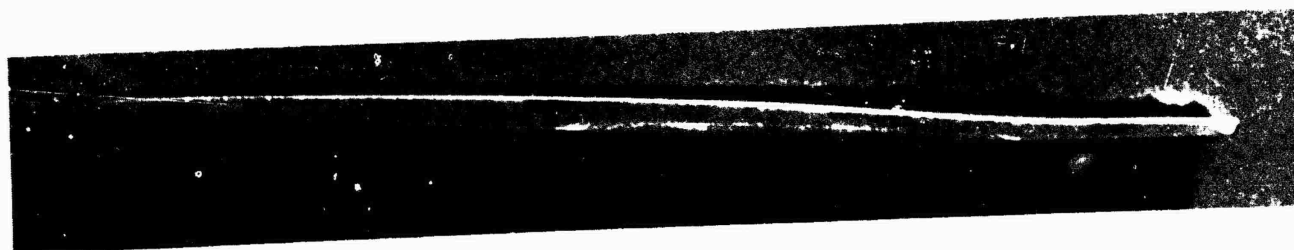
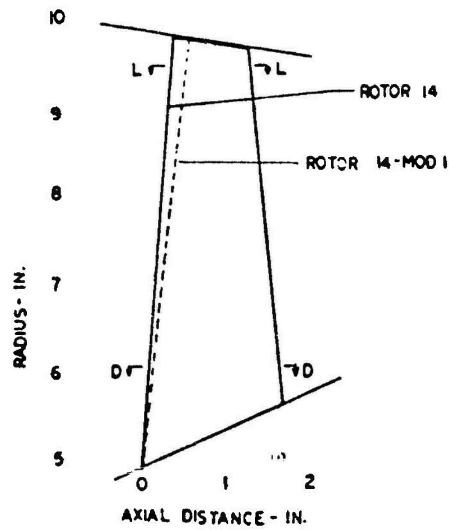
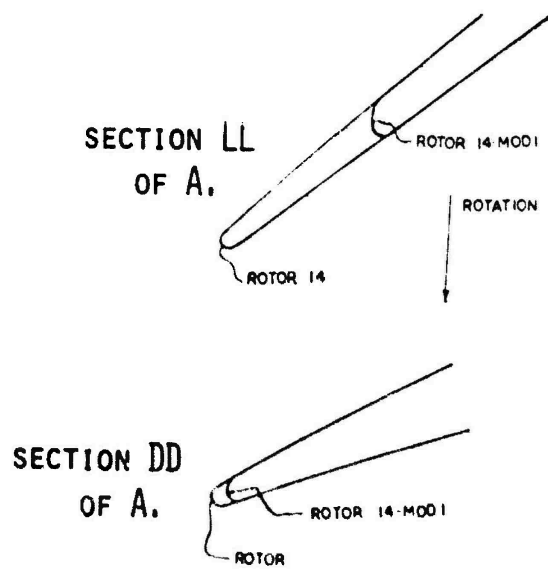

FIGURE 14.
NASA RESEARCH FAN WITH BLUNT LEADING EDGE



A. AXIAL PROJECTION OF ROTOR BLADE



B. ROTOR LEADING EDGE CONFIGURATION

FIGURE 15.
NASA FAN PERFORMANCE

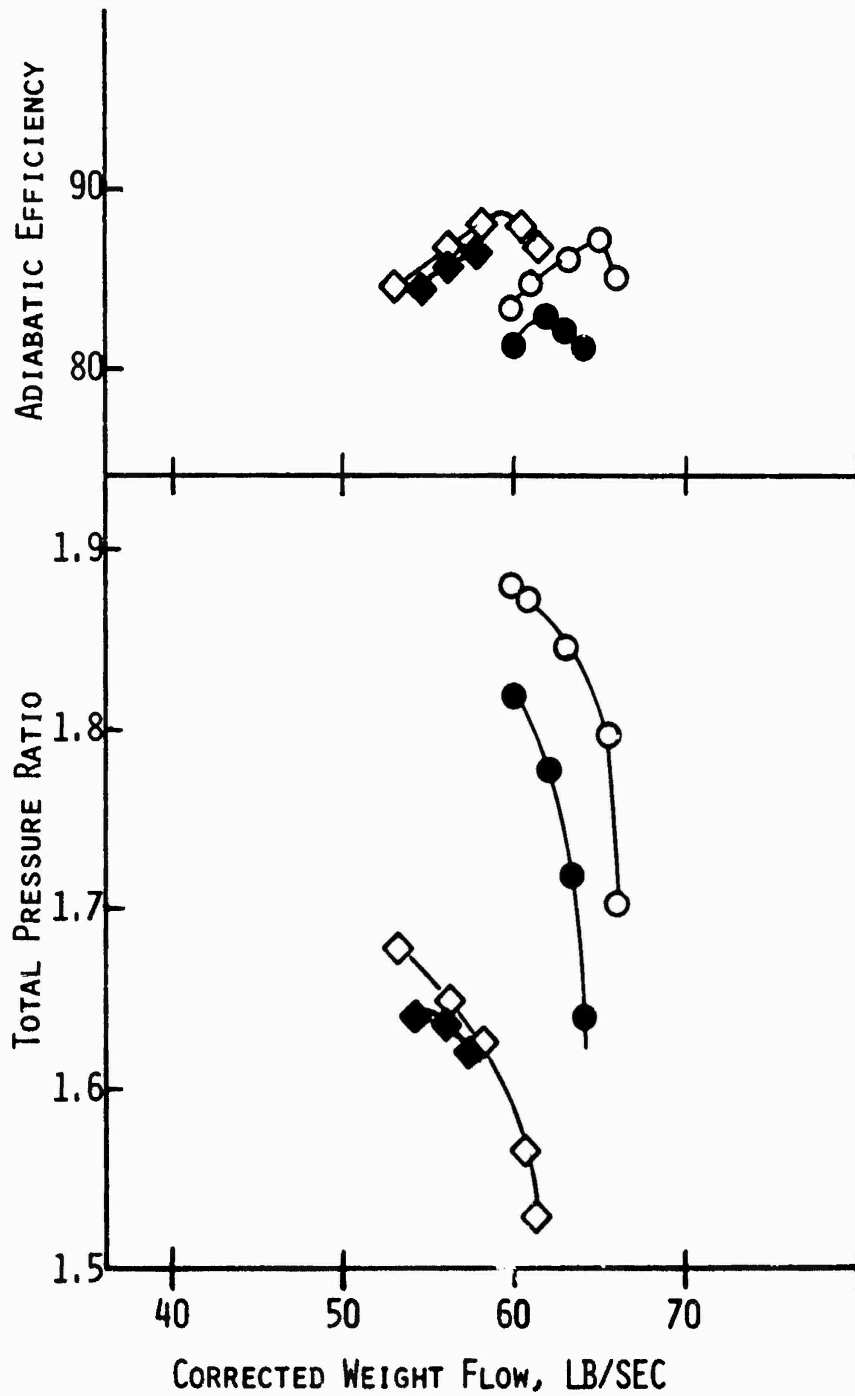

○ — ○ - 100% DESIGN SPEED
 ◇ — ◇ - 90% DESIGN SPEED
 OPEN SYMBOL - UNMODIFIED FAN
 CLOSED SYMBOL - MODIFIED FAN (BLUNT)

FIGURE 16.

FAN PROFILE SCHEMATIC

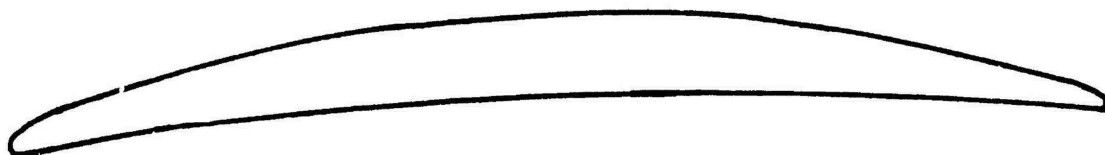

REFURBISHED FAN PROFILE WITHOUT
CHISEL CUT



REFURBISHED FAN PROFILE WITH
CHISEL CUT

FIGURE 17.

PERFORMANCE COMPARISON: JT8D

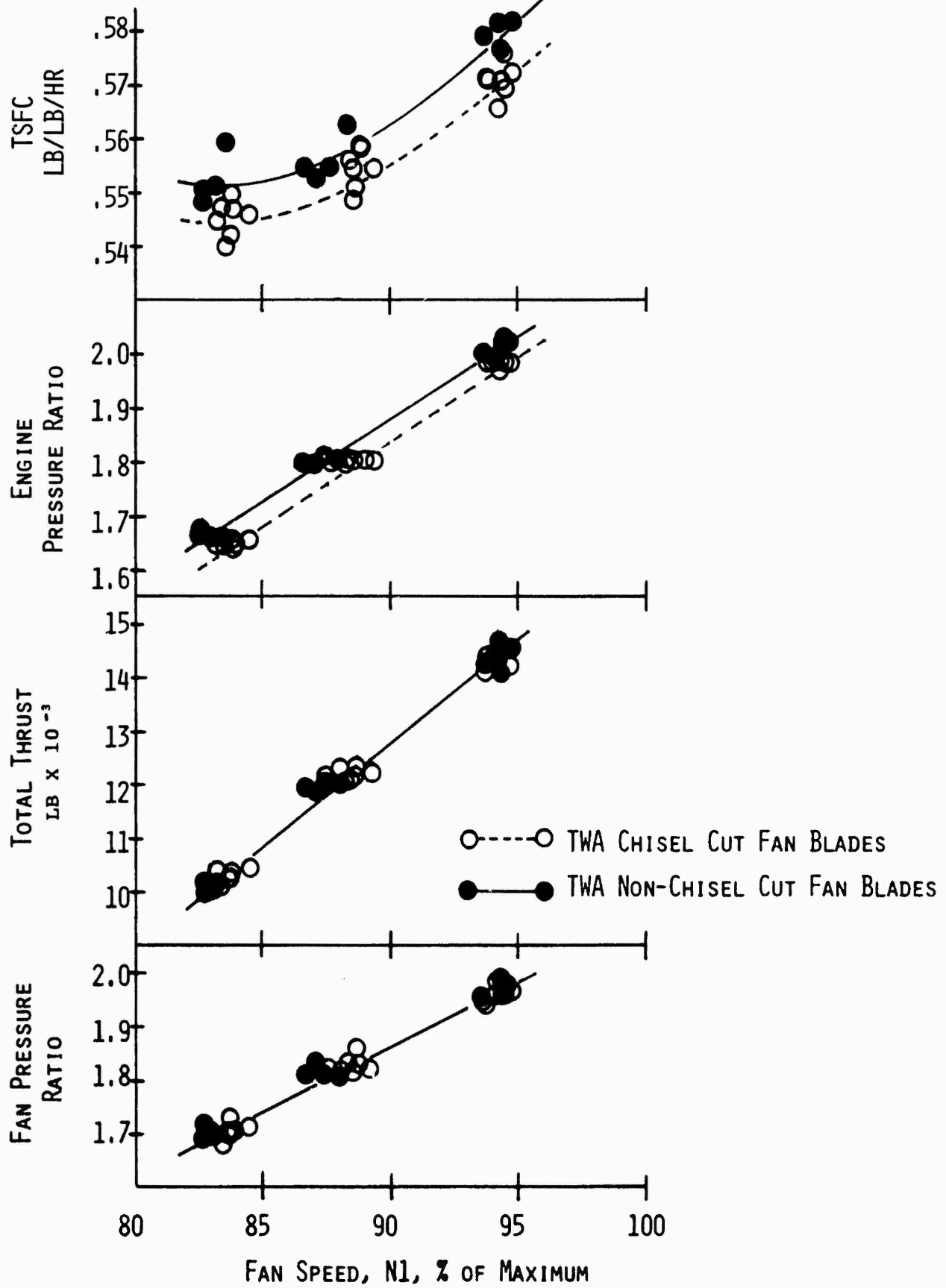
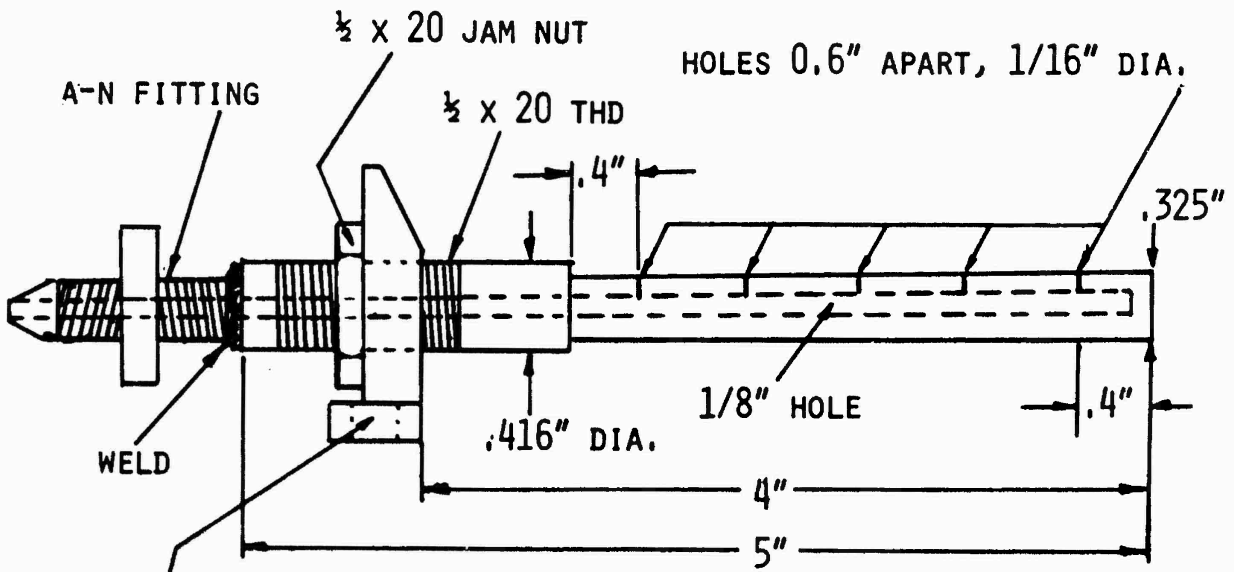

FIGURE 18.

JT8D FAN DUCT PRESSURE PROBE
MADE FROM STEEL OR ALUMINUM

S I D E V I E W



BORESCOPE
PLUG BRACKET

HOLES IN DIRECTION OF ARROW

F R O N T V I E W

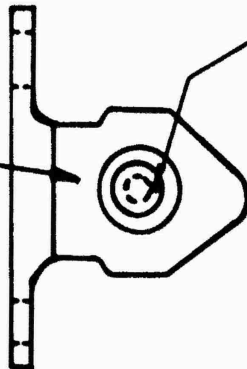

PART V

CORPORATE MANAGEMENT CONSERVATION TOOLS

A PRACTICAL ECONOMIC CRITERION
FOR FUEL CONSERVATION

D. Roger Ferguson
Eastern Airlines, Inc.

PRECEDING PAGE BLANK-NOT FILMED

A Practical Economic Criterion For Fuel Conservation

Everyone in the aviation industry is aware that fuel can be saved by the simple technique of flying aircraft at slower speeds. We are also aware that there is an economic penalty in pursuing this policy to its ultimate limit.

We all know that there is a crew cost, additional maintenance expense and a penalty of lost revenue from slowing down. The task of quantifying those costs, especially the crew costs, given the complexity of duty rigs has caused most of us to throw up our hands and set arbitrary speeds that reflect imperfect value judgments. These value judgments are correct for some situations and incorrect for others. No policy decision can possibly encompass all the variables of temperature, wind, wind gradients and payload encountered by the thousands of flights operated by each airline over the course of a year.

Most airlines have the capability in their Computer Flight Plan systems to optimize each flight for the variables of wind, wind gradient, temperature and payload, but they have not been able to resolve the value of time to use that would allow the computer to optimize each flight consistently and correctly. This paper will propose a method of determining the value of time to input into the least cost method of computer flight planning that will optimize the fuel-time trade-offs available over the planning time horizon.

The establishment of the value of time is based on a simple premise: THE VALUE OF AN AIRPLANE'S TIME TO AN AIRLINE IS THAT AIRPLANE'S EARNING POWER. The value of an aircraft minute saved is determined by what that aircraft can earn in an additional minute of revenue service. The value of a minute lost is also measured by what the aircraft could have earned had not that minute been lost.

There are those who would argue that the saving or loss of one or two minutes per flight cannot have a meaningful impact on fleet utilization. We have evaluated our schedules over the years and determined that they consistently meet our ground time standards closely. Therefore, over the long time horizon, one or two minute adjustments to flying times do get built into our utilization.

The earning value of an aircraft can be easily determined by an airline using its Profit and Loss by flight system for each aircraft type. The basic equation for this calculation is:

$$\text{Earning Value Per Minute} = \frac{(\text{Net Revenue} - \text{Aircraft DOC})}{\text{Useable Aircraft Time}}$$

Net revenue is revenue minus passenger related expenses.

(Chart I)

Chart I depicts the values per minute calculated by Eastern for each of its aircraft types. Since internal financial data is proprietary, a detailed definition of the exact expense components used, the length of the useable aircraft time specified, and the base period used to determine these values will be omitted to prevent reconstruction of proprietary data. These definitions are not important. Each company needs to interpret its data in the manner it believes in to arrive at its own earning value of aircraft time.

Once an airline determines for itself what it believes to be the correct earning value of time for each aircraft type, then it should evaluate each portion of the flight, climb, cruise and descent to select the correct speed to use to optimize the flight profile.

In the interest of time, the climb portion of flight will be omitted. The value we had used since 1974 appeared to be relatively optimal and most airlines are climbing in a similar manner. In discussing descent and cruise for short segments, the B-727 types will be discussed, although the same approach was applied to all Eastern aircraft types.

The discussion of cruise at normal cruise altitude will include B-727, DC-9 and A300 aircraft. Each of these aircraft reacts very differently to wind altitude trade-offs and some interesting conclusions emerge. The L-1011 is not discussed as we do not have autothrottles and a change in our M.84 policy is considered impractical without that system.

Low Altitude Cruise. Low altitude cruise is used on short segments of under 300 miles when a climb and descent to normal altitudes is impractical. In many areas of the country, the distance travelled at these altitudes is substantial due to system imposed limitations to keep short flights below traffic flows into and out of major terminal areas.

(Chart II)

Deriving the time-fuel trade-offs at these altitudes is easily accomplished by plotting data from the specific range curves supplied by the manufacturer. Curve A of Chart II is the total fuel cost per 100 nautical miles of level flight at a typical 20,000 foot altitude plotted versus decreasing speeds. Curve B is the time increase incurred to travel the 100 nautical mile as the speed decreases. Curve C is the Delta fuel savings for each increment of slowdown divided by the Delta time increase required. It provides a smooth curve expressed in fuel savings per minute of time lost. A fuel cost of \$.90 per gallon was assumed.

The optimum speed for low altitude cruise was obtained by matching the earning value per minute of airplane time with the fuel savings per minute. A speed of .715 Mach or 326 knots IAS was determined to be optimum for B-727-225A. The same analysis for B-727-225 aircraft yielded a .71 Mach or 324 knots IAS, while the optimum for the B-727-100 was .66 Mach or 304 knots IAS. To achieve a common practice for all B-727s, since the pilots fly them interchangeably, a speed of 320 knots IAS was selected and implemented.

Descent. The decent portion of flight was one of the most difficult to evaluate, since there are two regions of descent, the Mach number portion above crossover, and the constant IAS portion. This makes it impossible to develop a continuous curve, as was derived for the low altitude cruise analysis. Instead, we gathered data from the manufacturer on as many descent profiles as possible, ranked them in order from least time to longest time, and compared each increment of slowing down (Chart III). Boeing supplied data for the five descent profiles that appear on the chart. Curve A is the total fuel per trip savings referenced to a baseline of the M.84/350/250 descent profile we were using at the time the analysis was done. Curve B is the total time increase relative to the M.84/350/250 descent. Curve C is the plot of the incremental fuel savings divided by the time increase. In this case the curve is not continuous, but rather lines joining discreet points.

(Chart III)

As is readily apparent from the charts, the descent Eastern was using was much too fast. The first increment of slowdown, from M.84/350/250 to M.80/320/250 saves about \$11 in fuel with a time increase of .4 minutes. This works out to a fuel saving of \$27.5 per minute, while the aircraft is only earning \$11 per minute from increased flying.

The next increment of slowdown to M.80/300/250 generates nearly the same fuel savings. There is a fuel savings of \$10.1 measured against a time loss of .4 minutes or a rate of \$25.5 per minute, again well above the earning power of the airplane.

The third increment of slowdown to M.80/280/250 is a different story. The fuel savings came out at \$8.2 versus a time loss of .8 minutes, or \$10.3 per minute. This is less than earning value of the airplane, although it is so close that I would certainly never argue with a decision to select this speed, nor would I disagree with those airlines using this speed. Eastern chose to stop at 300 knots IAS below crossover mainly to limit the increase in our block times, at least until we have a chance to settle in at the times generated by the 300 IAS descent. When we average all aircraft types, we are achieving 68 percent of the fuel savings with only 45 percent of the time increase by using the 300 IAS descent instead of the 280 IAS descent. As we adjust to the increased times, and as fuel prices continue to rise, I am sure that we will eventually adopt the 280 knot profile.

As the chart shows, further slowdown to 250 IAS yields very little additional fuel savings, yet results in a major increase in time. Descent profiles using speeds below 280 are not likely to become economical in the foreseeable future.

Cruise At Normal Altitudes. To the best of my knowledge, all airlines have abandoned the use of the least cost model for computer flight planning. Instead, they have set a fuel conservation cruise policy, normally either M.80 or long-range cruise (for the B-727), and then let the computer select the least fuel flight plan generated by this policy. The difficulty with this approach is that it works well for the average airplane at the average weight, at the normal temperature, in the no wind case, but not everywhere else.

(Chart IV)

Chart IV is a curve showing the fuel cost per minute of time saved as speed increases for average aircraft weight and temperature at no wind. It shows each of the B-727 types and how the implicit aircraft value of Eastern's policy of M.80 cruise compares with the earning value of the airplanes. It is easily seen that M.80 is a very good choice. It is a little slow for the B-727-225A (-15 powered), just right for the B-727-225 (-7 powered) and too fast for the B-727-100. All things considered, M.80 is the best choice for speed if it is going to be done by a policy decision. The difficulty with this approach is that once you restrict a computer flight planning system to a set speed, it will almost always select the same altitude, where the flight will encounter whatever wind and temperature conditions exist at that altitude.

(Chart V)

Chart V is a schematic representation of the region where the choice of M.80 is the correct solution, even under a least cost approach to computer flight planning, at least using the aircraft time value selected at Eastern. In my experience, about 80 percent of the time we receive identical flight plans from this method as from the current policy of specifying least fuel at M.80.

It is the 20 percent of exceptions that provide the insight into the advantages of determining the value of the aircraft explicitly and making it part of a least cost computer flight plan system, rather than implicitly in setting a fixed speed policy.

There is one group of examples that are represented by the area below the circle. These are heavily loaded airplanes, in the summer months, typically JT8D-7 powered B-727 stretches that can only get to 27,000 to 29,000 feet. A policy speed of M.80 at these altitudes is a gross waste of fuel. A Mach number choice around M.76 will give a comparable true air speed to that which would have been generated by M.80 at normal altitudes and save many hundreds of pounds of fuel.

Another group of examples occurs at the top of the circle. These are typically the B-727-225A aircraft with the JT8D-15 or 17 engines. With a lightly loaded aircraft, the impact of selecting 37,000 feet over 33,000 feet is often two or three minutes of time lost to save only five or ten pounds of fuel. In these cases it is cost effective to save the time to use in some other case where a much higher fuel savings can be achieved.

The right and left hand extremes of the circle involve headwind and tailwind versus speed examples. The basic principle of speed-up into a headwind to reduce the air miles travelled, while slowing to long range cruise to allow maximum benefit of a tailwind is simple and cost effective with the B-727. The use of this technique is more useful with the DC-9, so the major coverage will occur in the discussion of that airplane.

With the B-727 types, there is an additional application of the least cost model, that we feel saves several million dollars per year in fuel as well as time. The B-727 is an airplane that at M.80 will almost always go to 35,000 or 37,000 feet depending on direction of flight. At M.80, the aircraft will almost always climb through 31,000 to reach 35,000, even if the headwind is eight-ten knots stronger at that altitude. In many cases of five to ten knots wind difference between 31 and 35, the use of long range cruise at 31,000 is superior to M.80 at 35,000, in both fuel and time.

(Chart VI)

Chart VI shows the time versus fuel consumption trade-offs for the DC-9 types operated by Eastern. It is clear that the policy speed that we have selected, M.75 (which is the industry standard), is significantly slower than the earning power of DC-9 aircraft. What is also clear from the chart is that the curve of fuel consumption increase versus time decrease is relatively flat. As Mach number increases from M.73 to M.77, the incremental cost of saving time does not raise dramatically. This observation introduces two major issues for airline management's trying to make intelligent economic decisions.

The first, and most fundamental, is that the DC-9 types, at least the series 30 and especially the series 50, are inherently a fuel efficient aircraft. The use of slower speeds for these aircraft in the name of fuel conservation, will ultimately lower the utilization of these very fuel efficient aircraft, thereby leading to increased flying for fuel inefficient aircraft like the B-727-100. This approach leads only to false economy, for the total fleet deployment is not optimized for maximum fuel economy. I plan to return to this point at the end of the presentation with a comparison of the relative fuel efficiency of all the aircraft types we fly.

The second major point associated with the DC-9 curves of Chart VI is the very flatness of these curves over a relatively wide range of speed. If the fuel cost of time is relatively insensitive to speed in the no wind situation, then the use of varying speed to adjust to wind conditions can be a major tool in conserving fuel.

(Chart VII)

Chart VII plots the DC-9-30 cost of saving time by .01 Mach number increments versus wind components. As is readily apparent from this chart, the wind component has a dramatic impact on the fuel cost of saving time with this aircraft. If there is any aircraft where the use of least cost computer flight planning can generate a large pay back, it is with this aircraft. The relatively linear fuel increase for each increment of speed makes it extremely economic to fly faster into the wind. With a strong tailwind, slowing and allowing the wind to do more of the work for you is also cost effective.

Table I

Table I shows a simple example of the time and fuel for a DC-9-30 in a simple example of a 100 knot wind upon a round trip that would require one hour at cruise altitude in the no wind case. The prevailing procedure of most airlines is to fly both directions at M.75. If least cost flight planning is used and M.77 is used into the wind and M.73 is used with the wind, the round trip will use 20 pounds less fuel relative to the normal procedure.

Equally important to the airline is the effect on the time to complete the round trip. In the no wind case, the time for the round trip is two hours. With the 100 knot wind affecting these flights, the round trip time would increase 6.7 minutes if flown both directions at M.75. If the round trip is flown M.77/M.73, the time increase is limited to 5.1 minutes. Airline schedule integrity is always poor in the peak winter wind months due to the increase in round trip times required to complete the schedule pattern. The period of peak airborne time to complete a fixed pattern of flights also coincides with the poorest weather months, usually producing poor on-time records by all airlines. A fuel efficient way to shrink this net over-fly pays off in operational improvement as well as cost savings.

(Chart VIII)

Chart VIII is a schematic representation of those situations when the current policy of M.75 yields the optimum result. Because of the sensitivity to wind, any Mach number covers only a small portion of realistic wind conditions. The DC-9 has a certified service ceiling limit of 35,000 feet and is able to reach that ceiling at almost any weight. This means that examples of DC-9's flying above most economic altitude or not being able to get to an altitude where M.75 or faster is the most economical are extremely rare. I have never found one.

(Chart IX)

Chart IX shows the time versus fuel trade-offs for the A300. The contrast between this airplane and the DC-9 we have just discussed is dramatic. The A300 is an airplane that "hits a brick wall" when it goes above M.79 with fuel consumption rising all out of proportion to the value of time saved. The speed for maximum range cruise is only .02 Mach below this point at M.77.

Schematically (Chart X) the region of optimum efficiency encompasses a wide range of wind conditions within the same speed selection, but it is extremely altitude sensitive versus weight. The optimum altitude for this airplane will vary by 2000 feet for every 20,000 pounds of weight. This airplane is also distinctive in that it is physically capable of flying 4,000 feet above its most economical altitude.

Most aircraft are capable of searching for favorable wind versus altitude trade-offs only by flying below the most economic altitude, but the A300 has the advantage of being able to pick a favorable wind situation on either side of its maximum still air range altitude. This makes an effective computer flight plan system that considers a range of speeds and altitudes even more important with this aircraft.

The A300 may be of academic interest to this group, as only Eastern flies it, but I have every reason to believe that other advanced twin-engine aircraft like Boeing's 757 and 767 will behave in a similar manner to the Airbus. If this is true, a lot of airlines are going to have a major learning process to go through about aircraft behavior.

That completes the discussion of the application of the earning value to the individual regimes of flight. Let me now attempt to place the use of this technique in perspective.

(Chart XI)

Chart XI is a comparison of the explicit value of time that represents the earning value of the airplane versus the incremental cost of fuel consumption implicit in the Mach cruise policies chosen by Eastern's management. These speeds of M.80 for the B-727 and A300 and M.75 for the DC-9 are representative of the industry norms for these aircraft types.

Inspection of this chart shows that use of the explicit value of time in a least cost formulation of a computer flight plan would slow the A300 and B-727-100, speed-up the DC-9 types, and leave the B-727-200 at the same speed. The A300 stands out in that we were wrong in selecting M.80 as the speed for this aircraft in the first place.

(Chart XII)

Chart XII is a comparison of the earning capability of each aircraft per unit of fuel consumed. Ignoring the A300 whose slowing was due to setting an incorrect policy at introduction, the speed-up of the DC-9s is eminently logical. A speed-up of the two aircraft with the greatest fuel efficiency allows more utilization of the aircraft with the greatest inherent efficiency. Similarly, the net slowdown of the B-727-100 is eminently logical as there is very little incentive to generate utilization improvements from inefficient airplanes.

In summation, the use of the earning value of the airplanes as an explicit cost of time provides the opportunity for further fuel savings. It provides a consistent yardstick for achieving consistency in all regimes of flight, between different aircraft types, and across a wide range of wind, temperature and weight conditions.

CHART I

FUEL SAVINGS PROGRAM
AIRCRAFT OPPORTUNITY COST

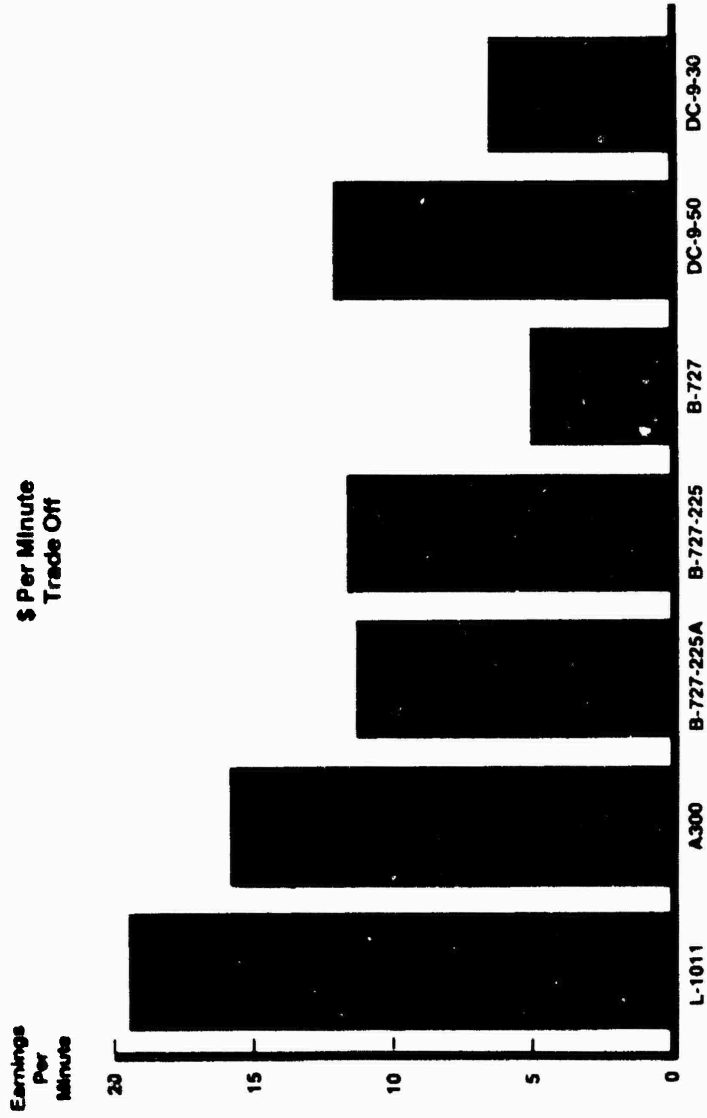
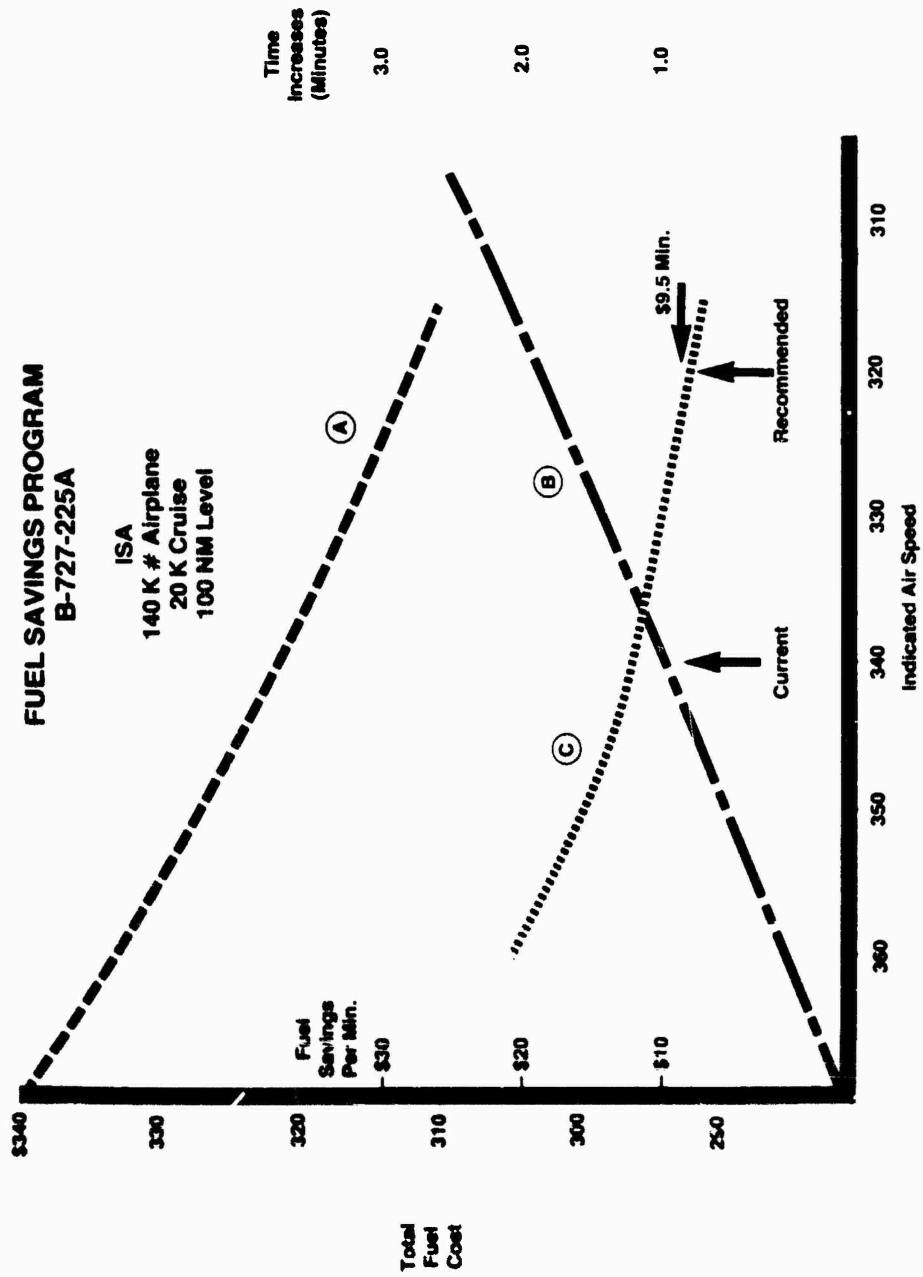

CHART II
**FUEL SAVINGS PROGRAM
 B-727-225A**

ISA
 140 K # Airplane
 20 K Cruise
 100 NM Level



FUEL SAVINGS PROGRAM

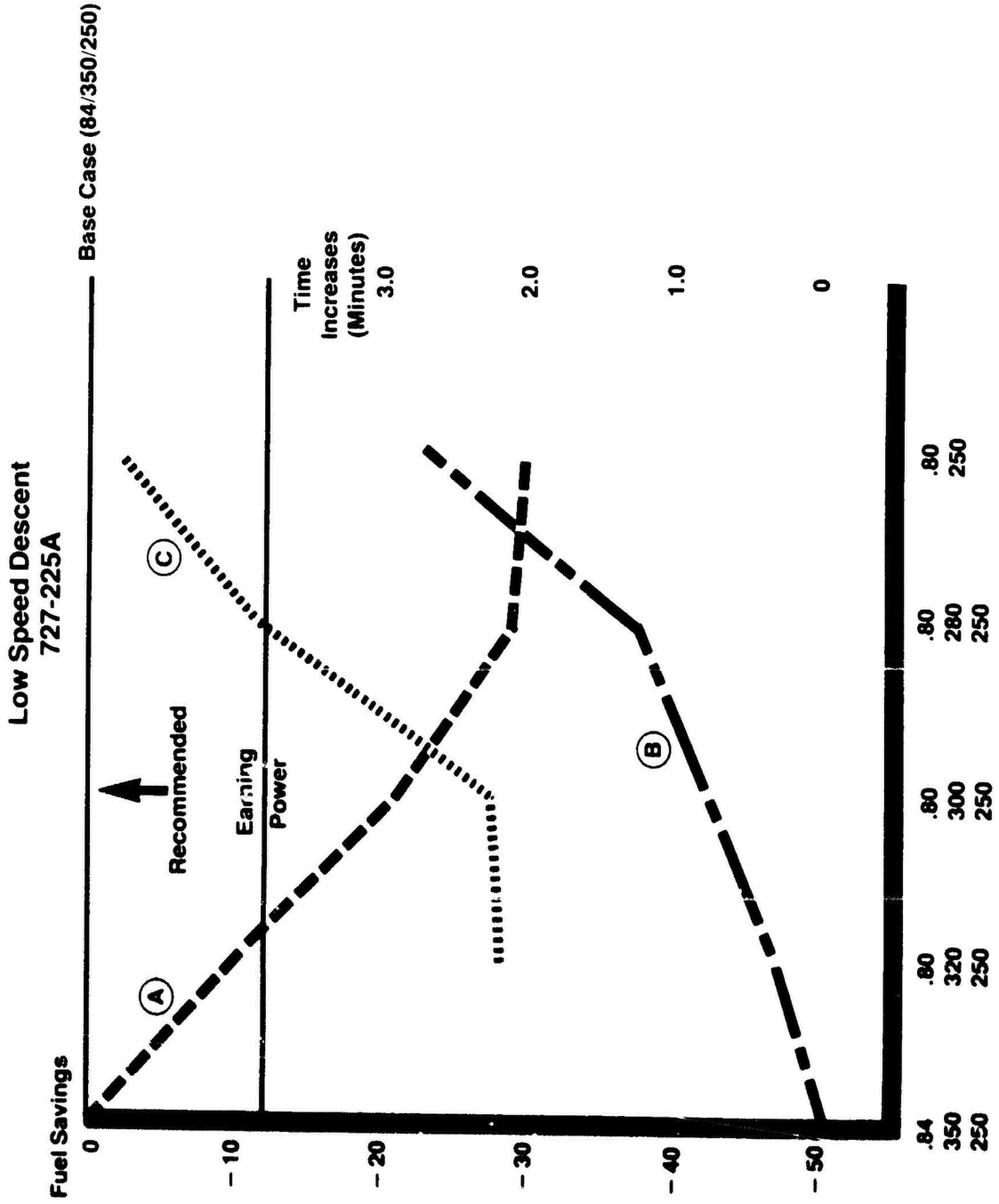

CHART IV

CRUISE POLICY

Derivation of Implicit Aircraft Values

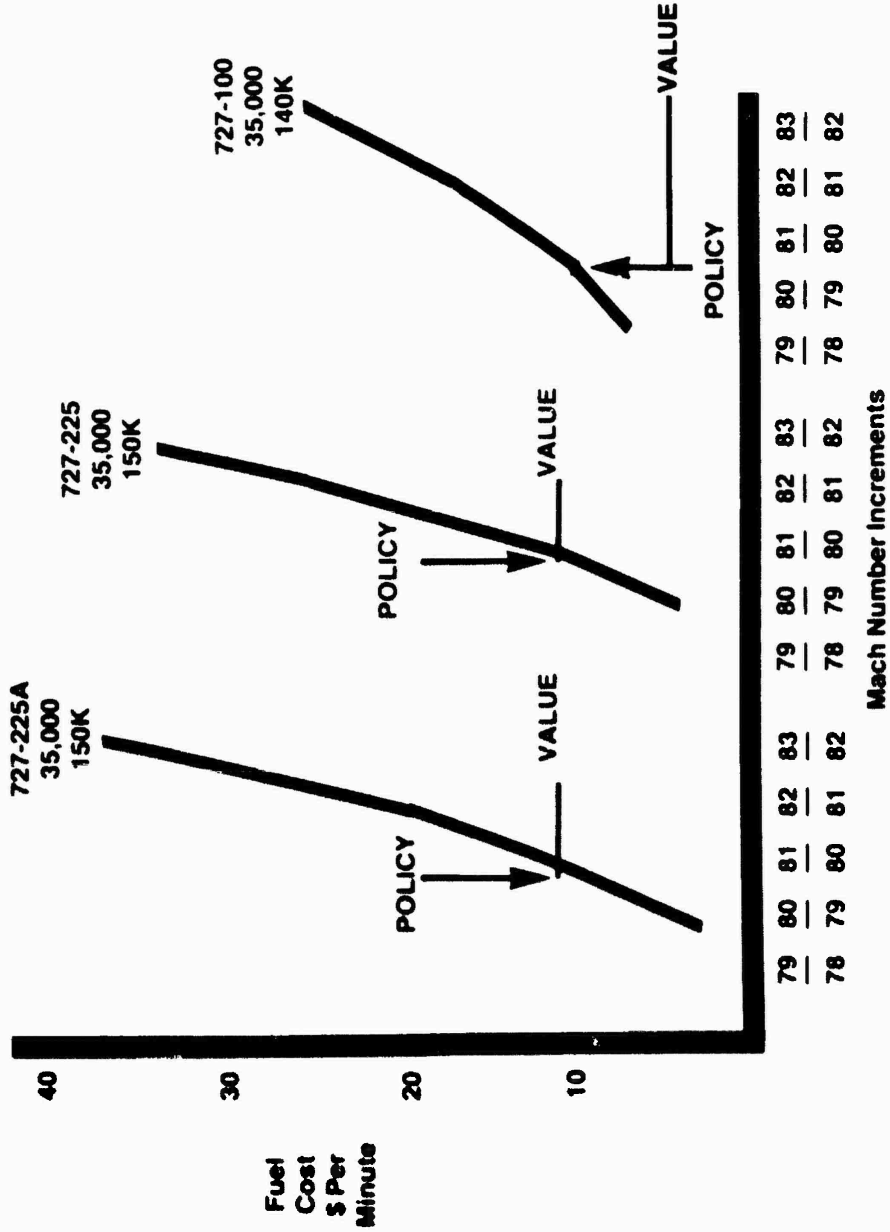
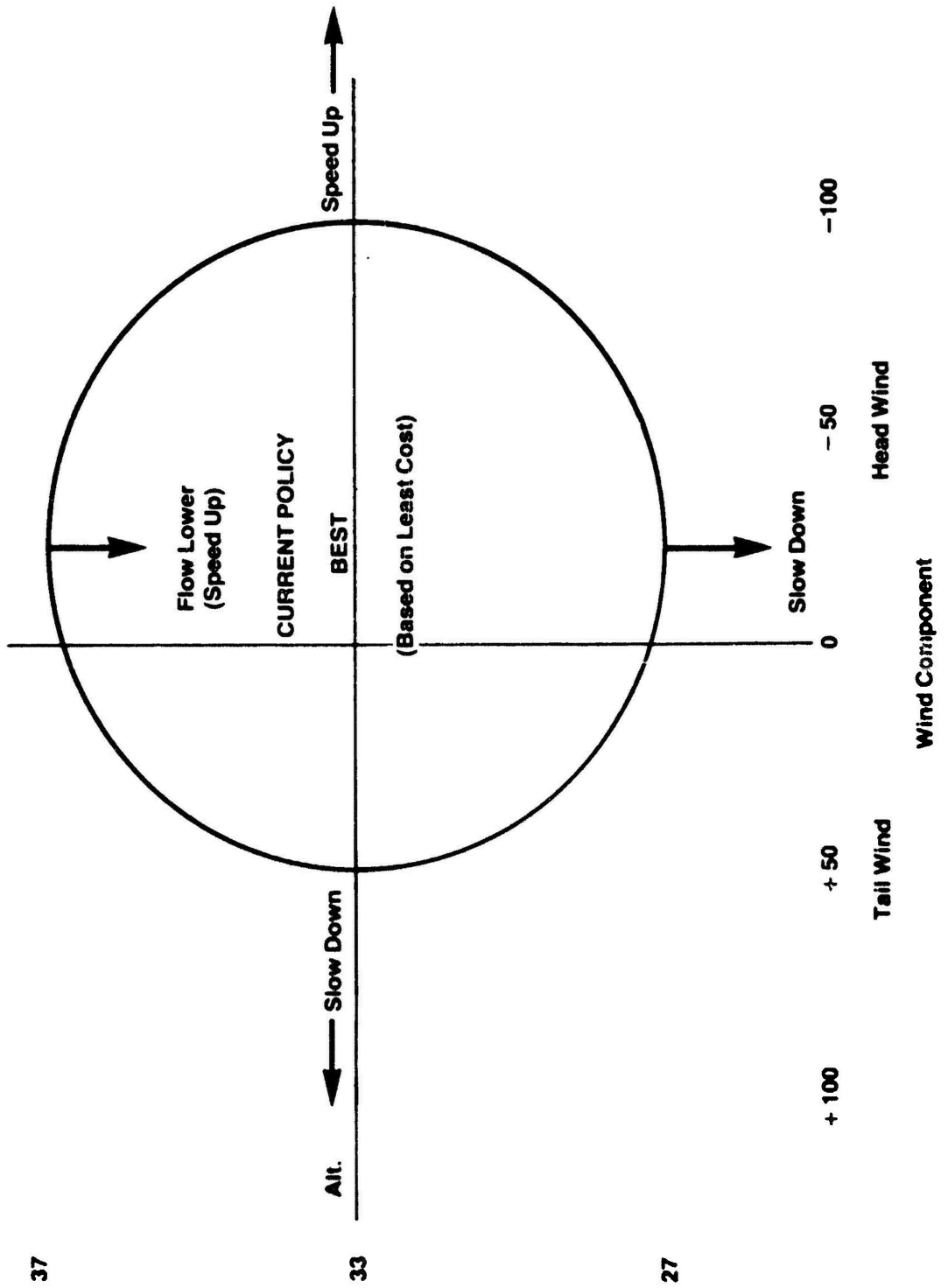

CHART V

B-727



CRUISE POLICY

Derivation of Implicit Aircraft Values

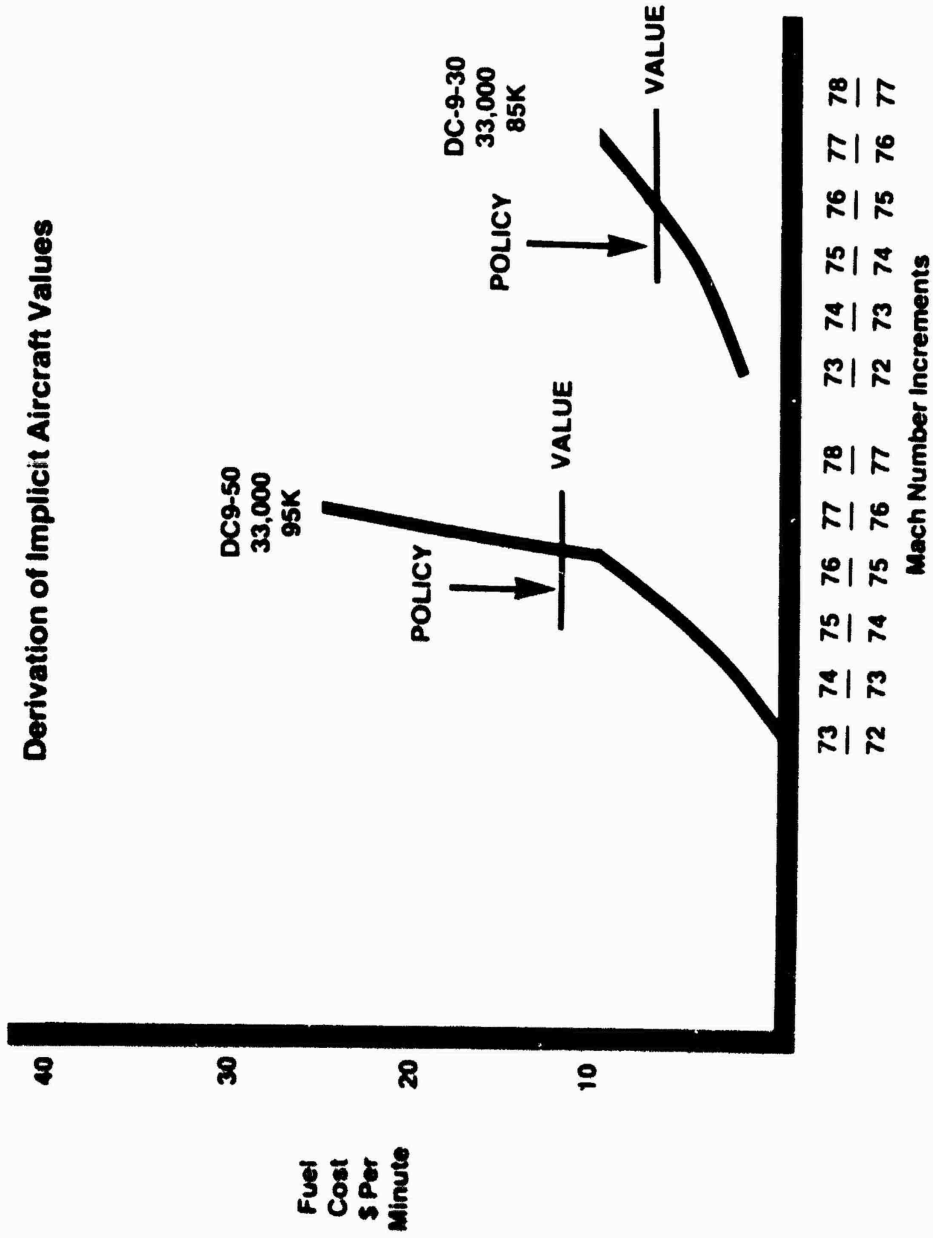

CHART VII

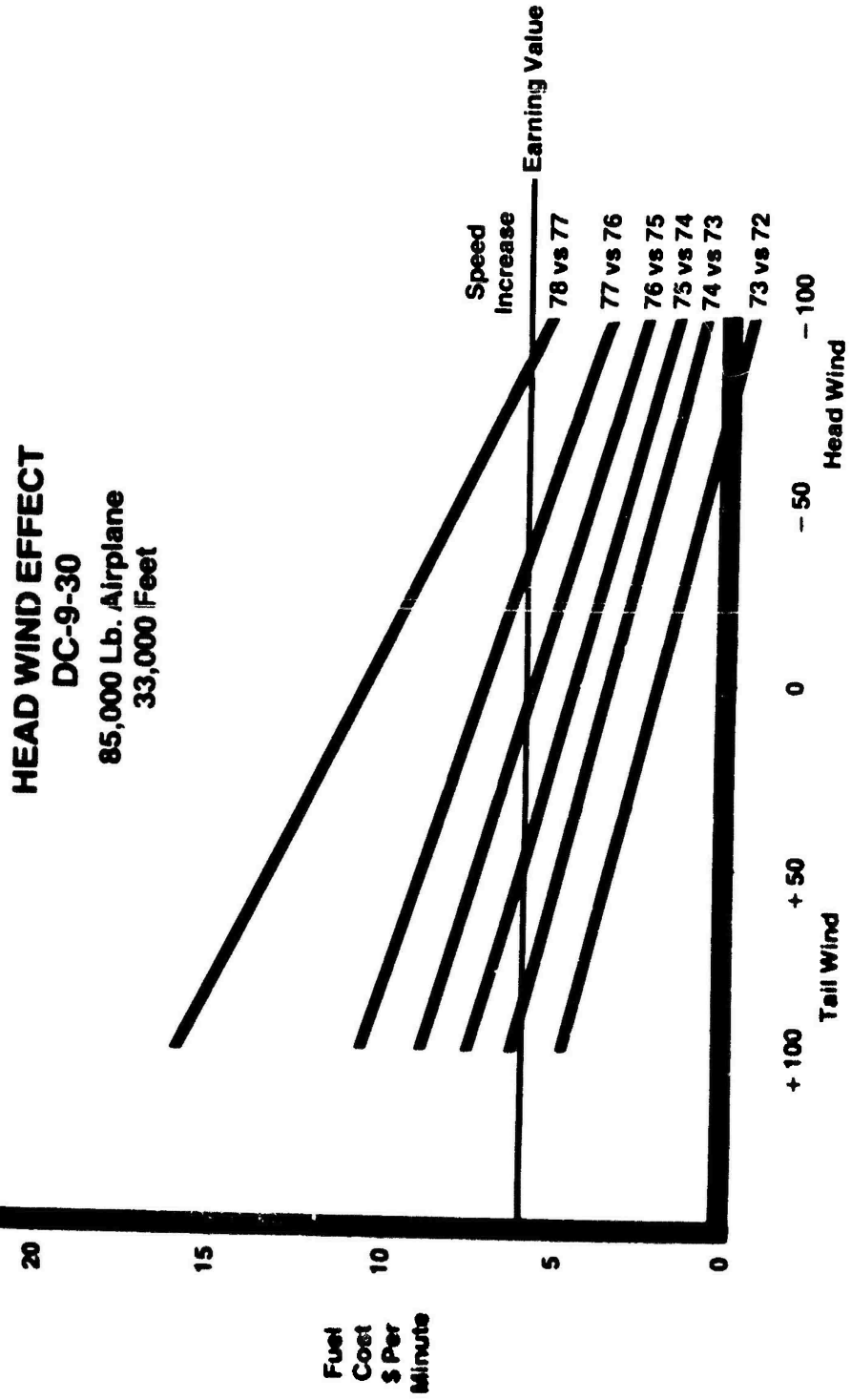

TABLE 1

**Wind Trade Offs
432 NM Trip**

DC-9-30

.7773 vs .75

Jet

<u>Fuel #</u>	<u>Time (Min)</u>
---------------	-------------------

100 Knot

Up Wind

Down Wind

+ 39

- 2.672

- 59

+ 1.122

- 20

- 1.550

50 Knot

Up Wind

Down Wind

+ 59

- 2.040

- 56

+ 1.362

+ 3

- .678

CHART VIII

DC-9

36

Slow Down ←

Speed Up →

Alt.

31

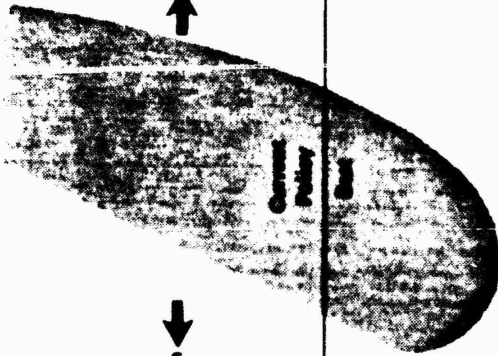

Slow Down

+100 Tail Wind

-50

-100

Head Wind

CHART IX

CRUISE POLICY

Derivation of Implicit Aircraft Values

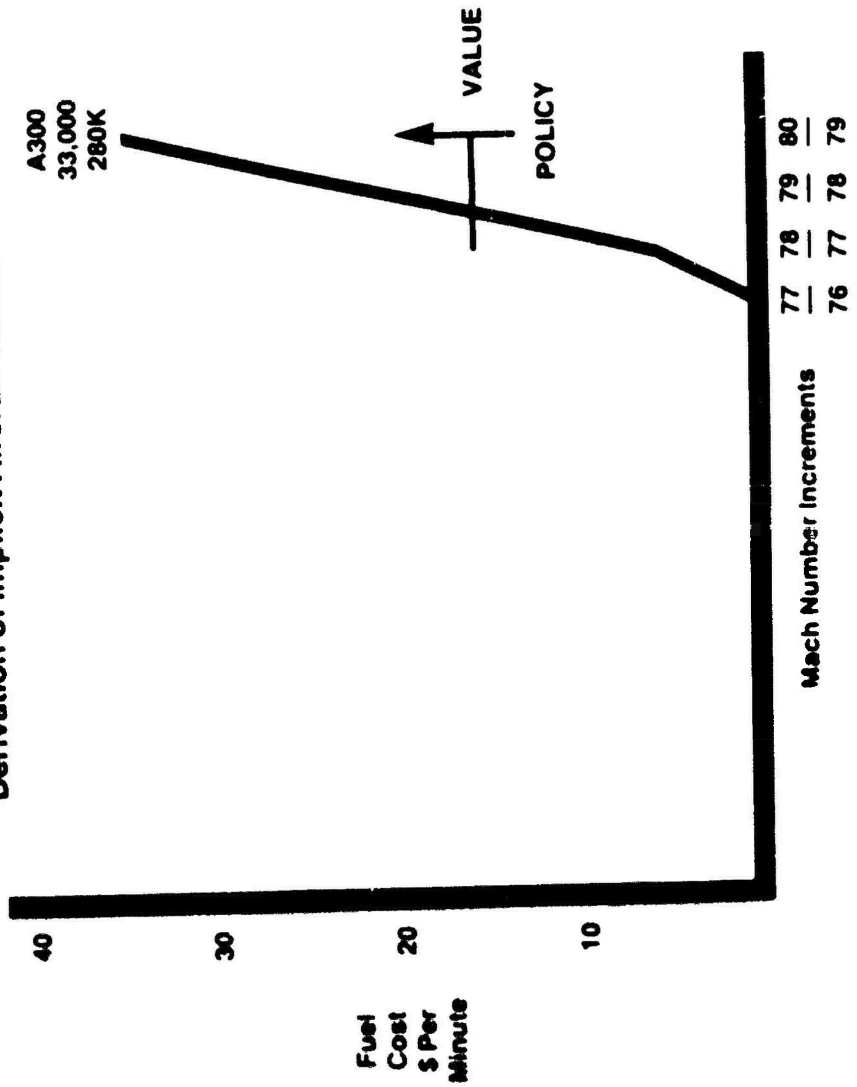

CHART X

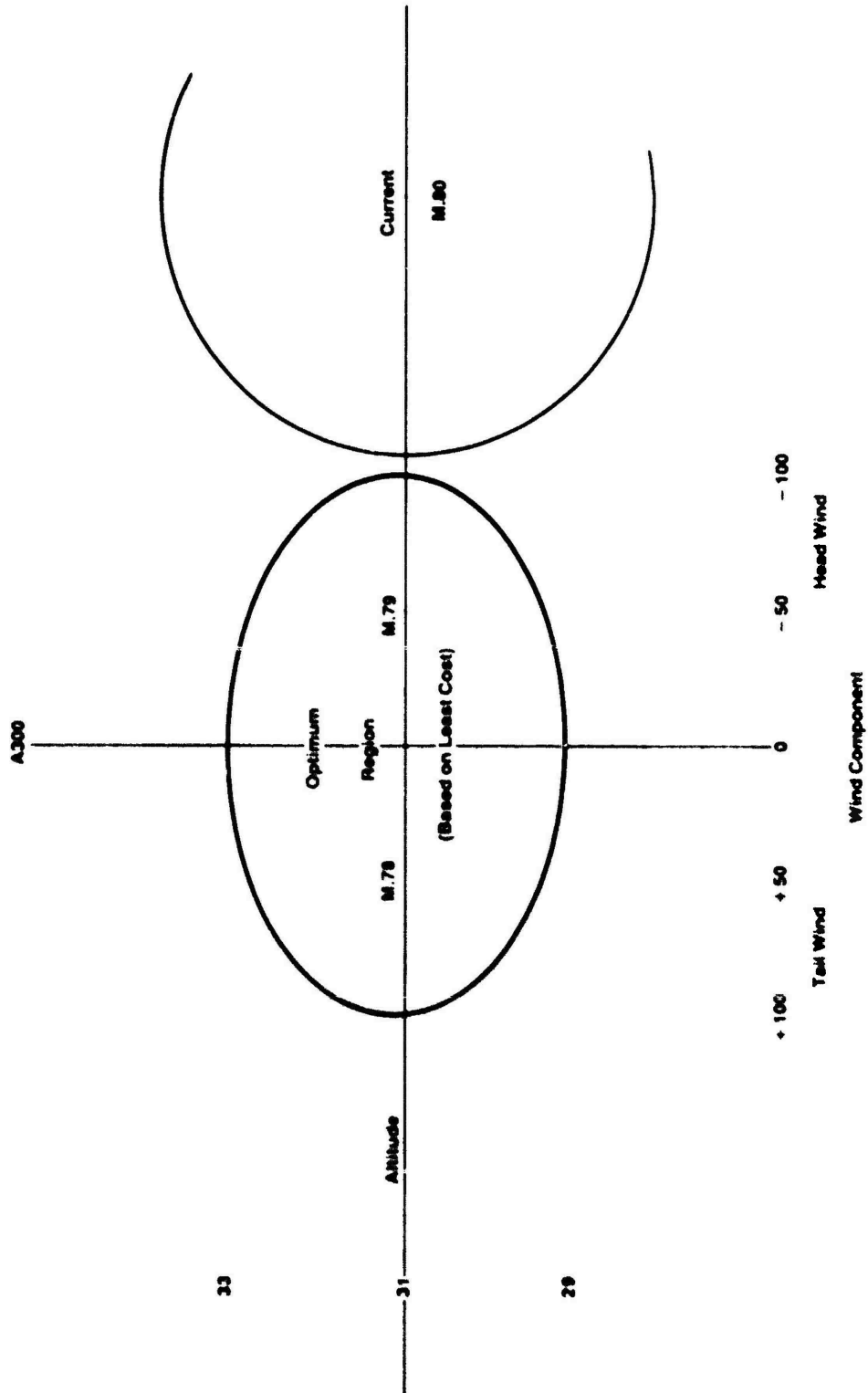

CHART XI

LEAST COST FLIGHT PLAN

Earning Value of Airplane Per Elapsed Minute
Versus
Policy Cost of Fuel Per Airborne Minute

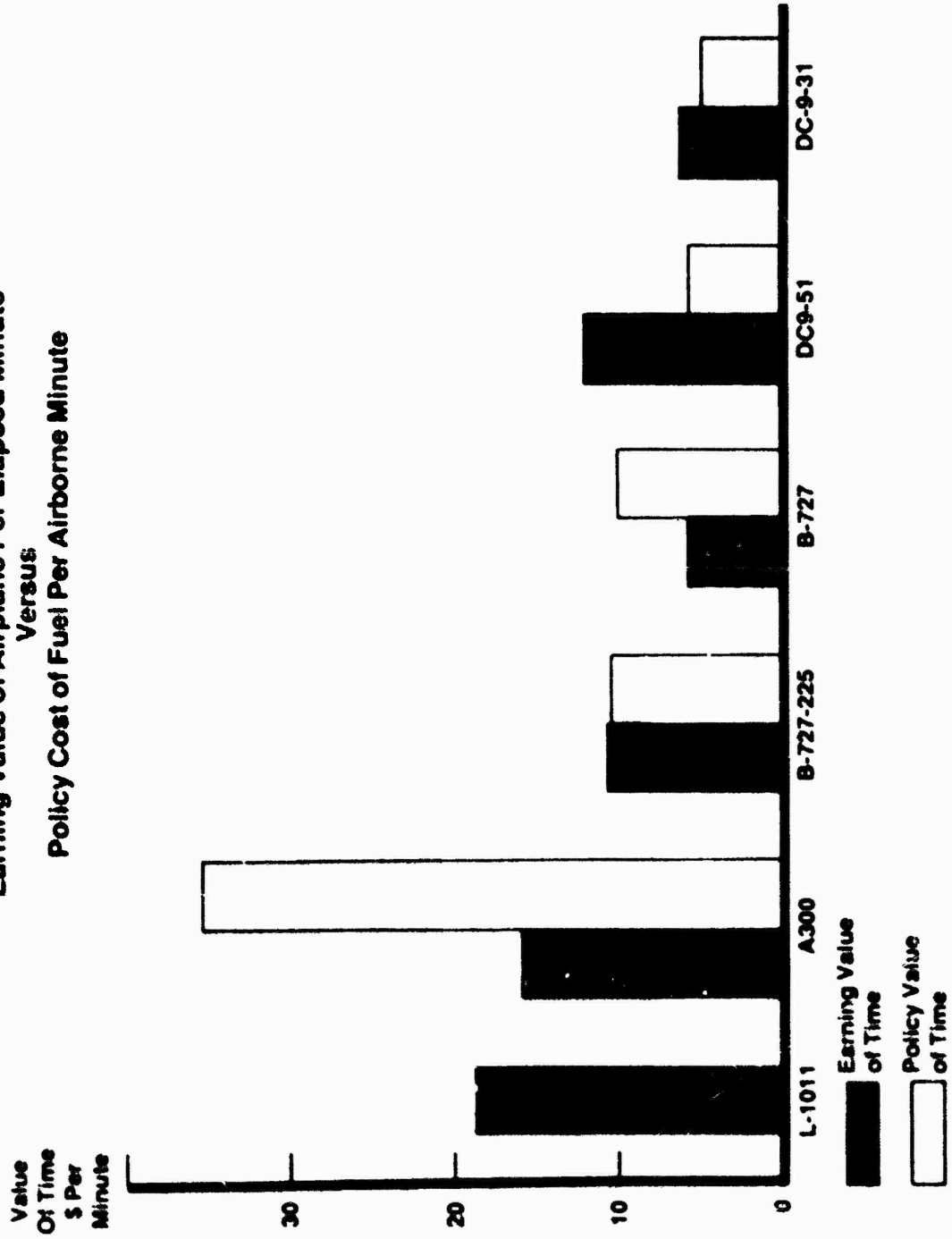
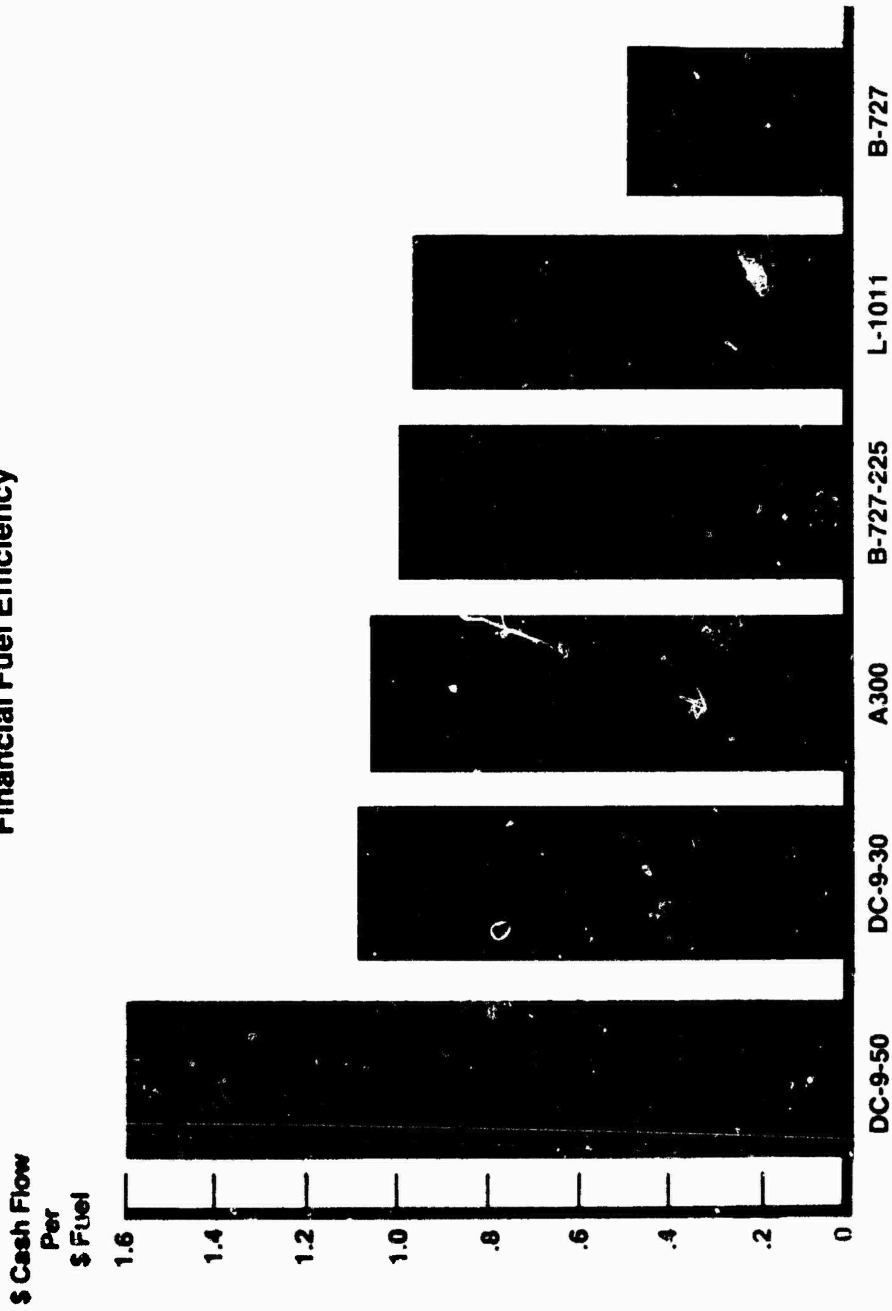

CHART XII

FUEL SAVINGS PROGRAM
AIRCRAFT OPPORTUNITY COSTS

Financial Fuel Efficiency



PILOT/AIRCRAFT FUEL PERFORMANCE EVALUATION

Gordon A. McKinzie
United Airlines

1. INTRODUCTION

Over the past day and a half, we've talked a lot about the strategies we can use to squeeze that last drop of fuel out of our operations. Now that we're quite sure we have the means and measures to save millions of gallons of fuel from our budget each year:

How do we determine how well we've done the job?

How do we really know the savings are out there?

And each of us must wrestle with the question as to how much corporate priority should be dedicated to the care and feeding of programs to tell us these things.

Just after the 1973 embargo hit, we suddenly found we had a gigantic resource management problem on our hands....that "ho hum" expense category called fuel was no longer just another burdensome "accounts payable" entry. It rapidly increased to constitute almost one-half of our total operational expense budget, and became the single highest, most identifiable cost element on the books. The paradox we found, however, was that the accountability for how we expended this resource was virtually non-existent. Other departments in our company were miles ahead of us:

We found that our Food Services Division, for example, could account for thousands of liquor minatures - to within a fraction of a percent of inventory levels - and also report trends of consumption,

by Johnnie Walker,
by Canadian Club,
by Beefeaters, and so forth -

when we couldn't even tell the burnout rate of a B-747 from that of a DC-8!

And our company accountants, those masters of the miniscule, were generating mountains of reports, and producing expense analyses on everthing from toner usage on the office copier to sick leave usage for the skycaps in Detroit, but - -

Nobody was seeing to it that our fuel consumption experience was being monitored with any sort of regularity using analytical tools which would lead to system improvements or corrective action.... And I suspect that many of you were (and maybe still are) in the very same boat.

I would like to discuss four separate areas dealing with the methods by which we determine: 1) the extent of our fuel consumption, 2) the manner in which this information can be used to forecast future fuel usage, 3) present measuring systems and parameters for looking fairly and squarely at how the competition is doing, and finally, 4) a brief word about goals and the way they can be developed and tracked in conjunction and cooperation with overall company objectives.

II. MONITORING AND ANALYSIS

Just being able to precisely measure fuel usage won't be effective unless you have identified where the results of your data collection and analysis efforts will lead. We think it's important that fuel measurement information cover these four areas, as a minimum:

Pilots - those most directly involved and responsible for the actual consumption of fuel as related to plan -- I would also include dispatchers in this grouping also, since they are at the forefront of the trip fuel planning process.

Flight Management - those charged with the administration of flying policy and the conduct of the pilots under their jurisdiction in flying their trips in accordance with specific policy and procedures.

Top Management - because as I've already mentioned, the economics of fuel now occupies a persuasive position of dominance in the strategic financial plans of our companies - the need for good intelligence in this area is a must.

Outside Agencies - such as the FAA, desperately need the type of fuel consumption information that only the airlines can provide - they too have national priorities in fuel conservation - most of which are not attainable without the input and counsel of the industry.

Looking at what we feel are the monitoring and analysis responsibilities in each of these areas:

Pilots

First of all the pilots: right up front, they directly influence good or bad fuel consumption, as reflected in their good or bad airmanship. We don't like to use the expression "throttle bending", but the message is there; pilots can do ultimate good or harm to your fuel program. They can, through individual effort and often good intuition, luck and skill, measurably enhance what is often the result of shaky flight planning or changing conditions at odds with a forecast, or, through casual neglect or indifference to the progress of their trip, totally offset the best tactical planning you have to offer. The pilot, then, in the performance of his duties, should be a prime candidate for monitoring and analysis. How you go about this, however, can have some interesting and potentially disastrous implications of its own. Right off the top, to develop a "report card" system for pilots will set you up for three possible outcomes:

You can placate those pilots who have been telling you all along that their performance has been better than the occasional shotgunning ride or proficiency check has indicated - and your data will bear this out (they have been vindicated). Or, you can stimulate the heretofore lackadaisical or unmotivated pilot who, finally realizing that a true performance measurement system is in place, feels challenged by the prospect of having his airmanship scrutinized and evaluated in competition with his peers. And this is not a naive view from the ivory tower based only on what we data crunchers are wishful-hoping we'd like to see...there are more conscientious, motivated, innovative, and fuel-savings-oriented pilots out there than we realize, and these people welcome the opportunity to demonstrate their technique and skills. But, also, we have those who totally reject and decry any attempt to be measured in any way. We aren't sure how large (or how small) this group is - they have always been referred to as "that 5 per cent", or "those few holdouts", etc., but they are indeed only alienated by any system which holds them up to scrutiny.

Unfortunately, these individuals often become quite vocal about how they've been transgressed, their rights violated, their airmanship questioned, and so forth. The advice here is to "let well enough alone": the first (and last) mistake I made in this regard was to think I could intimidate a senior Captain into not abusing our fuel policy by suggesting that he "straighten up and fly right" - I quickly found out that more subtle methods are required to address performance assessment techniques to the pilot group as a whole.

Flight Management

The best alternative, we feel, is to make local domicile management the focus for fuel consumption performance, since they are more adequately suited to translate the statistics of what we show in terms of the reality of the flying operation at hand, and to use their management techniques and pilot-to-pilot advantage to produce whatever corrective action they feel is required.

Our "report card", then, is appropriately labeled the Domicile Fuel Management Reporting System. It is, as the title implies, not pilot-directed, but group-oriented. A performance measurement of B-727 burnout in the Denver domicile could include 140 Captains, but be addressed to only two flight managers. It is this small cadre of individuals whom we look to as the real practitioners of our reporting system.

Any fuel monitoring and analysis report must contain a most basic capability: to look at the trip-by-trip components of burnout, flying time, and rate, which derive from the ingredients of burnout and time, and to be able to compare these head-to-head on a plan vs. actual basis. If you don't presently have this capability, there are still fuel performance measurement methodologies available, but they become suspect if they contain less than all the final values which each pilot, on his own, can capture. The result is a compromised product which lacks credibility with both pilots and management and quickly falls from grace as a reliable performance gauging system.

Our report has evolved over a period of seven years, first starting with a simple tabulation of burnout rate for each domicile as a comparison against a total system average rate, to the slightly more complex format shown here (Figure 1):

Here we've tried to display all the components of burnout, time, and rate as compared to plan and to develop a rating system which gives meaning to the degree of accomplishment in these areas, and which is also suitable as a goal tracking device.

Anybody who becomes involved in developing reports of this type will soon realize that the bare data don't truly reflect degrees of airmanship, but contain other external factors influencing the results which should be factored out. To not account for these influences, such as ATC delays, TCA low-altitude vectoring, and the like, is to unfairly penalize the pilot in his efforts to conscientiously fly the flight plan. How often have you heard: "I was well ahead of my plan fuel until the ATC got me in my descent". To account for the incidence of high-density TCA excessive delay and burnout, we built in a set of incremental fuel and time biases for each trip penetrating known areas of penalty. These incremental values are simply added to the basic plan values of time and fuel, which then becomes the standard for that trip, against which performance is to be measured. We label these biased values in our reporting system with the prefix "base".

The values of fuel and time bias are statistically derived from the most recent information available. Although it would be desirable to obtain these bias "signatures" from the actual month of the report, the data sample is usually too small to obtain good median values from a distribution. For our purposes, we've had the best luck with assimilating these values on a seasonal basis. Figure 2 shows a typical set of fuel and time bias values for the accumulated months in our winter season, also grouped by segment length, which appeared to have some bearing on the type of ATC penalty we were experiencing. As an example, all B-747 trips arriving into San Francisco from long haul trips (which we've classified as being in excess of 1200 nautical air miles) during the present season showed a median incremental fuel burnout in excess of plan of 1900 pounds and a corresponding excess delay of 6 minutes. These values would be used to bias the plan level accordingly in all of the B-747 domicile data reflecting SFO as a destination.

Once all this information was in hand, it became obvious that a meaningful yardstick was needed with which to rate one domicile's performance against another. What we elected to do was to look at each individual component of fuel, time and rate as it fell out of each trip, and to tabulate it according to its individual result of better or worse than plan. In other words, each of the three components could be over or under plan, yielding six pass-fail combinations which we then ranked, simply, 1 through 6. A rating of 1 meant that a trip was over in burnout, over in time, and over in rate - and would be rated an unqualified POOR. At the other extreme, flights burning less fuel than plan, while still arriving in less time than plan, and under plan rate, would be assigned a "best of all worlds" rating of 6, which we labeled OUTSTANDING. And in between are all the other combinations and shadings of performance from 1 through 6. Every trip contributes to the total domicile achievement into this ranking format. The system has caught on in a pretty big way with our domicile management, and they have taken to calling us to have their particular trips evaluated and to receive their personal "score". The calls are becoming more frequent, to the point we think we've created a monster! We use a simple bar chart system to let each fleet manager see his performance compared to other domiciles flying the same equipment, as well as his achievement to Corporate goal levels (Figure 3). On a larger note, we lump domicile performance into larger groups, since we have vice-presidents out there who also have performance objectives in the fuel area.

It's a lot of "number crunching", a lot of computer time, and a lot of paper. But we feel there is a need for emphasizing the positive aspects of conscientious fuel management, and are working toward capturing this performance in a way that will produce close to a 100% stimulation of all our pilots and remove the old fears and suspicions which have created opposition and alienation in the past. We even hope someday to be able to recognize superior individual fuel savings achievement in a public and tangible manner.

Special Reports (Corporate Information)

The same information source which we use to generate reports of a very local nature can also be used to isolate and describe fuel burnout performance in virtually every operational segment of the company. Once the basic ingredients

of fuel, time, and rate are collected and appropriately tagged to particular flights, by certain pilots, into known stations, sectors, or geographical divisions, the process only involves the sorting out of data into desired slices and groupings; the number of reports which can result from this is virtually endless. We have produced, for example, for Corporate information, detailed reports dealing with excess fueling, either due to Captains adding fuel, or the fuelers themselves overfueling as a result of sloppy procedures, as well as detailed analyses following close on the heels of experimental programs and strategies we've launched to see if expected fuel savings have really materialized. I don't subscribe to the "garbage in - gospel out" theory that anything flowing from a computer is instantly credible, but I do think that a set of computer-generated statistics which derives from a good solid assimilation of data is a convincing sales tool when new program proposals are up for review. I'm not at liberty to tick off the types of reports which we furnish routinely to our Senior Management, but suffice it to say that we're finding more of our fuel reports heading upstairs - if you've been waiting for the right cue to convince your management of the need to invest in a comprehensive operational data acquisition system - that time is now! I guarantee you that anything you or I might produce today along these lines is already overdue.

Outside Agencies

I mentioned earlier our support of outside agencies such as the FAA, and the heavy reliance they place on the industry's ability to supply in-house data for their compilation and amalgamation into their own reports and studies. The FAA, ATA, National Weather Service, and similar organizations have a real problem with capturing the impact that their jurisdictions, such as the ATC system, have on the industry without our assistance in the data area. There are really only two principal reasons why they must rely on us for help: first, the number of daily operations is so vast that they simply do not have the resources to capture all the myriad nuances of the system, and secondly, they have no idea how we are performing to our expectations; i.e., are we being helped or hindered? Only we can tell them that. One case in point I can allude to is our assessment of the profile descent and flow metering program at Denver when it first cut over in 1977. It was no big surprise to the FAA that, initially, delays were being generated, but the extent to which we were being hurt timewise did not directly relate

to the beating we were taking in adverse fuel expenditure. As this chart (Figure 4) shows, we came pretty close to telling the FAA to "pull the plug" on this operation and get back to the drawing board just before things suddenly started getting better. It can be a full time chore accommodating outside requests for data presentations of this type, but we've found that, as a rule, these dialogs are extremely beneficial to both parties in the long run.

III. FORECASTING

Although fuel usage forecasting techniques could rightfully be considered a type of "corporate need" reporting process, I wanted to treat this subject separately for the simple reason that it transcends the category of performance monitoring. Even if you had conclusive proof that your fuel conservation strategies were 100% effective and you were doing all the right things in saving every available drop, your financial departments would still need to have a good handle on what to expect for next year's fuel budget. Their biggest concern, of course, is the capriciousness of fuel price, and the relative uncertainty of the market to conform to any of the economic indicators. I know the various ways in which many of us have tried to wrestle with this problem through the years, and think I am on pretty safe ground to report that no one has yet developed a successful economic fuel forecasting model which captures all the vagaries of price dynamics. What I am sure we also agree on is the fact that the factors of flying hours, projected loads, segment lengths, and overall fleet deterioration all must come into play in arriving at an anticipated total burnout figure. At that point, then, we turn the controls over to our purchasing departments, who, through no fault of their own, can put the whole situation into an inverted spin with their multi-cut price projections, subject to change without notice.

The construction of an annual forecast level of burnout cannot rely safely on past experience, therefore invalidating tried and true methods of variational analyses based on historical trends: we're still looking for an average year, but no luck yet! The last time we thought we had a statistically pure year with amazing conformance to plan burnout, we promptly went into a two-month strike. So much for historical systems. This plot of last year's DC-10 burnout rate history (Figure 5) is typical of things going wrong: just when you think you've got an identifiable offset of plan vs. actual, something happens, through your own doing or due to

an unpredictable weather event, to radically change relationships and put things back to square one. This chart (Figure 6) is the highest form of statistical technology available to us at present, and we don't mean to sound facetious. We don't have a vertical scale; all we know is that it generally conforms to the burnout rate profile we've observed over the years for our operations: the summer peak (high loads, hot weather), the Christmas buildup (enhanced by colder weather, but offset by loads, weather delays, and strong winds), then the combination Easter/back from school bulge. As much as we try to laugh this type of black magic out of the data, the old profile keeps reappearing; it's only the vertical placement of this trend chart that keeps us awake nights.

One approach we've used with some success through the years is to develop monthly rate forecasts using the year-end actual value of rate and incrementing (or decrementing) forward on a monthly basis from that point. The "delta rate" adjustment value is based on the variation of projected payload and segment length, and determined from analytically-derived values of burnout rate sensitivity with payload and time.

I won't dwell on the means we use to derive the values, except to say that any flight planning system or good set of engineering data will quickly yield the slope values needed to calculate the incremental changes in burn rate. Figures 7 and 8 show the characteristics of these slopes for the payload and trip length variations of one fleet type. The only caution here is that all perturbations of flight conditions must be considered, and it is unlikely that any two airlines will come up with the same sensitivity factors. Normally, one simple slope factor for a range of payload or trip length variation will fall out, but all possible influences of winds, temperatures, direction, and the like, must be considered.

Figure 9 shows the sensitivity coefficients we have used to reflect average burnout variations for 1981. A 10,000 pound (increase) payload variation is worth about 420 lbs per hour of burnout rate change, and another 300 lbs per hour rate impact would be generated if the average segment length was lengthened by one hour. This chart is somewhat oversimplified: in reality, the slope factors themselves change as the nominal values of average trip length and payload vary from month-to-month based on the nature of load and flying time forecasts supplied by the trip planning strategists.

After all this is done, we still superimpose our hip-pocket "profile" over this analytical tool. More often than not, a trend which did not "conform" would be re-evaluated and some subtle discrepancies usually discovered.

IV. COMPETITIVE MEASUREMENTS

There seems to be a growing popularity within management to assign performance-related goals to any type of operation whose results can be quantified, and the area of fuel burnout performance is especially ripe territory in today's environment. We have long sought a measurement system which will truly reflect the productivity of our flying operation which relates directly back to our own pilot population and their airmanship skills - at the same time, we would like other airlines to deploy the same measurement criteria so we can establish ourselves in some type of competitive ranking. We don't use similar systems, however, and that's where the trouble begins. Standard data sources, such as the CAB Form 41 information, has been frequently criticized for its lack of precision and inconsistency when used for broad scale competitive comparisons. In all fairness, however, the quality of the data has improved through the years and certain parameters, we feel, do constitute valid measurement indices - while whetting our appetite for searching out new and innovative means to represent comparative information in more meaningful terms. I have no new suggestions to make along these lines, only a few comments which might be of general interest to your own investigative efforts in this area.

The subject of fuel gets pretty short shrift in the trade publications, and the best we can do here is look at macro-levels of a fuel consumption figure which is a mix of purchased gallonage divided by flown hours, Figure 10. There is no good reconciliation to true aircraft burnout performance, and the factors which influence the levels of this parameter are so unique and different among competing airlines that, unless your airline comes out on top, there is an immediate reflex to castigate this reporting system as non-representative and invalid. Perhaps such an indictment is justly deserved, with a hodgepodge mix of different aircraft weights, engines, segment length, and the geographical impact of different ATC centers and TCA's. Also important are the differences between airline flying policies and the value placed on burnout performance in relation to direct operating cost. Fuel policy can markedly alter the apparent burnout performance of one airline compared to another.

The comparative parameter of revenue passenger miles per gallon, Figure 11, begins to reflect fuel efficiency as related to lift, but still falls short of the mark so long as airlines remain locked into dissimilar patterns of flying and there is little mobility in changing gauges of equipment within route systems.

Another interesting comparative tool suggested by the Aerospace Corporation makes use of a scheme in which standard CAB Form 41 components are grouped in order to reflect business cycles referenced back to a "year of interest". This parameter is fleet sensitive, and appropriately labeled "corrected miles per one hundred gallons", Figure 12. The formulation is not complex, and has proven useful in our comparisons during periods where our loads have taken large swings in relation to burnout swings. The only drawback we've found in trying to use this concept on a more widespread basis is the fact that a considerable task is involved in referencing data from other airlines back to the baseline "year of interest". Also, the likelihood of obtaining calculated values "pre-referenced" from other carriers presently is quite remote. As an on-going trend evaluator, it serves well as an in-house tool, but, until standardized conventions for data reporting are established on an industry-wide basis, its routine use would represent a sizeable data reduction task.

With the data available to us at present, we still endorse the familiar revenue ton-miles per gallon methodology, as shown by the dotted line in Figure 13 for our B-747 fleet. Although this representation will not reflect business fluctuations as contained in the "corrected miles per one hundred gallons" system, it nevertheless produces, for specific fleet types, a normalization of flying pattern variations consistent with load. I've shown a revenue tons per mile trend superimposed on the RTM per gallon line to show the consistency which exists between an expression of both routing and burnout efficiency, but the use of the per-mile index has little importance to us as a strategic monitor of fuel performance.

V. GOALS

We've all been exposed to the rising tide of new management techniques which key strongly on goals and goal-setting. We have no revelations or innovative approaches on the subject to pass along, except to suggest that the data banks and bases you are building in the fuel performance area will

stand you in good stead as a means to scrutinize the past before future expectations are imposed. The degree of "stick and carrot" to be layered in on top of present performance is a decision which only a tuned-in management can assess and assign. Non-achievable goals quickly intimidate and discourage the marginal performer, and give him little incentive for trying to improve previous levels of performance. In our own Domicile Fuel Management Reporting System, we found that reasonable levels of performance expectation could only be determined after re-running an entire year of accumulated data, on a monthly basis, to verify that our goals had the weight of experience behind them, as opposed to seemingly arbitrary methods of goal-setting which are inevitably challenged and often times embarrassingly difficult to justify.

VI. SUMMARY AND CLOSING

What I've discussed with you this morning represents only the systems and approaches in the fuel data management area which we have concluded represent a reasonable and useful deployment of data sources at hand. If a single message is to be left here this morning, I think it would be the realization that most of us are somewhat behind the power curve in developing fuel performance reporting systems to the same degree of sophistication enjoyed by most other resource monitoring departments in our respective airlines. And it's only because we never thought that fuel would be accelerated so quickly into the spotlight as a major swinger to our economic well-being. The prognosis for "things not getting any better" has already been cast: there is a clear need to establish, at the earliest opportunity, programs which will produce timely portrayals of fuel burnout performance through comparative analyses and goal-compatible reporting formats. You should make this one of your first priorities when you get back home.

While I've been up here, our industry has burned up almost a half-million gallons of fuel, plus or minus a few hundred thousand gallons. With that kind of appetite and the current conditions affecting our supplies of this here-today-gone-tomorrow resource, we must make sure that all the strategies we've discussed during this symposium be given every chance to prove their merit, and that accountability systems for how and where all this fuel is being consumed be given immediate development priority.

FEB 21, 1981

DOMESTIC PERFORMANCE AUDIT - FUEL
MONTHLY BURNOUT ANALYSIS BY FLEET TYPE
*** MANAGEMENT SUMMARY ***

(1ST QTR) JAN-OCA 8-727

GROUP	B/O	PERFORMANCE LEVEL	(1) NO. OF TRIPS	(2) PCT OF TOTAL	(3) BASE FLT BURNOUT (LBS)	(4) ACTL FLT BURNOUT (LBS)	(5) BASE TIME OFF-ON (HRS)	(6) ACTL TIME OFF-ON (HRS)	(7) BASE B/O RATE	(8) ACTL B/O RATE
1	OVER	OVER	62	4.5	1,549,200	1,677,700	177.65	183.26	8,721	9,155
2	OVER	UNDER	44	2.4	935,600	954,100	110.55	109.36	8,463	8,724
3	UNDER	OVER	37	2.0	669,300	655,400	79.24	76.56	8,446	8,561
4	OVER	UNDER	305	16.7	5,062,600	5,282,300	575.02	627.94	8,004	8,412
5	UNDER	OVER	849	46.5	13,234,000	12,624,200	1,521.60	1,577.99	8,697	8,000
6	UNDER	UNDER	589	27.9	7,991,700	7,364,400	932.07	914.73	8,574	8,051
		TOTAL	3,026	100.0	29,442,400	28,550,100	3,396.15	3,489.87	8,669	8,183

PERFORMANCE RATINGS ***	(9) NO. OF TRIPS	(10) PCT OF TOTAL	(11) DIVISION PERCENT	(12) SYSTEM PERCENT
POOR - GROUPS 1 & 2	126	6.9	5.5	5.6
ACCEPTABLE - GROUPS 3 & 4	342	16.7	15.6	16.1
OUTSTANDING - GROUPS 5 & 6	1,350	74.4	78.9	78.3

*** OVERALL FLEET SCORE **	64
** DIVISION FLEET SCORE **	67
**** SYSTEM FLEET SCORE **	66
***** SYSTEM FLEET GOAL ****	66

Figure 1

**TYPICAL BIAS VALUES
LONG HAUL TRIPS
Winter 1980-81**

	<u>Fuel - Lbs.</u>	<u>Time - Minutes</u>
CLE (B-727)	700	2.4
JFK (DC-8)	400	3.0
LAX (B-747)	1,900	6.6
ORD (DC-10)	600	4.2
SFO (B-747)	1,900	6.0

Figure 2

**FUEL MANAGEMENT REPORTING SYSTEM
COMPARATIVE DOMICILE PERFORMANCE**

..... Annual Goal

JANUARY 1981

**DOMICILE
FLEET
SCORE**

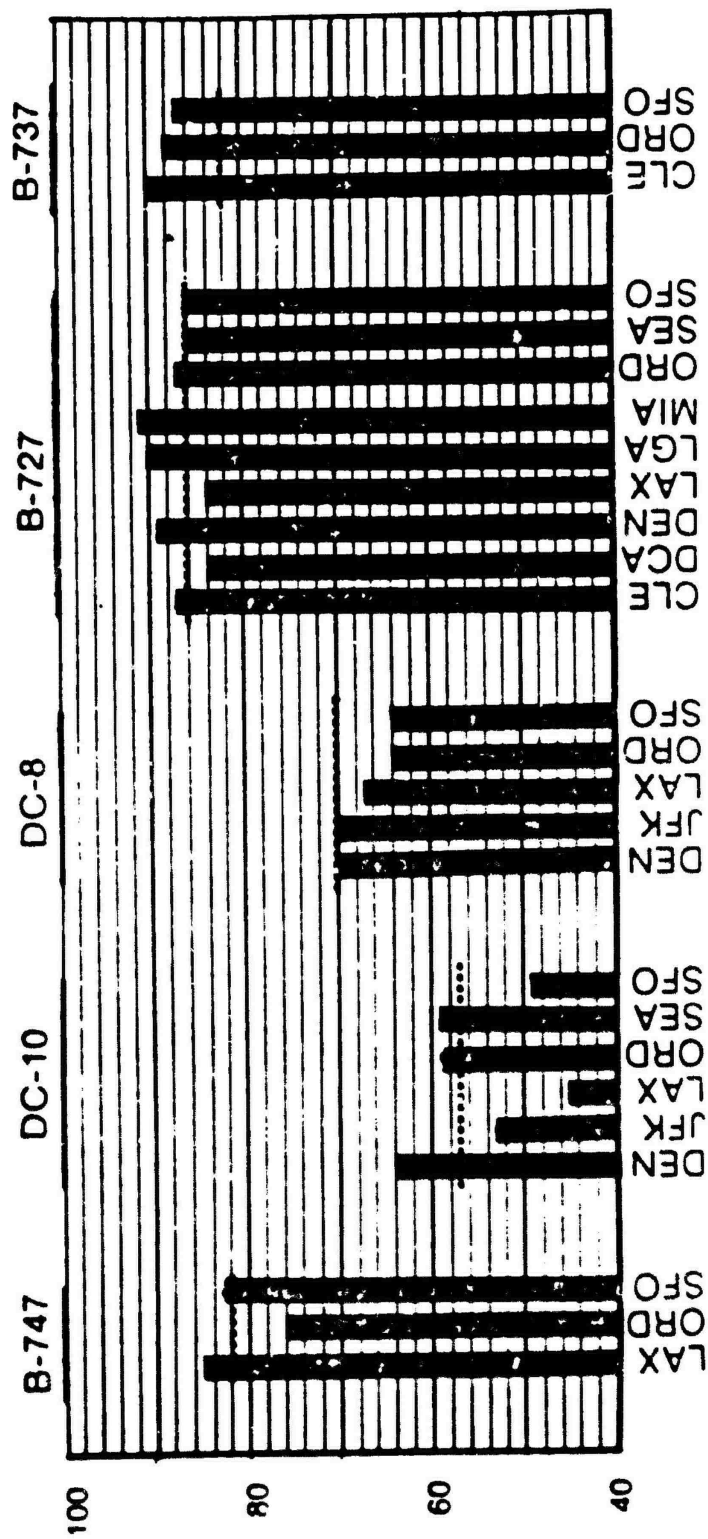

Figure 3

DENVER

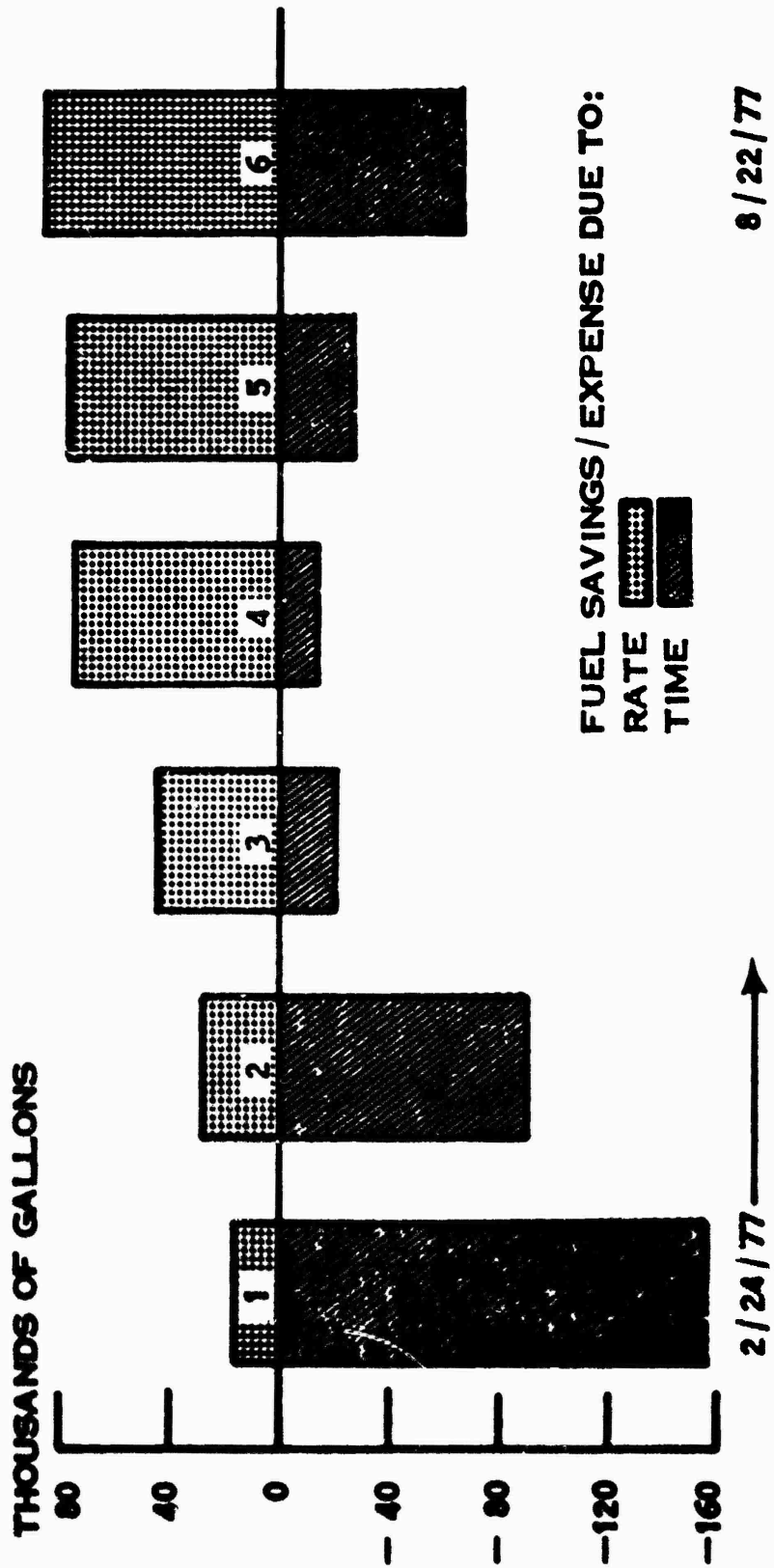

Figure 4

DC-10

PLAN VS. ACTUAL BURNOUT RATE

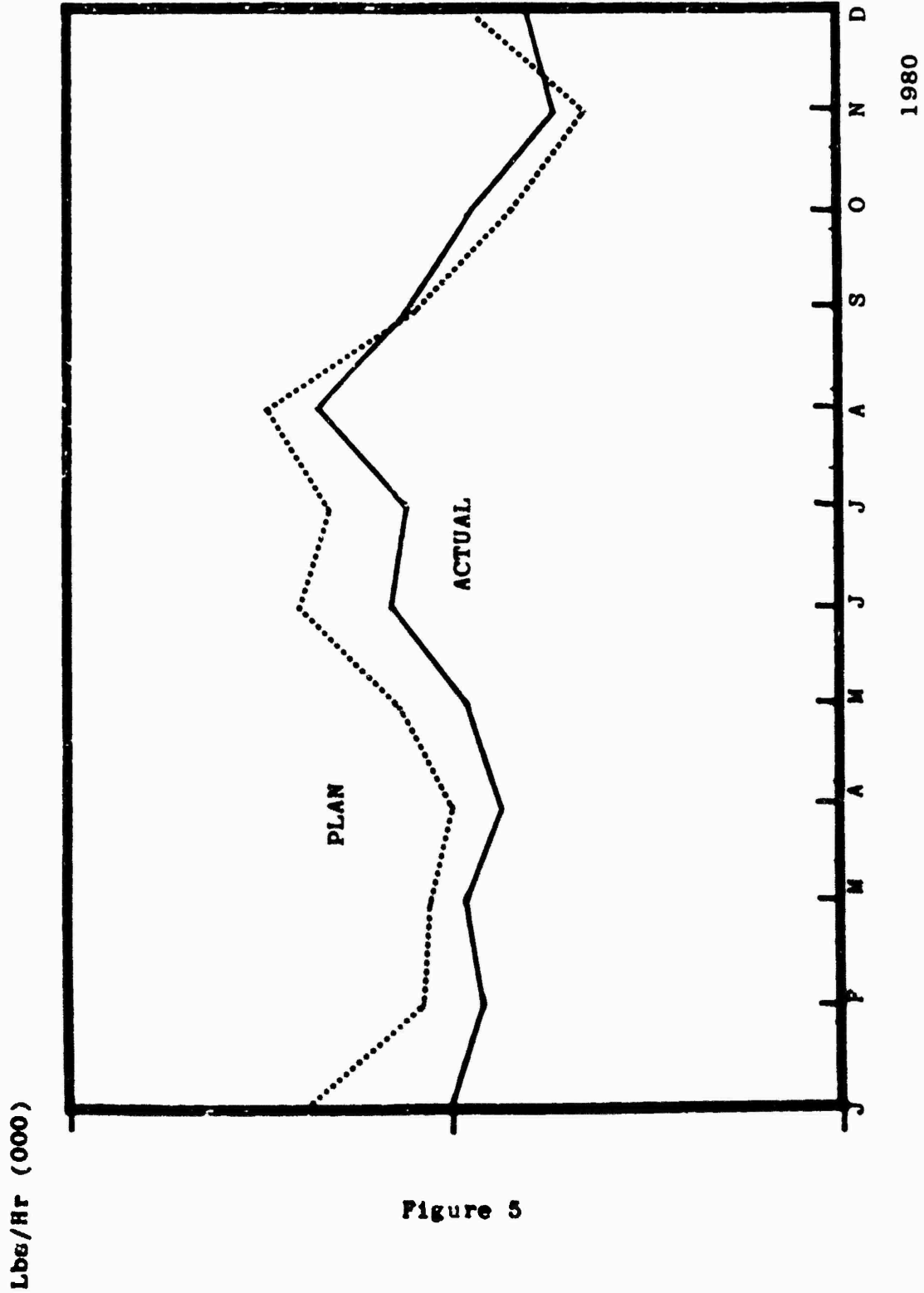

Figure 5

MONTHLY BURNOUT RATE PROFILE

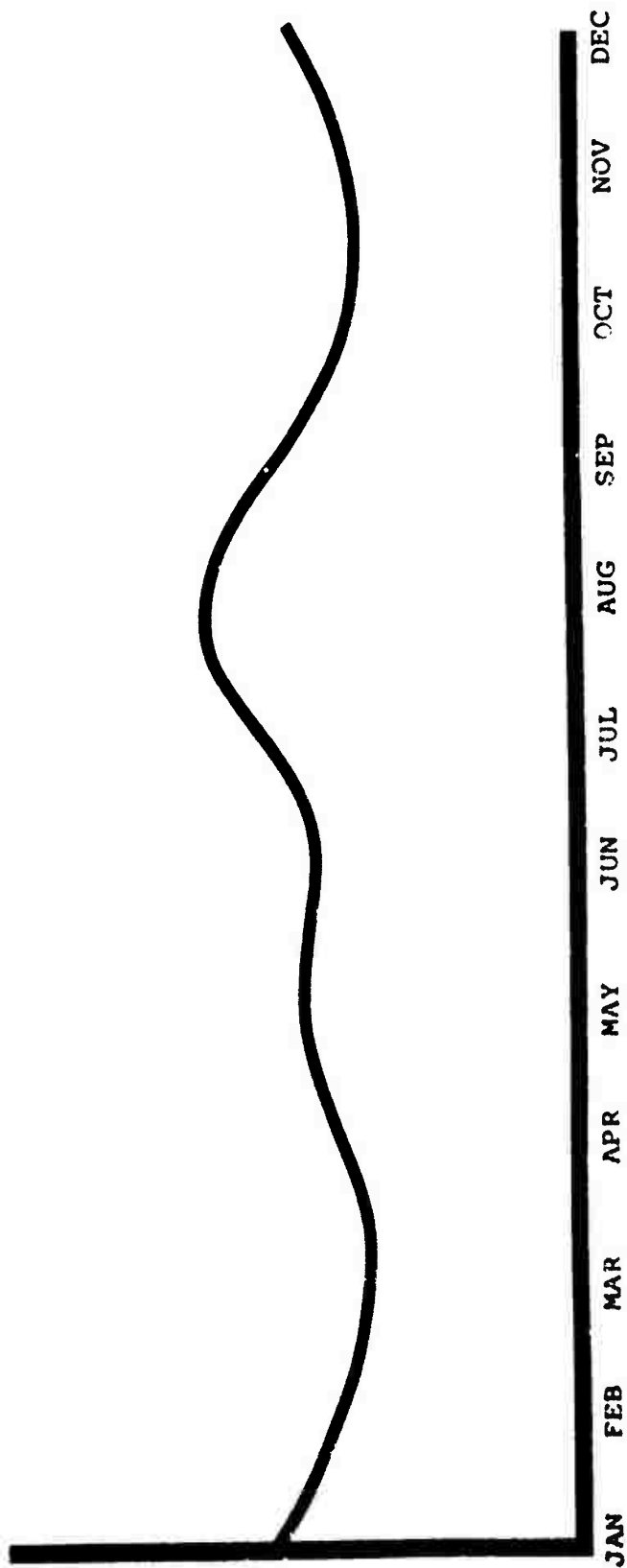

Figure 6

B-727-200 PAYLOAD-BURNOUT RATE SENSITIVITY

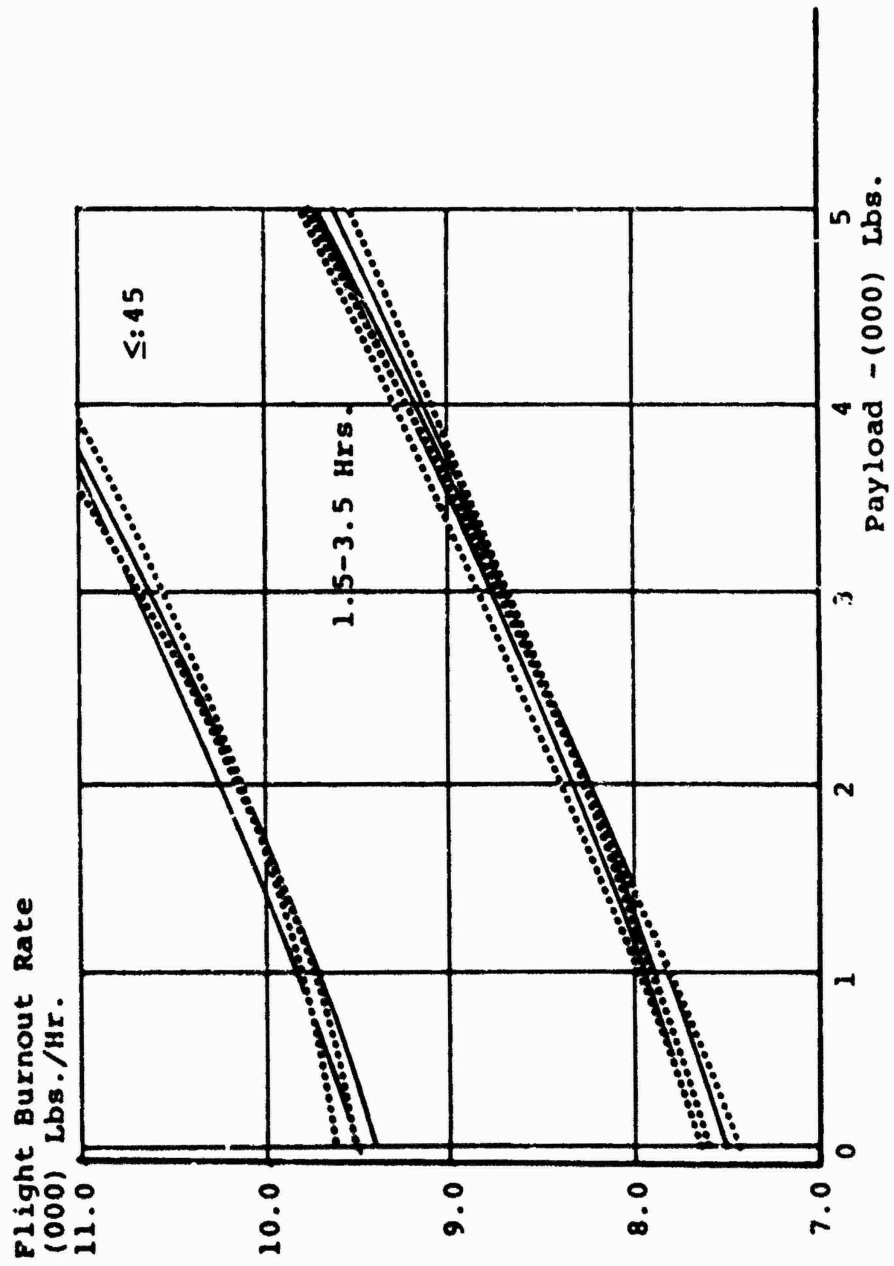

Figure 7

B-727-200 TRIP LENGTH-BURNOUT RATE SENSITIVITY

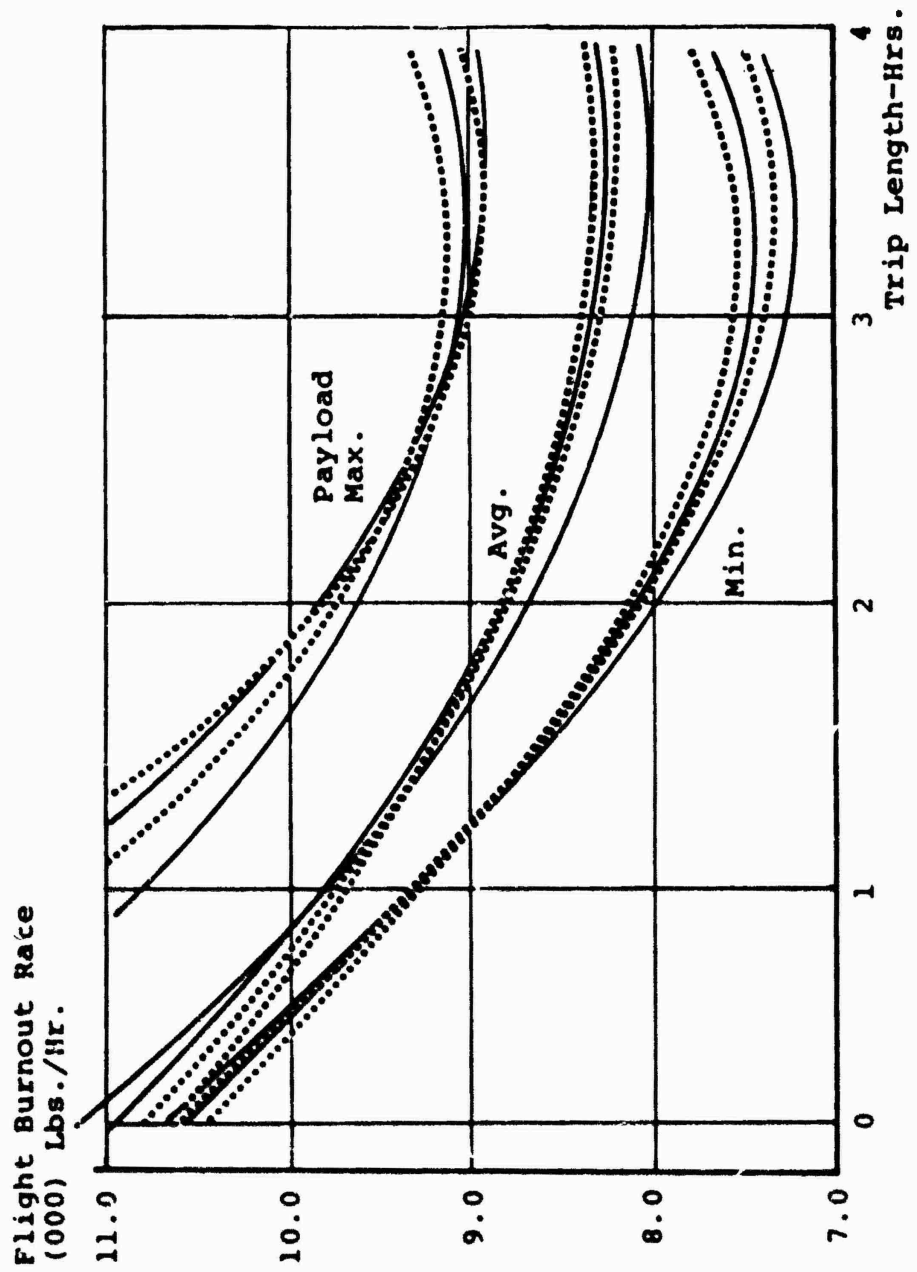

Figure 8

AVERAGE BURNOUT RATE PAYLOAD-TIME SENSITIVITY

(Average 1981 Segment Length & Payload)

Fleet	Payload Lbs./Hr. / Lb.	Time Lbs./Hr. / Hr.
B-747	+.0420	+300
LC-10	+.0325	0
DC-8-61	+.0450	-175
DC-8F	+.0175	0
B-727-100	+.0430	-380
B-727-200	+.0630	-900
B-727-200A	+.0615	-303
B-737	+.0370	-690

Figure 9

B-747 18 MONTH AVERAGE

GALLONS/HR.X 100

42

38

34

30

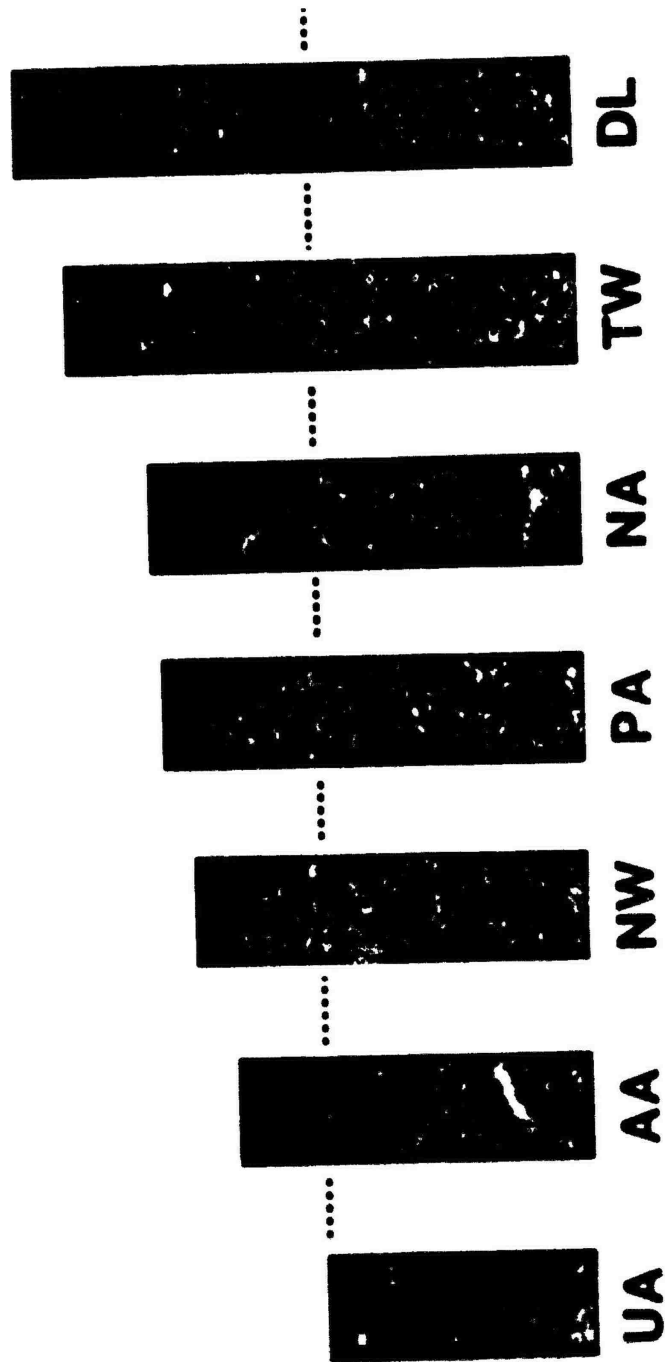

Figure 10

FUEL BURN OUT EFFICIENCY B-727-200

2ND QTR. 1978

HPMS/GALLON



Figure 11

$$\text{CMPHG} = \frac{(\text{AS})_{31} \times 10^6}{(\text{ATR})_{25} (\text{BTA})_{26} (\text{GPBH})_{35} \left\{ 1 - \left[(\text{RTPAM})_{37} - (\text{RTPAM})_{37}^{\text{Base}} \right] (2000) \frac{(\Delta F/\text{FO})}{\Delta W} \right\}}$$

Figure 12

LUNCHEON REMARKS

The Honorable Dan Glickman, Chairman
Transportation, Aviation and Materials Subcommittee
Committee on Science and Technology
United States House of Representatives

April 3, 1981

I appreciate very much the opportunity to speak at this Symposium. I am sorry that I was a bit late. We had to navigate in a new electric vehicle through cherry blossom traffic and it shows you that the best laid plans of mice and men can go awry when you have several thousand tourists from every place from California to New York coming here to look at the cherry blossoms. I am pleased to be here right now.

This energy problem or crisis or emergency reminds me of a good news, bad news story. Since you are all in Washington, it is a Washington good news, bad news story about the time that our good friend former Chairman of the House Ways and Means Committee, Wilbur Mills, fell into the Tidal Basin. You all remember that. Of course, that was very embarrassing for him and of course he was worried that the story was going to be reported all over the country. Anyway, they fished him out of the Tidal Basin and they asked him what he was doing with this young woman named Fanny Fox? He said she had been a long time family friend. They asked where was his wife? He said she had broken her foot and could not be with him tonight.

The good news, bad news part of the story is that immediately thereafter, two of Wilbur Mills staff went to visit Mrs. Mills in her apartment house in Arlington. They knocked on the door and they said, "Mrs. Mills, how are you?" She said, "Fine." They said, "Mrs. Mills, we have some good news and bad news for you." She said, "Wonderful. What is the good news?" They said, "The good news is that your husband has been found drunk in the Tidal Basin with one of the world's most famous strippers and her picture will be on the front page of every newspaper in America tomorrow." She said, "Oh my God, what is the bad news?" They said, "Mrs. Mills, the bad news is we have come to break your foot."

(Laughter.)

I submit that the bad news is not quite all that bad. The bad news is that prices of energy keep going up. They may stabilize for a bit but I do not think that we can realistically look at the day when they are going to fall for a long time.

The good news is that some efforts that we have been making on conservation and the development of alternative fuels generally, I think, have been proving to have some dividend value to us. It is my hope that those efforts can continue.

The importance of this subject is obviously critical for all aspects of the transportation sector. The transportation sector uses over half of the petroleum consumed in the United States. While it is obvious that civil aviation is not a major part of that factor, using only 8 percent of that 52 percent, in the economic sense, petroleum is the lifeblood of aviation.

All you have to do is look at the price of jet fuel, rising from about \$.10 per gallon to \$1.00 per gallon today. Fuel costs are approaching nearly 50 percent of the operating costs of U.S. airlines. Profits which are necessary to expand on the existing air systems and to buy new airplanes have been adversely affected. 1980 was the worst year in history.

I was looking this morning at U.S. corporate profits. In 1980, the Exxon profits of \$4.8 billion were larger than all of the airlines in the United States put together. In fact they were about two times the size of the whole airline industry.

What I am saying is we have got an industry whose livelihood has been affected by a lot of reasons but the primary reason is fuel costs and fuel capability. This of course has enormous effects, as you know, on competition. Fuel inefficient aircraft will not be competitive. We have seen that Airbus Industries is already the number two producer of wide-bodied aircraft and they are making enormous strides to compete with our domestic manufacturers.

As of December 1980, Airbus had sold nearly 500 airplanes. Another big order by Eastern was announced recently. The share by Boeing, Douglas, and Lockheed of worldwide commercial market may decline from 95 percent to less than 80 percent by 1990, based on an Oppenheimer and Company study.

Even more important is the significance of the market that will go to foreign manufacturers in the commuter market and in the small aircraft market. There the U.S. industry could be significantly effected, particularly because of the advances that some of these companies have had in building fuel efficient commuter aircraft.

So that means that we have to have the best technology. That means that we have to have the best fuel efficient technology. I understand that the purpose of this symposium is to provide a forum for exchanging ideas on ways to save aviation fuel. I applaud you for that.

My subcommittee of the House Science and Technology Committee primarily deals with long-term issues of fuel efficiency. Where should the government and the private sector be spending their money to come up with fuel efficient aircraft, to use alternative fuels, to build lighter aircraft, to use composites? All of those kinds of issues will make the job easier 15 or 20 years from now, but many of the things that we do will have relevance quickly, today.

One of the things that I regret, to be honest with you, is the fact that in our efforts to reduce the budget we have virtually eliminated budgets for alternative transportation systems utilization and have virtually, maybe as a matter of government policy, eliminated conservation techniques. Conservation needs to be a part of our energy policy. I do not think that is very smart business and I believe that

much of this can be accomplished without any additional budget authority. Conservation as an energy technique cannot be put under the rug with the hopes that we are going to produce our way out of this mess we are in. I hope we will produce as much as we can, but coming from an oil producing part of the country, I can tell you right now that we are dreaming false dreams if we think we are going to produce our way totally out of this energy crisis without keeping an emphasis on conservation methods. I hope that the private sector will continue these kinds of things.

I thought you might be interested in a few of the issues that our subcommittee has been involved with in terms of long-term technology to help U.S. aircraft companies become fuel efficient.

I suppose the first thing that we have funded over the years through NASA is the Aircraft Energy Efficiency Program, the ACEE Program. That has been authorized and funded. We have authorized \$500 million over the last ten years. It has many components to it. There is the engine components improvement program, NASA's sponsorship of 16 product improvements to existing turbo-fan engines. NASA estimates a fuel savings of 3 billion gallons over the next 25 years and the government will get almost all of its money back because of a recoupment clause in the contract.

This subcommittee this year just authorized a program called "prop fan," at an elevated level of approximately \$18 million. This will allow NASA to do research in cooperation with the industry to see if we can develop advanced propellers that will allow an efficient cruise at Mach .8. Hopefully this will prove more fuel efficient than existing turbo fans.

While the airlines were initially skeptical about returning to props, some are now enthusiastic about it. Hopefully we will be able to turn this into something that will produce a new generation of fuel efficient aircraft, primarily for the short-haul market of 1,000 miles or less.

This, again, is a program that we pushed because we felt it was necessary for NASA to be involved in shorter term efforts to help our industry find answers to the issue of energy efficiency.

We moved ahead this year on the composites program. Up until now NASA's program has emphasized secondary and medium structures, rudders, ailerons, elevators and stabilizers.

Our subcommittee added \$4 million to begin work on larger structures like the wing box. This will require more money in future years and a fuel savings of between 10 and 15 percent are possible.

We also have been involved in efforts to reduce the delay in the air traffic control system. All of the advantages of new technology, new fuel efficient engines, and new composites will be quickly nullified if the forecasted increase in traffic delay is realized. The same thing is obviously true of the automobile. If it is going to take me 40 minutes to get from Capitol Hill to here, then maybe some of the fuel efficient technologies are not worth so much. That is why we have got to look at the air traffic control system.

These delays cost over \$1 billion in 1979. About half of this was fuel. It is estimated to cost five times that by the year 1985. With only a two percent growth in traffic at major airports, this will increase astronomically in the years to come. This is another area that requires a great amount of work both by NASA, the FAA and the private sector.

Another very important step is the automation of the air traffic control system. This will allow aircraft to use all of the sky, not just designated streets or airways. It will require some major expenses. The replacement of the present enroute computers, these IBM 9020's will cost nearly \$3 billion.

There will be further costs to implement automation features, such as the automated enroute air traffic control, which will allow direct routing and automatic clearance generation. It will also reduce the need for more controllers. This program, which should be very important to the industry, will be met by issues on the financial and budget side. How many dollars should we spend out of the airways trust fund? Should all of this money go to these new kinds of things or should it go to some of the operational things. These will be issues that Congress will be very much involved with in the next few years.

Other issues include increased airport capacities. Those are not susceptible to technological solutions but more a problem of finding more real estate. Work is going on in areas regarding reducing aircraft spacing, weight turbulence problems and improving landing and taxi procedures.

Now let me comment on one other thing. I believe very strongly in using NASA expertise to develop advanced fuel efficient technology for the automobile industry. Cars and trucks use nearly 40 percent of the oil in the U.S. Almost all of our automotive research is going into meeting regulatory standards, 1985 standards on fuel economy and emissions.

I believe very strongly that the government should help the automobile industry with long-range R&D as it does in the aviation industry. I do not want to see the government build cars for us but I believe that they can have the same kind of relationship doing basic research to help GM, Ford, Chrysler, American Motors, and any other

automobile companies that come along in the same way that we have been involved with Boeing, Lockheed, Douglas, Pratt and Whitney, GE, and everybody else in the manufacturing business.

Therefore, I have been involved with other members of the subcommittee to try to use NASA in the automobile area and to use the model of NASA in the aeronautics area to come through with a partnership between government and industry to try to build fuel efficient cars. Why NASA? NASA seems to be the only possibility for a program that includes both basic and applied research. It has no regulatory responsibility. It understands how to get its research results into useful products. It has experience in auto technology. Most of the DOE work now in auto technology is done by NASA. Its facilities are in place and it has the best technical talent in the United States.

In any event, this is just something for you to think about in terms of what the future role of the U.S. Government should be in the whole area of basic research.

I would like to end with two basic things and open for a few questions. It is very important. The aeronautics industry has proven that research produces dividends. We have spent more dollars and have had more brains going into the development of airplanes than any other country in the world. If it were not for agriculture and aviation, we would have an enormous trade deficit.

I would hope that in our zeal and efforts to deal with the economic issues of inflation, that we do not forget the role that research has in the long-term development of this and every other industry in America.

Recently I was in Japan and I met with people associated with their Minister of International Trade and Industry. I asked him why do you have so much productivity? Why do you produce goods at a cheaper cost? What do you do that you think we should do?

The first thing that he told me was that in America, because of a variety of issues, you are concentrating too much on the short-term and you are forgetting about the long-term. Maybe it is because your companies, he said, need to concentrate on what their next quarter earnings are going to look like and not about what the society is going to need in 1990 or 1995. He said we, on the other hand, have learned that we can help our companies achieve long-term results if we think they are going to be effective.

The second thing he said was it seems that you tend to emphasize and subsidize your losers, not your winners because your losers are the ones that come to your government for help, for bail outs, but your winners do not. He said it looks to me like you need to switch

your priorities and help your winners. It is interesting that Japan has one of the highest bankruptcy rates in the world because they let their losers go down the tubes and maybe we do not want to pursue that kind of methodology in our economy.

It just struck me again that if we do have a winner in America, it is aviation. It is aeronautics. We are the dominant factor in the world. I do not think we are going to lose that in the large transport area but unless we look to the year 2000 and 2010, there are going to be a lot of companies in this world that are going to be able to pick up some of that technology.

I fear that maybe we have begun to lose it in the field of commuter aircraft and small airplanes. I think we need to turn that around and I would hope that through near-term efforts on conservation and long-term efforts such as what our committee is trying to do, we will continue to make the American aeronautics industry dominant in the world and produce the best aircraft, too.

Perhaps some of you might have a few questions that you would like to ask me and I may be able to give you some thoughts on either these issues or Congressional issues generally.

QUESTIONS AND ANSWERS

QUESTION: Has any thought been given to the possibility of subsidizing fuel for airlines?

CONGRESSMAN GLICKMAN: I do not think so. With the advent of deregulation, the airlines have been given significant fare flexibility that they never had before. I would say the answer is probably no, I do not think so.

QUESTION: Congressman, you mentioned that you thought one thing that needed to be done was the cooperation between industry and government. Do you have any specifics?

CONGRESSMAN GLICKMAN: Again, I think that cooperation is one of those subjective terms. I think that we have got that to some degree in the aviation industry because of the role between the military and the aerospace companies and also partly because of the role of NASA. I think that the seeds are there in the aerospace industry. I think as a practical matter, though, there has been such an enormous regulatory tension between government and business over the last 20 or 25 years that there is just enormous distrust.

One of the things to do besides saying we are going to reduce regulations, is to try to bring business and government and the work force together, labor and cooperative councils. They have those in Japan and they have those in Western Europe to some extent.

The automobile industry is perhaps the worst example. It is almost like there is an iron curtain between the automobile companies and the government because of that regulatory tension.

Maybe what we need to do when we start deregulating some of these things is to bring the industry in and begin to talk about what type of affirmative, helpful role can government do? I just think it is attitudinal as much as anything else.

Second of all, business has to take some initiatives here. They cannot wait for government to do it. It will never happen if they wait for government to do it.

QUESTION: Have you given any thought to tax incentives for accelerated research?

CONGRESSMAN GLICKMAN: Tax incentives for accelerated research, there are several bills in the hopper to do that kind of thing for all different types. Others argue that maybe just the general depreciation relief might help in that area, too. I do not see any special status given to R&D in a tax bill unless the administration would decide that they would want to pursue that in a second tax bill because there is quite a bit of support for that.

VOICE: I agree with the NASA role very strongly but I just thought that that would help industry either in the area that you talked about, accelerated depreciation. That in itself, I think, would have a great impact.

CONGRESSMAN GLICKMAN: I think you are going to find any tax bill we pass is going to have some of what I call "reindustrialization relief," accelerated depreciation of some sort. Whether we have a special tax credit for R&D, I am not sure.

QUESTION: An extension of that, have you given any consideration to a tax incentive plan that you could apply against capital expenditures to really reduce the consumption of fuel?

CONGRESSMAN GLICKMAN: It is a good idea. As far as I am aware, no, there has been no separate serious consideration of that in the Ways and Means Committee on the theory that the fuel prices themselves coupled with general tax reductions, accelerated depreciation would do what you are saying.

VOICE: But you would really sweeten it up if you would.

CONGRESSMAN GLICKMAN: Yes, that is very true. And particularly since the administration has decided to de-emphasize direct subsidies to a variety of energy development alternatives.

Yesterday I had a meeting with David Stockman and he said we have got a lot of tax incentives. We asked him, "What is your energy policy?" Basically he said price plus a series of general tax measures.

There really is not too much in existing law. Some solar stuff and a few minor things. So they may be amenable to that kind of thing you are talking about.

QUESTION: How would it get off the dime then?

CONGRESSMAN GLICKMAN: There are about 10,000 tax ideas floating around here. There has got to be some consensus. If the industry generally believes that some sort of tax break geared towards capital costs associated with reducing fuel use would be the idea, then I think that some of the trade associations here need to put that together and get it up to the Hill.

Once we see there is some support back in the home bases or throughout the country, we might be able to work on something like that.

QUESTION: Congressman, you mentioned talking to Mr. Stockman the other day. He made a comment about NASA in the past concerning their priorities and it has always seemed to me that NASA has been very beneficial, like you say, in promoting aeronautics and aerospace and this is one of our two greatest things that bring in foreign revenue. How does the Congress perceive NASA? I means are they received in good enough light to actually perhaps get some sort of an increase in the future?

CONGRESSMAN GLICKMAN: No, not now. Two things. Number one, those of you from the Washington area have read a series of stories in either the Post or the Star that has talked about NASA and the fact that as their mission in the space program began to diminish and how the age of their engineers continued to go up and they did not attract new people because of the nature of their program and how they had problems solidifying their image. They used to be very glamorous before. The space area has tended to dominate in the last 20 years of NASA's work. That may be changing some.

I would tell you this: They are not going to get an increase this year. Our subcommittee, in fact, approved \$10 million over the Reagan budget but it still is \$15 million less than what we actually spent last year and with inflation dollars, we are about \$40 million less than last year. But there is strong interest in NASA. I think that it can be developed and it is just going to take a lot of people in the industry and a lot of members on the Hill to want to push it through. I do not sense any real negative feelings towards it at all.

When the economy is bad and when the country is not growing, you tend not to emphasize those long-term issues. You tend to look at the short term. NASA does not fit into that very easily as far as the average voter is concerned unfortunately.

QUESTION: It would appear on the surface, anyway, that the American public and the public of the world is being victimized by the world's greatest-rip off of petroleum prices. The president of Standard Oil testified a few months ago that Standard had spent approximately 20 percent of their gross profits or net profits on oil exploration and R&D, and at the same time collecting 25 percent on oil depletion allowances. Is there anything in Congress to reduce the oil depletion allowances for imported oil where exploration is not involved or is there anything in Congress to reduce the oil depletion allowance on those profits that are invested in industries other than the business of producing oil? Can it be required to spend some R&D on developing synthetic fuels such as liquid hydrogen?

CONGRESSMAN GLICKMAN: All right. The first thing is that the majors are not eligible for the oil depletion allowance. Congress has eliminated them. Independents primarily are the ones that are eligible for that. They are eligible for the foreign tax credit, however. They can take a credit on their own income taxes for taxes paid to foreign governments. Some argue that that should be ended. I think that it should be ended and I think that ultimately it probably will be ended.

Most of the integrated oil companies spend money on R&D in varying degrees. I think that you will find great questions in Congress regarding the major oil companies spending a great deal of their assets outside of the energy area. It is troublesome to see. The old classic case, Mobil buying Montgomery Ward, which by the way, they are not making any money on and they are pouring a lot of their dollars into it for all practical purposes. Even more serious is the question what are the oil companies doing with their money now? They are putting it into Saint Joe Minerals, Kenicott Copper, Anaconda. It is a smart move because the minerals of today will be the OPEC of 20 years from now. What I am saying is that mineral shortages will be serious 20 years from now, in my judgment, like oil is today.

I think that is very bad public policy. I have no problem with the oil companies going into any form of energy area, coal, nuclear, hydroelectrics, solar, you name it. That is their function. They are an energy company and they should not be prohibited but it is troublesome as a matter of national policy to see them benefit by OPEC oil increases and put their money into non-energy areas. Some do a better job than others, however, so I cannot cast a giant blanket on that.

One thing I think you should be concerned about is the fact, and this is part of the deregulatory spirit, the Department of Energy's enforcement budget and the Antitrust Department of the Justice Department's enforcement budget are being reduced to some degree in this Administration. That may not be part of a very good public policy.

QUESTION: Yes, Congressman, with regard to recent developments of R&D by NASA, it is great with regard to the lab and with regard to what is available that can be done in aircraft. You mentioned the light aircraft industry being depressed. As a result of NASA's involvements in composites and also improved air flow design, a small aircraft can be built that is twice as efficient today but it is not going to be built as a result of the economic burden of certification. The same thing approaches the larger aircraft, also. Unless something is certified, it is not going to be exported. What is going to be done with regard to aiding the certification process so that the benefit of, first off, the export and also the reduced oil demand will be met in our nation?

CONGRESSMAN GLICKMAN: A couple of things. One, the subcommittee is concerned about the role of NASA's work in general aviation generally and we are going to try to enhance that to some degree.

On the certification process, I cannot give you an answer except the new head of the FAA is Lynn Helms who was president of Piper Aircraft Corporation. He has spent his whole life involved in some degree or other with aviation. That is unusual. We have not had very many FAA administrators who have been as involved in aviation as Mr. Helms. Hopefully he has some sympathy and some sensitivity to certification problems. I think that is probably the best thing that we can do and I think that Mr. Helms just needs to be reminded of the problem.

Are you with one of the smaller companies?

VOICE: I am with a consulting firm. The problem is not so much, again, that the certification process is wrong or something excessive. The certification process is quite correct in getting let us say an acceptable material for a particular aircraft, an acceptable engine or an acceptable aircraft modification.

The fact is that the companies work on basic profit. Even though it may be quite energy inefficient with regard to let us say manufacturing the Cessna 152 or a particular engine on a large transport, the fact is that it is very cost effective.

You mentioned about maintaining the leading edge of aerospace technology. We have got the R&D. NASA's side is well up to speed but it is overall second with regard to getting it out to the customer to purchase it. Right now nothing is being done with regard to helping in that sector. I am not looking to the FAA to say, all right, anything goes with regard to putting something on an airplane. What I am saying is you talk about the situation in Japan, you talk about the situation in some of these other nations with regard to the government helping industry. Here is a sector where, all right, expedite the process, aid the process, subsidize the process, recoup it somewhere later but it is not going to be done when the funds are right.

CONGRESSMAN GLICKMAN: All right, good point. Let me take one more question and then I am going to have to leave.

QUESTION: Do you think NASA's aeronautics program would be beneficial if the operational part of space activities were separated, as has been recommended by some people?

CONGRESSMAN GLICKMAN: And sent where? To the Defense Department?

VOICE: No, you could set it up in a company like Comsat.

CONGRESSMAN GLICKMAN: I do not think so. I mean I am not familiar enough with the issue, to be honest with you. Tony Taylor is my staff assistant here. I will talk to him about that a little later. I don't think so. I have been on the subcommittee now for 4 1/2 years and I have really never heard from any users, any companies, any of the NASA staff that that is really a potentially serious problem.

I do think, however, that one of the most serious problems NASA has is defining its role as the space shuttle begins to take on a more defense oriented purpose and will the Defense Department ultimately take over that function of NASA's work? That, I think, is a policy issue that is going to face us in the next ten years.

I am going to have to go but I do appreciate speaking before you today. My assistant, who is staff director of the subcommittee, Tony Taylor, is in the front row and he would be the one to talk to if you have any questions. If the subcommittee can be of any help to you, he would be the one that you ought to write to. The Committee on Science and Technology.

Again, I applaud this kind of effort and look forward to hearing from you and working with you in the future. Thank you very much.

Panel Discussion:
**“Where Do We Go
From Here?”**



PRECEDING PAGE BLANK-NOT FILMED

PANEL PRESENTATION

Richard T. Alpaugh
Chief, Systems Efficiency Branch
Department of Energy

At the risk of repeating some things that may have been mentioned yesterday, I would like to very quickly review what the petroleum use situation is now with regard to aviation. This is a slight variation of what Charlie Hoch had shown yesterday, indicating the 1980 use of petroleum in transportation.

Chart 1

PETROLEUM USE IN TRANSPORTATION
1980

			SHARE %
<u>HIGHWAY</u>	7,227,720 BOPD		
AUTO	4,345,080	--	50
TRUCK	2,834,400	--	33
OTHER	47,240	--	--
<u>NONHIGHWAY</u>	1,464,440 BOPD		
AIR	897,560	--	10
RAIL	236,200	--	3
MARINE	330,680	--	4
<u>TOTAL PETROLEUM</u>	8,692,160 BOPD		100

Transportation, you may recall, consumes a little over one half of the petroleum used in the country. Reviewing Chart 1, it is obvious that the highway modes are the predominant users of petroleum but that air is also a significant non-highway user, as a matter of fact, with most consumption estimates being in the range of about 8 to 10 percent of transportation petroleum.

Chart 2

PAST ANNUAL GROWTH
AVIATION GROWTH IN REVENUE PASS MILES

1947-1958	-	12.7%
1958-1965	-	10.7%
1965-1970	-	13.7%
1970-1978	-	7.3%

AUTO GROWTH VEHICLE MILES TRAVELED

1950-1975	-	4.3%
-----------	---	------

BUS GROWTH ENERGY CONSUMPTION

1950-1975	-	0.7%
-----------	---	------

FREIGHT GROWTH -- TOTAL TON-MILES

1950-1975	-	2.8%
-----------	---	------

SOURCE: ANL/CNSV-4 -- Projection of Direct Energy Consumption
By Mode -- August 1979

What I would like to show on this chart is the growth that has been experienced in the aviation field, which I am sure most of you are aware of, and compare it with the growth that has been experienced in other segments of transportation.

The aviation growth, while slowing down in recent years, is still considerably higher than has been experienced in the auto and far more than the bus. The bus has had essentially no growth over the last 25 years. Freight growth has been quite nominal in comparison with the aviation growth. So aviation has obviously been a strong growth industry over the past quarter century.

Chart 3

PROJECTED ANNUAL GROWTH IN ENERGY USE
1975-2000

	<u>RANGE</u>	
AUTO	--	1.3% to 1.4%
BUS	--	0.9% to 3.8%
AIR CARRIER (total domestic & international)	--	2.7% to 6.9%
TRUCK	--	2.2% to 4.1%
RAIL	--	0% to 6.6%
ALL TRANSPORTATION	--	0.3% to 2.0%

* FAA AVIATION FORECASTS FY 1981-1982 PREDICT 4.8% ANNUAL GROWTH IN REV. PASS. MILES FROM 1980 to 1992

Looking into what is likely to be experienced in the coming years, this next chart has extracted data from an Argonne National Laboratory report which states ranges for various transportation system projected growths. The ranges represent various predictions that have been made by different parties.

Again, if you examine this data, despite the lower growth predicted to occur in the air segment in comparison with past years, the growth is still somewhat higher than for any other segment of transportation. You will note the 2.7 to 6.9 percent growth/for aviation as compared with all transportation, which is predicted to grow at no more than 2 percent. Most predictions show aviation continuing to grow faster than other segments and perhaps continuing to represent more of a problem in terms of providing the necessary energy for their growth.

You may also note the FAA forecast which shows a 4.8 percent annual growth for aviation.

Chart 4

IF A 4% ANNUAL GROWTH IN AVIATION ACTIVITY AND ENERGY USE IS EXPERIENCED:

- o PETROLEUM USE WOULD INCREASE FROM APPROXIMATELY 890,000 BOPD IN 1980 TO 1,900,000 BOPD IN 2000
- o AVIATION SHARE OF TRANSPORTATION PETROLEUM USE COULD GROW FROM 10% TO 15-18% BY 2000

Now, if we were to run through the simple mathematics of what would occur with a 4 percent annual growth in aviation, which is perhaps a little bit less than most of the industry seems to be predicting, it can be shown that the current energy use of about 900,000 barrels of oil per day would grow to nearly 2 billion per day by the year 2000.

If you consider that aviation, even at 4 percent, would be growing more rapidly than the rest of transportation, aviation's share would grow from about 10 percent to roughly 15 to 18 percent. Again, illustrating a potential problem in terms of fuel availability.

Figure 1 simply shows the growth that has occurred in fuel prices, as I am sure you are all aware of, showing from 1973 to the current date we have grown nearly tenfold in terms of energy prices

With the results shown in Figure 2, which by the way, is from a Boeing report, direct operating costs attributed to fuel costs during the same period have grown from 28 percent to 52 percent.

Air Carrier Fuel Prices (annual average)

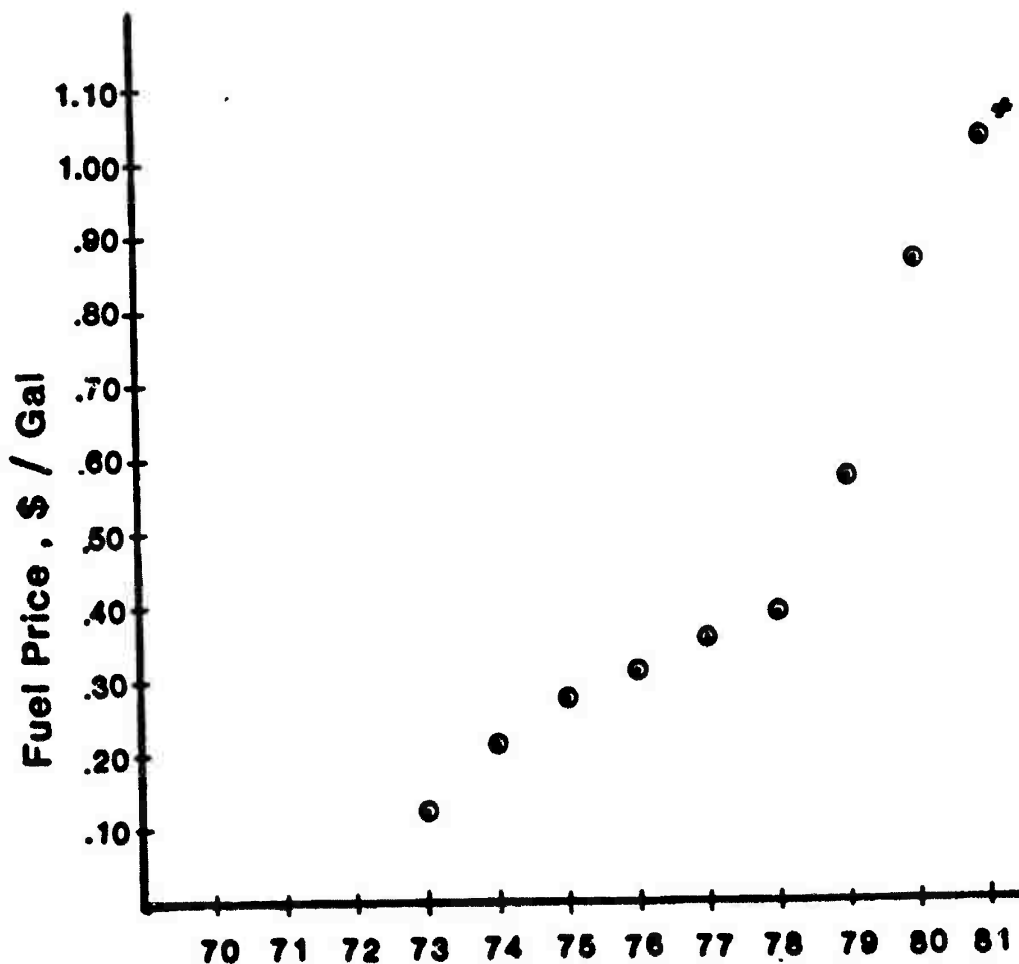

SOURCE: C. A. B.
♣ March estimate

Year
FIGURE 1

Fuel Cost Effects on Operating Cost

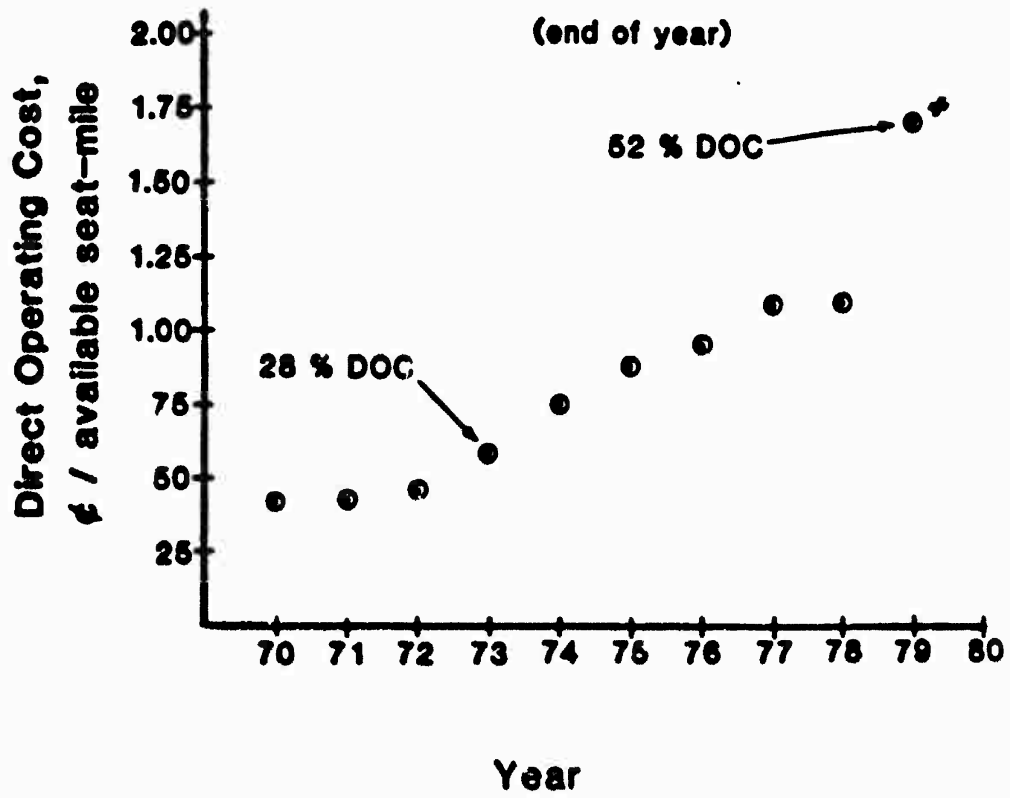

Year

FIGURE 2

SOURCE: Boeing Commercial Airplane Company

◆ mid-year estimate

What will happen in the future, of course, is anyone's guess. The projections of how fuel costs will elevate have been notably inaccurate in the past and I am not going to hazard a guess as to what may happen in the future.

What does this all mean? If indeed the various projections are substantially correct and commercial aviation continues as a growth industry, what can or should be done to alleviate the impact of the increases in fuel costs and increased demands on the part of the aviation industry on available fuels?

If any quick or easy solutions exist, I am unaware of them. What the industry appears to face is a long step-by-step effort in which evolutionary changes may be effected. Generally speaking these efforts will be basically aimed at: 1) reducing energy consumption by obtaining improved efficiencies of fuel use or increased productivity per unit of energy consumed and 2) providing alternative energy sources which while not necessarily reducing energy consumption, will broaden the applicability of available fuels for aviation.

All I can foresee is a continuing program, supporting advanced technology, developments by industry, NASA, and DOD on propulsion, aerodynamics and structures, evolving designs affording efficiency improvements. Continuing and perhaps accelerated attention should be paid to fuels investigations leading to verification of propulsion system operation on broad spec jet fuels, synthetic fuels and perhaps in the long-term, other more esoteric alternatives.

Last but not least, the airlines themselves must continue to direct their attention at identifying and implementing improved operational and maintenance procedures as economic conditions dictate their cost effectiveness.

PANEL PRESENTATION

**Charles J. Hoch
Chief, Energy Division
Office of Environment and Energy
Federal Aviation Administration**

PRECEDING PAGE BLANK-NOT FILMED

Yesterday, I presented an overview of the recently issued DOT/FAA Aviation Energy Conservation Policy. Today, we are asked to chart a course from this point forward.

With regard to the FAA, I guess what we are really asking is, "How do we ensure that our energy policy will succeed?"

In my view, the FAA must concentrate on four management areas to ensure the success of its energy conservation objectives.

First, policy implementation must be vigorous and timely. I know we have captured the proper spirit to ensure this prerequisite. For example, the DOT/FAA energy policy commits us to the development of an analytical energy model which can be used to assess the impact of changes to the air traffic procedural environment. We originally estimated that the modeling effort would be available in the summer of 1981. This is the date we committed ourselves to in the policy document.

Well, I am happy to say that we have already applied the model in a study of the Northeast Corridor. It was able to identify a potential annual savings of 3 million gallons of aviation fuel through the implementation of revised or new air traffic procedures. And, this is in only one geographical application!

So the spirit of vigorous implementation as exhibited here is being exercised for the entire policy and our office is dedicated to the assurance that that takes place in a uniform manner.

The second area of management attention that we have to undertake is better coordination. Better coordination not only among agencies that are concerned with energy efficiency, but among the user groups as well.

Let me address the coordination among agencies. When we started out two years ago, we were still called the Office of Environmental Quality. We were given the responsibility of energy and the name of the office changed. We started from scratch. At that point, without casting aspersions on any agency, when a regulatory action took place in the Department of Energy that had potential ramifications in the aviation industry, we literally read about it first in the Federal Register. Today that situation has changed substantially. We coordinate well with the people that you see here on this panel and at this conference. We are given sufficient warning of potential actions that impact aviation so that we can assist in providing input towards those actions. I look forward to an even more improved situation in this regard in the future.

Before I go into the third area, let me go back to something that Congressman Glickman discussed. That is the ACEE program that NASA is involved with. I also mentioned yesterday that we are involved in a task force with the Department of Energy and with NASA in an overview of all programs which have a potential impact on aviation efficiency. We are involved in that program and we expect it to be an ongoing effort. The objectives, again, are to eliminate any wasteful overlap of those programs, as well as to remove impediments to the application of products coming out of our mutual efforts.

Third, we must institute a process of policy impact assessments to be able to gauge the effectiveness of actions we have taken. This is particularly necessary in the area of air traffic control program actions. How many gallons has FAD (fuel advisory departure procedures) saved in Chicago? Are those energy savings applicable to Denver or other terminal areas? We have to know. Accordingly, monitoring the impact of program actions on energy conservation is one of our policy commitments. Without this capability we will not be able to judge whether our efforts are as successful as anticipated or whether our resources might not be better concentrated in other areas.

This also harkens back to a criticism that our agency received, I believe back in 1977 from the General Accounting Office in which they took us to task for not having in place an appropriate monitoring system for fuel saving programs. We are doing things but we did not know how much they were saving. I think that that is an appropriate criticism and that is why it is included as one of our 31 policy elements within our total policy.

The fourth management action is a simple extension of the third. Having determined the effectiveness of specific program actions we must continuously refine our total policy position and develop alternative or revised policy actions as needed. No policy is written in granite. It changes. It has got to be dynamic to address the changing times and the circumstances we find ourselves in. As we go down the road from this point forward we anticipate revising the policy at appropriate points.

It is with this total approach, using these four management tools that I think we can achieve the objective of energy conservation in the future.

Thank you.

PANEL PRESENTATION

**Roger Winblade
Manager, Transport Aircraft Systems Technology Office
National Aeronautics and Space Administration**

Within the transport aircraft technology program in NASA, there are eight individual elements that in total make up a fairly comprehensive approach to future energy efficient transport airplanes. Although several of them have been mentioned already, I would like to go through them individually and spend a couple of seconds describing what they are.

First a comment in response to an earlier question raised concerning Government assistance in that area between technology being ready and technology being applied, (such as providing data for certification). One very good example is in the composites area.

Through the NASA secondary composite structures program, starting with spoilers on 737's, progressing to the upper aft rudders on DC-10's. We have amassed something approaching 180,000 flight hours in airline service with high time element over 18,000 hours purely as a means of establishing a data base that can support certification. However, this is in no way attempting to change the requirements.

The Aircraft Energy Efficiency program, called "ACEE," was in response to a Congressional request in 1975 after the full recognition of the impact on fuel prices of the oil embargo in 1973. The request was fairly specific, to identify and implement an aggressive research and technology development acceleration program. A program to accelerate both the development and application of energy efficiency technology for transport aircraft.

What resulted from that was a combination of six individual technology areas that had high potential both in the near term and in some areas in the long-term for significant savings in fuel.

The first and nearest term, the Engine Component Improvement program, was an attempt to go into existing production engines, the JT-8D, JT-9 and the CF-6, identify specific components that could be essentially re-engined for greater efficiency, do that and put them back into serial production. That has happened, the program is complete, several of the components are in production and generating the kind of savings that Congressman Glickman alluded to.

A second part, that I mentioned in the earlier session, was the diagnostics portion. The gathering of massive amounts of data to identify the source and the real cause of the performance degradation during the service life of the engines. And from that infer or identify either improved maintenance procedures or different operating procedures for reducing that degradation.

Also, the output of that would lead into another major element that was included in the program, the Energy Efficient Engine. A contract effort with the two principal engine manufacturers in the United States to apply the maximum amount of new technology to a transport class engine with the principal emphasis on energy efficiency. Carrying the program through fabrication and ground tests of not an engine, per se, but all of the pieces running together to be able to evaluate the interactions. Included in the objectives were the results of the performance degradation. Do the kind of things that are necessary to reduce that service life decline.

The third program and I will admit at the outset not with total support from the industry, was based on the perception that propellers are, in fact, a pretty efficient way to move airplanes. We undertook a research program to develop propellers that would maintain sufficiently high aerodynamic efficiency at .8 Mach number, roughly transport kinds of speeds and altitudes to make them competitive with the then 1975 turbo fan engines.

The potential still appears to be there. We have demonstrated 80 percent efficiency at .8 Mach number, and are starting into the second phase now, addressing the structural dynamics. The propellers, I am sure most of you have seen pictures of them, are multi-bladed, highly swept, very exotic looking propellers. There are still some key technical problems to be resolved. Structural dynamics, what the propellers do to the cabin environment in terms of acoustics, noise, and cabin comfort.

The fourth element, Energy Efficient Transport, is the part of the ACEE program dedicated to aerodynamics, active controls, and configurations. What the shape of the airplane could or should be to be most energy efficient.

Our conclusion I am sure is the same as everyone else's, that airplanes are not going to change shape very much. If you go through the maximum application of active control systems, the exotic electronics, the net result is the airplane is indiscernible from a current configuration. They are small changes that have had fairly significant effects on aerodynamic performance but they look pretty much the same. The air foils are a little different, the CG is maybe in a little different location, the controls may be a little larger, a little smaller or move a little faster. The net result can be 8 to 10, even as high as 12 percent increase in cruise efficiency from playing those kind of games.

One of the major single payoff areas is building airplanes from something other than aluminum. Graphite composites hold very high promise for reducing the basic structural weight of airplanes. We have successfully demonstrated weight reductions of 25 to 30 percent on secondary and on medium primary structure, as we have identified it,

such as vertical fins, or horizontal stabilizers. Individually the weight savings are there. However, the weight of those components compared to the total airplane weight is small. So the net savings to the airplane such as the 767 is half to three quarters of a percent. It is small. Yet the next step, which we are attempting to get under way right now is to move into the primary structure, the large pieces. There we can fairly legitimately project fuel savings because of the net reduction in weight of 10 to 15 percent, just by changing the materials.

One of the very long-range programs, Laminar Flow Control, the ability to maintain the smooth, non-turbulent or laminar boundary layer around an airplane. It is a theory that is well accepted. It has been demonstrated both in the wind tunnel and in flight. It is possible to achieve.

If you maintain laminar flow over the lifting surfaces of an airplane, you can anticipate anywhere from 20 to 40 percent reduction in cruise fuel use over long ranges. The problems, however, are it does not work if you fly into ice crystals. Bugs tear it up. The normal wear and tear on the surface that is full of small holes may or may not be acceptable. Our program is really addressing that class of problems. The reliability, the manufacture ability, maintainability of systems that can provide laminar flow.

In the area of air traffic control, the subject has come up a number of times. Approximately five years ago we established a facility. The TCV, or Terminal Configured Vehicle, is a Boeing 737 modified so that there is a second cockpit, a very exotic full cockpit in the aft cabin. It provides us the opportunity to explore the integration, the interactions, and the requirements for new devices, new concepts, and new procedures in the air traffic control environment.

An example of the things that the TCV program has accomplished was a program carried out in the Denver area with the ATC arrival control procedures. We were able to demonstrate arrival at a specified fix within plus or minus two seconds of the specified time and that is from the cruise condition, at the same time following nearly an optimum energy path. The vehicle capability can be there if we work it the right way.

The final area is Aviation Safety. While it happens to fall under transport programs in NASA it addresses all facets of aviation but its major focus is toward the large airplanes.

One of the trends I think you will see out of NASA will be an attempt to make safety and safety related items more cost effective. I will give you an example.

If the seat structure in a transport airplane were built from composite materials, it may well be possible to reduce 5, 10 to 15 pounds from each seat. If you multiply that by 200, 300, 400, the net weight savings for a seat that could be considerably higher in its

tolerance to loads could be very significant, making essentially safety pay for itself in that way.

Those are the programs that we have under way. There should be a recognition that in the research environment these programs started in 1976. They will be concluded sometime in 1987. A characteristic is that from the demonstration of technology until its incorporation will be anywhere from 7 to 10 and maybe as long as 15 years. So the idea of near-term focus versus long-range has to be taken into consideration when you talk about R&D. And with that I will end. Thank you.

PANEL PRESENTATION

Gordon A. McKinzie
United Airlines

PRECEDING PAGE BLANK-NOT FILMED

I will make my remarks very brief. You have heard from a great many airline folks during this conference. Just about half of the presenters were from the airlines. I certainly cannot speak for the consensus of airlines regarding market strategies and the way we go after revenues in various markets, but I think I can give you an idea of what I have heard from my dialogues with my counterparts in other airlines. It might be the last time you hear this because it is getting harder and harder for us to talk to each other in this growing area of antitrust sensitivity where proprietary-type information is involved. In the future you may hear from us only in our response to proposed rulemaking.

The things that we have come up with as consensus items fall mainly into categories of new technology and flight planning. Very briefly, when we talk about new technology we all must admit, with very few exceptions, that none of our aircraft today are flying at the design points for which we bought them years ago.

Today's fleet mix of airplanes belong to another time. Even if you are talking about the 747, which we bought to race Pan Am to Honolulu at .88 Mach number, that sort of thing is absolutely ludicrous today. A pilot has never seen .88 Mach number currently flying 747's unless Captain Craven might admit it gets away from him in cruise sometime. Otherwise, it is just a thing of the past.

Engine sizing is not right. Inlet airflow is designed for airplanes flying those speeds which today are also no longer applicable. There are things that happen with the work transferred in and out of the engine in today's lower speed regimes which are not optimum for the aircraft. And while you are talking about engines, you might also admit to yourself that the wings are not put on right. If you have ever seen a DC-10 flying at long-range cruise and have tried to push one of those liquor carts up the aisle, you will know what it means to be a little bit high on angle of attack when the wing incidence is not correct for the speed. So we really are flying design points that belong to an era where fuel was not quite the swinger that is today.

We also want to talk about flight management computers. There has been a lot of discussion in our industry about what these things can do. We are convinced that just the mere function of flight path smoothing is a real advantage by taking a lot of fine tuning out of a pilot's responsibility and by letting him manage his airplane in its own airspace without a lot of continual monitoring.

In this same breath I want to say that the algorithms that are being presented to these flight management computers are no better, normally, than the ones that we provide out of our own flight planning system, and they have to be better. In that regard, we are looking forward to developing better algorithms and better models, whether we do them ourselves, or with assistance from NASA, from the FAA, or from

others who have been able to put together some expertise in the profile modeling area.

Also, again in the same breath, I see a few Captain-types in the audience cringing a little bit when we talk about flight management computers. We do not want to see the proliferation of electronics in the cockpit that is going to take the airplane away from the pilot. You must admit that while these things are all well and good, if you can determine for yourself that there is marginal return coming out of something so complex that there will no longer be any cockpit compliance to using it, then you have lost the ball game.

I like to see plastic computers. I like to see wheels developed on the back on paper bags that pilots can use and play with. I like to see rules of thumb, if we can prove they are working. But I also like to see sophisticated computers if the return on the investment for that thing is good and if the maintainability is high and the pilots are enthusiastic about it. They must use it like they use INS or any of these things that they feel they really need and can rely on.

I would like to throw the little caveat out that, although we want to go as far down the technology road as possible, there is really nothing money cannot buy when it comes to an avionics firm saying it can do anything you want to make the airplane as efficient as possible. They will model the airplane so that it will feel like an airplane, but you may not be really flying it. It will be a great big giant black box humming with 50 cent transistors, any one of which can go at anytime, and that is not what we are looking forward to. But let us not discourage the development of those systems if they are showing good return.

A final note I wanted to mention about our flight planning system. We still want the freedom to move in the airspace the way we think we should. This includes descent, of course. If we really admit it, there is no airline around that says he cannot come up with the very best possible way to fly that airplane from A to B in the airspace that is given him. He needs assistance along the way. He cannot be shut out from his request for the best possible profile.

Any airline will tell you that their specification for the ultimate flight planning system would be a device that has the computer actually fly the trip from A to B in all possible combinations of wind track, altitude and speed for best fuel efficiency. That is something that none of us enjoy today. This, of course, goes hand-in-hand with getting the best kind of weather immediately from the weather service that is applicable to practically the departure time that you are leaving. Then, test all the possible options of your trip for minimum fuel within a controlled time environment. Do not let time go completely out of whack because we still have a responsibility to our passengers, and we are still a service-oriented operation. So, keep

time under control, fly that trip from A to B in the very best fuel economical way possible, and make sure that everything you have going for you inside the airplane is reliable, repeatable, and going to show good ROI at the bottom line.

That is about all I have, thank you.

COMMUTER AIRLINE OVERVIEW

J. DAWSON RANSOME
CHAIRMAN AND PRESIDENT
RANSOME AIRLINES

Thank you for the opportunity to give this overview.

Today, I would like to give an overview of our industry's explosive growth, its impact on our ATC system, and a few things we at Ransome are doing to help solve our rapidly growing ATC and airspace problems.

The combination of airline deregulation, the uncertain availability and price of automotive fuels, and, importantly surging public demand for air travel have spurred the growth of the Commuter Airline Industry beyond our wildest dreams of just a few years ago. As a result, we are gearing up to implement better service, with greater frequency to more airports than ever before. In fact, by year-end, we forecast that U.S. commuter airlines will have carried more than 15.5 million passengers, up 11.3 percent over 1979, and 500 million pounds of cargo to approximately 850 domestic destinations. In so doing, commuter airlines will have reliably performed approximately 2.7 million revenue flights, logged 2.1 million flight hours and accounted for nearly one-third of all U.S. scheduled airline service.

The twelve Allegheny Commuters transported approximately 2.5 million passengers in 1980; operated 85 aircraft; served 55 communities with over 600 daily flights, which represented 20% of total commuter passengers in the U.S. Ransome is very proud of its association with USAir, formerly Allegheny Airlines. The relation has been good for both parties, as well as the communities served.

Ransome Airlines, an Allegheny Commuter, serves twelve cities with almost 200 flights per day in the Washington to Boston Corridor. To date, we have transported almost 4 million passengers since beginning business in March of 1967. During 1967, we transported just 6,318 passengers. We expect to carry over one million in 1981. That represents an average rate of increase in passenger service of about 60 percent each year we have been in business. I might note, it has not been too many years since some local service carriers were transporting one million passengers per year.

Since enactment, deregulation has resulted in the local and trunk carriers reducing or eliminating service to about 130 cities. Surprisingly, these service reductions have included not only small, but also medium-sized communities, such as Hartford, Providence, Trenton, and New London. The high cost of operation, inadequate return on investment, and low yields inherent in operating the modern jet airplane at lower altitudes on short hauls, are forcing the major airlines to carefully scrutinize asset allocation--that is, in what markets they can profitably use their aircraft. The simple fact is, operating the jet airlines on stage lengths of under 200-300 miles has simply become financially unsound not only from the standpoint of cost of operation, but also asset allocation.

Where is this leading? It's leading to a greater dependency by the small and medium communities on the major hub airports for access into the mainstream of the nation's air transportation system. Then where does it lead us? It leads us into greater competition for presently available enroute and approach airspace, gate space, terminal space, and other airport facilities. In fact, it is estimated that, unless something is done,

and done soon, the direct cost of air traffic delays to our industry could reach an estimated \$1.5 billion by the mid-1980's. This figure does not take into account the tens of billions of dollars lost by our customers in terms of time, productivity, missed connections, and out-of-pocket expenses. I am sure you will agree, this is a waste of our resources we simply cannot afford! One solution is the greater use of currently available reliever airports (Long Island/MacArthur; Mercer County/Trenton; North Philadelphia; Wilmington, Delaware, etc.), but they will take time to develop. However, they are assets we must begin protecting now for the future.

In the meantime, we at Ransome Airlines are embarking on the most ambitious program in our history. It involves investment by our airline of some \$40 million for new high technology aircraft and flight control systems. It is an effort on our part to find a solution to this ever-growing and serious problem of air traffic delay and airport access.

Just over a year ago, Ransome Airlines introduced into service the first of a number of deHavilland DASH-7, four-engine, quiet, short take-off and landing, 50-passenger aircraft into the Philadelphia/Washington market. This remarkable aircraft has the ability to land with comfort and safety within 1,000 feet or less - maneuver at 100 knots with a full gross load - and turn in a radius of only 2,000 feet. Coupled with all of this performance, the aircraft will be equipped with a three-dimensional AREA-NAV system capable of storing 200 non-volatile way points integrated into the automated flight control system. Ransome has secured an agreement with the F.A.A. to utilize special AREA-NAV route and microwave approaches for service between Philadelphia and Washington, D.C. These routes and approaches are removed from the conventional route and approach systems and are, therefore, termed "non-interfering." The DASH-7 aircraft will be equipped with airborne computer-generated pictorial route display on the aircraft's radar that can be used concurrently with the weather avoidance function of the radar display. These functions will drive the auto pilot producing an automated flight path from take-off to landing. Yet, you might logically ask -- "What will this do to improve airport access?"....

For the commuter air carriers, there is reduced fuel consumption - 40 miles less travel through the enroute airspace on each PHL-DCA leg.

For the air traffic controller, there is less need for communication and, therefore, the benefit of a reduced workload.

For the flight crew, there is substantially reduced workload. The automated system requires a minimum of pilot input. The crew, therefore, is free to manage the aircraft systems and monitor the flight's progress through the congested airspace. Also, the visual flight path display on the radar screen provides valuable backup information to the crew for greater confidence.

And, of special interest for the airport operator, the DASH-7 is a good neighbor, since it is the quietest airliner ever built.

The routes between Washington and Philadelphia are generally outside the conventional enroute and approach paths used by other airlines. Our aircraft will land on the so-called "non-precision" runways at National and

Philadelphia (33 and 21 at National and 17 at Philadelphia). Thus, our flights will be removed from the so-called "daisy chain," reducing up to 40 miles of travel through airspace and, as an added benefit, opening up additional capacity for the higher performance jet aircraft on the conventional I.L.S. system. Further, by increasing the airport's capacity, this program will reduce fuel waste, time delay, and loss of human productivity.

The accuracy of the AREA-NAV system enroute is measured in terms of hundreds of feet, not miles. One objective for our crews will be to fly a consistent pattern day-in and day-out in terms of speed, vertical and horizontal flight path in order to develop the confidence of the air traffic controller to the point that his function becomes one of monitoring the flight profile. Thus, this program should reduce ATC workload and moderate the need for extensive voice communications.

All the nation's airports are experiencing a greater number of commuter airline operations. We hope this program of ours will contribute to the solution of our airport capacity problems, reduce fuel consumption, and encourage other airline operators and airports to develop similar programs. We also hope to encourage airport management and the F.A.A. to build MLS-equipped short S.T.O.L., or reliever, runways at their airports and consider the use of existing taxiways and stub runways for this purpose. As an example of this, at Philadelphia International, Ransome Airlines has agreement with airport management and F.A.A. air traffic control personnel to make use of the existing taxiway "A" for departure.

Ransome Airlines will start its M.L.S. evaluation program, working with the R & D arm of the F.A.A. We will be operating six prototype airborne receivers installed in our DASH-7 fleet. Two ground units are now operational at Philadelphia International and Washington National. At National, they will service runways 33 and 21, and at Philadelphia, runway 27.

I am very happy to have this opportunity to participate in this Symposium on Commercial Aviation Energy Conservation Strategies. I hope you will find our 3-D, R-NAV and MLS program interesting and constructive.

PANEL PRESENTATION

**Richard L. Altman
Manager, Washington Operations
Commercial Products
Pratt & Whitney Aircraft Group
United Technologies Corporation**

During its two-day session this symposium has reviewed in detail conservation gains to be obtained largely in current fleet operations and maintenance. I am sure that most of you are working closely with the manufacturers product support departments in attempting to optimize the fuel efficiency of the current fleet. My presentation, and indeed the theme of this panel session, follows an entirely different approach - where do we, industry and government, go from here in the pursuit of air transportation energy conservation.

The question, from the engine makers' viewpoint deserves a three-part answer (Figure 1):

- o In the near-term (1-3 years) maximized fuel savings can be obtained from upgrades to the existing fleet.
- o In the intermediate-term (over 3 years) savings will accrue from commitments to new products in the 150-passenger and larger equipment class, powered by a new generation of high bypass ratio engines.
- o In the far-term (1990 and beyond) the opportunity for new technologies - most notably the prop-fan, exist.

On net, fuel consumption (TSFC) 60% lower than the first generation turbojets can be available by the decade's end.

TECHNOLOGY REDUCES FUEL CONSUMPTION

FIGURE 1

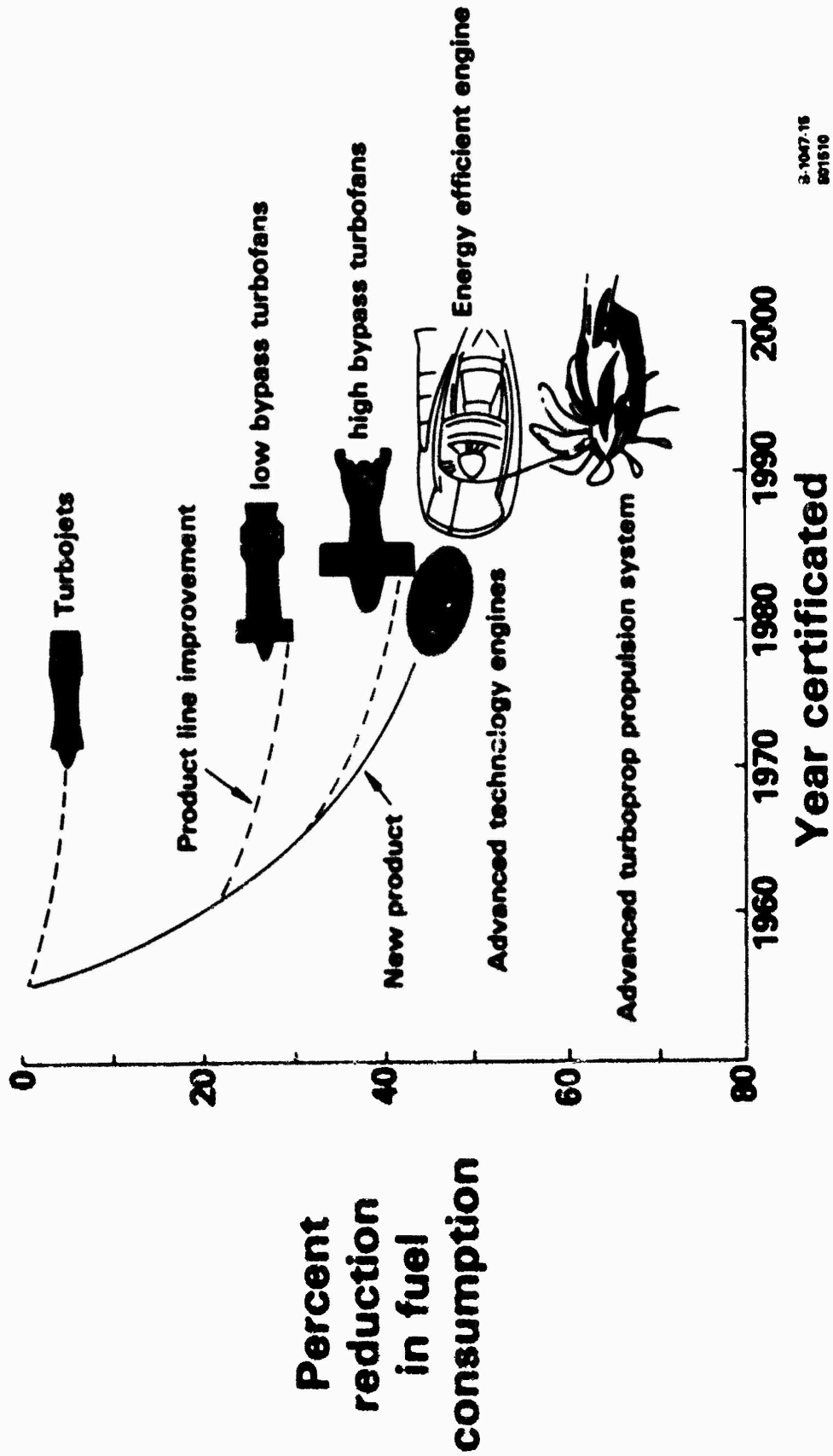

I would like to briefly address, within this framework, the commitment Pratt & Whitney Aircraft is making to energy savings in our future products and to share with you our perception of the constructive role government now plays and must continue to plan if we are to maintain a predominant "Made in USA" stamp on aircraft engine products.

Any approach to fuel conservation in the near-term must, of necessity, focus on upgrades to new and in-use P&WA JT8D engines (Figure 2). With deliveries beginning in 1982, Pratt & Whitney Aircraft's JT8D improvement package affords a 5.5% decrease in fuel use for the -15 and -17 models, and a 3.4% decrease in -9 models. Coupling high efficiency with superior durability, the package focuses on improvements in component aerodynamics, gaspath sealing, and airfoil cooling. As of early this year, firm commitments for over 600 upgrade kits have been received.

Another attractive near-term option may be the opportunity to re-engine aging wide-body aircraft with the latest in high bypass ratio engine technology as part of the Air Force Civil Reserve Aircraft Fleet enhancement program (Figure 3). Pratt & Whitney Aircraft's assessment of CRAF enhancement economics suggests that up to 3,000 gallons of fuel can be saved per mission when a 747-100 aircraft is re-engined with P&WA's newly certified JT9D-7R4 engine. With new engines more than compensating for increased aircraft weight, CRAF re-engining provides a needed inducement to airlines for their participation in the Air Force enhancement program.

JT8D COMPONENT CHANGES SAVE FUEL

FIGURE 2

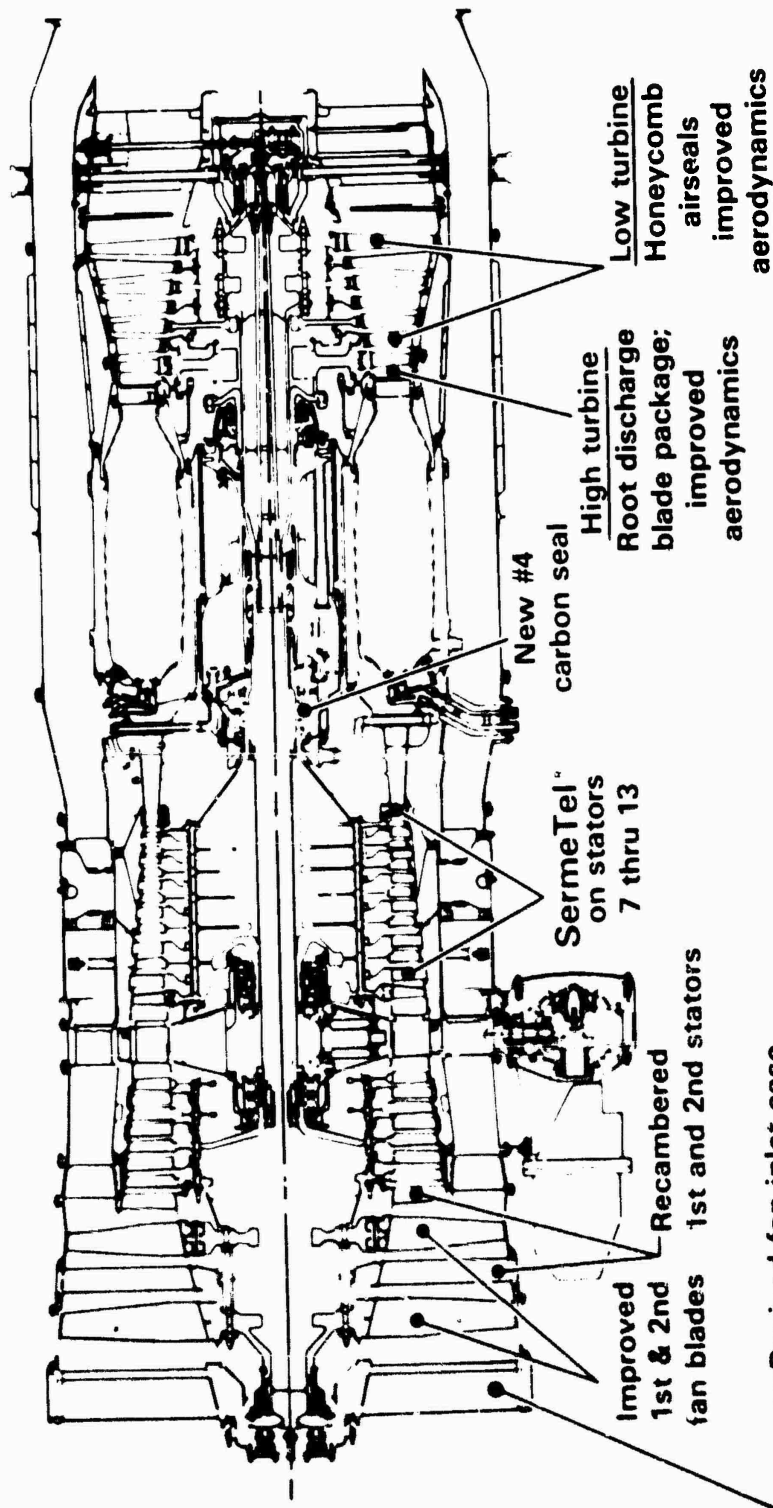
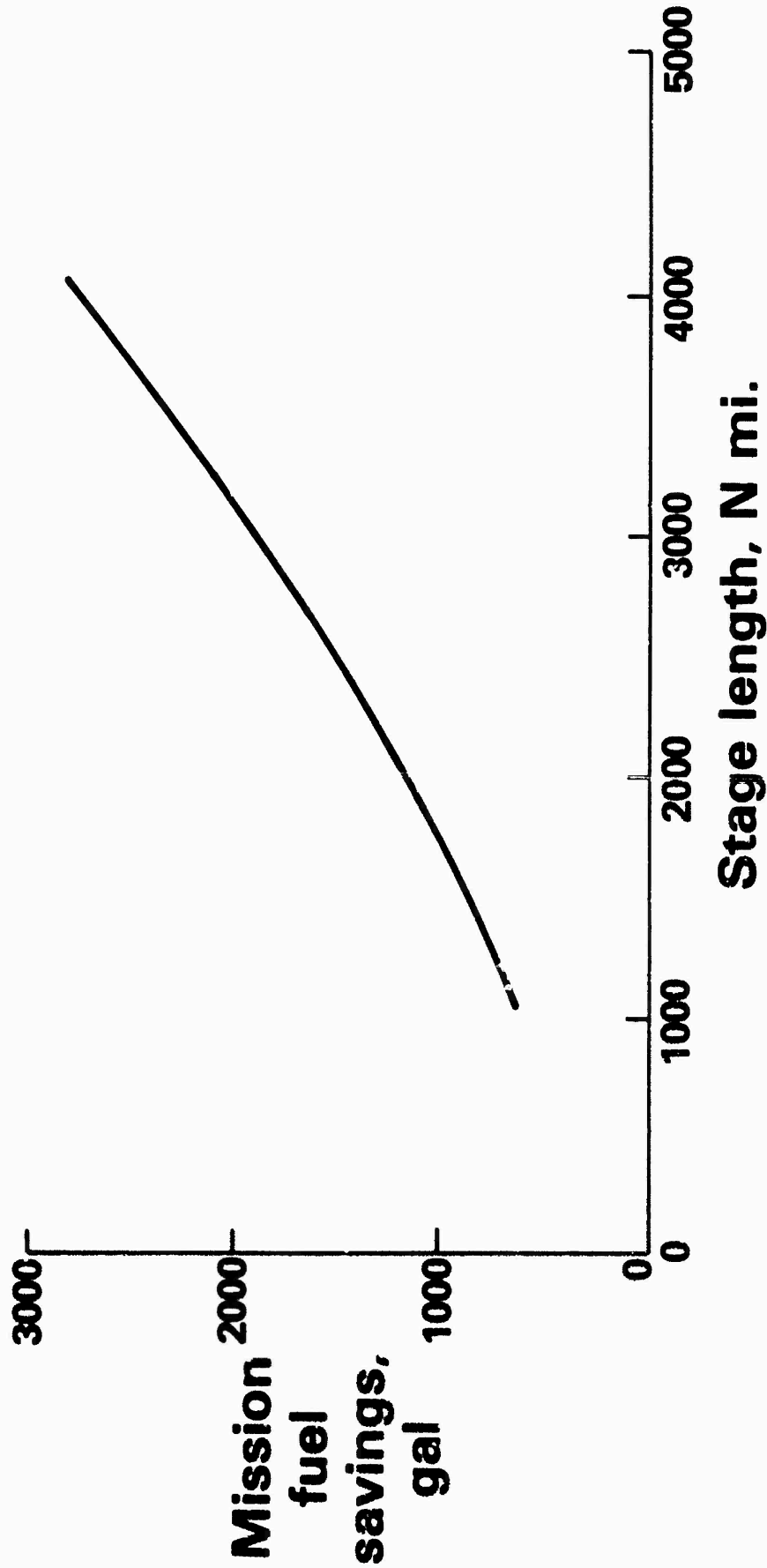

FIGURE 3 JT9D-7R4 EFFICIENCY COMPENSATES FOR CRAF WEIGHT PENALTIES

747-100 aircraft



In late 1984, the first PW2037 powered 757 will enter airline service. The fuel saving features of the PW2000 series engines are providing a new benchmark for high bypass ratio engine designs (Figure 4). The PW2037, to be introduced into the Delta and American 757 aircraft fleets, includes innovations in materials, aerodynamics, and controls technology which have permitted a step improvement from competing engines in both initial design performance and performance retention.

Technology defined in NASA's Aircraft Energy Efficiency program has contributed to the success of both the JT9D improvement program and the PW2037. The recently completed Engine Component Improvement element of NASA's ACEE program has speeded the incorporation of product improvements which led to the JT8D upgrades. Technology concepts explored as part of the Energy Efficient Engine program have been realized in the JT9D-7R4 and PW2037.

Although the successes of industry with help from NASA have been significant, one technical area with potentially the highest payoff has yet to be given an adequate examination. The advanced turbo-prop or "prop-fan", with propulsive efficiency 15-20% higher than turbofans bearing comparable core technology, could save six billion gallons of fuel during the 1990's alone if introduced in time to impact the next cycle of 80/140-passenger transport aircraft buys (Figure 5).

FIGURE 4

PW2037 INNOVATIONS SAVE FUEL

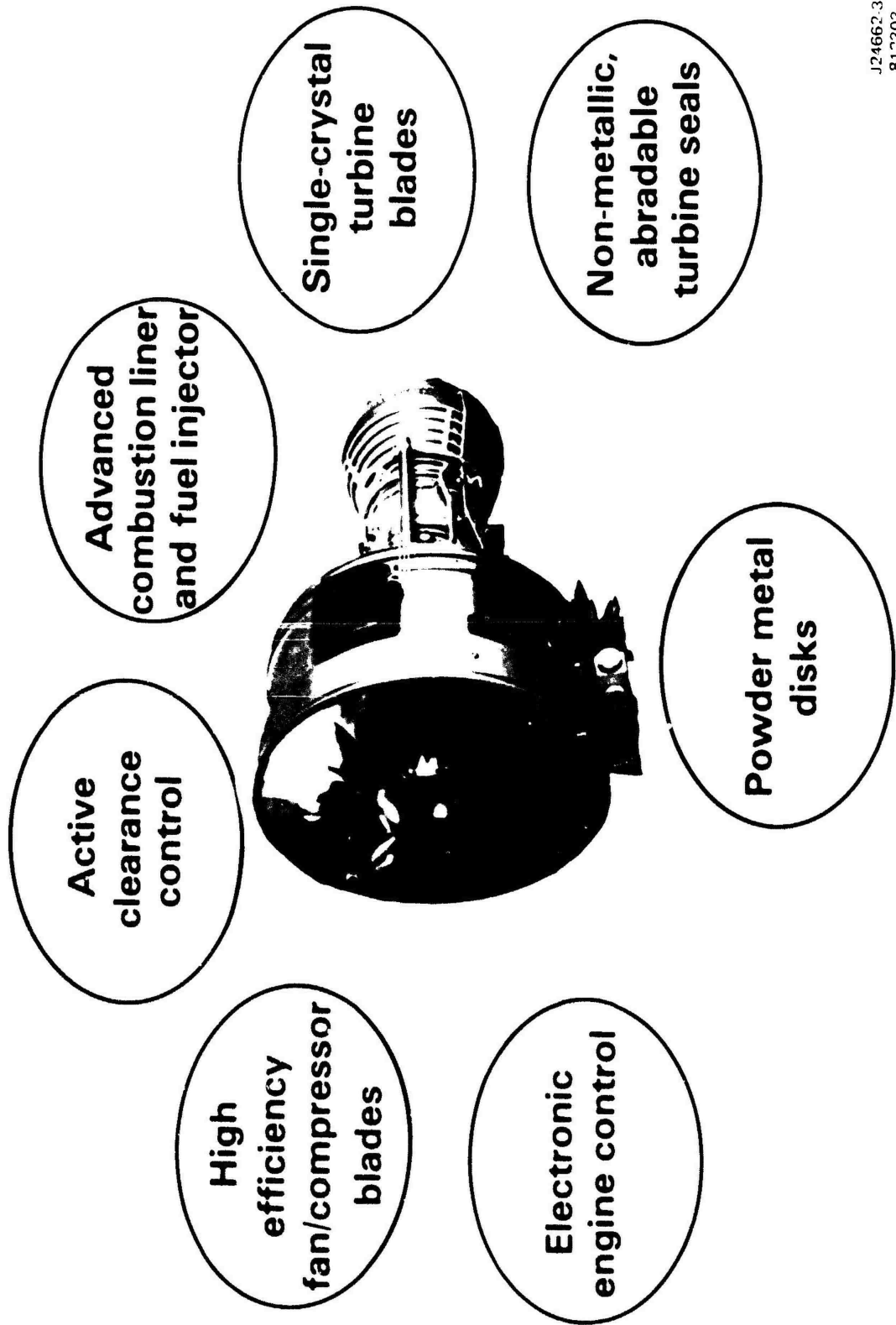
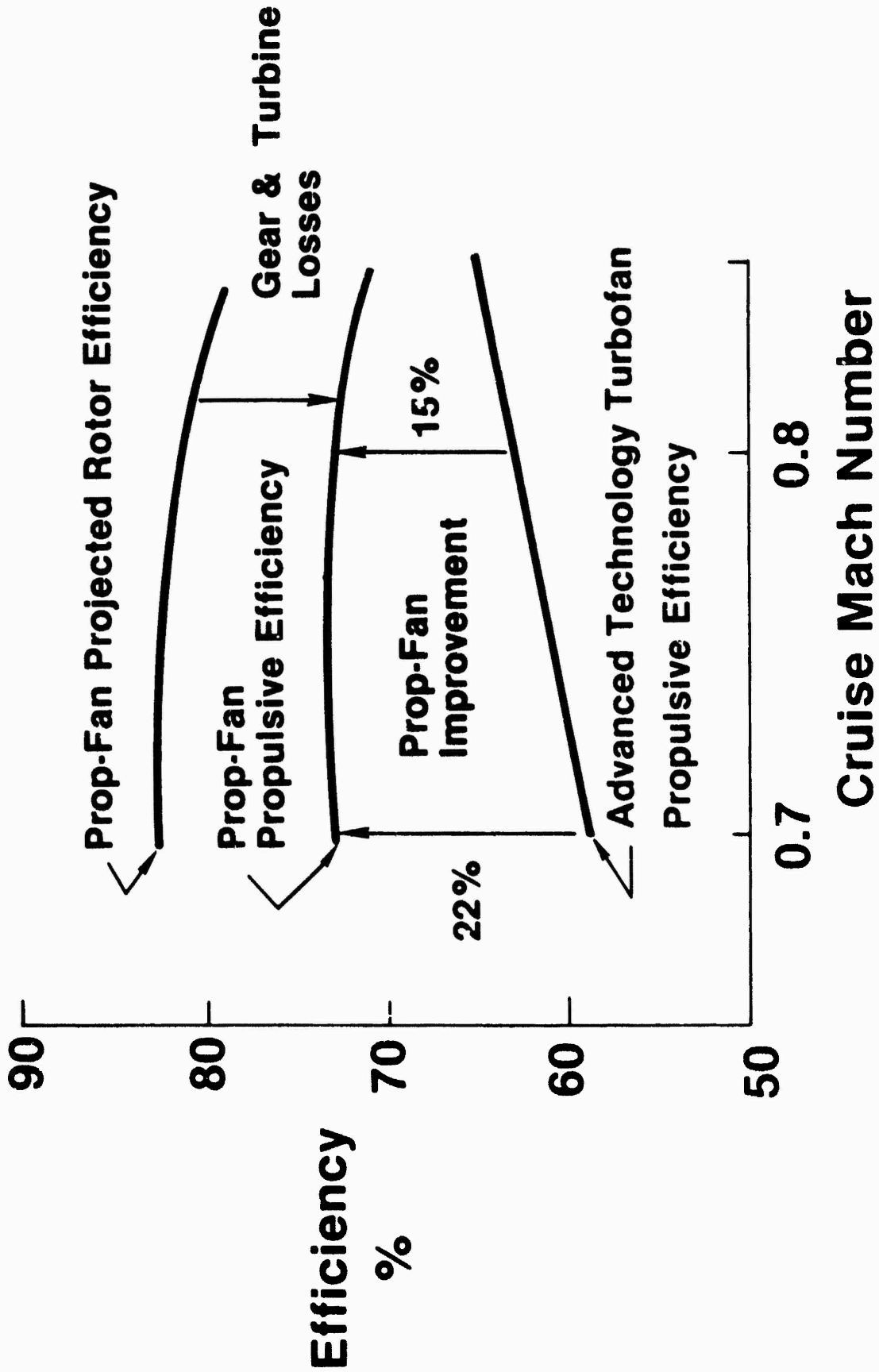

FIGURE 5

PROP-FAN EFFICIENCY ADVANTAGE



Proponents of an accelerated NASA program have recently testified before House and Senate Budget Authorization Committees in favor of an accelerated and expanded effort. The recommended accelerated/expanded NASA program provides the earliest possible date for technology readiness (1986) required prior to a product development commitment by industry (Figure 6). The consensus on the current program presently funded by FY86, is that it will not produce readiness for a production launch upon its projected FY88 completion date. The suggested enhancement will permit a fully-powered flight test two to three years earlier than the current plan. Evaluation of prop-structural integrity and/or acceptable cabin environment are the primary flight test goals. In addition, technology demonstration for engine components including a durable gearbox and inlet/compressor system along with overall propulsion system verification testing are included in the engine technology element (Figure 7). Even with a substantial NASA contribution to reducing technical risk, industry retains responsibility for the assumption of the business risks entailed in product development. Under the most optimistic assumption of NASA participation in the technology demonstration phase, government involvement still represents less than 10% of the ultimate cost of commercialization.

When technologies, representing a significant departure from current practices are on the horizon, the FAA, in addition to NASA, has an important role to play in fostering successful early introduction. Certification hurdles for new technology need to be identified. Issues of compatibility with existing facilities have to be addressed. Benefits to the overall transportation system for a given investment in government funds must be defined and compared with other energy conservation strategies being planned by the Department of Transportation.

FIGURE 6

ACCELERATED/EXPANDED NASA PROP-FAN PROGRAM RECOMMENDED

Current Timing

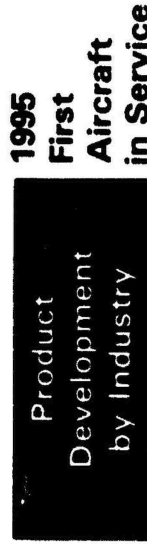

Recommended Timing

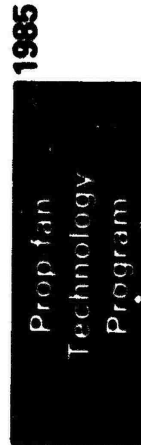
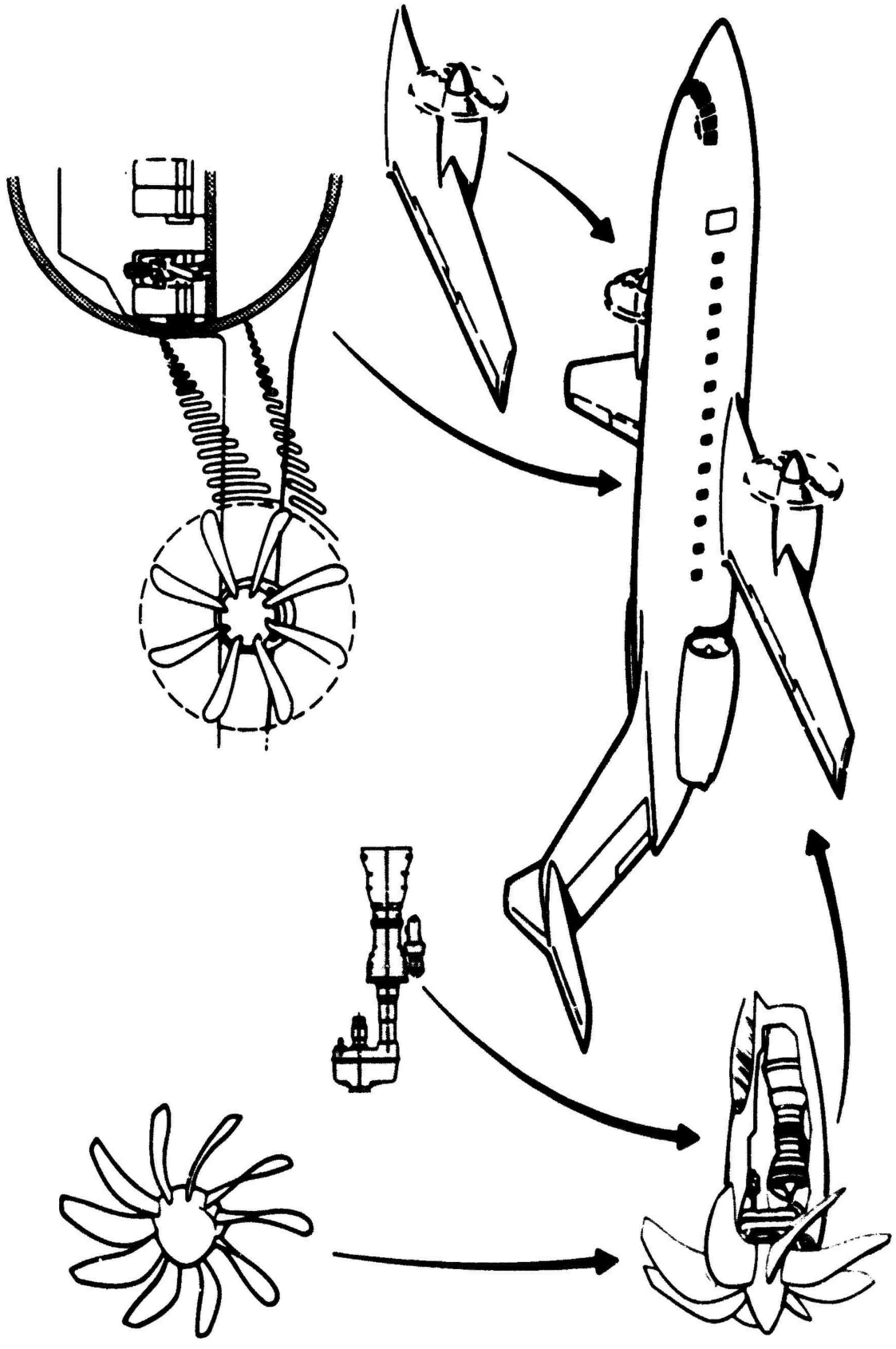

FIGURE 7
PROP-FAN TECHNOLOGIES



J24565-16
810603

The prognosis for Air Transport Energy Conservation which I have briefly outlined may differ in specific detail from the perspective others may bring to this discussion. What is most important, however, is that we share in the common view that the industry/government interface I have described forms a suitable role-model from which we can address future national needs. The degree to which that perception is shared by policymakers and the public will be a key determinant in our chances for success in meeting future energy conservation needs.

PANEL PRESENTATION

**Joseph C. Snodgrass, Jr.
Director, Aviation Programs
Aerospace Industries Association of America, Inc.**

RECORDING PAGE BLANK-NOT FILMED

I had not proposed to make a formal presentation today and Congressman Glickman just about wiped out my prefatory remarks, but let me leave a few thoughts with you.

There is no country in the world that is as dependent on air transportation as is the United States. Part of our highly effective air transportation system is due to the equipment that we have been able to furnish to it. The superiority we have been able to maintain in world markets has provided us with a production base that allowed us to expand our market hold and to develop the efficient equipment that we needed.

We are beginning to pick up organized competition from other sources. We feel that the United States is falling behind in our national research and technology programs to the point where we may lose our superiority to a greater degree than we would like to see.

We are solidly behind Congressman Glickman in his pointing out the need for very strong public support of a national research and technology program so that we can have in place the advances in technology in order to maintain our position in the world transport market.

Fuel efficiency is important among these technologies but I would caution you to keep in context that the fuel efficiency increases we are talking about here for transport aircraft or general aviation aircraft are not going to solve the overall national fuel shortage problem, mainly because the total amount of fuel used by air transport is very small compared to total U.S. consumption.

However, a small gain in fuel efficiency, as you have heard from other speakers, can do wonders for the economic strength and health of an airline or aircraft operator. It pays big returns. So we must continue to work in that area.

Our position as manufacturers is that we do not really believe we need much in the way of legislation or regulations to force the operators to adopt fuel conservation measures. We feel that the market will be the forcing factor in that area. So if we can have the continued public support of the technology, we can adapt the technology and I think we can sell it just on the fact that if you do not have it, your fuel prices are going to take you out of the market.

With that I will pass the microphone back and we can get on with our panel discussion. Thank you very much.

PANEL PRESENTATION

**Thomas E. Sheppard
Chairman, Air Traffic Control Committee
Air Line Pilots Association**

Good afternoon. I am very happy to be here this afternoon to represent the Air Line Pilots Association. For those of you who are not as familiar with ALPA as Mr. McKinzie is, we represent 33,000 air carrier pilots flying for 30 airlines.

One of the worst things about being last is that everyone has already said what you were going to say. Hopefully, I am going to say it just a little bit differently; and hopefully, I am going to reinforce in your minds some of the things I have heard these last two days.

I think we agree that gone are the days when a pilot can afford the luxury of adding 1,000 pounds of fuel for his wife and each of his kids in order to make sure he has enough fuel to complete his trip. As we have seen by the charts shown the last two days, the price of fuel has gone from 12 cents in 1972 to over \$1 a gallon in 1981.

At this conference we are talking about recovering one half of one percent of fuel flow as a viable alternative to reduce consumption. Seeing the crowd gather around Captain Anderson yesterday, after he showed his little gizmo for saving fuel, I thought Dolly Parton had suddenly come into the room. It is a very important subject and concerns us all. Fuel has become, as the Congressman said, the lifeline of the aviation industry and the critical factor by which the industry, if I could be dramatic, may live or die.

What can pilots and the aviation industry do? Where do we go from here? There are many things we can all do to make more efficient use of the fuel that is available to us. Some of these things have been mentioned the last two days. We may need additional (or better) instrumentation in the cockpit. Some things may only require a change in procedures, others will require changes in our thinking about the way we operate--this will probably be the hardest of all to do.

Areas where we can improve cover the whole spectrum of flight: from flight planning through departure, climb, cruise, descent, landing and post flight procedures. Let me take a quick look at each of these areas. I am only going to touch on a few items in each category as time doesn't allow for a complete listing even if we could make one. Some of the things I am going to mention are already being worked on.

In the area of flight planning we need the capability of better and more accurate weather forecasts at destinations and alternate airports. We need better winds aloft information. We need more accurate forecasts of ATC delays. We need more accuracy in fuel flow and fuel tank quantity gauges. With these aids we could carry less fuel, saving airline companies the cost of carrying extra fuel when it is not needed.

In the area of departures, gate hold procedures need to be standardized and implemented. Some airports go into gate hold after 10 minutes of delay, others 20, and others do not have gate hold procedures at all. Some airports need additional gate space to make the system operate efficiently. It doesn't do any good to have a jet sitting at a gate with its engine shutdown to save fuel while another jet sits on the ramp with its engines running waiting for the very same gate.

In the area of climb, the industry needs to standardize fuel efficient climb profiles and then educate (and I stress that word "educate") pilots and air traffic controllers about the reasons for, and the goals of the programs. We cannot operate efficiently if one carrier is climbing at 280 knots and another one is climbing at 340. We need an ATC system that allows us to climb high as fast as possible in order to get to a fuel efficient altitude quicker.

In the area of cruise, the industry and the ATC system need to develop and take advantage of direct RNAV routes. This is a valuable piece of equipment that is going to waste for the most part on airplanes today.

In the area of descents, ATC airspace needs to be redesigned to allow fuel efficient descents. The present FAA local flow traffic management program is a step in that direction but does not accomplish its goals because of lack of industry agreement and standardization coupled with lack of pilot and controller education as to the requirements and goals of the program.

Performance management systems, PMS, by themselves without a redesign of the ATC system and airspace and education of the pilot and the controller to its use will not save us any fuel.

In the area of landing, ATC delays need to be reduced and procedures need to be developed that will allow a pilot to land safely with less drag on the airplane or where drag would not be introduced until required or necessary. For example, our procedures today when we are making an instrument approach requires us to have our gear down and full flaps at the final approach fix inbound which is normally five to eight miles from the runway.

In the area of post flight, a system should be developed that can accurately tell a pilot how efficiently he has operated his flight. This should be an educational tool for the pilot and not used as punitive device. As Mr. McKinzie mentioned earlier, pilots are a very proud lot--you can talk to any of them and they will tell you they can beat any system going. They will need proof that the system works more efficiently than they do.

There are many more fuel saving possibilities I would like to discuss, but instead I want to stress two points to you. The first one is safety, with a capital "S." Keep that foremost in your mind as you are designing systems and procedures. Pilots have the responsibility for safety of their passengers and their aircraft. Because of this responsibility pilots will not accept any procedure or system that reduces the level of safety that has been achieved today.

The other thing I want to stress to you is training. If a pilot is not properly trained in whatever you are trying to accomplish, as Mr. McKinzie mentioned earlier, you will lose everything you worked so hard to gain. This also applies to the controller, when the procedure or the system affects him.

Now, how do we accomplish all of this? We need to sit down together, the industry, pilots, FAA, controllers, engineers, etc. This conference is a good example of that type of working together. All of us need to sit down, put aside petty differences and work for the good of all by developing procedures, systems and goals on an industry-wide basis that will safely allow pilots to carry and use less fuel. We need to be able and willing to accept new ways of thinking, new ideas, and be willing to get rid of that "not-invented-here" syndrome. We should also be willing to give these new procedures and ideas a try after they have been properly evaluated and tested. In other words, we need to sit down, talk, and really work together.

Thank you.

QUESTION AND ANSWER SESSION

CHAIRPERSON JOHN WESLER: Our format now is to open the floor to discussion, to questions, and possibly to short statements if any of you wish to make some. We want to make the rest of the afternoon meaningful for you to take advantage of those members of the panel who represent a rather broad spectrum of our aviation industry, make them available to you for questions at your convenience.

Once again may I ask you to use the microphone and to identify yourself and your affiliation, please, for the record. Sir?

MR. O'BRIEN: My name is Pat O'Brien of the Data Tech Corporation of New York. I have been here for both days and I want to commend the FAA and DOE for a fine seminar. However, I noticed that there was no discussion about the savings that could be achieved through the use of ground support equipment. I am talking about central systems.

This is something that has been going on for about five years and we are talking of savings in an APU of 99 percent and a GPU of 90 percent. Average air traffic costs for an APU runs \$30 to \$150 an hour; you can use a central system for \$.50 to \$1.00 an hour. So you are talking about pretty significant savings.

There are two questions I want to address to the FAA. One, are they aware of these programs that are taking place and two, are they also aware that because only the airlines are using these central systems, it is creating a problem for the small airports. The airlines cannot agree on one central system so the small airports do not have a central system. At the larger airports, all the airlines are putting in their own central system, so there is overlapping of central system efforts. In particular, in Atlanta I believe there are six central systems for 134 gates where one central system would do well. So they are saving although they are not saving as much as they can.

Thank you.

MR. HOCH: Thank you, Mr. O'Brien. First, yes, we are aware of the savings potential that is available through the use of ground support systems like this. As a matter of fact, there was an excellent presentation at the Transportation Research Board meeting in town about three or four months ago on ground support systems, and it was given, as you say, by the airlines. We followed it up and have gotten with our airports people for a determination about whether such systems might be eligible for our airport development aid program funds.

As you know, we do not have airport development aid program legislation at this point. We are awaiting it. But no determination has been made whether such systems are eligible. Can Federal funds be made available to install them? I think this is essential to their being utilized in an extensive, comprehensive manner.

We did mention yesterday in very fleeting treatment, the Washington National and Dulles Airport ground operating policies that FAA is working on right now. I would hope that we would get into this kind of thing as far as those two airports are concerned so that we can say to all of the airport proprietors out there here is an aspect that we addressed, why do you not do the same in the operation of your airport? I think that is important.

I think essential to the answer to your question is whether in fact Federal monies can flow towards the installation of this. Otherwise it is up to the airport proprietor to install it. The basic problem is that a profit can be made on the system, therefore, it becomes a legal question as to whether Federal monies can be made available for a project if the proprietor in turn can make monies on it.

I know that the airlines in the past have had a problem and I have heard it mentioned more than once that the airport proprietor has no primary purpose or reason or advantage in installing such systems because the fee that is paid by the airport proprietor for utilities is simply passed through to the airlines. That is a rap that I have heard repeated up to this point. I think that may coincide with your observation that you only see the airlines actively involved in this kind of activity. I would hope that that situation would change in the future.

* * * * *

MR. HORST: Dieter Horst, Lufthansa Airlines. What is the FAA's position concerning overweight landings? We know at least from Boeing airplanes, that Boeing airplanes are capable of landing overweight up to the max takeoff weight. You must recognize that still many airlines dump fuel or burn fuel instead of doing an overweight landing?

CHAIRPERSON WESLER: It is difficult to really answer that. That is a safety issue, not really in our area of responsibility.

I see no difficulty with landing at the maximum certificated landing weight. Obviously over that weight would be unsafe. This gets into the general area of airline planning, I believe, to insure against arriving at a destination with too much fuel.

MR. HORST: I think the statement from the Boeing Company is that landing overweight up to the max takeoff weight is not unsafe.

CHAIRPERSON WESLER: To the max takeoff weight?

MR. HORST: Yes.

CHAIRPERSON WESLER: Gordon?

MR. MC KINZIE: About all I can comment is I do not think the airplane is certified to do that. In the past Boeing has talked about safety implications and overweight inspections. We are certainly willing to go along if it is certified.

MR. HORST: There is an article in the Boeing Airliner, I think it was the beginning of 1980, which said this. That the airplane is capable of landing overweight provided the rate of descent is below six feet a second up to the next takeoff weight.

MR. MC KINZIE: Generally we have found that pilots that are landing overweight are making smoother landings than not but the issue is if it is certificated, we would be the first one to go by it.

MR. HORST: Many airlines in this country do this already.

MR. MC KINZIE: Do they do this?

MR. HORST: Yes.

MR. MC KINZIE: Landing overweight?

MR. HORST: Right.

MR. MC KINZIE: Yes, we do land overweight and take the penalties of the ensuing inspection and all of that sort of thing. We are saying we land overweight within the guidelines of the inspection that has to be done. However, to land at max gross takeoff weight if it is not certified, certainly would not be done.

MR. GORIN: I am Jim Gorin, SRI. You invited statements. I wanted to add to Mr. Snodgrass' presentation that the development of fuel efficient aircraft, the full implementation of ACEE program potentials is one of the most effective ways in which the American manufacturers can help maintain a cutting edge in the foreign competition.

VOICE: I am with KLM. I would like to make a little addition to the last speaker's words. I think it is a pity that although the technology is available to build aircraft, especially the wings may be 15 percent more fuel efficient than the present ones, at this point in time airlines cannot order a long-range wide-bodied aircraft having a fuel efficient wing although there is some 15 percent fuel to gain. Thank you.

VOICE: I wish to refer to the only airline practice that is specifically designed in order to burn more fuel. I think Mr. Hoch in his yesterday's presentation referred to tankering very briefly, of course. I understood that that was in the hands of the airlines. Of course to leave this thing in the hands of the airlines is quite dangerous because we try to minimize costs, we do not try to minimize consumption except in the case in which these two things coincide.

My question is do you see in the future any type of measure or general agreement or any other thing in order to avoid tankering?

MR. HOCH: Not from a regulatory sense, if that is what you mean. We broke up our policies in yesterday's presentation into two types. One was on the part of the agency. Those things that we had within our purview. They are mandatory as far as we are concerned. We are going to go ahead with those programs. They are basically aimed at improving the efficiency of the air traffic control system.

The other type of action was voluntary and a call for the industry to take action on their own. Tankering falls into this category. We have no intention to change the approach on that particular policy action.

CHAIRPERSON WESLER: Let me endorse that. We believe in a free enterprise system and the minimum regulation that is necessary is the best regulation.

CLOSING REMARKS

John E. Wesler, Director
Office of Environment and Energy
Federal Aviation Administration

PRECEDING PAGE BLANK-NOT FILMED

Yesterday, we opened the conference with a discussion of Federal programs, both DOE and FAA, which we are pursuing to conserve aviation fuel. We have also heard many interesting presentations by industry representatives concerning efforts to improve aviation fuel efficiency. Certainly the many contributions by Federal and industry programs have resulted in substantial energy savings thus far. We have just finished hearing what you, the users, consider to be the primary areas of concern for the future concerning aviation energy conservation. The purpose of this symposium was twofold: to inform you about our efforts and to listen attentively to your suggestions about where we should be going. I think we have certainly heard a lot these past two days!

There have been discussions in the past about inconsistencies or duplication of Federal programs. This conference, co-sponsored by the DOE and FAA, is one way of illustrating our intent to eliminate redundancy and to work together within the Federal sector and with the industry. There is no single solution to the energy shortage; a combination of solutions is necessary.

We are committed to the belief that the best decisions are those which result from discussion involving all viewpoints--before a direction has been chosen and positions hardened. You, the users of the National Aviation System, must be full partners in the dialogue which shapes our future as well as your own.

Your participation in this conference is deeply appreciated, and I invite your continued input and support in finding new ways to conserve energy and improve efficiency.

Thank You!