

AD-A107 380

ARMY ENGINEER TOPOGRAPHIC LABS FORT BELVOIR VA
HIGH-SPEED LASER PLAYEMAKING FROM DIGITAL DATA FOR THE DEFENSE --ETC(U)
NOV 81
EIL-RUzb

F/G 14/5

UNCLASSIFIED

NL

100
100
100



END
DATE
FILMED:
12 R
DTIC

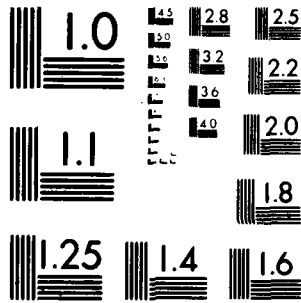

MICROCOPY RESOLUTION TEST CHART
NATIONAL BUREAU OF STANDARDS 1963 A_v

UNCLASSIFIED

SECURITY CLASSIFICATION OF THIS PAGE (When Data Entered)

LEVEL II

REPORT DOCUMENTATION PAGE

READ INSTRUCTIONS
BEFORE COMPLETING FORM

1. REPORT NUMBER R026		2. GOVT ACCESSION NO. 14 ETL-R026 ADA107 380		3. RECIPIENT'S CATALOG NUMBER	
TITLE (and Subtitle) 6 High-Speed Laser Platemaking from Digital Data for the Defense Mapping Agency				5. TYPE OF REPORT & PERIOD COVERED Paper	
AUTHOR(s) Joe Honablew				6. PERFORMING ORG. REPORT NUMBER	
PERFORMING ORGANIZATION NAME AND ADDRESS				8. CONTRACT OR GRANT NUMBER(s)	
1. CONTROLLING OFFICE NAME AND ADDRESS JSA Engineer Topographic Laboratories ATTN: USAETL-LO Ft. Belvoir, VA 22060				10. PROGRAM ELEMENT, PROJECT, TASK AREA & WORK UNIT NUMBERS	
4. MONITORING AGENCY NAME & ADDRESS (if different from Controlling Office)				12. REPORT DATE 11 6 Nov 81	
				13. NUMBER OF PAGES 15	
				15. SECURITY CLASS. (of this report) 17 17	
				15a. DECLASSIFICATION/DOWNGRADING SCHEDULE	

AD A1 U7380

16. DISTRIBUTION STATEMENT (of this Report)
Approved for public release; distribution unlimited.

17. DISTRIBUTION STATEMENT (of the abstract entered in Block 20, if different from Report)

18. SUPPLEMENTARY NOTES

DTIC ELECTE
S NOV 18 1981 D

19. KEY WORDS (Continue on reverse side if necessary and identify by block number)
raster scanning
Digital Laser Platemaking
large format
UV energy
Film exposure

20. ABSTRACT (Continue on reverse side if necessary and identify by block number)
A Digital Laser Platemaker will significantly reduce the time and cost for producing standard and special purpose maps that are now printed by lithographic methods. This platemaker, developed at the U.S. Army Engineer Topographic Laboratories (USAETL) Ft. Belvoir, VA. will expose a 41- by 59-inch image on a diazo-coated press plate in 15 minutes by using an Ultra Violet (UV) laser and digital data input via magnetic tape. Plates will be exposed while they are held on the internal surface of a stationary drum after it is loaded by a semi-automatic mechanism. The system can also produce film plots for archival

DTIC FILE COPY

DD FORM 1473 1 JAN 73

EDITION OF 1 NOV 65 IS OBSOLETE

UNCLASSIFIED

SECURITY CLASSIFICATION OF THIS PAGE (When Data Entered)

403-192

UNCLASSIFIED

SECURITY CLASSIFICATION OF THIS PAGE(When Data Entered)

Block #20 cont.

storage of graphic images.

UNCLASSIFIED

SECURITY CLASSIFICATION OF THIS PAGE(When Data Entered)

HIGH-SPEED LASER PLATEMAKING FROM DIGITAL DATA FOR THE DEFENSE MAPPING AGENCY

Joe Honablew
Automated Cartography Branch
U.S. Army Engineer Topographic Laboratories
Ft. Belvoir, Virginia 22060

BIOGRAPHICAL SKETCH

Joe Honablew is a Cartographer at the U.S. Army Engineer Topographic Laboratories. His research and development areas include serving as Project Engineer for the development of the Digital Laser Platemaker and computer software for three-dimensional scene generation from digital data. He began working in mapping, charting and geodesy in 1961, at the Army Map Service. He has been with ETL since 1970. Mr. Honablew has a B.S. in Cartographic Science from George Washington University.

ABSTRACT

A Digital Laser Platemaker will significantly reduce the time and cost for producing standard and special purpose maps that are now printed by lithographic methods. This platemaker, developed at the U.S. Army Engineer Topographic Laboratories (USAETL) Ft. Belvoir, VA. will expose a 41- by 59-inch image on a diazo-coated press plate in 15 minutes by using an Ultra Violet (UV) laser and digital data input via magnetic tape. Plates will be exposed while they are held on the internal surface of a stationary drum after it is loaded by a semi-automatic mechanism. The system can also produce film plots for archival storage of graphic images.

Accession For	
NTIS GRA&I	<input checked="" type="checkbox"/>
DTIC TAB	<input type="checkbox"/>
Unannounced	<input type="checkbox"/>
Justification	
By	
Distribution/	
Availability Codes	
Dist	Avail and/or Special
A	

DTIC
ELECTE
S NOV 18 1981 D
D

8111 16 037

DISTRIBUTION STATEMENT A
Approved for public release
Distribution Unlimited

INTRODUCTION

The Defense Mapping Agency (DMA) is undergoing a transition from the analog approach of producing maps and charts to digital techniques. These digital techniques consist of the familiar line-following (vector to digitizing) with a hand held cursor and high-density, high-speed raster scanning. The current activities and futuristic planning at DMA suggest that a total transition to digital mapping techniques will indeed be a reality. Data gathering and data handling will be accomplished with digital computer controlled hardware and although some output will occur on electronic displays, the need for lithographically reproduced hard copy will still exist. Both digital and analog techniques are being employed by DMA and therefore their map and chart production could be considered in a "hybrid" stage.

In recognizing the need for a continuing use of lithography, DMA embarked on a developmental effort to produce press-ready plates directly from digital data. Although cost and time savings are intrinsic considerations in the development of a digital platemaking system, an even more compelling motivation is that the data produced by DMA will be, for the most part, digital. It follows that a digital output capability for platemaking should be developed.

Studies were conducted through contracts with commercial organizations and in-house efforts at ETL before R&D efforts were initiated to determine a viable approach to digital platemaking within the DMA.

ETL awarded a contract to the EOCOM Corporation, manufacturer of the LASERITE^R plate exposing system, to develop and deliver a Digital Laser Platemaking System (LPM) that would be capable of handling large format plates (48-by-60 inch). The image recording was not to exceed 15 minutes, and a $\pm .002$ inch accuracy over the entire format had to be maintained. The system was delivered to ETL in March, 1981 fig. 1. It is now undergoing engineering test. This test and evaluation period will continue for approximately one year in order to determine what modifications, if any, are required for a full production model.

1000

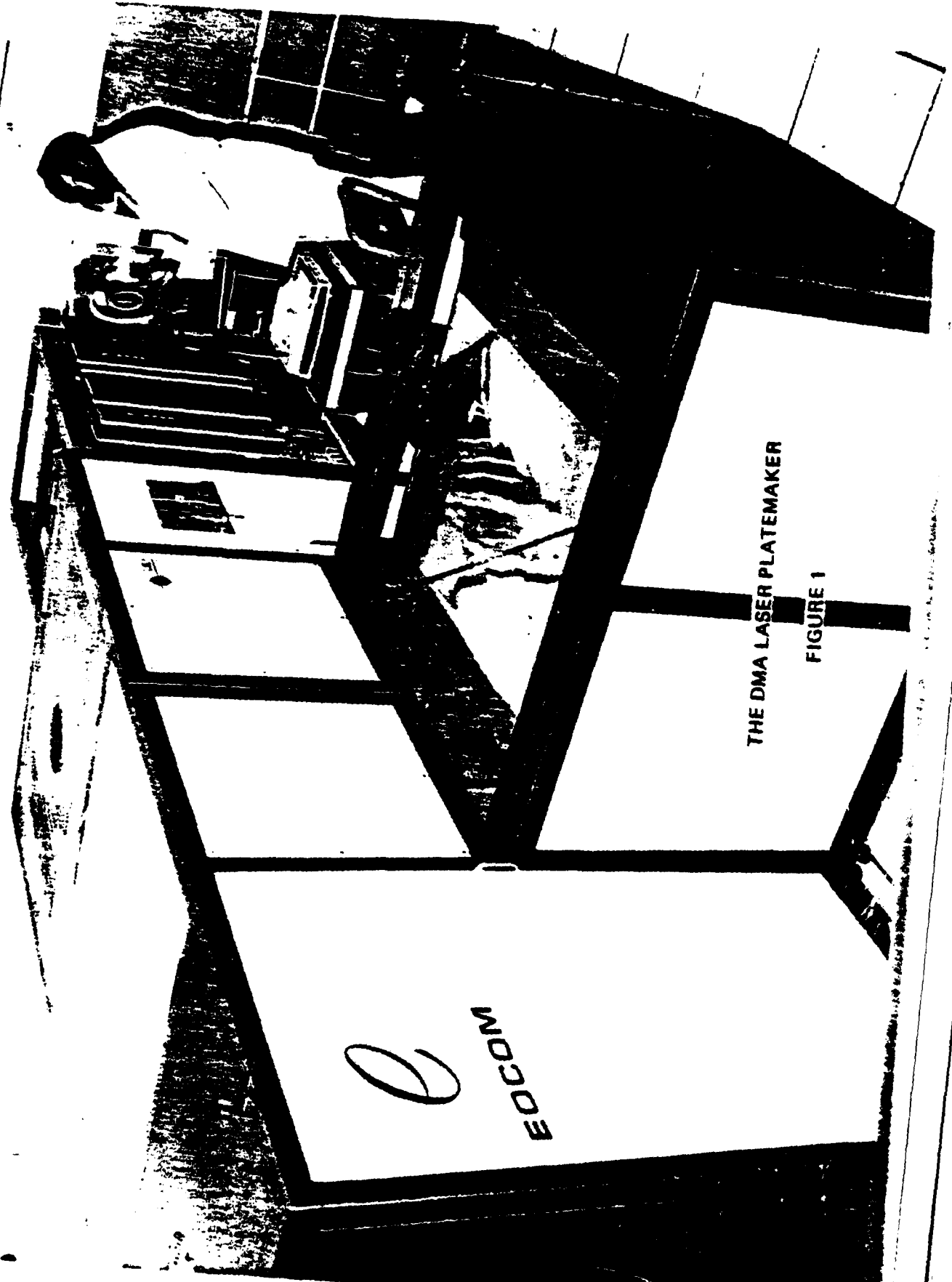

THE DMA LASER PLATEMAKER

FIGURE 1

E
EDCOM

SYSTEM CONFIGURATION

The DMA Laser Platemaking System consists of six major subsystems fig. 2. These subsystems, although independent in nature, combine in performance to produce an image on a medium that is photosensitive to UV energy.

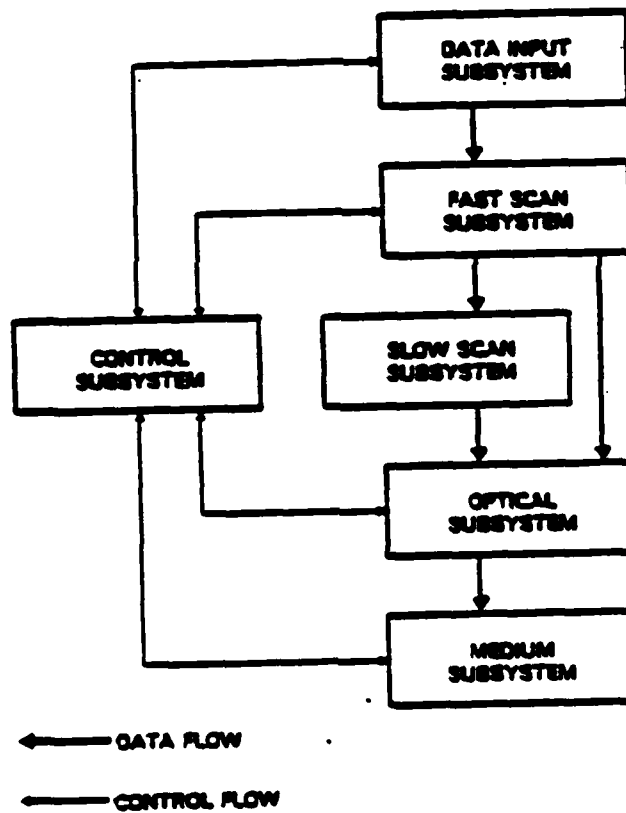

SUBSYSTEMS
FIGURE 2

CONTROL SUBSYSTEM

The Control Subsystem manages a complex sequence of actions that are performed by various elements of the system. These actions, occurring as a result of timely electronic communications, are necessary to cause imaging on the medium being exposed. Most of the actions are automatic, however, there are several independent manual controls that are available for use at the option of the operator. These include: (1) power on/off switch that controls the power required for system operations; (2) positive/negative switch that enables the operator to select either a positive or negative exposure; (3) a medium thickness switch that enables the operator to compensate for the varying thickness of the different output medium, and (4) emergency stop or "panic" button that enables the operator to totally shut down the system in case of a severe emergency.

The computer that is used for the controller is a Digital Equipment Corporation PDP 11/34 with 64K of memory.

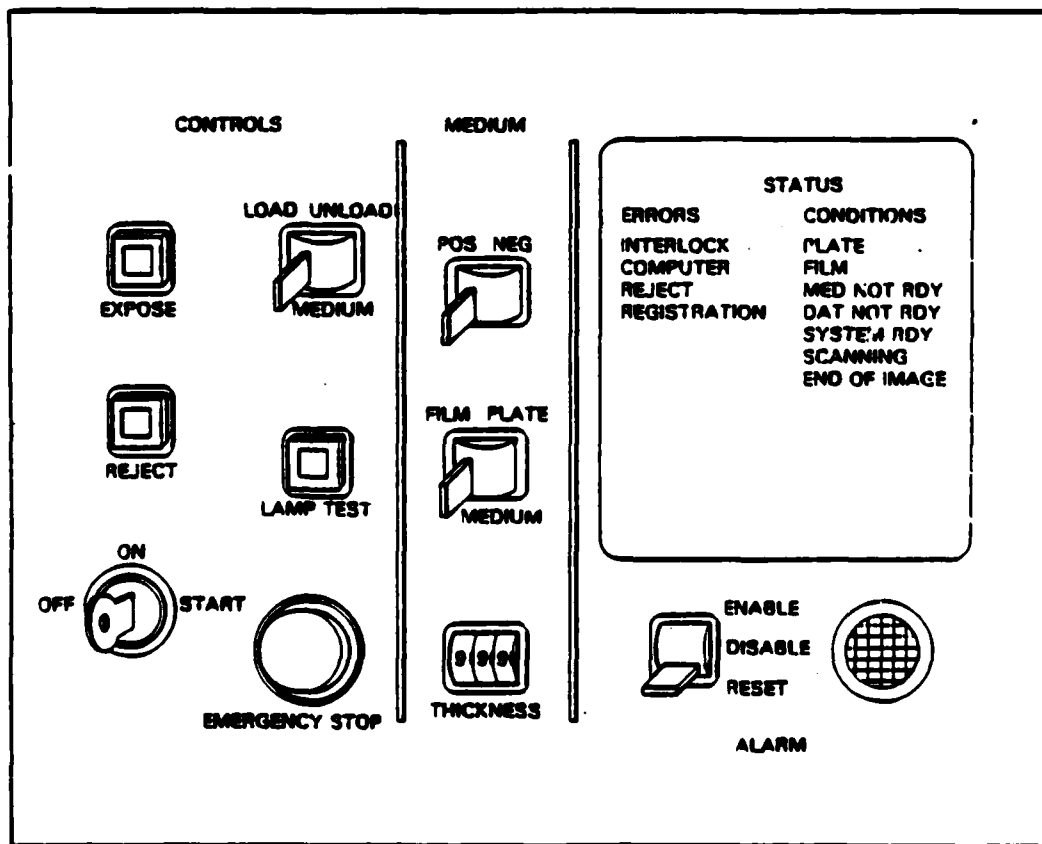

DATA INPUT SYSTEM

The data input subsystem uses these principal functions:

1. It reads digital image data from magnetic tape in compressed Run Length Coded, (RLC) or direct binary formats.
2. It buffers the data to correlate its rate of transport to the rate of image processing which is substantially slower than the tape inputs.
3. It decompresses the data to an image format that has one bit indicating black or white, for each pixel.
4. It transmits the data to the laser exposure/optical subsystem.

A pre-requisite for starting the system-imaging sequence is tape loading and data startup procedures. These procedures are performed by the operator who is prompted by interactive commands from the PDP/11 computer software. During the imaging sequence, the data subsystem supplies pixel data on demand to the optical subsystem. In all other respects, the data subsystem is under control of the PDP/11 computer software.

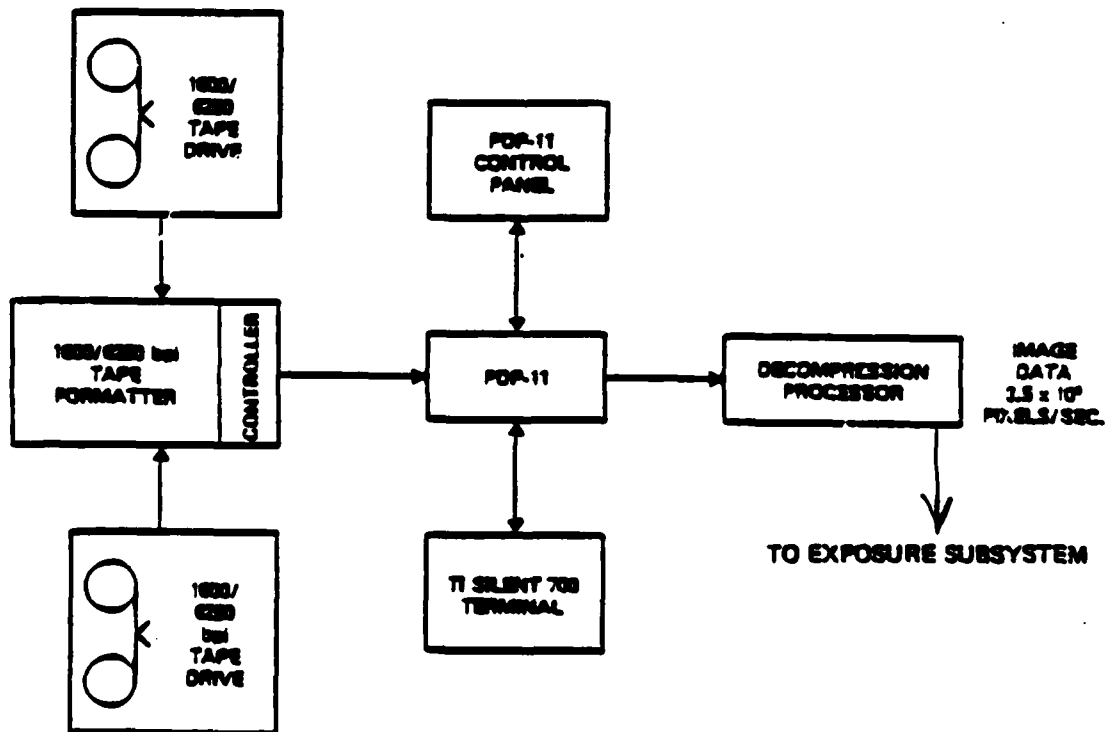

DATA INPUT SUBSYSTEM
FIGURE 3

MAGNETIC TAPES

The magnetic tape subsystem employs a pair of Telex Model 6250 tape units. They read and write data at 1600 or 6250 BPI with a maximum tape speed of 125 IPS for a peak data rate of 0.9×10^6 bytes/second. The maximum recording density packs approximately 1.6×10^8 data bytes on a 2400 foot reel of tape. This in turn equates to nearly 2.5×10^9 pixels on a full size (41- by 59-in.) image

The data on the magnetic tapes are highly compressed and must be decompressed before being used by the LPM system. This is achieved with a microprogrammed special purpose digital processor that decompresses the data and outputs video information to the Laser Exposure Subsystem (LES). The decompression processor drives the serial data line to the LES as a function of the status of the digital input and the (LES). If the scan head has been positioned by the results of timing curcuitry and if there is sufficient pixel data in the PDP/11 buffers, a scan line will be written on the recording medium.

FAST SCAN SUBSYSTEM

The fast scan subsystem controls the left-to-right or "X" direction motion of the laser spot across the surface of the recording medium. This direction has the medium's longest dimension (59 inches) and represents 59,944 pixel locations in each scan line. The data are plotted at 3.5×10^6 pixels/second at 80 percent duty cycle.

The modulated laser beam is directed onto a 45° rotating mirror that is affixed to a synchronized scanning motor fig. 4. The mirror is rotating at approximately 46 revolutions per-second while directing the laser beam 90° to the surface of the medium being exposed.

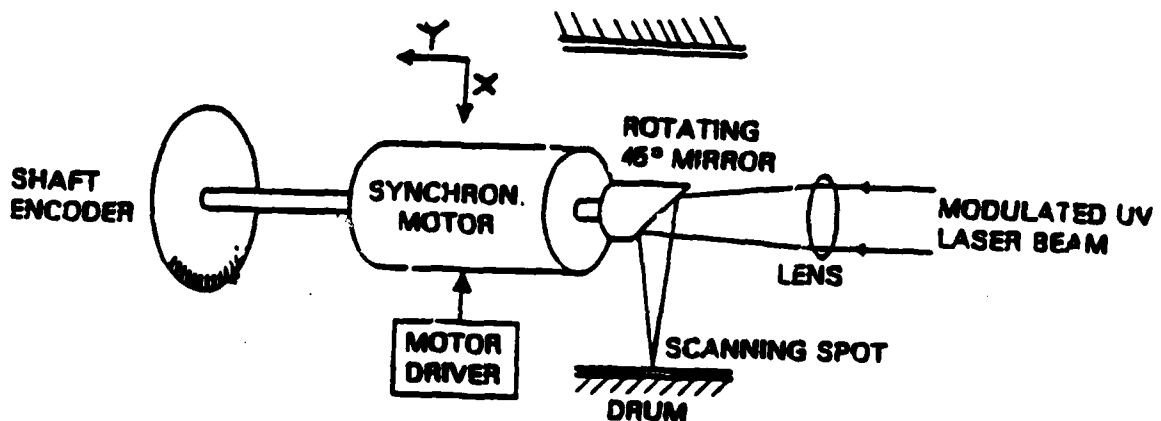

FAST SCAN SUBSYSTEM
FIGURE 4

SLOW SCAN SUBSYSTEM

The slow scan subsystem moves the rotating mirror along the drum axis and causes successive lines of the image raster to be written at 25 micrometer intervals from top to bottom of the medium (Y-axis). The scanning mirror, shaft encoder, and focusing lens all ride on a carriage guided by a dove-tail slide and driven by a lead screw.

The Y-axis is the shorter dimension (41 inches) of the medium and represents 41,656 pixel locations from top to bottom.

Total travel time in the Y direction for a full format scan is approximately 15 minutes. This does not include the time required for the scanner head to move from the home position to the first scan line (approximately two minutes).

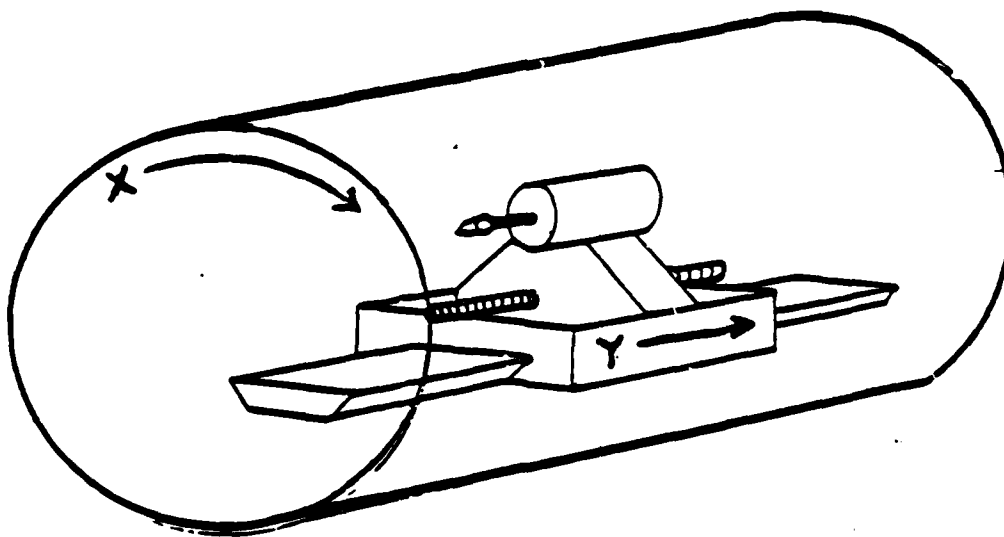

SLOW SCAN SUBSYSTEM
FIGURE 5

OPTICAL SUBSYSTEM

The optical subsystem fig 6 generates, modulates and directs the UV energy that exposes the photosensitive surface of the recording medium. It consists of a shutter, modulator, lenses and coated glass flats which act as filters or mirrors.

An Argon-ion laser, built by Coherent, supplies the energy for the system. The wave length of the emitted energy is 351 and 364 nanometers. The laser head also contains a sensor for measuring output power which is approximately 1.5 watts at the head. The total energy available at the medium after losses from the modulator and the optics is approximately 750 MW. The two position neutral density filter causes beam attenuation of approximately 1000:1 for film exposure.

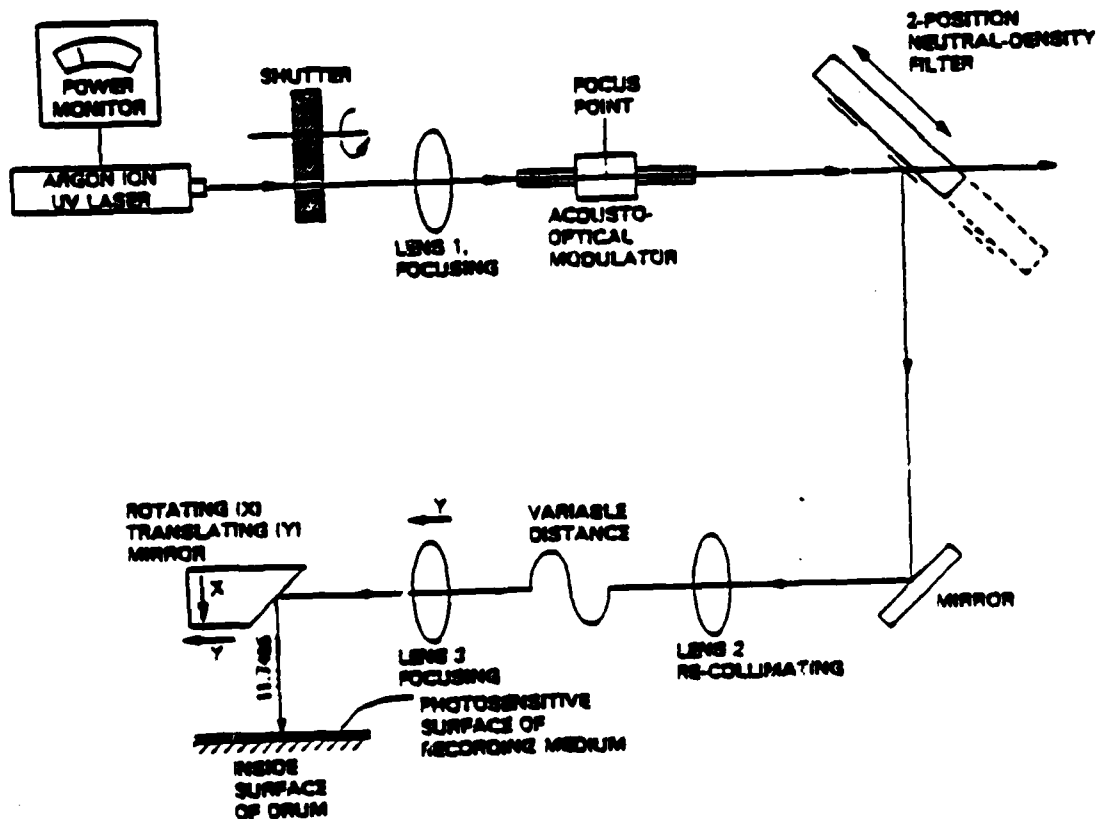

OPTICAL SUBSYSTEM
FIGURE 6

MEDIUM LOADING SUBSYSTEM

The medium loading subsystem is a mechanism for transporting the plates or film into the stationary drum. Initially, the carrier, a thin porous sheet of stainless steel, lies flat and, for the most part, accessible on a loading table. The operator places the medium over a pair of registration pins that are attached to the carrier. Also attached to the carrier, at the leading edge is a clamping device called a foot. This foot is also attached to two rings located just inside and at both ends, of the drum. The purpose of the foot is to grasp and hold the medium while loading.

As the rings rotate, the edges of the carrier wrap around them causing the carrier and medium to enter the drum, roll up into cylindrical form fig. 7 and completes the loading process.

After the medium is located and comes to rest upon mechanical stops, vacuum is applied from several ports serving circumferential grooves in drum. This vacuum clamps the medium and holds it firmly in place against the interior surface of the drum during exposure.

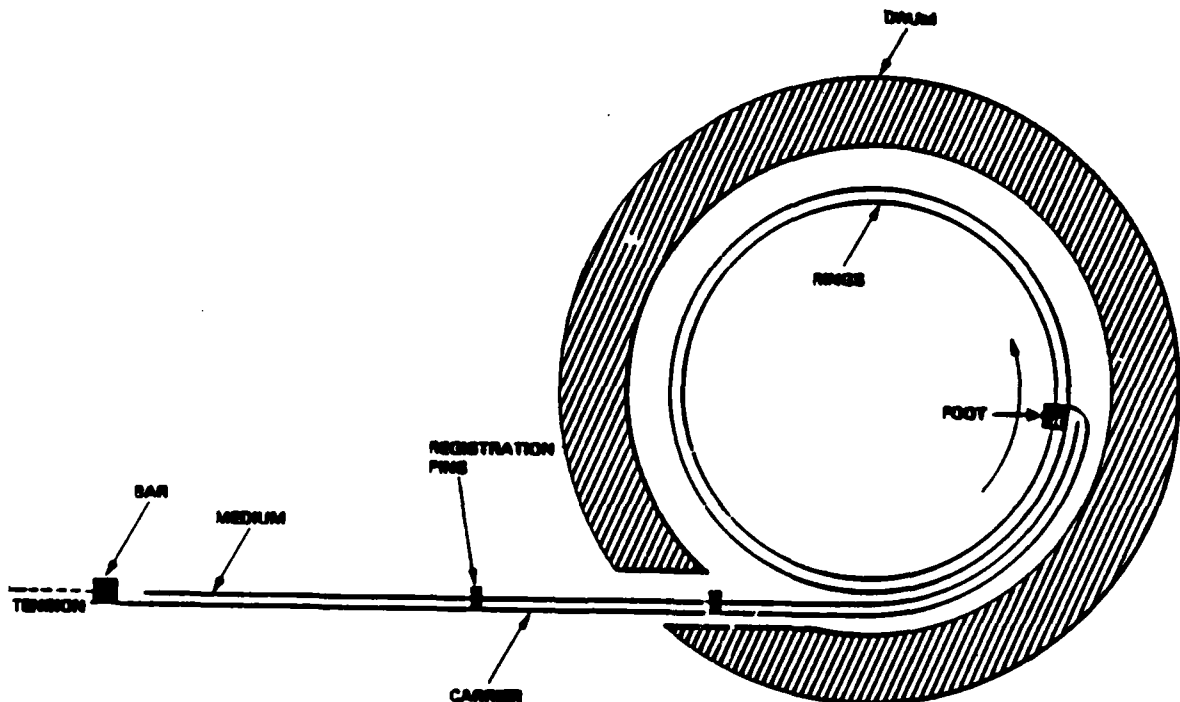

MEDIA LOADING
Figure 7

**TABLE 1
DMA LPM SPECIFICATIONS**

MAGNETIC TAPE	NUMBER	TWO TAPE UNITS
	REEL SIZE	2400 FEET
	SPEED	125 INCHES/SECOND
	DENSITY	1600 AND 62500 BYTES/INCH
RECORDING	FORMAT	BINARY/RUN-LENGTH CODED
	FILM	FULL EXPOSURE = 10^{-6} JOULES/CM²
	PLATE	FULL EXPOSURE = 10^{-3} JOULES/CM²
	SIZE	UP TO 1.2 METERS X 1.4 METERS (48 INCHES X 60 INCHES)
	THICKNESS	.004 TO .020 INCHES
EXPOSURE RADIATION		ULTRA-VIOLET IN THE RANGE TO 351 TO 364 NANOMETERS
EXPOSURE TIME		15 MINUTES, INDEPENDENT OF IMAGE CONTENT
IMAGE FORMAT		59,944 X 41,656 PICTURE ELEMENTS AT 25 MICROMETER SPACING
OVERALL SYSTEM DIMENSIONS	LENGTH	172 INCHES
	WIDTH	105 INCHES
	HEIGHT	72 INCHES

ALIGNMENT AND REGISTRATION

Design features and functions of the LPM assure precision in placing the exposed image on the recording medium. The top edge of the carrier has a pair of registration pins that fit into two slots in the recording medium (figure 7). These pins prevent skewing of the medium with respect to the carrier in the loading process and they make certain that the line passing through the center of the slots lies along the drum circumference when the medium is loaded.

Located on the medium along the same line as the two slots and equidistant from them, is a round registration hole approximately .250 inch diameter. This hole coincides with similar size holes in the ring and with the drum when the medium is fully loaded. The design of the registration hole is such that as the laser beam penetrates these holes simultaneously, it reaches a photodetector. The registration circuitry uses signals from the photodetector, a shaft encoder and a data clock generator to locate the vertical and horizontal centerline of the registration hole. The position of the registration hole center determines the locations of the first and subsequent scan lines.

PRELIMINARY TEST RESULTS

Engineering tests are on-going at ETL with encouraging results. Since this system is a prototype, tests are expected to continue for approximately twelve months. After the testing is finished, quantitative results will be published. We have printed a four color test map from press plates made from digital data on the LPM. Line quality and registration were excellent. The plates used for the map were presensitized 48-by-60 inch Kalle N-8 aluminum plates.

Although we currently have a limited amount of experience using wipe-on-coatings, we are encouraged by the results of two test exposures: One using a wipe on coating by Litho-Chem, and the other using an in-house synthesized coating.

More testing must be made in order to statistically validate the system's performance in terms of accuracy. Initial tests however, show the image distortion and repeatability tend to approach the purchase description requirements.

We also believe this map to be the first of its kind in that it was completely digital to plate without the use of lithographic negatives for platemaking.

CONCLUSION

Considering the prototype nature of the DMA Laser Platemaking System, our limited testing has indicated that computer to plate platemaking is practical. Additional testing will determine just how valid our assumptions are for actual map reproduction at DMA.

END

DATE
FILMED

12-8

DTIC