

MICROCOPY RESOLUTION TEST CHART
NATIONAL BUREAU OF STANDARDS-1963-A

LEVEL II

THE **BOEING** COMPANY
CODE IDENT. NO. 81205

2

THIS DOCUMENT IS:

CONTROLLED BY 3-7593

ALL REVISIONS TO THIS DOCUMENT SHALL BE APPROVED BY THE ABOVE ORGANIZATION PRIOR TO RELEASE.

PREPARED UNDER CONTRACT NO.
 IR&D
 OTHER

AD A107436

DOCUMENT NO. 114 D3-11158-1

MODEL

TITLE DESIGN AND FABRICATION OF COANDA SUPPRESSOR FLOW
VISUALIZATION MODEL

ORIGINAL RELEASE DATE 2-23-77

ISSUE NO. TO

DTIC ELECTE
NOV 13 1981

1 - 11.6 77

37

PREPARED BY Dale W. Brees
SUPERVISED BY William F. Schmidt
APPROVED BY W. W. Masby

75930 Feb. 10, 1977
2/10/77
2-17-77

DISTRIBUTION STATEMENT A
Approved for public release
Distribution Unlimited

DTIC FILE COPY

81 9, 1977 9

LIST OF FIGURES

<u>Figure Number</u>	<u>Title</u>	<u>Page</u>
1	Three-Dimensional Coanda Model - Test Setup.....	10
2	Flow Field Summary.....	14
3	Flow Field Side View.....	15
4	Flow Field End and Top Views.....	16
5	Comparison of Coanda Theory to Arena Model Test Data.....	20
6	Coanda Exit Mach Number Profiles.....	21

1.0 SUMMARY

Because the Navy Coanda noise suppressor exhibited three-dimensional flow anomalies a 1/20th scale transparent laboratory model was fabricated to provide for visualization of the internal flow. Identification of flow anomalies and methods of correcting them by geometric design changes thus eliminating local acoustic lining erosion was the primary purpose for the model. In addition, model experimental flow data were to be correlated to analytical computer codings so they could be applied to Coanda suppression system designs with a higher level of confidence.

The 1/20th scale transparent model was fabricated and installed in the Boeing-Wichita air laboratory. Several checkout runs were made and the functional capability of the system was verified. These checkout runs showed that the model accurately represents the full scale flow and recirculation that had been deduced from the full scale demonstration tests.

2.0 BACKGROUND

The Navy Coanda noise suppressor is a three-dimensional flow system that was designed using two-dimensional and axisymmetric analysis techniques and model tests of individual components. The full scale suppressor system indicated flow instabilities within the enclosure that could not be defined analytically or visually. The flow anomalies resulted in areas of lining erosion and temperature deterioration in a few locations.

3.0 OBJECTIVE

The objective of this study was to build and test a transparent 1/20th scale model of the Navy Coanda suppressor to observe anomalous flow regions and characteristics. After identification, these flow anomalies would be corrected, if possible, by geometric design changes. In addition, Coanda and ejector set experimental data from the 1/20th scale model were to be correlated to analytical Coanda and ejector computer codings. This would lead to full scale analytical design techniques that could be used with a high level of confidence.

4.0 DESIGN AND FABRICATION

The Navy Coanda ground jet noise suppressor model work was planned by these three phases:

1. To fabricate a 1/20th scale transparent model and demonstrate its function
2. To develop model instrumentation and flow visualization techniques
3. To modify and test the model to improve flow characteristics

Phase 1 fabrication was completed and a brief functional check and demonstration was performed on April 5, 1976. Phases 2 and 3 have not been accomplished due to limited funding.

4.1 Full Scale Navy Coanda Suppressor

The full scale Navy Coanda suppressor was sized to accommodate current and anticipated Navy jet engines. The design drawings of the Navy Coanda full scale suppressor are 1/20th scale; hence, the model scale was established so that templates could be made from the drawings. These drawings are presented in Appendix B in a scale of .03 of full size.

4.2 Transparent Coanda Model

The model was fabricated from plexiglas to provide maximum visibility of the internal structure and compartments. This model simulated all the components including secondary air intakes and ejectors. The Coanda surface and removable sidewalls were also transparent. The ejectors are metal using previously fabricated components. A nozzle simulating the J57-P-21 at afterburning was designed to use shop air at a pressure ratio of 2.22 to simulate

the full scale nozzle Mach number. Figure 1 presents a sketch of the completed model and airflow system. A photograph of the transparent model is included as Appendix A.

5.0 FUNCTIONAL DEMONSTRATION

5.1 Laboratory Setup

The laboratory setup is illustrated on Figure 1 and the photograph in Appendix A. Flow related parameters for the model and full scale demonstrator are compared in Table 1. The model was assembled in the Boeing-Wichita air laboratory and connected to plant air. Photographs were made of the Coanda and of the assembled model suppressor system and test setup.

TABLE 1
COMPARISON OF MODEL AND FULL SCALE PARAMETERS

PARAMETER	MODEL	FULL SCALE
Scale	1/20	1
Nozzle diameter, in	1.39	27.964
Engine pressure ratio (P_{Tnoz}/P_{amb})	2.22	2.22
Nozzle exhaust temperature, °F	60	3000 - 3200
Exit velocity, ft/sec	1118	2595
Viscosity, $lb_m/sec\ ft$	1.06×10^{-5}	3.92×10^{-5}
Density, lb/ft^3	0.10256	0.0153
Reynolds number, $\times 10^{-5}$	11.4	23.4
Airflow rate, lbs/sec	1.12	172

A smoke generator crucible was placed inside the enclosure beneath the ejectors and outside the enclosure near the nozzle exit. String tufts were taped to the floor, ceiling and to the inside of the stack walls. A pressure gauge graduated in 0.2 inches of mercury was connected to the nozzle

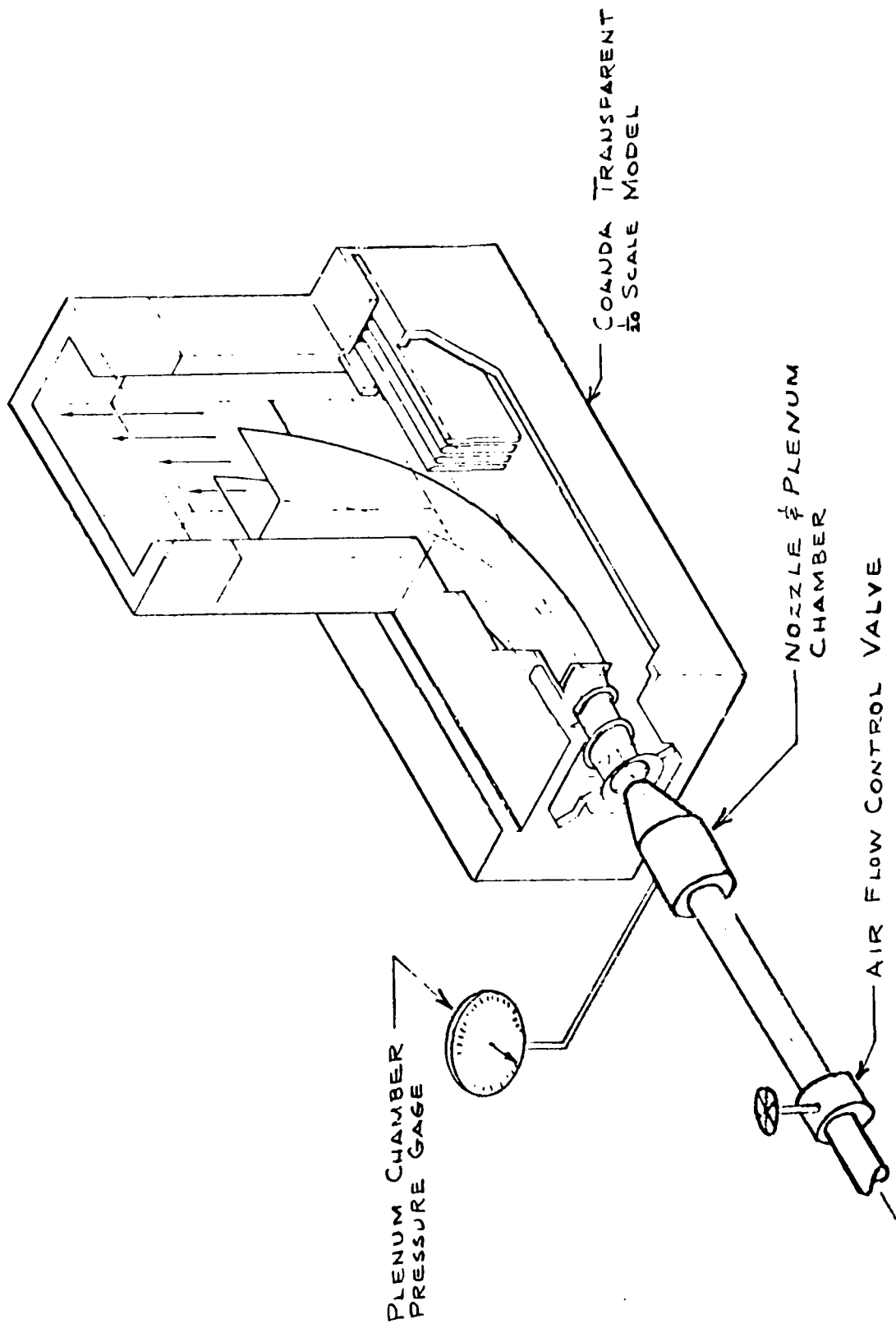

FIGURE 1, THREE-DIMENSIONAL COANDA MODEL TEST SET UP

plenum manifold. The model and air systems were checked for proper operation and safety as the plenum pressure was incrementally increased to slightly more than the design pressure ratio of 2.22 plenum total pressure-to-ambient pressure. A hand-held meter was used to read noise levels in dBA around the model and air control valve.

The smoke generators used a colored oil-soluble aniline dye in a paraffin base. A heater coil in the bottom of each crucible was covered with the dye and electrically connected to power through a rheostat control to regulate smoke generation.

A four-inch string tuft was attached to a 12-inch stiff wire wand for use in surveying areas of interest.

The model and nozzle plenum were visually aligned along the centerlines and spaced 0.48 inch longitudinally to agree with the scale.

5.2 Functional Demonstration Test

Ambient pressure at the beginning of the test was 28.538" Hg. For air at moderate temperatures, choked flow should exist at all pressure ratios above 1.892 corresponding to pressures above 25.48" Hg gauge. Gauge pressure at the design PR of 2.22 was 34.82" Hg.

Checkout runs were made to verify proper operation of the model and to adjust the flow visualization devices at plenum chamber pressure ratios (PCPR) of up to 1.91. Airflow was then gradually increased until the PCPR stabilized at 2.226. All flow visualization devices were observed and noted, dBA noise levels were measured. The smoke devices were operated at full capacity. A yellow smoke generator underneath the ejectors and a blue smoke generator near the nozzle exit were moved to the rear of the enclosure floor and along

the secondary inlets, respectively, and then removed entirely after failure to provide meaningful results. The wand tuft was used to survey the area around the entire enclosure and some of the areas inside the side inlets.

5.3 Assessment of Functional Demonstration

The following assessments and conclusions are based on three demonstration test runs of 5 to 10 minutes duration:

- Controls and Instrumentation

Airflow was easily controlled to the desired plenum pressure and remained steady.

- Transparency and Visibility

Visibility of the flow area is estimated at 95 percent, constrained only by the metal ejectors and supports. Use of a different type plexiglas material for the acoustic panels does not unduly compromise visibility.

- Coanda Operation

Primary airflow adhered to the Coanda at all flow rates, with and without the enclosure installed. There was no attempt to build structural dynamic similarity into the model. However, minor sidewall vibrations similar to those noted in high speed movies of the demonstrator were noted at rated nozzle pressure ratio.

- Ejectors

The three-stage metal ejector assembly taken from a display model appeared to perform satisfactorily in all

respects. It is noted that the ejector support legs are longitudinally wider than accurate scale model sizing would permit.

- Enclosure and Stack

The enclosure, stack, and the acoustic inlet panels appeared to be accurately constructed and performed as expected. Except for the enclosure tie-down bolts, all attachments provided quick efficient access to inside components. Minor air leakage existed underneath the enclosure walls but sealing the interface is undesirable and probably unnecessary. Minor vibrations of the walls, roof, and stack occurred.

- Flow Visualization Techniques

The most effective flow indicators were the string tufts. The volume of smoke generated at full smoke capacity was inadequate. Smoke indicators are desirable but must be greatly improved to be of value.

The tufted wand was very useful. With the wand, it was possible to trace the cooling airflow path in almost any area. It was especially useful in tracing the path of cooling air through the side entrances to the ejectors and along the Coanda open channel.

- Flow Fields

The flow fields are illustrated on Figures 2, 3, and 4. The Figure 2 summary illustrates the primary flow representative of hot exhaust gases and the cooling air

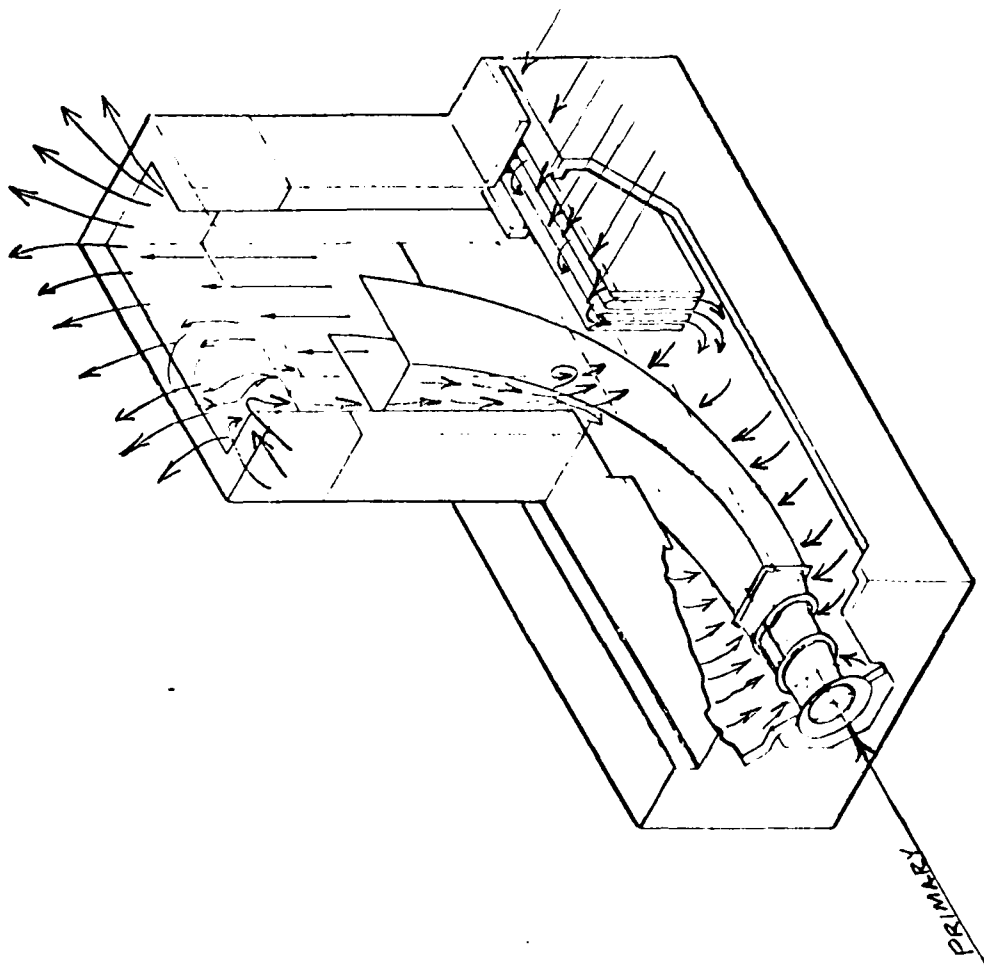

FIGURE 2, FLOW FIELD SUMMARY

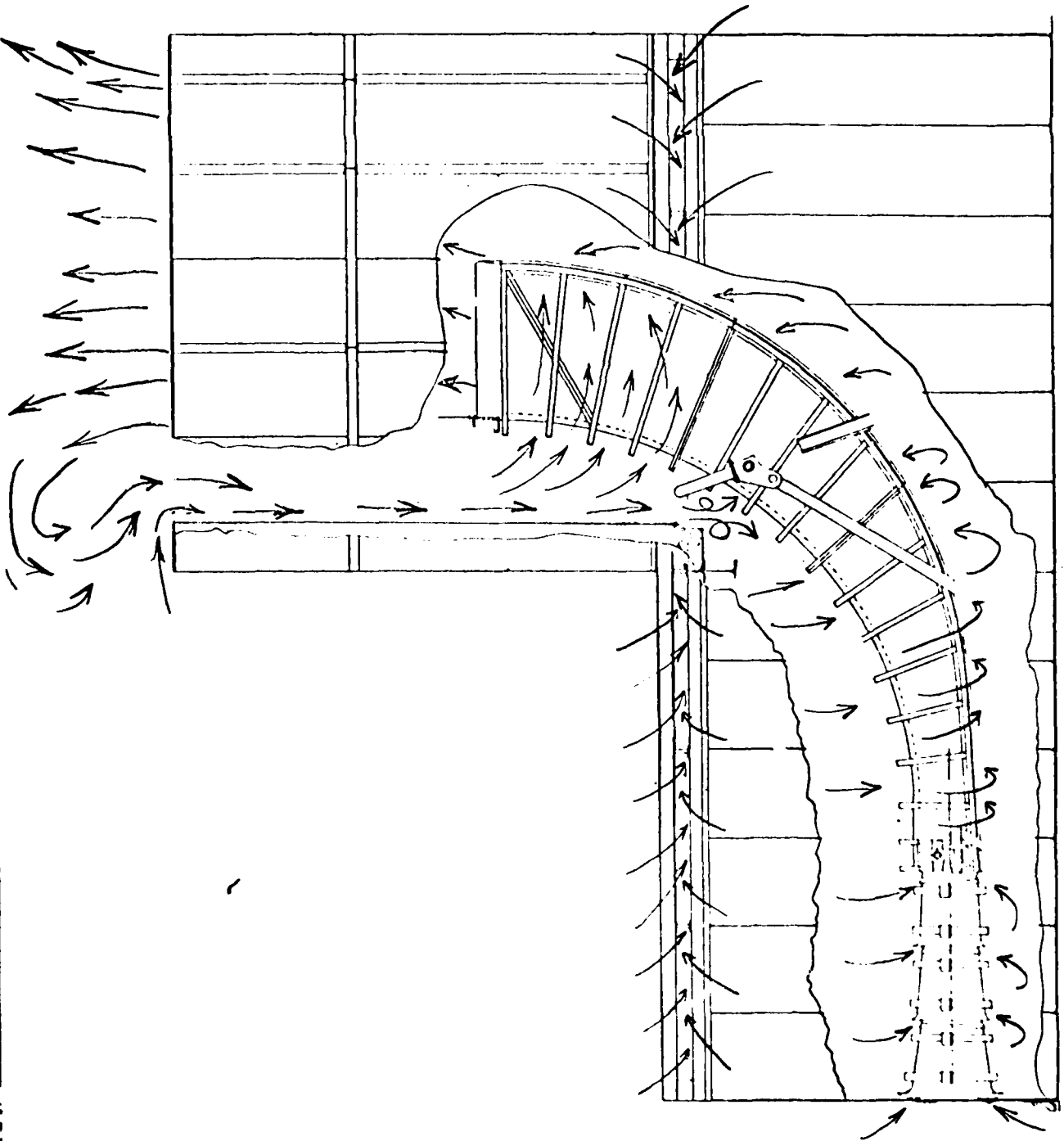

FIGURE 3, FLOW FIELD SIDE VIEW

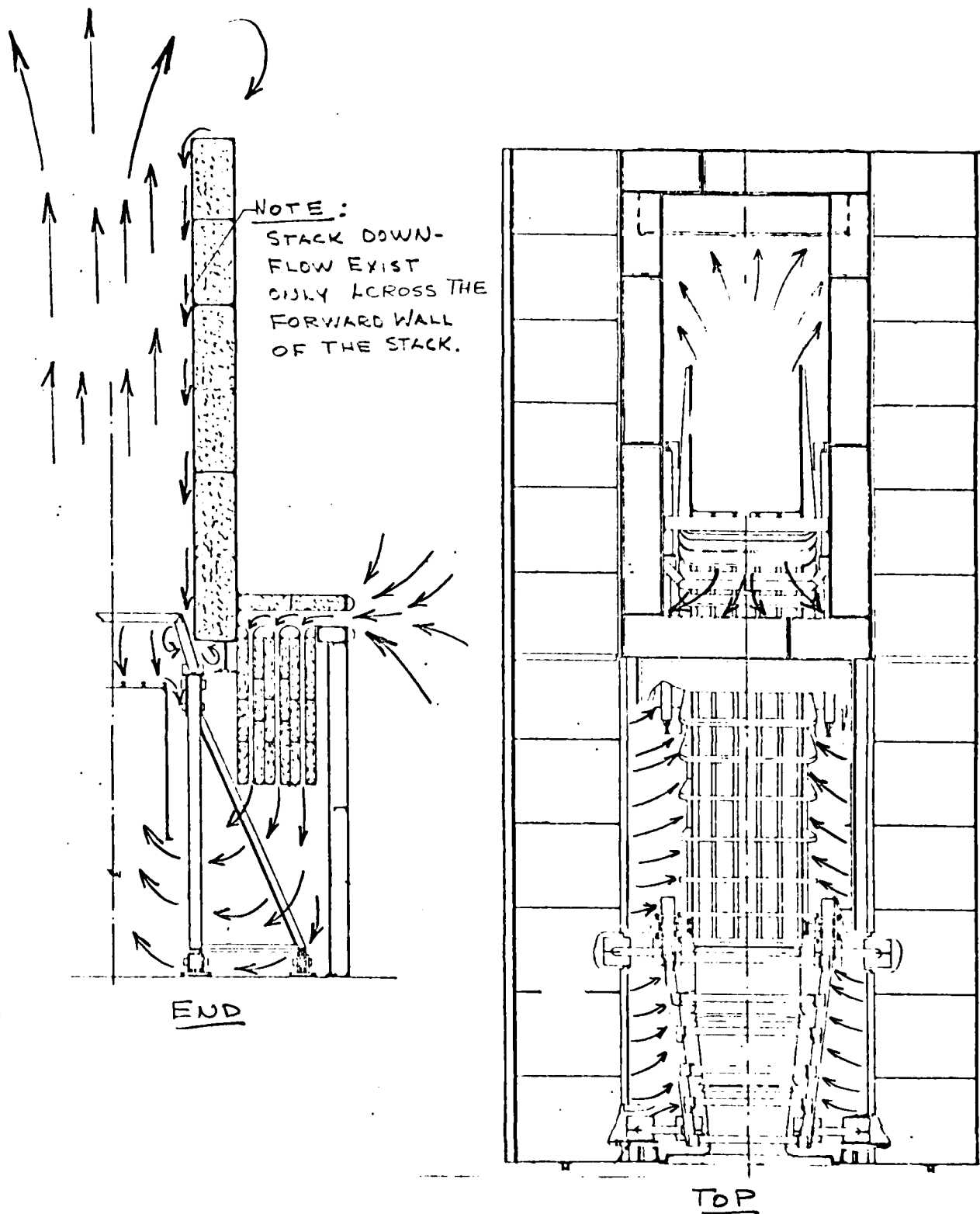

FIGURE 4, FLOW FIELD END & TOP VIEWS

entering through the side air inlets turning downward between the acoustic inlet panels then inward toward the Coanda and ejectors. The cooled primary flow fills the Coanda and expands to the back and sidewalls of the stack but not completely to the stack forward wall. At approximately 2 model inches (3 feet full scale) above the stack, the forward primary flow stream turns forward and downward, reversing its direction and reentering the stack across the complete width of the forward wall. The recirculating downflow bifurcates around the Coanda at the base of the stack where turbulence and vortexing occurs. The flow then moves forward and downward and reenters the Coanda flow.

Figure 3 illustrates the flow as seen from the sides. In general, flow entering the forward side inlets proceeds directly to the nearest entry point in the ejectors or Coanda, as applicable. The model induces a considerable amount of secondary airflow and is expected to produce enclosure pressure depressions comparable to those measured on the full scale demonstrator.

Figure 4 further illustrates the information discussed above. Recirculation illustrated in the end view is believed to exist only at the forward wall.

Noise levels around the model and operator's air control valve read 114 to 115 dBA on the hand-held meter. A peak of 130 dBA was indicated at the nozzle exit.

6.0 PLANNED APPLICATION OF RESULTS

The model has the potential of being an effective and inexpensive aerodynamic tool which may be used to:

- Test and compare configuration changes.
- Quantify flow field geometries.
- Develop and verify computer programs related to the modeled flow systems.
- Provide flow visualization throughout the ground noise suppressor model system.

6.1 Analytical Analyses

Analytical studies of the physics of Coanda and staged ejector flows were conducted in the past (Reference 1). The results of these studies produced computer codings which are useful for the prediction of ejector and Coanda flow parameters. Figure 5 presents a predicted Coanda Mach number exit profile evaluated from the two programs with experimental arena model data. The agreement with the simulated TF30 at afterburning is quite good, both in the mixing region and the boundary layer region; however, a comparison to the TF30 at MRT was considerably more "peaky" than the relatively flat MRT experimental profile.

The analytical methods upon which the computer coding was based consists of a solution of the conservation of moment of momentum equations outside of the boundary layer including wall drag effects and a simplified radial momentum solution with an assumed hyperbolic secant flow momentum profile. The boundary layer solution is based on the moment of momentum integral method with a 1/7 power law boundary layer profile assumption (Pechau method).

The wall drag in the moment of momentum equation had to be increased three-fold over flat plate drag to achieve the agreement shown by Figure 5.

The theoretical entrainment coefficients of 1.5 for the TF30 after-burning condition and 1.12 for the TF30 MRT condition is considerably lower than an assumed value of 2.0 used in test cell proposal efforts. If the lower entrainment coefficients could be verified on the transparent Coanda model, the secondary inlet areas for full scale Coanda suppressors could be reduced significantly.

The ejector and Coanda computer codings were applied to the 1/20th scale model subject to the conditions shown in Table 1. The results are shown by Figure 6 in comparison to measured full scale J57-P-21 data. The agreement is fair; however, it must be pointed out that boundary layers do not scale well and it is assumed that Coanda flows don't either. This means that the 1/20th scale analysis could be compared to experimental 1/20th scale model data to establish the relationship of the analytical techniques and actual test results.

6.2 Correlation of Scale Model Data to Full Scale Design

Correlation between 1/20th scale model test data and the ejector and Coanda analytical tools was planned for a variety of flow conditions. These computer codings could then be used to predict full scale design requirements with a high confidence level. Completion of Phases 2 and 3 of the 1/20th scale model program would be required to achieve this capability.

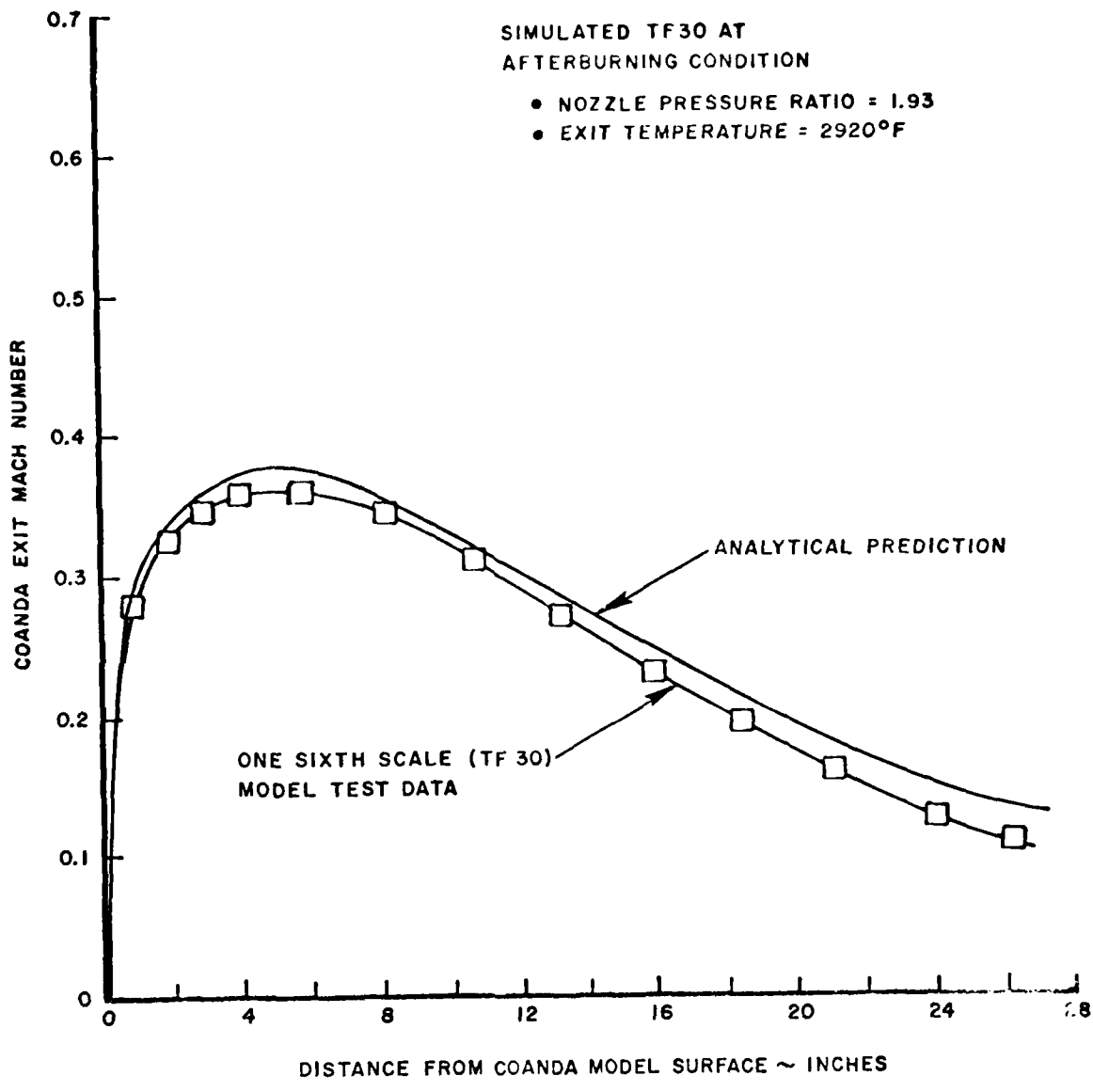

FIGURE 5. COMPARISON OF COANDA THEORY TO ARENA MODEL TEST DATA

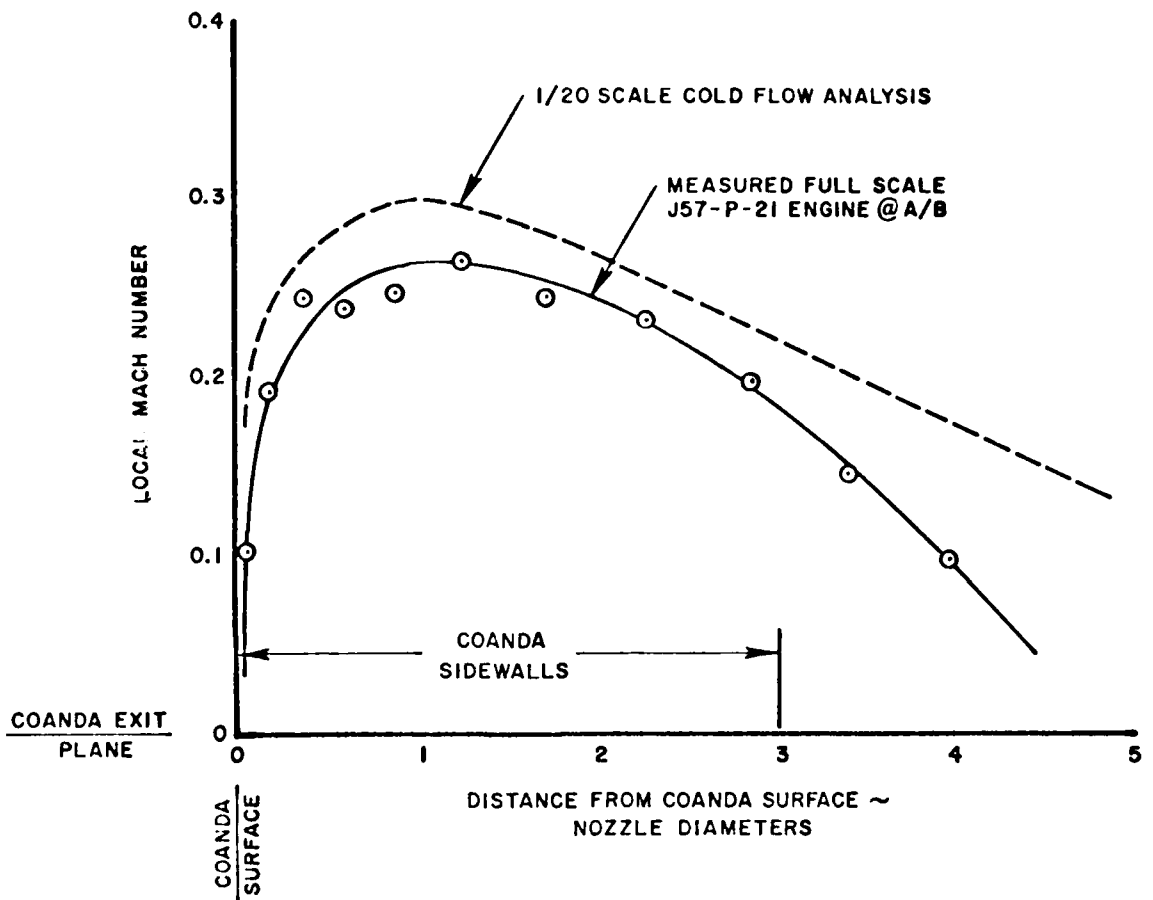

FIGURE 6. COANDA EXIT MACH NUMBER PROFILES

7.0 CONCLUSIONS

Based on a cursory functional demonstration test, the following conclusions were made:

- The model accurately represents the full scale flow field.
- The model vividly illustrates recirculation of primary flow that was circumstantially evident on the full scale demonstrator tests.

REFERENCES

1. "Feasibility and Initial Model Studies of a Coanda/Refraction Type Noise Suppressor System," Technical Report No. D3-9068, January 1973.

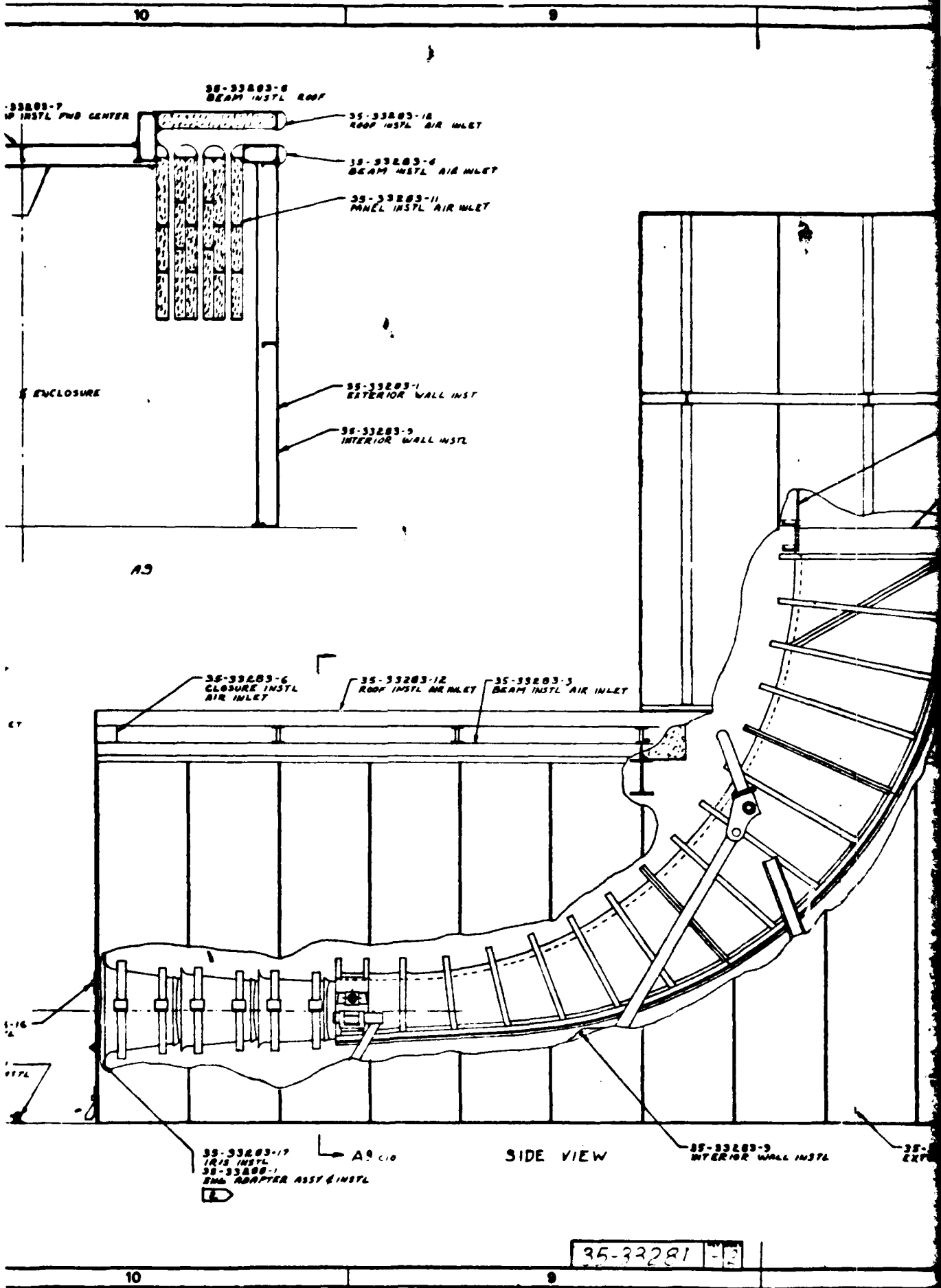

32-335815

12

11

35-33283-10
STACK INSTL

C

35-33283-14
STACK INSTL UPPER

35-33283-4
STACK INSTL LOWER

35-33283-7
ROOF INSTL FWD CENTER

35-33283-5
BEAM INSTL ROOF

35-33283-12
ROOF INSTL AIR INLET

35-33283-6
CLOSURE INSTL AIR INLET

35-33283-3
BEAM INSTL AIR INLET

35-33300-10
PANEL ASSY FWD
35-33301-10
35-33301-11
35-33301-12
PANEL ASSY INNER FWD

35-33300-7
PANEL ASSY FWD
35-33301-503
PANEL ASSY INNER FWD

35-33280-1
EXTERIOR WALL INSTL

35-33300-8
PANEL ASSY FWD
35-33301-26
PANEL ASSY INNER FWD

35-33280
DOOR INSTL

35-33309
DOOR STOP

35-33283-16
DOOR INSTL

35-33309-1
DOOR STOP INSTL

-3 INSTL
FRONT VIEW

35-33283-17
IRIS INSTL
35-33280-1
ENG ADAPTER ASSY INSTL

35-33300-11
PANEL ASSY FWD
35-33301-13
PANEL ASSY INNER FWD

12

11

11/6

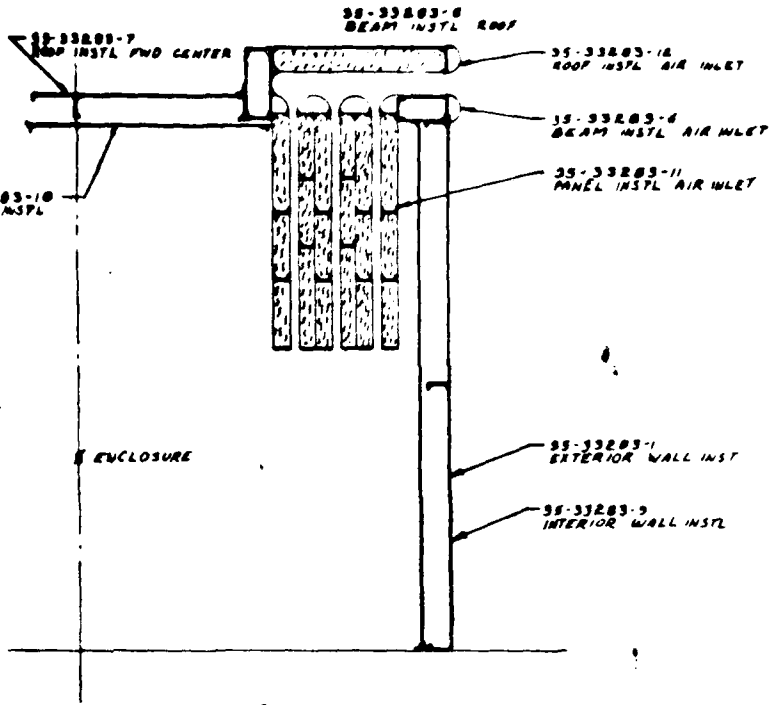

2-19
UPPER

2-9
LOWER

A9

- 35-33283-12
ROOF INSTL AIR INLET
- 35-33283-6
CLOSURE INSTL AIR INLET
- 35-33283-3
BEAM INSTL AIR INLET
- 35-33283-1
EXTERIOR WALL INSTL
- 35-33283-0
PANEL INSTL FWD
35-33283-10
PANEL INSTL INNER FWD
- 35-33283-16
DOOR INSTL
- 35-33283-1
DOOR STOP INSTL
- 35-33283-16
DOOR INSTL

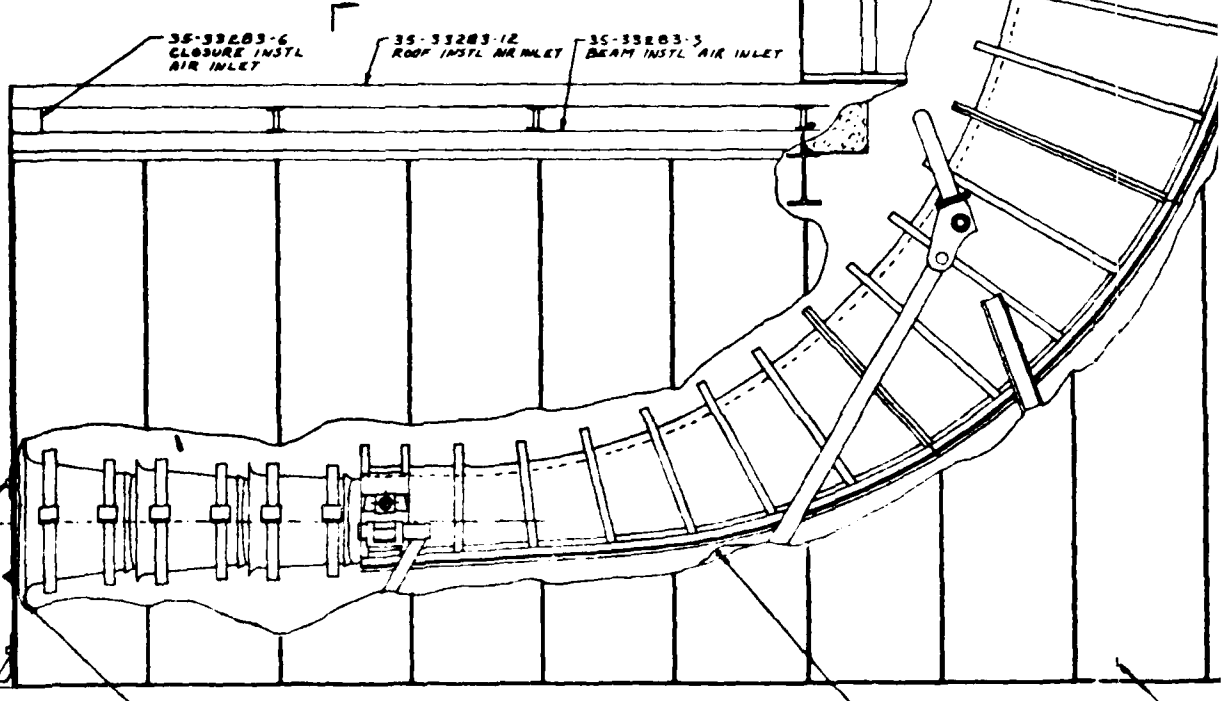

SIDE VIEW

35-33283-17
IRIS INSTL

35-33283-1
EMB ADAPTER ASSY INSTL

A9

35-33281

Handwritten mark resembling a stylized '4' or '9'.

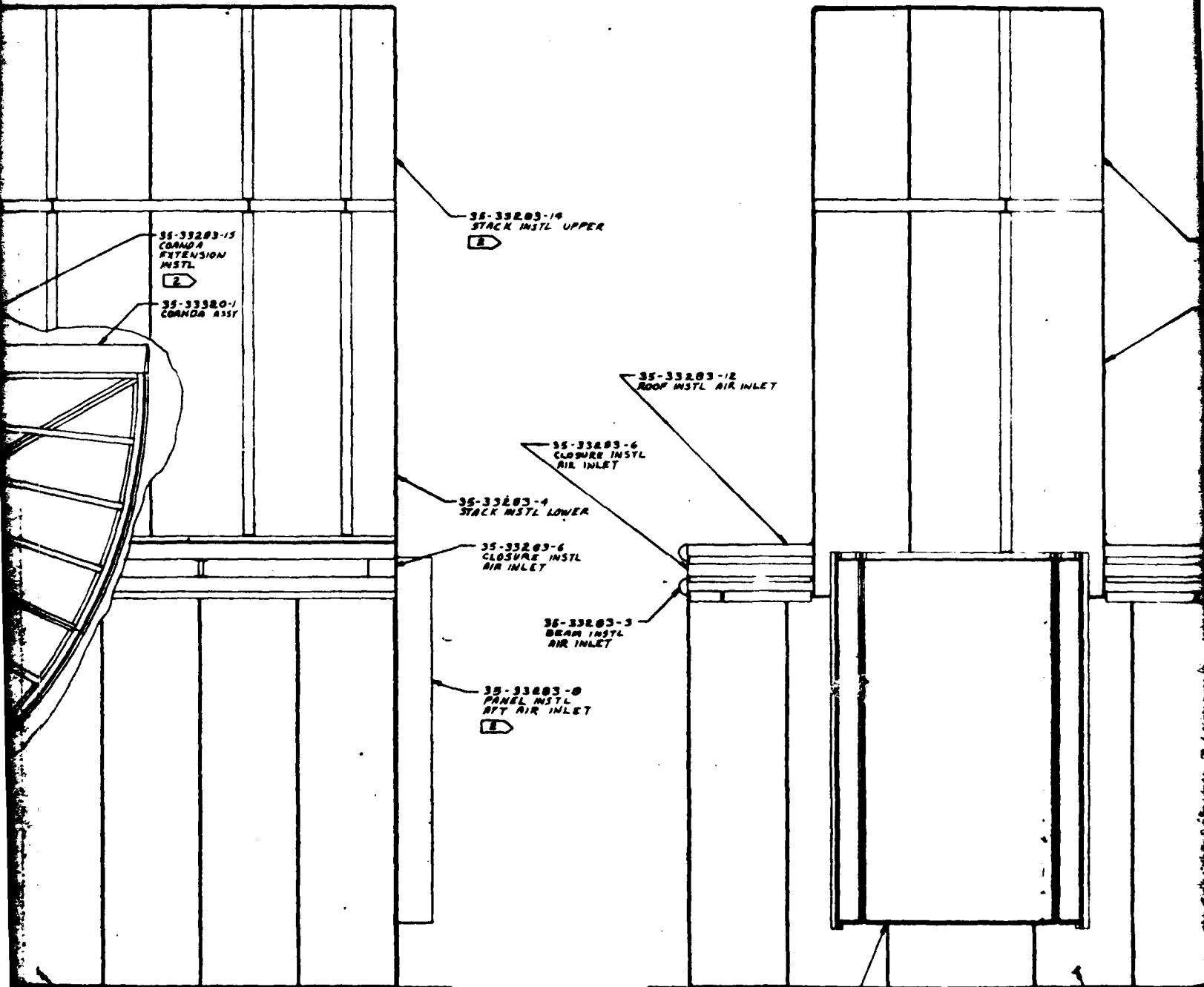

REAR VIEW

3

35-33283-14
STACK INSTL UPPER

E

35-33283-9
STACK INSTL LOWER

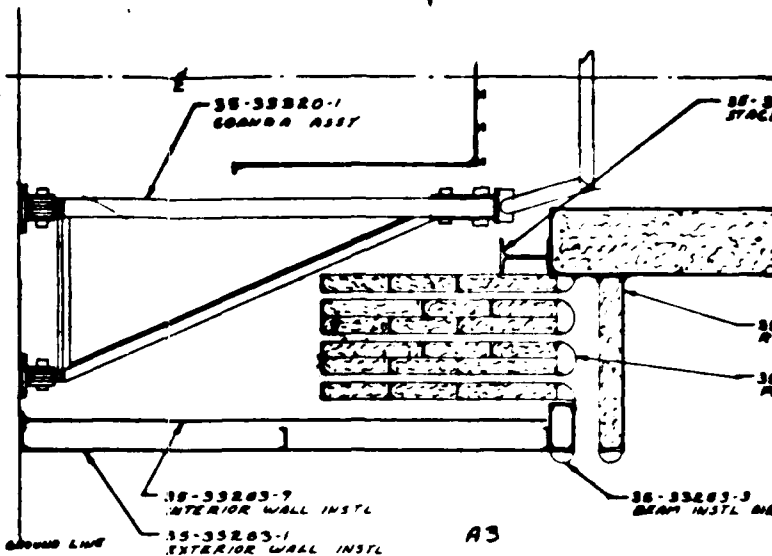

35-33300-7
35-33300-8
35-33300-9
35-33300-10
35-33300-11
35-33300-12
35-33300-13
35-33300-14
35-33300-15
35-33300-16
35-33300-17
35-33300-18
35-33300-19
35-33300-20
35-33300-21
35-33300-22
35-33300-23
35-33300-24
35-33300-25
35-33300-26
35-33300-27
35-33300-28
35-33300-29
35-33300-30
35-33300-31
35-33300-32
35-33300-33
35-33300-34
35-33300-35
35-33300-36
35-33300-37
35-33300-38
35-33300-39
35-33300-40
35-33300-41
35-33300-42
35-33300-43
35-33300-44
35-33300-45
35-33300-46
35-33300-47
35-33300-48
35-33300-49
35-33300-50

I

PANEL ASSY FWD
USED IN -4 ASSY

PANEL ASSY INNER FWD
USED IN -4 ASSY

I

35-33283-17
IRIS INSTL
35-33283-1
DUG ADAPTER ASSY INSTL

35-33309-1
DOOR STOP INSTL

35-33283-16
DOOR INSTL

35-33283-10
CEILING INSTL

35-33283-7
ROOF INSTL FWD CENTER

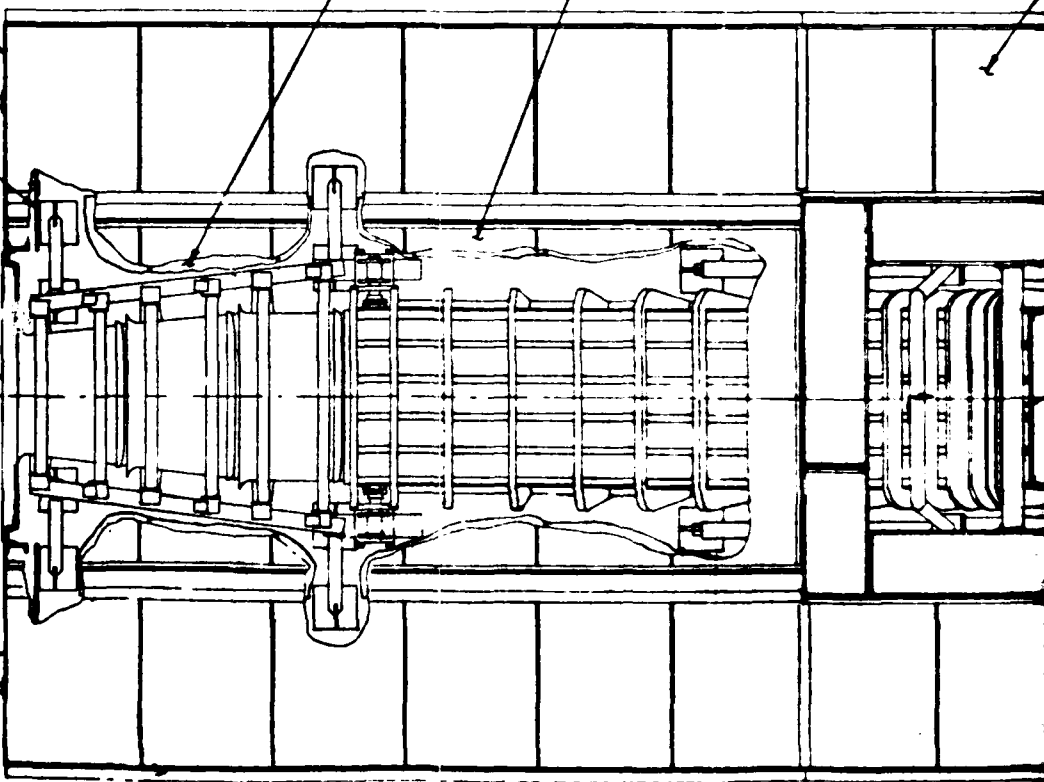

35-33283-1
INTERIOR WALL INSTL

PLAN VIEW

35-33281

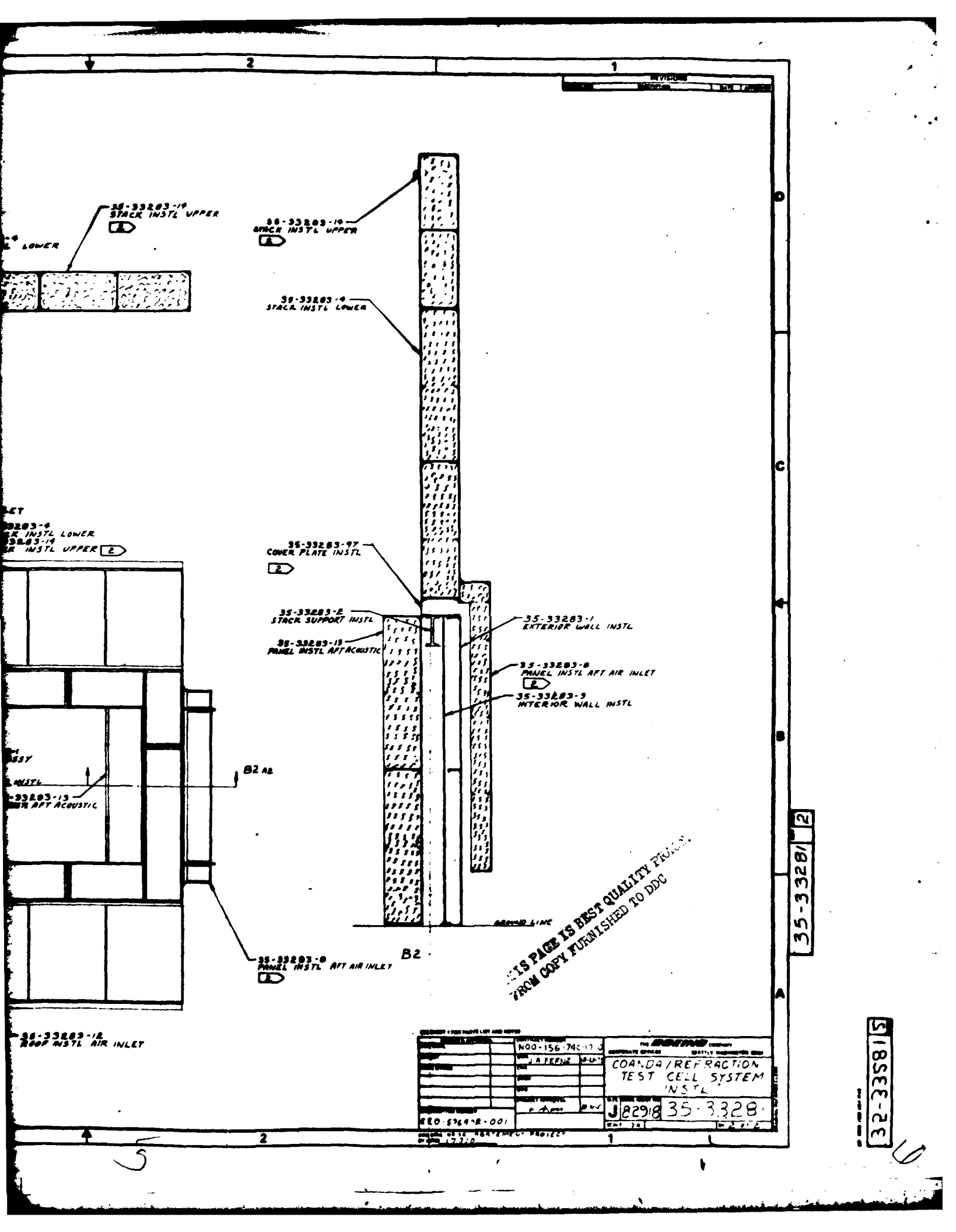

**THIS PAGE IS BEST QUALITY FROM
FROM COPY FURNISHED TO DDC**

35-33281-2

32-335815

<small>REVISIONS</small> NO. 1 DATE 12-17-70		<small>REVISIONS</small> NO. 1 DATE 12-17-70	
<small>PROJECT</small> 280-57642-001	<small>SERVICE NUMBER</small> HQG-156-742-17	<small>THE COANDA COMPANY</small> CORPORATE OFFICE SEATTLE WASHINGTON 98101	<small>PROJECT NUMBER</small> 35-33281
<small>DESIGNED BY</small> J. A. GREEN	<small>CHECKED BY</small> J. A. GREEN	<small>COANDA/REFRACTION TEST CELL SYSTEM INSTL</small>	<small>DATE</small> 12-17-70
<small>PROJECT NUMBER</small> 280-57642-001	<small>DATE</small> 12-17-70	<small>PROJECT NUMBER</small> 35-33281	<small>DATE</small> 12-17-70

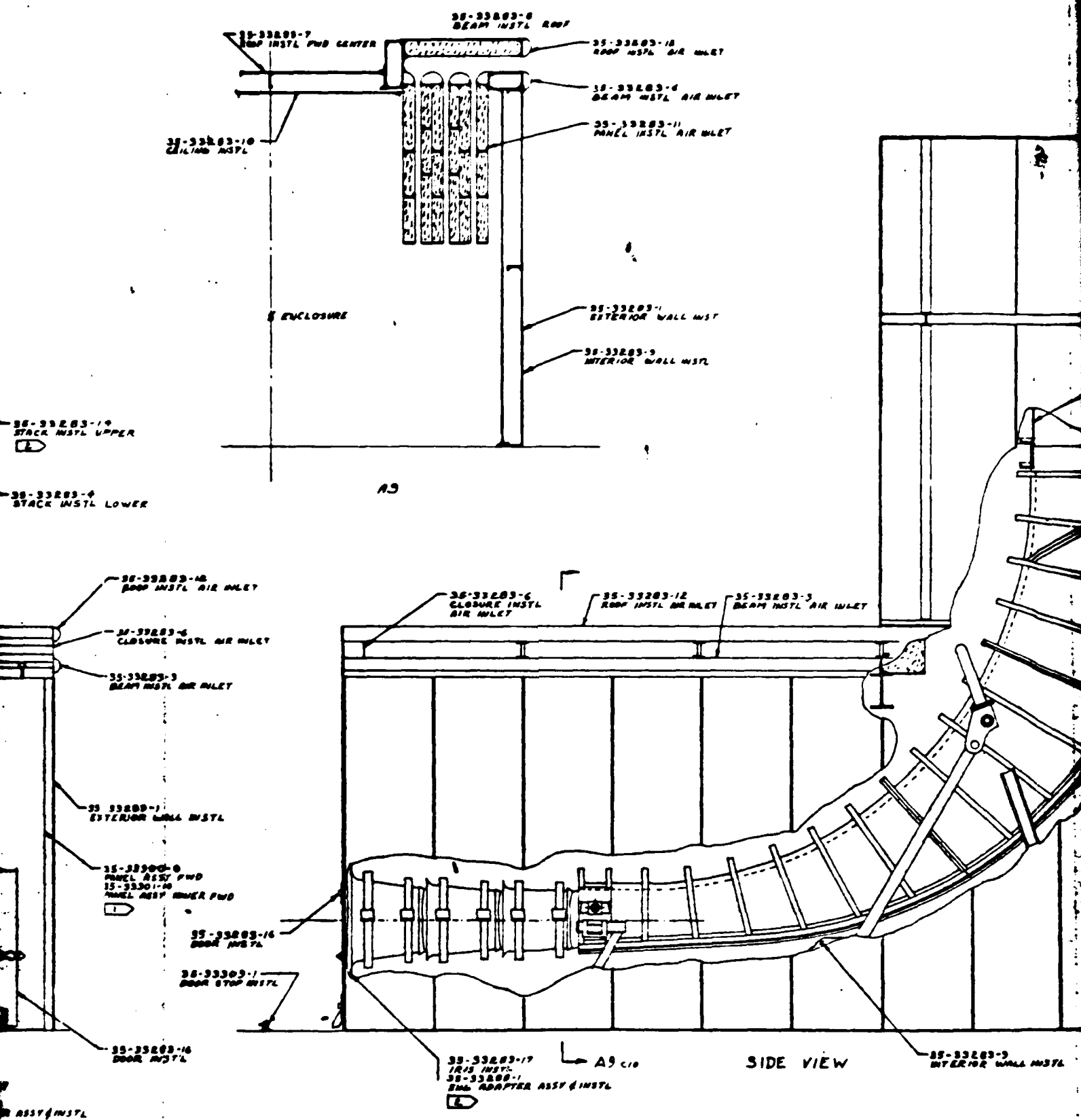

ASSY INSTL
FWD
INNER FWD

35-33281 -2

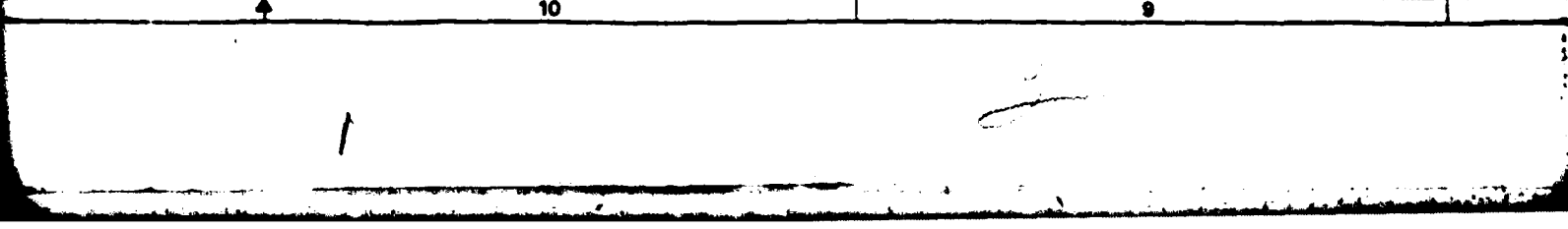

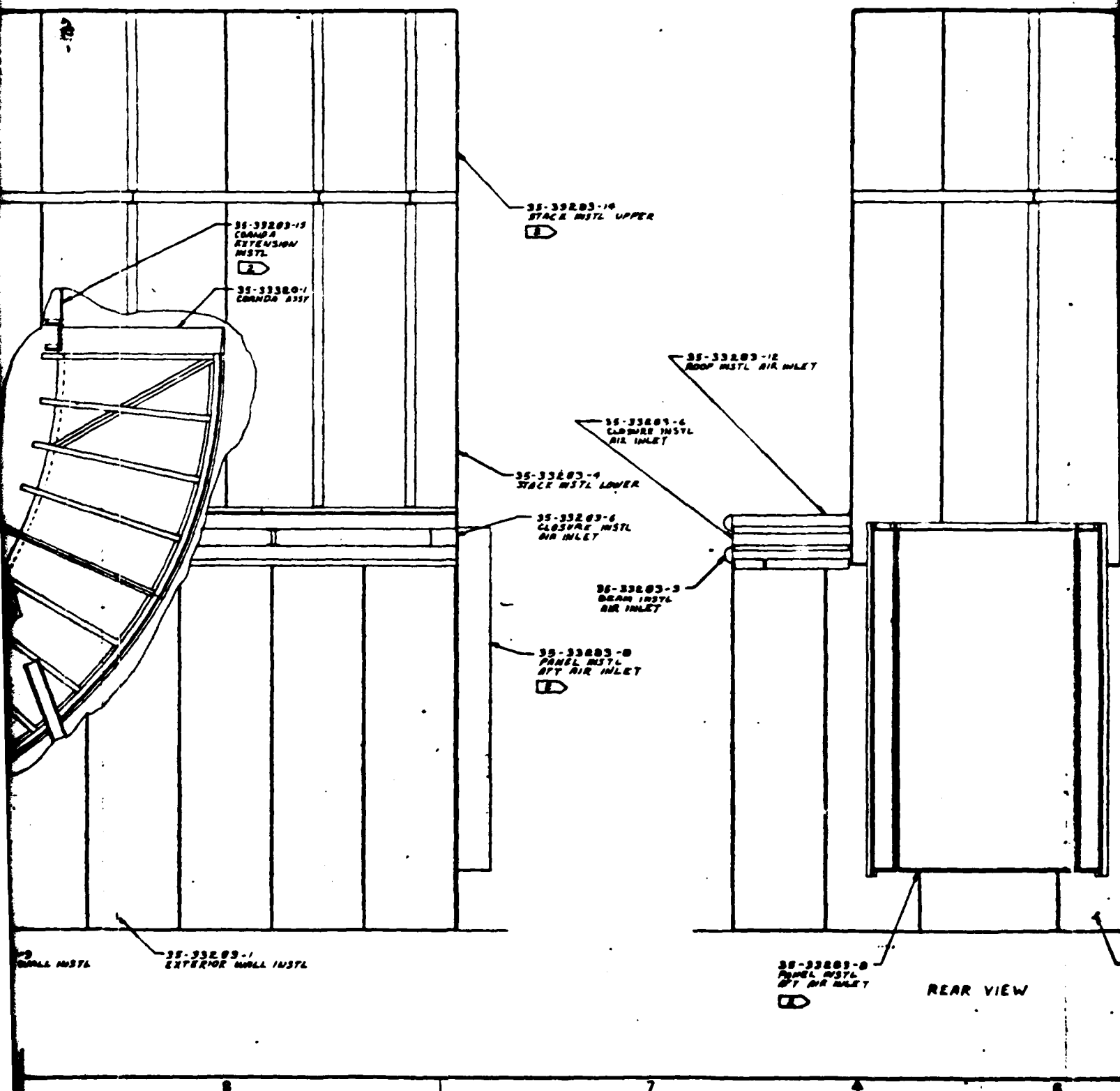

35-3283-15
COMMAND
EXTENSION
INSTL
2

35-3280-1
COMMAND ASSY

35-3283-14
STACK INSTL UPPER
1

35-3283-12
ROOF INSTL AIR INLET

35-3283-6
CLOSURE INSTL
AIR INLET

35-3283-4
STACK INSTL LOWER

35-3283-6
CLOSURE INSTL
AIR INLET

35-3283-3
DRAIN INSTL
AIR INLET

35-3283-8
PANEL INSTL
RTT AIR INLET
1

35-3283-1
SMALL INSTL

35-3283-1
EXTERIOR WALL INSTL

35-3283-8
PANEL INSTL
RTT AIR INLET
1

REAR VIEW

1

2

3

4

5

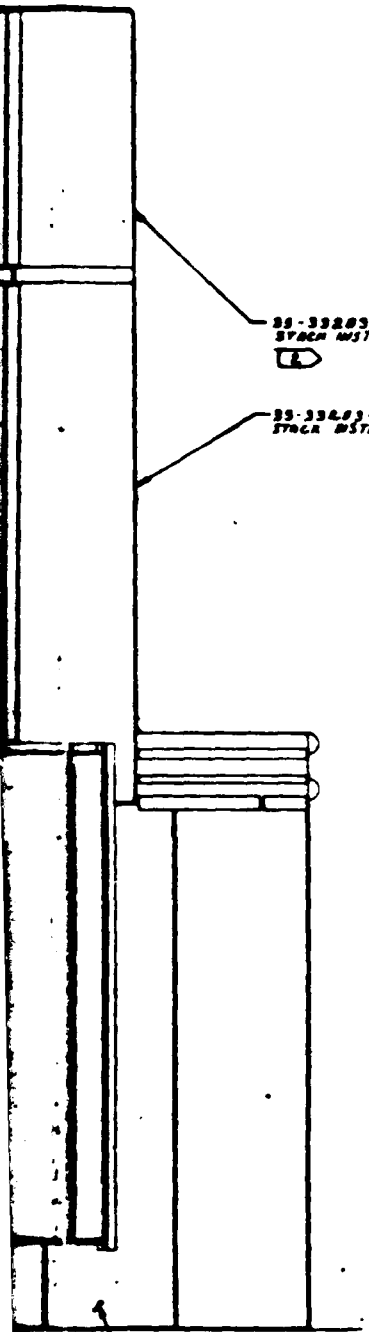

35-33283-14
STOCH INSTL UPPER

35-33283-9
STOCH INSTL LOWER

35-33300-7
35-33300-8
35-33300-10
35-33300-11
35-33300-12
35-33300-13
35-33300-19
35-33300-503
PANEL ASSY INNER PWD
USED IN -4 ASSY

35-33301-10
35-33301-11
35-33301-12
35-33301-13
35-33301-19
35-33301-503
PANEL ASSY INNER PWD
USED IN -4 ASSY

35-33283-17
IRIS INSTL
DOL DRAPPER ASSY (INSTL)

35-33309-1
DOOR STOP INSTL

35-33283-16
DOOR INSTL

35-33283-1
EXTERIOR WALL INSTL

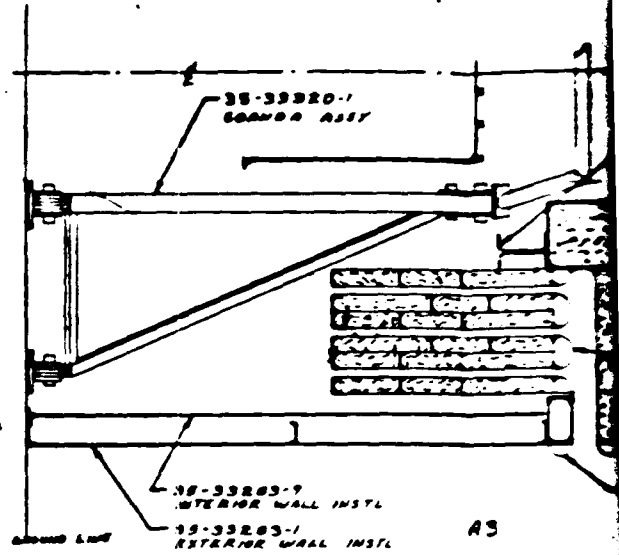

35-33280-1
CORNER ASSY

35-33283-9
INTERIOR WALL INSTL

35-33283-1
EXTERIOR WALL INSTL

A3

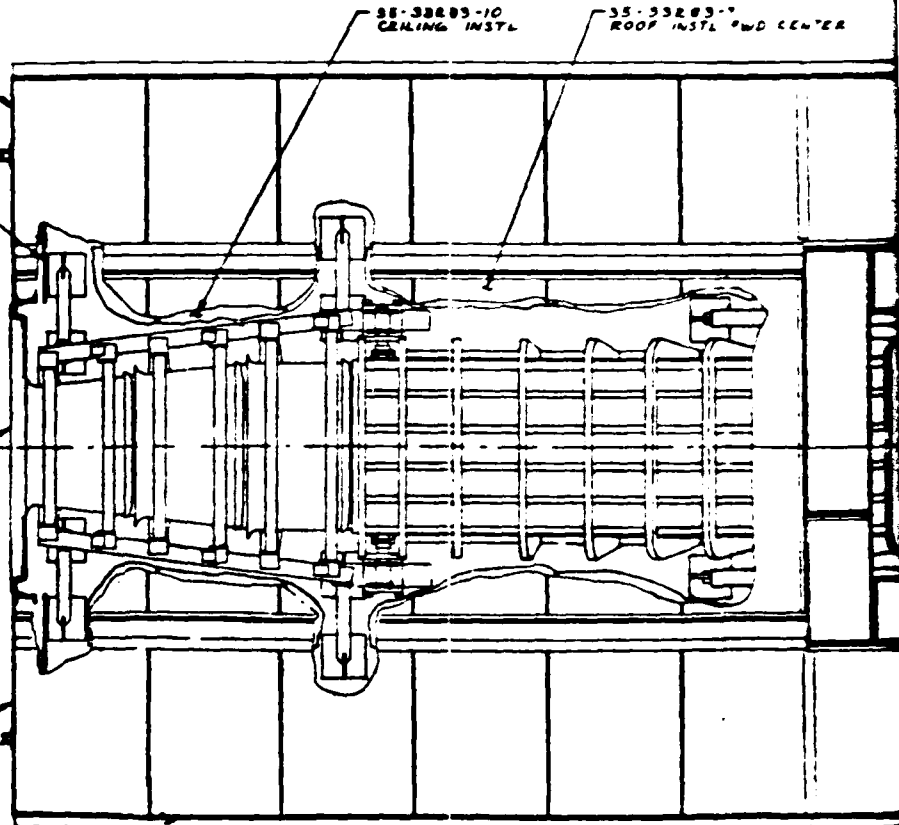

35-33283-10
CEILING INSTL

35-33283-11
ROOF INSTL PWD CENTER

PLAN VIEW

35-33281 2

6

4

4

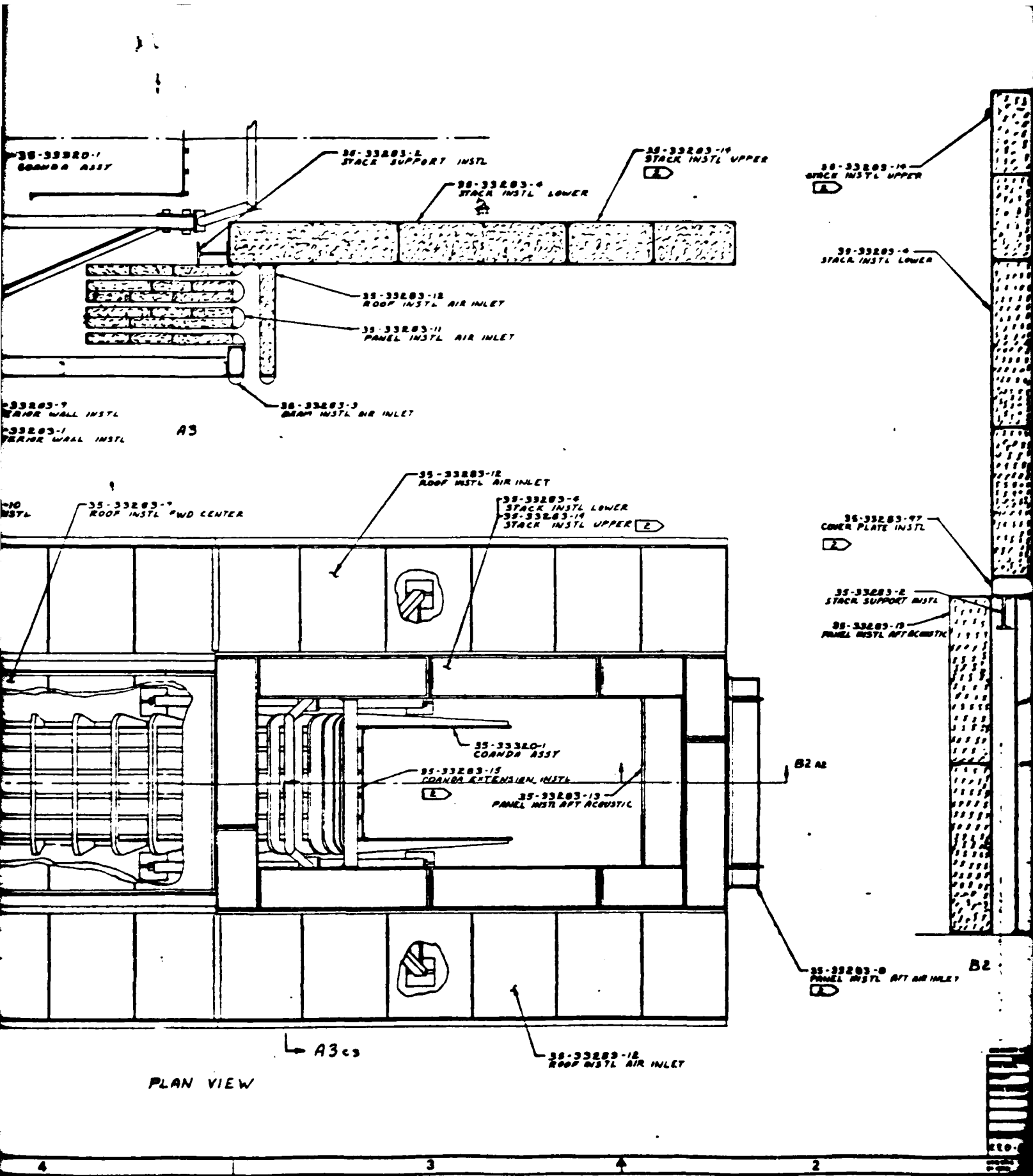

PLAN VIEW

5

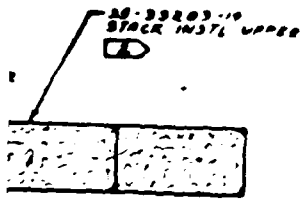

35-33203-19
STACK INSTL UPPER

35-33203-4
STACK INSTL LOWER

35-33203-97
COVER PLATE INSTL

35-33203-2
STACK SUPPORT INSTL

35-33203-15
PANEL INSTL OPT ACOUSTIC

35-33203-1
EXTERIOR WALL INSTL

35-33203-8
PANEL INSTL OPT AIR INLET

35-33203-3
INTERIOR WALL INSTL

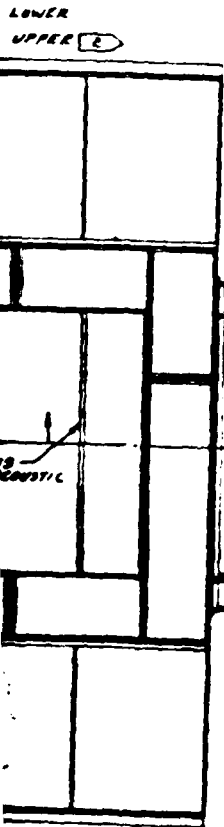

35-33203-0
PANEL INSTL OPT AIR INLET

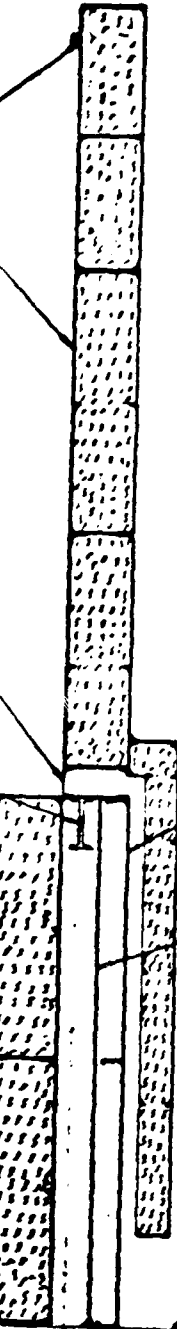

35-33201/2

35-12
1 1/2 AIR INLET

PROJECT NO.	100-156-7407-0	THE BURNS COMPANY
DATE	1 FEB 72	BATTLE PASADENA, CALIF.
DESCRIPTION	COANDA/REFRACTION TEST CELL SYSTEM INSTL	
PROJECT NO.	100-156-7407-00	J22918 35-3320
DATE		

32-335815

6

APPENDIX A

MODEL PHOTOGRAPH

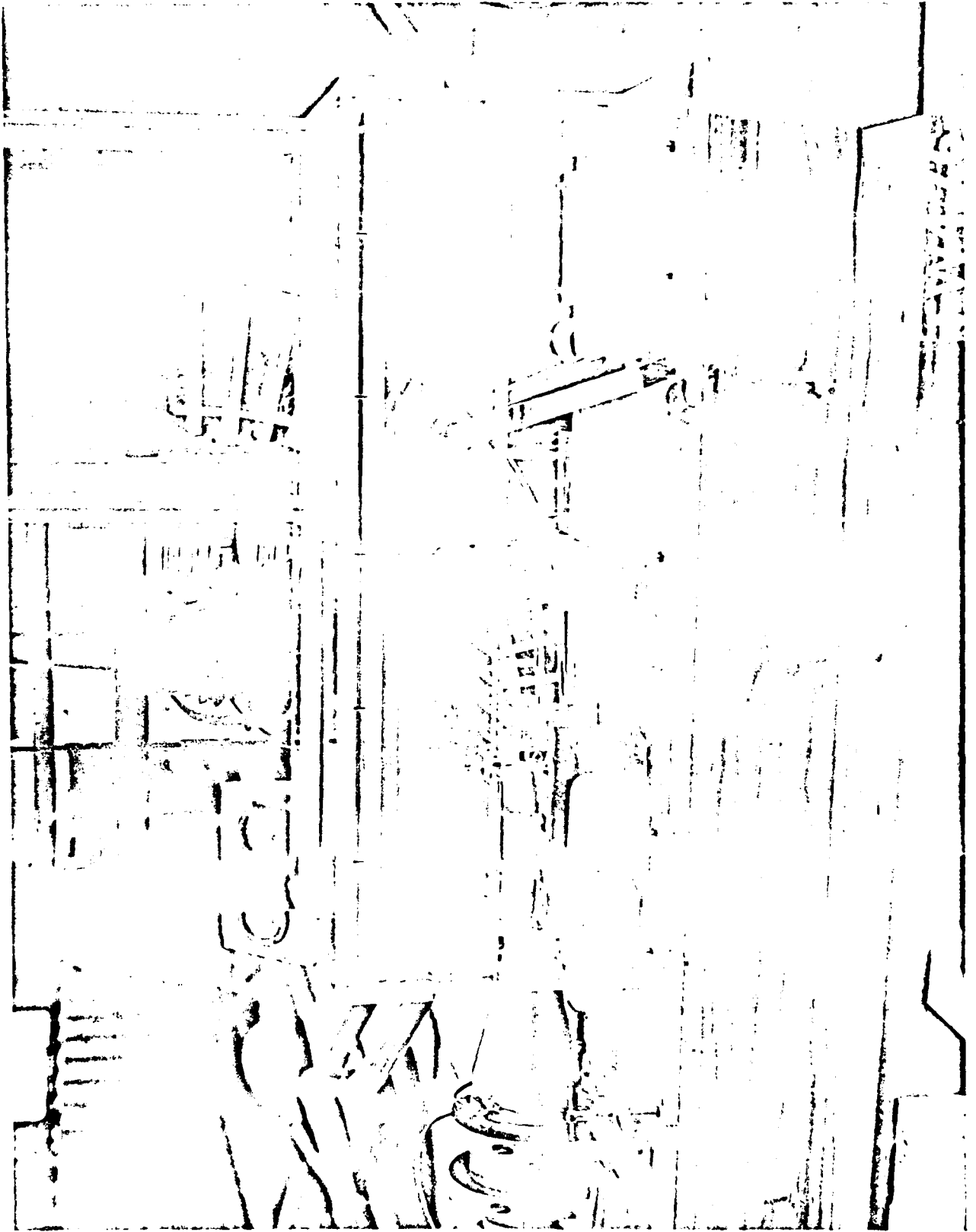

APPENDIX B

MODEL DRAWING

FILMED

2-8/11