

AD-A107 676

TRW DEFENSE AND SPACE SYSTEMS GROUP REDONDO BEACH CA --ETC F/6 10/2
TWO POINT FOUR KW DC/DC CONVERTER REGULATOR. (U)
OCT 81 R E EGGERT

DAAB07-78-C-2988

UNCLASSIFIED

DELET-TR-78-2988-F

NL

of 2
ADA
107676

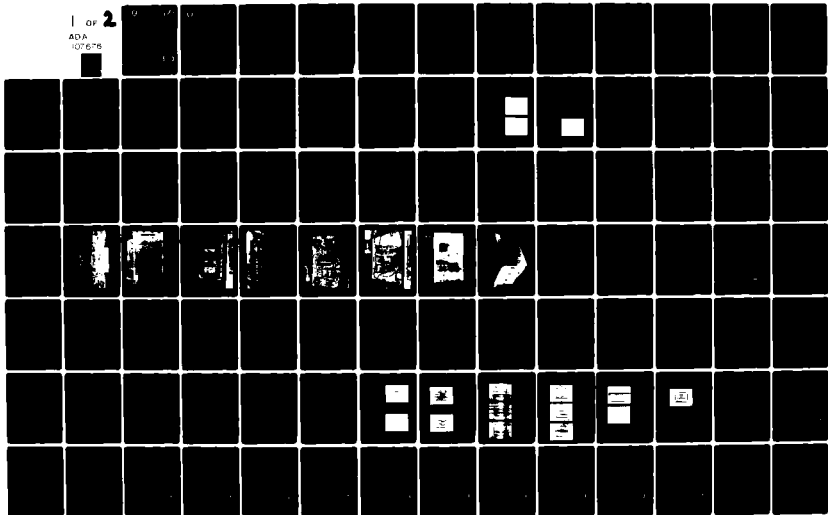

LEVEL

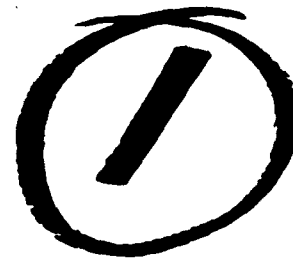

Research and Development Technical Report

DELET-TR-78-2988-F

AD A I U : 0 0 0

TWO POINT FOUR KW DC/DC CONVERTER REGULATOR

R.E. Eggert
TRW Defense & Space Systems Group
Power Conversion Electronics Department
Redondo Beach, CA 90278

October 1981

Final Report for Period October 1978 to October 1981

DISTRIBUTION STATEMENT

Approved for public release;
distribution unlimited.

Prepared for:
ELECTRONICS TECHNOLOGY & DEVICES LABORATORY

DTIC
ELECTE
NOV 23 1981
S D D

DTIC FILE COPY

ERADCOM

US ARMY ELECTRONICS RESEARCH AND DEVELOPMENT COMMAND
FORT MONMOUTH, NEW JERSEY 07703

81 11 20 106

HISA-FM 195-78



Research and Development Technical Report

DELET-TR-78-2988-F

TWO POINT FOUR KW DC/DC CONVERTER REGULATOR

R.E. Eggert
TRW Defense & Space Systems Group
Power Conversion Electronics Department
Redondo Beach, CA 90278

October 1981

Final Report for Period October 1978 to October 1981

DISTRIBUTION STATEMENT

Approved for public release;
distribution unlimited.

Prepared for:
ELECTRONICS TECHNOLOGY & DEVICES LABORATORY

Accession For	
NTIS GRA&I	<input checked="" type="checkbox"/>
DTIC TAB	<input type="checkbox"/>
Unannounced	<input type="checkbox"/>
Justification	
By _____	
Distribution/ _____	
Availability Codes	
Dist	Avail and/or Special
A	

ERADCOM

US ARMY ELECTRONICS RESEARCH AND DEVELOPMENT COMMAND
FORT MONMOUTH, NEW JERSEY 07703

410430

UNCLASSIFIED

SECURITY CLASSIFICATION OF THIS PAGE (When Data Entered)

REPORT DOCUMENTATION PAGE		READ INSTRUCTIONS BEFORE COMPLETING FORM
1. REPORT NUMBER DELET-TR-78-2988-F	2. GOVT ACCESSION NO. AD-A 207	3. RECIPIENT'S CATALOG NUMBER 276
4. TITLE (and Subtitle) TWO POINT FOUR KW DC/DC CONVERTER REGULATOR	5. TYPE OF REPORT & PERIOD COVERED FINAL REPORT October 1978 to April 1981	
	6. PERFORMING ORG. REPORT NUMBER	
7. AUTHOR(s) R. E. Eggert	8. CONTRACT OR GRANT NUMBER(s) DAAB07-78-C-2988	
9. PERFORMING ORGANIZATION NAME AND ADDRESS TRW Defense & Space Systems Group Power Conversion Electronics Department Redondo Beach, CA 90278	10. PROGRAM ELEMENT, PROJECT, TASK AREA & WORK UNIT NUMBERS 1F263702DG11-02-013	
11. CONTROLLING OFFICE NAME AND ADDRESS USA Electronics Technology & Devices Lab(ERADCOM) ATTN: DELET-PE Fort Monmouth, New Jersey 07703	12. REPORT DATE OCTOBER 1981	
	13. NUMBER OF PAGES 84	
14. MONITORING AGENCY NAME & ADDRESS (if different from Controlling Office)	15. SECURITY CLASS. (of this report) UNCLASSIFIED	
	15a. DECLASSIFICATION/DOWNGRADING SCHEDULE	
16. DISTRIBUTION STATEMENT (of this Report) Approved for public release; distribution unlimited.		
17. DISTRIBUTION STATEMENT (of the abstract entered in Block 20, if different from Report)		
18. SUPPLEMENTARY NOTES		
19. KEY WORDS (Continue on reverse side if necessary and identify by block number) Power Processor DC-DC Conversion Power Conversion Converters Power Conditioning		
20. ABSTRACT (Continue on reverse side if necessary and identify by block number) The 2.4KW DC-DC Converter/Regulator Power Module furnishes 0-75ADC over an output voltage range of 24 to 32VDC from a nominal 20-40VDC unregulated power source and can be used for battery charging from 5 to 75A. Remote output voltage sensing at the load circuit is provided to eliminate the IR drops of the power distribution cabling between the power module and the load. A series inductor/parallel inverter power stage is used to provide the output power control and regulation input/output ground isolation and protection.		

DD FORM 1 JAN 73 1473

EDITION OF 1 NOV 65 IS OBSOLETE

UNCLASSIFIED

SECURITY CLASSIFICATION OF THIS PAGE (When Data Entered)

UNCLASSIFIED

SECURITY CLASSIFICATION OF THIS PAGE(When Data Entered)

20. Abstract - (cont'd)

of the switching power transistors. The power supply is constructed in accordance with the Shelter-installed, Mobile C-E Equipment destined for shelter or van use without the fans used for cooling. The internal electronics are modularized according to circuit function with provision for easy removal or repair.

Reliability, efficiency, weight and size achieved are approximately 13,868 hours (MTBF), 85, 84.6 lbs., 1.96 cu. ft., respectively.

UNCLASSIFIED

SECURITY CLASSIFICATION OF THIS PAGE(When Data Entered)

NOTICES

Disclaimers

The citation of trade names and names of manufacturers in this report is not to be construed as official Government indorsement or approval of commercial products or services referenced herein.

Disposition

Destroy this report when it is no longer needed. Do not return it to the originator.

FORWARD

The author wishes to acknowledge the contribution to this work by the Army Project Monitor, Mr. Larry Groehl whose thorough review, comments and suggestion helped to improve the technical results.

TABLE OF CONTENTS

	<u>PAGE NO.</u>
1. INTRODUCTION	1
2. DESIGN PHILOSOPHY AND THEORY OF OPERATION	3
2.1 Power Stage	3
2.2 Block Diagram - DC to DC Power Processor	6
2.3 Component Considerations	10
2.4 Circuit Modifications Since the Original Development Model	10
3. SUMMARY OF REQUIREMENTS VS. CAPABILITIES	17
3.1 Requirement (Performance).	17
3.1.1 Duty Cycle	17
3.1.2 Output Voltage	17
3.1.3 Ripple	17
3.1.4 Recovery Time	18
3.1.5 Stability	18
3.1.6 Temperature Coefficient	18
3.1.7 Current Limiting	19
3.1.8 Efficiency	19
3.2 Reliability Prediction	20
4. SCHEMATIC DIAGRAMS	23
● DC-DC Power Processor (708808)	24
● Power Section (708819)	25
● Control Electronics (708823)	26
5. MECHANICAL DESIGN	27
6. TEST RESULTS	37
7. INSTRUMENTATIONS	38
8. DISCUSSION OF TEST RESULTS AND RECOMMENDATIONS	41
9. CONCLUSIONS	42
10. SUMMARY OF THE TEST DATA	43
11. APPENDIX	67

TABLE OF CONTENTS (Cont'd)

<u>FIGURES</u>		<u>PAGE NO.</u>
Figure 1	Schematic-Series Inductor/Parallel Inverter Power Stage	4
Figure 2	Series Inductor/Parallel Inverter Waveform . .	5
Figure 3	Block Diagram for the 2.4 KW DC-DC Converter Regulator	9
Figure 4	DC-DC Power Processor in the Open Position . .	29
Figure 5	Front Panel	30
Figure 6	Rear View of the Front Panel	31
Figure 7	Control Electronics Assembly.	32
Figure 8	Left Side Power Stage	33
Figure 9	Close-up of the Back Side of the Rear Panel . .	34
Figure 10	Rear Panel	35
Figure 11	DC-DC Power Processor Completely Assembled . .	36
Figure 12	2.4KW DC-DC Power Processor Load Bank	39

1. INTRODUCTION.

The U.S. Army Electronics Research & Development Command is developing standardized power processing modules for application in the different power subsystem configurations being planned for digital equipment in communications, data handling, surveillance, and weapon systems. This report presents the results of work performed under contract DAAB07-78-C-2988 for the U.S. Army Electronics Research & Development Command to develop and manufacture two DC-DC Power Processor Development Units.

The original demonstration model of the DC-DC Power Processor was developed under contract DAAB07-75-C-1324 in 1976. The fundamental design concept employed is the same under both contracts. The goals under this contract were to improve the Thermal and Electromagnetic Interface Designs and to evaluate; (1) a new power transistor to improve its switching characteristics to reduce its losses and; (2) an improved filter capacitor to control ripple characteristics at low operating temperature.

The specific objective of this contract was the development and manufacture of two developmental power processors that would provide precise, transient free, adjustable 24 to 32V, 75A output power from a 20-40 volt unregulated input voltage bus. To improve the reliability and performance; and reduce development, production, and logistic costs.

The basic power stage design is the same as that employed under the DAAB07-75-C-1324 contract. The basic feature of the power stage in this design, is the power inductor which has two windings, one in series with the power source and the parallel inverter power transformer center tap and the second winding in parallel with the output filter capacitor. During the on-time of the power transistors, the difference between the input source and the power transformer is stored in the inductor primary winding and during the off-time of the power transistor, the energy stored in the inductor is transferred directly to the output filter.

1. INTRODUCTION-(Cont'd)

A complete 2.4kW DC-DC converter regulator was designed, breadboarded, and tested, using the new power transistor and improved filter capacitor. It was made in such a way as to simulate the final units, in order to evaluate the EMI Design. The complete electrical design was packaged to fit into a 19 inch rack panel.

The DC-DC Power Processor was packaged into a Type 1-Sheltered Equipment with the following dimensions.

- Front Panel 19 x 10.5 inches. (48.3 x 26.7 cm)
- Main Chassis 17 inches (43.2 cm) deep
With a total weight of 84.6 lbs. (38.1 kg)

2. DESIGN PHILOSOPHY AND THEORY OF OPERATION.

As in the previous (6.2) development contract, the series Inductor/Parallel Inverter power stage is employed here. A brief discussion is presented in order to understand the circuit operation and the current and voltage waveforms on each of the main circuit components.

2.1 Power Stage.

Figure 1 is the schematic for the series inductor parallel inverter power stage. The circuit includes the series inductor L with a primary and secondary winding, power transformer T, power transistor Q1 and Q2, output rectifiers CR1, CR2 and CR3 and output filter capacitor C. The power transistors are controlled by a driver stage to provide the correct pulse width & pulse position modulation to satisfy the input/output voltage requirements. In this example, both the inductor and transformer turns ratios are assumed to be one.

Figure 2 presents the transformer voltage, inductor voltage, power transistor Q1 current and voltage, power transistor Q2 current and voltage, and rectifier CR1, CR2 and CR3 currents. One complete cycle is presented in Figure 2, Q1 ON, Q1 & Q2 OFF, Q2 ON and Q1 and Q2 OFF. The example assumes 40 VDC input and 20 VDC output.

When Q1 is on, the 40 volt supply voltage is across the series inductor and power transformer. The change in the power transistor current I is due to the flux swing of inductor L ($E = -L \frac{di}{dt}$). This same current magnitude is flowing in the output diode CR2 to the output load and filter capacitor. The impressed voltages across transistor Q2 is equal to 40 volt ($2 \times E_0$).

When Q1 turns off, the energy stored in inductor L is supplied directly to output filter capacitor through output diode CR1. The impressed voltage across the power transistors is E in plus $EN_1(L)$ and equals 60V.

When transistor Q2 is turned on and turned off, the same type of waveform exists as during the transistor Q1 operation.

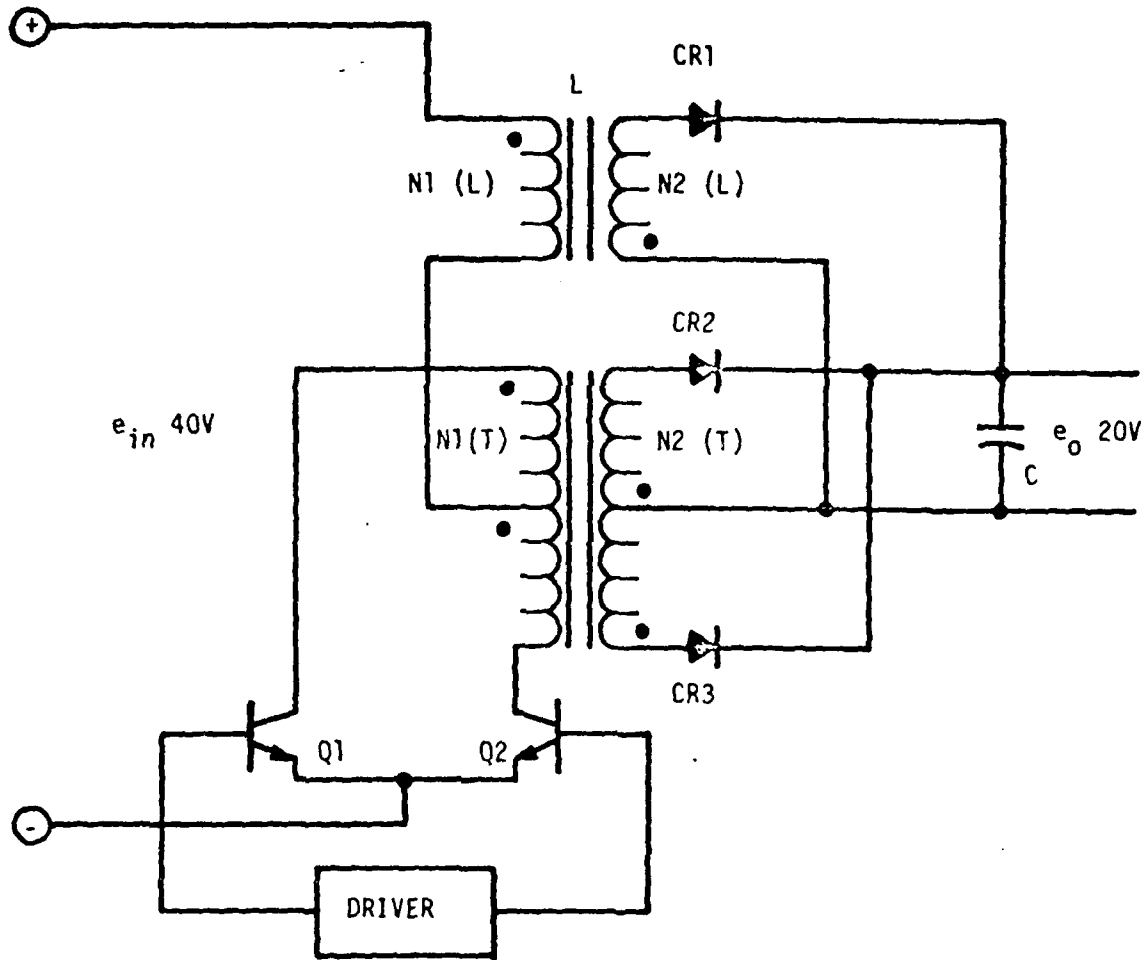

ASSUME $N1(L) = N2(L)$ & $N1(T) = N2(T)$

$e_{in} = 40V$

$e_o = 20V$

FIGURE 1 SCHEMATIC-SERIES INDUCTOR/PARALLEL INVERTER POWER STAGE

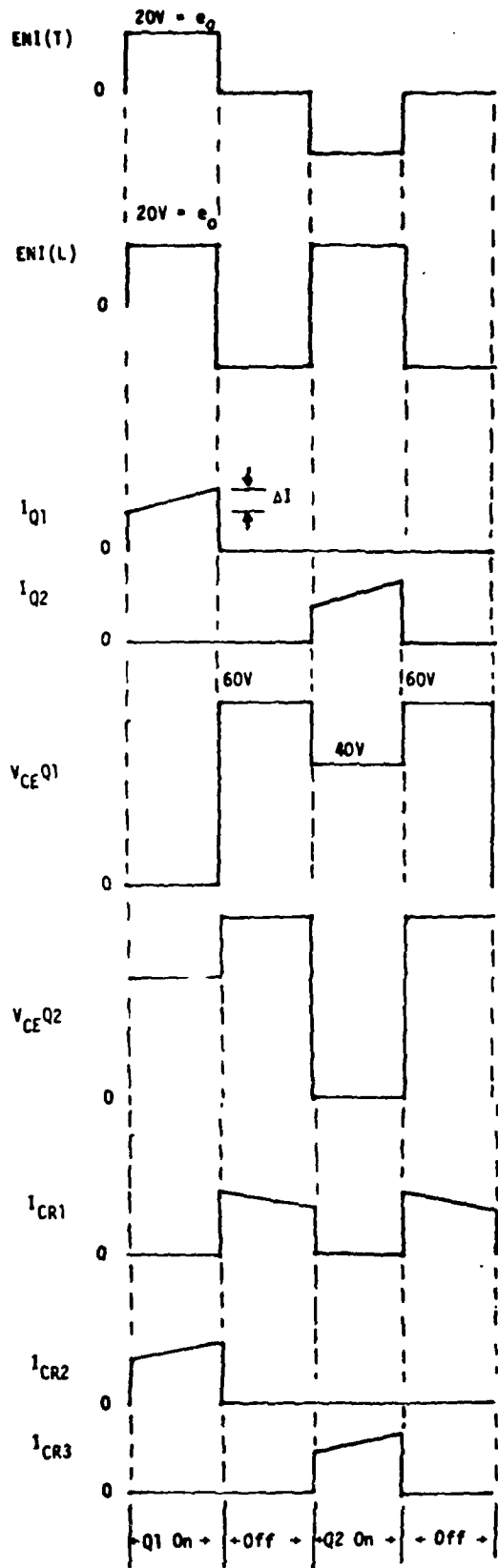

FIGURE 2 SERIES INDUCTOR/PARALLEL INVERTER WAVEFORM

2.1 Power Stage - (cont'd).

It is interesting to note the basic difference of the transistor voltages in the power stage configuration as shown in Figure 2 when compared with a conventional parallel inverter. When transistor Q1 is turned ON, the voltage across Q2 equals $2 \times e_{in}$ vs. $2 \times e_o$ as in this configuration. When transistor Q1 is turned OFF, the voltage across Q2 equals e_{in} vs. $e_{in} + e_o$ as in this configuration. The net effect is that the peak voltage stress is reduced to 75% of the conventional design configuration.

The basic advantages of this power stage configuration are: (1) lower peak voltage stress on the power transistor; (2) the series inductor always provides an impedance in series with the power transistor and therefore, has inherent current limit during output short, power transformer saturation and overlap of the power transistor Q1 and Q2.

The penalty of the design is that inductor L is about 50% larger due to having two windings instead of one in the conventional circuit and that an additional output diode is required.

The improved reliability due to the reduced voltage stress and current limiting greatly offsets the slight increase in the weight of the inductor and the addition of an extra power diode.

The next section will explain in detail the phase displacement, output load sharing and control techniques for output voltage regulation and output current limiting.

2.2 BLOCK DIAGRAM - DC TO DC POWER PROCESSOR.

The Block Diagram of the DC to DC Power Processor is shown in Figure 3.

The input DC power (20-40V) is supplied into an input EMI Filter, input circuit breaker and input power filter. The DC power is then distributed to the four power modules (two on each side panel). The power modules consists of four identical series inductor/parallel inverters. Each one of which handles 1/4 of the total input power.

2.2 BLOCK DIAGRAM - DC TO DC POWER PROCESSOR-(Cont'd)

The output from each power stage goes to a common output filter, output shunt, output circuit breaker, and output EMI Filter.

Each power stage includes a series power inductor, power transformer and push/pull power transistors. The power transistors are driven by a proportional current drive by means of a digital signal from the control logic. The control logic receives signals from the feedback control system ring counter, input DC line voltage and instantaneous transformer primary current and generates the correct digital control logic for the push/pull power transistor.

The control logic contains a flip-flop that turns the two power transistors on and off. The on time is initiated by a signal from the ring counter. The turnoff is initiated by the volt-second control in the control logic or via the primary peak current sensor.

The volt second control senses the input voltage and provides a constant volt-sec of energy to go into the power inductor and output transformer. The volt-sec control in each power module is pre-selected in test, so that, all power modules are carrying 1/4 of the total output power. By this means, no additional electronics are required to cause load sharing.

The peak current sensor constantly monitors the power transformer primary current and therefore, the power transistor collector current initiates a turn off if the instantaneous peak current is beyond a pre-determined threshold limit. This action provides inherent transistor protection during all transient and steady state modes of operation.

A common output voltage regulator and voltage divider/remote sense network monitor the output dc voltage in conjunction with the AC signal from the output filter, determines an output voltage to the voltage-to-frequency oscillator that commands the turn-on of the four separate phase displaced power modules through the ring counter.

2.2 BLOCK DIAGRAM - DC TO DC POWER PROCESSOR. (Con't)

The remote sense circuit is configured in such a way as to prevent loss of control, if the sense leads are opened or short-circuited or reversed across the output to be controlled.

The net output voltage of the error amplifier provides a voltage level to the voltage-to-frequency oscillator which is the heart of this control system. Therefore, all power modules operate at the same frequency. The frequency is proportional to the input amplified error voltage.

The power module phase displacement is controlled by the ring counter which senses sequential pulses to each of the four power modules to initiate the power transistor turn-on.

The signal from the output shunt and current regulator over-rides the voltage regulator and reduces the overall operating frequency of the voltage-to-frequency oscillator during overload operations.

Front panel adjustments are provided to allow for the 24 to 32VDC output voltage adjustment and for the 0 to 75A output current limit.

The output of the voltage-to-frequency oscillator is processed through an isolation transformer that isolates the output power ground from the input power ground and commands the ring counter to provide the correct duty cycle of the four separate power modules.

An undervoltage/overvoltage sensor monitor the DC input voltage and can inhibit the ring counter operation during abnormal input line condition (less than 20V and greater than 40VDC).

The undervoltage circuit can be disabled normally and is not recommended for use with power supplies with poor load regulation ($\geq 10\%$ no load to full load) as unwanted cycling may occur at the undervoltage trip circuit. Instructions for providing this function are provided.

The front panel meter can monitor the DC output voltage or the DC output current.

Control electronics power is obtained from the main DC input voltage through a fuse to a control electronics DC-DC Converter. The control electronics DC-DC converter provides +10 and +5V output which is common with the input power ground and a +10V and 21V outputs for the output voltage and current regulators.

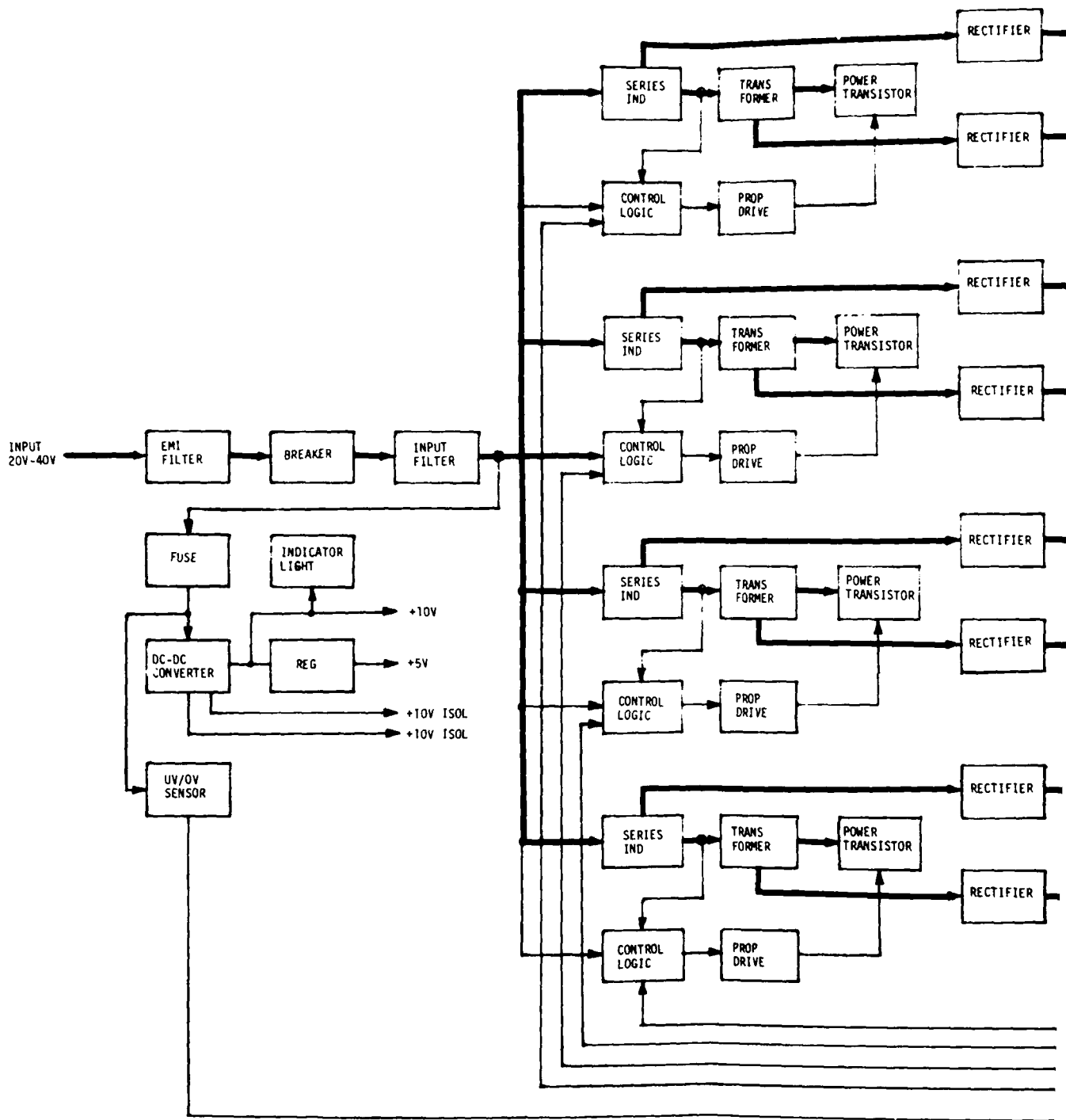

FIGURE 3 BLOCK DIAGRAM FOR THF 2.4KW DC-DC

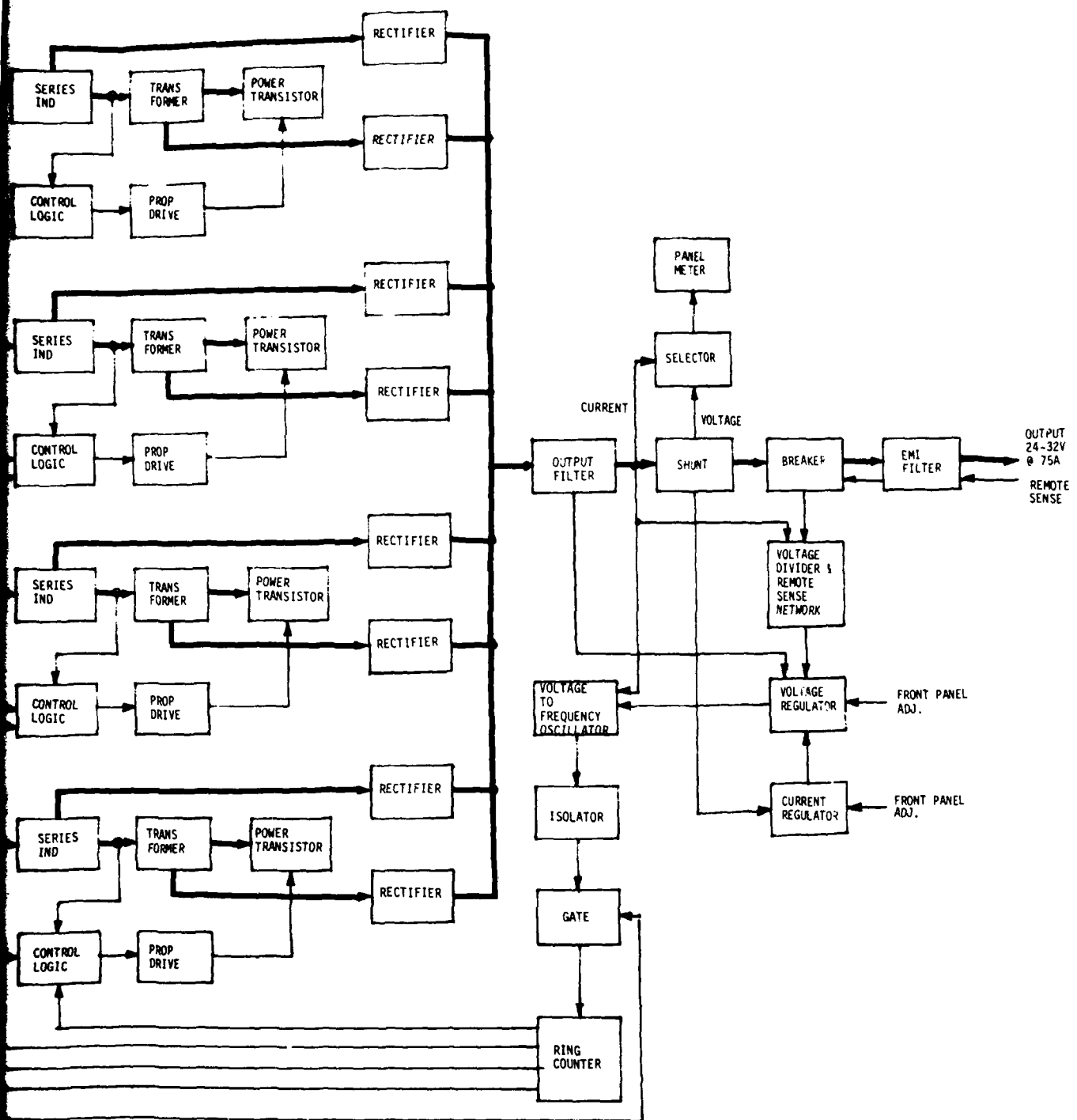

FIGURE 3 BLOCK DIAGRAM FOR THE 2.4KW DC-DC CONVERTER/REGULATOR

2.3 Component Considerations.

Power Transistor

An improved power transistor was employed in this design. This modification to the design allowed a single transistor to be used in place of the parallel transistors employed in the original developmental model.

The transistor used is the Solitron #55EJ106. The advantages of this transistor are:

- It switches faster.
- Has lower saturation voltages.
- Better thermal design.

Filter Capacitor

One common capacitor was used in both stages of the input filter and for the output filter capacitors.

This capacitor is a 2800 μ F 150VDC capacitor MEPCO/ELECTRA, INC. 91F series, aluminum Electrolytic, computer grade capacitor.

Its advantages are very low, equivalent series resistance which is maintained at low temperature, i.e., -55°C.

2.4 Circuit Modifications Since the Original Development Model.

- Improved input filter configurations.
- Deletion of optical isolation.
- Modified remote sensing circuit.
- Added energy recovery networks to the power stages.
- Modification to the undervoltage protection circuit.

2.4 Circuit Modifications since the Original Development Model.(Cont'd)

Input Filter

The input filter configuration is as shown:

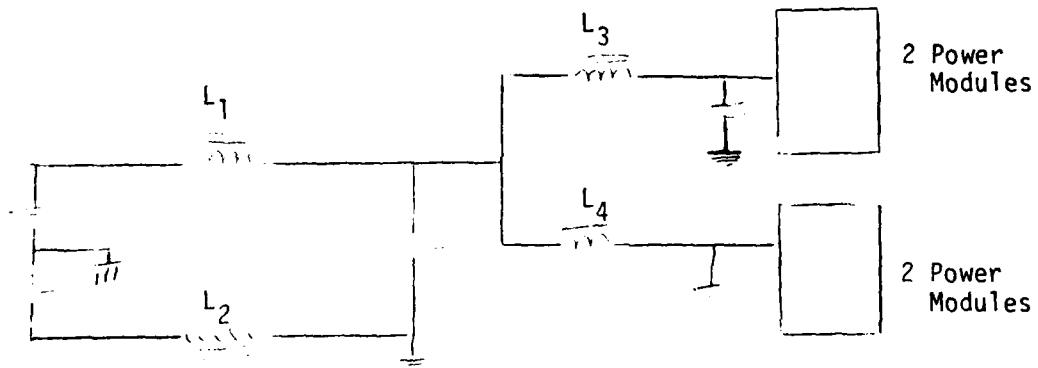

The advantages of this configuration are, it reduces the circulating currents between the two halves of the power modules via L_3 , L_4 and L_1 , L_2 , and it provides common mode filtering capability.

The expected (Based upon computer analysis) performance of this two stage filter is 1mA pk reflected into the power source by the power processor as shown below:

Input: Large signal due to Power source ripple.

$$I = 2A/cm$$

$$t = 5msec/cm$$

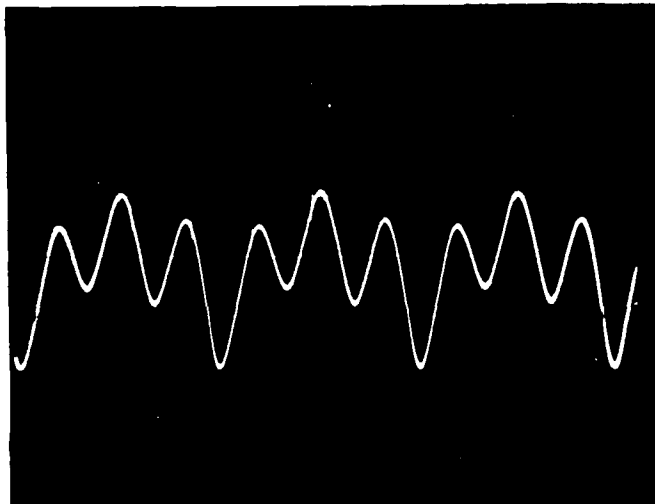

The above blown up.

$$T = 50mA/cm$$

$$t = 20\mu sec./cm$$

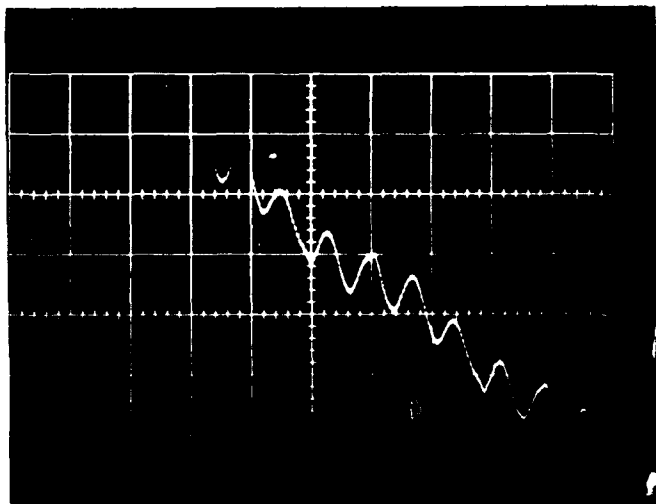

The MIL-STD-462 (EMI) test set-up degrades the input filter capability as shown below.

This photo was taken using a battery as a source and without the $10\mu\text{fd}$ capacitors connected.

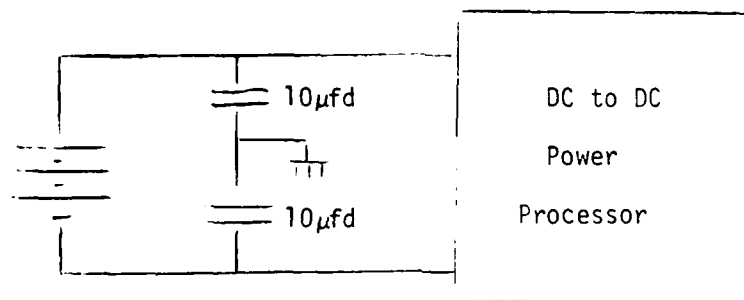

$$I = 25\text{mA/cm}$$

$$t = 20\mu\text{sec/cm}$$

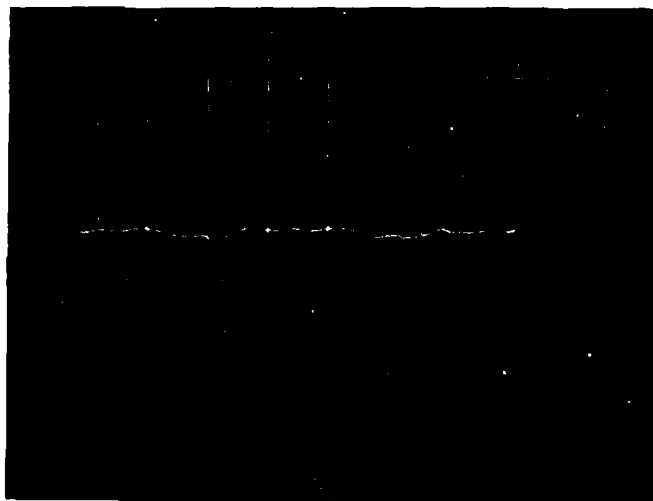

DELETION OF OPTICAL ISOLATOR

Due to noise consideration relative to the optical isolator previously used to provide isolation for the control electronics and the output return, the optical isolator has been removed. In its place, a small pulse transformer has been inserted to the circuit configuration, as is shown below:

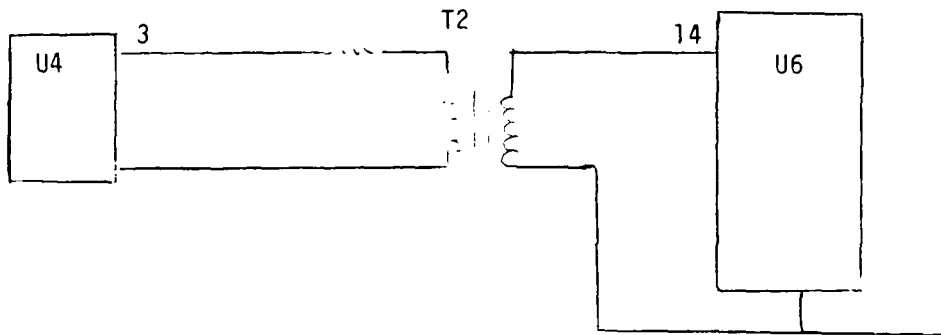

The advantage of this circuit over the one used previously is better noise immunity in this critical location of the control electronics while providing the necessary input to output isolation.

REMOTE SENSING

This circuit was modified to provide more protection in the event something would happen to the remote sense leads other than an open circuit.

The circuit is as shown:

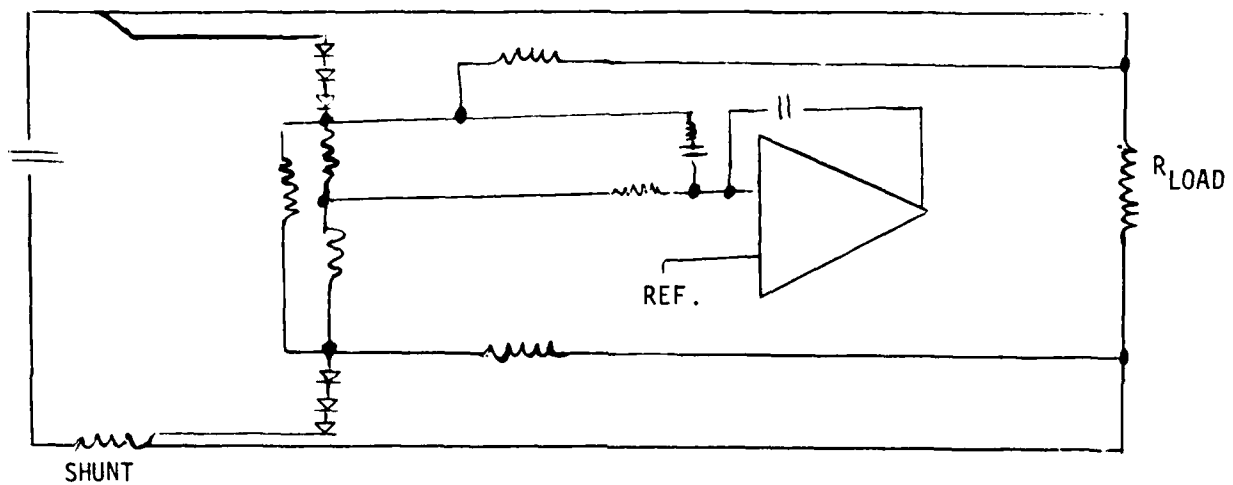

The advantages of this circuit are:

The sense leads can be opened or shorted (either to ground or together) or they can be reversed without losing control of the DC to DC Power Processor.

ENERGY RECOVERY CIRCUIT

These circuits were added primarily to reduce the voltage stresses on the power transistors. These transistors are more delicate than the originals, although they switch faster and have lower saturation voltages.

These circuits return part of the switched energy back to the power source as well as reduce the transistor collector to emitter voltage stress.

The circuit is as follows:

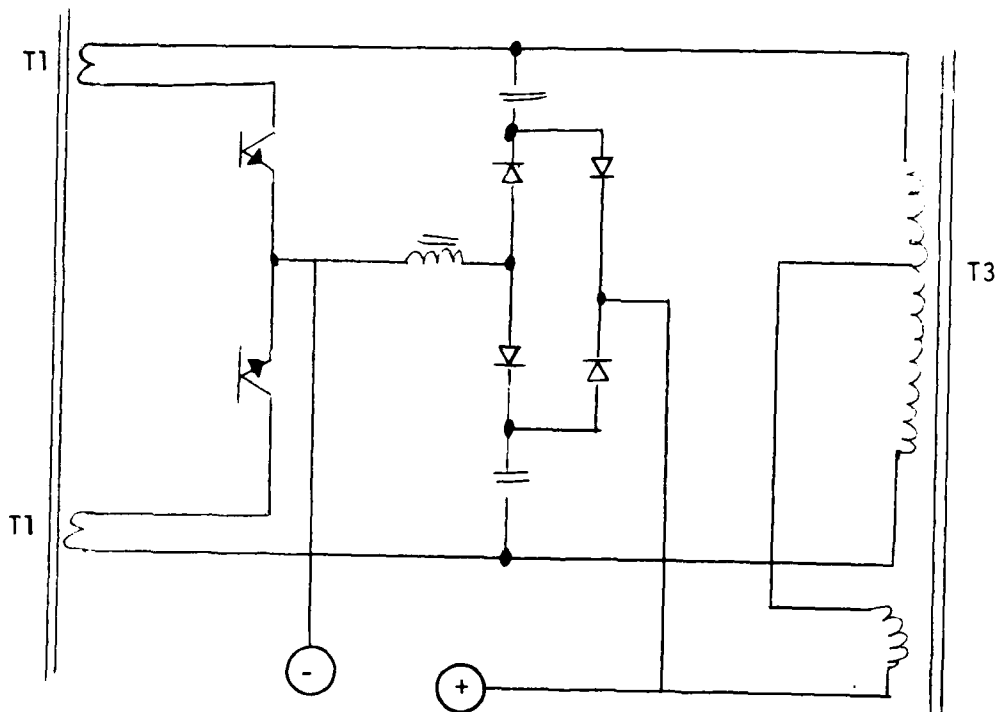

3.0 Summary of Requirements Vs Capabilities

Section 3.1 Requirement (Performance)	TEST RESULTS
<p>3.1.1 Duty Cycle. The equipment shall be capable of meeting all the requirement of 3.4 on a continuous duty basis.</p>	<p>All test results are continuous duty.</p>
<p>3.1.2 Output Voltage.</p> <p>a) The voltage across the output of the power processor shall be 28.0 volts $\pm 1\%$ over the load range of 0-75 Amperes.</p> <p>b) The output voltage shall also be adjustable over the range of 24.0 to 32.0 volts by an external locking type control and shall be $\pm 1\%$ of the voltage setting over the load range of from 0-75 Amperes.</p>	<p>a) Regulation is within 0.1% over 0 to 75 Amperes load range.</p> <p>b) (Adjust Range) $21.3V \leq V_{out} \leq 32.4V$ At $V_{out} = 24V$ Regulation is within 0.10% At $V_{out} = 32V$ Regulation is within 0.10%</p>
<p>3.1.3 Ripple.</p> <p>a) The Rms ripple shall not exceed 0.5% at any load from 0 load to full load.</p> <p>b) The peak to peak ripple voltage including switching spikes and other noise components shall not exceed $\pm 1\%$ at any output condition from 0 load to full load. $20 \text{ Hz} \leq f < 40\text{MHz}$</p>	<p>a) $< 0.1\%$</p> <p>b) The peak to peak ripple $\leq +0.63\%$ $20\text{Hz} \leq f \leq 10\text{MHz}$ (Worst Case)</p>

3.0 Summary of Requirements Vs Capabilities

Section 3.1 Requirement (Performance)	TEST RESULTS
<p>3.1.4 <u>Recovery Time.</u></p> <p>a) The output voltage of the Power Processor shall recover to 28.0 volts +1% within 25 milliseconds when the load is switched from no load to full load and from full load to no load.</p> <p>b) The maximum instantaneous overshoot voltage under these conditions, and for any turn-on or turn-off condition of the Power Processor shall not exceed 10% on the nominal voltage (28.0V)</p>	<p>a) $T_{\text{recovery}} < 15\text{msec.}$ No load to full load.</p> <p>* $T_{\text{recovery}} > 25\text{msec.}$ Full load to no load.</p> <p>b) $\bar{V}_{\text{instantaneous}} = 2.5\%$</p>
<p>3.1.5 <u>Stability.</u> Output voltage drift at a constant load and ambient temperature shall not exceed 0.5% over a period of 24 hours.</p>	<p>Output voltage drift $< 0.07\%$</p>
<p>3.1.6 <u>Temperature Coefficient.</u> Change in output voltage as a function of ambient temperature shall not exceed 0.02 percent per degree F over the specified operating temperature range.</p>	<p>The change in voltage is $.00073\%/^{\circ}\text{F}$ $-26^{\circ}\text{F} \leq T \leq 145^{\circ}\text{F}$</p>

* A BLEEDER RESISTOR (WITH AN ATTENDANT LOSS OF EFFICIENCY) IS REQUIRED TO MEET THIS REQUIREMENT.

3.0 Summary of Requirements Vs Capabilities

Section 3.1 Requirement (Performance)	TEST RESULTS
<p>3.1.7 <u>Current Limiting.</u></p> <p>a) Automatic control circuitry shall limit the output current to a maximum value of 75 Amperes +5%, -0%, to protect the power processor from overload and automatically restore the output when the overload is removed.</p> <p>b) The current limiting shall be manually adjustable by means of a front panel control over the range of 5 to 75 Amperes.</p>	<p>a) Current regulation is $\pm 1\%$ due to input voltage change at any setting of output current.</p> <p>b) Adjust Range $2.4A \leq I_{out} \leq 75.6A$</p>
<p>3.1.8 <u>Efficiency.</u> The overall efficiency of the power processor shall not be less than 85% at full load, nominal input voltage.</p>	<p>$\eta = 87.4\%$ AT 28Vinput, 75A Load AT +75°F.</p> <p>$\eta = 86.1\%$ AT 28Vinput, 75A Load AT +145°F</p> <p>$\eta = 88.3\%$ AT 28Vinput, 75A Load AT -26°F</p>

3.2 Reliability Prediction

A reliability prediction was performed early in the contract CLIN, Item C001. This prediction is revised here to include the part changes (quantity, type, stress). Both prediction are based upon MIL-HBK-217B. Table 1, presents the part types, failure rate, quantity of components used and total failure rate.

The analysis shows a 13,868 hour meantime between failure, and this exceeds the 2,000MTBF contract goal.

Revised Reliability Prediction

	Failure Rate Per 10^9 Hours
Front Panel - - - - -	3546
Back Panel - - - - -	11024
Chassis - - - - -	9554
Side Panels - - - - -	34304
Control Electronics - - - - -	<u>13677</u>

$$\Sigma \tau_p = 72105 \times 10^{-9}$$

$$MBTF = 1/\tau_p = 13,868 \text{ hours}$$

Exceeds 2,000 Hr. Design Goal.

FRONT PANEL

<u>Part Type</u>	<u>Failure Rate Per 10⁹ Hour</u>	<u>Quantity</u>	<u>Total Failure Rate Per 10⁹ Hour.</u>
Switch, Toggle	1497	11	1497
Resistor, Variable	90	2	180
Resistor, Film	9	1	9
Meter	500	1	500
Connector(9)	80	2	160
Fuse Holder	100	2	200
Circuit Breaker	500	2	1000
			<u>TOTAL: 3546</u>

BACK PANEL

Inductors (Power)	503	4	2012
Connectors (Power)	4506	2	9012
			<u>TOTAL: 11024</u>

CHASSIS

Capacitors, Alum.	630	15	9450
Shunt	10	1	10
Transformer, Pulse	94	1	94
			<u>TOTAL: 9554</u>

TABLE 1

POWER MODULE

<u>PART TYPE</u>	<u>Failure Rate Per 10⁹ Hour</u>	<u>Quantity</u>	<u>Total Failure Rate Per 10⁹ Hour</u>
Inductor, Power	503	2	1006
Connector	80	1	80
Transistor, Power	1100	2	2200
Diode, Power	75	3	225
Capacitor, Alum	630	6	3780
Capacitor, Polycarb	34	1	34
Transformer, Pulse	94	2	188
Capacitor, Ceramic	13	4	52
Diode, Med. Power	75	5	375
Inductor, Pulse	94	1	94
Transformer, Power	503	1	503
Resistor, Carbon	7.7	5	39
			<u>8576</u>

Total for 4 Modules = 34304

CONTROL ELECTRONICS

Capacitor, Tant. Foil	17	16	272
Capacitor, Ceramic	13	43	559
Capacitor, Glass	7.5	12	90
Resistors, Film	9	80	720
Resistors, Wirewound	26	17	442
Resistors, Carbon	7.7	42	323
Diode, General Purpose	75	10	750
Diode, Med. Power	75	23	1725
Diode, Zener	910	2	1820
Transistor, Low Power	110	17	1870
Transistor, Power	1100	1	1100
IC, Voltage Comparator	186	6	1116
IC, Op-Amp	186	2	372
IC, Timer	193	5	965
IC, CMOS	133	1	133
IC, Regulator	175	4	700
IC, TTL	45	16	720
			<u>13677</u>

TABLE 1 (cont'd)

4. SCHEMATIC DIAGRAMS

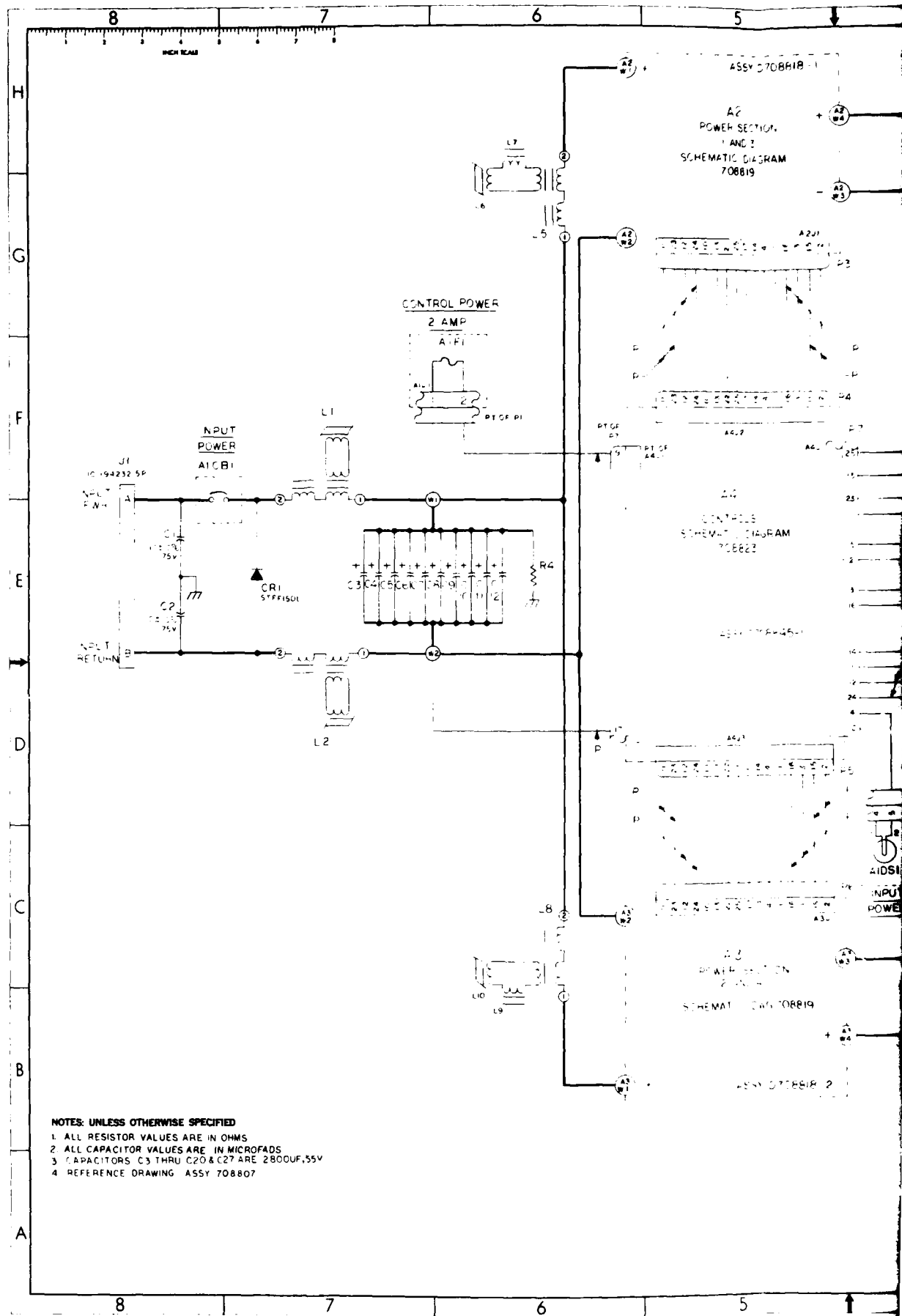

- NOTES: UNLESS OTHERWISE SPECIFIED**
1. ALL RESISTOR VALUES ARE IN OHMS
 2. ALL CAPACITOR VALUES ARE IN MICROFADS
 3. CAPACITORS C3 THRU C20 & C27 ARE 2800UF,55V
 4. REFERENCE DRAWING ASSY 708807

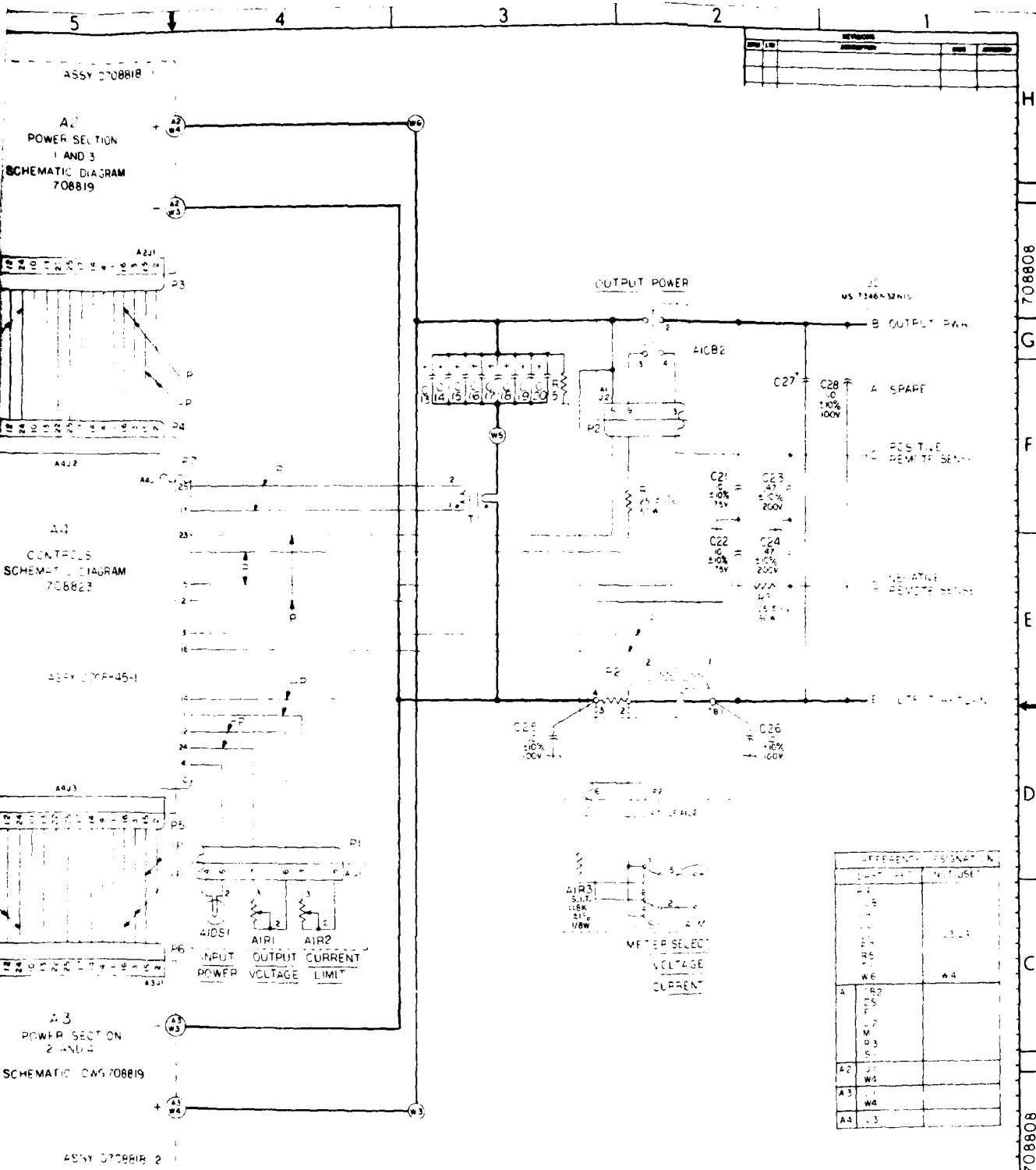

DIFFERENTIAL SIGNATURE	
DESCRIPTION	NOT USED
W1	
W2	
W3	
W4	
W5	
W6	
W7	
W8	
W9	
W10	
A1	
A2	
A3	
A4	

QTY REQD PER ASSY		PART OR IDENTIFYING NO		DESCRIPTION OF COMPONENTS		INTERNAL	SPR	DEL	PREL	REV
UNLESS OTHERWISE SPECIFIED		DAAB07-78-C-2988		THE FOLLOWING QTY HAVE BEEN ATTACHED TO THIS PRINT						
1. DO NOT SCALE DRAWING		FOR CHECKS		DATE		TRW				
2. REFER TO PER DIM LIST		ALL DIMENSIONS ARE IN INCHES		CHECKED BY		SCHEMATIC DIAGRAM - DC TO DC POWER PROCESSOR				
3. DIMENSIONS ARE TO CENTER UNLESS OTHERWISE SPECIFIED		ALL DIMENSIONS ARE TO CENTER UNLESS OTHERWISE SPECIFIED		DATE		E 11982 708808				
4. SURFACE FINISH SHALL BE		ALL DIMENSIONS ARE TO CENTER UNLESS OTHERWISE SPECIFIED		DATE						
5. REMOVE BURRS AND CHAMFER EDGES		ALL DIMENSIONS ARE TO CENTER UNLESS OTHERWISE SPECIFIED		DATE						
6. CONTOURING SHALL BE TO CENTER UNLESS OTHERWISE SPECIFIED		ALL DIMENSIONS ARE TO CENTER UNLESS OTHERWISE SPECIFIED		DATE						
7. IDENTIFICATION SHALL BE AS SPECIFIED IN 3.1		ALL DIMENSIONS ARE TO CENTER UNLESS OTHERWISE SPECIFIED		DATE						
8. IDENTIFICATION SHALL BE AS SPECIFIED IN 3.1		ALL DIMENSIONS ARE TO CENTER UNLESS OTHERWISE SPECIFIED		DATE						
9. IDENTIFICATION SHALL BE AS SPECIFIED IN 3.1		ALL DIMENSIONS ARE TO CENTER UNLESS OTHERWISE SPECIFIED		DATE						
10. IDENTIFICATION SHALL BE AS SPECIFIED IN 3.1		ALL DIMENSIONS ARE TO CENTER UNLESS OTHERWISE SPECIFIED		DATE						
11. IDENTIFICATION SHALL BE AS SPECIFIED IN 3.1		ALL DIMENSIONS ARE TO CENTER UNLESS OTHERWISE SPECIFIED		DATE						
12. IDENTIFICATION SHALL BE AS SPECIFIED IN 3.1		ALL DIMENSIONS ARE TO CENTER UNLESS OTHERWISE SPECIFIED		DATE						
13. IDENTIFICATION SHALL BE AS SPECIFIED IN 3.1		ALL DIMENSIONS ARE TO CENTER UNLESS OTHERWISE SPECIFIED		DATE						
14. IDENTIFICATION SHALL BE AS SPECIFIED IN 3.1		ALL DIMENSIONS ARE TO CENTER UNLESS OTHERWISE SPECIFIED		DATE						
15. IDENTIFICATION SHALL BE AS SPECIFIED IN 3.1		ALL DIMENSIONS ARE TO CENTER UNLESS OTHERWISE SPECIFIED		DATE						
16. IDENTIFICATION SHALL BE AS SPECIFIED IN 3.1		ALL DIMENSIONS ARE TO CENTER UNLESS OTHERWISE SPECIFIED		DATE						
17. IDENTIFICATION SHALL BE AS SPECIFIED IN 3.1		ALL DIMENSIONS ARE TO CENTER UNLESS OTHERWISE SPECIFIED		DATE						
18. IDENTIFICATION SHALL BE AS SPECIFIED IN 3.1		ALL DIMENSIONS ARE TO CENTER UNLESS OTHERWISE SPECIFIED		DATE						
19. IDENTIFICATION SHALL BE AS SPECIFIED IN 3.1		ALL DIMENSIONS ARE TO CENTER UNLESS OTHERWISE SPECIFIED		DATE						
20. IDENTIFICATION SHALL BE AS SPECIFIED IN 3.1		ALL DIMENSIONS ARE TO CENTER UNLESS OTHERWISE SPECIFIED		DATE						
21. IDENTIFICATION SHALL BE AS SPECIFIED IN 3.1		ALL DIMENSIONS ARE TO CENTER UNLESS OTHERWISE SPECIFIED		DATE						
22. IDENTIFICATION SHALL BE AS SPECIFIED IN 3.1		ALL DIMENSIONS ARE TO CENTER UNLESS OTHERWISE SPECIFIED		DATE						
23. IDENTIFICATION SHALL BE AS SPECIFIED IN 3.1		ALL DIMENSIONS ARE TO CENTER UNLESS OTHERWISE SPECIFIED		DATE						
24. IDENTIFICATION SHALL BE AS SPECIFIED IN 3.1		ALL DIMENSIONS ARE TO CENTER UNLESS OTHERWISE SPECIFIED		DATE						
25. IDENTIFICATION SHALL BE AS SPECIFIED IN 3.1		ALL DIMENSIONS ARE TO CENTER UNLESS OTHERWISE SPECIFIED		DATE						
26. IDENTIFICATION SHALL BE AS SPECIFIED IN 3.1		ALL DIMENSIONS ARE TO CENTER UNLESS OTHERWISE SPECIFIED		DATE						
27. IDENTIFICATION SHALL BE AS SPECIFIED IN 3.1		ALL DIMENSIONS ARE TO CENTER UNLESS OTHERWISE SPECIFIED		DATE						
28. IDENTIFICATION SHALL BE AS SPECIFIED IN 3.1		ALL DIMENSIONS ARE TO CENTER UNLESS OTHERWISE SPECIFIED		DATE						
29. IDENTIFICATION SHALL BE AS SPECIFIED IN 3.1		ALL DIMENSIONS ARE TO CENTER UNLESS OTHERWISE SPECIFIED		DATE						
30. IDENTIFICATION SHALL BE AS SPECIFIED IN 3.1		ALL DIMENSIONS ARE TO CENTER UNLESS OTHERWISE SPECIFIED		DATE						
31. IDENTIFICATION SHALL BE AS SPECIFIED IN 3.1		ALL DIMENSIONS ARE TO CENTER UNLESS OTHERWISE SPECIFIED		DATE						
32. IDENTIFICATION SHALL BE AS SPECIFIED IN 3.1		ALL DIMENSIONS ARE TO CENTER UNLESS OTHERWISE SPECIFIED		DATE						
33. IDENTIFICATION SHALL BE AS SPECIFIED IN 3.1		ALL DIMENSIONS ARE TO CENTER UNLESS OTHERWISE SPECIFIED		DATE						
34. IDENTIFICATION SHALL BE AS SPECIFIED IN 3.1		ALL DIMENSIONS ARE TO CENTER UNLESS OTHERWISE SPECIFIED		DATE						
35. IDENTIFICATION SHALL BE AS SPECIFIED IN 3.1		ALL DIMENSIONS ARE TO CENTER UNLESS OTHERWISE SPECIFIED		DATE						
36. IDENTIFICATION SHALL BE AS SPECIFIED IN 3.1		ALL DIMENSIONS ARE TO CENTER UNLESS OTHERWISE SPECIFIED		DATE						
37. IDENTIFICATION SHALL BE AS SPECIFIED IN 3.1		ALL DIMENSIONS ARE TO CENTER UNLESS OTHERWISE SPECIFIED		DATE						
38. IDENTIFICATION SHALL BE AS SPECIFIED IN 3.1		ALL DIMENSIONS ARE TO CENTER UNLESS OTHERWISE SPECIFIED		DATE						
39. IDENTIFICATION SHALL BE AS SPECIFIED IN 3.1		ALL DIMENSIONS ARE TO CENTER UNLESS OTHERWISE SPECIFIED		DATE						
40. IDENTIFICATION SHALL BE AS SPECIFIED IN 3.1		ALL DIMENSIONS ARE TO CENTER UNLESS OTHERWISE SPECIFIED		DATE						
41. IDENTIFICATION SHALL BE AS SPECIFIED IN 3.1		ALL DIMENSIONS ARE TO CENTER UNLESS OTHERWISE SPECIFIED		DATE						
42. IDENTIFICATION SHALL BE AS SPECIFIED IN 3.1		ALL DIMENSIONS ARE TO CENTER UNLESS OTHERWISE SPECIFIED		DATE						
43. IDENTIFICATION SHALL BE AS SPECIFIED IN 3.1		ALL DIMENSIONS ARE TO CENTER UNLESS OTHERWISE SPECIFIED		DATE						
44. IDENTIFICATION SHALL BE AS SPECIFIED IN 3.1		ALL DIMENSIONS ARE TO CENTER UNLESS OTHERWISE SPECIFIED		DATE						
45. IDENTIFICATION SHALL BE AS SPECIFIED IN 3.1		ALL DIMENSIONS ARE TO CENTER UNLESS OTHERWISE SPECIFIED		DATE						
46. IDENTIFICATION SHALL BE AS SPECIFIED IN 3.1		ALL DIMENSIONS ARE TO CENTER UNLESS OTHERWISE SPECIFIED		DATE						
47. IDENTIFICATION SHALL BE AS SPECIFIED IN 3.1		ALL DIMENSIONS ARE TO CENTER UNLESS OTHERWISE SPECIFIED		DATE						
48. IDENTIFICATION SHALL BE AS SPECIFIED IN 3.1		ALL DIMENSIONS ARE TO CENTER UNLESS OTHERWISE SPECIFIED		DATE						
49. IDENTIFICATION SHALL BE AS SPECIFIED IN 3.1		ALL DIMENSIONS ARE TO CENTER UNLESS OTHERWISE SPECIFIED		DATE						
50. IDENTIFICATION SHALL BE AS SPECIFIED IN 3.1		ALL DIMENSIONS ARE TO CENTER UNLESS OTHERWISE SPECIFIED		DATE						

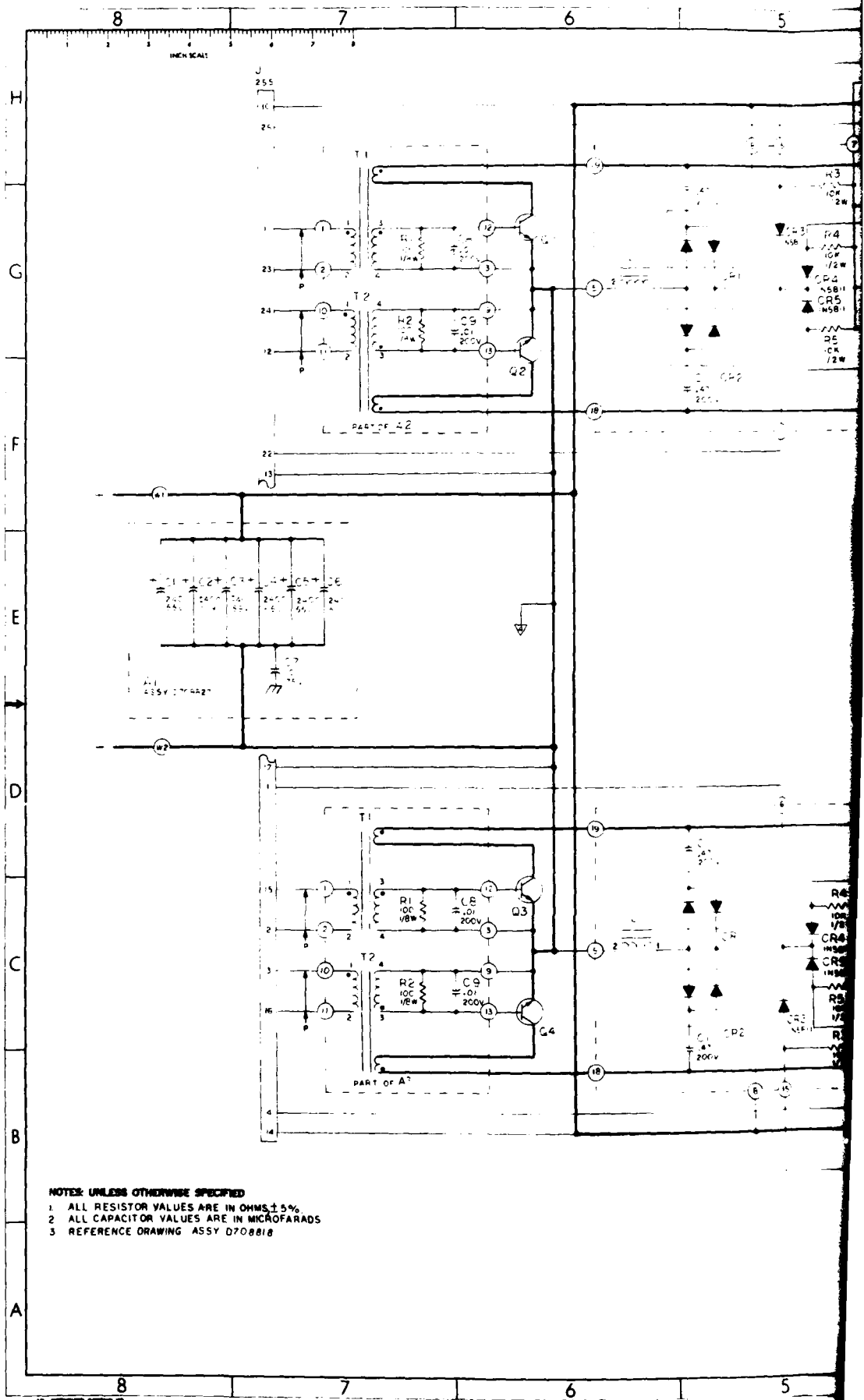

NOTES: UNLESS OTHERWISE SPECIFIED
 1 ALL RESISTOR VALUES ARE IN OHMS $\pm 5\%$.
 2 ALL CAPACITOR VALUES ARE IN MICROFARADS
 3 REFERENCE DRAWING ASSY D708818

10 9 8 7 6 5 4

CA
1A50
1C10
1C10
1C10
1C10

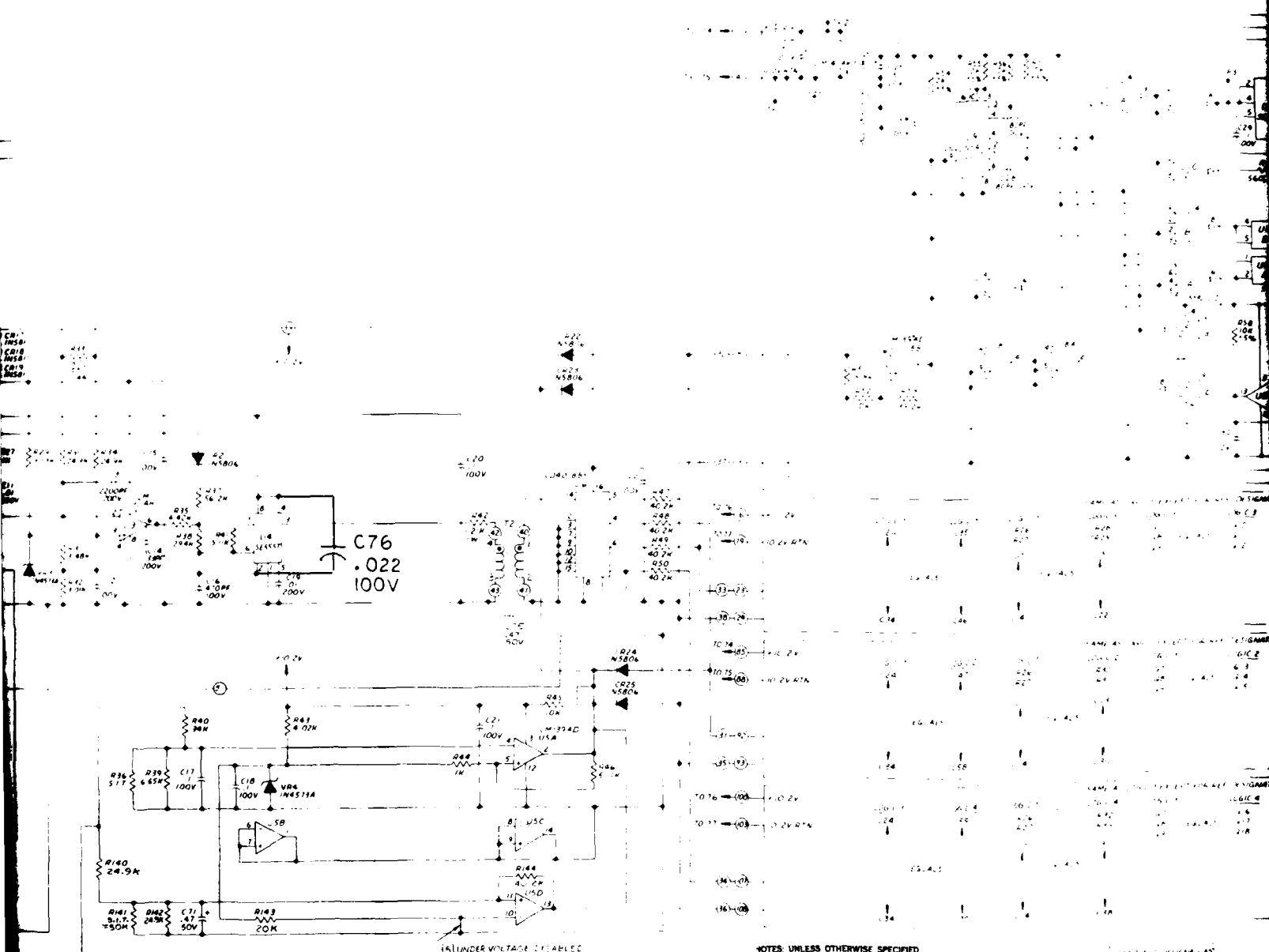

- NOTES: UNLESS OTHERWISE SPECIFIED
1. ALL RESISTOR VALUES ARE OHMS, UNLESS OTHERWISE SPECIFIED
 2. ALL CAPACITOR VALUES ARE IN MICROFARADS, UNLESS OTHERWISE SPECIFIED
 3. C10, C11, C12, C13, C14, C15, C16, C17, C18, C19, C20, C21, C22, C23, C24, C25, C26, C27, C28, C29, C30, C31, C32, C33, C34, C35, C36, C37, C38, C39, C40, C41, C42, C43, C44, C45, C46, C47, C48, C49, C50, C51, C52, C53, C54, C55, C56, C57, C58, C59, C60, C61, C62, C63, C64, C65, C66, C67, C68, C69, C70, C71, C72, C73, C74, C75, C76, C77, C78, C79, C80, C81, C82, C83, C84, C85, C86, C87, C88, C89, C90, C91, C92, C93, C94, C95, C96, C97, C98, C99, C100
 4. REFERENCE DRAWINGS: ASSY DRAWING, UNIT SCHEMATIC, ALGAM DRAWING
 5. UNDER VOLTAGE DISABLED

11002 FRAME
709823

10 9 8 7 6 5 4

6 5 4 3 2 1

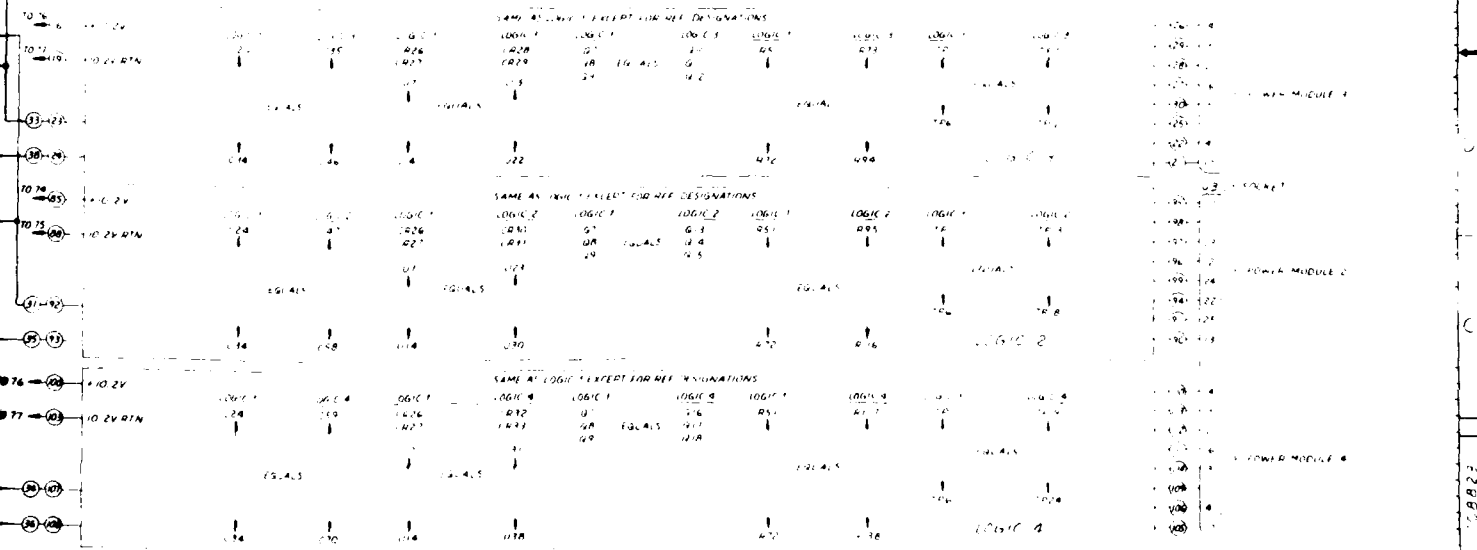

- NOTES UNLESS OTHERWISE SPECIFIED**
1. ALL RESISTOR VALUES ARE OHMS, 1%, 1/8W
 2. ALL CAPACITOR VALUES ARE IN MICROFARADS, 10%
 3. U10, U12, U18, U20, U26, U28, U14 AND U16 ARE SN74ALS00J
 4. REFERENCE DRAWINGS: UNIT SCHEMATIC, ASGRAM 108800
- [5] DISCONNECT UNDER 10.0 VOLT IN-CIRCUIT VOLTAGE (ICV) TEST

REFERENCE DESIGNATIONS	
LAST USED	DELETED
U10	0
U11	0
U12	0
U14	0
U16	0
U18	0
U20	0
U26	0
U28	0

PARTS LIST		REVISIONS	
QTY	DESCRIPTION	NO.	DATE
1	RESISTOR	1	11/82
1	CAPACITOR	2	11/82
1	IC	3	11/82
1	IC	4	11/82
1	IC	5	11/82
1	IC	6	11/82
1	IC	7	11/82
1	IC	8	11/82
1	IC	9	11/82
1	IC	10	11/82
1	IC	11	11/82
1	IC	12	11/82
1	IC	13	11/82
1	IC	14	11/82
1	IC	15	11/82
1	IC	16	11/82
1	IC	17	11/82
1	IC	18	11/82
1	IC	19	11/82
1	IC	20	11/82
1	IC	21	11/82
1	IC	22	11/82
1	IC	23	11/82
1	IC	24	11/82
1	IC	25	11/82
1	IC	26	11/82
1	IC	27	11/82
1	IC	28	11/82
1	IC	29	11/82
1	IC	30	11/82
1	IC	31	11/82
1	IC	32	11/82
1	IC	33	11/82
1	IC	34	11/82
1	IC	35	11/82
1	IC	36	11/82
1	IC	37	11/82
1	IC	38	11/82
1	IC	39	11/82
1	IC	40	11/82
1	IC	41	11/82
1	IC	42	11/82
1	IC	43	11/82
1	IC	44	11/82
1	IC	45	11/82
1	IC	46	11/82
1	IC	47	11/82
1	IC	48	11/82
1	IC	49	11/82
1	IC	50	11/82
1	IC	51	11/82
1	IC	52	11/82
1	IC	53	11/82
1	IC	54	11/82
1	IC	55	11/82
1	IC	56	11/82
1	IC	57	11/82
1	IC	58	11/82
1	IC	59	11/82
1	IC	60	11/82
1	IC	61	11/82
1	IC	62	11/82
1	IC	63	11/82
1	IC	64	11/82
1	IC	65	11/82
1	IC	66	11/82
1	IC	67	11/82
1	IC	68	11/82
1	IC	69	11/82
1	IC	70	11/82
1	IC	71	11/82
1	IC	72	11/82
1	IC	73	11/82
1	IC	74	11/82
1	IC	75	11/82
1	IC	76	11/82
1	IC	77	11/82
1	IC	78	11/82
1	IC	79	11/82
1	IC	80	11/82
1	IC	81	11/82
1	IC	82	11/82
1	IC	83	11/82
1	IC	84	11/82
1	IC	85	11/82
1	IC	86	11/82
1	IC	87	11/82
1	IC	88	11/82
1	IC	89	11/82
1	IC	90	11/82
1	IC	91	11/82
1	IC	92	11/82
1	IC	93	11/82
1	IC	94	11/82
1	IC	95	11/82
1	IC	96	11/82
1	IC	97	11/82
1	IC	98	11/82
1	IC	99	11/82
1	IC	100	11/82

5. MECHANICAL DESIGN.

Figure 4 shows the DC to DC Power Processor in the open position with its handling fixture. The mechanical subassembly consists of:

- Front Panel.
- Control Electronic Board.
- 2 Power Modules (left side).
- 2 Power Modules (right side).
- Rear Panel.

Figure 5 shows the Front Panel. Input power control is on the left, and output control is on the right.

Input control consists of:

- Input Circuit Breaker.
- Power ON Indicator Light.
- Fuse plus spare for control power.

Output control consists of:

- Output DC Circuit Breaker.
- DC Voltage/DC Current Meter.
- Meter Select Switch.
- Output Voltage Adjust Potentiometer.
- Output Current Adjust Potentiometer.

Figure 6 shows the Rear View of the Front Panel. It shows wiring of components.

The interface between the Front Panel and the side panels has a machined surface in order to increase the thermal resistance to the front panel, to allow it to operate cooler than the remainder of the mechanical assembly.

Figure 7 shows the Control Electronic Assembly. It is mounted to the hinged top cover of the DC-DC Power Processor.

The Control Electronic Assembly contains in the control electronics DC-DC Converter, the 5V regulator, and the balance of the low level control electronics.

5. MECHANICAL DESIGN - (cont'd)

Figure 8 shows the Left Side Power Stage which contains two of the four power modules.

Figure 9 shows a close-up of the Back Side of the Rear Panel. In view, are the four inductors of the input filter, the connector and EMI filters.

Figure 10 shows the Rear Panel with the mating connectors.

Figure 11 shows the DC to DC Power Processor completely assembled.

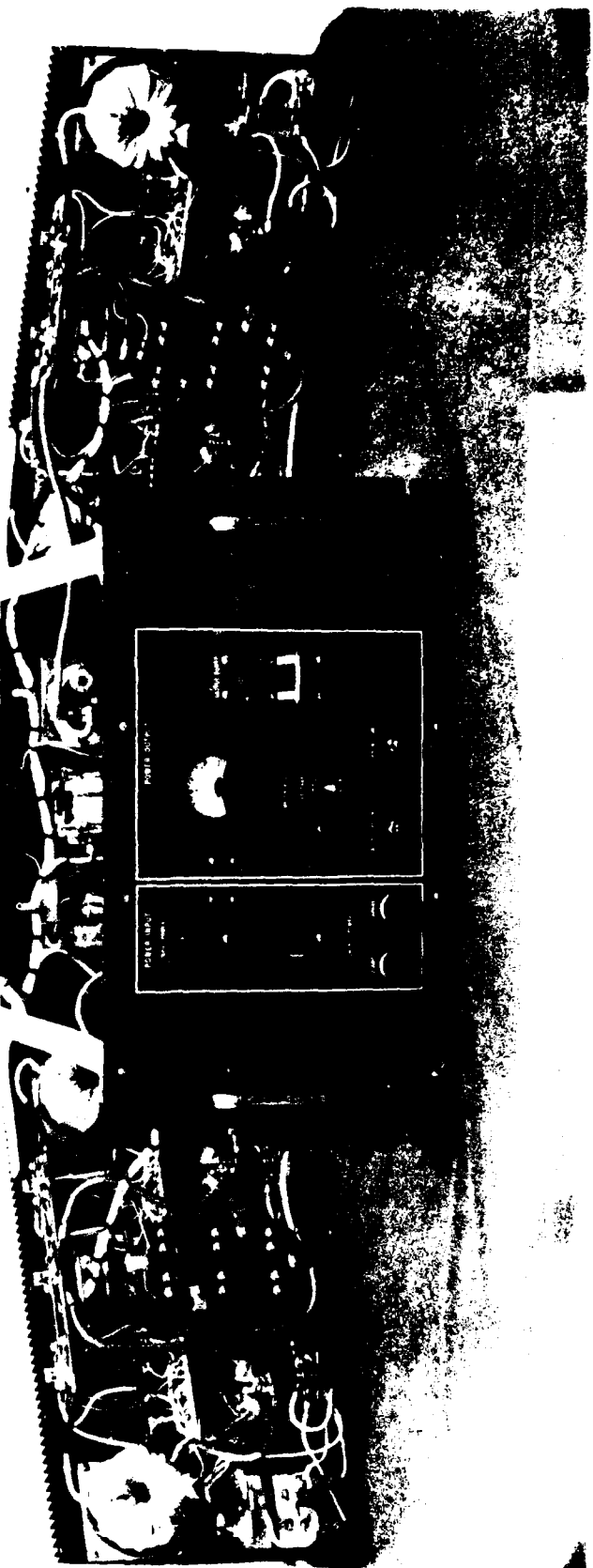
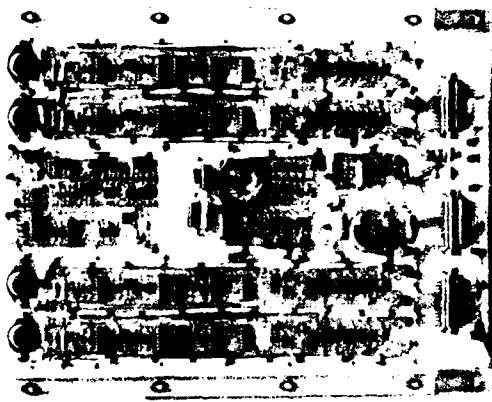

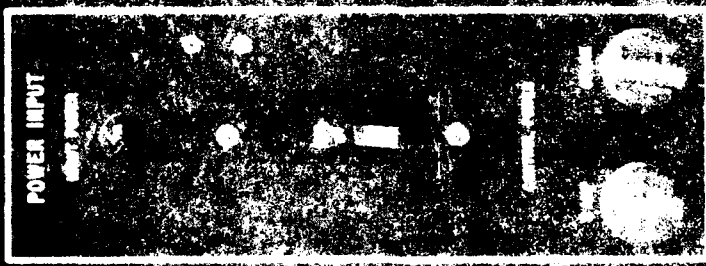
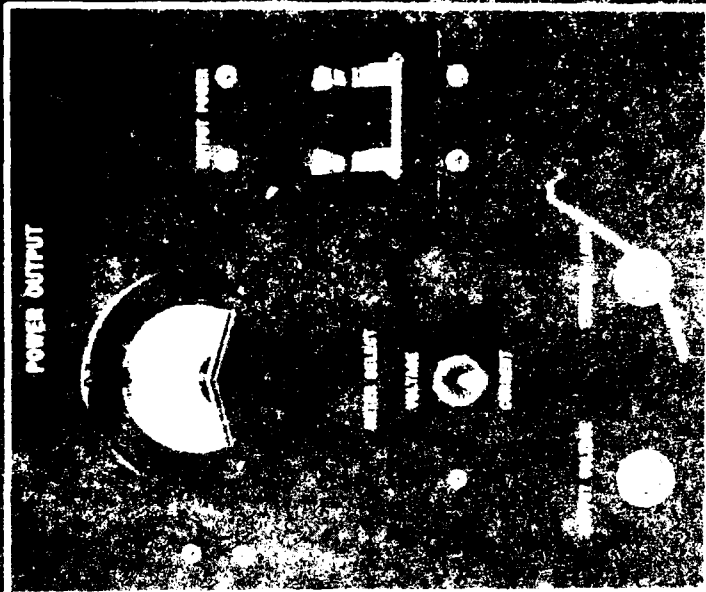

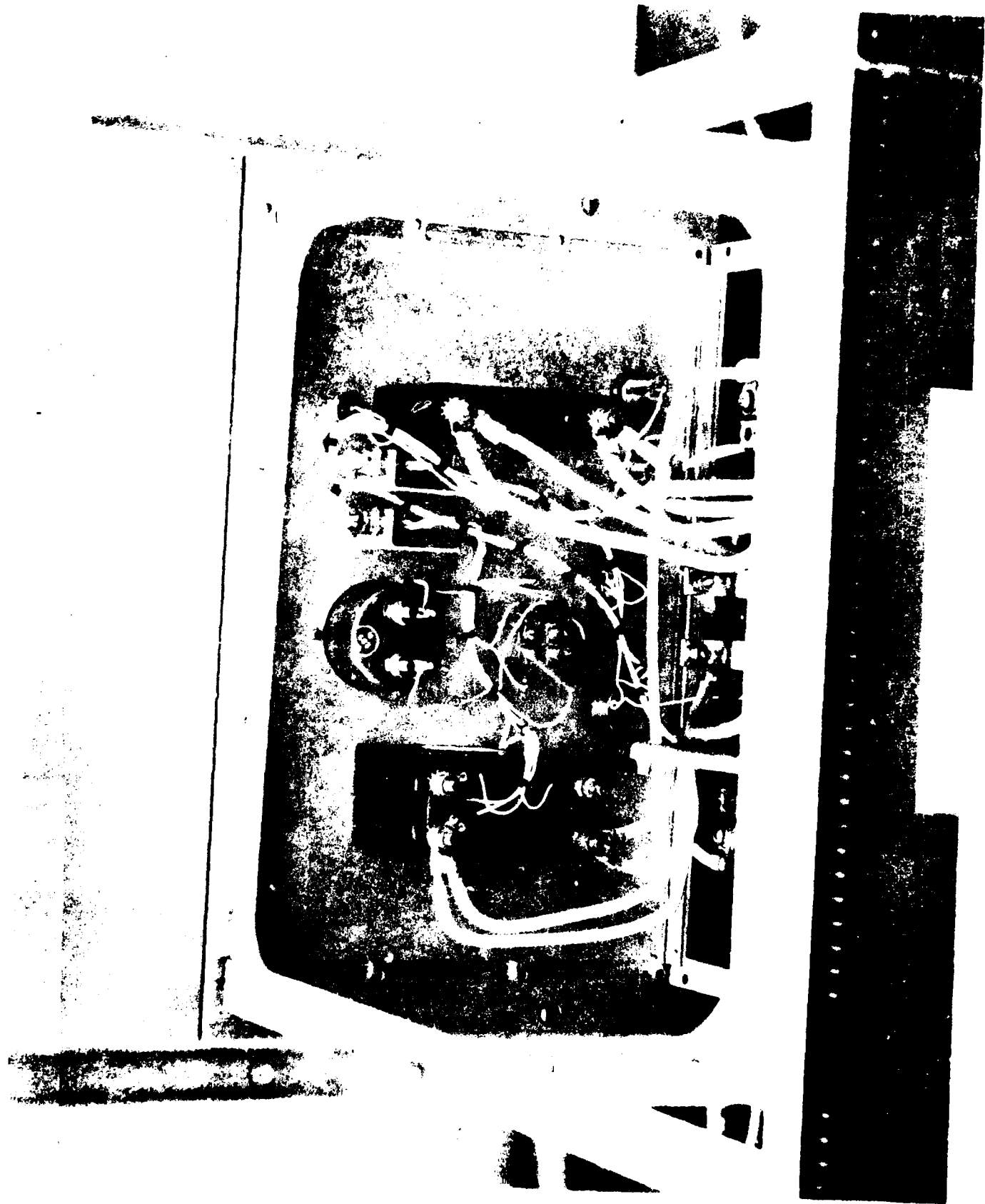

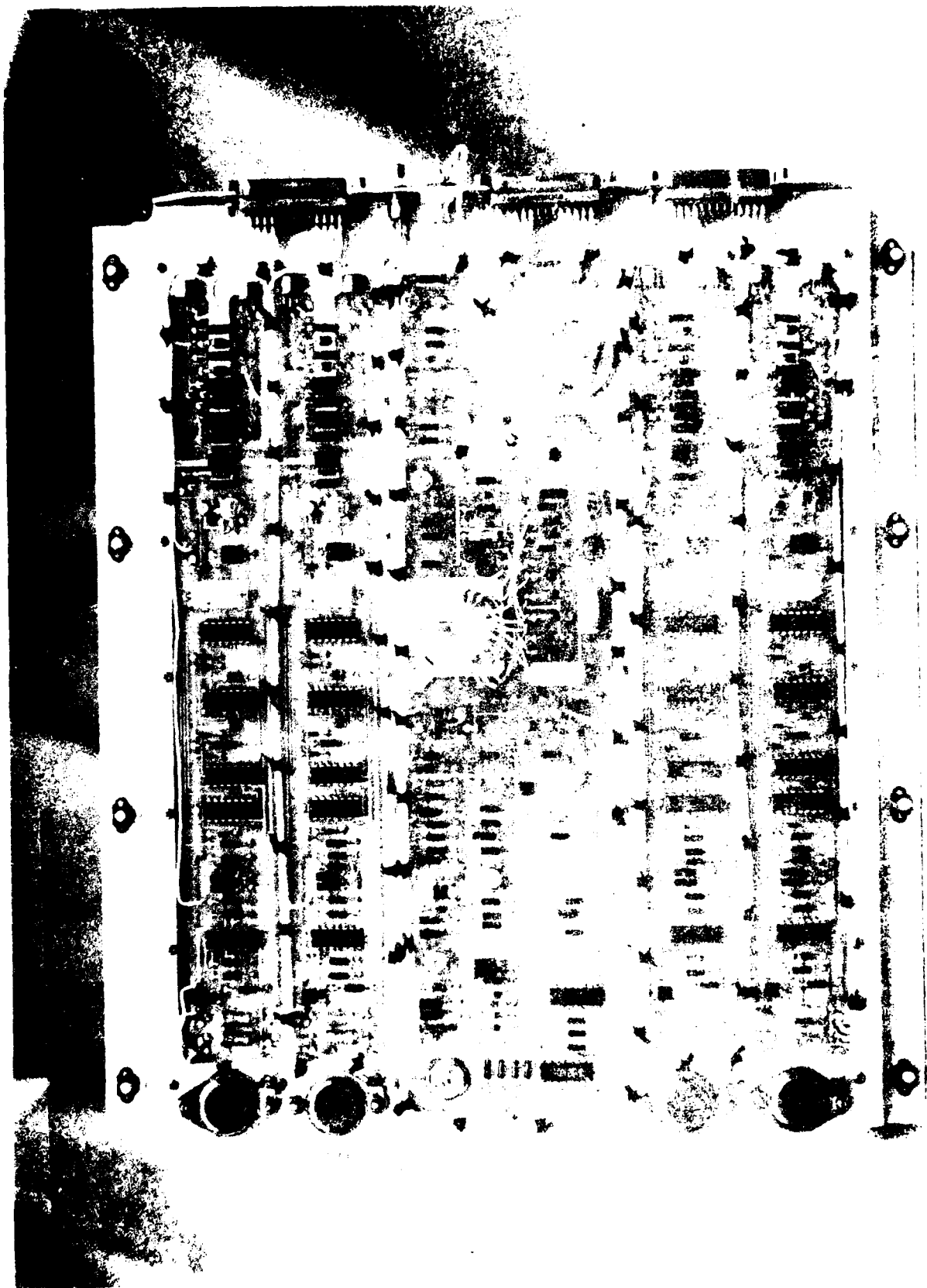

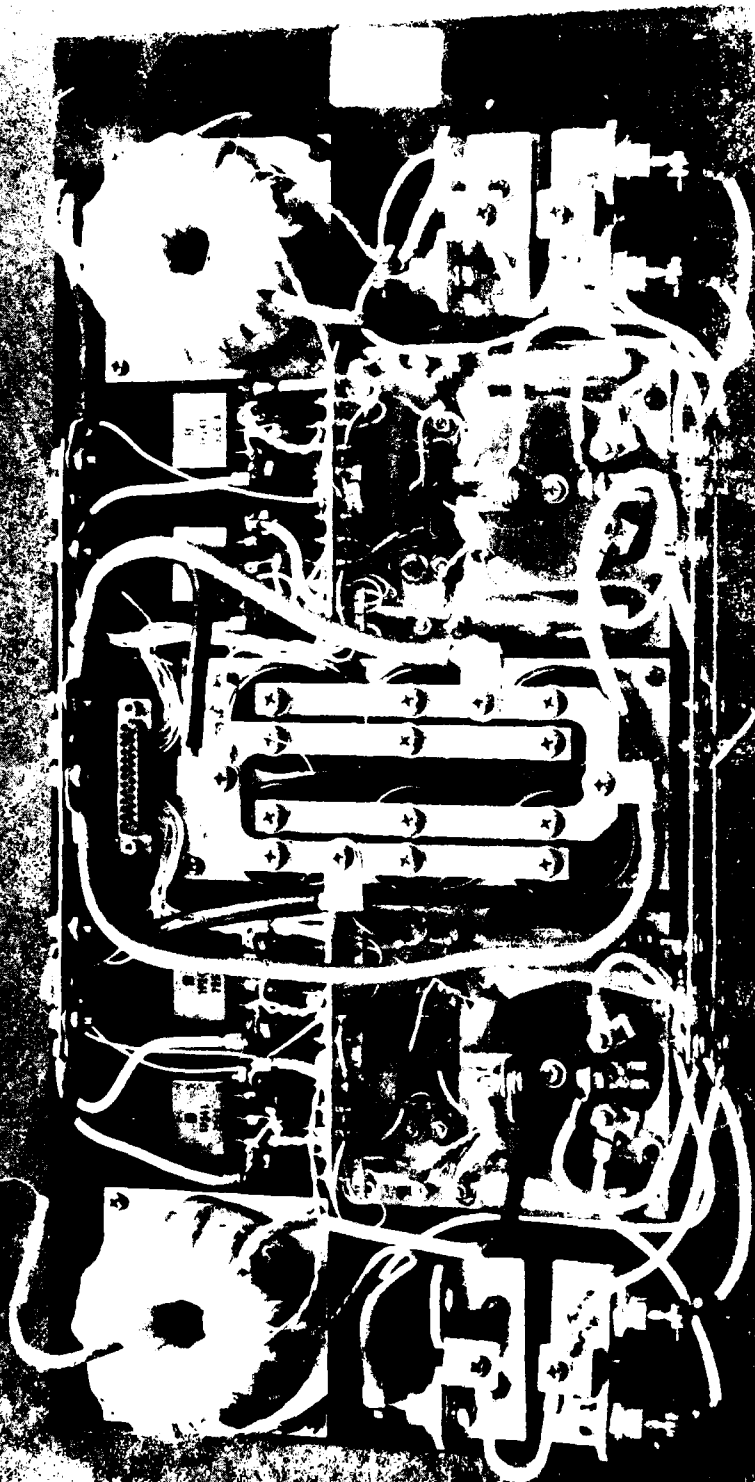

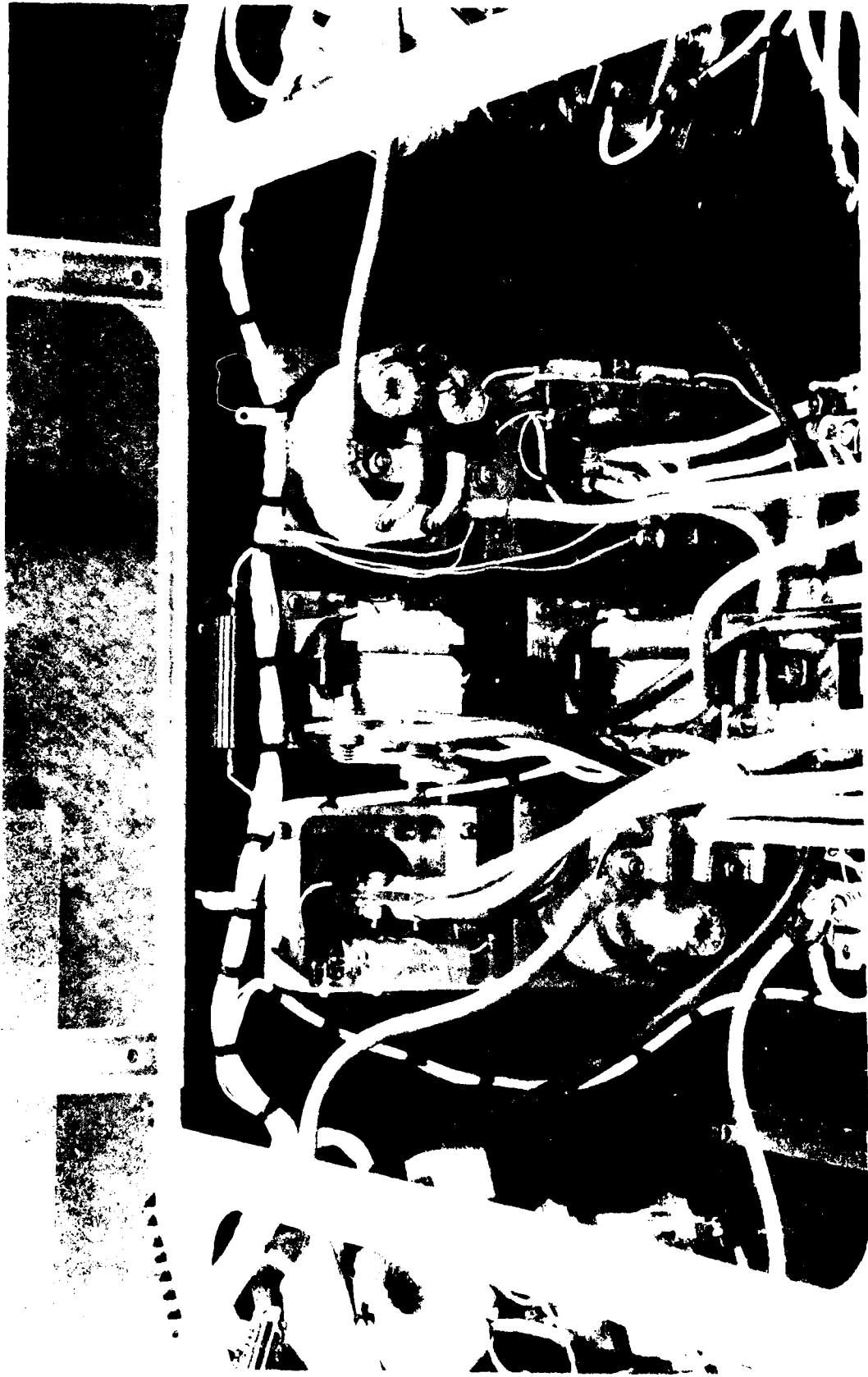

POWER PLANT
LEVEL THREE
CROSS SECTION

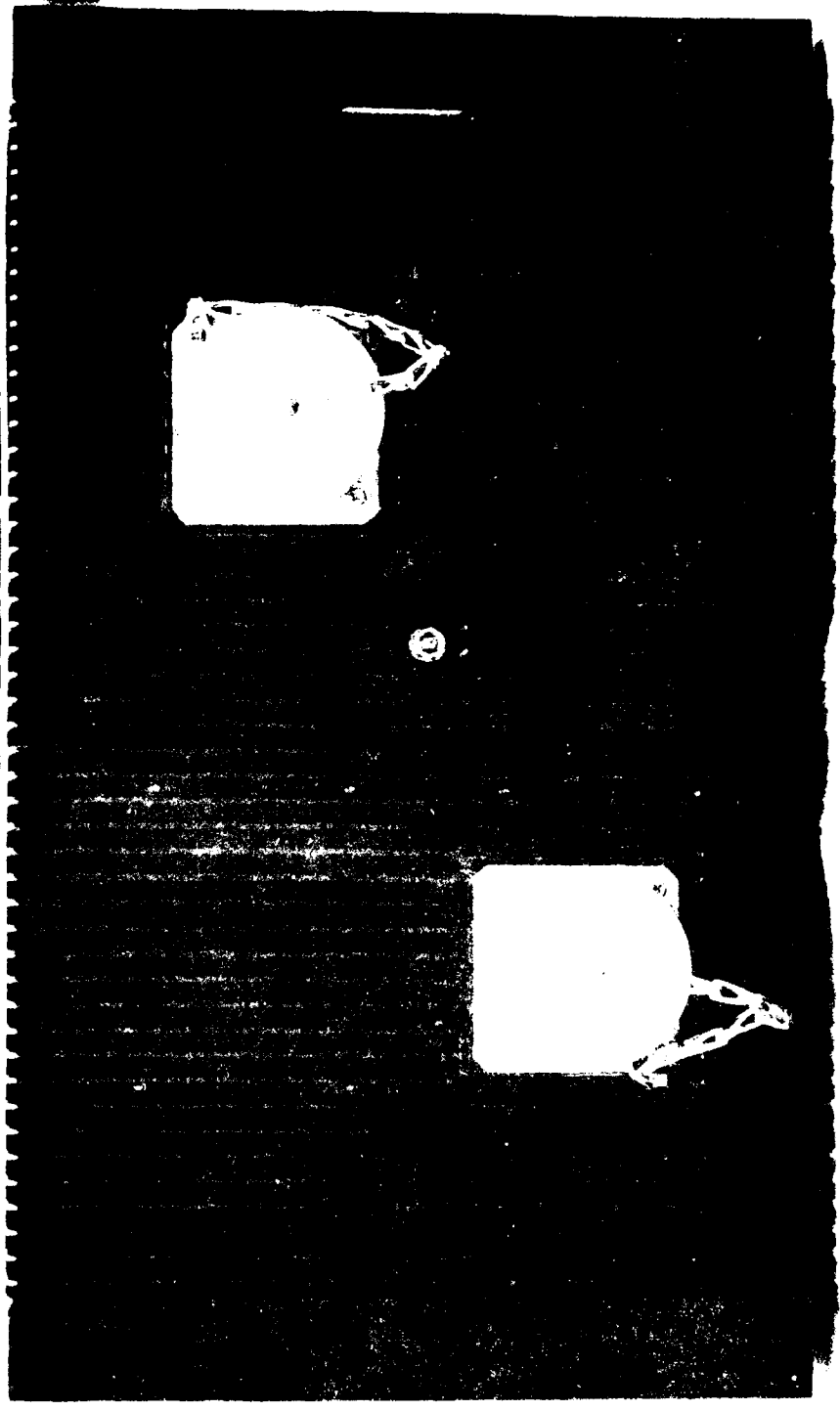

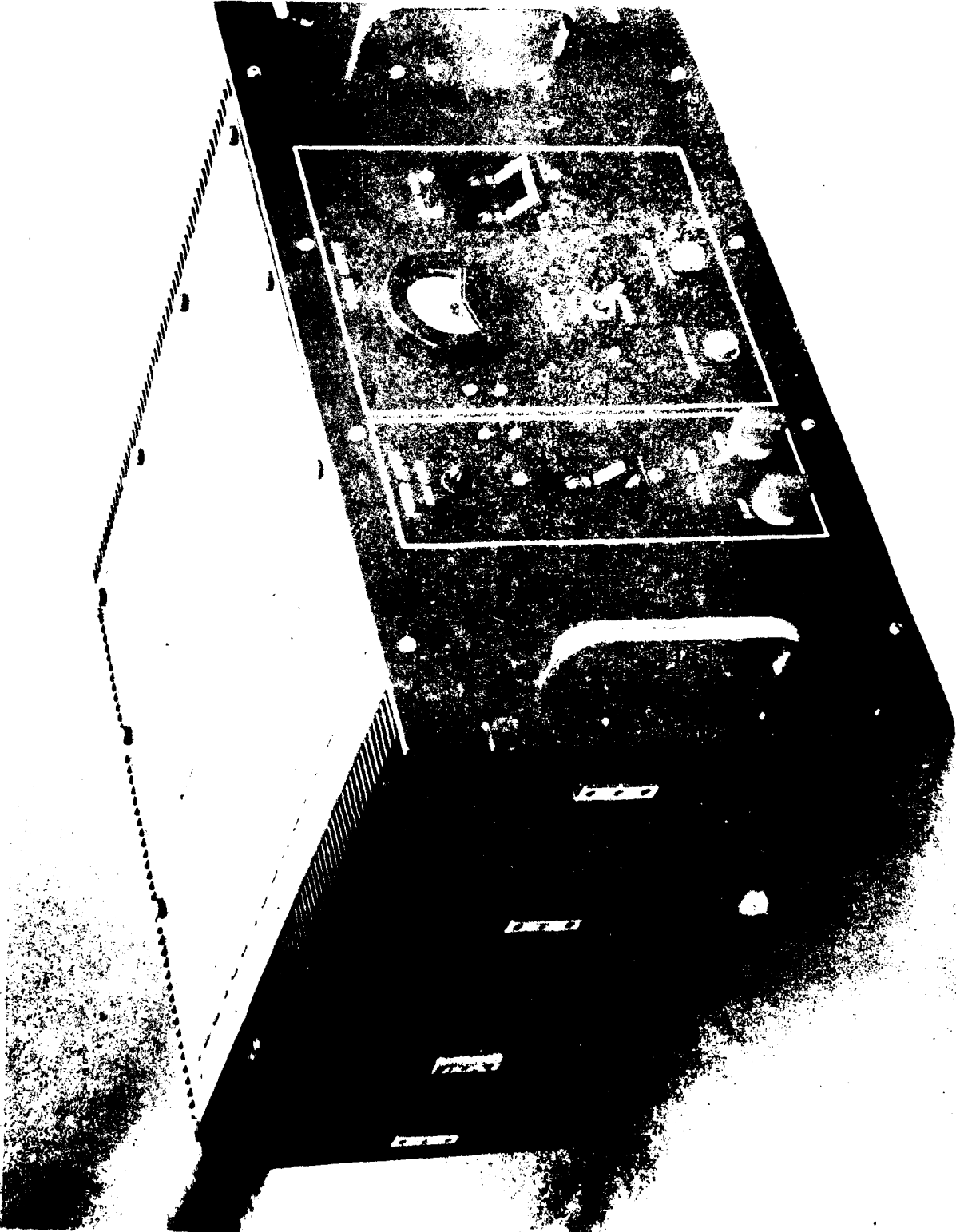

6. TEST RESULTS.

The DC-DC Power Processor models were fully tested. The following sections summarize these test results and is grouped into the following three sub-sections:

- Electrical Performance
- Thermal Control
- Electromagnetic Interference

7. INSTRUMENTATION.

A load bank was constructed (See Figure 12 for Schematic) to be used in testing the DC to DC Power Processor.

The test set-up for a typical test is shown below.

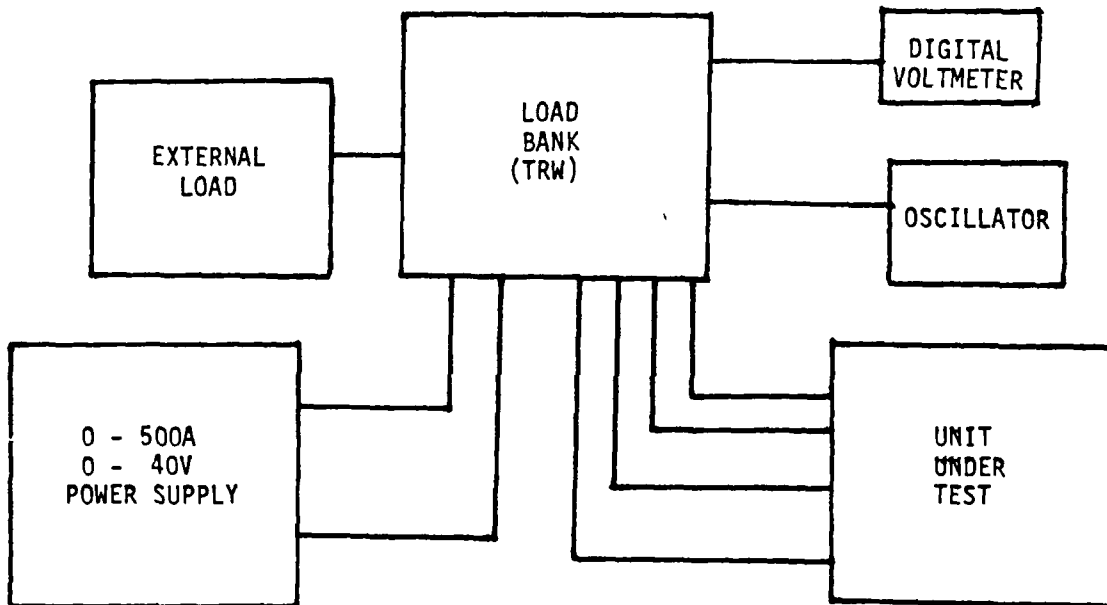

Power Supply - SORENSEN #DCR40-500
Digital Voltmeter - CIMRON Model #7200A, FAIRCHILD Model #7000
Oscillator - TEKTRONIX Model #7904, 7A26, 7B92, 7B80
Plug-in Units.

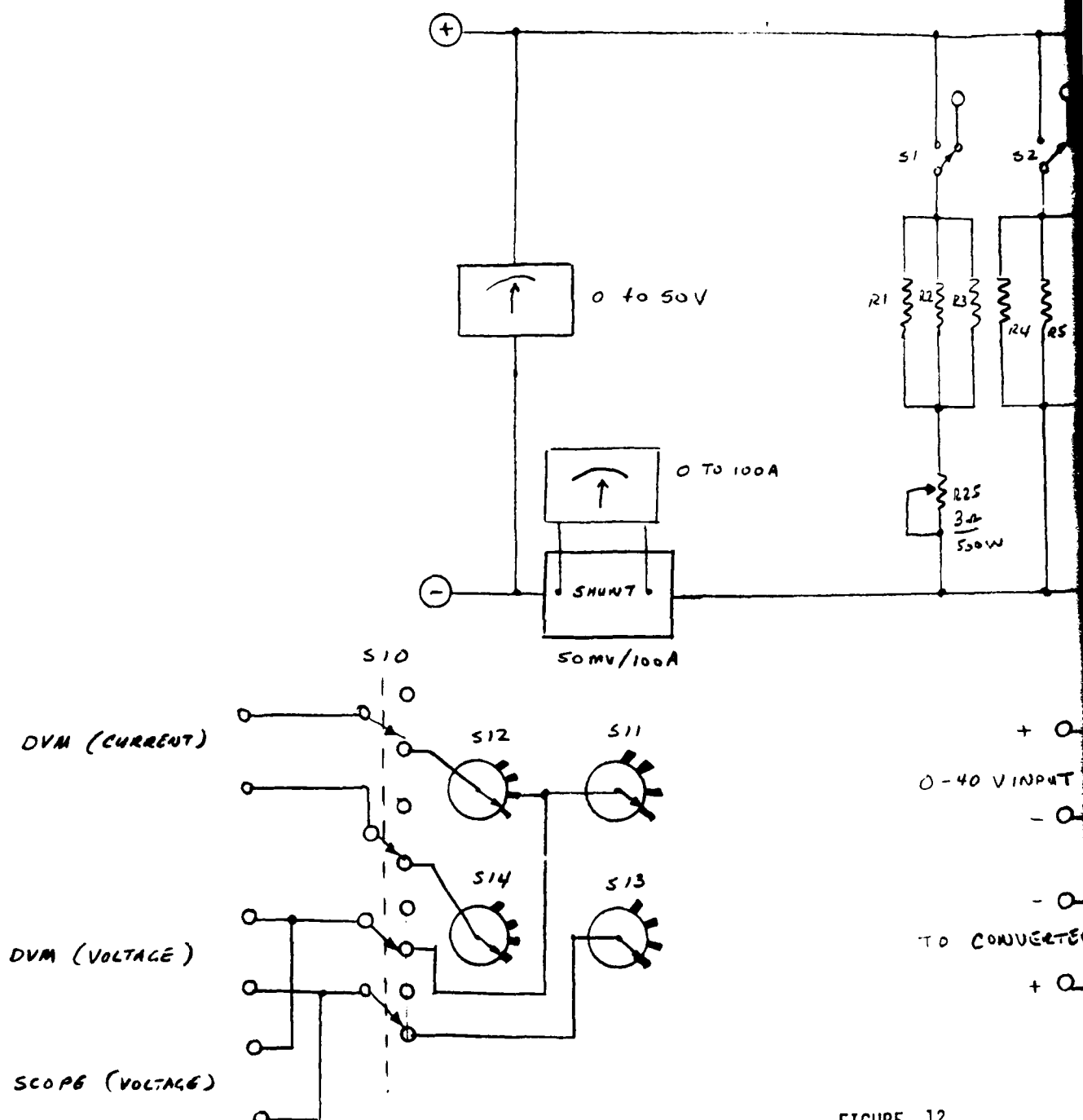
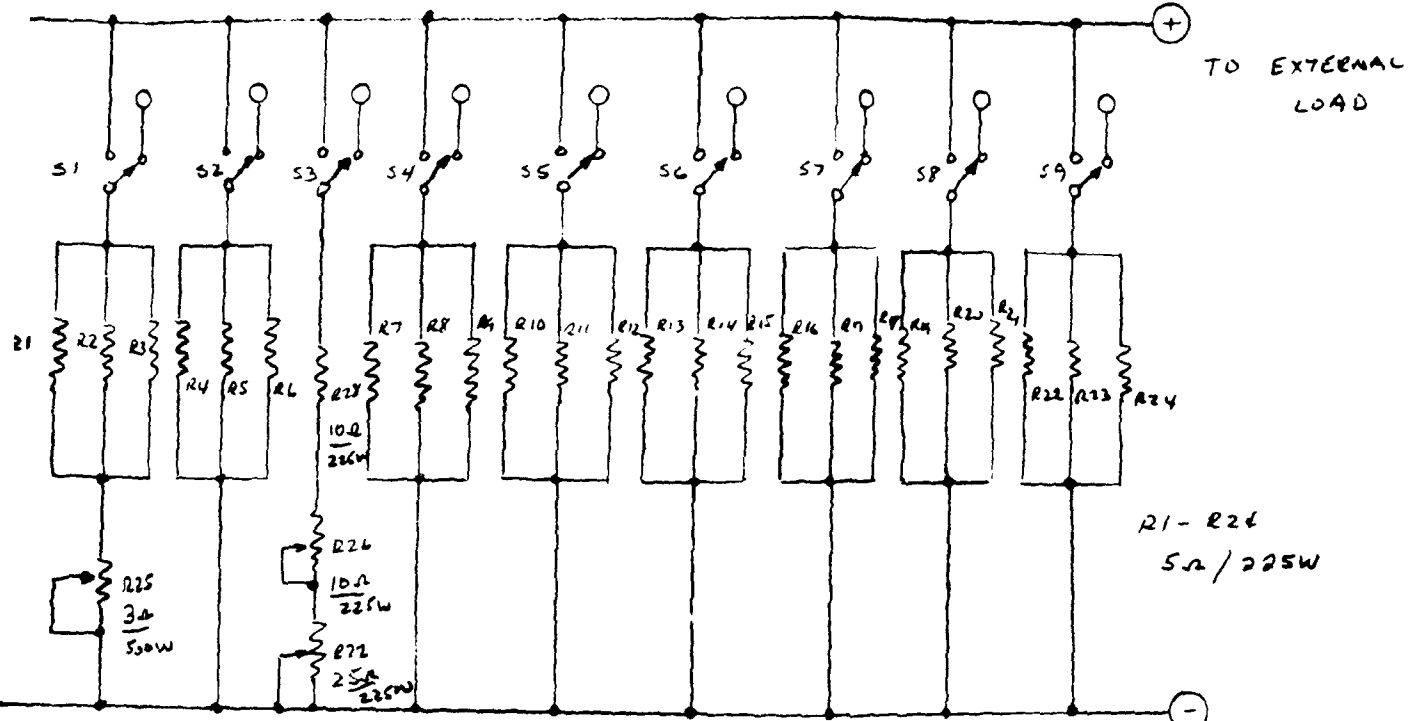

FIGURE 12

SK

REVISIONS

LTR	DESCRIPTION	DATE	APPROVED
-----	-------------	------	----------



V (INPUT)
0 - 50V AC



I (INPUT)
0 - 150A DC

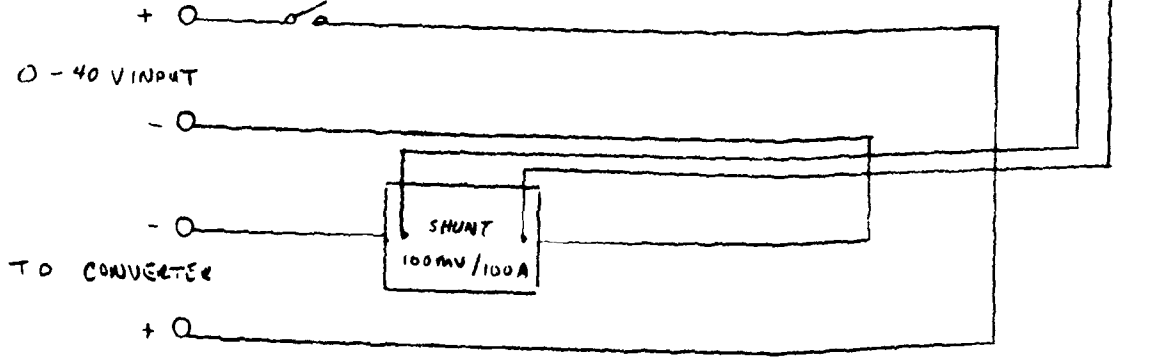

IRE 12

ENGINEERING SKETCH		TRW SYSTEMS GROUP ONE SPACE PARK • REDONDO BEACH, CALIFORNIA	
ORIGINATOR	DATE	2.4 KW DC TO DC POWER PROCESSOR LOAD BANK	
		SIZE	CODE IDENT NO.
		B	11982
MJO		SK	
SCALE		SHEET 1 OF	

-39-

Other Items of Test Equipment Used in this evaluation are listed below:

- External load with relay for over load short circuit testing.
- FLUKE 931V RMS DIFFERENTIAL VOITMETER.
- HP Model 3465 Digital Multimeter.
- TEKTRONIX Model P6042 Current Probe.
- HP Model 310A Wave Analyzer.
- TEKTRONIX Model P6019 Current Probe.
- LEEDS & NORTHROP Model 8692-2 Temperature Potentiometer.
- TENNEY ENG. Model TT6-112350 Temperature Chamber.

8. DISCUSSION OF TEST RESULTS AND RECOMMENDATIONS.

Results obtained from testing of the two DC to DC Power Processors are discussed below.

- 1) Steady-State Performance. The test results show excellent performance in output voltage regulation, ripple, and current limiting.
- 2) Transient Response. Good transient response, control of inrush current limiting during starting and output short circuit were demonstrated. Also shown was, that Component Stress levels were controlled during turn-on, steady-state, and transient load and line conditions.
- 3) Thermal Control. The continuous duty and temperature tests indicated good thermal control of the front panel temperature as well as individual component temperatures.

9. CONCLUSIONS.

The DC-DC Power Processor test program demonstrated that the units met internal component transient control and that all transient and steady-state performance data met the Technical Guidelines of the DAAB07-78-C-2988 contract with the exceptions of the EMI tests (see EMI test report) and the full load to no load recovery time requirement.

The temperature testing demonstrated that the power components temperatures were controlled in this mechanical design, such that under the worst case, all temperatures remained within safe limits.

10. SUMMARY OF THE TEST DATA

DC TO DC POWER PROCESSOR PERFORMANCE

a) Regulation and Efficiency

V INPUT (VDC)	I INPUT		P INPUT (WATTS)	V OUTPUT (VDC)	I OUTPUT (ADC)	RIPPLE (mVP-P)	P OUTPUT (WATTS)	EFF. (%)	VOLTAGE SETTING	CURRENT SETTING
	(ADC)	(mA AC)								
20	9.9	<5	198.0	28.00	6	100	168.78	85.2	28	5.0
28	7.5		210.0	28.01		110	168.84	80.4		5.0
40	5.4		216.0	23.01	6	160	168.14	77.8		5.0
20	55.2		1104.0	27.99	34.8	100	1000.15	90.6		35.0
28	39.3		1100.4	28.00	34.6	100	994.75	90.4		35.0
40	27.3		1092.0	28.01	34.6	120	994.75	91.1		35.0
20	128.7		2574.0	27.98	74.8	280	2216.3	86.1		75.0
28	90.6		2536.8	27.98	74.8	280	2217.8	87.4		75.0
40	63.3		2532.0	27.99	74.6	250	2212.6	87.4		75.0
20	7.5		150.0	24.00	5.2	90	125.37	83.6	24	5.0
40	3.9		156.0	24.01	5.2	150	125.42	80.4	24	5.0
20	111.9		2238	23.99	75	240	1922.3	85.9	24	75.0
40	55.4		2216	23.99	74.8	210	1917.9	86.5	24	75.0
20	6		120.0	32.03	3	100	96.27	80.2	32	5.0
40	3.3		132.0	32.04	3	150	96.3	73.0	32	5.0
20	145.5		2910.0	32.00	75	400	2524.5	86.8	32	75.0
40	71.4		2856.0	32.02	75	250	2525	88.4	32	75.0

DATE OF TEST: 8/15/80

TECHNICIAN : S.A

Test: Room Temperature

UNIT SERIAL NO. 001

AMBIENT TEMPERATURE 75°F

DC TO DC POWER PROCESSOR PERFORMANCE

a) Regulation and Efficiency

V _{INPUT} (VDC)	I _{INPUT}		P _{INPUT} (WATTS)	V _{OUTPUT} (VDC)	I _{OUTPUT} (ADC)	RIPPLE (mVP-P)	P _{OUTPUT} (WATTS)	EFF. (%)	VOLTAGE SETTING	CURRENT SETTING
	(ADC)	(mA AC)								
20	10.2	<5	204	28.08	6	20	169.2	92.9	28	5.0
28	7.5	↑	210	28.08	6	30	169.26	80.6		5.0
40	5.4		216	28.08	6	40	169.26	78.36		5.0
20	55.2	↓	1104	28.07	34.8	40	1003.63	90.9		35.0
28	39.3		1100.4	28.07	34.8	40	1003.63	91.2		35.0
40	27.6		1100.4	28.08	34.8	50	1003.53	91.2		35.0
20	12.81		2562	28.05	75	60	2232	87.1		75.0
28	90.3		2528.4	28.05	75	80	2232	88.3		75.0
40	63	<5	2520	28.05	75	100	2232	88.6		75.0

DATE OF TEST: 8/21/80

TECHNICIAN : S.A

Test: Cold Temperature -32°C

UNIT SERIAL NO. 001

AMBIENT TEMPERATURE -26°F

DC TO DC POWER PROCESSOR PERFORMANCE

a) Regulation and Efficiency

V _{INPUT} (VDC)	I _{INPUT}		P _{INPUT} (WATTS)	V _{OUTPUT} (VDC)	I _{OUTPUT} (ADC)	RIPPLE (mVP-P)	P _{OUTPUT} (WATTS)	EFF. (%)	VOLTAGE SETTING	CURRENT SETTING
	(ADC)	(mA AC)								
20	9.9	<5	198	28.04	6	35	169.02	85.4	28	5.0
28	7.2	↑	201.6	28.05	6	30	169.08	83.87		5.0
40	5.1		204	28.06	6	40	169.14	82.9		5.0
20	55.2		1104	28.04	34.6	40	997.52	90.4		35.0
28	39.3		1100.4	28.04	34.6	55	997.52	90.7		35.0
40	27.6		1104	28.05	34.6	60	997.86	90.4		35.0
20	131.4		2628	27.94	75	60	2227.5	84.8		75.0
28	92.1	↓	2578.8	27.95	74.8	90	2221.56	86.1		75.0
40	64.2	<5	2568	27.95	75	90	2228.25	86.8		75.0

DATE OF TEST: 8/20/80

TECHNICIAN : S.A.

Test: High Temperatures

UNIT SERIAL NO. 001

AMBIENT TEMPERATURE +145°F

CONTINUOUS DUTY

INPUT VDC	ADC	E_0 VDC	LOAD ADC	I_0 ADC	E_0 (VDC)				
					6 hr	8 hr	16 hr	24 hr	72hr
28	90.9	28	75	75.0	28.02		28.0		
	91.5			75.0					
	91.8			75.0				27.99	
	91.5			75.0					28.00

TEST: DC VOLTAGE VARIATION OVER 72 HR. TEST.

DATE: 9/3/80

ENGINEER: SID ADLIN

SERIAL NO. 001

TECHNICIAN: SID ADLIN

STABILITY

	INPUT		E_0	LOAD	E_0	I_0
	VDC	ADC	VDC	ADC	VDC	ADC
START OF						
24 HR.	20	0.6	28	0	28.04	0
TEST	20	61.2	↓	37.5	28.03	38.4
	20	129		75	28.01	75
	28	0.6		0	28.05	0
	28	43.5		37.5	28.03	38.4
	28	90.9		75	28.02	75
	40	0.3		0	28.05	0
	40	30.6		37.5	28.04	38.4
	40	63.6		75	28.02	75
	END OF					
72 HR.	20	0.6	28	0	28.05	0
TEST	20	61.5	↓	37.5	28.04	38.4
	20	130.5		75	28	75
	28	43.8		37.5	28.04	38.4
	28	91.5		75	28.00	75
	28	0.3		0	28.06	0
	40	0.3		0	28.06	0
	40	30.9		37.5	28.05	38.4
	40	63.9		75	28.01	75

TEST: 0 HR.

TEST END 72 HR.

DATE: 9/3/80

SERIAL NO. 001

ENGINEER: Sid Adlin

TECHNICIAN: Sid Adlin

DC TO DC POWER PROCESSOR PERFORMANCE

a) Regulation and Efficiency

V _{INPUT} (VDC)	I _{INPUT}		P _{INPUT} (WATTS)	V _{OUTPUT} (VDC)	I _{OUTPUT} (ADC)	RIPPLE (mVP-P)	P _{OUTPUT} (WATTS)	EFF. (%)	VOLTAGE SETTING	CURRENT SETTING
	(ADC)	(mA AC)								
20	9.6	<5	192	28.055	6	80	169	88.0	28	5.0
28	7.2		201.6	28.059	6	100	169	83.87		5.0
40	5.1		204	28.064	6	150	169.1	82.9		5.0
20	54.6		1092	28.045	34.5	100	996.83	91.3		35.0
28	39.0		1092	28.049	34.4	80	991.06	90.8		35.0
40	27.3		1092	28.053	34.4	120	991.06	90.8		35.0
20	129.3		2586	28.007	74.8	300	2221.56	85.9		75.0
28	90.9		2545.2	28.010	74.8	260	2221.56	87.3		75.0
40	63.6		2532	28.013	74.6	300	2216.37	87.5		75.0
20	7.2		144	24.006	5.2	80	125.32	87.0	24	5.0
40	3.9		156	24.013	5.2	140	125.32	80.4	24	5.0
20	112.2		2244	23.974	75	390	1923.75	85.7	24	75.0
40	55.2		2208	23.982	74.8	300	1919.37	86.9	24	75.0
20	5.7		114	32.05	3	100	96.3	84.5	32	5.0
40	3		120	32.06	3	160	96.3	80.3	32	5.0
20	145.3		2916	32.01	75	300	2526.75	86.7	32	75.0
40	71.4		2956	32.01	75	300	2528.25	88.5	32	75.0

DATE OF TEST: 10/15/80

TECHNICIAN : S.A

UNIT SERIAL NO. 002

AMBIENT TEMPERATURE +77°F

OVERSHOOT AND RECOVERY

INITIAL CONDITIONS		TERMINAL CONDITIONS		OVERSHOOT ABOVE 28. 28VDC INPUT VDC			RECOVERY M-SEC TO 28 VDC INPUT VDC		
E_0 (VDC)	I_0 (ADC)	E_0 (VDC)	I_0 (ADC)	20	28	40	20	28	40
0	0	28	75	0	0	0	0	0	0
0	0	28	0	0	0	0	0	0	0
28	0	28	75	-1 volt	-1 volt	-1 volt	1	1	1
28	75	28	0	+0.52	+0.52	+0.52	5000	5000	5000

TEST: LOAD & LINE VARIATION

DATE: 10/20/80

SERIAL NO. 002

ENGINEER: Sid Adlin

TECHNICIAN: Sid Adlin

OVERSHOOT AND RECOVERY

INITIAL CONDITIONS		TERMINAL CONDITIONS		OVERSHOOT ABOVE 28. 28VDC INPUT VDC.			RECOVERY M-SEC TO 28 VDC INPUT VDC		
E_0 (VDC)	I_0 (ADC)	E_0 (VDC)	I_0 (VDC)	20	28	40	20	28	40
0	0	28	75	0	0	0	0	0	0
0	0	28	0	0	0	0	0	0	0
28	0	28	75	(-2.0) 0	(-2.0) 0	(-2.0) 0	2	2	2
28	75	28	0	+1.72	+1.72	+1.72	17000	17000	1700

TEST: LOAD & LINE VARIATION

DATE: 10/20/80

SERIAL NO. 002

ENGINEER: Sid Adlin

TECHNICIAN: Sid Adlin

NOTE: Readings taken 25' from unit (Remote Sense).

ACCELERATED STRESSES

Time On	V _{Input}	Time Off	Failures	Degradation
9:18 AM	41.34	9:35	None	None

Test Engineer: Sid Adlin

Date: 10/20/80

Technician: Sid Adlin

Serial No. 02

OVER LOAD PROTECTION

INPUT VDC	TEMP	READING	OUTPUT CURRENT						
			OUTPUT VOLTAGE ± 0.1 VDC						
			32	28	24	18	12	6	2.5
28	AMB	1	75.6	79.6	79.6	79.6	79.6	79.6	79.6
20		2	75.6	79.6	79.6	79.6	79.6	79.6	79.6
40		3	75.6	79.6	79.6	79.6	79.6	79.6	79.6

ENGINEER: S. Adlin S/N 002

TEST: 10/20/80

8-15-80

DC TO DC POWER PROCESSOR

+28V OUTPUT REGULATION

V_{IN} 20-40V

op

+1.0

+0.8

+0.6

+0.4

+0.2

0

-0.2

-0.4

-0.6

-0.8

-1.0

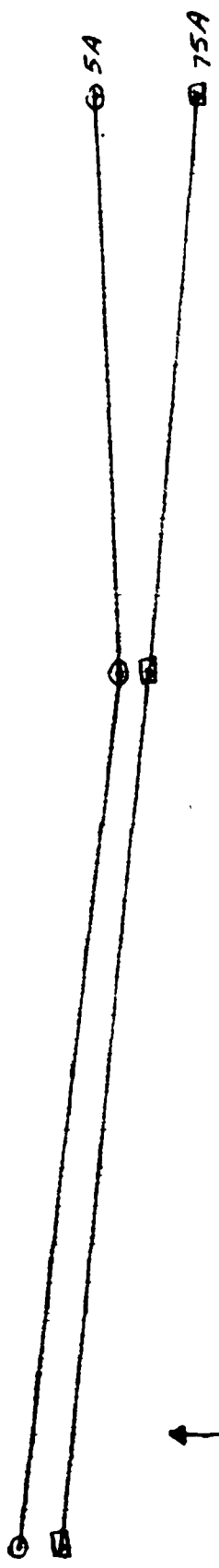

↑
OUTPUT
DEVIATION
(%)

REMOTE SENSE

TEMPERATURE →
(°C)

-32°C

-25
+25°C

+63°C

DC TO DC POWER PROCESSOR 8-20-80
 EFFICIENCY VS POUT WITH TEMPERATURE

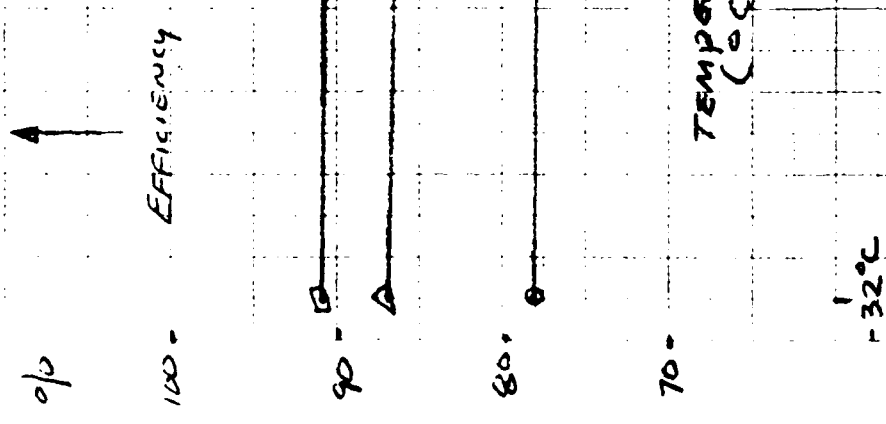

○ P_o 169W
 □ P_o 1KW
 △ P_o 2.2KW

8-15-80

DC TO DC POWER PROCESSOR EFFICIENCY VS POWER OUT (AMBIENT TEMP)

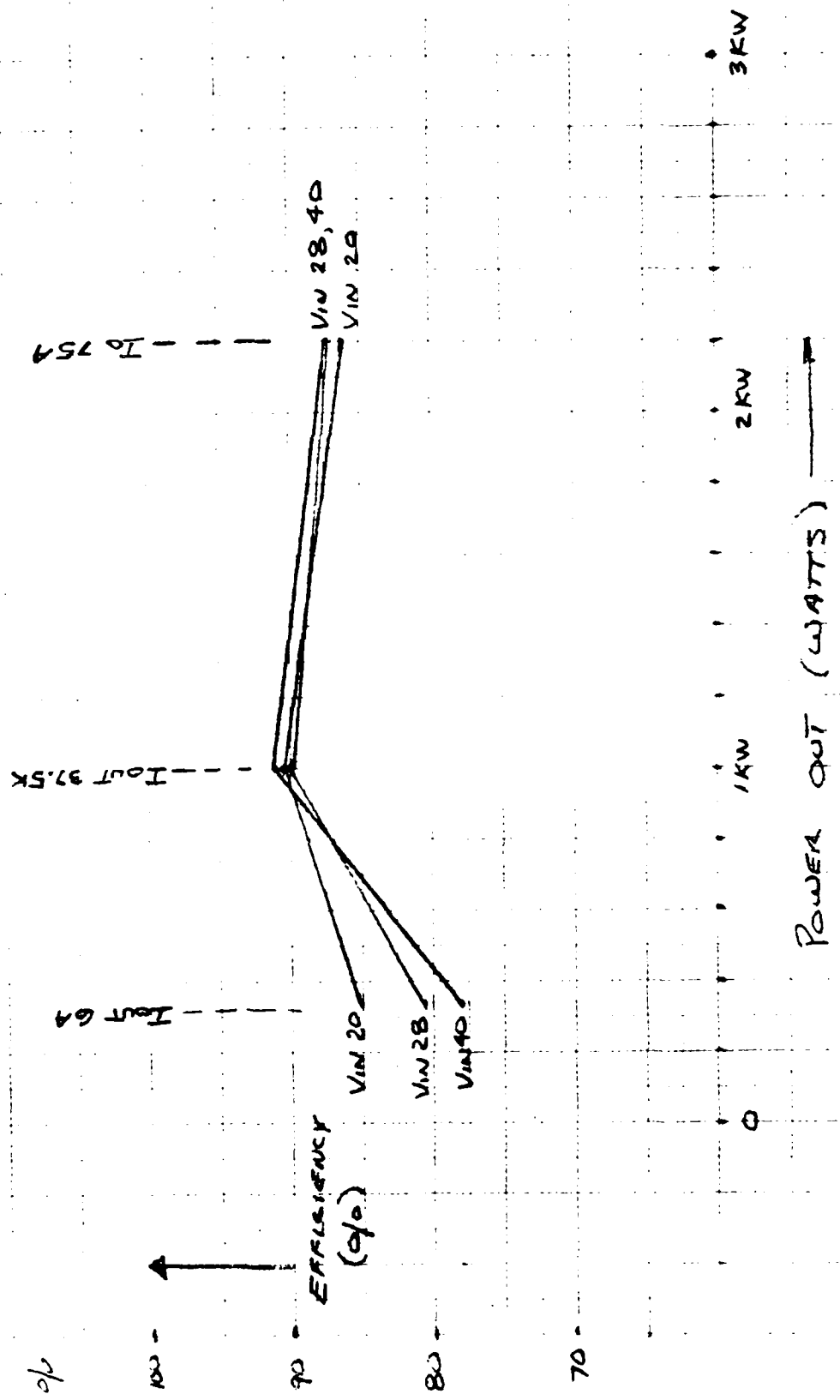

Temperature Profile

A temperature test was performed in which fifteen internal temperatures were monitored. The results of these tests are summarized in tables II-1A thru II-1C.

Note: That at room ambient temperature, the outside front panel temperature reached 104°F (40°C) as compared to the 43°C maximum requirement as contained in the design guidelines.

TABLE II-1A (V_{IN}^{28} , V_0^{28} , I_0^{75A})
 DC to DC Power Processor Temperature Profile at 77°F Ambient
 (Component and Unit Temperatures at end of 72 hour test)

T.C. NO.	LOCATION	TEMP °F
1	Outside Ambient	77
2	Outside-Front Panel	104
3	Outside-Left Side-Opposite Front Rectifiers	139
4	Outside-Left Side-Adjacent Front Transistors	150
5	Outside-Right Side-Opposite back Rectifiers	136
6	Transformer-Left Side Body Front	178
7	PC Board Surface-Middle fiber board	157
8	Input Filter Capacitor-Floor bracket middle	135
9	Output Filter Capacitor-Floor Bracket Right	137
10	Right Side Front Rectifier case-Bracket for two	163
11	Left Side Transistor Case-Front	160
12	Air just below PC Board.	150
13	Flyback Inductor Front Body	169
14	Rear Panel Middle	126
15	Input Inductor on Body-Top	155

TABLE II-1B (V_{IN}^{28} , V_0^{28} , I_0^{75A})
 DC-DC Power Processor Temperature Profile at $T_{AMB}=145^\circ\text{F}$
 (Component and Unit Temperatures After Stabilization)

T.C. NO	LOCATION	TEMP °F
1	Outside Ambient	145
2	Outside-Front Panel	145
3	Outside-Left Side-Opposite Front Rectifiers	157
4	Outside-Left Side-Adjacent Front Transistors	178
5	Outside-Right Side-Opposite back Rectifiers	167
6	Transformer-Left Side Body Front	206
7	PC Board Surface-Middle fiber board	185
8	Input Filter Capacitor-Floor bracket middle	161
9	Output Filter Capacitor-Floor Bracket Right	162
10	Right Side Front Rectifier case-Bracket for two	187
11	Left Side Transistor Case-Front	187
12	Air just below PC Board.	181
13	Flyback Inductor Front Body	200
14	Rear Panel Middle	163
15	Input Inductor on Body-Top	189

TABLE II-1C ($V_{IN} 28, V_O 28, I_O 75A$)DC-DC Power Processor Temperature at $T_{AMB} = 26^\circ F$

(Component and Unit Temperatures after Stabilization)

T.C. NO	LOCATION	TEMP $^\circ F$
1	Outside Ambient	-26
2	Outside-Front Panel	-26
3	Outside-Left Side-Opposite Front Rectifiers	- 2
4	Outside-Left Side-Adjacent Front Transistors	6
5	Outside-Right Side-Opposite back Rectifiers	- 4
6	Transformer-Left Side Body Front	31
7	PC Board Surface-Middle fiber board	24
8	Input Filter Capacitor-Floor bracket middle	- 8
9	Output Filter Capacitor-Floor Bracket Right	- 8
10	Right Side Front Rectifier case-Bracket for two	23
11	Left Side Transistor Case-Front	16
12	Air just below PC Board.	12
13	Flyback Inductor Front Body	28
14	Rear Panel Middle	- 7
15	Input Inductor on Body-Top	17

OVERSHOOT AND RECOVERY

INITIAL CONDITIONS		TERMINAL CONDITIONS		OVERSHOOT ABOVE 28. 28VDC INPUT VDC			RECOVERY M-SEC TO 28 VDC INPUT VDC		
E_0 (VDC)	I_0 (ADC)	E_0 (VDC)	I_0 (VDC)	20	28	40	20	28	40
0	0	28	75	0	0	0	0	0	0
0	0	28	0	0	0	0	0	0	0
28	0	28	75	(-2V) 0	(-2V) 0	(-2V) 0	2	2	2
28	75	28	0	0.4	0.4	0.4	5000	5000	5000

TEST: LOAD & LINE VARIATION

DATE: 10/2/80

SERIAL NO. 01

ENGINEER: S. Adlin

TECHNICIAN:

NOTE: Readings taken at output connector (Local Sense).

9-26-80

0-75A STEP LOAD

$V_{\text{INPUT}} = 28\text{VDC}$

Vert = 0.5V/cm

Horiz = 5msec/cm

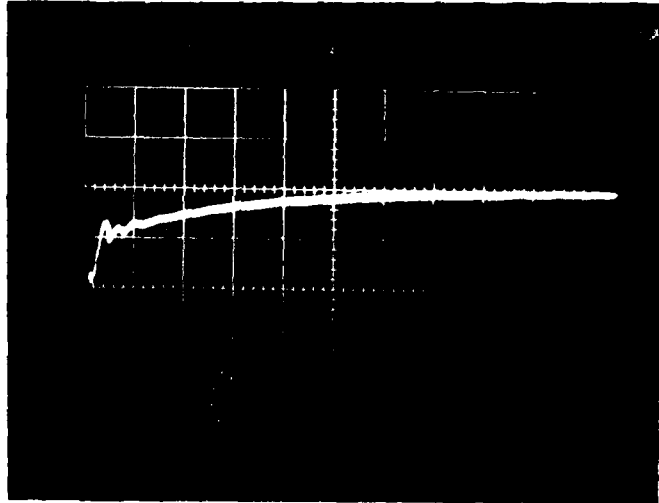

75 to 0A STEP LOAD

$V_{\text{INPUT}} = 28\text{VDC}$

Vert = 0.5V/cm

t = 20msec/cm

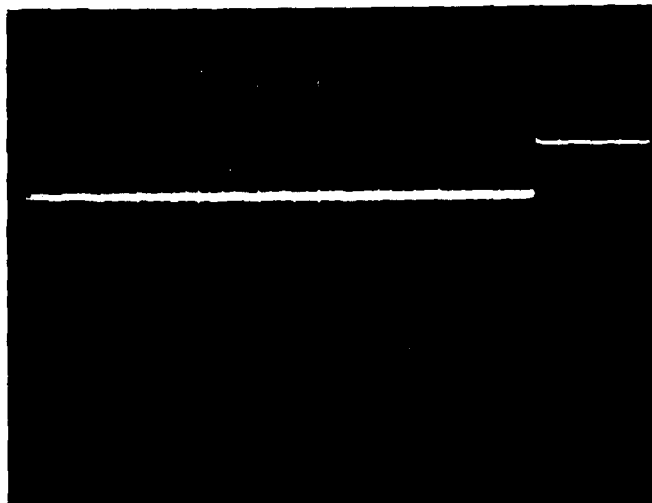

SWITCHING WAVEFORMS

V_0 28 I_0 75A

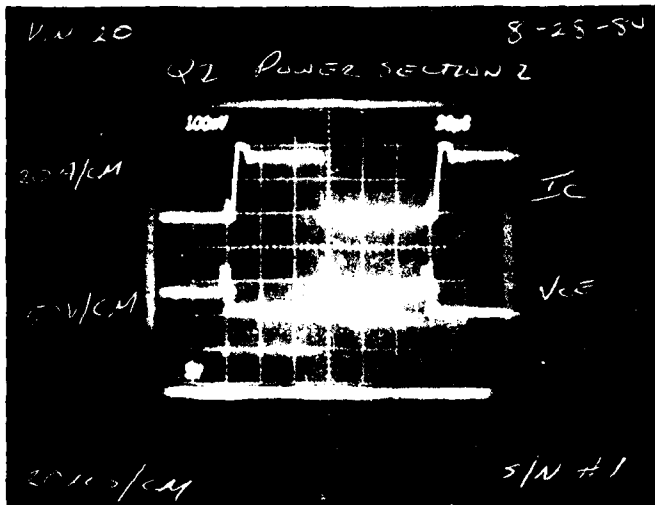

Q2 POWER XSTR
MODULE 2

I_{COL} : 20A/cm

V_{CE} : 50V/cm

20us/cm

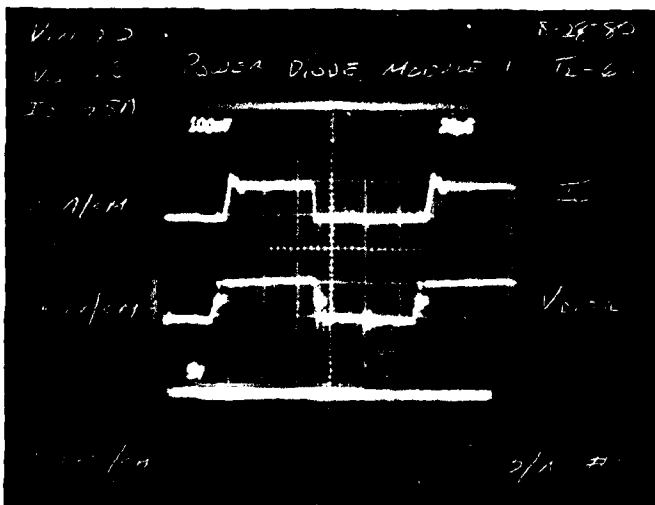

POWER DIODE
MODULE 1

I_{DIODE} : 20A/cm

V_{piv} : 50V/cm

20us/cm

VIN 20 TO 40V STEP
(TRANSIENT)

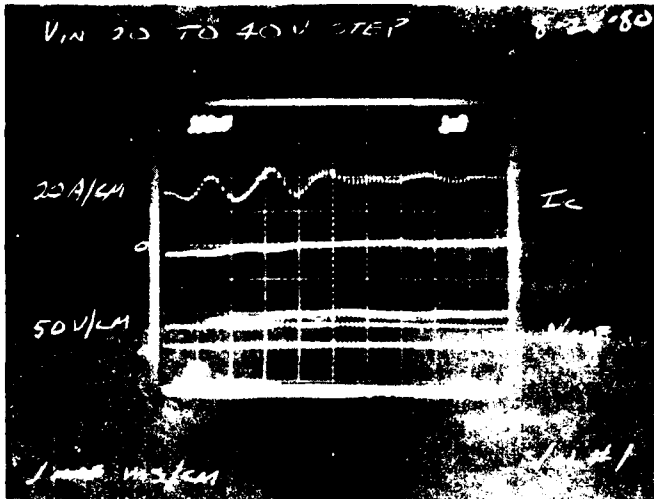

Q2 POWER XSTR
MODULE #2

I_C 20A/cm

V_{CE} 50V/cm

1ms/cm

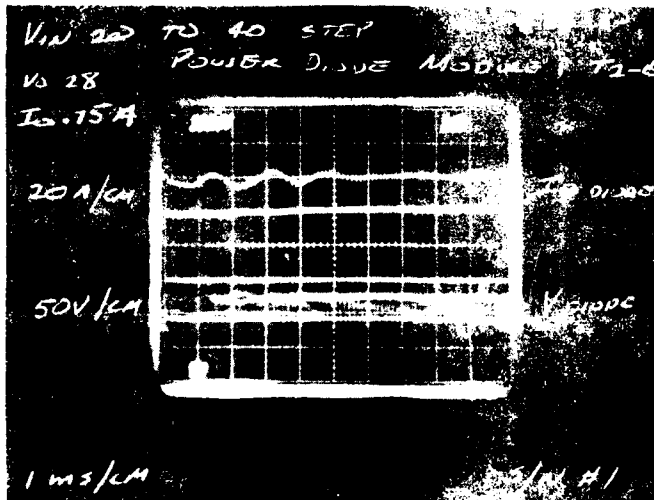

POWER DIODE
MODULE #1

$I_{O\text{DIODE}}$ 20A/cm

V_D 50V/cm

1ms/cm

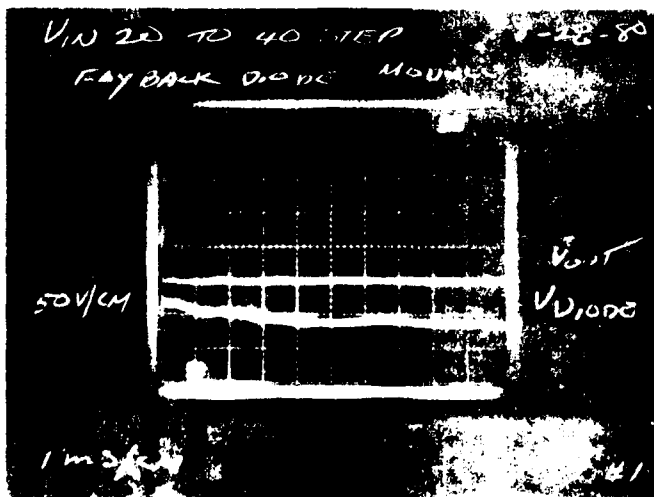

POWER DIODE
(FLYBACK)
MODULE #2

V_D 50V/cm

1ms/cm

8-28-80

4 W KNIFE ON TRANSIENT

V_{IN} 25 V, I_C 75%

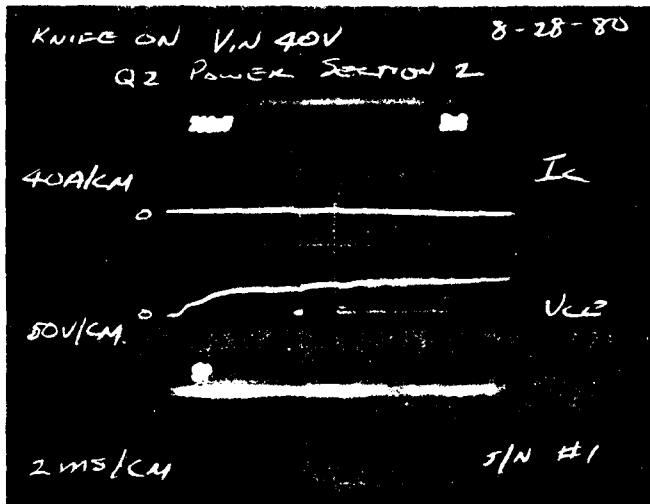

Q2 POWER XSTR
MODULE #2

I_C : 40A/cm

V_{CE} : 50V/cm

2ms/cm

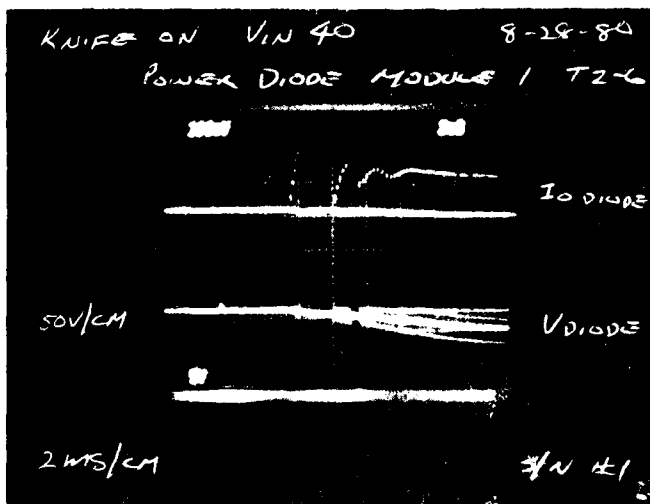

POWER DIODE
MODULE #1

I_{0DIODE} : 20A/cm

V_{piv} : 50V/cm

2ms/cm

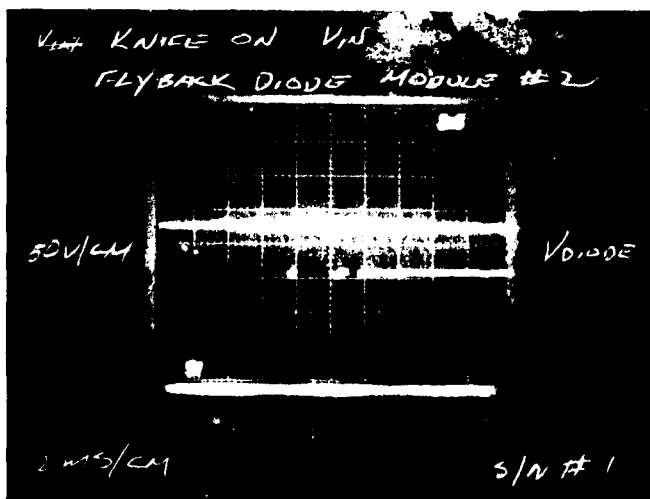

OUTPUT POWER
DIODE - MODULE #2

50V/cm

10-3-80

DC POWER PROCESSOR SG 0001

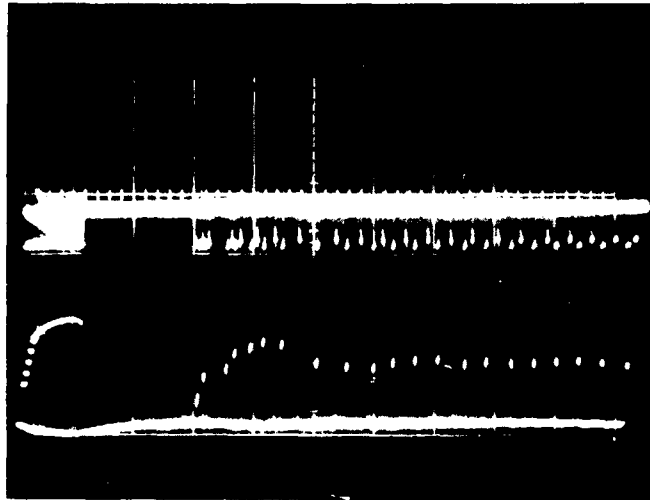

NO LOAD TO A SHORT

V_{IN} 28

V_{CE} 50V/cm

I_{COL} 40A/cm

2ms/cm

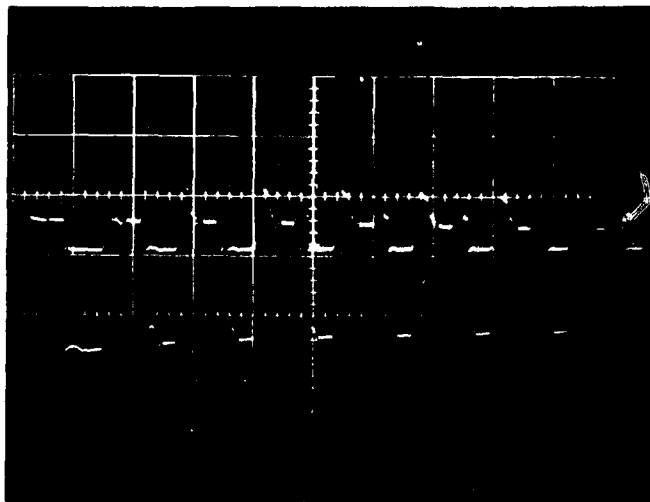

NO LOAD TO A SHORT

V_{CE} 50V/cm

I_{COL} 40A/cm

50ms/cm

V_{IN} 20 TO 40V STEP (TRANSIENT)

V_{OUT}

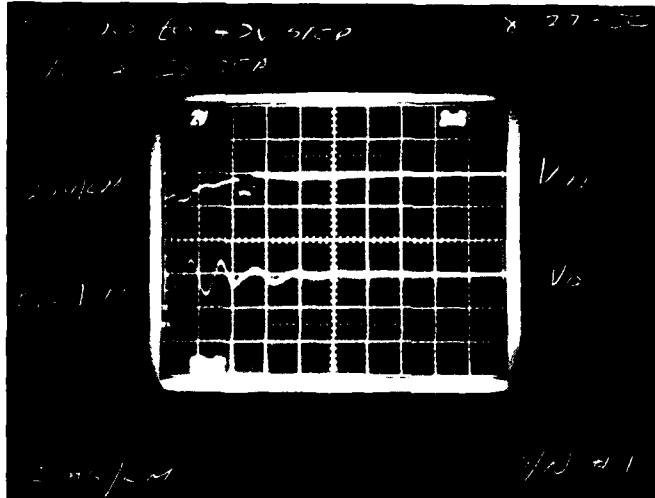

V_{IN} : 20V/cm

V_{O} : 0.5V/cm

2ms/cm

APPENDIX

Parts List

These lists contain component information and represents the parts used in the two development models.

CONFIGURATION				PARTS LIST							REV.
QTY REQD	QTY REQD	QTY REQD	PART OR IDENTIFYING NO.	CODE IDENT	NOMENCLATURE OR DESCRIPTION	SPECIFICATION OR MANUFACTURER	CKT REF	ITEM NO.			
38			LM101AH		IC (OP-AMP)		U101 U102	1			
112			SE555T		IC (TIMER)		U103	2			
10			CD4018BD		IC (COUNTER)		U104	3			
20			LM139AD		IC (VOLTAGE COMPARATOR)		U105	4			
								5			
								6			
								7			
10			1N4573A		ZENER DIODE 6.4V (TC)		VR101 VR102	8			
								9			
								10			
								11			
16			1N5811		DIODE 6A, 150V		CR101,102 103,104	12			
16			1N5806		DIODE 2.5A, 150V		CR105,106 107,108	13			
2			1N5806		DIODE 2.5A, 150V		CR109,110	14			
			1N5811				CR114,115 116,112	15			
<1			CK06BX103K		CAPACITOR, 0.1 μ f/200V		C101,109	17			

TRW
 DEFENSE AND SPACE SYSTEMS GROUP
 ONE SPACE PARK • REDONDO BEACH, CALIFORNIA
 $\Sigma P_{diff} = 629 \text{rW}$
 SIZE FSCM NO.
A 11982
 5-29-81
 SHEET 1 of 4

PARTS LIST

CONFIGURATION				PARTS LIST							ITEM NO.
QTY REQD	QTY REQD	QTY REQD	PART OR IDENTIFYING NO.	CODE IDENT	NOMENCLATURE OR DESCRIPTION	SPECIFICATION OR MANUFACTURER	CKT REF	REV.	REV.		
<1			CK06BX104K M39014/02-1270		CAPACITOR, .1 μ f/100V	MIL-C-39014	C102 C105		18		
<1			M39014/02-1246 CK05BX330K M39014/01-1330		CAPACITOR, 2200pf, 200V CAPACITOR, 33pf, 200V	MIL-C-39014 MIL-C-39014	C103 C104 C108		19 20		
<1			UY03471J		CAPACITOR, 470pf, +1%, 100V	1A015-284V-311	C107		21		
10			M39003/01-2764		33 μ fd/20V CAPACITOR	MIL-C-39003	C106		22		
									23		
									24		
									25		
28			RNC55H3012FR		30.1K, 1%, 125mW RESISTOR	MIL-R-55182	R101		26		
<1			RNC55H3012FR		30.1K, 1%, 125mW RESISTOR		R102		27		
5			RNC55H2050FR		20 Ω , 1%, 1/8W		R103		28		
<1			RNC55H1001FS		1K, 1%, 1/8W		R104		29		
<1			RNC55H492FR		49.9K, 1%, 1/8W		R105		30		
3			RNC55HXXXXFR		SIT, 1%, 1/8W	MIL-R-55182	R106		31		
5			RA20LAS82524		2.5K, Pot	MIL-R-19/2	R107		32		
3			RNC55H9531FR		9.53K, 1%, 1/8W	MIL-R-55182	R108		33		
<1			RNC55H2492FS		24.9K, 1%, 1/8W	MIL-R-55182	R109		34		

<p>TRW DEFENSE AND SPACE SYSTEMS GROUP CORP. SPACE PARK • REDONDO BEACH, CALIFORNIA</p>	SIZE	FSCM NO.	<p>INPUT/OUTPUT SENSE ELECTRONICS DC TO DC POWER PROCESSOR</p>
	A	11982	
		SHEET 2 of 4	

CONFIGURATION				PARTS LIST						
QTY REQD	QTY REQD	QTY REQD	PART OR IDENTIFYING NO.	CODE IDENT	NOMENCLATURE OR DESCRIPTION	SPECIFICATION OR MANUFACTURER	CKT REF	ITEM NO.		
3.5			RNC55H3481FR		3.48K, 1%, 1/8W RESISTOR		R110	35		
3			RNC55H3011FS		3.01K, 1%, 1/8W		R111	36		
<1			RNC55H2492FR		24.9K, 1%, 1/8W		R112	37		
40			RA20LASB252A		2.5K POT	MIL-R-19/2	R113	38		
4.3			RNC55HXXXFR		SIT, 1%, 1/8W		R114	39		
<1			RNC55H4421FS		4.47K, 1%, 1/8W		R115	40		
<1			RNC55H1002FS		10K, 1%, 1/8W		R116	41		
<1			RNC55H5622FS		56.2K, 1%, 1/8W		R117	42		
<1			RNC55H2942FS		29.4K, 1%, 1/8W		R118	43		
<1			RNC55H5111FR		5.11K, 1%, 1/8W		R119	44		
<1			RNC55H1002FS		10K, 1%, 1/8W		R120	45		
100			RWR80S1211FR RWR81S1211FR		1.21K, 1%, 1W		R121	46		
<1			RNC55H1002FS		10K, 1%, 1/8W		R122	47		
<1			RNC55H5122FR		51.1K, 1%, 1/8W		R123	48		
<1			RNC55H4022FR		40/2, 1%, 1/8W		R124	49		
2			RNC55H4021FR		4.02K, 1%, 1/8W		R125	50		
<1			RNC55H1001FR		.1K, 1%, 1/8W RESISTOR		R126	51		

TRW <small>DEFENSE AND SPACE SYSTEMS GROUP</small> <small>ONE SPACE PARK • REDONCO BEACH, CALIFORNIA</small>		SIZE A FSCM NO. 11982	REV. 3 INPUT/OUTPUT SENSE ELECTRONICS DC TO DC POWER PROCESSOR
		SHEET 3 of 4	

CONFIGURATION				PARTS LIST					ITEM NO.
QTY REQD	QTY REQD	QTY REQD	PART OR IDENTIFYING NO.	CODE IDENT	NOMENCLATURE OR DESCRIPTION	SPECIFICATION OR MANUFACTURER	CKT REF	ITEM NO.	
3.5			RNC55H3481FR		3.48K, 1%, 1/8W RESISTOR		R110	35	
3			RNC55H3011FS		3.01K, 1%, 1/8W		R111	36	
<1			RNC55H2492FR		24.9K, 1%, 1/8W		R112	37	
40			RA20LASB252A		2.5K POT	MIL-R-19/2	R113	38	
4.3			RNC55HXXXFR		SIT, 1%, 1/8W		R114	39	
<1			RNC55H4421FS		4.47K, 1%, 1/8W		R115	40	
<1			RNC55H1002FS		10K, 1%, 1/8W		R116	41	
<1			RNC55H5622FS		56.2K, 1%, 1/8W		R117	42	
<1			RNC55H2942FS		29.4K, 1%, 1/8W		R118	43	
<1			RNC55H5111FR		5.11K, 1%, 1/8W		R119	44	
<1			RNC55H1002FS		10K, 1%, 1/8W		R120	45	
100			RWR80S1211FR RWR81S1211FR		1.21K, 1%, 1W		R121	46	
<1			RNC55H1002FS		10K, 1%, 1/8W		R122	47	
<1			RNC55H5122FR		51.1K, 1%, 1/8W		R123	48	
<1			RNC55H4022FR		40/2, 1%, 1/8W		R124	49	
2			RNC55H4021FR		4.02K, 1%, 1/8W		R125	50	
<1			RNC55H1001FR		.1K, 1%, 1/8W RESISTOR		R126	51	

TRW <small>DEFENSE AND SPACE SYSTEMS GROUP</small>		SIZE A	FSCM NO. 11982	REV.
OFF: 1-PAGE PARK • REDONDO BEACH, CALIF. 90740		INPUT/OUTPUT SENSE ELECTRONICS DC TO DC POWER PROCESSOR		SHEET 3 of 4

CONFIGURATION				PARTS LIST						
QTY REQD	QTY REQD	QTY REQD	PART OR IDENTIFYING NO.	CODE IDENT	NOMENCLATURE OR DESCRIPTION	SPECIFICATION OR MANUFACTURER	CKT REF	ITEM NO.		
<1			RNC55H4022FS		40.2K, 1%, 1/8W RESISTOR	MIL-R-44182	R127	52		
37			RNC55H3402FR		34K, 1%, 1/8W		R128	53		
8			RNC55H6651FS		6.65K, 1%, 1/8W		R129	54		
<1			RNC55HXXXFR		SIT, 1%, 1/8W		R130	55		
<1			RNC55H4022FS		40.2K, 1%, 1/8W		R131	56		
<1			RNC55H4022FS		40.2K, 1%, 1/8W		R132	57		
160			PWR81SXXXFR		SIT, 1%, 1W	MIL-R-39007	R133	58		
								59		
								60		
								61		
10			T1745		PULSE TRANSFORMER		T101	62		
10			T1734		ASDTIC TRANSFORMER		T102	63		
								64		
								65		
								66		
								67		
								68		

TRW <small>DEFENSE AND SPACE SYSTEMS GROUP</small> ONE SPACE PARK • REDONDO BEACH, CALIFORNIA	SIZE A	FSCM NO. 11982	INPUT/OUTPUT SENSE ELECTRONICS DC TO DC POWER PROCESSOR	REV.
	SHEET 4 of 4			

CONFIGURATION				PARTS LIST							REV.
P diss	QTY REQD	QTY REQD	PART OR IDENTIFYING NO.	CODE IDENT	NOMENCLATURE OR DESCRIPTION	SPECIFICATION OR MANUFACTURER	CKT REF	ITEM NO.			
			2N5154		TRANSISTOR (NPN)		Q1	1			
90			2N5154		TRANSISTOR (NPN)		Q2	2			
13580			55EJ106		TRANSISTOR POWER	1P241-001	Q3	3			
13580			55EJ106		TRANSISTOR POWER	1P241-001	Q4	4			
<10			2N2907A		TRANSISTOR (PNP)		Q5	5			
								6			
								7			
								8			
24			1N5811	260	DIODE 6A, 150V		CR1	9			
24			1N5811	260	DIODE 6A, 150V		CR2	10			
3656			SCDA2F		DIODE 200V, 5A	SEMTECH	CR3	11			
4480			SCDA2F		DIODE 200V, 5A	SEMTECH	CR4	12			
50			1N5811	260	DIODE 6A, 150V		CR7	13			
50			1N5811	260	DIODE 6A, 150V		CR8	14			
18750					DIODE	SEMTECH	CR9, CR10 CR11	15			
100			1N5811	260	DIODE 6A, 150V		CR12	16			
								17			

TRW
DEFENSE AND SPACE SYSTEMS GROUP
 ONE SPACE CENTER • REDONDO BEACH, CALIFORNIA
 Σ P_{diss} = 81.13W
 SIZE **A** FSCM NO. **11982**
 4-6-79 SHEET 1 of 6

CONFIGURATION				PARTS LIST							REV.
P	QTY REQD	QTY REQD	QTY REQD	PART OR IDENTIFYING NO.	CODE IDENT	NOMENCLATURE OR DESCRIPTION	SPECIFICATION OR MANUFACTURER	CKT REF	ITEM NO.		
									18		
				SN54LS221J	274	IC (MULTIVIBRATOR)	1H592-001V	U1	19		
10				SN54LS001F	273	IC (4-INPUT NAND GATE) 2-Input Quad		U2	20		
10				LM139AD	273	IC (VOLTAGE COMPARATOR)		U3	21		
				LM140AK		IC (VOLTAGE REGULATOR)		U4	22		
10				SN54LS20J	273	IC (4-INPUT NAND GATE) 4-Input Dual		U5	23		
10				SN54LS00F	273	IC (4-INPUT NAND GATE) 2-Input Quad		U6	24		
25				SE555T	113	IC (TIMING CIRCUIT)		U7	25		
				55452B-JG		IC (TTL, DUAL NAND)		U8	26		
									27		
									28		
									29		
<1				M39014/02-1350	324	.1μfd/100V CAPACITOR		C1	30		
<1				UY SERIES		180pfd +2%, 100V CAPACITOR	1A015-245V-311	C2	31		
<1				UY SERIES		180pfd +2%, 100V CAPACITOR	1A015-245V-311	C3	32		
<1				M39003/01-2769	281	15μfd/20V CAPACITOR		C4	33		
<1				M39003/01-2769	281	15μfd/20V CAPACITOR		C5	34		
				SIZE		FSCM NO.					
				A		11982		1/2 POWER MODULE DC-DC POWER PROCESSOR			
				TRW		DEFENSE AND SPACE SYSTEMS GROUP		SHEET 2 of 6			
				ONE SPACE MARK - RED INK BEARING ALUMINA							

CONFIGURATION				PARTS LIST						
P	QTY REQD	QTY REQD	QTY REQD	PART OR IDENTIFYING NO.	CODE IDENT	NOMENCLATURE OR DESCRIPTION	SPECIFICATION OR MANUFACTURER	CKT REF	ITEM NO.	
<1				M39014/02-1350	324	.1µfd/100V CAPACITOR		C6	35	
<1				CYFR20512A		5100pfd +1%, 300V CAPACITOR	1A008-070V-314	C7	36	
<1				M39014/02-1350		.1µfd/100V CAPACITOR		C8	37	
<1								C9	38	
<1								C10	39	
<1				M39014-02-1350		.1µfd/100V		C11	40	
100				91F148BNA		2800µfd/55V		C12	41	
100								C13	42	
100								C14	43	
100						BRACKETS FOR 2800µfd.		C15	44	
100								C16	45	
100				91F148BNA		2800µfd/55V		C17	46	
								C18	47	
<1				M39014/02-1258		.01µfd/200V		C19	48	
<1				M39014/02-1258		.01µfd/200V		C20	49	
500				CB12D474KX7		.47/200 CAPACITOR		C21	50	
								C22	51	
				TRW <small>DEFENSE AND SPACE SYSTEMS GROUP</small> <small>ONE SPACE PARK • REDONDO BEACH, CALIFORNIA</small>		SIZE	FSCM NO.	REV.		
						A	11982	1/2 POWER MODULE DC-DC POWER PROCESSOR		
								SHEET 3 of 6		

CONFIGURATION				PARTS LIST						
Pd	QTY REQD	QTY REQD	QTY REQD	PART OR IDENTIFYING NO.	CODE IDENT	NOMENCLATURE OR DESCRIPTION	SPECIFICATION OR MANUFACTURER	CKT REF	ITEM NO.	
500						.5/200V	CAPACITOR	C23	52	
10				91F148BHA		2800µfd/55V	CAPACITOR	C24	53	
10				91F148BHA		2800µfd/44V	CAPACITOR	C25	54	
<1				39014/01-1259		100µfd/200V	CAPACITOR	C26	55	
									56	
									57	
6.5				RCR05G202JS		2K,5%, 1/8W	RESISTOR	R1	58	
6.5				RCR05G202JS		2K,5%, 1/8W	RESISTOR	R2	59	
<1				RCR05G103JS		10K,5%, 1/8W	RESISTOR	R3	60	
<1				RCR05G103JS		10K,5%, 1/8W	RESISTOR	R4	61	
<1				RNC55H1582FS		15.8K, 1%, 1/8 RESISTOR		R5	62	
<1				RNC55H1002FS		10K, 1%, 1/8 RESISTOR		R6	63	
<1				RNC55H3922FR		39.2K, 1%, 1/8 RESISTOR		R7	64	
<1				RNC55HXX1FR		SIT, 10%, 1/8 RESISTOR		R8	65	
<1				RBR56L48701BR		47.5K, 1/8W, 1% RESISTOR		R9	66	
<1				RCR56L47501BR				R10	67	
<1				RCR05G103JS		10K,5%, 1/8 RESISTOR		R11	68	
3				RNC55H2211FS		2.21K, 1%, 1/8 RESISTOR				

REV.	1/2 POWER MODULE DC-DC POWER PROCESSOR	SHEET 4 of 6
SIZE	FSCM NO.	
A	11982	
 <small>DEFENSE AND SPACE SYSTEMS GROUP</small> <small>ONE SPACE PARK • REDONDO BEACH, CALIFORNIA</small>		

CONFIGURATION				PARTS LIST						
Pdiss	QTY REQD	QTY REQD	PART OR IDENTIFYING NO.	CODE IDENT	NOMENCLATURE OR DESCRIPTION	SPECIFICATION OR MANUFACTURER	CKT REF	ITEM NO.		
<1			RNC55H4992FR		49.9K, 1%, 1/8W RESISTOR		R12	69		
3			RNC55H2211FS		2.21K, 1%, 1/8W RESISTOR		R13	70		
102			RWR81S1926FR		19.6Ω, 1%, 1W RESISTOR		R14	71		
			RCR20G201JS		200Ω, 5%, 1/2W RESISTOR		R15	72		
			RCR20G201JS		200Ω, 5%, 1/2W RESISTOR		R16	73		
			RCR20G201JS		200Ω, 5%, 1/2W RESISTOR		R17	74		
			RCR20G201JS		200Ω, 5%, 1/2W RESISTOR		R18	75		
			RWR80S10000FR		100Ω, 1%, 2W RESISTOR		R19	76		
			RWR80S10000FR		100Ω, 1%, 2W RESISTOR		R20	77		
20			RCR05G101JS		100Ω, 5%, 1/8W RESISTOR		R21	78		
20			RCR05G101JS		100Ω, 5%, 1/8W RESISTOR		R22	79		
<15			RCR20G103JS		10K, 5%, 1/2W RESISTOR		R23, R24 R27	80		
<1			RNC55H4991FR		4.99K, 1%, 1/8W RESISTOR		R25	81		
			RCR05G561JS		560Ω, 5%, 1/8W RESISTOR		R26	82		
199			L-1492		INDUCTOR, SPIKE SUPPRESSION		L1	83		
10000			L-1473D		INDUCTOR,		L3	85		

REV.	
SIZE	FSCM NO.
A	11982
1/2 POWER MODULE DC-DC POWER PROCESSOR	
SHEET	5 of 6

TRW
DEFENSE AND SPACE SYSTEMS GROUP
 ONE SPACE PLAZA • FORT BELVOIR BEACH, CA. 94964

CONFIGURATION				PARTS LIST						
P	QTY REQD	QTY REQD	QTY REQD	PART OR IDENTIFYING NO.	CODE IDENT	NOMENCLATURE OR DESCRIPTION	SPECIFICATION OR MANUFACTURER	CKT REF	ITEM NO.	
								T1	86	
105				T-1738-A		TRANSFORMER-CURRENT DRIVE		T2	87	
105				T-1738-A		TRANSFORMER-CURRENT DRIVE		T3	88	
<10				T-1733-A		TRANSFORMER-PEAK CURRENT SENSE		T4	89	
<10				T-1733-A		TRANSFORMER-PEAK CURRENT SENSE		T5	90	
12127				T-1739-A		TRANSFORMER POWER		T6	91	
<10				T-1788		TRANSFORMER-PEAK CURRENT SENSE		T7	92	
									93	
									94	
									95	
									96	
									97	
									98	
									99	
									100	
									101	
									102	

TRW <small>DEFENSE AND SPACE SYSTEMS GROUP</small> <small>ONE SPACE PARK • REDONDO BEACH • CALIFORNIA</small>	SIZE A	FSCM NO. 11982	1/2 POWER MODULE DC-DC POWER PROCESSOR	REV.
	SHEET 6 of 6			

CONFIGURATION				PARTS LIST						
P _d ISS	QTY REQD	QTY REQD	QTY REQD	PART OR IDENTIFYING NO.	CODE IDENT	NOMENCLATURE OR DESCRIPTION	SPECIFICATION OR MANUFACTURER	CKT REF	ITEM NO.	
<1				2N3700		TRANSISTOR, 1A/80V (NPN)			1	
				2N5005		TRANSISTOR, 5A/80V (PNP)			2	
				2N3637		TRANSISTOR (NPN)			3	
10				2N3700		TRANSISTOR, 1A/80V (NPN)			4	
				2N5154		TRANSISTOR (NPN)			5	
34				2N5154		TRANSISTOR (NPN)			6	
									7	
									8	
									9	
				1N756A		DIODE, ZENER			10	
				1N4573A		DIODE, ZENER			11	
									12	
									13	
									14	
17				1N5290A		DIODE, CONSTANT CURRENT (.47mA)			15	
5.6				1N5806		DIODE, 3A/150V			16	
				1N5816		DIODE, 15A/150V			17	

TRW
DEFENSE AND SPACE SYSTEMS GROUP

$\Sigma P_{diss} = 3341mW$

ONE SPACE PARK • REDONDO BEACH, CALIFORNIA

SIZE FSCM NO.

A 11982

INTERNAL POWER SUPPLY
 DC TO DC POWER PROCESSOR

REV.

4-6-79

SHEET 1 of 4

CONFIGURATION				PARTS LIST							REV.
QTY REQD	QTY REQD	QTY REQD	PART OR IDENTIFYING NO.	CODE IDENT	NOMENCLATURE OR DESCRIPTION	SPECIFICATION OR MANUFACTURER	CKT REF	ITEM NO.			
4			1N5806		DIODE 3A/150V			18			
7			1N5806		DIODE 3A/150V			19			
4			1N5811		DIODE 6A/160V			20			
7			1N5811		DIODE 6A/150V			21			
7			1N5811		DIODE 6A/150V			22			
4			1N5811		DIODE 6A/150V			23			
								24			
								25			
								26			
30			LM111H		IC, COMPARATOR			27			
								28			
								29			
								30			
47			M39003/01-2661		15 μ fd/75V CAPACITOR			31			
< 1			M39003/01-2532		33 μ fd/20V CAPACITOR			32			
< 1			M39003/01-2596		1 μ fd/50V CAPACITOR			33			
14			M39003/01-2781		100 μ fd/20V CAPACITOR			34			
				SIZE	FSCM NO.	INTERNAL POWER SUPPLY DC TO DC POWER PROCESSOR		REV.			
				A	11982						
				4-6-79				SHEET 2 of 4			

TRW

DEFENSE AND SPACE SYSTEMS GROUP

ORIGINATOR: TRW • REFERENCE: BEA 014, CALIFORNIA

CONFIGURATION				PARTS LIST					REV.
QTY REQD	QTY REQD	PART OR IDENTIFYING NO.	CODE IDENT	NOMENCLATURE OR DESCRIPTION	SPECIFICATION OR MANUFACTURER	CKT REF	ITEM NO.		
<1		M39003/01-1332		4700 μ fd/200V CAPACITOR			35		
<1		M39003/01-2532		33 μ fd/20 CAPACITOR			36		
<1		M39003/01-2620		22 μ fd/50V			37		
							38		
							39		
							40		
10		RNC55H1000FS		100 Ω , 1%, 1/8W RESISTOR			41		
4		RNC55H1001FS		1K, 1%, 1/8W RESISTOR			42		
		RNR80S1001FS		1K, 1%, 2W RESISTOR			43		
9		RNC55H1002FR		10K, 1% RESISTOR			44		
1		RNC55H4122FS		41.2K, 1%, 1/2W RESISTOR			45		
<1		RNC55H5111FR		5.11K, 1%, 1/2W RESISTOR			46		
6		RNC55H3741FS		3.74K, 1%, 1/2W RESISTOR			47		
7		RNC55H4751FS		4.75K, 1%, RESISTOR			48		
2.3		RNC55HXXXXFR		SIT, 1% RESISTOR			49		
4.5		RNC55H3011FR		3.01K, 1%, RESISTOR			50		
5		RNC55H2871FR		2.87K, 1%, RESISTOR			51		
TRW <small>DEFENSE AND SPACE SYSTEMS GROUP</small> <small>ONE SPACE CASE • METHODIC BEACH • CALIFORNIA</small>				SIZE	FSCM NO.	INTERNAL POWER SUPPLY DC TO DC POWER PROCESSOR		REV.	
				A	11982				
				4-6-79	SHEET 3 of 4				

CONFIGURATION				PARTS LIST						
QTY REQD	QTY REQD	QTY REQD	PART OR IDENTIFYING NO.	CODE IDENT	NOMENCLATURE OR DESCRIPTION	SPECIFICATION OR MANUFACTURER	CKT REF	ITEM NO.		
<1			RNC55H1001FS		1K, 1/8W, 1% RESISTOR			52		
37			RNC8052R00FR		2Ω, 1W, 1% RESISTOR			53		
13			RNC55H1002FS		10K, 1/8W, 1% RESISTOR			54		
6			RCR076200JS		20Ω 1/8W, 5% RESISTOR			55		
13			RNC55H1002FR		10K, 1/8W, 1% RESISTOR			56		
11			RWR81S3010FR		301Ω, 1W, 1% RESISTOR			57		
11			RWR81S3010FR		301Ω, 1W, 1% RESISTOR			58		
127			RWR81S1001FR		1K, 1W, 1W, 1% RESISTOR			59		
								60		
								61		
								62		
			<-1519A		INDUCTOR, AVERAGING CHOKE			63		
								64		
								65		
								66		
			T-1735E		TRANSFORMER, POWER			67		
								68		

REV.	INTERNAL POWER SUPPLY	SHEET 4 of 4
	DC TO DC POWER PROCESSOR	
SIZE	FSCM NO.	
A	11982	

TRW

DEFENSE AND SPACE SYSTEMS GROUP

10000 WILSON BLVD, REDDING, CA 96001

AD-A107 676 TRW DEFENSE AND SPACE SYSTEMS GROUP REDONDO BEACH CA --ETC F/6 10/2
TWO POINT FOUR KW DC/DC CONVERTER REGULATOR.(U)
OCT 81 R E EGGERT

DAAB07-78-C-2988

DELET-TR-78-2988-F

NL

UNCLASSIFIED

2 OF 2

ADA
10/6/80



END

DATE

FILED

1 82

DTIC

CONFIGURATION				PARTS LIST							REV.
QTY REQD	QTY REQD	QTY REQD	PART OR IDENTIFYING NO.	CODE IDENT	NOMENCLATURE OR DESCRIPTION	SPECIFICATION OR MANUFACTURER	CKT REF	ITEM NO.			
			AM1516-130-50DC-1		150A SINGLE POLE BREAKER	HEINMANN		1			
			2XAM1516-100		100A Z POLE BREAKER	HEINMANN		2			
								3			
								4			
			5226-8941		100MV FULL SCALE	WESTON MODEL		5			
								6			
								7			
								8			
			101-5030-971		LIGHT INDICATOR -RED	DIALITE		9			
			CM3150 CM330		LAMP, INCANDESCENT 14V			10			
								11			
			FHL1862-2		FUSE HOLDER			12			
			FHL1862-3		FUSE HOLDER INDICATOR			13			
			313.250		3AG FUSE, AMP 2	LITTLE FUSE		14			
								15			
			MS24524-26		ON-NONE-MOMENTARY ON	111L-C-39500C		16			
								17			
TRW <small>DEFENSE AND SPACE SYSTEMS GROUP</small> ONE SPACE PARK • REDONDO BEACH, CALIFORNIA				SIZE	FSCM NO.	DC TO DC POWER PROCESSOR CHASSIS ASSY		SHEET 1 of 3			
				A	11982						

CONFIGURATION				PARTS LIST					
QTY REQD	QTY REQD	QTY REQD	QTY REQD	PART OR IDENTIFYING NO.	CODE IDENT	NOMENCLATURE OR DESCRIPTION	SPECIFICATION OR MANUFACTURER	CKT REF	ITEM NO.
1				91, F 148BJA		2800 μ f / 55VDC			18
				91, F 148BJA		LOCATED IN POWER MODULE			19
				91, F 148BJA		LOCATED IN POWER MODULE			20
1				LP8A1L106K		10/75 CAPACITOR			21
1				LP8A		10/75 CAPACITOR			22
1				LP8A		10/75 CAPACITOR			23
1				LP8A		10/75 CAPACITOR			24
1				650B1C474J		.47 μ f 200V POLY CAP			25
									26
									27
3000						INPUT FILTER INDUCTOR			28
5000						INPUT FILTER INDUCTOR			29
						INPUT FILTER INDUCTOR			30
1				L-1497		SHORTING INDUCTOR			31
1				L-1497		SHORTING INDUCTOR			32
1				L-1505		SATURABLE REACTOR			33
1				L-1505		SATURABLE REACTOR			34

TRW <small>DEFENSE AND SPACE SYSTEMS GROUP</small> ONE SPACE PARK • REDONDO BEACH, CALIFORNIA		SIZE	FSCM NO.	REV
		A	11982	
		DC TO DC POWER PROCESSOR CHASSIS ASSY		
				SHEET 2 of 3

CONFIGURATION				PARTS LIST							REV
QTY REQD	QTY REQD	QTY REQD	QTY REQD	PART OR IDENTIFYING NO.	CODE IDENT	NOMENCLATURE OR DESCRIPTION	SPECIFICATION OR MANUFACTURER	CKT REF	ITEM NO.		
1				-1505		SATURABLE REACTOR		SR303	35		
1				MA141D		MAGNETIC AMPLIFIER		MA301	36		
									37		
									38		
									39		
									40		
1				NH-50-25Ω		25Ω 50W NON-IND RES	DALE	R301 R302	41		
1				9992-0041239		SHUNT	WESTON	R303	42		
				RNC55H492FR		49.9K, 1% 1/8W	MIL-R-55182	R304	43		
									44		
				STFF15DL		20A, 150V DIODE	SEMTECH	CR1	45		
									46		
2				M24308/1-1		9-SOCKET, SUB-MIN TYPE D CONV			47		
2				M24308/3-1		9-PIN			48		
5				M24308/1-3		25 - SOCKET			49		
5				M24308/3-3		25 - PIN			50		
									51		
				TRW <small>DEFENSE AND SPACE SYSTEMS GROUP</small> ONE SPACE PARK • REDONDO BEACH, CALIFORNIA			SIZE A FSCM NO. 11982	DC TO DC POWER PROCESSOR CHASSIS ASSY		REV	
							SHEET 3 of 3				

DATE
ILMEI