

2

LEVEL II

12

AD A107810

DNA 5723T

A STEPPED-FREQUENCY HF RADAR FOR IONOSPHERIC DIAGNOSTICS

Juris Petriceks
Charles L. Rino
Walter G. Chesnut
SRI International
333 Ravenswood Avenue
Menlo Park, California 94025

DTIC
NOV 27 1981

E

20 March 1981

Topical Report for Period 16 June 1980—16 January 1981

CONTRACT No. DNA 001-80-C-0255

APPROVED FOR PUBLIC RELEASE;
DISTRIBUTION UNLIMITED.

THIS WORK SPONSORED BY THE DEFENSE NUCLEAR AGENCY
UNDER RDT&E RMSS CODE B322080462 I25AAXHX64216 H2590D.

Prepared for
Director
DEFENSE NUCLEAR AGENCY
Washington, D. C. 20305

DTIC FILE COPY

81 11 26 020

Destroy this report when it is no longer needed. Do not return to sender.

PLEASE NOTIFY THE DEFENSE NUCLEAR AGENCY,
ATTN: STTI, WASHINGTON, D.C. 20305, IF
YOUR ADDRESS IS INCORRECT, IF YOU WISH TO
BE DELETED FROM THE DISTRIBUTION LIST, OR
IF THE ADDRESSEE IS NO LONGER EMPLOYED BY
YOUR ORGANIZATION.



UNCLASSIFIED

SECURITY CLASSIFICATION OF THIS PAGE (When Data Entered)

REPORT DOCUMENTATION PAGE		READ INSTRUCTIONS BEFORE COMPLETING FORM
1 REPORT NUMBER DNA 5723T	2. GOVT ACCESSION NO. AD-A127 810	3 RECIPIENT'S CATALOG NUMBER
4. TITLE (and Subtitle) A STEPPED-FREQUENCY HF RADAR FOR IONOSPHERIC DIAGNOSTICS		5. TYPE OF REPORT & PERIOD COVERED Topical Report for Period 16 Jun 80—16 Jan 81
		6. PERFORMING ORG. REPORT NUMBER SRI Project 1827
7 AUTHOR(s) Juris Petriceks Charles L. Rino Walter G. Chesnut		8 CONTRACT OR GRANT NUMBER(s) DNA 001-80-C-0255
9 PERFORMING ORGANIZATION NAME AND ADDRESS SRI International 333 Ravenswood Avenue Menlo Park, California 94025		10 PROGRAM ELEMENT PROJECT, TASK AREA & WORK UNIT NUMBERS Subtask I25AAXHX642-16
11 CONTROLLING OFFICE NAME AND ADDRESS Director Defense Nuclear Agency Washington, D.C. 20305		12 REPORT DATE 20 March 1981
		13. NUMBER OF PAGES 32
14 MONITORING AGENCY NAME & ADDRESS (if different from Controlling Office)		15 SECURITY CLASS (of this report) UNCLASSIFIED
		15a. DECLASSIFICATION DOWNGRADING SCHEDULE N/A
16 DISTRIBUTION STATEMENT (of this Report) Approved for public release; distribution unlimited.		
17 DISTRIBUTION STATEMENT (of the abstract entered in Block 20, if different from Report)		
18 SUPPLEMENTARY NOTES This work sponsored by the Defense Nuclear Agency under RDT&E RMSS Code B322080462 I25AAXHX64216 H2590D.		
19 KEY WORDS (Continue on reverse side if necessary and identify by block number) Ionospheric irregularities Irregularity structure Field-aligned backscatter HF radar Spread F		
20 ABSTRACT (Continue on reverse side if necessary and identify by block number) Naturally occurring ionospheric disturbances generate structure over an extremely large range of scale sizes and intensities. To diagnose the interacting plasma processes that cause this structure continuum requires a variety of complex instruments. This report describes a multiple-frequency HF backscatter radar that can measure the Doppler spectrum of structure in the scale-size region from tens of meters to meters. This structure regime is important in its own right and acts as tracer for macroscale parameters such as plasma depletions, currents, and electric fields.		

DD FORM 1 JAN 73 1473

EDITION OF 1 NOV 65 IS OBSOLETE

UNCLASSIFIED

SECURITY CLASSIFICATION OF THIS PAGE (When Data Entered)

UNCLASSIFIED

SECURITY CLASSIFICATION OF THIS PAGE (When Data Entered)

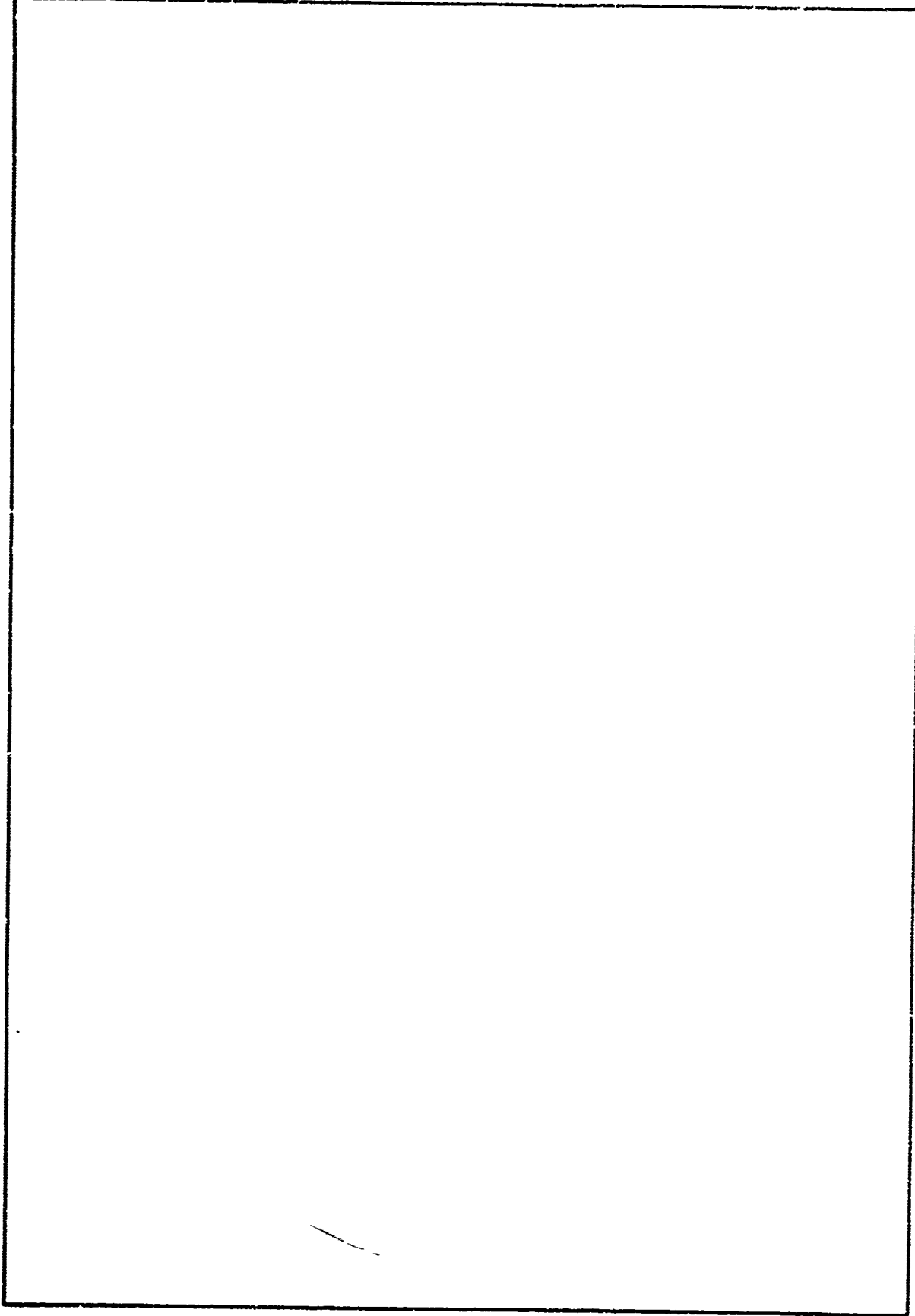

UNCLASSIFIED

SECURITY CLASSIFICATION OF THIS PAGE (When Data Entered)

Accession For	
NTIS G. & I	<input checked="" type="checkbox"/>
DTIC TAB	<input type="checkbox"/>
Unannounced	<input type="checkbox"/>
Justification	
R-	
Distribution/	
Availability Codes	
Avail and/or	
Dist	Special
A	

TABLE OF CONTENTS

<u>Section</u>	<u>Page</u>
LIST OF ILLUSTRATIONS	2
LIST OF TABLES	2
I INTRODUCTION	3
II HF DIAGNOSTIC RADAR	5
A. General Considerations	5
B. Sensitivity	6
C. Operational Parameters	7
D. Antenna	9
1. Overall Requirements	9
2. Design Choices	10
3. Scanning Option	12
E. Transmitter and Receiver	13
1. Overall Requirements	13
2. Design and Suppliers	14
F. Control and Data Acquisition	14
1. Overall Requirements	14
2. Design	17
III SYSTEM COSTS AND RECOMMENDATIONS	19
REFERENCES	24

LIST OF ILLUSTRATIONS

<u>Figure</u>		<u>Page</u>
1	Pattern of an Inverted Log-Periodic Antenna	11
2	Array Directivity versus Element Spacing	12
3	Transmit Section Block Diagram	15
4	Receive Section Block Diagram	16
5	System Control and Data Processing Block Diagram	18

LIST OF TABLES

<u>Table</u>		<u>Page</u>
1	Hardware Costs	20
2	Labor Costs	20
3	Installation and Operation Costs	22
4	Cost Summary	23

I INTRODUCTION

Naturally occurring ionospheric disturbances generate irregularities over extremely large ranges of scale sizes and intensities. Understanding the interrelated physical processes that sustain these structures is important for modeling naturally occurring processes and similar processes that may occur in a disturbed nuclear environment. A variety of instrumentation is required to diagnose these processes fully.

The Wideband Satellite [Rino et al., 1980], for example, has made extensive equatorial and auroral-zone scintillation measurements from which irregularity structures down to a few hundred meters can be inferred. Rocket probes have recently made measurements down to one-meter scale sizes. Evidence of significant structures at smaller scale sizes has come exclusively from measurements made by backscatter radars, which are sensitive to structures characterized by the spatial wave number, k , that is twice the spatial wave number of the radar frequency ($k = 2k_R = 4\pi/\lambda_R = 4\pi f_R/c$).

The enhanced backscatter occurs when plasma waves are excited by a variety of instability mechanisms. Depending on the instability "driver," the backscatter strength and Doppler shift can be used to measure background ionospheric parameters. The Homer [Tsunoda and Presnell, 1976] and STARE [Greenwald et al., 1978] radars have been used to map auroral-zone electric fields spatially. Backscatter at 50 MHz from the equatorial electrojet and the auroral electrojet has been shown, experimentally [Farley, 1970; Greenwald et al., 1973] and theoretically [Sudan and Keskinen, 1979] to be proportional to the strength of the electrojet current. Moreover, the Doppler structure of the backscatter echo is related to the plasma dispersion relation of the instability.

Most of the scientific applications of radar backscatter have been pursued at VHF where refractive bending of the radar ray is negligible. It is recognized, however, that operation at lower HF frequencies can potentially explore larger irregularity structures. Such operation,

however, must accommodate all the complexities introduced by refractive ray bending. Nonetheless, refractive bending can be used advantageously to achieve the necessary perpendicularity condition in regions that would otherwise be inaccessible for radar backscatter measurements.

In this report, therefore, we have emphasized a system that can accommodate essentially the entire HF range. In such a system the highest pulse repetition rate can only be achieved at the higher frequencies where ground clutter is minimized. Operational agility, i.e., a well-designed control system, is the key to the successful operation of such a radar.

A major concern in the design of such a radar is the size and cost of an antenna system that can probe the longest wavelengths of interest. The proposed antenna system consists of two log-periodic antenna arrays to cover the 8- to 64-MHz frequency range. The savings are substantial, however, if the lowest frequencies are eliminated.

Both the transmitter and receiver use conventional hardware available from electronic component manufacturers. The radar-control system employs a programmed microprocessor to set the frequency hopping and transmitter dwell times. The data-acquisition system uses a minicomputer in association with a correlator or array processor to integrate and analyze spectrally the digitally recorded data.

Section II of this report first describes in detail the constraints that dictate the performance requirements for the major system elements. Section II then describes in detail an antenna system, a transmitter, a receiver, and a control and data acquisition system that meet the design criteria. Section III describes the estimated costs of building the radar system and our recommendations for its implementation.

II HF DIAGNOSTIC RADAR

A. General Considerations

Considerable experience has been gained over the last decade in using HF backscatter radars to measure quantitatively the backscatter from highly field-aligned irregularities known to be associated with auroral and equatorial spread F. We describe the design of an HF radar system that fully exploits this technology for monitoring and diagnosing spread F.

The functional elements of the radar include (1) the antenna system, (2) the transmitter, (3) the receiver, and (4) the control and data acquisition system. The transmitter and receiver are comparatively straightforward. We propose a coherent pulsed system that can be stepped in frequency from 8 MHz to 64 MHz with at least 20-kW peak power.

The lowest usable frequency is dictated by the ionospheric critical frequency and the severity of refractive effects as well as the size and complexity of the antenna system. The highest frequency is dictated by the achievable sensitivity, because the echo strength falls off very rapidly with increasing frequency. The system can, of course, be also used for HF propagation experiments in their own right.

The control and data acquisition system must control the frequency hopping and transmitter dwell and preprocess and digitally record the data as well as provide real-time displays. Determination of the echo Doppler structure and near Doppler shift is essential to identify the physical processes associated with the enhanced plasma waves and, at the lowest frequencies, for identifying refractive effects. Thus, the data acquisition system must include a correlator or fast Fourier transform (FFT) processing capability.

B. Sensitivity

As outlined previously, stepped-frequency HF backscatter radar can directly detect field-aligned backscatter. With sufficient sensitivity and appropriately designed antennas, the radar can quantitatively measure the striation spectral-density function in the small-scale (diffusion) regime and the Doppler spectrum.

As noted above, the critical frequency and refractive effects govern the lowest usable frequency for the backscatter measurements. Sensitivity dictates the highest frequency, because the echo strength falls off very rapidly with increasing frequency. Chesnut [1980] and Woodman and Basu [1978] have postulated that a significant change in the spectral-density function can be expected at $f \approx 30$ MHz; therefore, the radar frequency band should include this frequency range.

Extensive measurements of field-aligned backscatter associated with equatorial spread F have been performed by Balslev et al., [1972] at 55 MHz. We have, therefore, chosen as a baseline the capabilities of the 55-MHz radar system described by Balslev et al. [1972]. If we achieve the necessary sensitivity to detect field-aligned backscatter at 50 MHz, we expect to be able to characterize the striation spectral density in the small-scale regime.

Using a point-target figure of merit defined as

$$F.M. = P_T G^2 \lambda \tau \quad (1)$$

where P_T is the peak power, G is the antenna gain, λ is the wavelength, and τ is the pulse width, the system used by Balslev et al., [1972], had an $F.M. = 1.2 \times 10^6$ Ws for a pulse length of 100 μ s. For a beam filling target, the figure of merit is τ^2 dependent. In addition, the radar sensitivity is affected by duty cycle and dwell time. These quantities are in turn determined by the desired range resolution, expected return-signal Doppler shift, and allowable range ambiguity. The specific constraints are described below.

C. Operational Parameters

To derive the radar operational parameters such as pulse length, pulse repetition frequency, and dwell time at each frequency, we have to examine their interrelationships. For a pulse of duration, τ , the range resolution is given by the formula

$$\Delta R = \frac{c\tau}{2} \quad (2)$$

Thus, τ is determined by range resolution requirements or, conversely, the achievable range resolution is determined by τ as dictated by sensitivity requirements.

For a pulse-repetition rate of f_r Hz, echoes from beyond

$$R_a = \frac{c}{2f_r} \quad (3)$$

are superimposed on echoes from the primary ranges of interest and are, therefore, ambiguous. The maximum expected echo range, therefore, sets an upper bound on f_r . The quantity, f_r , also determines the Nyquist frequency, or the maximum unambiguously measurable velocity, because Doppler shifts beyond

$$V_a = \frac{\lambda f_r}{2} \quad (4)$$

fall within the primary Doppler interval.

To place some limits on the radar operational parameters we need to look at the characteristics of the medium to be measured. The spectral measurements of equatorial spread-F backscatter by Bisley et al. [1972], and Woodman and La Hoz [1976] show that at 50-MHz spectral widths as broad as 100 Hz can be expected. In addition, the return signals can have a Doppler shift of as much as 100 Hz. Backscatter measurements at 150 MHz by Tsunoda [1980] show that return strength falls off rapidly for ranges in excess of ~ 750 km.

The above measurements dictate a maximum usable $f_r = 200$ Hz, corresponding to $R_a = 750$ km, and a minimum usable $f_r = 100$ Hz, corresponding

to a Doppler shift (or spectral width) of 100 Hz. Since available broadband HF transmitters operate with duty cycles of $\sim 2\%$, the pulse repetition rate of 200 to 100 Hz sets the maximum pulse length at 100 to 200 μ s. The resulting range resolution is from 15 to 30 m, or better if shorter pulses or compressed pulses are used.

Additional limitations are placed on the radar operational parameters by the presence of single hop ground reflection returns. These clutter returns are both time and frequency dependent. In order to accommodate the clutter returns, the control and data acquisition system will need to be able to adjust the radar operational parameters in real time. The immediate effect of the ground reflection returns is the need to reduce f_r in order to accept a larger R_2 . Dwell time will need to be increased to maintain spectral measurement error bars at an acceptable level. It is clear that the requirement to reduce f_r will severely limit the spectral measurement capability of the radar.

Dwell time, $t_0 = n/f_r$, where n is the number of pulses, sets velocity resolution by the formula

$$\Delta V = \frac{\lambda}{2t_0} \quad (5)$$

To obtain a velocity resolution of 3 m/s at 50 MHz (corresponding to a one-Hz Doppler resolution) requires a coherent processing time of one second. However, to obtain spectral measurement error bars of less than two percent using the previously determined pulse repetition rates of 100 to 200 Hz, the dwell time would have to be increased to 15 s to allow averaging of the measured spectra.

The maximum observation time is set by the ionospheric motion and the antenna beamwidth transverse to the ionospheric motion. Using 300 m/s as the maximum ionospheric motion velocity and assuming a 5° antenna beamwidth, gives 100 s as the time required for a backscatter feature at an altitude of 300 to 400 km to move through the antenna beam. This limitation will allow seven transmitted frequencies to be used with a dwell time of 15 s at each frequency. The frequency range from 4- to 64-MHz can be adequately covered by seven frequency settings at 8, 12,

16,24,32,48, and 64 MHz. If a narrower beamwidth antenna is used either the dwell time or frequency coverage will have to be reduced.

The proposed stepped-frequency HF radar should have the following performance:

- Pulse repetition frequency, $f_r \leq 200$ Hz
- Pulse length, $\Delta t_p \geq 100$ μ s
- Dwell time, $t_o \leq 15$ s
- Operating frequencies, $f \approx 8, 12, 16, 24, 32, 48, \text{ and } 64$ MHz

These parameters are consistent with available two percent duty cycle transmitters and will accommodate ionospheric velocities of up to 300 m/s.

D. Antenna

1. Overall Requirements

The proposed stepped-frequency HF radar frequency range extends from 8 to 64 MHz. To measure the characteristics of the striation spectral-density function in the small-scale regime as a function of wavelength, the radar has to operate at several frequencies, and the change from one operational frequency to another has to be rapid, i.e., it has to occur well within one interpulse period. Thus the antenna must be broadband or we need several antennas (one for each frequency used) with a rapid-switching capability from one to another.

To achieve adequate sensitivity for the proposed measurements the antenna gain at 50 MHz (our baseline point) needs to be ≥ 20 dB. At lower frequencies the gain can be lower and at higher frequencies it will need to be higher. Moreover, to limit the extent of the ionosphere from which the backscatter is measured, the antenna beamwidth has to be narrow in the east-west direction (the north-south direction is automatically limited by the aspect sensitivity imposed by the highly field-aligned irregularities).

To map the backscatter strength spatially, the antenna would scan in the east-west direction. This, however, would only be done at a single frequency; one high enough that the antenna size will permit economical physical movement.

Some physical requirements arise from the required antenna electrical properties. Because this HF radar system is not likely to be a permanent installation, it should be transportable. It should also be compact enough to be used where only very limited land is available, e.g., Roi Namur Island.

2. Design Choices

The most common antenna type for HF radars is an array of dipoles. To achieve the necessary gain approximately 100 elements will have to be installed at each frequency used. If the arrays were square (i.e., 10 x 10) or rectangular (i.e., 4 x 25) with 0.5- λ element spacing the area required for the highest frequency (64 MHz) would be $\approx 550 \text{ m}^2$ (≈ 0.14 acre) and for the lowest frequency (8 MHz) $\approx 35,000 \text{ m}^2$ (≈ 8.5 acres). The limited land available for most temporary operations generally precludes the possibility of constructing large multiple arrays. Placing the arrays over water, such as on the lagoon side of Roi Namur Island is complicated not only by construction and maintenance problems but also by the varying height of the ground plane as the ocean surface changes.

Broadband antennas, therefore, are the most attractive solution for a viable antenna design. A common broadband antenna type is the log-periodic. HF communication systems have routinely used this kind of antenna. Single, commercially available, log-periodic antennas can provide 7- to 16-dBi gain with 40° to 60° beamwidths. Figure 1 shows an example of an antenna pattern of an inverted log-periodic mounted between two support towers. The sample pattern shown is for the lowest frequency of a horizontally polarized inverted log-periodic antenna. As frequency increases the H-plane pattern broadens and develops two lobes. This effect, however, is not prevalent until the frequency is tripled.

Using the log-periodic antenna as an element in a linear array can give the desired gain of ≥ 20 dB as well as provide a vertical fan-shaped beam. The half-power beamwidth (in degrees) is given by

$$\theta \approx \frac{50\lambda}{L} \quad (6)$$

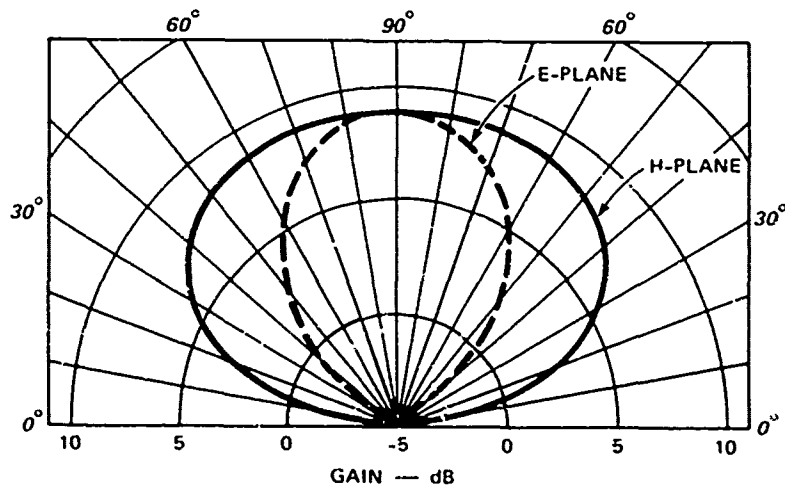

FIGURE 1 PATTERN OF AN INVERTED LOG-PERIODIC ANTENNA

where l is the length of the linear array. The effect of element spacing on array gain is shown in Figure 2. Thus, if the HF radar frequency coverage is broken into the 64- to 24-MHz band and 24- to 8-MHz band, the element spacing can be made 0.9λ at the top of the band (if 8 or more elements were used) and 0.36λ at the bottom of the band. The approximate 3.5-dB difference in array gain across the band will easily be made up by the increasing echo strength with decreasing frequency.

Splitting the HF radar frequency coverage into two bands offers another advantage. Namely, construction can be done in stages. If the higher-frequency band, which requires the least amount of land, provides sufficient data to characterize the striation spectral-density function in the small-scale regime, then the lower-frequency band may be eliminated. The required gain of ≥ 20 dB can be attained with 12 elements in a linear array. If the lower frequency band needed to be built, eight elements would suffice. The resulting beam will be fan shaped with a 5° by 40 to 60° beamwidth.

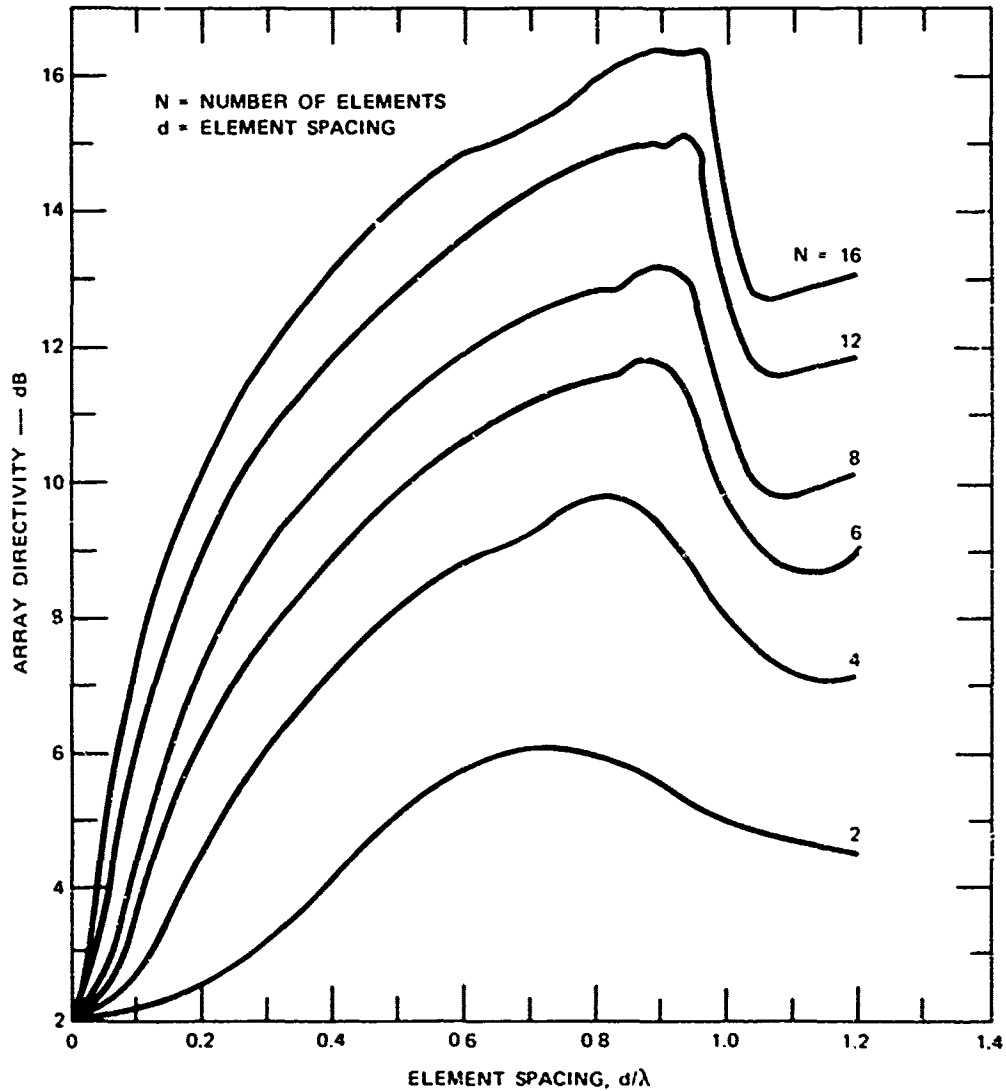

FIGURE 2 ARRAY DIRECTIVITY VERSUS ELEMENT SPACING

3. Scanning Option

An electronic scanning capability for the IIF radar can be used to map the field-aligned backscatter strength spatially. Such mapping has been previously done by using the mechanically steerable ALTAIR radar on Roi Namur Island [Tsunoda et al., 1979].

Although we have not costed the scanning option, the possibility of scanning at one frequency is considered in the following discussion. For the simple case of an equally spaced linear array, a main beam that is θ° off the array normal is formed by successively applying a phase difference of $\Delta\phi$ rad to each of the array elements:

$$\Delta\phi = \frac{2\pi}{\lambda} d \sin \theta \quad (7)$$

where d is the spacing between elements. Thus, the actual phase shift, ϕ_m , applied to the m^{th} element in a row of m equally spaced elements is:

$$\phi_m = (m - 1) \Delta\phi - \xi_m \quad (8)$$

where ξ_m is the phase-shift correction resulting from the transmission path to the m^{th} element.

Because the proposed array elements are log-periodic antennas with 40° to 60° beamwidth, the scan capability will be limited from $\pm 20^\circ$ to $\pm 30^\circ$ off the array normal. Furthermore, with an array beamwidth of $\sim 5^\circ$ eight to twelve independent positions can be realized. The complexity of maintaining the appropriate phase relationships is, however, a severe constraint.

E. Transmitter and Receiver

1. Overall Requirements

The broadband characteristics of the proposed radar are the controlling requirements of both the transmitter and receiver. The system sensitivity needs place minimum peak power requirements on the transmitter. Moreover, to switch from one operating frequency to another rapidly, the transmitter needs to be driven by an agile frequency source.

The measured quantities will deal with both the returned signal strength and spectral characteristics. Because the returned signal strength is expected to vary significantly across the proposed radar frequency band, the receiver needs to have a high dynamic range. To make the spectral measurements, the transmitter/receiver must also maintain frequency coherence. These requirements are readily achieved in commercially available equipment.

2. Design and Suppliers

To satisfy both the transmitter frequency agility and system coherence requirements, a central element in the design is the frequency synthesizer. The desired peak power of ≥ 20 kW at a two-percent duty cycle over the desired frequency range can be attained with hardware supplied by commercial contractors. Transmitter designs that cover the 8- to 64-MHz band have been previously used by Granger Associates in HF sounders and by Applied Research Corporation in over-the-horizon (OTH) systems.

A block diagram of the proposed HF radar transmit section is shown in Figure 3. Agility in transmitting frequency is provided by a frequency synthesizer that drives the high-power transmitter. The basic block diagram of a suitable receiver section is shown in Figure 4. The receiver consists of commercially available preamplifiers, filters, mixers, attenuators, power splitters, and miscellaneous other parts. To maintain frequency coherence, the same common local oscillator is used both in the transmit and receive sections of the radar.

The actual implementation of the low-power level part of the transmitter and the whole receiver can be accomplished by using a commercially available receiver such as the RACAL RA 6790. The addition of mixer, amplifier, and filter components gives the receiver a frequency generating capability; thus, it can also be used to drive the transmitter. The RA 6790 covers the frequency range from 0.5 to 30 MHz, therefore, a conversion stage will be added to extend its capabilities to 60 MHz.

F. Control and Data Acquisition

1. Overall Requirements

The three principal parts of system control and data processing are the control of operating parameters of the radar; acquisition, pre-processing, and recording of the radar data; and display in real-time of the experiment status.

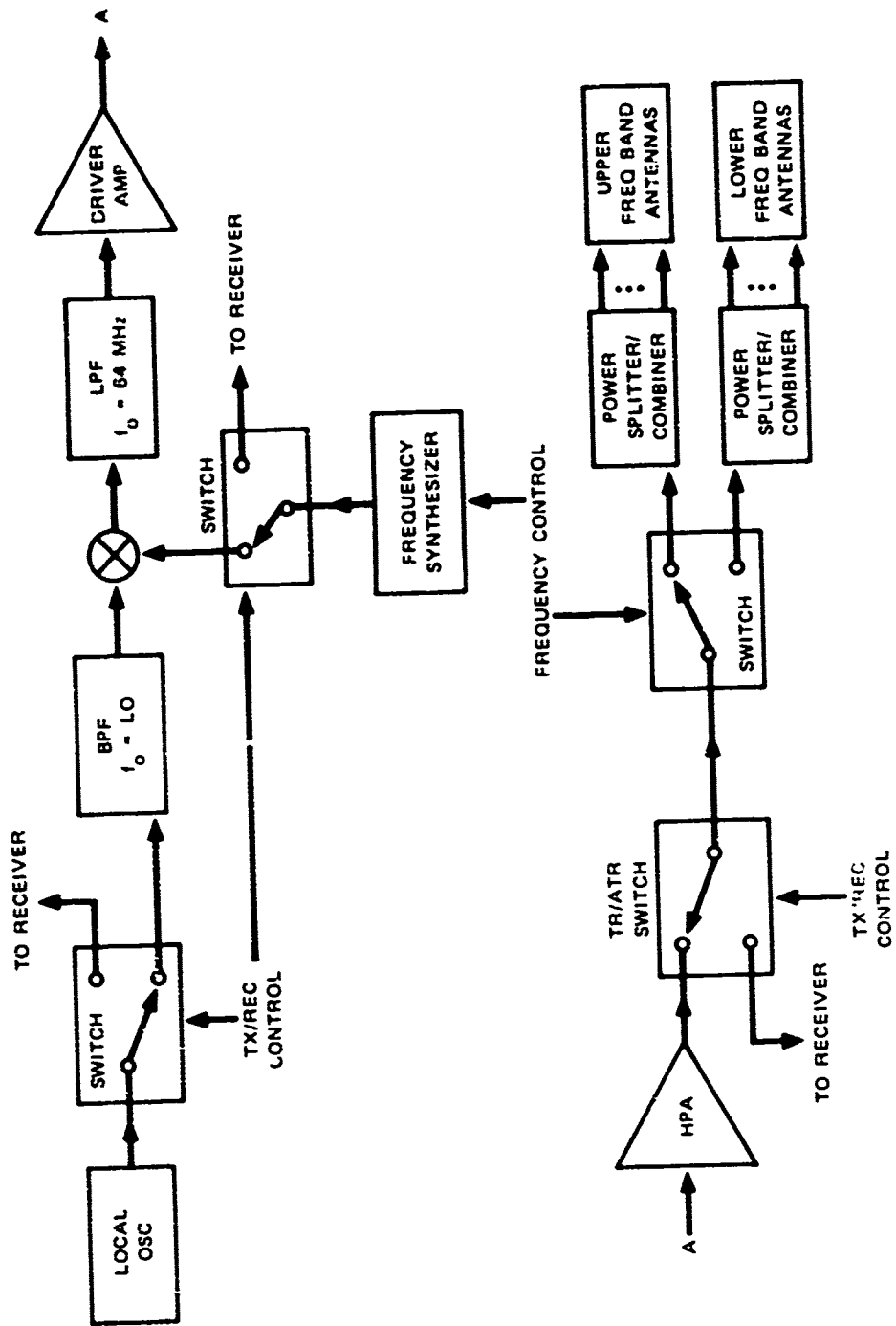

FIGURE 3 TRANSMIT SECTION BLOCK DIAGRAM

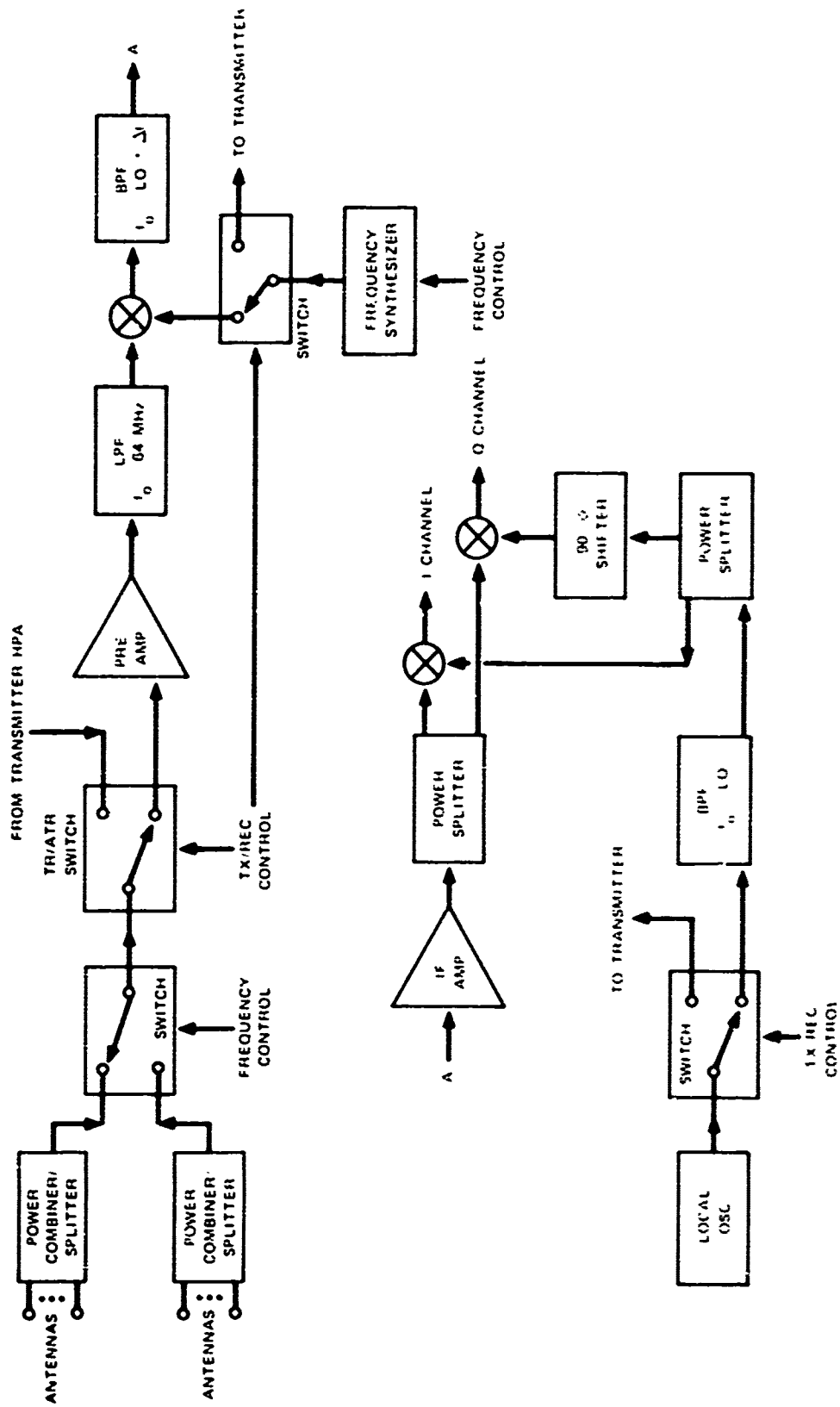

FIGURE 4 RECEIVE SECTION BLOCK DIAGRAM

The control system needs to select:

- Transmit frequency and dwell time
- Transmit antenna (if more than one is used)
- Transmit/receive switch state
- Local oscillator control to transmit/receive sections
- Receiver attenuation level
- Phasing for antenna scanning (if implemented)
- Data sampling commands.

The data acquisition preprocessing and recording system needs to:

- Convert the analog signal to digital data
- Integrate the digital data
- Perform spectral preprocessing
- Record the integrated and preprocessed data
- Record radar system parameter status

The display system needs to:

- Provide display of system operating parameters
- Display real-time returned signal parameters.

2. Design

A block diagram of the proposed system control and data processing elements of the radar are shown in Figure 5. The microprocessor system control unit will send the various control signals. The control unit is driven by a minicomputer. The minicomputer will be programmed to acquire the sampled data, integrate and preprocess the digital data, record the data and system operating parameters, and control the display units. The desired system operation parameters can be entered or changed in the minicomputer via a cassette recorder or a CRT/terminal. SRI International has designed several systems of this type for similar systems.

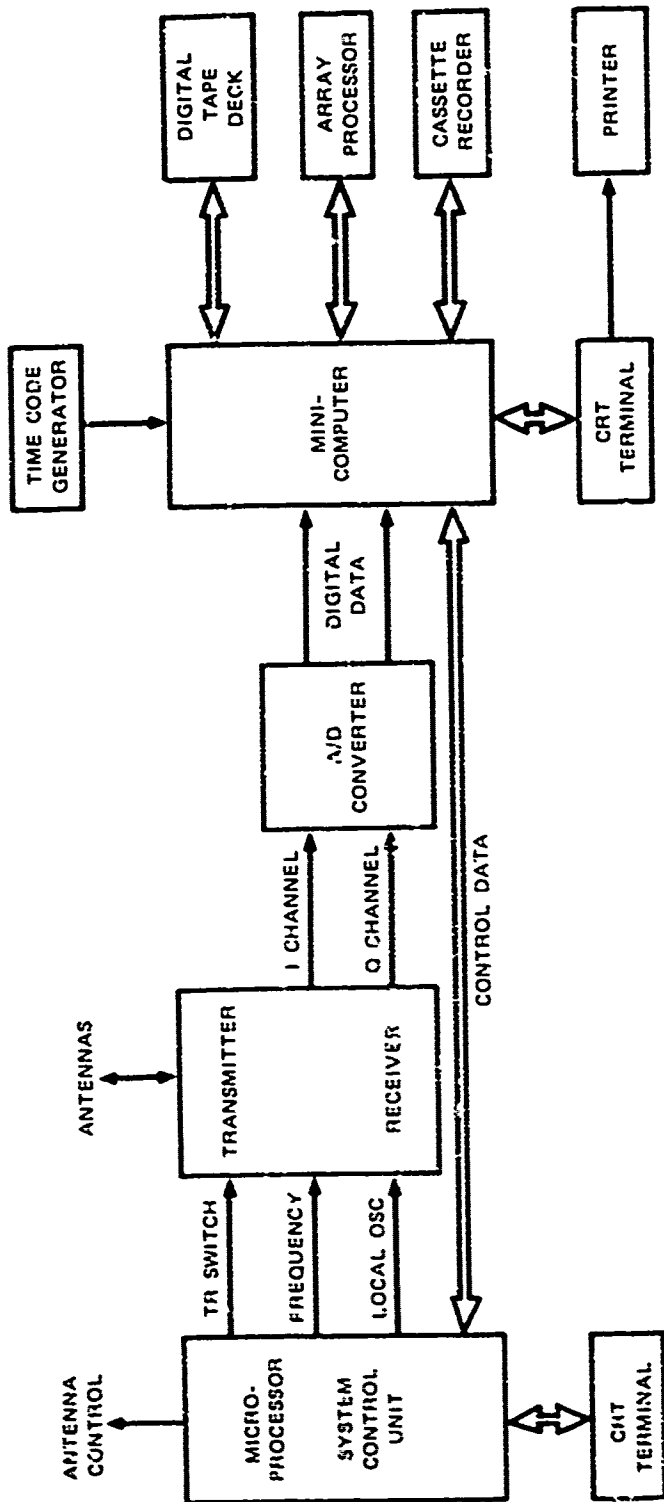

FIGURE 5 SYSTEM CONTROL AND DATA PROCESSING BLOCK DIAGRAM

III SYSTEM COSTS AND RECOMMENDATIONS

We have made a preliminary cost estimate of constructing an operational stepped-frequency radar with the capabilities described in Section II. The cost estimates presented are guidelines based on vendor quotes. Whenever possible, however, Defense Nuclear Agency (DNA) facility equipment presently at SRI International has been included to minimize costs. For example, the Granger Associates HF sounder transmitter, which was used during the LAGOPEDO experiment, can be refurbished for approximately \$20,000, whereas a new Applied Research Corporation HF transmitter will cost approximately \$100,000. We also assume that the Wideband HP 2100 computer systems will be used.

As discussed in Section II.D.2, the HF radar frequency coverage can be advantageously split into two bands: one operating from 24 to 60 MHz and the other from 8 to 24 MHz. The estimated costs of the lower and upper frequency portion antennas are \$75,000 and \$25,000, respectively. We have also estimated the cost of a single log-periodic antenna covering a 2:1 frequency range starting at 32 MHz that can be mechanically steered for broad-area coverage. The estimated hardware costs for the three systems are summarized in Table 1. Costs for the scanning option have not been included in these figures.

In addition to the hardware, approximately eight man-months of labor will be required to assemble, interface, and test the rf components. In addition, approximately eighteen man-months of labor will be required to assemble and test the control, data acquisition, and real-time display system. The manpower costs are summarized in Table 2. The actual costs are based on senior professional and technical/programmer projected hourly rates for 1982.

The initial motivation for developing the stepped-frequency radar was to measure quantitatively the equatorial spread F spectrum through the scale-size regime encompassing the ion gyroradius ($\sim 6 \text{ m}$) where both

Table 1
HARDWARE COSTS

	Frequency Range		
	08 to 64 Mhz	24 to 64 Mhz	32 to 64 Mhz ¹
Antenna system	\$100,000	\$25,000	\$25,000 ¹ \$10,000 ²
Transmitter	5,000	5,000	5,000
Receiver	10,000	10,000	10,000
Data acquisition and control	50,000	50,000	50,000
Total	\$165,000	\$90,000	\$90,000

Table 2
LABOR COSTS

	Frequency Range		
	08 to 64 Mhz	24 to 64 Mhz	32 to 64 Mhz ¹
Antenna system	\$15,000	\$ 10,000	\$5,000
Transmitter	20,000	20,000	20,000
Receiver	25,000	25,000	20,000
Data acquisition and control	150,000	125,000	100,000
Total	\$210,000	\$150,000	\$145,000

¹ Single log-periodic rotatable antenna.

² Electrically rotated.

³ Mechanically rotated.

theory and indirect experimental data suggest a rapid possibly Gaussian decrease in spectral intensity with increasing spatial frequency. Data from the PLUMEX experiment as well as theoretical work to understand the "freezing phenomenon" have shown that spectral steepening begins at much larger wavelengths, perhaps as large as 200 m.

Because these wavelengths are inaccessible to backscatter measurements, the original objectives of the experiment even if fully met will not answer some new questions that have arisen. On the other hand, the broader capabilities of the system discussed in Section I underscore the fact that the capabilities of a stepped-frequency HF backscatter radar with a Doppler processing capability go well beyond the quantitative measurement of the backscatter spatial wavelength spectrum, which is the most difficult measurement to make.

With this in mind, therefore, we have roughly estimated the costs of locating and operating the radar on Roi Namur Island and at a Polar Cap station such as Resolute Bay. The costs are summarized in Table 3. The installation and operating costs are clearly higher for Polar Cap operations. On the other hand, a simple mechanically steerable antenna is adequate for the broad-area surveillance applications of primary interest in the polar cap.

The hardware, labor, and installation costs for placement of the radar either in the arctic or near the equator are summarized in Table 4. Thus, for roughly comparable overall system costs, the basic HF radar system with a limited frequency range can be fielded for operations at the equator or in the polar cap. Moreover, the system capabilities can be expanded as necessary, e.g., completely automated operation may ultimately be desired.

In summary, the stepped-frequency HF radar described in this report is an important diagnostic tool that can serve a variety of data gathering needs that will develop as theoretical refinements and the DNA auroral and polar-cap programs evolve. In short, the costs of the system are justified by the expected results that it will likely generate.

Table 3
INSTALLATION AND OPERATION COSTS

(a) Equatorial Installation

	Frequency		
	05 to 64 MHz	24 to 64 MHz	32 to 64 MHz
Labor	\$50,000	\$30,000	\$25,000
Direct Costs	<u>25,000</u>	<u>20,000</u>	<u>20,000</u>
Total	\$75,000	\$50,000	\$45,000

(b) Arctic Installation

	Frequency		
	05 to 64 MHz	24 to 64 MHz	32 to 64 MHz
Labor	\$150,000	\$90,000	\$75,000
Direct Costs	<u>50,000</u>	<u>40,000</u>	<u>40,000</u>
Total	\$200,000	\$130,000	\$115,000

(c) Operation Costs - Weekly

Labor & Direct Costs	Frequency		
	05 to 64 MHz	24 to 64 MHz	32 to 64 MHz
Equatorial	\$5,000	\$5,000	\$5,000
Arctic	\$6,000	\$6,000	\$6,000

Table 4
COST SUMMARY

(a) Equatorial

	Frequency		
	08 to 64 MHz	24 to 64 MHz	32 to 64 MHz
Hardware	\$165,000	\$90,000	\$90,000
Labor	\$210,000	\$180,000	\$145,000
Installation	\$75,000	\$50,000	\$45,000
Total	<u>\$450,000</u>	<u>\$320,000</u>	<u>\$280,000</u>

(b) Arctic

	Frequency		
	08 to 64 MHz	24 to 64 MHz	32 to 64 MHz
Hardware	\$165,000	\$90,000	\$90,000
Labor	\$210,000	\$180,000	\$145,000
Installation	\$200,000	\$130,000	\$115,000
Total	<u>\$575,000</u>	<u>\$400,000</u>	<u>\$350,000</u>

REFERENCES

- Balsley, B. B., G. Haerendel, and R. A. Greenwald, "Equatorial Spread F: Recent Observations and a New Interpretation," J. Geophys. Res., Vol. 77, No. 28, pp. 5625-5628 (October 1972).
- Chesnut, W. G., private communication.
- Farley, D. T., B. B. Balsley, R. F. Woodman, and J. P. McClure, "Equatorial Spread F: Implications of VHF Radar Observations," J. Geophys. Res., Vol. 75, No. 34, pp. 7199-7216 (December 1970).
- Greenwald, R. A., W. Weiss, E. Nielsen, and N. R. Thomson, "STARE: A New Radar Auroral Backscatter Experiment in Northern Scandinavia," Radio Sci., Vol. 13, No. 6, pp. 1021-1039 (November-December 1978).
- Greenwald, R. A., W. L. Ecklund, and B. B. Balsley, "Auroral Currents, Irregularities and Luminosity," J. Geophys. Res., Vol. 78, No. 34, pp. 8193-8203 (December 1973).
- Sudan, R. N. and M. J. Keskinen, "Theory of Strongly Turbulent Two-Dimensional Convection of Low-Pressure Plasma," Phys. Fluids., Vol. 22, No. 12, pp. 2305-2314 (December 1979).
- Tsunoda, R. T., and R. I. Presnell, "On a Threshold Electric Field Associated with the 398-MHz Diffuse Radar Aurora," J. Geophys. Res., Vol. 81, No. 1, pp. 88-96 (January 1976).
- Tsunoda, R. T., M. J. Baron, J. Owen, and D. M. Towles, "Altair: An Incoherent Scatter Radar for Equatorial Spread F Studies," Radio Sci., Vol. 14, No. 6, pp. 1111-1119 (November-December 1979).
- Tsunoda, R. T., "On the Spatial Relationship of 1-m Equatorial Spread-F Irregularities and Plasma Bubbles," J. Geophys. Res., Vol. 85, No. A1, pp. 185-190 (January 1980).
- Rino, C. L., R. C. Livingston, B. C. Fair, and M. D. Cousins, "Continued Performance of the Wideband Satellite Experiment," Final Report, Contract DNAO91-77-C-0220, SRI Project 6434, SRI International, Menlo Park, CA (June 1980).
- Woodman, R. F. and C. La Hoz, "Radar Observations of F-Region Equatorial Irregularities," J. Geophys. Res., Vol. 81, No. 31, pp. 5447-5466, (November 1976).
- Woodman, R. F. and S. Basu, "Comparison Between in-situ Spectral Measurements of F-Region Irregularities and Backscatter Observations at 3m Wavelengths," Geophys. Res. Letts., Vol. 5, No. 10, pp. 869-872 (October 1978).

DISTRIBUTION LIST

DEPARTMENT OF DEFENSE

Assistant Secretary of Defense
Comm, Cmd, Cont & Intell
ATTN: Dir of Intelligence Sys, J. Babcock

Command & Control Technical Center
ATTN: C-312, R. Mason
ATTN: C-650, G. Jones
3 cy ATTN: C-650, W. Heidig

Defense Communications Agency
ATTN: Code 480
ATTN: Code 480, F. Dieter
ATTN: Code 810, J. Barna
ATTN: Code 205
ATTN: Code 101B

Defense Communications Engineer Center
ATTN: Code R410, N. Jones
ATTN: Code R123

Defense Intelligence Agency
ATTN: DT-5
ATTN: CB-4C, E. O'Farrell
ATTN: DB, A. Wise
ATTN: DT-1P
ATTN: Dir, E. Tighe
ATTN: DC-70, W. Wittig

Defense Nuclear Agency
ATTN: NAFD
ATTN: STRA
ATTN: RAEE
ATTN: NATD
3 cy ATTN: RAEE
4 cy ATTN: TITL

Defense Technical Information Center
12 cy ATTN: DD

Field Command
Defense Nuclear Agency
ATTN: FCP

Field Command
Defense Nuclear Agency
Livermore Branch
ATTN: FCPRL

Interservice Nuclear Weapons School
ATTN: TIV

Joint Chiefs of Staff
ATTN: C3S
ATTN: C3S, Evaluation Office

Joint Strat Tgt Planning Staff
ATTN: JLTW-2
ATTN: JLA

National Security Agency
ATTN: W-32, O. Bartlett
ATTN: B-3, F. Leonard
ATTN: R-52, J. Skillman

DEPARTMENT OF DEFENSE (Continued)

Under Secretary of Defense for Rsch & Engrg
ATTN: Strategic & Space Sys (OS)

WWMCCS System Engineering Org
ATTN: J. Hoff

DEPARTMENT OF THE ARMY

Assistant Chief of Staff for Automation & Comm
Department of the Army
ATTN: DAAC-ZT, P. Kenny

Atmospheric Sciences Laboratory
U.S. Army Electronics R & D Command
ATTN: DELAS-EO, F. Niles

BMD Advanced Technology Center
Department of the Army
ATTN: ATC-T, M. Capps
ATTN: ATC-O, W. Davies

BMD Systems Command
Department of the Army
2 cy ATTN: BMDS-C-HW

Deputy Chief of Staff for Ops & Plans
Department of the Army
ATTN: DAMD-RQC

Harry Diamond Laboratories
Department of the Army
ATTN: DELHD-I-TL, M. Weiner
ATTN: DELHD-N-P, F. Wimentz
ATTN: DELHD-N-RB, R. Williams
ATTN: DELHD-N-P

U.S. Army Chemical School
ATTN: ATZN-CM-CS

U.S. Army Comm-Elec Engrg Instal Agency
ATTN: CCC-EMEO-PED, G. Lane
ATTN: CCC-CED-CCO, W. Neundorf

U.S. Army Communications Command
ATTN: CC-OPS-W
ATTN: CC-OPS-WR, H. Wilson

U.S. Army Communications R&D Command
ATTN: DRDCO-COM-RY, W. Kesselman

U.S. Army Foreign Science & Tech Ctr
ATTN: DRXST-SD

U.S. Army Materiel Dev & Readiness Cmd
ATTN: DRCLDC, J. Bender

U.S. Army Missile Intelligence Agency
ATTN: J. Gamble

U.S. Army Nuclear & Chemical Agency
ATTN: Library

DEPARTMENT OF THE ARMY (Continued)

U.S. Army Satellite Comm Agency
ATTN: Document Control

U.S. Army TRADOC Sys Analysis Actvty
ATTN: ATAA-PL
ATTN: ATAA-TDC
ATTN: ATAA-TCC, F. Payan, Jr

DEPARTMENT OF THE NAVY

COMSPTEVFOR
Department of the Navy
ATTN: Code 605, R. Berg

Joint Cruise Missiles Project Ofc
Department of the Navy
ATTN: JCMG-707

Naval Air Development Center
ATTN: Code 6091, M. Setz

Naval Air Systems Command
ATTN: PMA 271

Naval Electronic Systems Command
ATTN: PME 106-4, S. Kearney
ATTN: PME-117-2013, G. Burnhart
ATTN: PME 117-20
ATTN: Code 3101, T. Hughes
ATTN: Code 501A
ATTN: PME 106-13, T. Griffin
ATTN: PME 117-211, B. Kruger

Naval Intelligence Support Ctr
ATTN: NISC-50

Naval Ocean Systems Center
ATTN: Code 532, J. Bickel
ATTN: Code 5322, M. Paulson
3 cy ATTN: Code 5323, W. Moler
3 cy ATTN: Code 5323, J. Ferguson

Naval Research Laboratory
ATTN: Code 7550, J. Davis
ATTN: Code 4187
ATTN: Code 4780, S. Ossakow
ATTN: Code 7500, B. Wald
ATTN: Code 7950, J. Goodman
ATTN: Code 4700, T. Coffey

Naval Space Surveillance System
ATTN: J. Burton

Naval Surface Weapons Center
ATTN: Code F31

Naval Telecommunications Command
ATTN: Code 341

Office of Naval Research
ATTN: Code 465
ATTN: Code 420
ATTN: Code 421

Office of the Chief of Naval Operations
ATTN: OP 65
ATTN: OP 941D
ATTN: OP 981N

DEPARTMENT OF THE NAVY (Continued)

Strategic Systems Project Office
Department of the Navy
ATTN: NSP-2722, F. Wimberly
ATTN: NSP-2141
ATTN: NSP-43

DEPARTMENT OF THE AIR FORCE

Aerospace Defense Command
Department of the Air Force
ATTN: DC, T. Long

Air Force Geophysics Laboratory
ATTN: OPR, H. Gardiner
ATTN: OPR-1
ATTN: LKB, K. Champion
ATTN: OPR, A. Stair
ATTN: S. Basu
ATTN: PHP
ATTN: PH1, J. Buchau
ATTN: R. Thompson

Air Force Weapons Laboratory
Air Force Systems Command
ATTN: SUL
ATTN: NTYC
ATTN: NTN

Air Force Wright Aeronautical Lab
ATTN: W. Hunt
ATTN: A. Johnson

Air Logistics Command
Department of the Air Force
ATTN: OO-ALC/MM

Air University Library
Department of the Air Force
ATTN: AUL-LSE

Air Weather Service, MAC
Department of the Air Force
ATTN: DMXP, R. Bahcock

Assistant Chief of Staff
Studies & Analyses
Department of the Air Force
ATTN: AF/SASC, W. Keaus
ATTN: AF/SASC, C. Rihmeyer

Ballistic Missile Office
Air Force Systems Command
ATTN: ENSN, J. Allen

Deputy Chief of Staff
Operations Plans and Readiness
Department of the Air Force
ATTN: AFXOXFD
ATTN: AFXOXT
ATTN: AFXOXCD
ATTN: AFXOKS

Deputy Chief of Staff
Research, Development, & Acq
Department of the Air Force
ATTN: AFRDS
ATTN: AFRDSP
ATTN: AFRDSS

DEPARTMENT OF THE AIR FORCE (Continued)

Electronic Systems Division
ATTN: XRW, J. Deas

Electronic Systems Division
ATTN: YSEA
ATTN: YSM, J. Kobelski

Foreign Technology Division
Air Force Systems Command
ATTN: TQTD, B. Gallard
ATTN: NIIS, Library

Headquarters Space Division
Air Force Systems Command
ATTN: SKA, D. Bolin
ATTN: SKY, C. Kennedy

Headquarters Space Division
Air Force Systems Command
ATTN: YZJ, W. Mercer

Headquarters Space Division
Air Force Systems Command
ATTN: E. Butt

Rome Air Development Center
Air Force Systems Command
ATTN: EEP

Strategic Air Command
Department of the Air Force
ATTN: DCXT
ATTN: NRT
ATTN: DCXR, T. Jorgensen
ATTN: DCX
ATTN: XPFS

Electronic Systems Division
ATTN: DCKC, J. Clark

Rome Air Development Center
Air Force Systems Command
ATTN: UCS, V. Coyne
ATTN: TSLF

OTHER GOVERNMENT AGENCIES

Central Intelligence Agency
ATTN: OSAR/SED

Department of Commerce
National Bureau of Standards
ATTN: Sec Ofc for R. Moore

Department of Commerce
National Oceanic & Atmospheric Admin
ATTN: R. Grubb

Institute for Telecommunications Sciences
National Telecommunications & Info Admin
ATTN: A. Jean
ATTN: L. Berry
ATTN: W. Ullaut

U.S. Coast Guard
Department of Transportation
ATTN: G-DOE-3/TP54, B. Romine

DEPARTMENT OF ENERGY CONTRACTORS

EG&G, Inc
ATTN: D. Wright
ATTN: J. Colvin

Lawrence Livermore National Lab
ATTN: L-389, E. Ott
ATTN: L-3J, R. Hager
ATTN: Technical Info Dept, Library

Los Alamos National Laboratory
ATTN: MS 664, J. Zinn
ATTN: D. Simons
ATTN: P. Keaton
ATTN: D. Westervelt
ATTN: E. Jones
ATTN: R. Taschek
ATTN: MS 670, J. Hopkins

Sandia National Laboratories
Livermore Laboratory
ATTN: B. Murphey
ATTN: T. Cook

Sandia National Lab
ATTN: Org 1250, W. Brown
ATTN: Org 4241, T. Wright
ATTN: Space Project Div
ATTN: 3141
ATTN: D. Thornbrough
ATTN: D. Dahlgren

DEPARTMENT OF DEFENSE CONTRACTORS

Aerospace Corp
ATTN: I. Garfunkel
ATTN: R. Slaughter
ATTN: D. Olsen
ATTN: J. Straus
ATTN: T. Salmi
ATTN: V. Josephson
ATTN: S. Bower
ATTN: N. Stockwell

University of Alaska
ATTN: T. Davis
ATTN: M. Brown
ATTN: Technical Library

Analytical Systems Engineering Corp
ATTN: Radio Sciences

Analytical Systems Engineering Corp
ATTN: Security

Barry Research Corporation
ATTN: J. McLaughlin

BDM Corp
ATTN: L. Jacobs
ATTN: T. Neighbors

Berkeley Research Associates, Inc
ATTN: J. Workmen

Betac
ATTN: J. Hirsch

DEPARTMENT OF DEFENSE CONTRACTORS (Continued)

Boeing Co
ATTN: M/S 42-33, J. Kennedy
ATTN: G. Hall
ATTN: S. Tashird

Booz-Allen & Hamilton, Inc
ATTN: B. Wilkinson

University of California at San Diego
ATTN: H. Booker

Charles Stark Draper Lab, Inc
ATTN: J. Gilmore
ATTN: D. Cox

Communications Satellite Corp
ATTN: D. Fang

Comsat Labs
ATTN: R. Taur
ATTN: G. Hyde

Cornell University
ATTN: M. Kelly
ATTN: D. Farley, Jr

E-Systems, Inc
ATTN: R. Berezdivin

ElectroSpace Systems, Inc
ATTN: H. Logston

ESL, Inc
ATTN: J. Marshall

General Electric Co
ATTN: M. Bortner
ATTN: A. Harcar

General Electric Co
ATTN: A. Steinmayer
ATTN: C. Zierdt

General Electric Co
ATTN: F. Reibert

General Electric Co
ATTN: G. Hillman

General Research Corp
ATTN: J. Ise, Jr
ATTN: J. Garbarino

Harris Corp
ATTN: E. Knick

Horizons Technology, Inc
ATTN: R. Kruger

HSS, Inc
ATTN: D. Hansen

IBM Corp
ATTN: F. Ricci

University of Illinois
ATTN: K. Yeh

DEPARTMENT OF DEFENSE CONTRACTORS (Continued)

Institute for Defense Analyses
ATTN: J. Bengston
ATTN: E. Bauer
ATTN: H. Wolfhard
ATTN: J. Aein

International Tel & Telegraph Corp
ATTN: G. Wetmore
ATTN: Technical Library

JAYCOR
ATTN: J. Sperling

JAYCOR
ATTN: J. DonCarlos

Johns Hopkins University
ATTN: T. Potemra
ATTN: J. Phillips
ATTN: T. Evans
ATTN: J. Newland
ATTN: P. Komiske

Kaman Tempo
ATTN: DASIAC
ATTN: W. McNamara
ATTN: T. Stephens
ATTN: W. Knapp

Linkabit Corp
ATTN: I. Jacobs

Litton Systems, Inc
ATTN: R. Grasty

Lockheed Missiles & Space Co, Inc
ATTN: W. Imhof
ATTN: M. Walt
ATTN: R. Johnson

Lockheed Missiles & Space Co, Inc
ATTN: Dept 60-12

M.I.T. Lincoln Lab
ATTN: D. Towle

Martin Marietta Corp
ATTN: R. Heffner

McDonnell Douglas Corp
ATTN: G. Mroz
ATTN: N. Harris
ATTN: W. Olson
ATTN: J. Moule
ATTN: R. Halprin

Meteor Communications Consultants
ATTN: R. Leader

Mission Research Corp
ATTN: S. Gutsche
ATTN: R. Hendrick
ATTN: Tech Library
ATTN: R. Bogusch
ATTN: R. Kilb
ATTN: D. Sappenfield
ATTN: F. Fajen

DEPARTMENT OF DEFENSE CONTRACTORS (Continued)

Mitre Corp

ATTN: G. Harding
ATTN: A. Kyziel
ATTN: B. Adams
ATTN: C. Callahan

Mitre Corp

ATTN: W. Hall
ATTN: M. Horrocks
ATTN: J. Wheeler
ATTN: W. Foster

Pacific-Sierra Research Corp

ATTN: E. Field, Jr
ATTN: H. Brode
ATTN: F. Thomas

Pennsylvania State University

ATTN: Ionospheric Research Lab

Photometrics, Inc

ATTN: I. Kofsky

Physical Dynamics, Inc

ATTN: E. Frenouw

Physical Research, Inc

ATTN: R. Deliberis

R & D Associates

ATTN: H. Ory
ATTN: B. Gebbarc
ATTN: M. Gantsweg
ATTN: F. Gilmore
ATTN: C. Greifinger
ATTN: W. Karzas
ATTN: R. Turco
ATTN: W. Wright
ATTN: R. Lelevier
ATTN: P. Haas

R & D Associates

ATTN: B. Yoon

Rand Corp

ATTN: C. Crain
ATTN: E. Bedrozian

Riverside Research Institute

ATTN: V. Trapani

Rockwell International Corp

ATTN: R. Buckner

DEPARTMENT OF DEFENSE CONTRACTORS (Continued)

Rockwell International Corp

ATTN: S. Quilici

Santa Fe Corp

ATTN: D. Paolucci

Science Applications, Inc

ATTN: L. Linson
ATTN: C. Smith
ATTN: E. Straker
ATTN: D. Hamlin

Science Applications, Inc

ATTN: SZ

Science Applications, Inc

ATTN: J. Cockayne

SRI International

ATTN: W. Jaye
ATTN: R. Leadabrand
ATTN: D. Neilson
ATTN: R. Livingston
ATTN: R. Tsunoda
ATTN: G. Smith
ATTN: G. Price
ATTN: M. Baron
ATTN: A. Burns
4 cy ATTN: C. Rino
4 cy ATTN: J. Petrickes
4 cy ATTN: W. Chesnut

Sylvania Systems Group

ATTN: M. Cross

Technology International Corp

ATTN: W. Boquist

Tri-Com, Inc

ATTN: D. Murray

TRW Defense & Space Sys Group

ATTN: D. Dee
ATTN: R. Plebuch

Utah State University

ATTN: J. Dupnik
ATTN: K. Baker
ATTN: L. Jensen

Visidyne, Inc

ATTN: C. Humphrey
ATTN: J. Carpenter