

AD-A107 814

ARMY ARMAMENT RESEARCH AND DEVELOPMENT COMMAND DOVER--ETC F/6 14/5
X-RAY SCANNING METHOD FOR DETECTION OF GAPS IN ASSEMBLED TANK A--ETC(U)
NOV 81 E G BARNES, G DRUCKER

UNCLASSIFIED

ARPAD-TR-81002

SBIE-AD-E400 731

NL

1 OF 1
ADA
07814



h

AD A107814

LEVEL III

12

AD

AD-E400 731

TECHNICAL REPORT ARPAD-TR-81002

**X-RAY SCANNING METHOD FOR DETECTION
OF
GAPS IN ASSEMBLED TANK AMMUNITION**

**EMMETT G. BARNES
GEORGE DRUCKER**

**DTIC
ELECTE
NOV 27 1981
S D
E**

NOVEMBER 1981



**US ARMY ARMAMENT RESEARCH AND DEVELOPMENT COMMAND
PRODUCT ASSURANCE DIRECTORATE
DOVER, NEW JERSEY**

DTIC FILE COPY

APPROVED FOR PUBLIC RELEASE; DISTRIBUTION UNLIMITED.

81 11 26 016

The views, opinions, and/or findings contained in this report are those of the author(s) and should not be construed as an official Department of the Army position, policy, or decision, unless so designated by other documentation.

Destroy this report when no longer needed. Do not return it to the originator.

UNCLASSIFIED

SECURITY CLASSIFICATION OF THIS PAGE (When Data Entered)

| REPORT DOCUMENTATION PAGE | | READ INSTRUCTIONS BEFORE COMPLETING FORM |
|--|-------------------------------------|--|
| 1. REPORT NUMBER Technical Report ARPAD-TR-81002 | 2. GOVT ACCESSION NO. DDA107 814 | 3. RECIPIENT'S CATALOG NUMBER |
| 4. TITLE (and Subtitle) X-RAY SCANNING METHOD FOR DETECTION OF GAPS IN ASSEMBLED TANK AMMUNITION | | 5. TYPE OF REPORT & PERIOD COVERED Final |
| | | 6. PERFORMING ORG. REPORT NUMBER |
| 7. AUTHOR(s) Emmett G. Barnes George Drucker | | 8. CONTRACT OR GRANT NUMBER(s) |
| 9. PERFORMING ORGANIZATION NAME AND ADDRESS ARRADCOM, PAD Technology and Automation, Information and Mathematics Div (DRDAR-QAS) Dover, NJ 07801 | | 10. PROGRAM ELEMENT, PROJECT, TASK AREA & WORK UNIT NUMBERS |
| 11. CONTROLLING OFFICE NAME AND ADDRESS ARRADCOM, TSD STINFO Div (DRDAR-TSS) Dover, NJ 07801 | | 12. REPORT DATE November 1981 |
| | | 13. NUMBER OF PAGES 20 |
| 14. MONITORING AGENCY NAME & ADDRESS (if different from Controlling Office) | | 15. SECURITY CLASS. (of this report) Unclassified |
| | | 15a. DECLASSIFICATION/DOWNGRADING SCHEDULE |
| 16. DISTRIBUTION STATEMENT (of this Report) Approved for public release; distribution unlimited. | | |
| 17. DISTRIBUTION STATEMENT (of the abstract entered in Block 20, if different from Report) | | |
| 18. SUPPLEMENTARY NOTES This project was funded by the U.S. Army Armament Materiel Readiness Command (ARRCOM), Dover, NJ. | | |
| 19. KEY WORDS (Continue on reverse side if necessary and identify by block number) Ammunition inspection Radiography Gap detection Tank ammunition In-motion radiography X-ray film Nondestructive testing X-ray inspection Radiographic scanning X-ray scanning | | |
| 20. ABSTRACT (Continue on reverse side if necessary and identify by block number) A problem involving the detection of gaps between mating metal parts in 90-millimeter tank ammunition projectiles has been solved using a novel radiographic technique that requires scanning the projectile and X-ray film during X-ray exposure. The difficulties precluding the use of conventional approaches, as well as details of the successful technique, are described in the report. This method was developed specifically for screening fully assembled cartridges in the stockpile and is capable of moderate production rates. | | |

DD FORM 1 JAN 73 1473

EDITION OF 1 NOV 65 IS OBSOLETE

UNCLASSIFIED

SECURITY CLASSIFICATION OF THIS PAGE (When Data Entered)

SECURITY CLASSIFICATION OF THIS PAGE(When Data Entered)

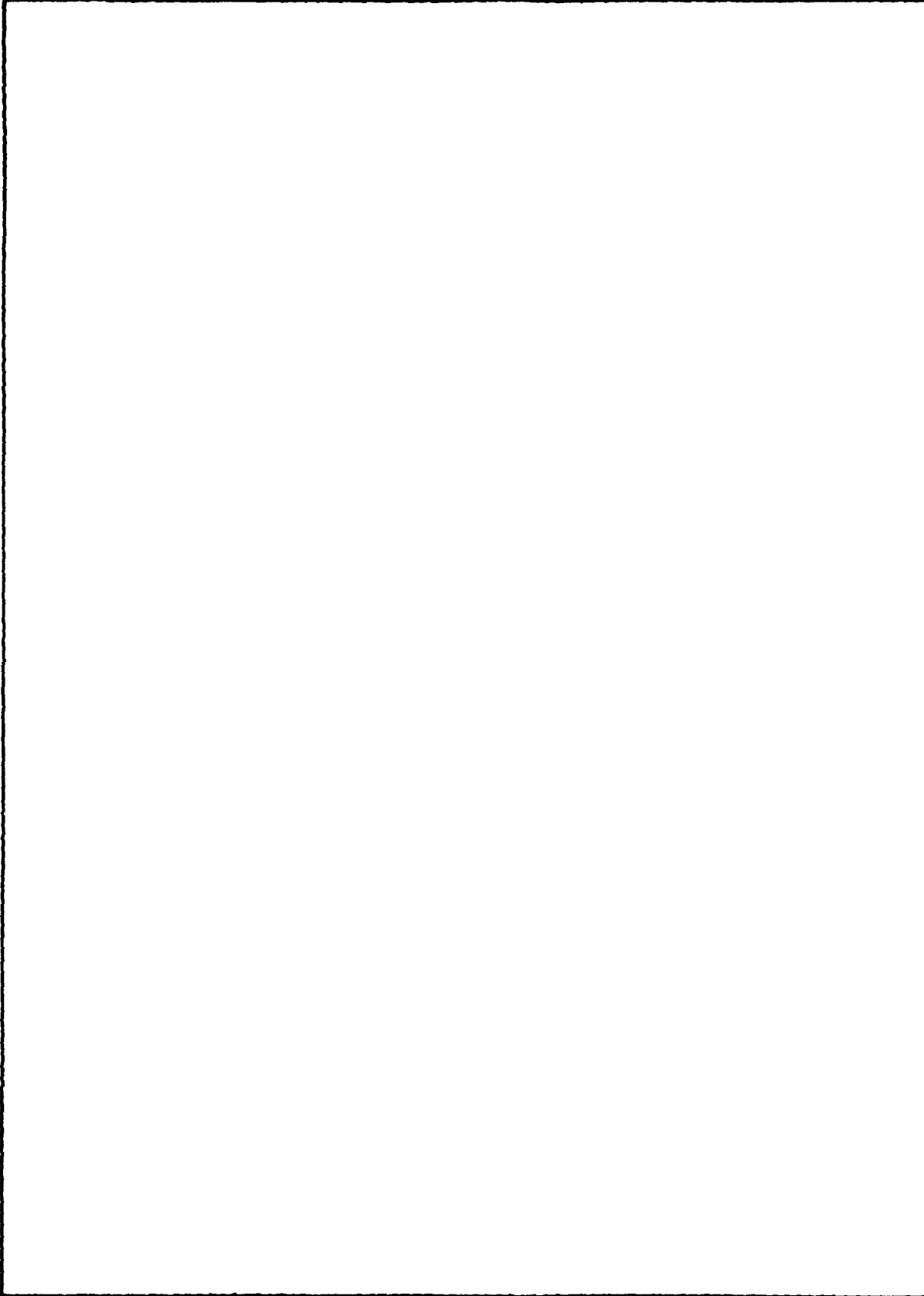

SECURITY CLASSIFICATION OF THIS PAGE(When Data Entered)

ACKNOWLEDGMENT

The authors gratefully acknowledge the support and technical expertise of Peter Shaw of the Ammunition Maintenance Engineering Branch A, U.S. Army Armament Materiel Readiness Command (ARRCOM), Dover, NJ.

| | |
|---------------|---------|
| Accession For | |
| NTIS CLASS | X |
| DTIC CLASS | |
| AD | |
| For | |
| DTIC | |
| AD | Codes |
| Dist | /or |
| A | Special |

CONTENTS

| | Page |
|-------------------------------------|------|
| Introduction | 1 |
| Inspection Problem | 1 |
| Experimental Radiographic Technique | 2 |
| Conclusions and Recommendations | 3 |
| Distribution List | 15 |

TABLE

| | |
|---------------------------------------|---|
| 1 Experimental radiographic technique | 5 |
|---------------------------------------|---|

FIGURES

| | |
|---|----|
| 1 90-mm HEAT-T cartridge M431 | 6 |
| 2 90-mm projectile M431 | 7 |
| 3 Projectile segment without obturating band | 8 |
| 4 End view of projectile at the gap plane | 9 |
| 5 X-ray scanner for 90-mm cartridge M431 | 10 |
| 6 Photographs of radiographs showing gap area | 11 |
| 7 Enlarged view of gap area, cartridge M431 | 12 |
| 8 Sketch of self-contained X-ray scanning system for 90-mm cartridge inspection | 13 |

INTRODUCTION

Radiography is routinely used for inspection of large quantities of U.S. Army artillery and tank ammunition during Research and Development (R&D) and manufacture to assure integrity of materials and proper assembly of parts. In addition, radiography has frequently been found effective in screening stockpile ammunition to detect and cull out items having defects not anticipated at the time of manufacture. Such screening operations are often critical to the safe use of the ammunition in training or actual combat operations.

When it became evident that certain 90-mm tank ammunition (HEAT-T M431) might be defective because a gap could exist between the mating faces of the aluminum chamber and the steel warhead (they might not be completely screwed together), a simple but reliable inspection technique was required. The metal feeler gauge method used during manufacture was not appropriate since the gauge could not be inserted past the plastic obturating band after the cartridge case had been crimped onto the warhead assembly. The cartridge case has a tendency to hold the obturating band forward against the rear face of the steel warhead (figs. 1 and 2). Radiography seemed to be the natural choice for the inspection, since penetration of the plastic band by an X-ray beam could be easily accomplished.

INSPECTION PROBLEM

Careful consideration revealed that straightforward radiographic procedures would not be reliable for this application because of the small gaps that had required detection. (Gap detectability down to 0.001 to 0.002 inch was essential.) To be effective, the energy of the X-ray beam would have to be selected low enough that there would be virtually no penetration of the steel or aluminum, but there would be substantial penetration of the plastic band. Precise alignment of the X-ray beam with the plane of the gap would be required (fig. 3). A slight misalignment would result in the beam's being cut off completely by the metal on either side of the gap, and would make a shell with a small gap appear to have no gap. Avoidance of such a "false acceptable" indication is of paramount importance.

Several possible sources of beam misalignment can occur in the industrial environment anticipated for the X-ray operation:

1. Inconsistent positioning of shell: It was expected that the shell would be manually placed into a simple fixture that automatically registers on the gap area. However, the need for speed would preclude a very tight fit with the fixture. This, combined with dimensional tolerances in the shell and wear on the fixture, would allow only approximate positioning compared to the dimensions of the smallest gaps (0.001 in.).

2. Imprecise alignment of the cartridge case: The assembly and crimping of the cartridge case to the projectile is not precise. It would be necessary to partially support the shell under the cartridge case, thereby presenting the possibility of slight tilting of the axis relative to the X-ray beam.

3. Difficulty in locating the exact position of the X-ray source within the X-ray tube head: Position of the source is not a closely controlled factor in the manufacture and assembly of X-ray equipment, although the source can be located by some trial-and-error procedures with special test objects and a series of X-ray exposures. However, once established, there would be no assurance that the head would remain precisely fixed during any required maintenance of the equipment or unforeseen vibrations.

EXPERIMENTAL RADIOGRAPHIC TECHNIQUE

To overcome the X-ray beam alignment problem and to insure that no shell with gaps would appear acceptable, an X-ray scanning or "in-motion" radiographic technique was developed. This required translating the shell longitudinally (along its axis) while exposing the area of possible gap to a non-moving X-ray source located some distance above the plane of the shell (figs. 4 and 5). The film was placed below the shell (opposite the source) and translated with the shell. The success of this method depends on proper selection of the X-ray energy and of the scanning speed. An excessively slow scan or high X-ray energy could cause continuous film exposure or blurring in the gap zone due to penetration or scatter, and would result in obliteration of any gap image. Having the X-ray energy too low or scanning too fast would provide inadequate penetration and no gap detection. The proper combination of parameters allows the film to "see" the X-ray source only if a gap is present and only during the very short interval when the plane of the gap is scanning across the X-ray source.

Since X-ray sources are small in size (one-to-two millimeter diameter), it was necessary to scan slowly. The X-ray equipment, selected experimentally for this application, was a Philips MG-150 unit having a dual focus (dual source) beryllium window X-ray tube. The larger (2.5 mm) source was used since it provided higher X-ray intensity resulting in minimum scan time. An X-ray energy of 50 kilovolts (constant potential) and Kodak type M film in the pre-packaged lead pack produced excellent images of gaps down to 0.001 inch without significant interference from X-ray scattering or undercutting. (Table 1 lists other radiographic technique parameters.) Mechanical scanning of the shell was provided by an existing remote controlled X-Y traverse mechanism adjusted to a scan rate of one inch per minute along one axis. Since the source was only 2.5 mm (0.098 in.) across, the exposure time available through a very small gap was only about 0.098 minute or 5.9 seconds. This was sufficient time for good film exposures with the source-to-film distance of 12 inches and X-ray tube current at 20 milliamperes. A reduction in scan time to one minute with acceptable exposure was achieved by increasing the scan rate to two inches per minute.

CONCLUSIONS AND RECOMMENDATIONS

As seen in the radiographs (figs. 6 and 7), the distinction between a gap and no-gap condition is quite clear. We now consider this technique ready for adaptation to production inspection of stockpiled ammunition either in the laboratory or at field locations. The concept is illustrated in figure 5. Future efforts should concentrate on improving the engineering design of the equipment and optimization of techniques for economy. The principal need is for a more rugged, semi-automatic, scanning and indexing fixture. An X-ray shielding box with rapid access for loading and unloading will be needed if a field operation is to be conducted (fig. 8). Improved material handling devices and a more economical film may be possible. A self-checking X-ray alignment standard will be required. Application of this technique to inspection of other ammunition items must await further feasibility studies.

Table 1. Experimental radiographic technique

Equipment: Philips MG-150 (constant potential)
X-ray Source: 2.5 millimeter focus; beryllium window tube
X-ray Energy: 50 kilovolts
Tube Current: 20 milliamps
Source to Film Distance: 12 inches
Film: Kodak M, Lead Pack

| <u>Scan time</u> | <u>Exposure time through 0.001-in. gap</u> |
|---------------------------------|--|
| 2 minutes at 1 inch per minute | 5.9 seconds |
| 1 minute at 2 inches per minute | 2.9 seconds |

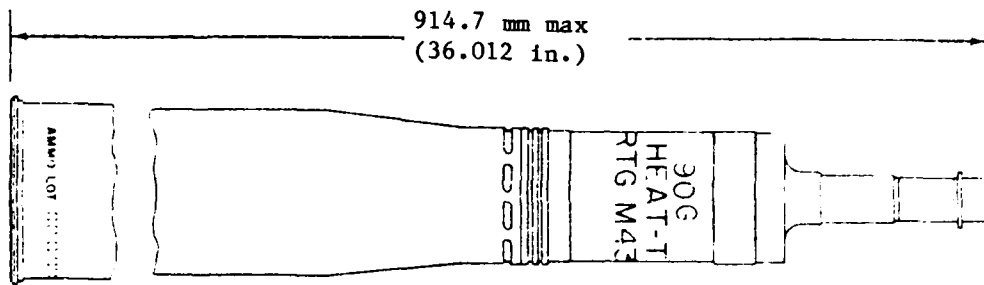

AR199837

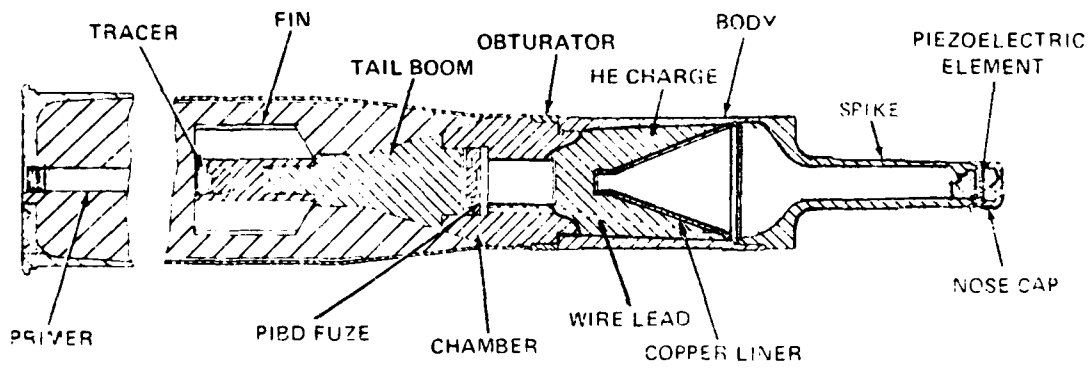

AR199836

Figure 1. 90-mm HEAT-T cartridge M431

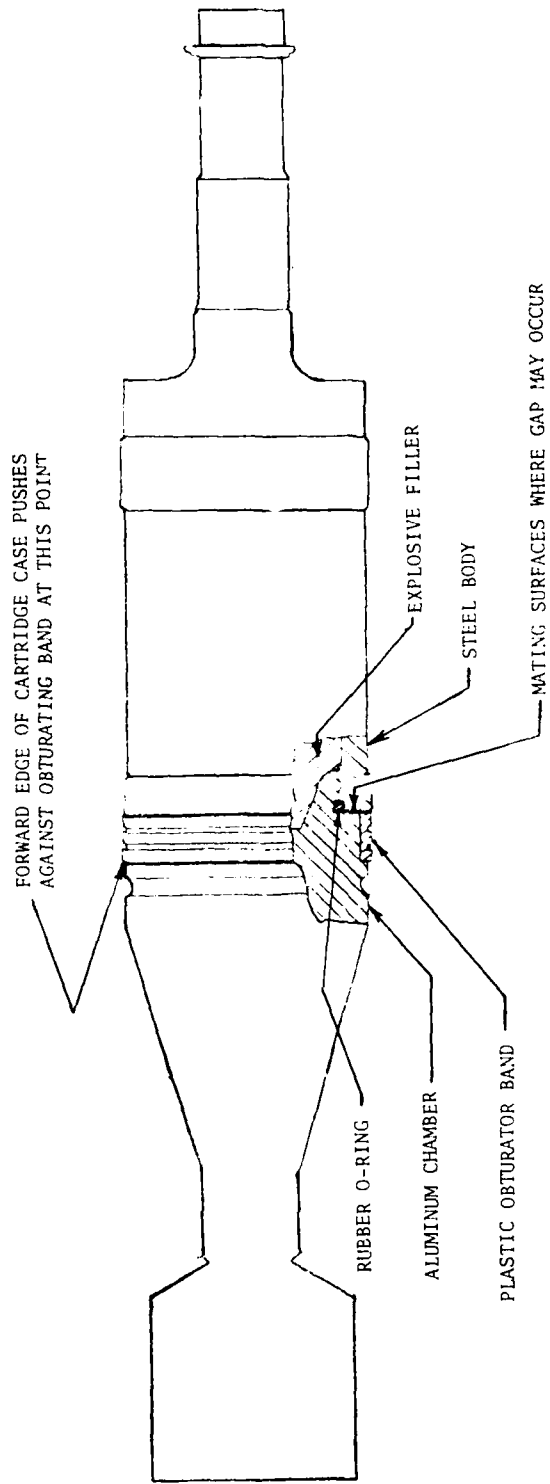

Figure 2. 90-mm projectile M431

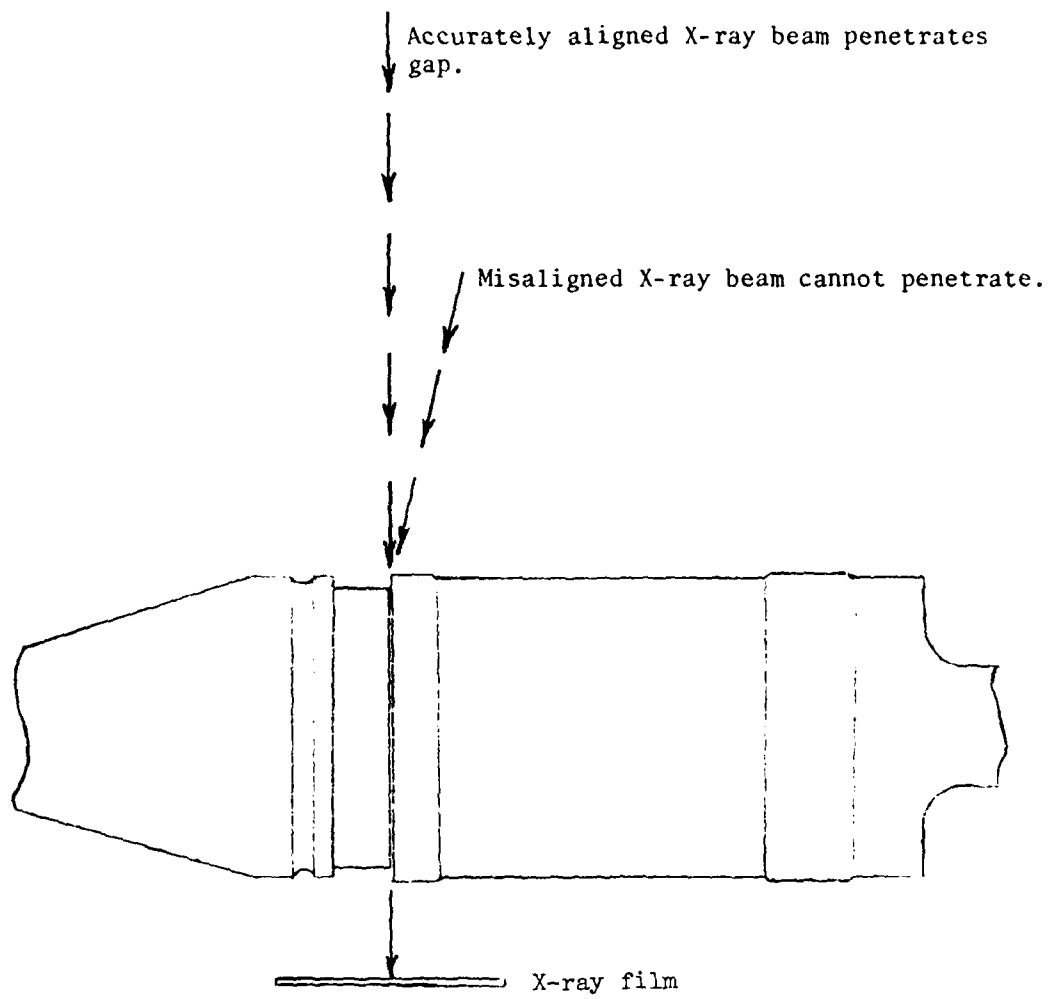

Figure 3. Projectile segment without obturating band

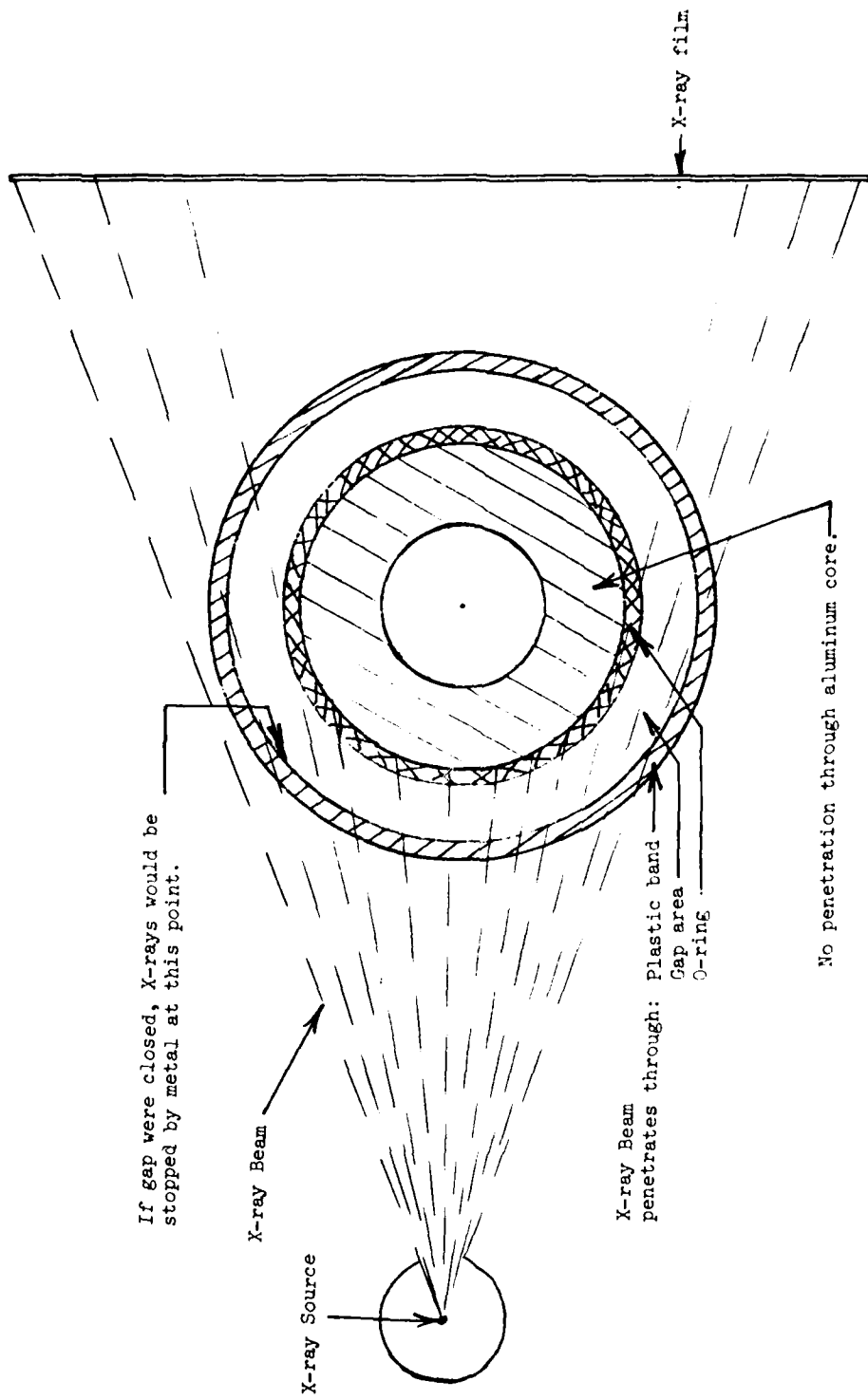
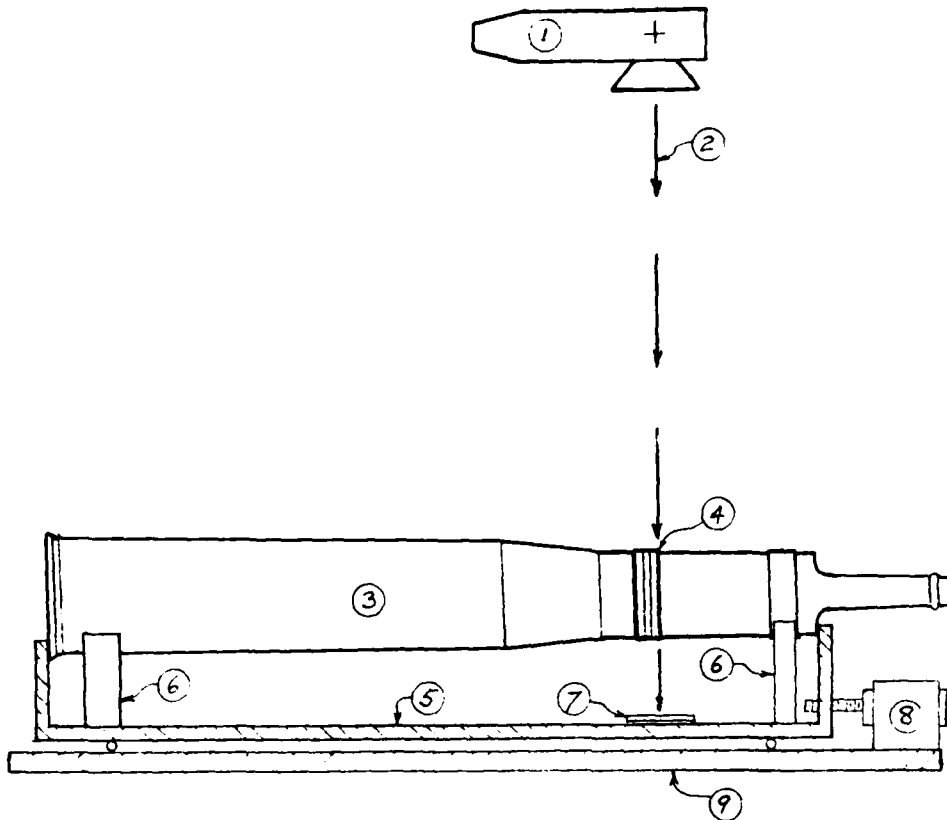

Figure 4. End view of projectile at the gap plane



1. X-ray tube head (source)
2. X-ray beam
3. 90-mm HEAT-T cartridge M431 (complete round)
4. Gap area (interface between body and chamber)
5. Sliding fixture (aluminum) with end brackets to position shell longitudinally
6. V-blocks (aluminum) mounted on sliding fixture to position shell vertically and laterally
7. X-ray film cassette
8. Reversible drive motor with precision lead screw to move sliding fixture at 2 inches per minute
9. Support base or table (aluminum)

Figure 5. X-ray scanner for 90-mm cartridge M431

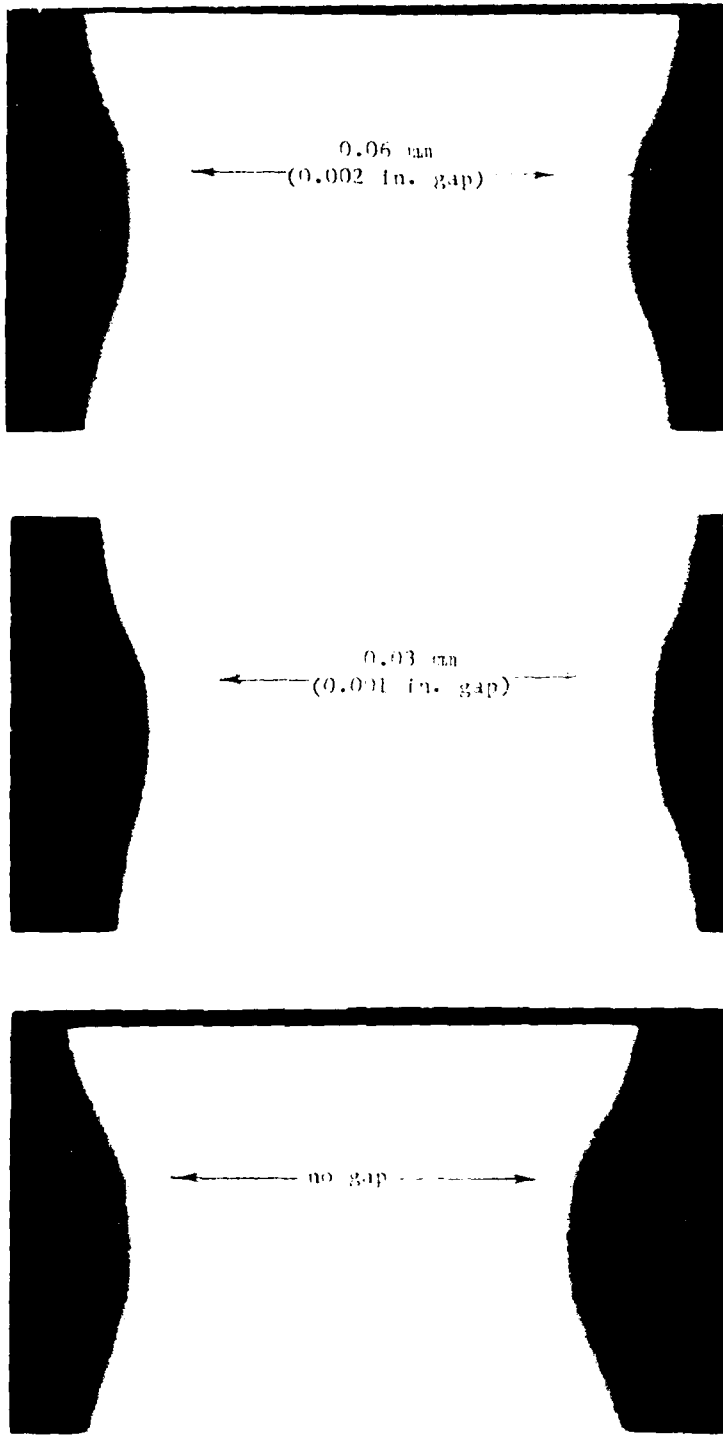

Figure 6. Photographs of radiographs showing gap area

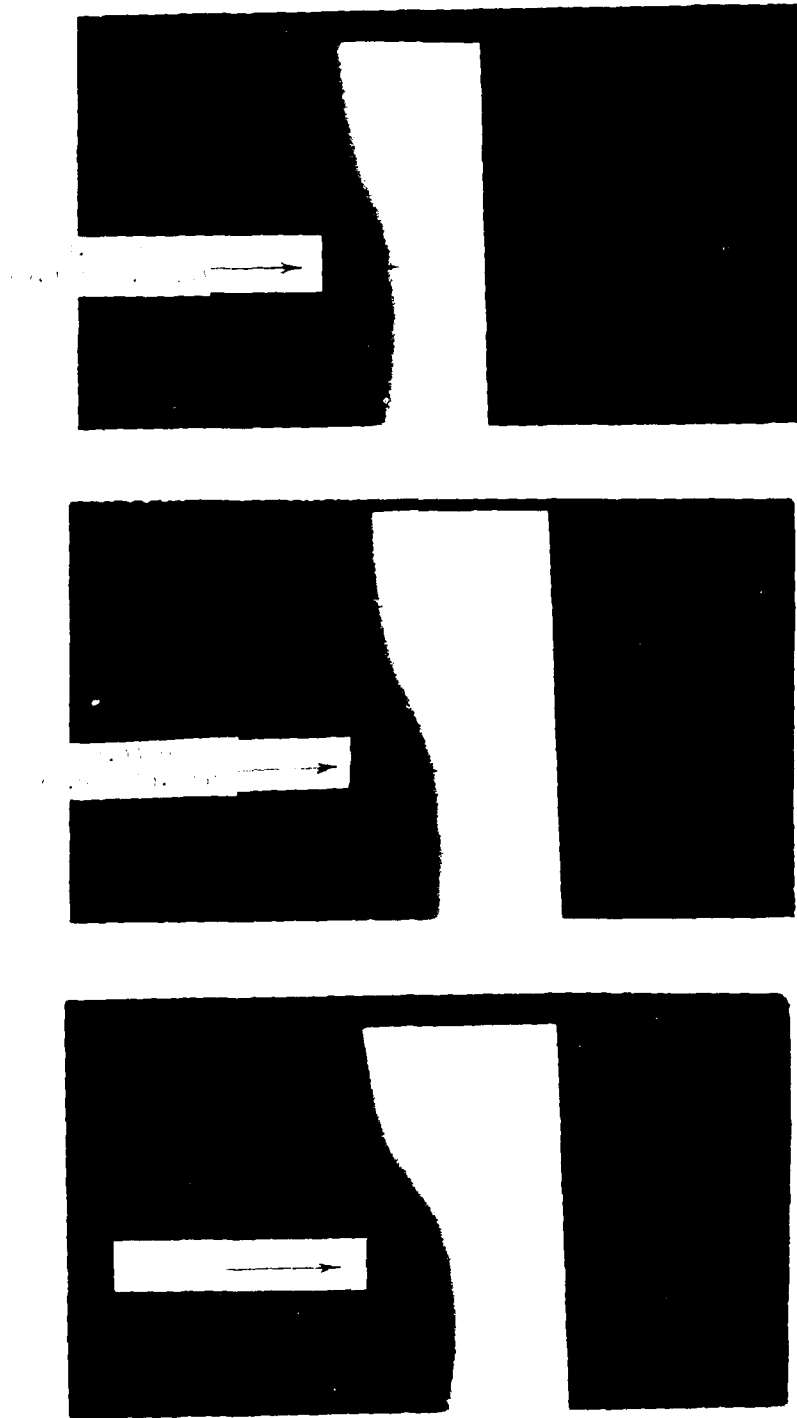

Figure 7. Enlarged view of gap area, cartridge M431

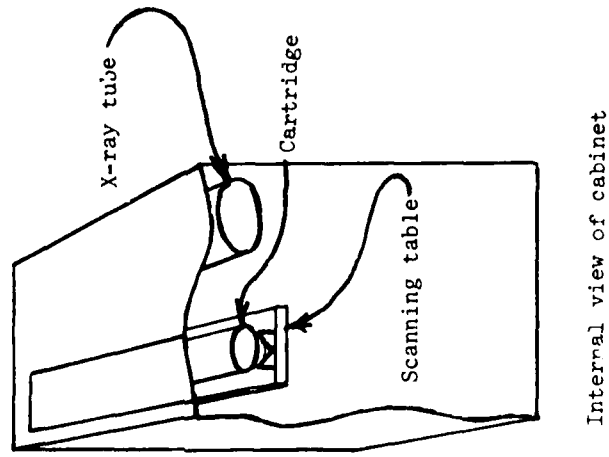
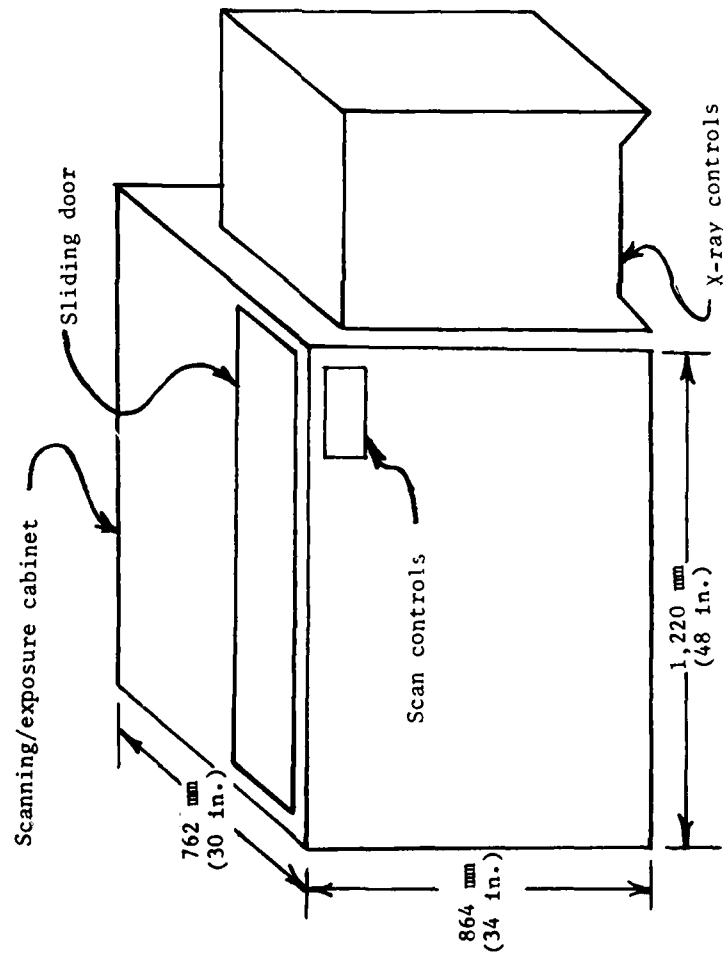

Figure 8. Sketch of self-contained X-ray scanning system for 90-mm cartridge inspection

DISTRIBUTION LIST

Commander
U.S. Army Armament Research
and Development Command
ATTN: DRDAR-QAR-R
DRDAR-QAR-I, M. Weinberg
DRDAR-QAR-Q
DRDAR-QAS
DRDAR-QAS-T, E. Barnes (10)
B. Aronowitz
DRDAR-QAT-A
DRDAR-QAT-I
DRDAR-QAT-B
DRDAR-LCR-E
DRDAR-LCR-Q
DRDAR-TSS (5)
DRDAR-GCL
Dover, NJ 07801

Commander
U.S. Army Munitions Production
Base Modernization Agency
ATTN: SARPM-PBM-L
SARPM-PBM-T-PA
Dover, NJ 07801

Commander
U.S. Army Armament Materiel
Readiness Command
ATTN: DRSAR-MAD-C, P. Shaw
Dover, NJ 07801

Commander
U.S. Army Armament Materiel
Readiness Command
ATTN: DRSAR-Q
DRSAR-LEP-L
Rock Island, IL 61299

Administrator
Defense Technical Information Center
ATTN: Accessions Division (12)
Cameron Station
Alexandria, VA 22314

Director
U.S. Army Materiel Systems
Analysis Activity
ATTN: DRXSY-MP
Aberdeen Proving Ground, MD 21005

PRECEDING PAGE BLANK-NOT FILMED

Commander/Director
Chemical Systems Laboratory
U.S. Army Armament Research
and Development Command
ATTN: DRDAR-CLJ-L
DRDAR-CLB-PA
APG, Edgewood Area, MD 21010

Director
Ballistics Research Laboratory
U.S. Army Armament Research
and Development Command
ATTN: DRDAR-TSB-S
Aberdeen Proving Ground, MD 21005

Chief
Benet Weapons Laboratory, LCWSL
U.S. Army Armament Research
and Development Command
ATTN: DRDAR-LCB-TL
Watervliet, NY 12189

Director
U.S. Army TRADOC Systems
Analysis Activity
ATTN: ATAA-SL
White Sands Missile Range, NM 88002