

AD A107935

TECHNICAL
MEMORANDUM
NCSC TM 323-81

OCTOBER 1981

**IMPEDANCE MATCHING FOR
LONG CABLES CARRYING
ULTRASONIC SIGNALS**

JOHN MITTLEMAN

**DTIC
ELECTE
DEC 1 1981
B**

This document has been approved for
public release and sale; its distribution
is unlimited.

USE COPY



NAVAL COASTAL SYSTEMS CENTER

NCSC

PENSACOLA CITY, FLORIDA

32407



COPY 212

81 11 17 017

REPORT DOCUMENTATION PAGE		READ INSTRUCTIONS BEFORE COMPLETING FORM
1. REPORT NUMBER TM 325-81	2. GOVT ACCESSION NO. 4D A107 935	3. RECIPIENT'S CATALOG NUMBER
4. TITLE (and Subtitle) Impedance Matching for Long Cables Carrying Ultrasonic Signals		5. TYPE OF REPORT & PERIOD COVERED
		6. PERFORMING ORG. REPORT NUMBER
7. AUTHOR(s) John Mittleman		8. CONTRACT OR GRANT NUMBER(s)
9. PERFORMING ORGANIZATION NAME AND ADDRESS Naval Coastal Systems Center Panama City, FL 32407		10. PROGRAM ELEMENT, PROJECT, TASK AREA & WORK UNIT NUMBERS Task WR02574
11. CONTROLLING OFFICE NAME AND ADDRESS		12. REPORT DATE October 1981
		13. NUMBER OF PAGES 25
14. MONITORING AGENCY NAME & ADDRESS (if different from Controlling Office)		15. SECURITY CLASS. (of this report) UNCLASSIFIED
		15a. DECLASSIFICATION DOWNGRADING SCHEDULE N/A
16. DISTRIBUTION STATEMENT (of this Report) This document has been approved for public release and sale; its distribution is unlimited.		
17. DISTRIBUTION STATEMENT (of the abstract entered in Block 20, if different from Report)		
18. SUPPLEMENTARY NOTES		
19. KEY WORDS (Continue on reverse side if necessary and identify by block number) Cables; Impedance Matching; Ultrasonics; Transducers; Testing; Transmission Lines; Signals		
20. ABSTRACT (Continue on reverse side if necessary and identify by block number) Long coaxial cables, when used for ultrasonic inspection, have been known to produce extraneous signals and attenuate valid signals. In this report, the theory of transmission lines is applied to such cables and is shown to predict the unwanted phenomena. The theory is then applied to the design of matching networks composed of one resistive and one inductive component. A series R-L network placed in parallel with the transducer is shown to produce a satisfactory impedance match, and its performance is demonstrated through		

UNCLASSIFIED

SECURITY CLASSIFICATION OF THIS PAGE (When Data Entered)

20. ABSTRACT (continued):

experiments on a 1000-foot length of coaxial cable terminated by the network and an ultrasonic transducer.

S/N 0102-LF-014-6601

UNCLASSIFIED

SECURITY CLASSIFICATION OF THIS PAGE (When Data Entered)

LIST OF SYMBOLS

A	Attenuation constant for a known cable length (dB)
B	Phase constant for a known cable length (degrees)
C	Capacitance (Farads)
E	Voltage (volts)
E_L	Voltage at the load (receiving) end
E_s	Voltage at the generator (sending) end
F	Frequency (Megahertz)
I	Current (Amperes)
I_L	Current at the load end
I_s	Current at the sending end
L	Inductance (Henries)
R	Resistance (ohms)
Z	Impedance (complex), (ohms)
Z_o	Characteristic impedance
Z_g	Source (generator) output impedance
Z_L	Load input impedance
Z_s	Cable input impedance at the sending end
Z_s (short)	Z_s with the load end short circuited
Z_s (open)	Z_s with the load end open circuited
Z_{sc}	Z_s (short)
c	Speed of light in a vacuum ($\approx 3 \times 10^8 \frac{m}{sec}$)
e	Base of natural logarithms (2.718. . .)
j	$\sqrt{-1}$
l	Cable length (feet or metres)

NCSC TM 325-81

v	Speed of electromagnetic wave propagation in a material
α	Attenuation constant ($\frac{\text{dB}}{1000 \text{ feet}}$ or $\frac{\text{nepers}}{\text{metre}}$)
β	Phase constant ($\frac{\text{degrees}}{1000 \text{ feet}}$ or $\frac{\text{radians}}{\text{metre}}$)
γ	Propagation constant ($\alpha + j\beta$)
π	Pi (3.141. . .)
τ	Time (seconds)
ω	Angular frequency ($\frac{\text{radians}}{\text{second}}$)

TABLE OF CONTENTS

	<u>Page No.</u>
BACKGROUND	1
BASIC EQUATIONS	1
CABLE PARAMETERS	3
LOAD PARAMETERS	11
IMPLEMENTATION	17
CONCLUSIONS	21
RECOMMENDATIONS	23

Accession For	
NTIS GRA&I	<input checked="" type="checkbox"/>
DTIC TAB	<input type="checkbox"/>
Unannounced	<input type="checkbox"/>
Justification	
By	
Distribution/	
Availability Codes	
Avail and/or	
Dist	Special
A	

LIST OF ILLUSTRATIONS

<u>Figure No.</u>		<u>Page No.</u>
1	Instrumentation for Cable Parameter Measurements	6
2	Cable Impedance (Magnitude)	7
3	Characteristic Impedance	8
4	Attenuation Coefficient	9
5	Phase Constant	10
6	Impedance Comparison of Cable and Transducer	12
7	Transducer Impedance (Magnitude)	13
8	Matched Transducer Impedance	15
9	Cable and Series Matched Transducer Impedance	16
10	Cable and Parallel Matched Transducer Impedance	18
11	Impedance of Wire Coils	19
12	Network Construction	20
13	Waveform Comparisons	22

BACKGROUND

Underwater ultrasonic testing at the Naval Coastal Systems Center (NCSC) is performed by a team composed of a diver and a topside technician. Sufficient transducer cable is used so that all test hardware remains out of water, except the transducer.

Unfortunately, the long transducer cable acts as an electrical network for which neither the ultrasonic pulser/receiver nor the transducer was designed, so the quality of ultrasonic signals is often degraded. At first, it was thought that amplification of the signals generated by the transducer would restore the signal quality; but it was later realized that the fundamental problem is created by impedance mismatches which foster reflections and decrease power transmitted to and from the transducer.

During 1980 efforts to increase the usable transducer cable length centered around impedance matching network design.

BASIC EQUATIONS

In our impedance matching design work, the following basic equations which relate electrical conditions at the ends of a transmission cable were used:¹

$$E_s = (E_L + I_L Z_o) (e^{\gamma \ell})/2 + (E_L - I_L Z_o) (e^{-\gamma \ell})/2$$

and
$$I_s = (E_L + I_L Z_o) (e^{\gamma \ell})/2Z_o - (E_L - I_L Z_o) (e^{-\gamma \ell})/2Z_o$$

where E_s and I_s are voltage and current at the sending end

E_L and I_L are voltage and current at the receiving end

¹Karakash, John J., "Transmission Lines and Filter Networks," MacMillan Co., 1950.

Z_0 is the cable's characteristic impedance

γ is a propagation constant and

ℓ is the cable length

Note that for an infinitely long cable (in which there is no reflected wave) the term $e^{-\gamma\ell}$ drops out and the sending end impedance is the characteristic impedance, Z_0 .

$$Z_s \text{ (for } \ell = \infty) = \frac{E_s}{I_s} \text{ (for } \ell = \infty) = Z_0$$

Also note that the equations are reminiscent of hyperbolic functions; in fact, for the load end open circuited or short circuited the input impedances are

$$Z_s \text{ (open circuit at load end)} = Z_0 \coth \gamma\ell$$

or $Z_s \text{ (short circuit at load end)} = Z_0 \tanh \gamma\ell$

For any other load impedance the input impedance can be expressed as

$$Z_s \text{ (for } Z_L \text{ at load end)} = Z_s \text{ (open)} \frac{(Z_s \text{ (short)} + Z_L)}{(Z_s \text{ (open)} + Z_L)}$$

Looking from the load end toward the pulser/receiver (which has an internal impedance of Z_g) the equations can be written in much the same fashion. This leads to the following configuration:

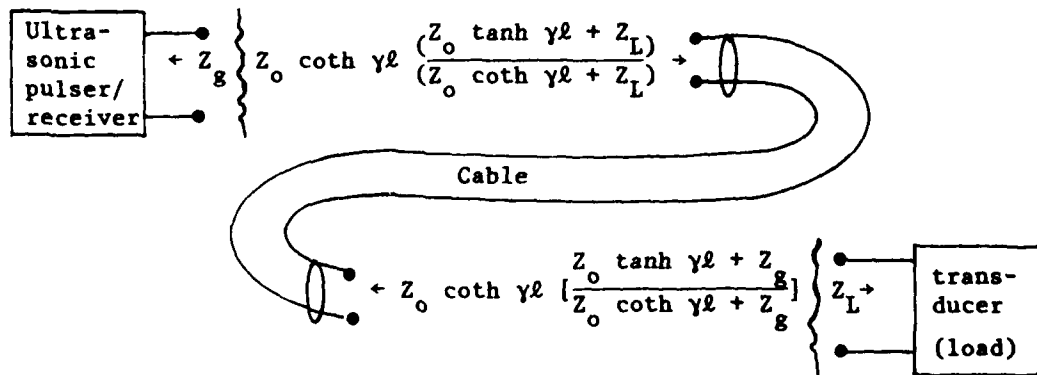

The possibilities for mismatched impedances are numerous. Inefficient power transfers and troublesome reflections can occur at both cable ends unless impedances are properly matched. This is not easy since the load impedance (the transducer's impedance) varies as a function of frequency. The term "matching" is somewhat deceiving in that it does not mean equating the impedances looking up and down the cable from any given point. Rather, it means making the impedance looking either direction from any point on the cable equal to the cable's characteristic impedance. Though this is a more restrictive requirement than having equal impedances looking in both directions, it is not as bad as first thought because if both ends are terminated in a device having an input impedance equal to the characteristic impedance ($Z_g = Z_L = Z_o$) then the input impedance of the terminated cable becomes:

$$Z_s = Z_o \coth \gamma \ell \left[\frac{Z_o \tanh \gamma \ell + Z_o}{Z_o \coth \gamma \ell + Z_o} \right] = Z_o$$

showing that cable length and the propagation constant drop out of the expression.

To predict performance if Z_L or Z_g is not equal to Z_o the variables seen in the preceding expressions; namely, Z_o , $\gamma \ell$, Z_g , and Z_L must be quantified. The following discussions pertain to this quantification.

CABLE PARAMETERS

Cable parameters are, at best, difficult to measure, and manufacturer's information is often available at only a few selected frequencies. However, with modern electronic impedance measuring instruments the task is tractable.

Let us consider what measurements would be of use. Knowing that $Z_{sc} = Z_o \tanh \gamma \ell$ (where Z_{sc} indicates the cable's input impedance with the load end short circuited) allows calculation of the magnitude (or phase) of the cable's input impedance when the cable is short circuited if Z_o (the characteristic impedance), γ (the propagation constant), and ℓ (the cable length) are known. Alternatively, measurements can be taken and calculations made to determine the unknown constants. For instance, if the magnitude of Z_{sc} (denoted $||Z_{sc}||$) and the angle of Z_{sc} (denoted $\angle Z_{sc}$) are measured then $\gamma \ell$ and Z_o can be determined as follows:

$$Z_{sc} = Z_o \tanh \gamma l$$

$$\|Z_{sc}\| = \|Z_o\| \|\tanh \gamma l\|$$

and $\underline{x} Z_{sc} = \underline{x} Z_o + \underline{x} \tanh \gamma l$

Since γl may be complex, let us substitute $A + jB$ for γl .

Then $\|Z_{sc}\| = \|Z_o\| \|\tanh (A + jB)\|$

By straightforward algebraic manipulation we find

$$\tanh (A+jB) = \frac{e^{A+jB} - e^{-(A+jB)}}{e^{A+jB} + e^{-(A+jB)}}$$

reduces to

$$\tanh (A+jB) = \frac{e^{2A} - e^{-2A} + 2j \sin 2B}{e^{2A} + e^{-2A} + 2 \cos 2B}$$

from which

$$\|\tanh (A+jB)\| = \frac{(e^{4A} + e^{-4A} - 2 \cos 4B)^{\frac{1}{2}}}{(e^{2A} + e^{-2A} + 2 \cos 2B)}$$

Note that $A = \alpha l$ (the attenuation constant) and $B = \beta l$ (the phase constant) can be expected to be smoothly increasing functions of frequency. Thus, periodicity in $\|\tanh \gamma l\|$, (or, since $\|Z_o\|$ is also expected to be a slowly varying function of frequency, periodicity in $\|Z_{sc}\|$) is attributable

to the periodic nature of $\cos 2B$ and $\cos 4B$, and will produce local extrema when $2B$ is approximately equal to a multiple of π (180°). When this is the case,

$$\|Z_{sc}\| \approx \|Z_o\| \left(\frac{e^{4A} + e^{-4A} \mp 2}{e^{2A} + e^{-2A} \pm 2} \right)^{\frac{1}{2}}$$

which reduces to

$$\|Z_{sc}\| = \|Z_o\| \tanh A \text{ (at local minima)}$$

or

$$\|Z_{sc}\| = \|Z_o\| \coth A \text{ (at local maxima)}$$

With these two equations in hand we are ready to use measurements of $\|Z_{sc}\|$ since we now know that (at least approximately)

- The upper envelope of $\|Z_{sc}\|$ is $\|Z_o\| \coth A$.
- The lower envelope of $\|Z_{sc}\|$ is $\|Z_o\| \tanh A$.
- Local maxima of $\|Z_{sc}\|$ occur at B equal to odd multiples of $\pi/2$.
- Local minima of $\|Z_{sc}\|$ occur at B equal to even multiples of $\pi/2$.

For A, B, and Z_o varying smoothly as functions of frequency, interpolation between extrema can be used to find

$$\|Z_o\| = \left(\frac{\|Z_{sc}\|_{\text{upper envelope}}}{\|Z_{sc}\|_{\text{lower envelope}}} \right)^{\frac{1}{2}}$$

$$\text{and } \tanh A = \left(\frac{\|Z_{sc}\|_{\text{upper envelope}}}{\|Z_{sc}\|_{\text{lower envelope}}} \right)^{\frac{1}{2}}$$

from which A can be calculated

$$A = \frac{1}{2} \ln \left(\frac{1 + \tanh A}{1 - \tanh A} \right)$$

The extrema themselves are used to plot B as a function of frequency since extrema occur at $B \approx n\pi/2$.

This procedure was applied to measurements taken on 1000 feet of RG-58 coaxial cable. Impedance measurements were made every 0.02 MHz from 0.5 MHz to 6.48 MHz using the instrumentation shown schematically in Figure 1. These impedance values (Figure 2) were the basis for calculations leading to values of $\|Z_o\|$, A, and B shown in Figures 3, 4, and 5. Curve fitting yielded the following expressions which, while approximate, serve well for calculations:

$$Z_o \approx 50\Omega$$

$$A \approx (4.8 \sqrt{F} - 1.4) \text{ dB}$$

$$B \approx 564F \text{ degrees}$$

where F is frequency, in megahertz.

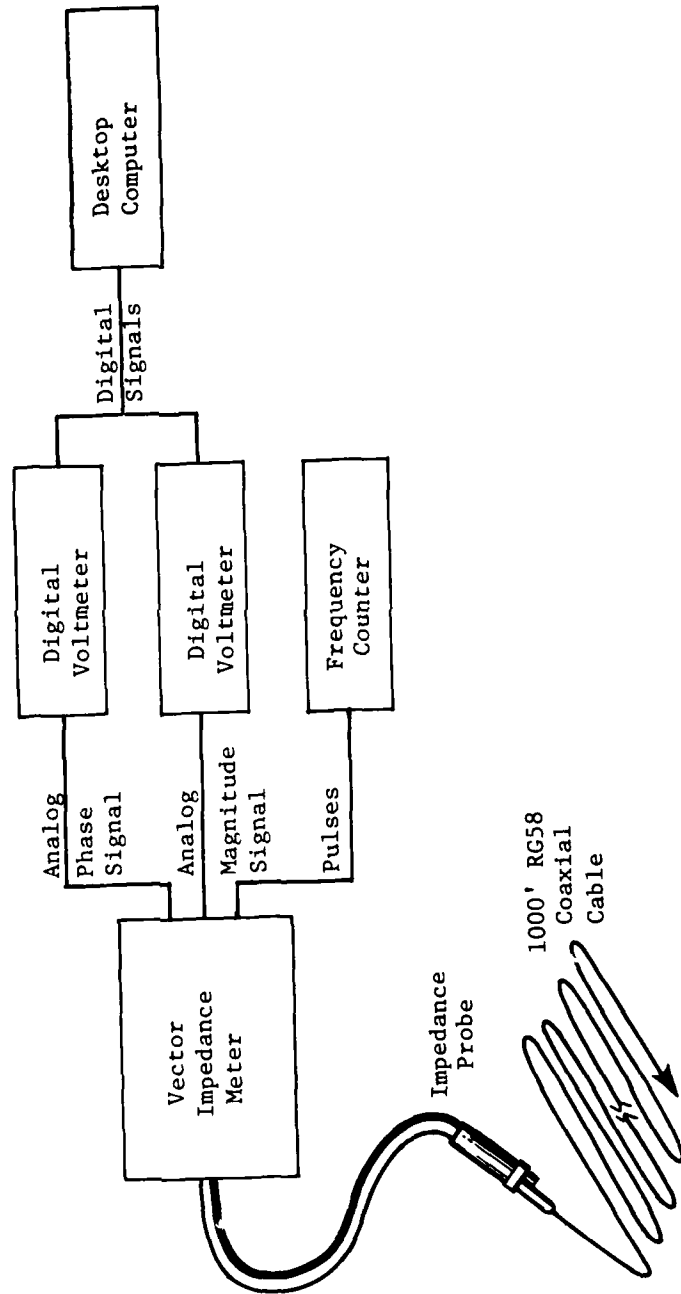

FIGURE 1. INSTRUMENTATION FOR CABLE PARAMETER MEASUREMENTS

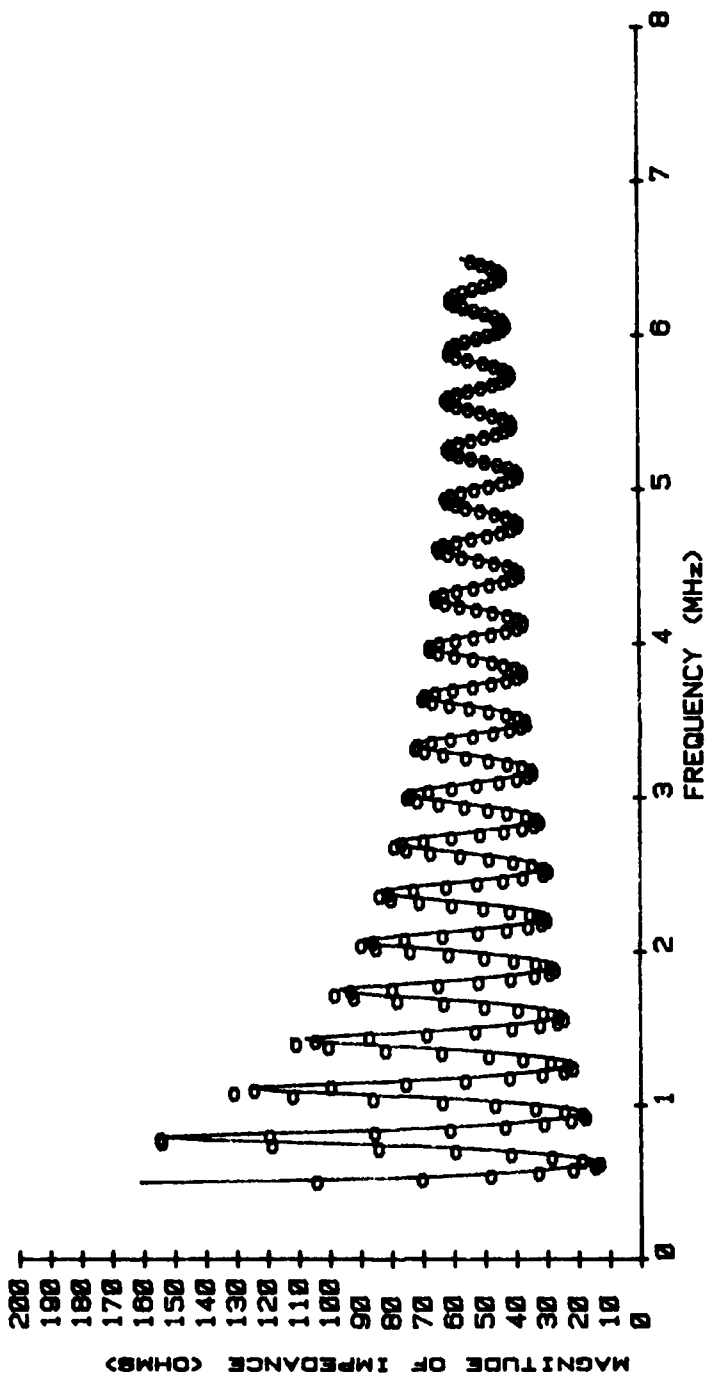

FIGURE 2. CABLE IMPEDANCE (MAGNITUDE)

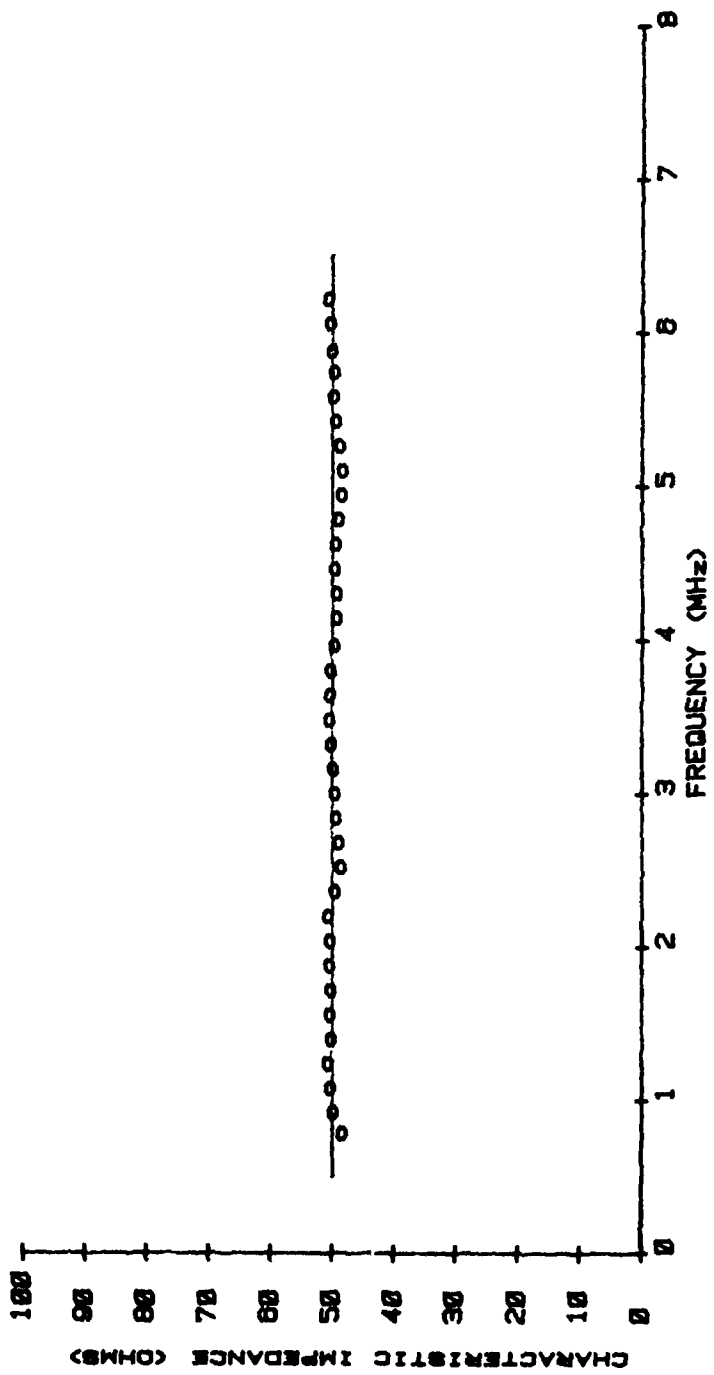

FIGURE 3. CHARACTERISTIC IMPEDANCE

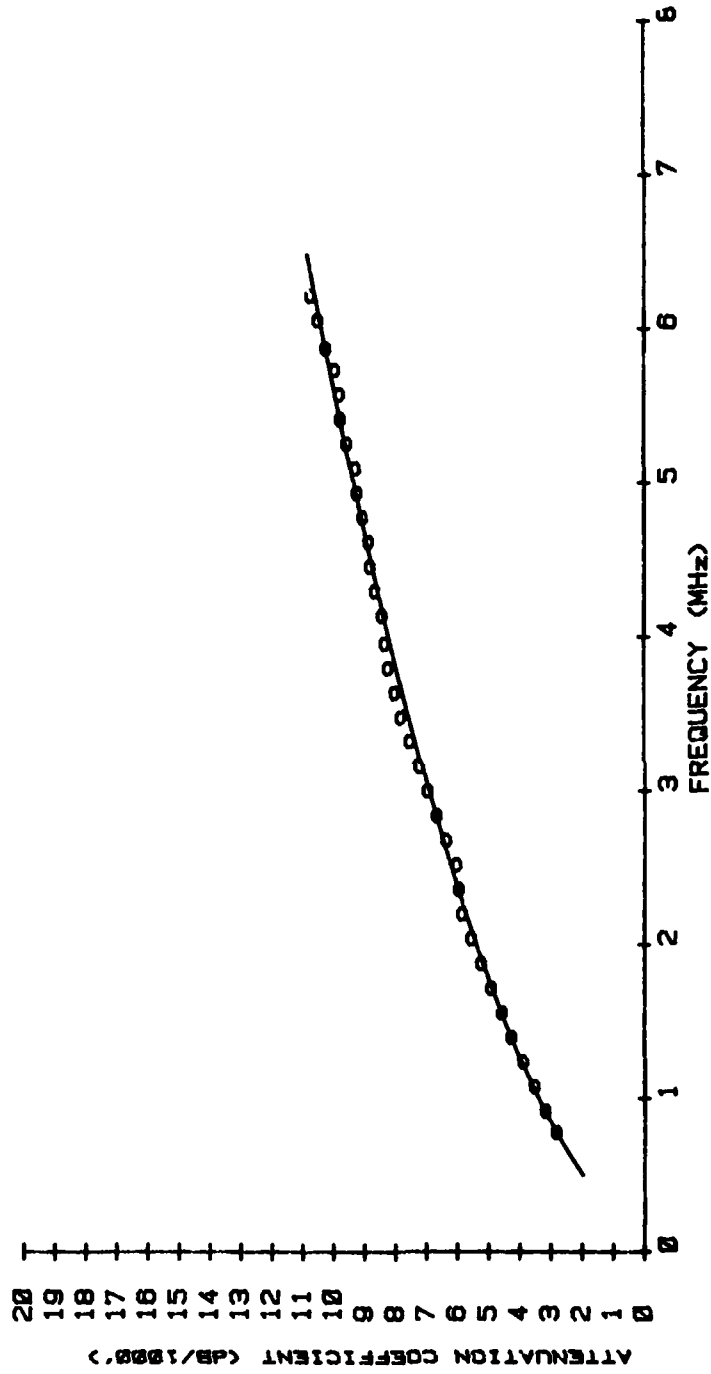

FIGURE 4. ATTENUATION COEFFICIENT

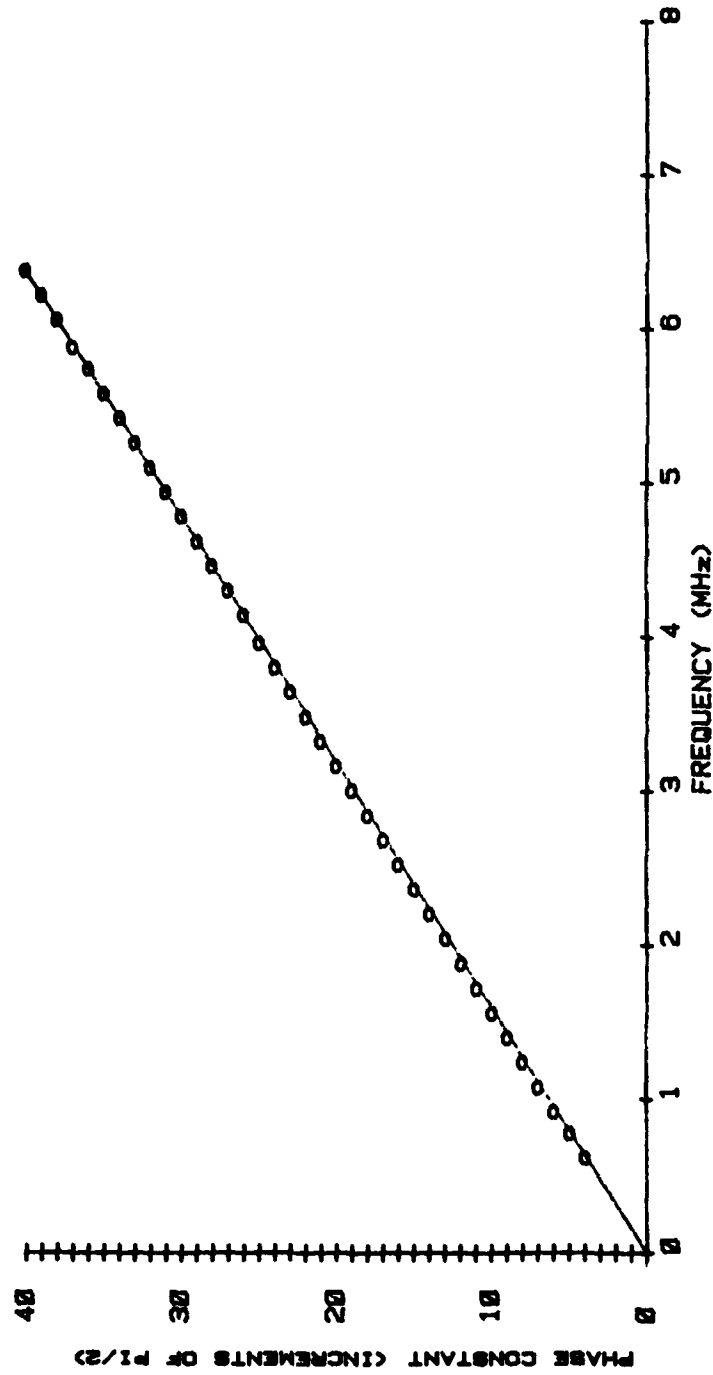

FIGURE 5. PHASE CONSTANT

And finally, the characteristic impedance Z_0 has a small imaginary (reactive) component, but it is typically ignored. Measurements of $\angle Z_{sc}$ were taken, and from these $\angle Z_0$ was found to be only a few degrees.

LOAD PARAMETERS

The ultrasonic transducer (the load) is primarily a capacitive device. Off-the-shelf pulser/receivers (ultrasonic instruments) are typically designed to excite this sort of load quite effectively. However, when the transducer is at the end of a long cable, instead of looking into an impedance of $1/j\omega C$ (a capacitor) the pulser/receiver looks into an impedance of

$$Z_0 \coth \gamma \ell \left[\frac{Z_0 \tanh \gamma \ell + \frac{1}{j\omega C}}{Z_0 \coth \gamma \ell + \frac{1}{j\omega C}} \right]$$

Figure 6 shows the capacitive characteristics of a transducer swamped by the presence of a long cable, and clearly indicates that remedial action is required. First, it would be desirable to terminate the cable in such a way as to prevent reflections from occurring since they show up at the receiver amplifier of the ultrasonic instrument and create problems. The following example shows one method of matching and its effect on input impedance.

First, the transducer's input impedance is measured and modeled (Figure 7). In this case, a 1/2-inch unfocused transducer with a 2.25 MHz center frequency is modeled well by a 1.0 nanofarad capacitor. Then, to make the load impedance 50 ohms (pure real) at 2.25 MHz, a series resistor-inductor combination is placed in parallel with it.

The objective is to make the network's input impedance, Z , equal to Z_0 at 2.25 MHz. Using the model shown below the input impedance and appropriate values of components are calculated:

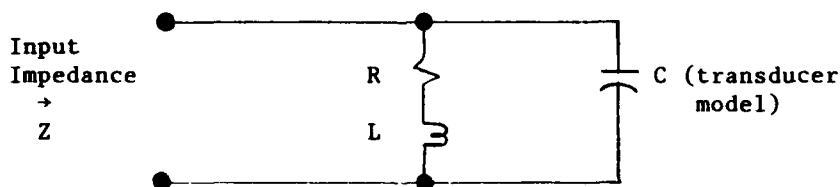

$$Z = [(R + j\omega L)(1/j\omega C)]/[R + j\omega L + (1/j\omega C)]$$

$$Z = (R + j\omega L)/[j\omega RC + (1 - \omega^2 LC)]$$

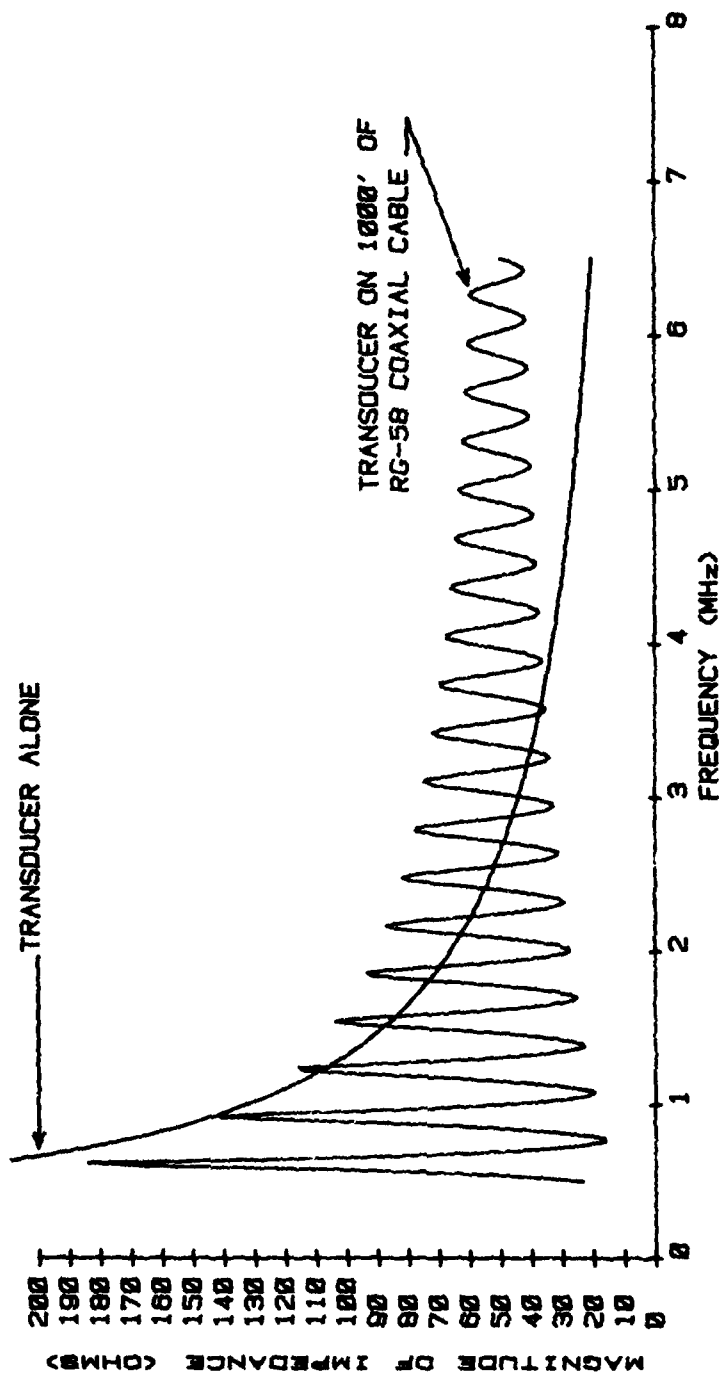

FIGURE 6. IMPEDANCE COMPARISON OF CABLE AND TRANSUDUCER

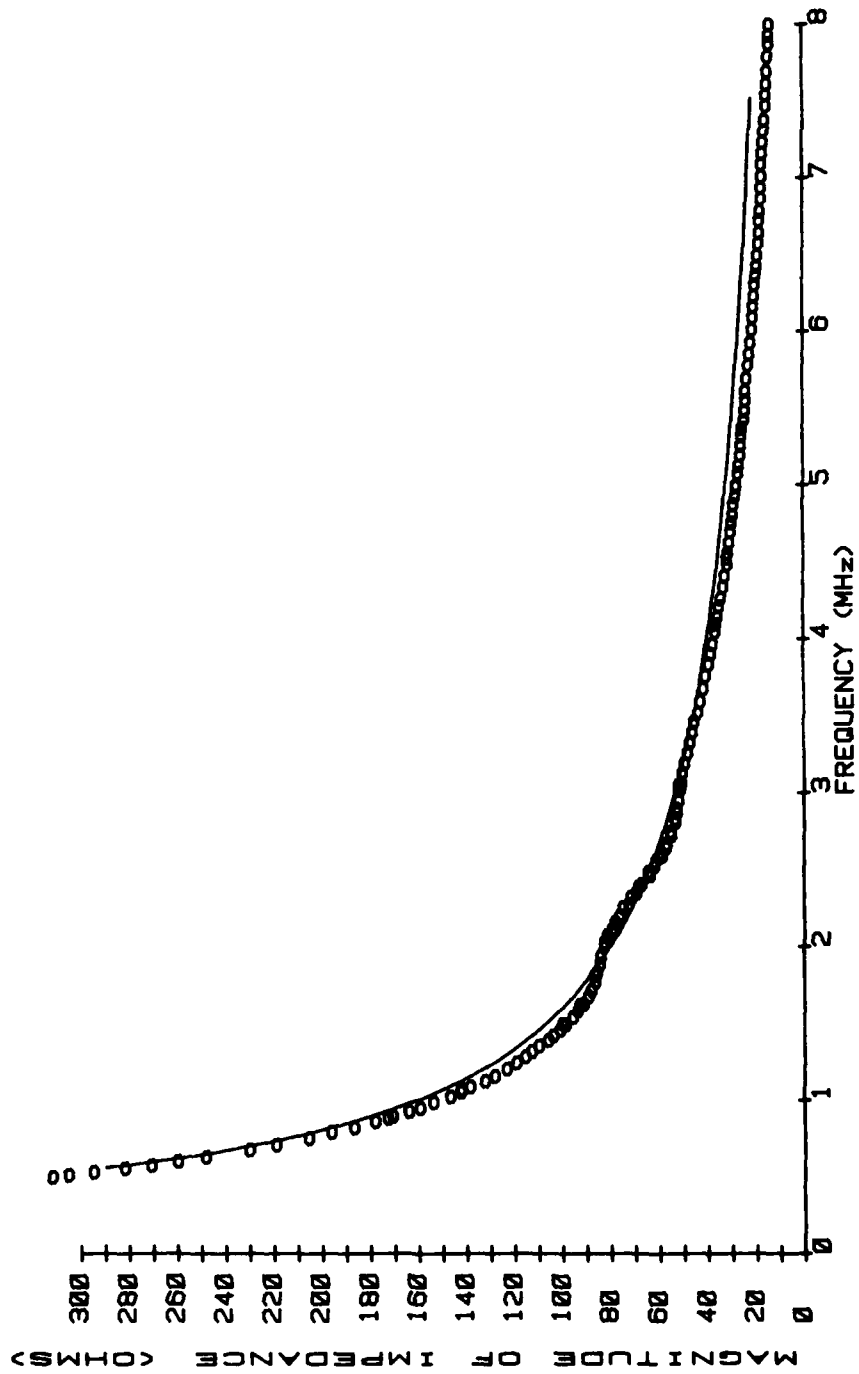

FIGURE 7. TRANSDUCER IMPEDANCE (MAGNITUDE)

Separating this into a real and imaginary part gives

$$Z = \frac{R}{(1-\omega^2 LC)^2 + (\omega RC)^2} + j\omega C \frac{\frac{L}{C} (1 - \omega^2 LC) - R^2}{(1-\omega^2 LC)^2 + (\omega RC)^2}$$

For Z to equal $Z_0 + j0$ (a pure real value),

$$0 = \frac{L}{C} (1 - \omega^2 LC) - R^2$$

from which $R = \left[\frac{L}{C} (1 - \omega^2 LC) \right]^{\frac{1}{2}}$

Also, $Z = \frac{R}{(1-\omega^2 LC)^2 + (\omega RC)^2}$ must be made to equal Z_0 .

Substituting the expression for R and solving gives

$$L = Z_0^2 C / (1 + Z_0^2 \omega^2 C^2)$$

and $R = Z_0 / (1 + Z_0^2 \omega^2 C^2)$

In the case we have chosen, where

$$Z_0 = 50\Omega$$

$$C = 1.0 \times 10^{-9} \text{ Farad}$$

$$\omega = 2\pi \times 2.25 \times 10^6 \text{ Hz}$$

we find $L = 1.667 \times 10^{-6} \text{ Henry}$

$$R = 33.34\Omega$$

The impedance of this network as a function of frequency is shown in Figure 8, and its effect on the cable's input impedance is shown in Figure 9. Comparison of Figure 9 with the unmatched case (Figure 6) shows that a substantial improvement has been made.

The series R-L network in parallel with the transducer is not the only available configuration. In fact, limiting the choice to one resistor and one inductor allows three additional configurations:

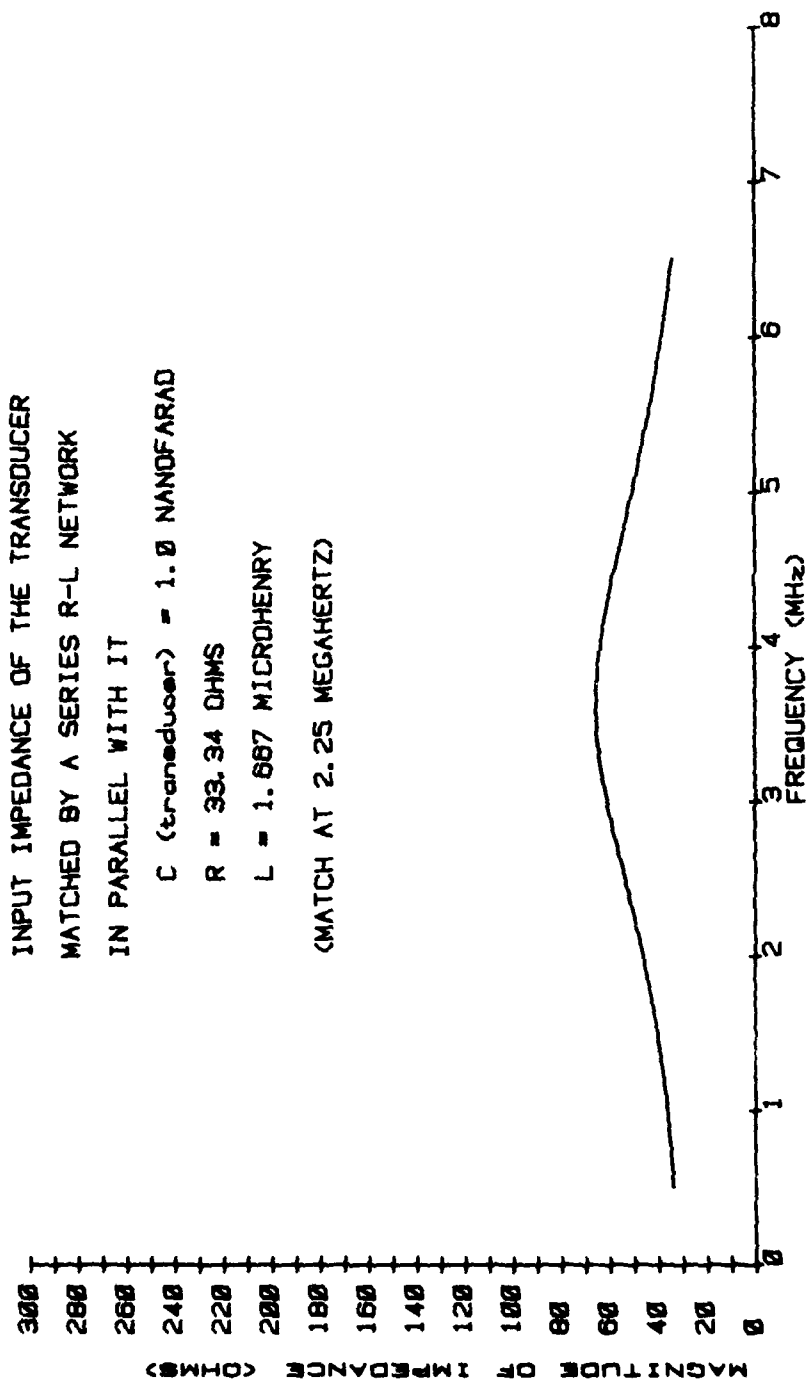

FIGURE 8. MATCHED TRANSDUCER IMPEDANCE

INPUT IMPEDANCE OF 1000 FEET OF
RG-58 COAXIAL CABLE TERMINATED BY
A SERIES R-L NETWORK IN PARALLEL
WITH THE TRANSDUCER.

$$R = 33.34 \text{ OHMS}$$

$$L = 1.667 \text{ MICROHENRY}$$

$$C(\text{transducer}) = 1.0 \text{ NANOFARAD}$$

(IMPEDANCE MATCH AT 2.25 MHz)

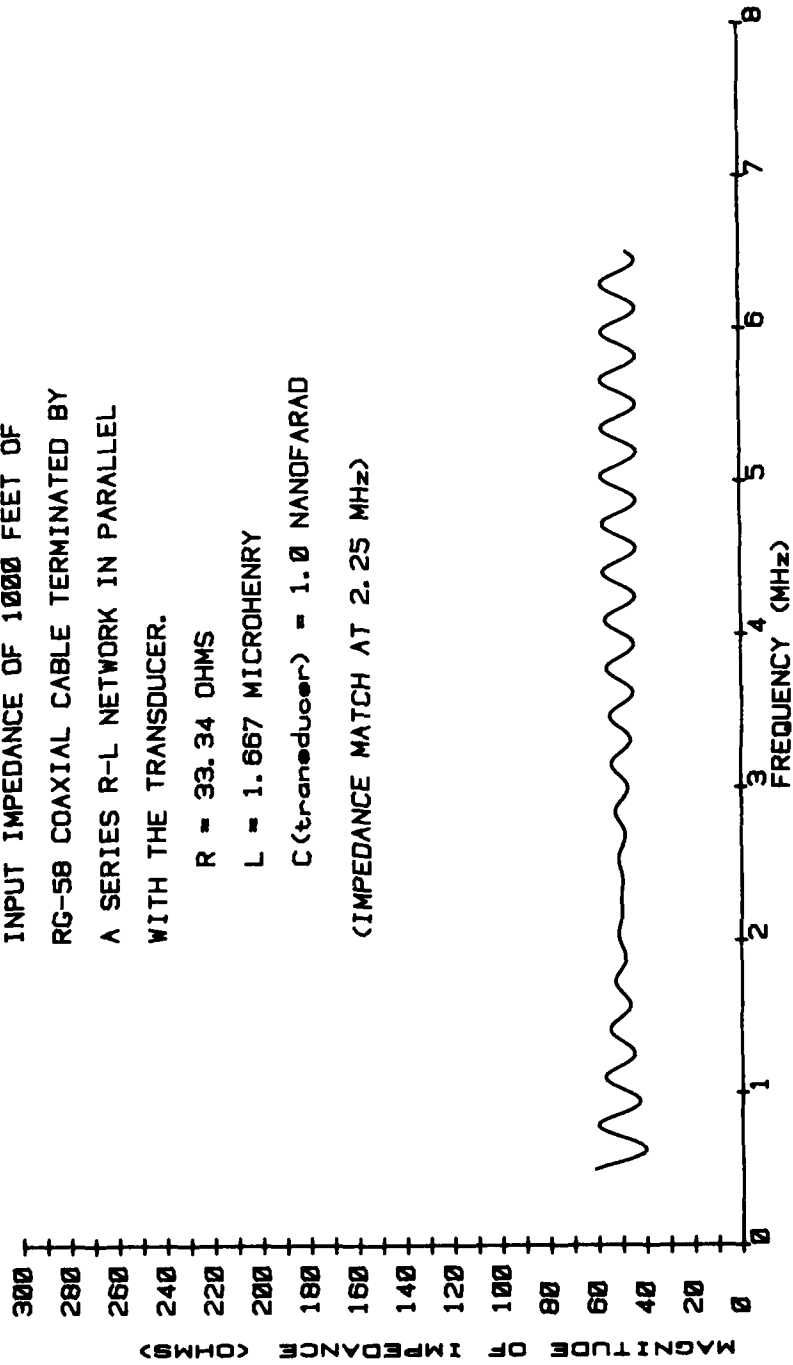
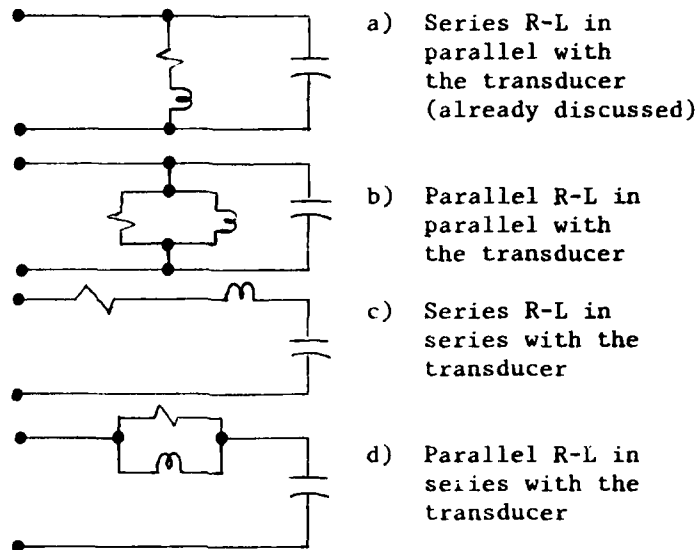

FIGURE 9. CABLE AND SERIES MATCHED TRANSDUCER IMPEDANCE



Options (c) and (d) have the unfortunate characteristic of reducing the voltage applied to the transducer and are therefore eliminated from consideration. Option (b) was studied since it allows full voltage to be applied to the transducer. Shown in Figure 10 are measured data and the theoretical curve for this configuration. This figure shows that at frequencies below 2.25 MHz the performance of this configuration is not as good as the series R-L network in parallel with the transducer (option (a)).

Other configurations which might perhaps utilize a wide-band transformer in the matching network have not been studied.

IMPLEMENTATION

Having found that a series R-L network in parallel with the transducer improves the transmission of pulses to the transducer, the next objective was to implement this network in hardware. Several approaches are possible, and one of these is described below. Since mechanical strength, small size, and waterproofed construction are desirable qualities it was decided to wind the inductor around the coaxial cable and pot the entire network in the standard NCSC cable termination which mates with the standard NCSC transducer housing. With no particular attempt to optimize the construction (by choosing a very fine wire size whose resistance and inductance would be correct without an additional resistor) a number 31 magnet wire was investigated and found to give approximately 1 microhenry per 20 turns around the coaxial cable (Figure 11). Thus, 33 turns in series with a 33 ohm resistor would form a suitable network. The steps used in building this are shown in Figure 12.

COMPARISON OF THEORETICAL AND MEASURED
 IMPEDANCE VALUES FOR 1000 FEET OF RG-58
 COAXIAL CABLE TERMINATED BY AN ULTRASONIC
 TRANSDUCER AND A PARALLEL R-L NETWORK TO
 MATCH THE TRANSDUCER'S CAPACITANCE AT
 2.25 MHz

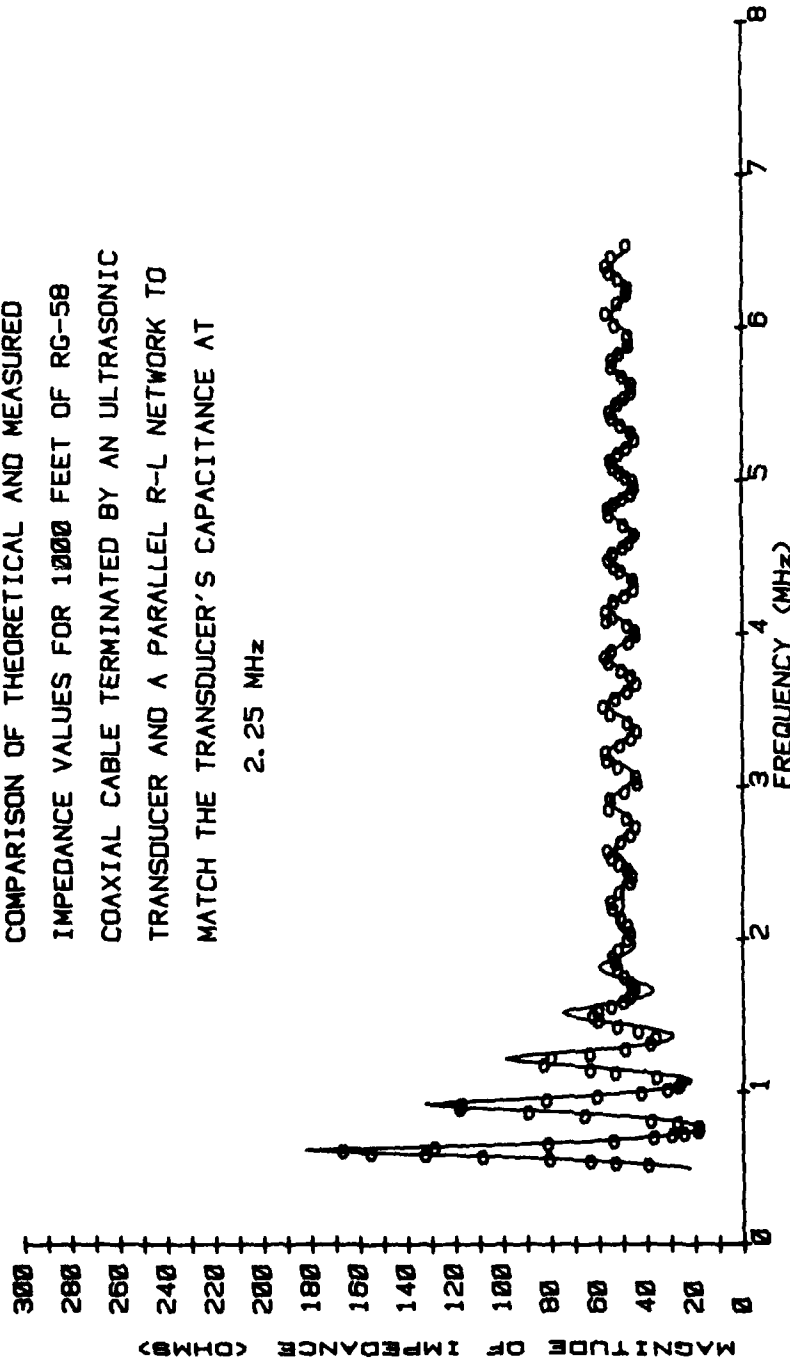

FIGURE 10. CABLE AND PARALLEL MATCHED TRANSDUCER IMPEDANCE

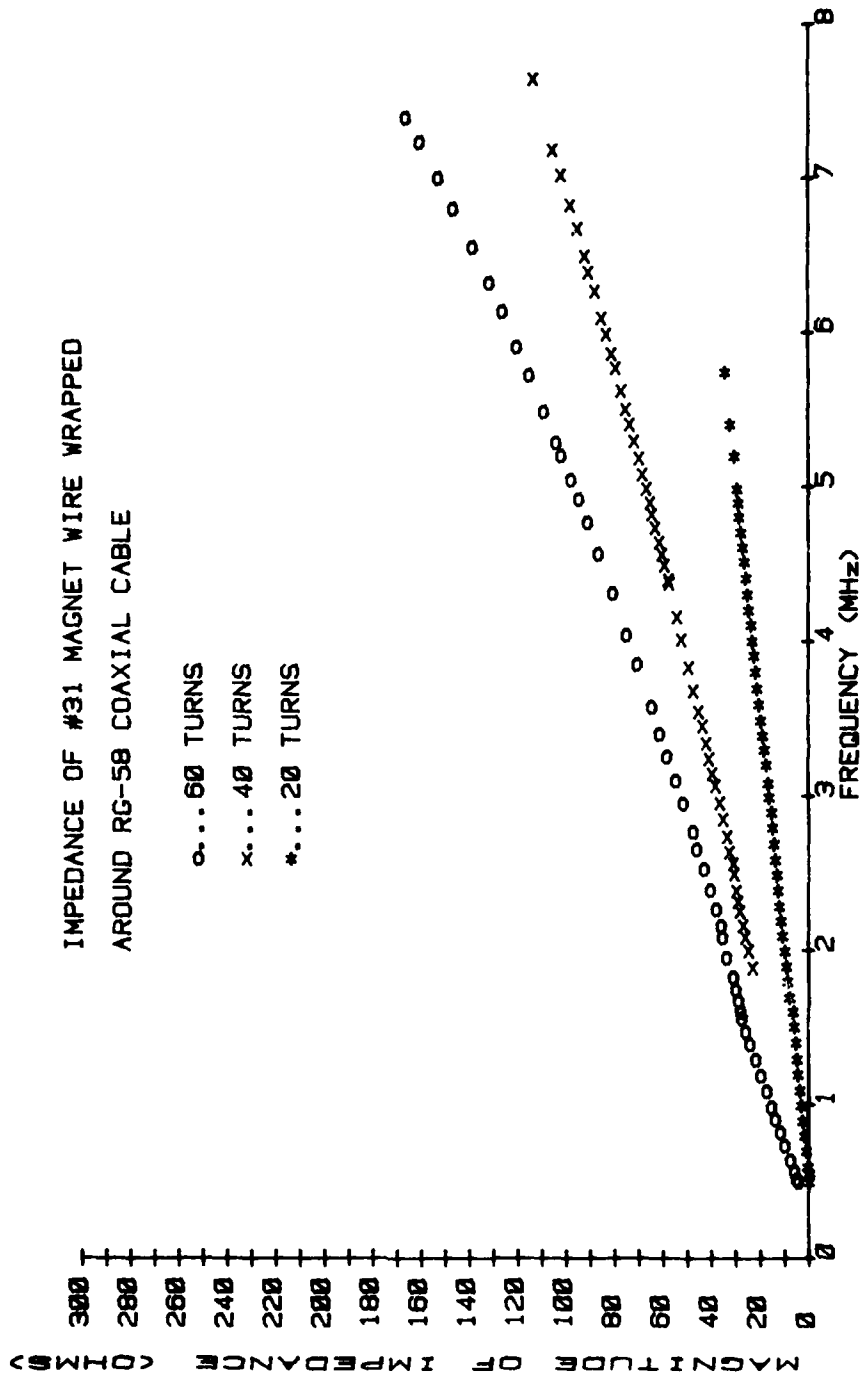

FIGURE 11. IMPEDANCE OF WIRE COILS

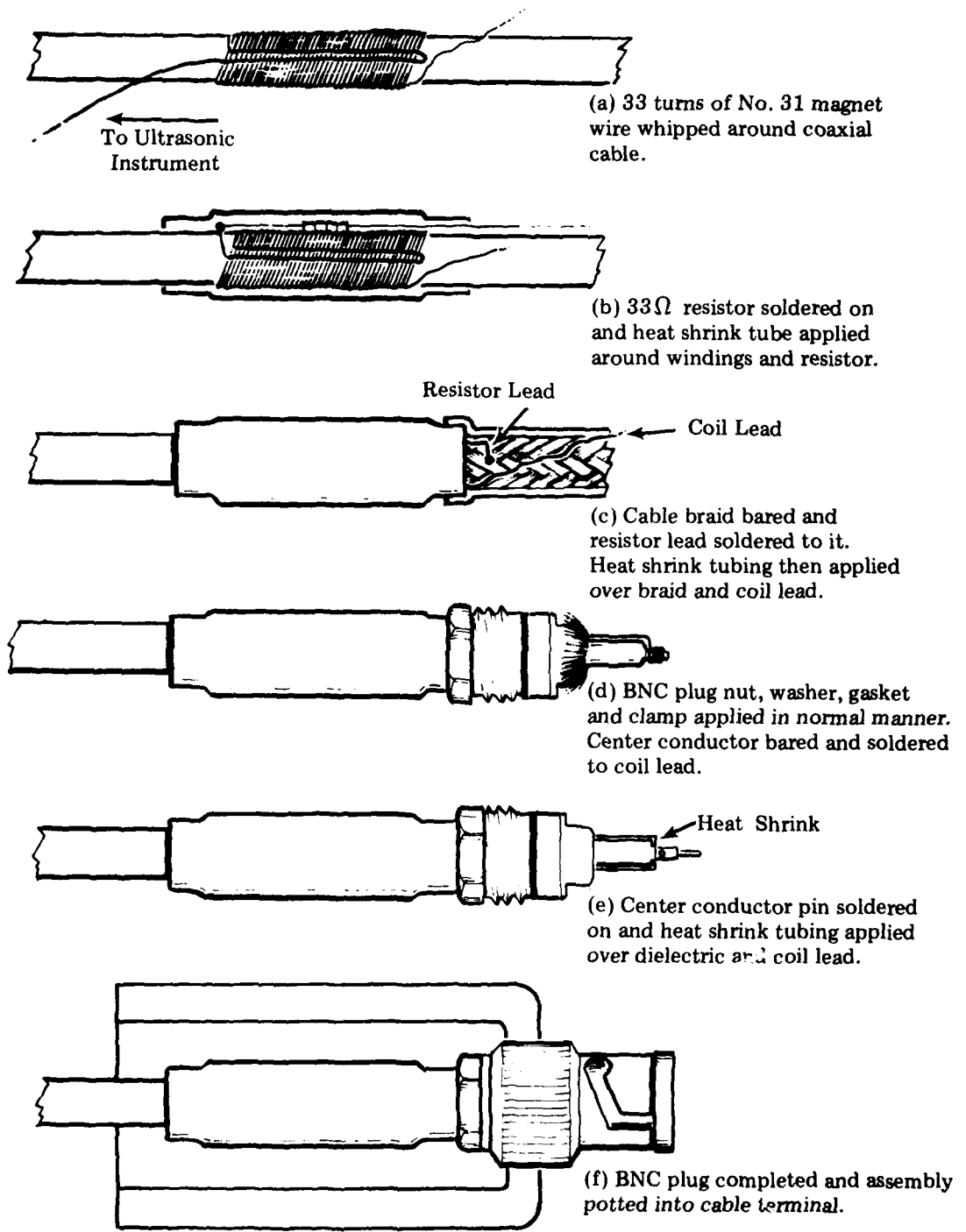

FIGURE 12. NETWORK CONSTRUCTION

The results of this construction applied to a 740-foot length of C-N-4 coaxial cable are shown in Figures 13a through 13d. It should be noted that C-N-4, like RG-58, has a characteristic impedance of 50Ω . C-N-4 differs from RG-58 primarily in its jacket which is an abrasion resistant non-hosing (water blocking) neoprene rather than plastic material. Electrically, the two cables are quite similar. Figures 13a and 13c show conditions at the pulser and the transducer, respectively, for the cable before the matching network was connected. Evident in Figure 13a are a series of initial pulses rather than a single spike. The spacing between pulses indicates that 2.26 microseconds separate them. We calculate the time it would take an electromagnetic wavefront to travel 1480 feet of cable (round trip in a 740-foot length) as follows:

$$\tau = \frac{2\ell}{v} \approx \frac{2\ell}{\left(\frac{2}{3}c\right)}$$

since the electromagnetic wave's propagation velocity in a cable filled with the dielectric used is about two-thirds the speed of light in a vacuum.

$$\tau \approx \frac{2 \times 740 \text{ feet}}{0.67 \times 3 \times 10^8 \frac{\text{m}}{\text{sec}}} \times \frac{\text{metre}}{3.28 \text{ feet}} = 2.25 \text{ microseconds}$$

This agreement with the time interval read off the oscilloscope screen helps confirm that reflections can and do occur. Their detrimental effect on the received waveform is shown in Figure 13b in which both the received waveform (upper) and the video presentation (lower) are shown. The first three spikes, from left to right on the video portion are the front surface echo, a spurious spike resulting from the reflection, and the first backwall echo from a 0.75-inch thick aluminum specimen. An ultrasonic inspector using this unmatched cable would have no way of determining the false indication from an internal defect or a thin area. Figures 13c and 13d show what occurs when the matching network is connected. First, the initial pulse is considerably cleaner and second, since the transducer is excited only once, the false indication disappears from the video presentation.

CONCLUSIONS

With suitable matching networks "off-the-shelf" NDT ultrasonic testing instrumentation can be operated with long (1000-foot) pulse generator-to-transducer cabling. This permits the instrumentation to be located topside where a UT technician can analyze the data in relative comfort. Also, with computer assistance the UT technician can analyze large amounts of data, edit it, and have it in report format shortly after the test is completed.

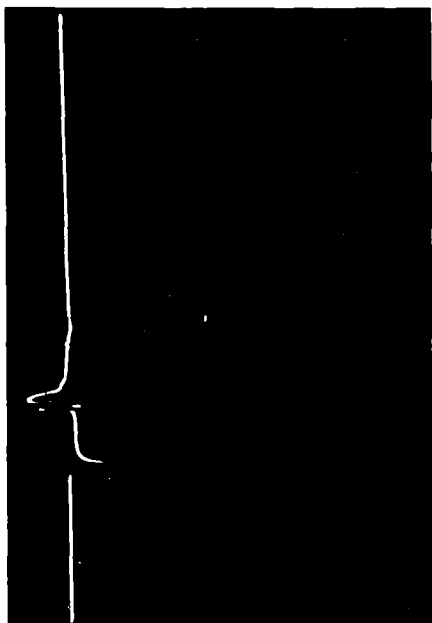

(c) Pulses Output, Matched

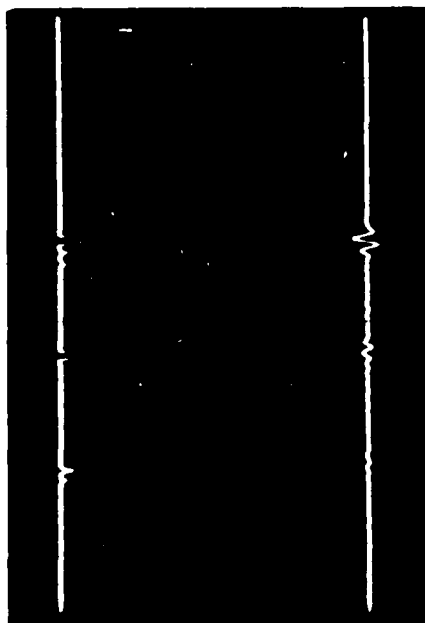

(d) Return Signals, Matched



(a) Pulses Output, Unmatched

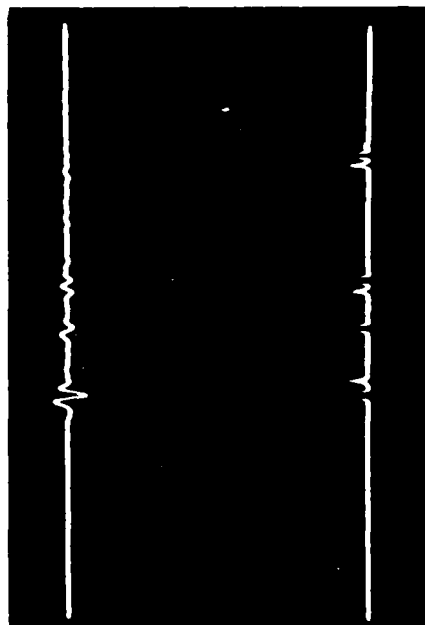

(b) Return Signals, Unmatched

FIGURE 13, WAVEFORM COMPARISONS

Formulae developed in this paper for impedance matching of cables and transducers will be useful in matching problems occurring in other systems. Of particular interest is that terminating a cable in its characteristic impedance eliminates the dependence of input impedance on cable length. Thus, the same network will work on both long and short cables. Although the transducer's impedance affects network design, most commonly used ultrasonic transducers have a capacitance near 1000 picofarads; thus, relatively few different network designs can accommodate most common transducers.

RECOMMENDATIONS

It is recommended that all cables used for underwater ultrasonic testing be impedance matched during construction of the waterproofed electrical termination.

DISTRIBUTION LIST

	<u>Copy No.</u>
743 Supervisor of Salvage (SEA 00C), Naval Sea Systems Command, Washington, DC 20362	1-3
457 Oceanographer of the Navy, Alexandria, VA 22332 (Attn: Management Information Division)	4
744 CAPT W. F. Searle, USN (Ret), 808 Timer Branch Parkway, Alexandria, VA 22302	5
059 Commander in Chief, US Atlantic Fleet, Norfolk, VA 23511	6
060 Commander in Chief, US Pacific Fleet, Pearl Harbor, HI 96860	7
062 Commander Naval Surface Force, US Atlantic Fleet, Norfolk, VA 23511	8
167 Commander Naval Surface Force, US Pacific Fleet, Naval Amphibious Base, Coronado, San Diego, CA 92155	9
663 Commander Submarine Force, US Atlantic Fleet, Norfolk, VA 23511	10
745 Commander Submarine Force, US Pacific Fleet, Pearl Harbor, HI 96860	11
746 Commanding Officer, Naval Publications and Forms Center, 5801 Tabor Avenue, Philadelphia, PA 19120	12
427 Commander, Naval Sea Systems Command (SEA 00C)	13
483 Commanding Officer, Naval School, Explosive Ordnance Disposal, Naval Ordnance Station, Indian Head, MD 20640	14
259 Commanding Officer, Naval Submarine School, Box 700, Groton, CT 06340	15
102 Commanding Officer, Naval Submarine Training Center Pacific, Pearl Harbor, HI 96860 (Attn: Director, Diving Training Dept)	16
289 Commander, Operational Test and Evaluation Force, Naval Base, Norfolk, VA 23511	17
747 Officer in Charge, Naval Surface Force, US Atlantic Fleet, Readiness Support Group, Charleston, SC 29408	18
748 Officer in Charge, Naval Surface Force, US Pacific Fleet, Readiness Support Group, Mayport, FL 32228	19
749 Officer in Charge, Naval Surface Force Atlantic, Readiness Support Group, FBPO, Norfolk, VA 23511	20
107 Commanding Officer, Harbor Clearance Unit TWO, FPO New York 09501	21
106 Commanding Officer, Harbor Clearance Unit ONE, FPO San Francisco 96601	22
750 Commander, Service Group TWO, FPO New York 09501	23
751 Commander, Service Squadron TWO, FPO New York 09501	24
752 Commander, Service Squadron FOUR, FPO New York 09501	25

NCSC TM 325-81

753	Commander, Service Squadron SIX, Box 35, FPO New York 09501	26
383	Commander, Service Squadron EIGHT, Naval Station, Norfolk, VA 23511	27
778	Commander, Service Group ONE, FPO San Francisco 96601	28
780	Commander, Service Squadron THREE, FPO San Francisco 96601	29
781	Commander, Service Squadron FIVE, FPO San Francisco 96601	30
782	Commander, Submarine Squadron TWO, FPO New York 09501	31
783	Commander, Submarine Squadron FOUR, FPO New York 09501	32
784	Commander, Submarine Squadron SIX, FPO New York 09501	33
785	Commander, Submarine Squadron TEN, FPO New York 09501	34
786	Commander, Submarine Squadron FOURTEEN, FPO New York 09501	35
787	Commander, Submarine Squadron SIXTEEN, FPO New York 09501	36
788	Commander, Submarine Squadron 18, FPO New York 09501	37
789	Commander, Submarine Squadron ONE, FPO San Francisco 96601	38
790	Commander, Submarine Squadron THREE, San Diego, CA 92132	39
791	Commander, Submarine Squadron SEVEN, FPO San Francisco 96601	40
792	Commander, Submarine Squadron FIFTEEN, FPO San Francisco 96601	41
309	Commander, Submarine Development Group ONE, 139 Sylvester Rd., San Diego, CA 92106	42
793	Officer in Charge, Detachment Alameda, Submarine Development Group ONE, Naval Air Station, Alameda, CA 94501	43
794	Officer in Charge, Detachment Mare Island, Submarine Development Group ONE, Mare Island Naval Shipyard, Vallejo, CA 94592	44
795	Commanding Officer, USS PIEDMONT (AD 17), FPO New York 09543	45
796	Commanding Officer, USS PRAIRIE (AD 15), FPO San Francisco 96639	46
797	Commanding Officer, USS PUGET SOUND (AD 38), FPO New York 09544	47
798	Commanding Officer, USS SHENADOAH (AD 26), FPO New York 09501	48
799	Commanding Officer, USS SIERRA (AD 18), FPO Miami 34084	49
800	Commanding Officer, USS YOSEMITE (AD 19), FPO Miami 34083	50
801	Commanding Officer, USS BRYCE CANYON (AD 36), FPO San Francisco 96640	51
802	Commanding Officer, USS DIXIE (AD 14), San Francisco 96638	52
803	Commanding Officer, USS SAMUEL GOMPERS (AD 37), FPO San Francisco 96641	53
804	Commanding Officer, USS VULCAN (AR 5), FPO New York 09501	54
805	Commanding Officer, USS AJAX (AR 6), FPO San Francisco 96642	55
806	Commanding Officer, USS HECTOR (AR 7), FPO San Francisco 96643	56
807	Commanding Officer, USS JASON (AR 8), FPO San Francisco 96644	57
808	Commanding Officer, USS HOIST (ARS 40), FPO New York 09501	58
809	Commanding Officer, USS OPPORTUNE (ARS 41), FPO New York 09501	59
810	Commanding Officer, USS PRESERVER (ARS 8), FPO New York 09501	60
811	Commanding Officer, USS RECOVERY (ARS 43), FPO New York 09501	61
812	Commanding Officer, USS BOLSTER (ARS 38), San Francisco 96601	62
813	Commanding Officer, USS CONSERVER (ARS 39), FPO San Francisco 96601	63
814	Commanding Officer, USS RECLAIMER (ARS 42), FPO San Francisco 96601	64
815	Commanding Officer, USS CANOPUS (AS 34), FPO Miami 34087	65
816	Commanding Officer, USS FULTON (AS 11), FPO New York 09534	66
817	Commanding Officer, USS HOWARD W. GILMORE (AS 16), FPO New York 09534	67

NCSC TM 325-81

818	Commanding Officer, USS HOLLAND (AS 32), FPO New York 09534	68
819	Commanding Officer, USS HUNLEY (AS 31), FPO San Francisco 96601	69
820	Commanding Officer, USS ORION (AS 18), FPO Miami 34081	70
821	Commanding Officer, USS SIMON LAKE (AS 33), FPO Miami 34085	71
822	Commanding Officer, USS L. Y. SPEAR (AS 36), FPO New York 09547	72
823	Commanding Officer, USS DIXON (AS 37), FPO San Francisco 96648	73
824	Commanding Officer, USS PROTEUS (AS 19), FPO San Francisco 96646	74
825	Commanding Officer, USS SPERRY (AS 12), FPO San Francisco 96645	75
826	Commanding Officer, USS KITTIWAKE (ASR 13), FPO New York 09501	76
827	Commanding Officer, USS ORTOLAN (ASR 22), FPO New York 09501	77
828	Commanding Officer, USS PETRAL (ASR 14), FPO New York 09501	78
829	Commanding Officer, USS SUNBIRD (ASR 15), FPO New York 09501	79
830	Commanding Officer, USS FLORIKAN (ASR 9), FPO San Francisco 96601	80
831	Commanding Officer, USS PIGEON (ASR 21), FPO San Francisco 96601	81
832	Commanding Officer, USS PAIUTE (ATF 159), FPO New York 09501	82
833	Commanding Officer, USS PAPAGO (ATF 160), FPO New York 09501	83
834	Commanding Officer, USS SHAKORI (ATF 162), FPO New York 09501	84
835	Commanding Officer, USS MOCTOBI (ATF 105), FPO San Francisco 96601	85
836	Commanding Officer, USS QUAPAW (ATF 110), FPO San Francisco 96601	86
837	Commanding Officer, USS TAKELMA (ATF 113), FPO San Francisco 96601	87
838	Officer in Charge, YRST 2, Harbor Clearance Unit TWO, FPO New York 09501	88
839	Commanding Officer, USS EDENTON (ATS 1), FPO New York 09501	89
840	Commanding Officer, USS BEAUFORT (ATS 2), FPO San Francisco 96601	90
841	Commanding Officer, USS BRUNSWICK (ATS 3), FPO San Francisco 96601	91
842	Officer in Charge, Underwater Construction Team ONE, Naval Amphibious Base, Little Creek, Norfolk VA 23521	92
843	Officer in Charge, Underwater Construction Team TWO, Naval Construction Battalion Center, Port Hueneme, CA 93043	93
844	Director, Hawaii Laboratory, Naval Ocean Systems Center, Kaneohe, HI 96863	94
354	Commander, Annapolis Laboratory, David W. Taylor Naval Ship Research & Development Center, Annapolis, MD 21402	95
487	Commander, Annapolis Laboratory, David W. Taylor Research & Development Center, Bethesda, MD 20034	96
845	Officer in Charge, Fort Lauderdale Facility, Naval Surface Weapons Center, 1650 SW 39th St., Fort Lauderdale, FL 33315	97
498	Commanding Officer, New London Laboratory, Naval Underwater Systems Center, New London, CT 06320	98
846	Officer in Charge, Newport Laboratory, Naval Underwater Systems Center, Newport, RI 02840	99
847	Officer in Charge, Civil Engineering Laboratory, Naval Construction Battalion Center, Port Heuneme, CA 93043	100

NCSC TM 325-81

210	Officer in Charge, White Oak Laboratory, Naval Surface Weapons Center, Silver Spring, MD 20910	101
848	Officer in Charge, Solomons Facility, Naval Surface Weapons Center, Solomons, MD 20688	102
849	Officer in Charge, Naval Underwater Systems Center, AUTEK West Palm Beach Detachment, West Palm Beach, FL 33402	103
850	Officer in Charge, Naval Underwater Systems Center, AUTEK Andros Ranges Detachment, FPO Miami 34058	104
851	Commanding Officer, Naval Submarine Base, New London, Box 00, Groton, CT 06340	105
852	Commanding Officer, Naval Submarine Base, Pearl Harbor, HI 96860	106
853	Commanding Officer, Naval Submarine Base, Bremerton, WA 98315	107
854	Commander, Naval Base, Box 110, Pearl Harbor, HI 96860	108
855	Commander, US Naval Ship Repair Facility, FPO San Francisco 98762	109
856	Commander, Naval Base, Boston, Fourth Naval District Headquarters, Philadelphia, PA 19112	110
177	Commander, Naval Base, Great Lakes, IL 60088	111
857	Commander, Naval Base, New York, Fourth Naval District Headquarters, Philadelphia, PA 19112	112
240	Commanding Officer, Naval Station, Annapolis, MD 21402	113
718	Commander, Naval Facilities Engineering Command, 200 Stovall Street, Alexandria, VA 22332	114
236	Commander, David W. Taylor Naval Ship Research & Development Center, Bethesda, MD 20034	115
278	Commanding Officer, Naval Underwater Systems Center, Newport, RI 02840	116
265	Commander, Naval Ocean Systems Center, San Diego, CA 92132	117
858	Commanding Officer, Chesapeake Division, Naval Facilities Engineering Command, Washington Navy Yard, Washington, DC 20374	118
859	Commanding Officer, Naval Undersea Warfare Engineering Station, Keyport, WA 98345	119
197	Commanding Officer, Naval Explosive Ordnance Disposal Facility, Indian Head, MD 20640	120
299	Commander, Puget Sound Naval Shipyard (Code 135), Bremerton, WA 98314	121
045	Commander, Charleston Naval Shipyard (Code 135), Naval Base, Charleston, SC 29408	122
124	Commander, Long Beach Naval Shipyard (Code 133), Long Beach, CA 90801	123
293	Commander, Pearl Harbor Naval Shipyard (Code 135), Box 400, Pearl Harbor, HI 96860	124
297	Commander, Philadelphia Naval Shipyard (Code 138.1), Philadelphia, PA 19112	125
298	Commander, Portsmouth Naval Shipyard (Code 135), Portsmouth, NH 03801	126
860	Civil Engineering Corps Officers School, Naval Construction Battalion Center, Port Hueneme, CA 93043	127
861	Commander, Mare Island Naval Shipyard (Code 135), Vallejo, CA 94592	128

NCSC TM 325-81

862	Officer in Charge, Engineering Duty Officer School, Mare Island, Vallejo, CA 94592	129
863	Commanding Officer, Naval School, Explosive Ordnance Disposal, Naval Ordnance Station, Indian Head, MD 20640	130
864	Commanding Officer, RHCU DET 522, Naval Reserve Center, 860 Terry Ave., N., Seattle, WA 98109	131
865	Commanding Officer, RHCU DET 614, Naval Reserve Center, 530 Peltier Ave., Honolulu, HI 96818	132
866	Commanding Officer, RHCU DET 101, Naval Reserve Center, Bldg. 272, Portsmouth Naval Shipyard, Portsmouth, NH 03301	133
867	Commanding Officer, RHCU DET 201, Naval Reserve Center, Davol Street, Fall River, MA 02720	134
868	Commanding Officer, RHCU DET 304, Naval Reserve Center, Bldg. 662, Naval Base, Philadelphia, PA 19112	135
869	Commanding Officer, RHCU DET 405, Naval Reserve Center, 1089 E. 9th St., Cleveland, OH 44114	136
870	Commanding Officer, RHCU DET 506, Naval & Marine Corps Reserve Center, Naval Amphibious Base, Little Creek, Norfolk, VA 23520	137
871	Commanding Officer, RHCU DET 608, Naval & Marine Corps Reserve Center, Naval Amphibious Base, Little Creek, Norfolk, VA 23520	138
872	Commanding Officer, RHCU DET 608, Naval & Marine Corps Reserve Center, Box 44, Bldg 411, Naval Air Station, Jacksonville, FL 32212	139
873	Commanding Officer, RHCU DET 708, Naval Reserve Center, 2610 Tigertail Avenue, Miami, FL 33133	140
874	Commanding Officer, RHCU DET 813, Naval Reserve Center, Randolph St at Lake Michigan, Chicago, IL 60601	141
875	Commanding Officer, RHCU DET 110, Naval Reserve Center, Bldg 84, NAS, Corpus Christi, TX 78419	142
876	Commanding Officer, RHCU DET 220, Naval & Marine Corps Reserve Center, Bldg 2, Treasure Island, San Francisco, CA 94130	143
877	Commanding Officer, RHCU DET 319, Naval Reserve Center, Naval Support Activity, Long Beach, CA 90801	144
878	Commanding Officer, RHCU DET 419, Naval Reserve Center, Camp Decatur, NTC, San Diego, CA 92133	145
879	Officer in Charge, Naval Submarine Training Center, Pacific Detachment, 140 Sylvester Road, Ballast Point, San Diego, CA 92106	146
880	Officer in Charge, Naval Education & Training Program, Development Center Detachment, Pensacola, FL 32511	147
881	Officer in Charge, Naval Instructional Program, Development Detachment, Great Lakes, IL 60088	148
882	Officer in Charge, PERA (CSS), Naval Sea Systems Command, c/o Supervisor of Shipbuilding, Conversion and Repair, US Navy, San Francisco, CA 94135	149
002	Director of Navy Laboratories, Room 300, Crystal Plaza, Bldg 5, Washington, DC 20390	150
883	Commandant, US Coast Guard, 400 7th St., SW, Washington, DC 20590	151

NCSC TM 325-81

884	Commanding Officer, Naval Reserve Center, Portsmouth Naval Shipyard, Portsmouth, NH 03801	152
516	Naval Special Warfare Group TWO, Little Creek, Norfolk, VA 23521	153
885	SSF Diving Locker, US Submarine Base, Box 300, Groton, CT 06340	154
886	Sub-Board of Inspection & Survey, Pacific, Bldg 226, P. O. Box 107, Naval Station, San Diego, CA 92136	155
887	Underwater Construction Team 1, NAB Little Creek, Norfolk, VA	156
888	Commanding Officer, Southern Division, Naval Facilities, Engineering Command (Code 406), P. O. Box 10068, Charleston, SC 29411	157
889	Navy Environmental Health Center, 3333 Vine, Cincinnati, OH 45220	158
890	Office of Naval Research, Code 484, Arlington, VA 22217	159
891	Chairman, Federal Maritime Commission, 1100 L St., NW, Washington, DC 20573	160
892	Supervisor of Salvage, USN, West Coast Representative, Bldg 7, Room 82, Naval Station Treasure Island, San Francisco, CA 94130	161
893	National Geographic Society Library, 1146 16th St., NW, Washington, DC 20036	162
170	BUDS Training, Naval Amphibious School, Coronado, San Diego, CA 92155	163
894	US Naval Academy, Nimitz Library, Annapolis, MD 21402	164
895	Asst. Supervisor of Salvage, USN (Admiralty), Room 1313, Federal Office Building, 90 Church St., New York NY 10007	165
896	Naval Sea Systems Command (PMS-395), Washington, DC 20362	166
652	Commanding Officer, Pacific Missile Range Facility, Hawaiian Area, Braking Sands, Kekaha, Kauai, HI 96752	167
897	Commanding Officer, Naval Submarine Support Facility, New London, Groton, CT 06340	168
898	Commanding Officer, Underwater Demolition Team 22, FPO New York 09501	169
899	Chief of Naval Technical Training, Training Coordinator for Diving & Salvage, Naval Air Station, Memphis, Millington, TN 38054	170
900	PCO, FRANK CABLE (AS 40), Supervisor of Shipbuilding, Conversion & Repair, USN, Seattle, WA 98115	171
901	PCO, EMORY S. LAND (AS 39), Supervisor of Shipbuilding, Conversion & Repair, USN Seattle, WA	172
258	Commanding Officer, Naval Submarine Medical Research Laboratory, Box 900, Naval Submarine Base, Groton, CT 06340	173
---	Repair Officer, USS PROTEUS (AS 19), FPO San Francisco 96646	174
---	Repair Officer, USS SPERRY (AS 12), FPO San Francisco 96645	175
---	Repair Officer, USS DIXON (AS 37), FPO San Francisco 96648	176
---	Repair Officer, USS HUNLEY (AS 31), FPO San Francisco 96647	177
---	Repair Officer, USS FULTON (AS 11), FPO New York 09534	178
---	Repair Officer, USS GILMORE (AS 16), FPO New York 09534	179
---	Repair Officer, USS HOLLAND (AS 32), FPO New York 09536	180

NCSC TM 325-81

---	Repair Officer, USS LAND (AS 39), FPO New York 09545	181
---	Repair Officer, USS SPEAR (AS 36), FPO New York 09547	182
---	Repair Officer, USS CABLE (AS 40), FPO Miami 34086	183
---	Repair Officer, USS CANOPUS (AS 34), FPO Miami 34087	184
---	Repair Officer, USS SIMON LAKE (AS 33), FPO Miami 34085	185
---	Repair Officer, USS ORION (AS 18), FPO Miami 34081	186
---	Repair Officer, USS AJAX (AR 6), FPO San Francisco 96642	187
---	Repair Officer, USS BRYCE CANYON (AD 36), FPO San Francisco 96640	188
---	Repair Officer, USS DIXIE (AD 14), FPO San Francisco 96638	189
---	Repair Officer, USS GOMPERS (AD 37), FPO San Francisco 96641	190
---	Repair Officer, USS HECTOR (AR 7), FPO San Francisco 96643	191
---	Repair Officer, USS JASON (AR 8), FPO San Francisco 96644	192
---	Repair Officer, USS PRARIE (AD 15), FPO San Francisco 96639	193
---	Repair Officer, USS PIEDMONT (AD 17), FPO New York 09543	194
---	Repair Officer, USS PUGET SOUND (AD 38), FPO New York 09544	195
---	Repair Officer, USS SIERRA (AD 18), FPO Miami 34084	196
---	Repair Officer, USS YOSEMITE (AD 19), FPO Miami 34083	197
---	Commanding Officer, SIMA, Naval Station, San Diego, CA 92136	198
---	Commanding Officer, SIMA, Naval Station, Charleston, SC 29408	199
---	Commanding Officer, SIMA, Naval Base, Mayport, FL 32228	200
---	Commanding Officer, SIMA, Naval Base, Norfolk, VA 23511	201
---	Commanding Officer, SIMA, Naval Amphibious Base, Little Creek, VA 23511	202
---	Commanding Officer, SIMA, Naval Station, Pearl Harbor, HI 96860	203
---	Commanding Officer, SUBASE, Pearl Harbor, HI 96800	204
250	Commanding Officer, Norfolk Naval Shipyard (Code 135), Portsmouth, VA 23709	205
---	Commanding Officer, USS CABLE (AS 40), FPO Miami 34086	206
---	Commanding Officer, USS LAND (AS 39), FPO New York 09545	207
075	Director, Defense Technical Information Center	208-217

DATE
ILME