

AD-A107 994

ARMY ENGINEER WATERWAYS EXPERIMENT STATION VICKSBURG--ETC F/G 13/13
COMPARISON OF VIBRATION TEST RESULTS FOR A MODEL AND PROTOTYPE --ETC(U)
OCT 81 C D NORMAN, H E STONE

UNCLASSIFIED WES/TR/SL-81-7

NL

1 of 1

4x4

11/1/82

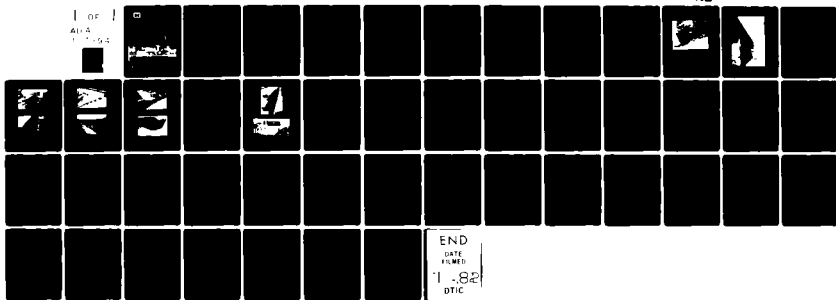

END
DATE
FILMED
11-82
DTIC

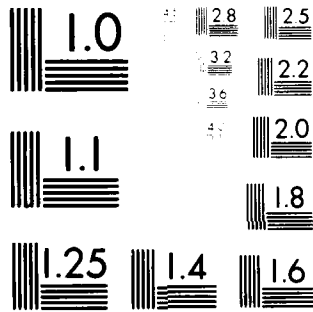

MICROCOPY RESOLUTION TEST CHART
NATIONAL BUREAU OF STANDARDS-1963-A

2

FINAL

2

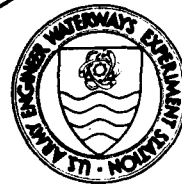

TECHNICAL REPORT SL-81-7

COMPARISON OF VIBRATION TEST RESULTS FOR A MODEL AND PROTOTYPE GRAVITY DAM

by

C. Dean Norman, Harry E. Stone

Structures Laboratory
U. S. Army Engineer Waterways Experiment Station
P. O. Box 631, Vicksburg, Miss. 39180

AD A 107994

October 1981

Final Report

Approved For Public Release; Distribution Unlimited

DTIC
ELECTE
DEC 2 1981
S
A



Prepared for Office, Chief of Engineers, U. S. Army
Washington, D. C. 20314

Under Work Unit 31273

DTIC FILED

81 12 01 078

**Destroy this report when no longer needed. Do not return
it to the originator.**

**The findings in this report are not to be construed as an official
Department of the Army position unless so designated,
by other authorized documents.**

**The contents of this report are not to be used for
advertising, publication, or promotional purposes.
Citation of trade names does not constitute an
official endorsement or approval of the use of
such commercial products.**

14. WEB/TKT

Unclassified

SECURITY CLASSIFICATION OF THIS PAGE (When Data Entered)

REPORT DOCUMENTATION PAGE		READ INSTRUCTIONS BEFORE COMPLETING FORM
1. REPORT NUMBER Technical Report SL-81-7	2. GOVT ACCESSION NO. AD-A107 994	3. RECIPIENT'S CATALOG NUMBER
4. TITLE (and Subtitle) COMPARISON OF VIBRATION TEST RESULTS FOR A MODEL AND PROTOTYPE GRAVITY DAM		5. TYPE OF REPORT & PERIOD COVERED Final report.
7. AUTHOR(s) C. Dean/Norman Harry E. Stone		6. PERFORMING ORG. REPORT NUMBER Sep 76 - Feb 77
8. PERFORMING ORGANIZATION NAME AND ADDRESS U. S. Army Engineer Waterways Experiment Station Structures Laboratory P. O. Box 631, Vicksburg, Miss. 39180		9. CONTRACT OR GRANT NUMBER(s)
11. CONTROLLING OFFICE NAME AND ADDRESS Office, Chief of Engineers, U. S. Army Washington, D. C. 20314		10. PROGRAM ELEMENT, PROJECT, TASK AREA & WORK UNIT NUMBERS Work Unit No. 31273
14. MONITORING AGENCY NAME & ADDRESS (if different from Controlling Office)		11. REPORT DATE October 1981
12 MIC		13. NUMBER OF PAGES 42
15. DISTRIBUTION STATEMENT (of this Report) Approved for public release; distribution unlimited.		14. SECURITY CLASS. (of this report) Unclassified
17. DISTRIBUTION STATEMENT (of the abstract entered in Block 20, if different from Report)		15. DECLASSIFICATION/DOWNGRADING SCHEDULE
18. SUPPLEMENTARY NOTES Available from National Technical Information Service, 5285 Port Royal Road, Springfield, Va. 22151.		
19. KEY WORDS (Continue on reverse side if necessary and identify by block number) Concrete dams Pine Flat Dam Gravity dams Prototype tests Model tests Vibration response tests		
20. ABSTRACT (Continue on reverse side if necessary and identify by block number) A 1:60-scale model of the Pine Flat concrete gravity dam was constructed and subjected to steady state forced vibration tests. Natural frequencies, mode shapes, damping, and hydrodynamic pressures were measured during these tests. These results were compared with similar results obtained in the prototype test program previously conducted. Also two-dimensional and three-dimensional finite element analyses were performed to obtain analytical values.		

(Continued)

DD FORM 1 JAN 73 1473

EDITION OF 1 NOV 65 IS OBSOLETE

Unclassified

SECURITY CLASSIFICATION OF THIS PAGE (When Data Entered)

A
421415

12

Unclassified

SECURITY CLASSIFICATION OF THIS PAGE(When Data Entered)

20. ABSTRACT (Continued).

for natural frequencies and mode shapes.

Model and prototype test results compared favorably with those from the three-dimensional finite element analyses. The reservoir was observed to have little effect on the natural frequencies and mode shapes of the model dam. Furthermore, it was concluded that the dynamic characteristics of the continuous three-dimensional model compared favorably with those of the prototype which was constructed in monoliths.

Unclassified

SECURITY CLASSIFICATION OF THIS PAGE(When Data Entered)

CONTENTS

	<u>Page</u>
PREFACE	1
CONVERSION FACTORS, INCH-POUND TO METRIC (SI) UNITS OF MEASUREMENT	3
PART I: INTRODUCTION	4
PART II: MODEL CONSTRUCTION	5
PART III: EXPERIMENTAL PROCEDURES	12
Testing/Recording Equipment	12
Instrumentation	12
Vibration Tests	14
PART IV: TEST RESULTS	15
PART V: ANALYSIS/DISCUSSION OF RESULTS	17
Mode Shapes	19
Hydrodynamic Pressures	19
PART VI: CONCLUSIONS	20
Model and Prototype Test Results	20
Finite Element Analysis	20
REFERENCES	21
TABLES 1-4	
PLATES 1-15	
APPENDIX A: MODEL SCALING RELATIONS	A1

CONVERSION FACTORS, INCH-POUND TO METRIC (SI)
UNITS OF MEASUREMENT

Inch-pound units of measurement used in this report can be converted to metric (SI) units as follows:

<u>Multiply</u>	<u>By</u>	<u>To Obtain</u>
feet	0.3048	metres
inches	25.4	millimetres
pounds (force)	4.448222	newtons
pounds (force) per square inch	6.894757	kilopascals
pounds (mass)	0.45359237	kilograms
pounds (mass) per cubic foot	16.01846	kilograms per cubic metre

COMPARISON OF VIBRATION TEST RESULTS FOR
A MODEL AND PROTOTYPE GRAVITY DAM

PART I: INTRODUCTION

1. In order to develop more efficient design procedures for concrete gravity dams subjected to earthquake forces, an understanding of the significant parameters that influence the dynamic properties of such structures is necessary. Assumptions regarding geometry, boundary conditions, and interaction with the foundation and reservoir significantly affect earthquake response calculations. Currently, most earthquake structural analyses for concrete dams are carried out using modern computational methods (e.g., finite element analysis) with high-speed computers. Developing confidence in the results from these analyses is very important but also very difficult. Vibration tests provide a means of simulating seismic-type motions, which in turn contribute to the determination of dynamic properties of dams and to the evaluation of various parameters that influence these properties. Dynamic properties which are of primary importance in the earthquake analysis of concrete dams include natural frequencies, mode shapes, damping, foundation interaction, and hydrodynamic interaction. These dynamic properties can be experimentally determined and then used to verify modern computational procedures currently being developed for the dynamic analysis of large concrete structures.

2. The Pine Flat Dam program was initiated in an effort to effectively study the dynamic response characteristics of a typical concrete gravity dam through the use of model and prototype vibration tests together with three-dimensional (3D) linear dynamic finite element analyses. Results of the prototype tests have previously been reported by Rea, Liaw, and Chopra (1972). Results of the model tests and analysis together with comparisons with prototype test results are reported herein.

PART II: MODEL CONSTRUCTION

3. Pine Flat Dam (Figure 1), located on the Kings River near Fresno, Calif., was constructed about 25 years ago. It is a concrete gravity dam with a straight crest 1840 ft long,* a maximum height of 400 ft, and a crown thickness of 32 ft. The overflow spillway is a section 292 ft long and is depressed about 58.5 ft below the normal crest elevation. The dam consists of thirty-seven 50-ft-wide monoliths with typical geometries as shown in Plate 1.

4. The 1:60-scale model of Pine Flat Dam which was designed to scale elastic forces is shown in Figure 2. The general concept used in this study was to provide a massive concrete foundation which would simulate the foundation of the prototype dam. Overall dimensions of the dam, foundation, and reservoir are presented in Plates 2 and 3. The model reservoir consists of an 8-in. layer of concrete extending upstream approximately 30 ft. The side slopes of the reservoir were maintained at those slopes existing at the intersection with the dam. Little test data exists concerning the material properties of the prototype dam. Limited tests conducted around 1952 indicated that the elastic modulus E_c ranged from 1.1 to 4.3 million psi. Natural frequencies determined from vibration tests on the prototype (Rea, Liaw, and Chopra 1972), when normalized with respect to $\sqrt{E_c}$ and compared to three-dimensional finite element analyses, indicated the elastic modulus should be around 3.25 million psi. Due to lack of information concerning prototype foundation material properties, the foundation for the model was designed to be similar in elastic properties to that of the model structure. The ultimate concrete compressive strength f'_c and static modulus E_c for the model dam and foundation are shown below:

$$\begin{aligned} \text{Model:} \quad & f'_c = 3388 \text{ psi} \\ & E_c = 3.15 \times 10^6 \text{ psi} \end{aligned}$$

* A table of factors for converting inch-pound units of measurement to metric (SI) units is presented on page 3.

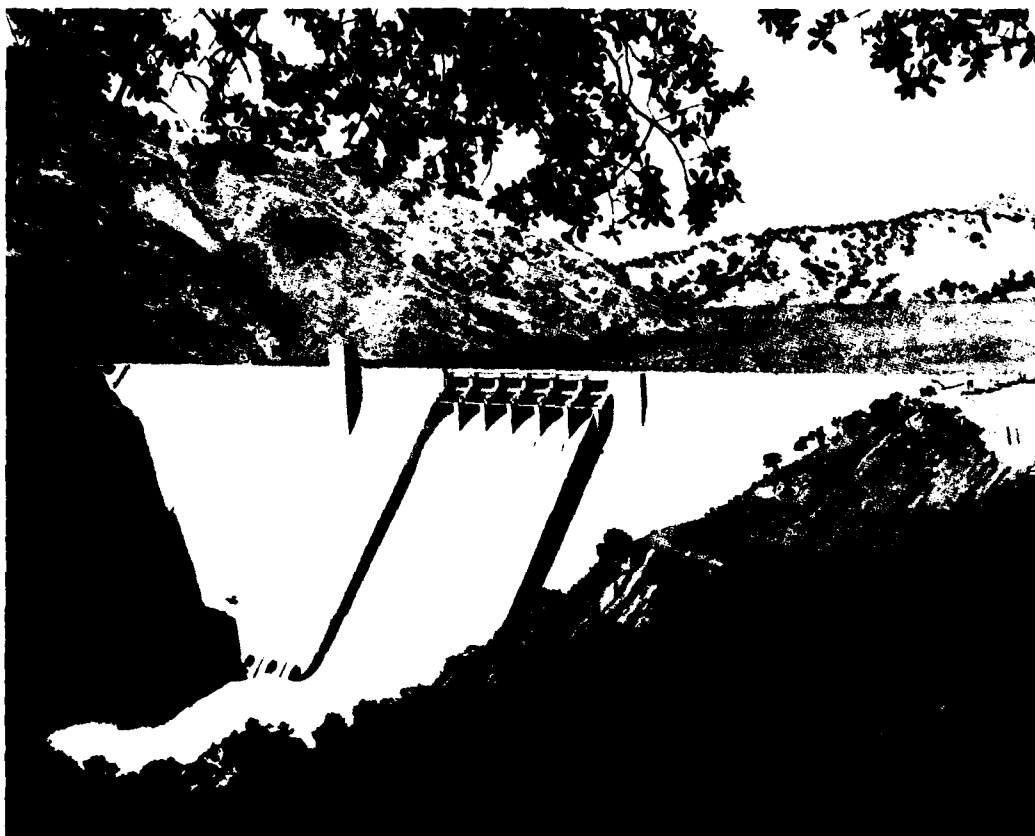

Figure 1. Pine Flat concrete gravity dam



Figure 2. Pine Flat Dam model

Foundation: $f'_c = 2800$ psi
 $E_c = 2.58 \times 10^6$ psi

These concrete material properties were determined in accordance with CRD-C14-73 and CRD-C19-75 (U. S. Army Engineer Waterways Experiment Station 1949), and are based on 28-day strength. The rate of loading for these tests was in the range of 20 to 50 psi/sec.

5. In constructing the model, concrete for the massive foundation block (Figure 3) was placed first and allowed to cure. As shown in Figure 3, the foundation block was reinforced to insure elastic resistance of any stresses produced by settlement. Also as shown in Figure 3, the foundation block was constructed to provide a stair step supporting condition for the model dam which simulates those conditions existing for the prototype. The required overall size of the foundation block (Plates 2 and 3) was based primarily on results from previous model tests (Norman, Crowson, and Balsara 1976). These model tests indicated that a foundation the size used herein seemed to adequately simulate prototype conditions in regards to effects on natural frequencies and mode shapes.

6. After the foundation had cured, forms for the model dam were constructed on the foundation block as shown in Figure 4. The top surface of the concrete foundation was sprayed with water just after initial set in order to provide a rough surface for the concrete dam to be placed on. The surface of the foundation was intended to simulate in a qualitative way the scaled roughness of the prototype dam. Considerable bracing was required for the formwork in order to prevent uplift and distressing of the forms themselves. Next, the model dam was cast in a continuous concrete pour and allowed to cure for 28 days. The monolith joints of the prototype were not simulated in the model. This decision was made partly because of the time and costs involved and also because the prototype study (Rea, Liaw, and Chopra 1972) had indicated that the dam responds primarily in 3D modes at low levels of harmonic excitation. An aluminum powder additive was used in the concrete mix to minimize the amount of temperature and settlement cracking in the model. The completed model, with instrumentation in place, is shown in Figure 5.



a. Placement of concrete

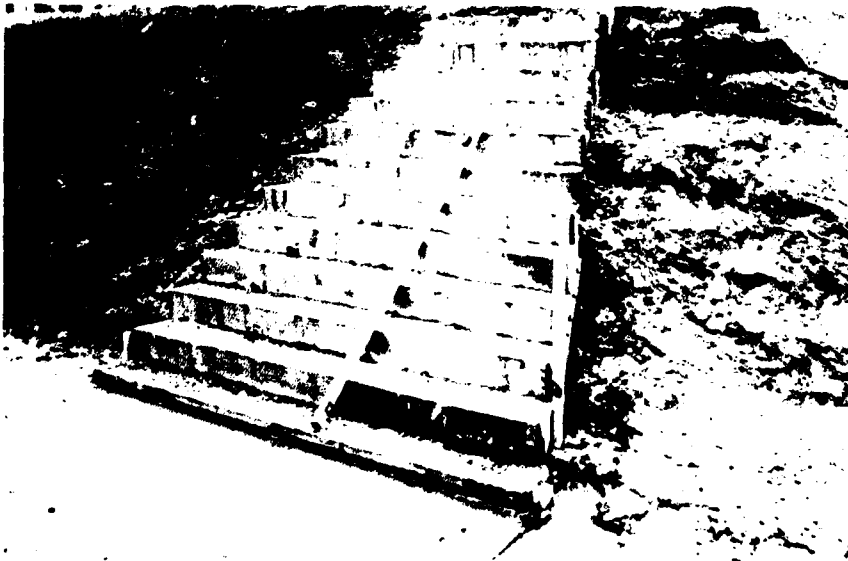

b. Final geometry

Figure 3. Foundation block construction



a. Detail of dam-foundation interface

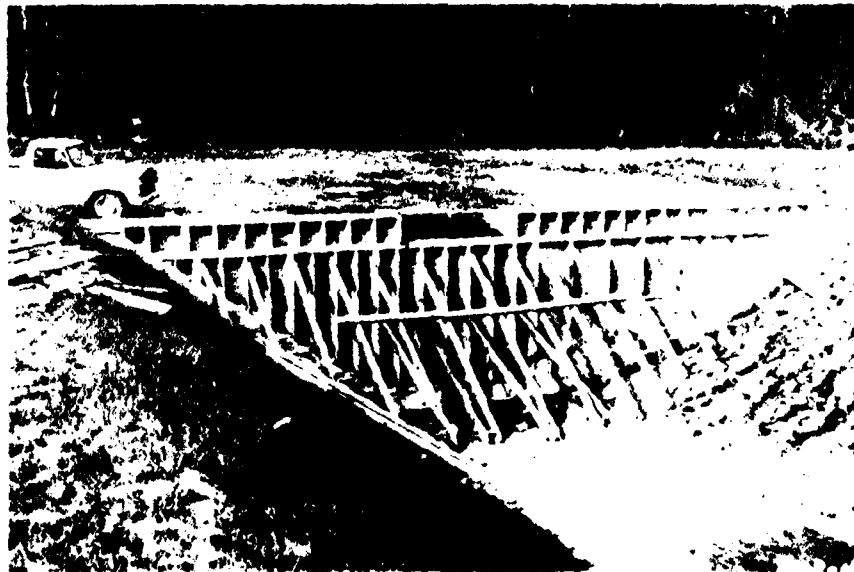

b. Upstream view of model dam formwork

Figure 4. Construction of model dam section

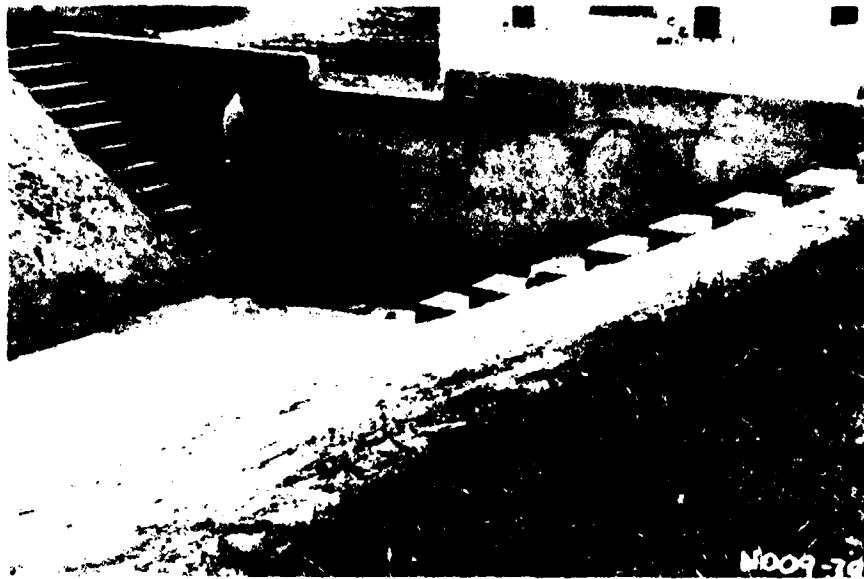

a. View from upstream with instrumentation and vibrator in place

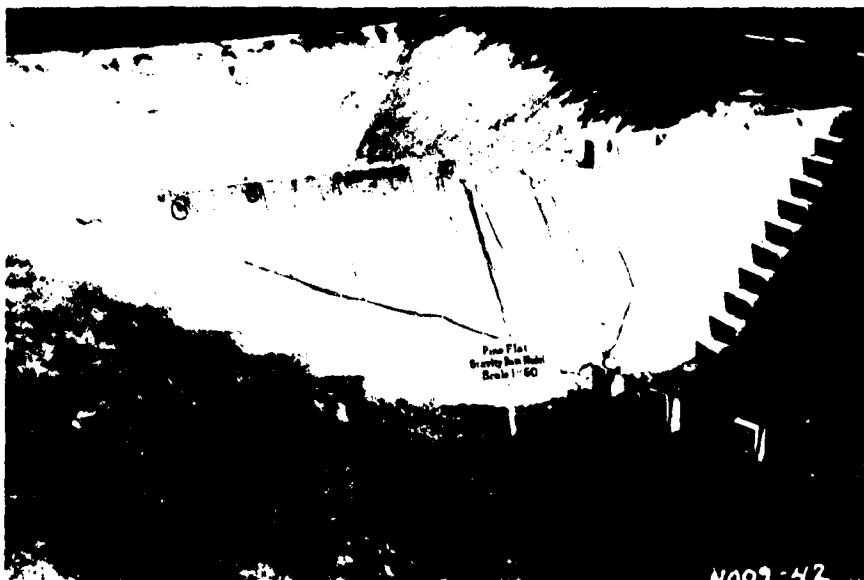

b. View from downstream

Figure 5. Completed model of Pine Flat Dam

PART III: EXPERIMENTAL PROCEDURES

Testing/Recording Equipment

7. Zonic Technical Laboratories Model No. ES-301 Inertial Mass Exciters were used to excite the dam. These units are self-contained point force sources capable of applying dynamic excitation forces independent of a ground plane. Aluminum mounting plates were affixed to the vertical face of the dam near the crest with an epoxy adhesive and the vibrators then bolted to the plate. These particular shakers are a combination of an exciter head with displacement control and a guided 55-lb mass and are capable of up to 1000 lb peak dynamic force with a frequency range from 2 to 1000 Hz.

8. An automatic mechanical impedance analysis system, Spectral Dynamics Model SD 1002E, was used for test control and data analysis. This system consisting of a controller, frequency log converter, tracking filter, sweep oscillator, and co-quad analyzer can be used with on-line or signal playbacks. An equipment list and specifications are given in Table 1.

Instrumentation

9. Structural response was measured by piezoelectric accelerometers, Endevco Model 2219E, which have a charge sensitivity of 85 picocoulombs/g (pC/g) (+20 percent), a mounted natural frequency of 16 kHz (+10 percent), and a frequency response of 2 to 3000 Hz (+5 percent). One-inch-cube plastic mounting blocks were epoxyed to the structure and gages then attached to the blocks, thus being electrically isolated. Signals from the piezo gages were amplified by charge amplifiers, Kistler Model 504D, before being recorded on magnetic tape. The instrumentation plan for the tests is presented in Plates 4 and 5. Typical test setups for empty reservoir with one vibrator and full reservoir with two vibrators are shown in Figure 6.



a. Empty reservoir with one vibrator



b. Full reservoir with two vibrators

Figure 6. Vibration tests set up

Vibration Tests

10. Constant force, sinusoidal, frequency sweep tests were conducted on the model dam. Tests were run using a single vibrator as well as using two phase-controlled vibrators. In order to excite both symmetric and asymmetric modes, the two vibrators were driven in-phase and 180 degrees out-of-phase. For all tests the frequency was swept over the range of interest at a rate of 0.4 decades per minute, which corresponds to a rate of 6 Hz/sec for these tests. This rate was considered to produce a quasi-steady state condition; i.e., results at this rate were no different from those at a slower rate. The reservoir depth was varied in these tests from the empty to full condition. A summary of vibration tests conducted on the model dam is presented in Table 2. Many tests were conducted for calibration or to evaluate instrumentation precision and are not presented in Table 2.

PART IV: TEST RESULTS

11. Natural frequencies determined from the frequency sweep tests discussed in Part III are presented in Table 3. Also presented in Table 3 are the natural frequencies determined during vibration tests of the prototype dam (Rea, Liaw, and Chopra 1972). Due to insensitivity of measured model dam natural frequencies to reservoir depth, only full and empty test results are presented in Table 3. To excite mode 1, both vibrators were driven in-phase. For all other excitable modes, no measurable difference was detected from different tests (Table 2).

12. Damping as a percent of critical is presented in Table 3 for various modes of vibration of the model dam. Damping values were determined by the co-response method, as discussed by Smallwood (1970), using the formula

$$\zeta_n = \frac{1}{2} \frac{\left(\frac{W_a}{W_b}\right)^2 - 1}{\left(\frac{W_a}{W_b}\right)^2 + 1}$$

where:

W_a = frequency of co-response peak > the natural frequency

W_b = frequency of co-response peak < natural frequency

13. Crest mode shapes for the first six modes of vibration are presented in Plate 6. The first mode ($f = 202$ Hz) was obtained running both vibrators in-phase. All other crest mode shapes were obtained using only one vibrator.

14. Cantilever mode shapes defined by accelerometers in a vertical line under A6 (Plate 4) are presented in Plate 7. All mode shapes are presented for the full reservoir case. As for the natural frequencies, there was no discernible difference between the mode shapes for the full reservoir and empty reservoir test cases.

15. Hydrodynamic pressures were measured along vertical lines defined by P_1 through P_7 in Plate 5. Maximum pressures as a function of depth are presented in Plates 8 and 9. For these tests the vibrators were operated at a force level of 200 lb.

16. At the tallest section of the dam (P_4 in Plate 7) hydrodynamic pressures versus depth for various vibration frequencies were measured; the results are presented in Plate 10. The vibrator force was maintained at 200 lb for this test also.

17. At the P_4 and P_6 locations (Plate 5), hydrodynamic pressure versus depth for three vibrator force levels (100, 150, and 200 lb) was measured and is presented in Plate 11.

PART V: ANALYSIS/DISCUSSION OF RESULTS

18. In order to evaluate the results of tests conducted on the model and prototype Pine Flat Dam, 2D and 3D finite element analyses were performed. The finite element grids used for these analyses are shown in Plate 12. A version of the finite element computer code SAPIV (Bath, Wilson, and Peterson 1974) was used for the analyses. For both 3D and 2D analyses, the 8-21 variable node element was used. The 3D grid was made up of 230 elements with 1749 degrees of freedom. All nodes at the dam-to-foundation interface were completely fixed. A plane strain formulation was used for the 2D model with 21 elements and 220 degrees of freedom. The nodes along the base of the 2D model were completely fixed also. Material properties assumed for the analyses were

$$\begin{aligned} \text{Elastic Modulus} & E_c = 3.15 \times 10^6 \text{ psi} \\ \text{Poisson's Ratio} & \nu = 0.25 \\ \text{Specific Weight} & \rho = 150 \text{ lb/ft}^3 \end{aligned}$$

19. Natural frequencies obtained from the model and prototype vibration tests along with those from the 3D and 2D finite element analyses are presented in Table 4. These frequencies are all scaled to the prototype dimensions. The effects of the reservoir were neglected when calculating natural frequencies by the finite element method. As mentioned previously, the reservoir had little effect on the model dam frequencies as determined by tests. For modes 1 through 4, the change in model frequency resulting from full or empty reservoir conditions ranged from 0.89 to 1.5 percent. The change in the mode 5 frequency was 5.8 percent. Similar changes observed in prototype frequencies were from 2.59 to 5.7 percent and 7.2 percent for mode 6. Except for mode 1, all model frequencies decreased when the reservoir was filled, which is to be expected due to the nature of dam-reservoir interaction. However, in the prototype tests, measured frequencies were seen to increase as the reservoir level was increased for all modes above the first. Although this increase was small, it was not expected and therefore was explained as the result of other effects such as temperature variations between tests. In the case of the model, only the mode 1 frequency increased when the reservoir was filled, and

this change in frequency was the smallest observed for modes 1-5. The comparison between model and prototype frequencies is quite good. The percentage difference Δf in natural frequencies for a particular mode based on comparison of model m , prototype p , or finite element analysis a results is defined here as (for results from the model and prototype tests)

$$\Delta f_{mp} = \frac{f_m - f_p}{f_p} \times 100$$

Similar formulas are obtained for Δf_{ma} and Δf_{pa} by changing the appropriate indices. Percentage differences for the first seven modes of dam vibration are presented below:

<u>Mode</u>	<u>Δf_{mp}</u>	<u>Δf_{ma}</u>	<u>Δf_{pa}</u>
1	2.0	12.6	10.8
2	7.5	13.4	6.4
3	--	9.8	--
4	2.4	6.43	8.6
5	9.3	0.6	8.0
6	16.2	5.0	9.6
7	--	--	0.3

In general, comparisons of natural frequencies for model, prototype, and finite element analysis are quite good. Natural frequencies from the 3D analysis are in all cases higher than the prototype frequencies as would be expected since the analysis did not include the effects of the reservoir, or the flexibility of the foundation. Each of these effects tends in general to lower natural frequencies. Analysis results were also higher than those measured for the model except for the fifth and sixth modes. However, there was very little percentage difference in model and finite element analysis frequencies for these two modes. The predicted natural frequencies from the 2D analysis should not be compared directly with similar modes from the vibration tests or the 3D analysis. The reason for this is that the model, prototype, and 3D finite element model are vibrating in 3D modes. To rationally compare results from the 2D finite element analysis with the 3D analysis or either test structure, the 3D cantilever model shape at the cross section which is geometrically similar to the 2D model should be used as the basis of comparison. Since only four accelerometers could be used in defining the cantilever mode shapes

for the model, it was difficult to precisely compare the mode shapes from the model test and those from the 2D analysis. However the first mode natural frequencies can be reasonably compared. When this is done, the 2D analysis is seen to yield a lower fundamental frequency, which is to be expected due to the more flexible nature of the plane strain assumption used in the 2D analysis.

Mode Shapes

20. Crest mode shapes from the model dam tests (Plate 6) are compared with results from prototype tests in Plate 13. In the prototype tests, mode 3 could not be excited. This was not the case for the model dam as can be seen in Plate 14. Crest mode shapes from the 3D analysis are presented in Plate 15 and can be seen to compare favorably with those from the model and prototype tests. Complete mode shapes from the 3D analysis (Plate 15) indicate at least qualitatively that the regions near the spillway might be critical regions from a stress concentration standpoint. However, results from prototype tests (Rea, Liaw, and Chopra 1972) indicated that the response to severe ground motion would tend to be more of a 2D nature, which should reduce the potential for stress concentrations in the corners of the spillway region.

Hydrodynamic Pressures

21. As can be seen in Plates 8-11, the hydrodynamic pressure on the dam is quite sensitive to the frequency and mode of vibration and also to the excitation force level. The form of the hydrodynamic pressure curves is emphasized here rather than the exact value of the pressures. The exact value of the pressure depends on the precision of the natural frequency and the time the structure is allowed to build up amplitudes in that particular mode. The sensitivity of pressure form to excitation frequency is demonstrated in Plate 10. The dependence of hydrodynamic pressure on excitation force is dramatically demonstrated in Plate 11. For the P_4 and P_6 pressure lines (Plate 7), the pressure near the crest is approximately doubled for a similar increase in excitation force.

PART VI: CONCLUSIONS

Model and Prototype Test Results

22. The dynamic response characteristics of both model and prototype dams were three-dimensional in nature for relatively low-level excitation forces. These characteristics are similar for model and prototype tests. The flexibility of the dam is important when considering hydrodynamic pressures. Also, the magnitude of hydrodynamic pressure depends strongly on the level of excitation force. Both model and prototype tests verify that structural damping in a concrete dam is in a range of 2 to 5 percent of critical for low-level excitation.

Finite Element Analysis

23. A linear finite element analysis such as the one presented herein provides a good method for predicting the linear dynamic response characteristics for concrete dams. With a relatively small number of elements, the first few mode shapes and natural frequencies were predicted quite accurately. The effects of the reservoir and foundation flexibility should, however, be included in the analysis of a concrete gravity dam subjected to severe earthquake motions.

REFERENCES

1. Bath, K. J., Wilson, E. L., Peterson, F. E., 1974. "SAPIV, A Structural Analysis Program for Static and Dynamic Response of Linear Systems," Report No. EERC 73-11, University of California, Berkeley, Calif.
2. Borges, J. F. and Perira, J. 1970. "Dynamic Model Studies for Designing Concrete Structures," ACI Publication No. 24, Paper SP 24-10, American Concrete Institute, Detroit, Mich.
3. Norman, C. D., Crowson, R. D., and Balsara, J. P. 1976. "Dynamic Response Characteristics of a Model Arch Dam," Technical Report N-76-3, U. S. Army Engineer Waterways Experiment Station, Vicksburg, Miss.
4. Rea, D., Liaw, C. Y., and Chopra, A. K. 1972. "Dynamic Properties of Pine Flat Dam," Report No. EERC 72-7, University of California, Berkeley, Calif.
5. Smallwood, D. O. 1970. "Experimental Model Studies," SC-DR-70-72, Sandia Laboratories, Albuquerque, N. Mex.
6. U. S. Army Engineer Waterways Experiment Station. 1949 (With Supplements). Handbook for Concrete and Cement, with quarterly supplements and revisions, Vicksburg, Miss.

Table 1
Equipment List

Accelerometer	Endevco Piezoelectric Model 2219E Charge sensitivity, pC/g.....85 ±20% Resonance frequency, kHz.....16 ±10% Frequency response (±5%), Hz....2 to 3000
Charge amplifier	Kistler 503-D
Tape recorder	
Record	Sangamo Sabre III
Playback	Sangamo
Automatic mechanical impedance measuring system	Spectral Dynamics SD 1002E
Sweep oscillator	SD 104A
Tracking filter	SD 122L
Log converter	SD 112-1
MZ/TFA controller	SD 127
Co-Quad analyzer	SD 109B
X-Y plotter	Hewlett Packard 135
Electrohydraulic vibrator	Zonic ES 301 Inertial Mass Exciter Static force (wt of head only) lb.....115 Dynamic force (pk. sinusoidal) lb.....1000 Stroke, in.....1.0 Frequency range, Hz.....2 to 1000 Total harmonic distortion.....<25% Operating pressure, psi.....3000

Table 2
Vibration Tests Conducted on
the Pine Flat Model Dam

<u>Test</u>	<u>Reservoir</u>	<u>Vibrator, Phase*</u>	<u>Frequency Range, Hz</u>
12	Full	1	400-1000
13	Full	1	100-500
14	Empty	1	100-500
17	Empty	1	400-1000
20	Full	2, IP	400-1000
21	Full	2, OP	400-1000
23	Full	2, OP	100-500
24	Full	2, IP	100-500
26	3/4 Full	2, IP	100-500
27	3/4 Full	2, OP	100-500
29	3/4 Full	2, OP	400-1000
30	3/4 Full	2, OP	400-1000
32	Empty	2, IP	400-1000
33	Empty	2, OP	400-1000
35	Empty	2, OP	100-500
36	Empty	2, IP	100-500
38	1/2 Full	2, IP	100-500
39	1/2 Full	2, OP	100-500
40	1/2 Full	2, OP	400-1000
41	1/2 Full	2, IP	400-1000
42	7/8 Full	2, IP	400-1000
43	7/8 Full	2, OP	400-1000
44	7/8 Full	2, OP	100-500
45	7/8 Full	2, IP	100-500

* IP - Vibrators driven in-phase.
 OP - Vibrators driven out-of-phase.

Table 3
Natural Frequencies and Damping for Model
and Prototype Dam (Model Frequencies
Scaled to Prototype)

Mode	Natural Frequency, Hz		Prototype	Model Percent Damping
	Model			
	Full	Empty		
1	3.4	3.37	4.47	--
2	3.82	3.88	4.13	4.6
3	4.67	4.72	--	3.3
4	5.53	5.58	5.40	4.4
5	6.67	7.08	6.10	3.3
6	7.55	--	6.50	5.8
7	--	--	7.47	--

Table 4
Comparison of Natural Frequencies From Model,
Prototype Tests, and Finite Element Analysis
(All Frequencies Scaled to Prototype)

Mode	Natural Frequency, Hz				
	Model		Prototype	Finite Element Analyses	
	Full	Empty		3D	2D
1	3.4	3.37	3.47	3.89	3.22
2	3.82	3.88	4.13	4.41	6.76*
3	4.67	4.72	--	5.18	8.89*
4	5.53	5.58	5.40	5.91	11.26*
5	6.67	7.08	5.10	6.63	--
6	7.55	--	6.50	7.19	--
7	--	--	7.47	7.49	--

* See the discussion in paragraph 19.

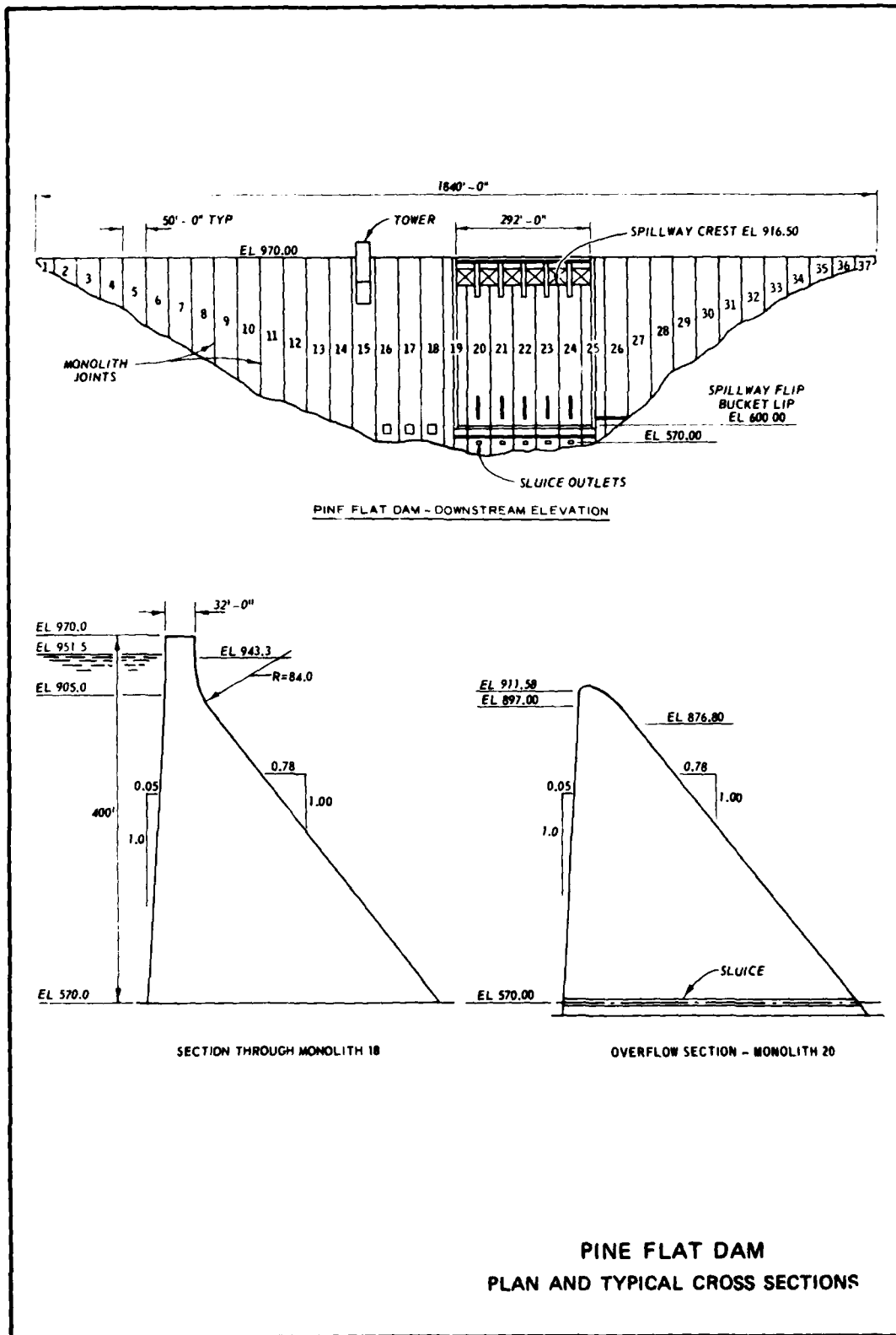

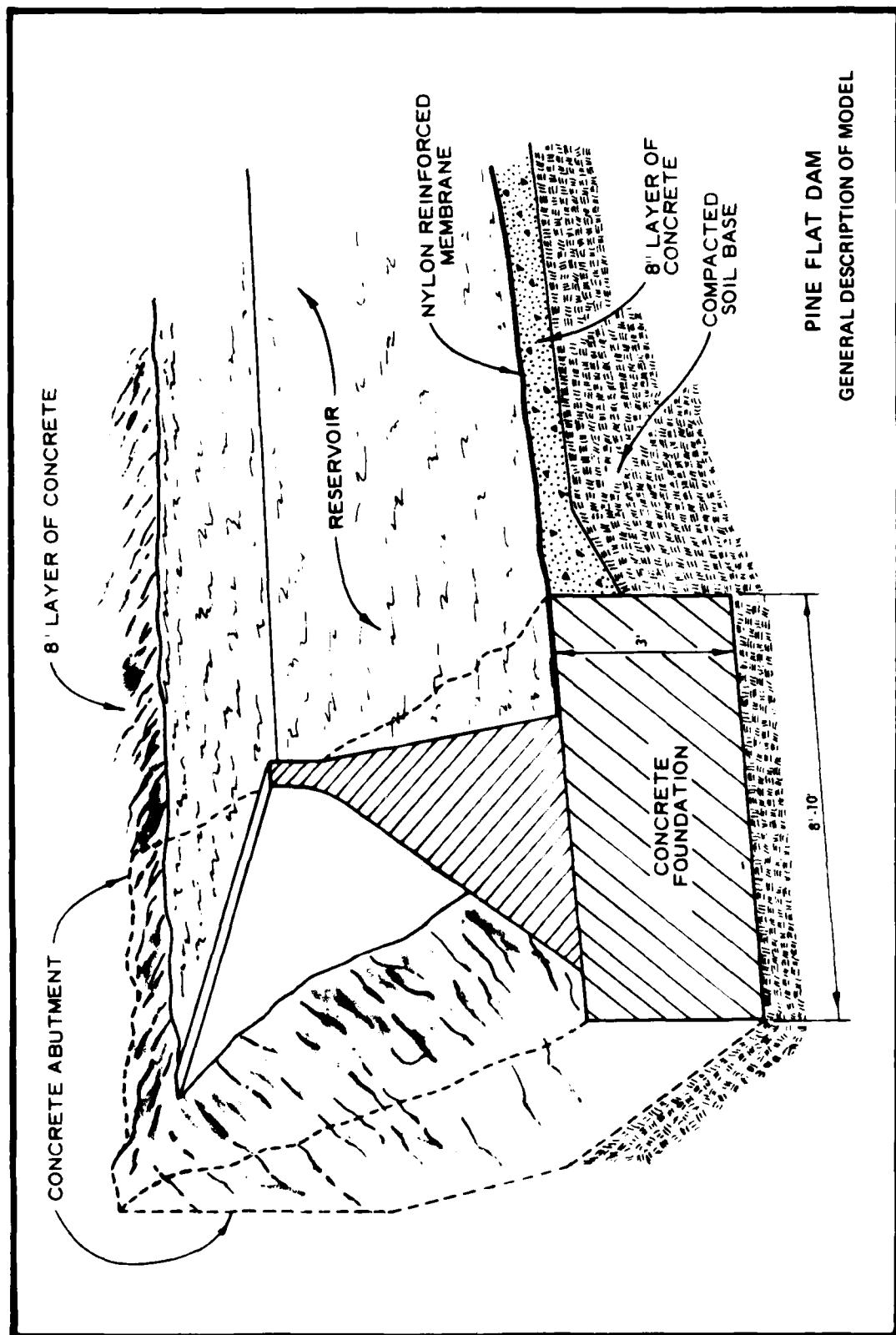
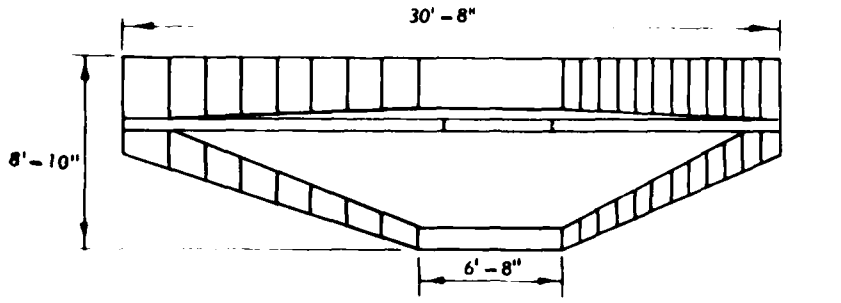
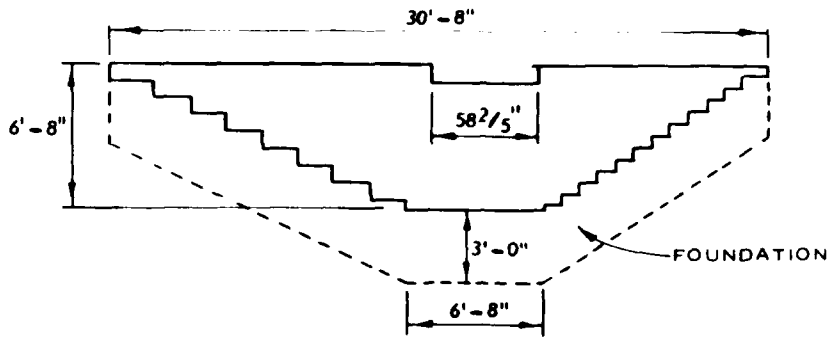

PLATE 2



TOP VIEW



PROFILE

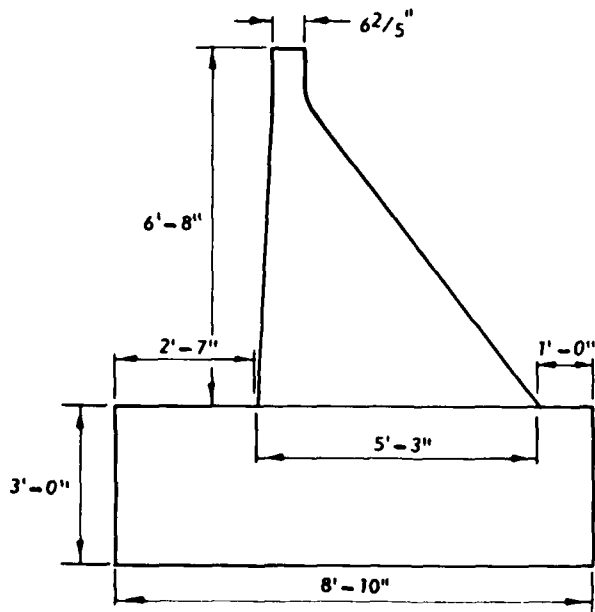

CROSS SECTION

**PINE FLAT DAM
TOP, PLAN, AND CROSS-SECTIONAL
VIEWS OF MODEL**

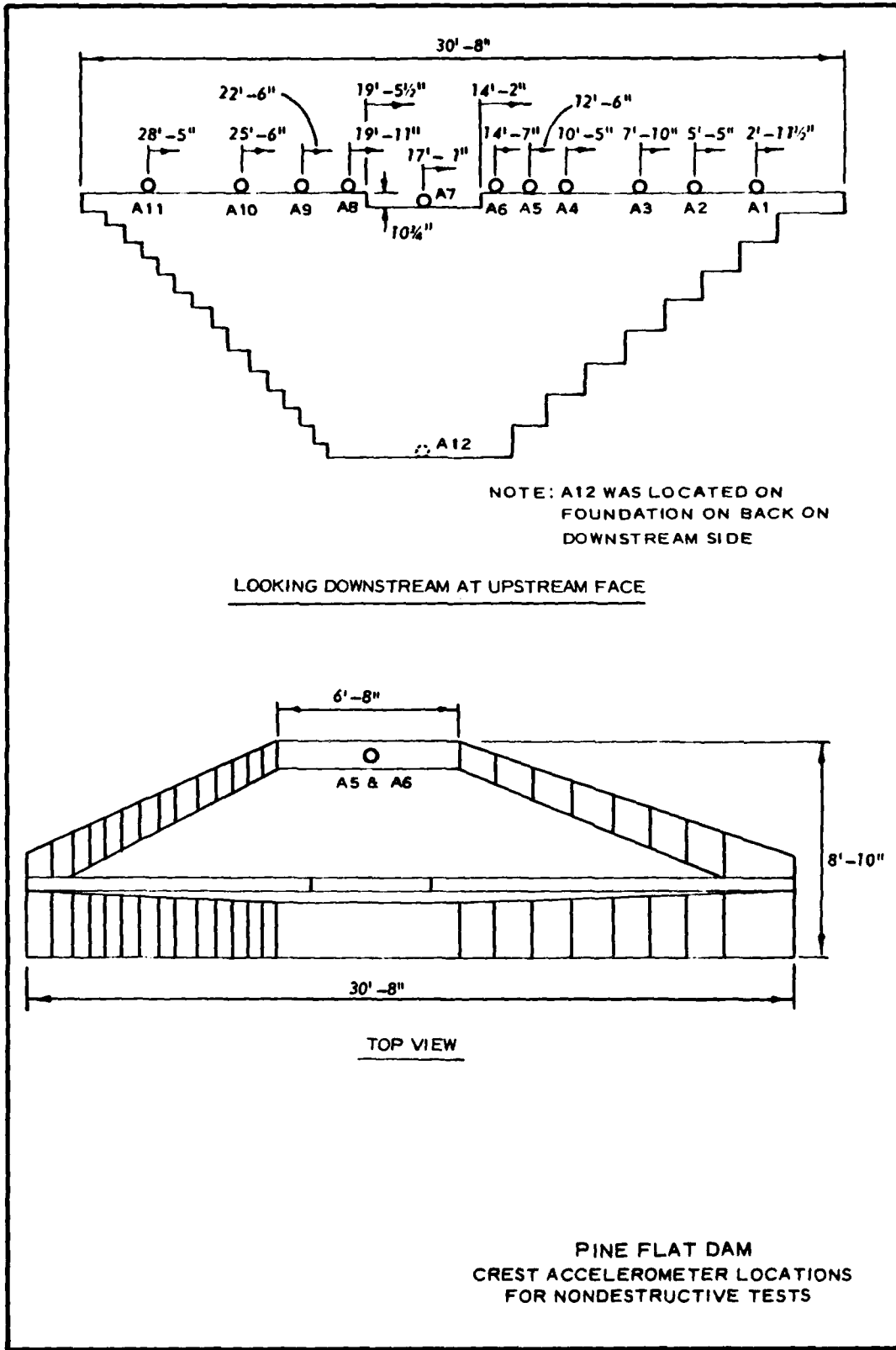
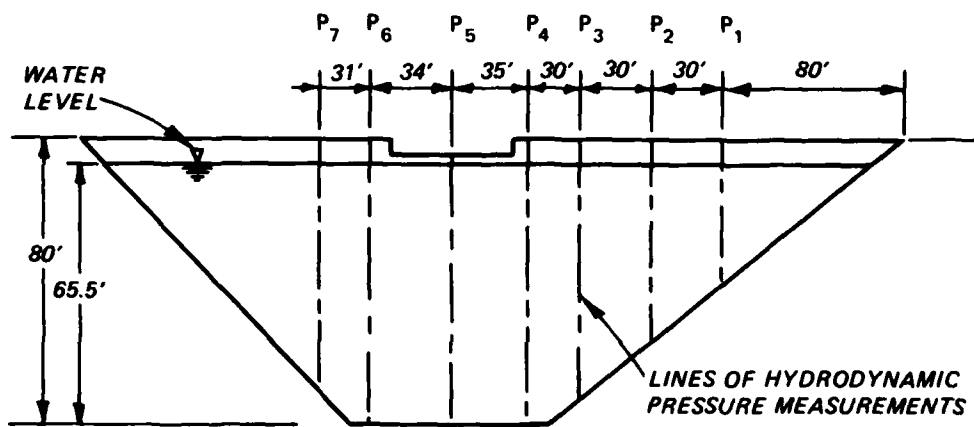

PLATE 4



LOOKING DOWNSTREAM AT
UPSTREAM FACE

PINE FLAT DAM
LOCATIONS OF VERTICAL LINES
FOR HYDRODYNAMIC PRESSURE
MEASUREMENTS

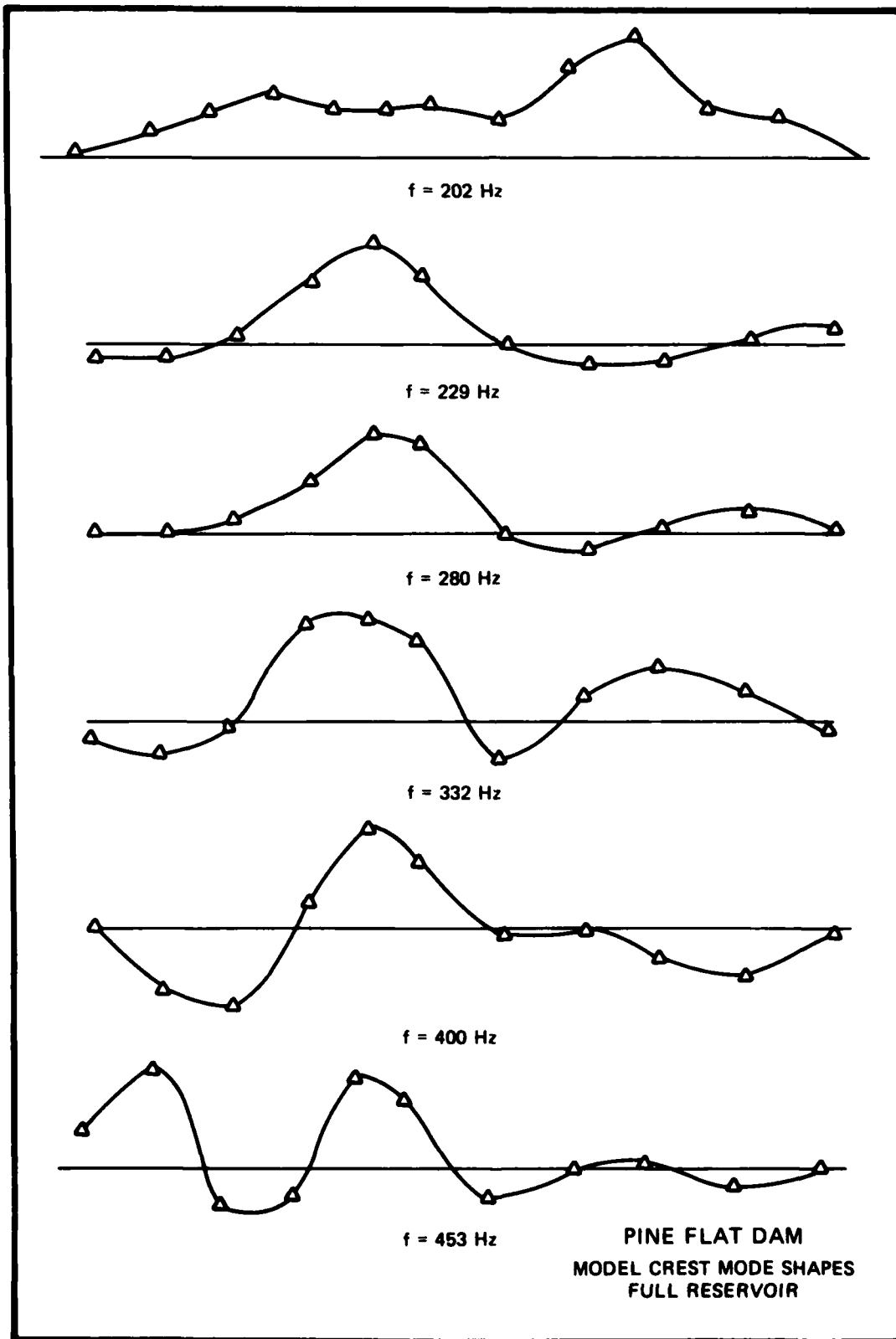
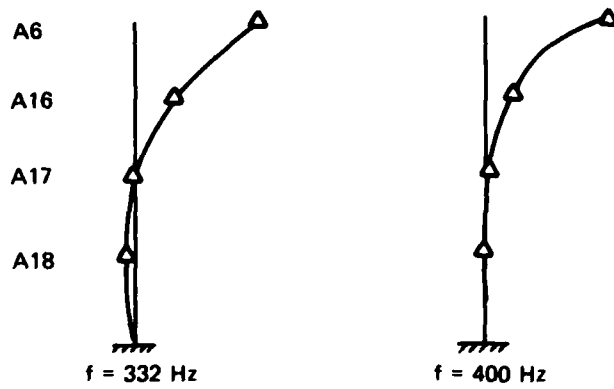
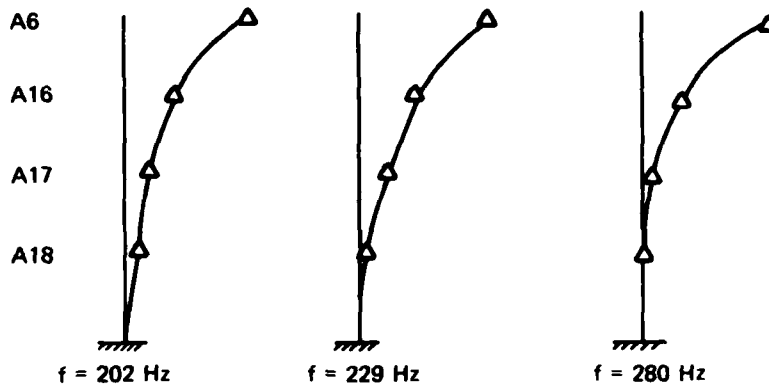
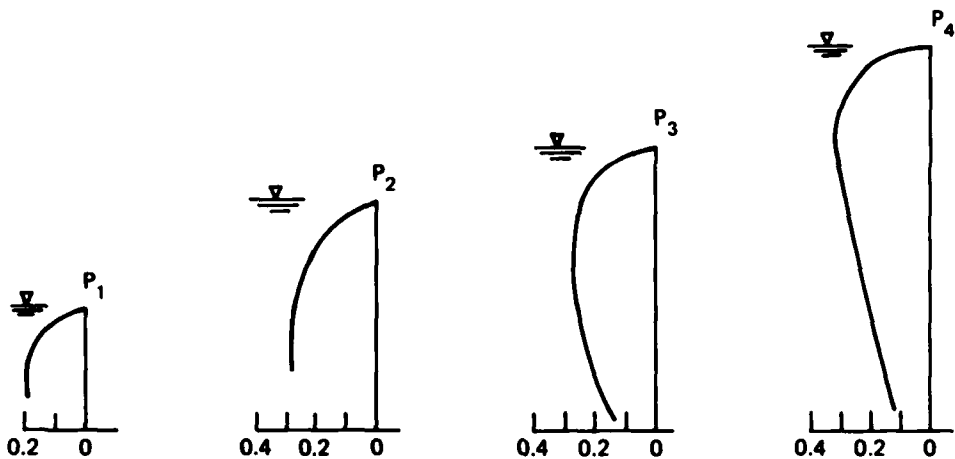

PLATE 6



PINE FLAT DAM
 MODEL CANTILEVER MODE SHAPES
 FULL RESERVOIR



PRESSURE, PSI

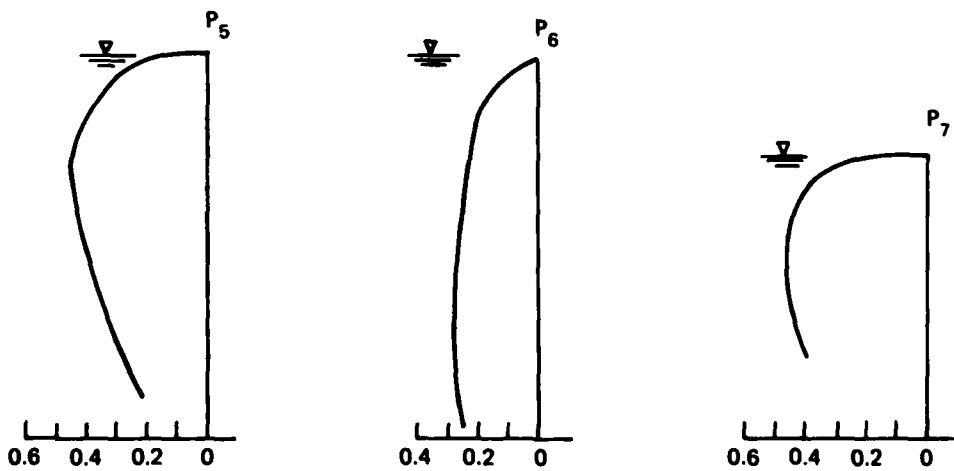

PRESSURE, PSI

PINE FLAT DAM
 HYDRODYNAMIC PRESSURE
 VARIATION WITH DEPTH
 $f = 227 \text{ Hz}$

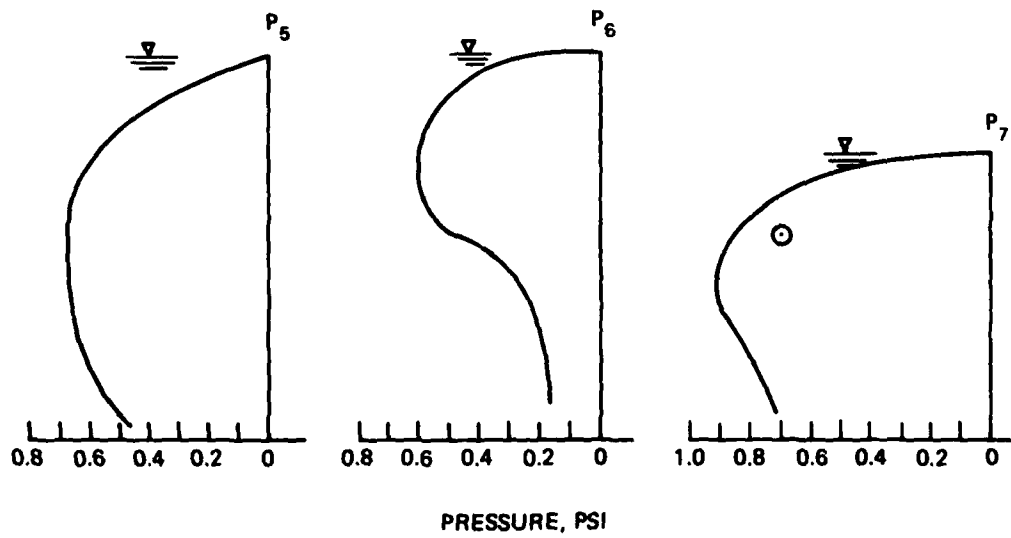
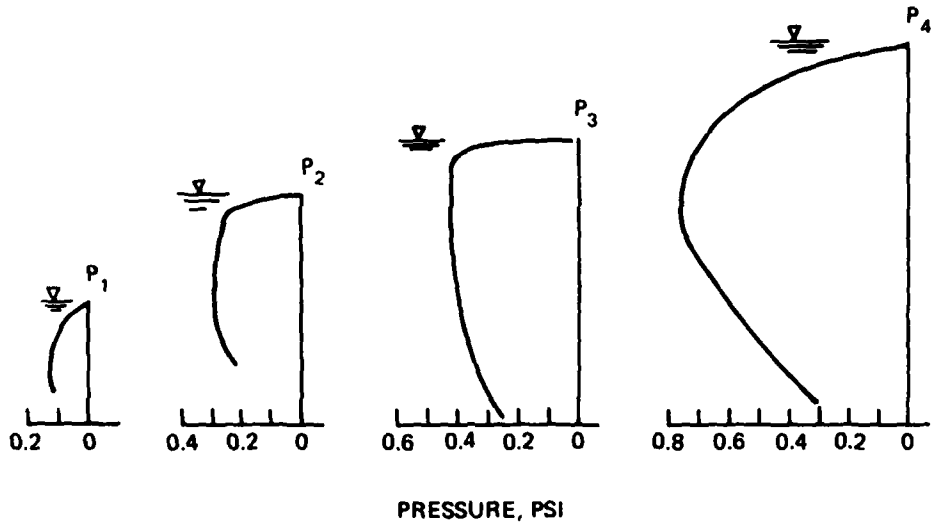

PINE FLAT DAM
 HYDRODYNAMIC PRESSURE
 VARIATION WITH DEPTH
 $f = 330 \text{ Hz}$

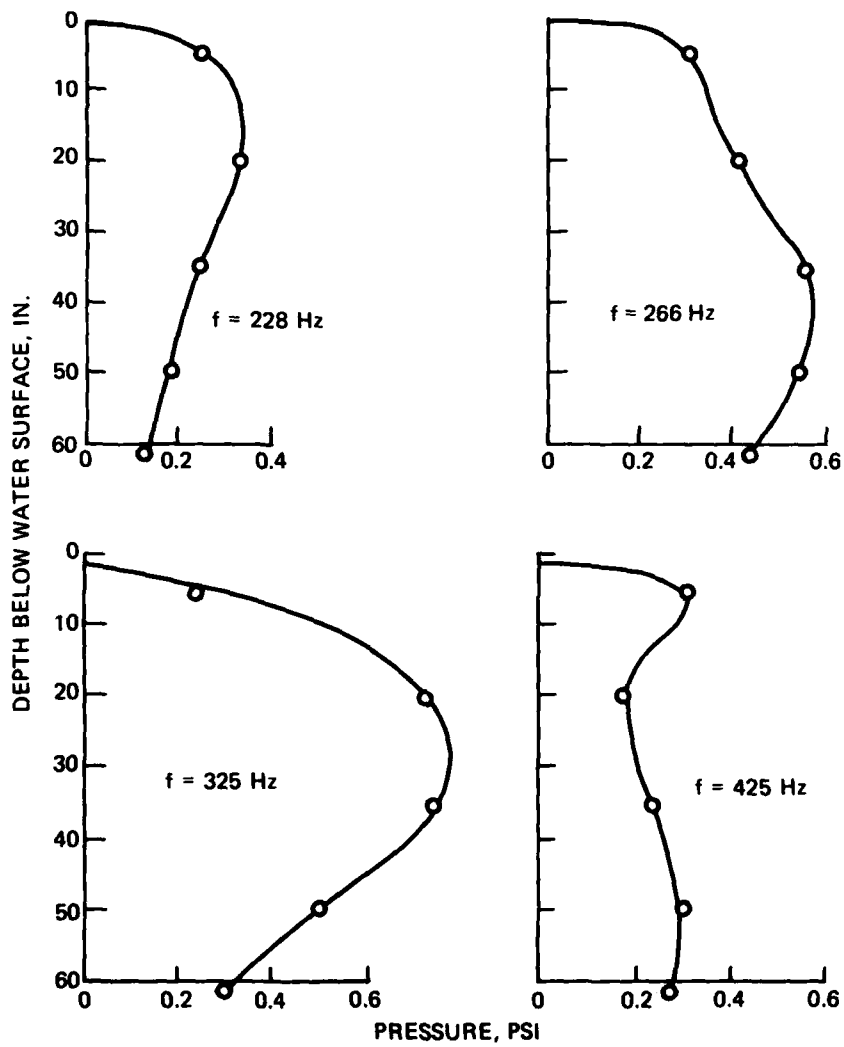

PINE FLAT DAM
 HYDRODYNAMIC PRESSURE
 VARIATION WITH DEPTH AT P₄
 FOR DIFFERENT EXCITATION
 FREQUENCIES

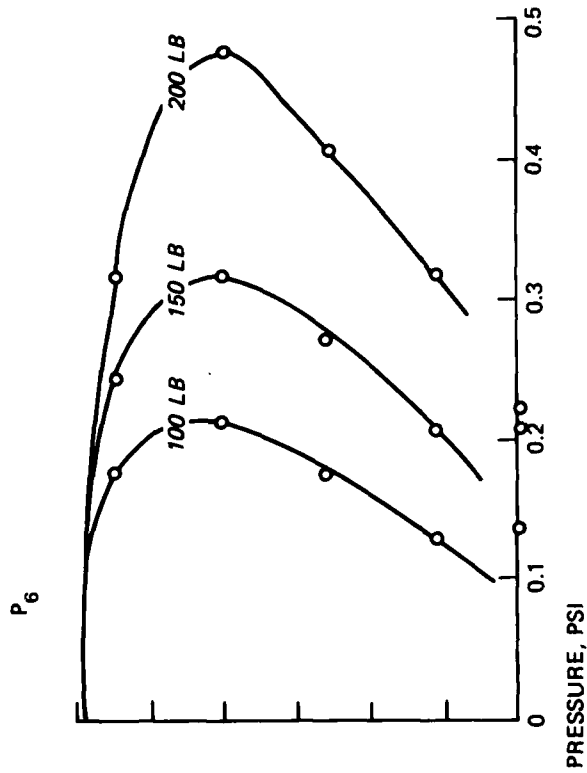
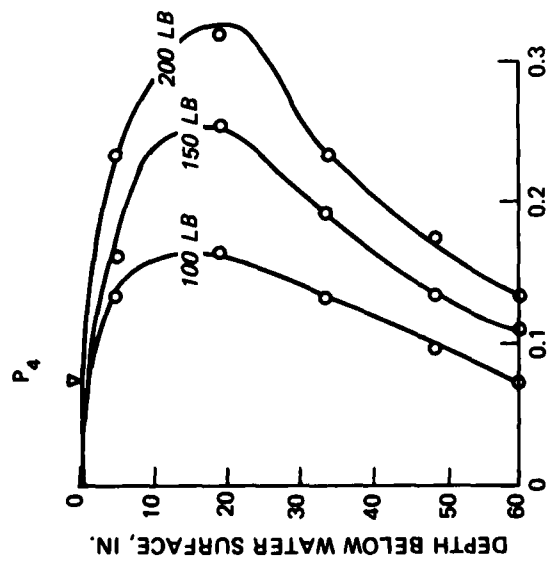

PINE FLAT DAM
 HYDRODYNAMIC PRESSURE
 VS DEPTH AT $f = 228$ Hz WITH
 EXCITATION FORCE VARYING

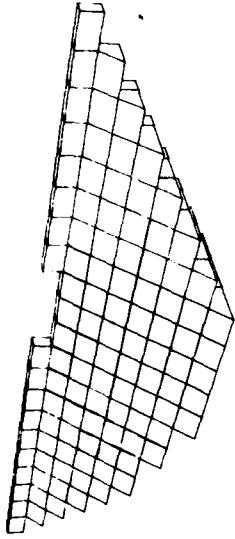

a. 3-D GRIDS

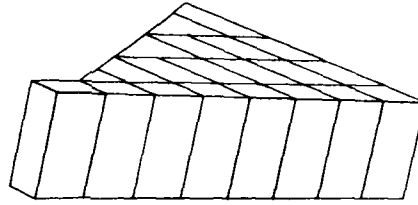

b. 2-D GRIDS

PINE FLAT DAM
MODEL FINITE ELEMENT GRIDS

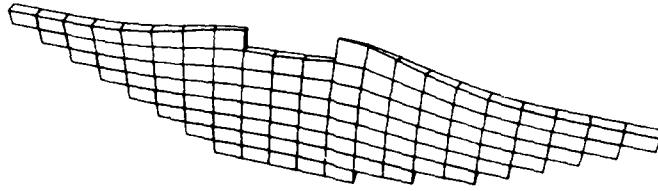

MODE 1, $f = 233.3$ Hz

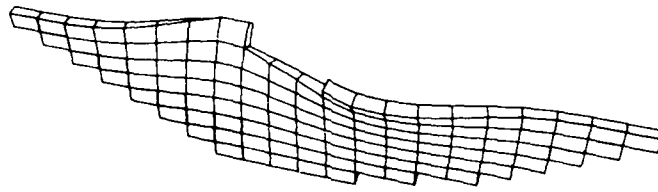

MODE 2, $f = 264.7$ Hz

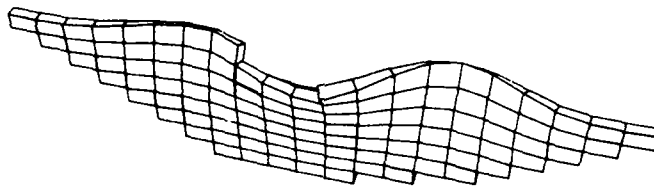

MODE 3, $f = 310.5$ Hz

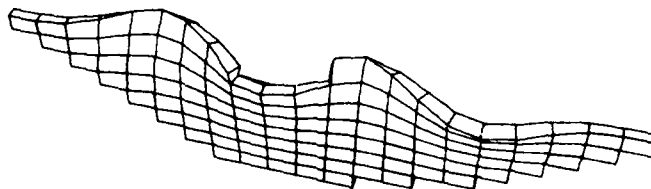

MODE 4, $f = 354.8$ Hz

PINE FLAT DAM
3-D MODE SHAPES FROM
FINITE ELEMENT ANALYSIS

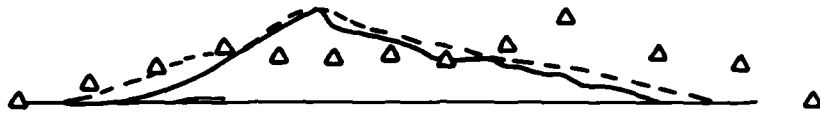

MODE 1

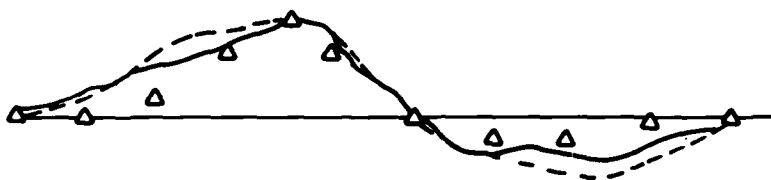

MODE 2

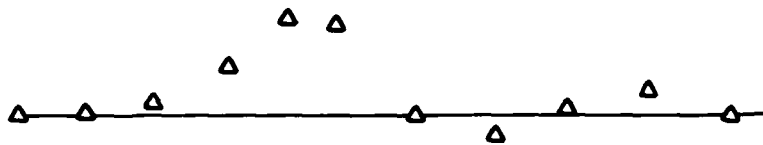

MODE 3

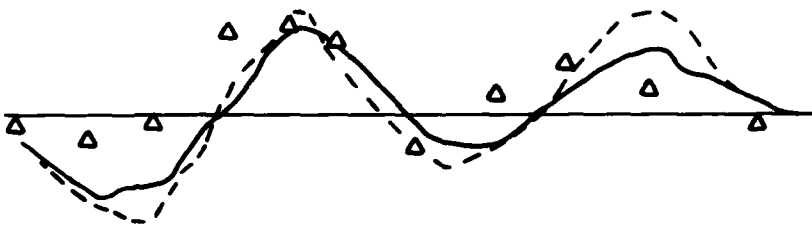

MODE 4

LEGEND
 △ MODEL DAM
 — PROTOTYPE SUMMER TESTS
 - - PROTOTYPE WINTER TESTS

PINE FLAT DAM
 COMPARISON OF MODEL AND
 PROTOTYPE CREST MODE SHAPES

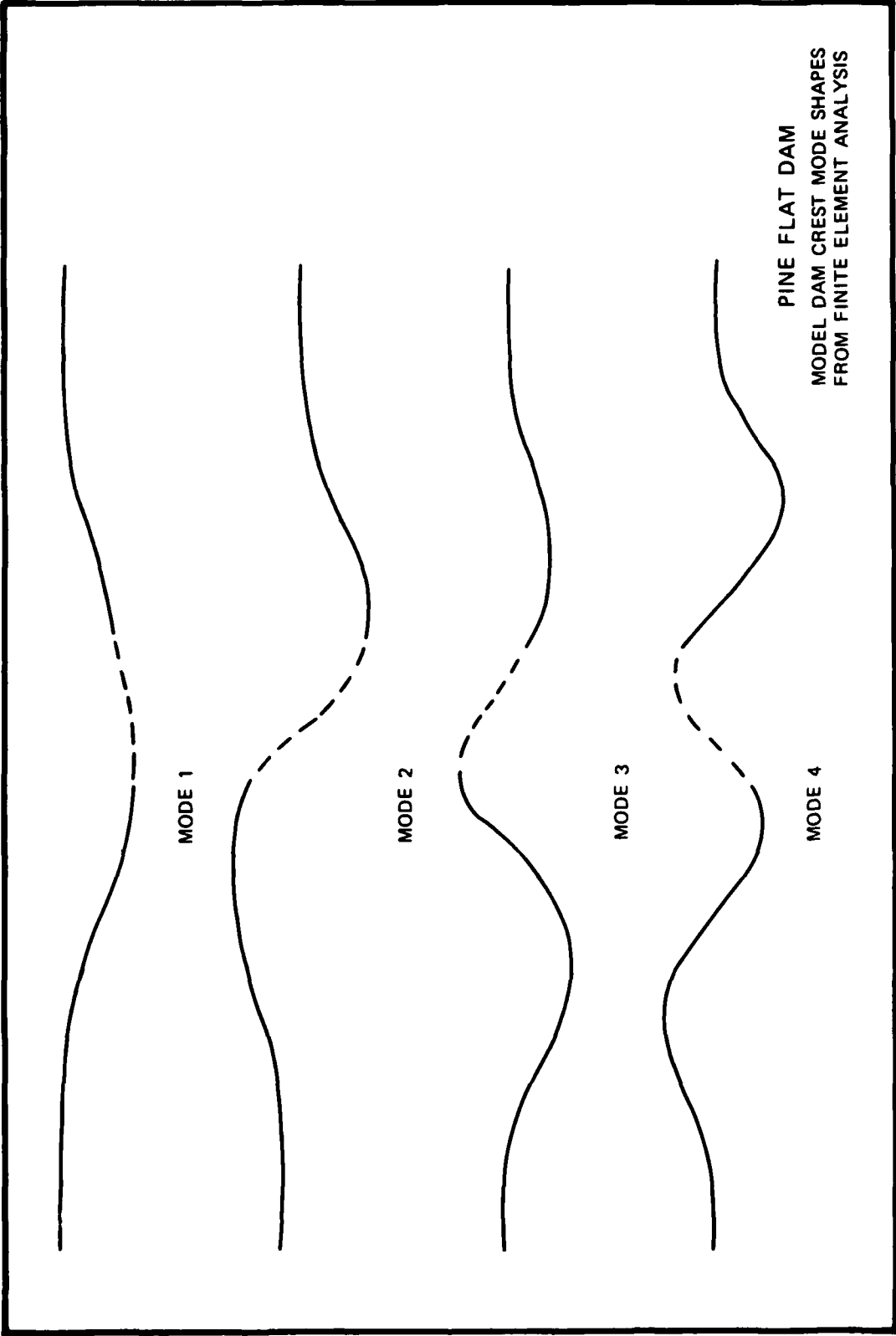

PINE FLAT DAM
MODEL DAM CREST MODE SHAPES
FROM FINITE ELEMENT ANALYSIS

APPENDIX A: MODEL SCALING RELATIONS

1. An accurate model for a structure subjected to seismic-type disturbances requires that inertia, gravity, and elastic forces be correctly reproduced in the model. Elastic forces or internal forces due to deformation and gravity forces cannot be simultaneously reproduced in a model. Discrepancies arise since the two forces scale differently in the model. In modeling the dynamic response of structures, different phenomena must be studied using different scaling conditions. For example, elastic forces must be scaled when structural deformation or cracking is studied. Scaling gravity forces become important when stability has to be modeled. Froude's condition requires that the ratio of the inertia forces to the gravity forces be constant in the model and prototype, and elastic forces are neglected. Cauchy's condition requires that the ratio of inertia forces to elastic forces be constant in the model and prototype, and gravitational effects are neglected. Since the two conditions are incompatible, the model designer must select one or the other based upon the phenomena to be studied. Borges and Perira (1970) present the two scaling conditions in more detail. In terms of physical quantities, the forces can be represented as follows:

$$\begin{aligned} \text{Inertia forces: } & \rho L^4 t^{-2} \\ \text{Gravity forces: } & \gamma L^3 \\ \text{Elastic forces: } & EL^2 \end{aligned} \tag{A1}$$

where:

ρ = mass density
 L = characteristic length
 t = characteristic time
 γ = specific weight
 E = material modulus

Cauchy's condition can be expressed as follows:

$$C = \frac{\rho L^4 t^{-2}}{E L^2} \quad \text{or} \quad \frac{V^2 \rho}{E} \quad (\text{A2})$$

Froude's condition is shown as follows:

$$F = \frac{\rho L^4 t^{-2}}{\gamma L^3} \quad \text{or} \quad \frac{V^2}{Lg} \quad (\text{A3})$$

In Equation A2, $V^2 \rho / E$ can be made constant for both model and prototype. However, if this is done, V^2 / Lg in Equation A3 cannot be made constant for both model and prototype unless the scale factor is unity or unless the quantity E / ρ scales as the length. Since this condition cannot be satisfied in most cases, a model cannot be fabricated to scale both elastic and gravity forces.

2. The similitude relation corresponding to the Cauchy condition can be expressed in terms of three scale factors. With the scale factors for length, elastic modulus, and mass density represented by S_L , S_e , and S_ρ , respectively, the similitude conditions for the design of the model and for model to prototype predictions can be expressed as:

<u>Physical Quantity</u>	<u>Symbol</u>	<u>Scaling Relation</u>
Length	L	$L_p = S_L L_m$
Material modulus	E	$E_p = S_e E_m$
Mass density	ρ	$\rho_p = S_\rho \rho_m$
Poisson's ratio	ν	$\nu_p = \nu_{m_2}$
Force	F	$F_p = S_e S_L F_m$
Time	t	$t_p = S_L S_\rho^{1/2} S_e^{-1/2} t_m$

(Continued)

<u>Physical Quantity</u>	<u>Symbol</u>	<u>Scaling Relation</u>
Acceleration	a	$a_p = A_L^{-1} S_E S_\rho^{-1} a_m$
Velocity	V	$V_p = S_E^{1/2} S_\rho^{-1/2} V_m$
Displacement	δ	$\delta_p = S_L \delta_m$
Frequency	f	$f_p = S_L^{-1} S_\rho^{-1/2} S_E^{1/2} f_m$

3. The first four conditions dictate the design requirements for the model; the next two conditions dictate the force function scaling; and the remaining conditions represent the prediction equations.

4. Cauchy's condition is ideally satisfied if $S_E = S_\rho = 1$; i.e., if the model and prototype have the same material properties. The scaling relations for the model dam, with $S_L = 60$ and $S_E = S_\rho = 1$, are:

$$L_p = 60L_m$$

$$E_p = E_m$$

$$\rho_p = \rho_m$$

$$v_p = v_m$$

$$F_p = (60)^2 F_m$$

$$t_p = 60t_m$$

$$a_p = a_m/60$$

$$V_p = V_m$$

$$\delta_p = 60\delta_m$$

$$f_p = f_m/60$$

In accordance with letter from DAEN-RDC, DAEN-ASI dated 22 July 1977, Subject: Facsimile Catalog Cards for Laboratory Technical Publications, a facsimile catalog card in Library of Congress MARC format is reproduced below.

Norman, C. Dean

Comparison of vibration test results for a model and prototype gravity dam / by C. Dean Norman, Harry E. Stone (Structures Laboratory, U.S. Army Engineer Waterways Experiment Station). -- Vicksburg, Miss. : The Station ; Springfield, Va. ; available from NTIS, 1981. 28 p. in various pagings, 15 p. of plates : ill. ; 27 cm. -- (Technical report / U.S. Army Engineer Waterways Experiment Station ; SL-81-7)

Cover title.

"October 1981."

Final report.

"Prepared for Office, Chief of Engineers, U.S. Army under Work Unit No. 31273."

Bibliography: p. 21.

1. Concrete dams. 2. Gravity dams. 3. Hydraulic models. 4. Vibration tests. I. Stone, Harry E. II. United States. Army. Corps of Engineers. Office of the Chief of Engineers. III. U.S. Army Engineer

Norman, C. Dean

Comparison of vibration test results for a model : ... 1981.
(Card 2)

Waterways Experiment Station. Structures Laboratory.
IV. Title V. Series: Technical report (U.S. Army
Engineer Waterways Experiment Station) ; SL-81-7.
TA7.W34 no.SL-81-7