

AD-A108 029

BOEING AEROSPACE CO HOUSTON TX SPACE DIV  
SNEAK CIRCUIT ANALYSIS OF F-4C FLIGHT CONTROL SYSTEM, (U)  
SEP 74 P F STOKES

F/G 17/7

F33657-74-C-0686

UNCLASSIFIED

D2-118545-1

NL

1 of 2

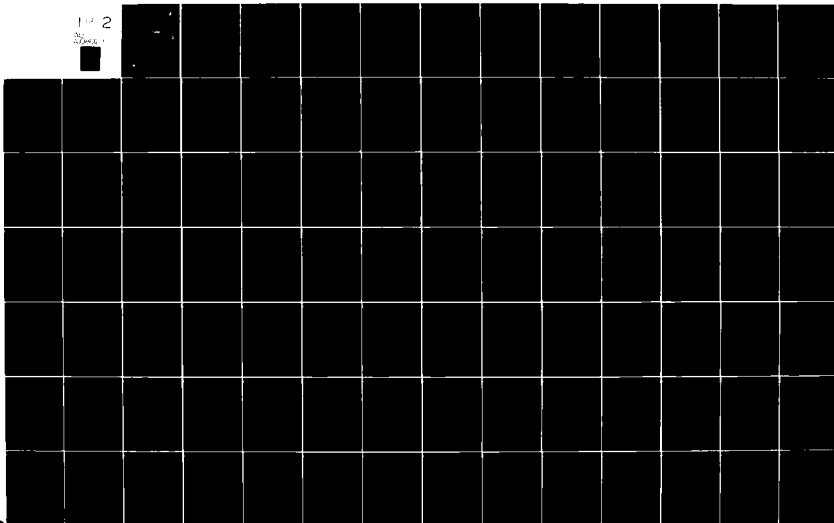

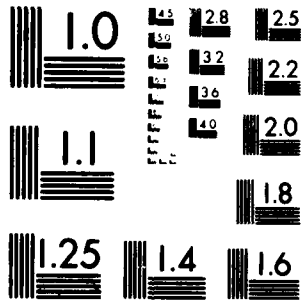

MICROCOPY RESOLUTION TEST CHART  
NATIONAL BUREAU OF STANDARDS 1963 A.

**LEVEL**

D2-118545-1

AD A108029

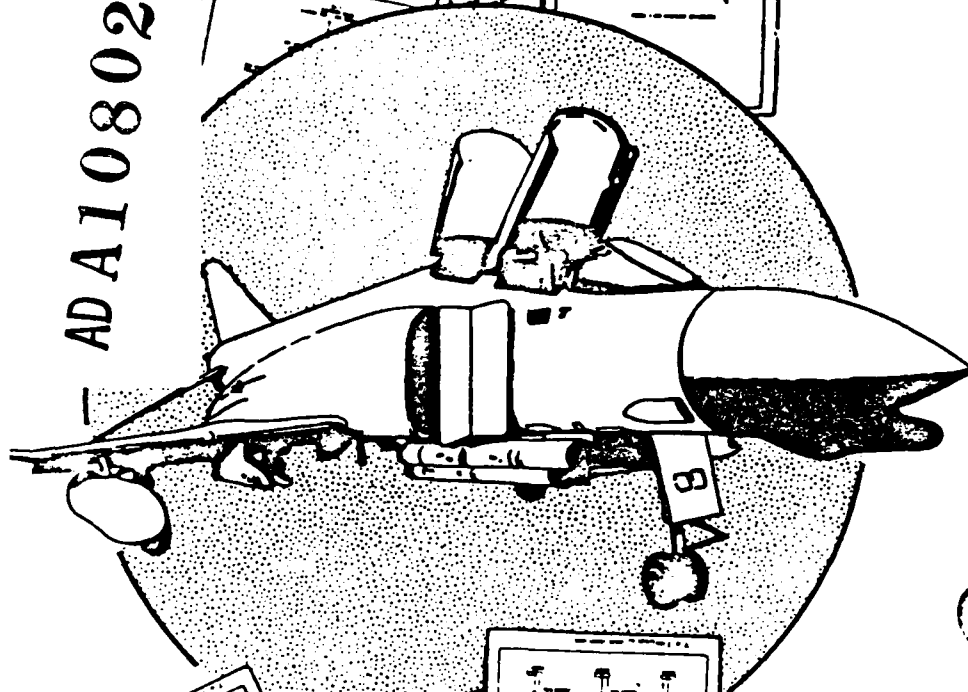

DTIC  
COLLECTED  
NOV 27 1981  
H D

# Sneak Circuit Analysis of F-4C Flight Control System

DUPLICATE COPY

DISTRIBUTION STATEMENT A  
Approved for public release;  
Distribution Unlimited

THE **BOEING** COMPANY

SEPTEMBER, 1974  
HOUSTON, TEXAS

3047 81 5 26 100

DOCUMENT NO. D2-118545-1

TITLE SNEAK CIRCUIT ANALYSIS OF F-4C FLIGHT CONTROL SYSTEM

MODEL NO. F-4C CONTRACT NO. F33657-74-C-0686

ORIGINATING ORGANIZATION (IF APPLICABLE)

SEPTEMBER 17, 1974

DATE OF RELEASE

Prepared by: Paul F. Stokes  
P. F. Stokes

Approved by: E. J. Hill  
E. J. Hill

Approved by: D. A. Heuer  
D. A. Heuer

ISSUE NO. ISSUED TO

THE BOEING COMPANY SPACE DIVISION, HOUSTON, TEXAS

DISTRIBUTION STATEMENT  
Approved for Release  
Distribution is unlimited

ABSTRACT

C. ✓ This report documents the results of a Sneak Circuit Analysis which was performed on the F-4C Flight Control System and describes how the analysis was performed. This analysis uncovered 4 sneak circuits and 16 drawing errors. Fourteen design concern reports were prepared describing possible weaknesses in the design and causes for failure of components. High failure-rate components in the Control Amplifier were analyzed to determine the effect each component failure has on the flight of the aircraft. This analysis has shown that Sneak Circuit Analysis can uncover problems which have existed over several years resulting in unscheduled maintenance but which have not been identified by extensive testing, troubleshooting, and other methods of analysis.

Submission For	✓
Approved	
Reviewed	
Per	
FL-182-2171	
on file	
A	

## TABLE OF CONTENTS

	ABSTRACT	ii
	TABLE OF CONTENTS	111
1.0	INTRODUCTION	1
2.0	SCOPE	2
3.0	INPUT DATA/COMPUTER OPERATIONS	3
4.0	ANALYSIS	4
4.1	CHANGE ANALYSIS	4
5.0	RESULTS	5
5.1	RESULTS - CHANGE ANALYSIS	5
6.0	CONCLUSIONS	6
7.0	RECOMMENDATIONS	7
APPENDIX A	SNEAK CIRCUIT REPORTS	A1
APPENDIX B	DESIGN CONCERN REPORTS	B1
APPENDIX C	DRAWING ERROR REPORTS	C1
APPENDIX D	MATRIX - COMPONENT FAILURE VS. AIRCRAFT EFFECT	D1
APPENDIX E	INVESTIGATION REPORTS	E1
APPENDIX F	DATA BASELINE	F1

1.0 INTRODUCTION

This report documents the results of the sneak circuit analysis performed on the F-4C Automatic Flight Control System. This work was done by Boeing Aerospace Company, Houston, Texas, under contract F33657-74-C-0686 with AFSC Aeronautical Systems Division Avionics Program Office at Wright-Patterson Air Force Base, Ohio. The purpose of this report is: (1) To describe the general procedures used to detect sneak circuits, (2) To document the accumulated results of the sneak circuit analysis, and (3) To describe the effect known high failure-rate components in the Control Amplifier have on the aircraft when these components fail.

2.0 SCOPE

The sneak circuit analysis was performed on the Automatic Flight Control System, Stability Augmentation System, Aileron-Rudder Interconnect System, Lateral Control System, Stabilator Manual Control and Feel Trim System, and the Rudder Control and Trim System as defined in T.O. 1F-4C-2-4 and T.O. 1F-4C-2-16. High failure-rate components in the Control Amplifier which were identified by the Air Force on data received were analyzed in both the normal and failed modes.

### 3.0 INPUT DATA/COMPUTER OPERATIONS

The analysis was based on Air Force Technical Manuals (T.O.'s) covering all of the systems listed in paragraph 2.0 and G.E. schematics of the Control Amplifier C-6563A/ASA-32H. This data was provided by the Air Force. High failure components (capacitors, diodes, and one resistor) in the Control Amplifier had been identified in the data received for analysis to determine the effect on the aircraft for each component failure.

The Automated Sneak Program (ASP) was used on the F-4C AFCS to aid in the sneak circuit analysis. The ASP produces reports that are designed to be used in plotting the network trees required for the analysis.

The detailed schematics and wiring diagrams for the F-4C AFCS were coded for input to the computer. This data was keypunched and compiled for subsequent processing. The Automated Sneak Program then searched through the coded wiring data, connecting the segments starting with power sources and ending either at ground points or at other power sources. This path tracing series of programs resulted in circuits separated into nodal sets. The F-4C AFCS output data contained 1141 paths in 90 nodal sets.

#### 4.0 ANALYSIS

Analysis of the F-4C circuitry for evidence of sneak circuits was conducted to identify four types of sneak circuit conditions: (1) A sneak path that causes current or energy to flow along an unexpected route, (2) Sneak timing that causes current or energy to flow or inhibit a function at an unexpected time, (3) A sneak indication that causes an ambiguous or false display of system operating conditions, and (4) A sneak label that causes incorrect stimuli to be initiated.

Also, this circuitry was analyzed for the following design concern conditions (1) Unsuppressed relays, (2) Excess circuitry and unnecessary components, and (3) Possible single failure points.

Following the sneak circuit analysis, the network trees were reanalyzed with each component, previously identified as a high failure item, failed in a particular mode to determine the effect each failure has on the flight of the aircraft.

#### 4.1 CHANGE ANALYSIS

Following the completion of the sneak circuit analysis, any modifications to the circuitry can be evaluated by first incorporating the changes into the affected nodal sets, then analyzing the new circuit using sneak circuit techniques.

## 5.0 RESULTS

The sneak circuit analysis on the F-4C AFCS resulted in 4 Sneak Circuit Reports, 14 Design Concern Reports and 14 Drawing Error Reports. These reports are included in Appendixes A, B, and C respectively. Appendix D contains a matrix which summarizes the effect each high failure item has on the aircraft when that item fails. This matrix also provides a cross reference to the investigation reports of Appendix E where detailed information concerning the effect each of these failures has on the aircraft is found. Drawings are provided to aid in the explanation of these effects. Appendix F lists the drawings used to conduct this analysis.

During the investigation of the high failure components, possible reasons for some of the failures were discovered. These possible reasons are provided in Design Concern Reports F-4C-7 through F-4C-14.

## 5.1 RESULTS - CHANGE ANALYSIS

Two proposed modifications to the F-4C AFCS circuitry were analyzed and found to be free of any sneak circuits. Two Drawing Error Reports were prepared during this effort and are included in Appendix C.

6.0 CONCLUSIONS

The following conclusions have been drawn from the analysis:

- A. The sneak circuits found during this analysis show that potential system problems exist even after extensive testing, long periods of operation, and other methods of analysis.
- B. The investigation of the high failure components shows that each failure results in the loss of all or part of the AFCS and may result in an aircraft safety problem.
- C. The investigation of the high failure components shows that component selection (type, working voltage, etc.) and the module sealing process contribute to the high failure rate of these components.
- D. The drawing errors found during this analysis make the AFCS theory of operation difficult to understand as well as providing conflicting information to maintenance technicians.
- E. An effective analysis with cost effective results can be performed on Air Force Systems which have been operational for a number of years.
- F. There are probably other systems on the F-4 and other operational aircraft which are good candidates for sneak circuit and component failure analysis as was done on the F-4C Flight Control System.

7.0 RECOMMENDATIONS

The analysis has resulted in the following recommendations:

- A. Incorporate the changes recommended in the sneak circuit reports where appropriate.
- B. Replace all nonhermetically sealed tantalum capacitors with hermetically sealed devices.
- C. Assure that the rated working voltage of each capacitor is not exceeded during normal circuit operation.
- D. Review the module sealing process in T.O. 5A3-50-3 to assure that capacitor damage does not occur when a vacuum is drawn on the module.
- E. Review the method used to supply voltage to the Control Amplifier to assure that transients generated by switching to another generator are not reflected in the AFCS.
- F. Correct the errors identified in the input data.
- G. Review the F-4 aircraft for other systems on which a cost effective sneak circuit analysis can be performed.

D2-118545-1

APPENDIX A  
SNEAK CIRCUIT REPORTS

## SNEAK CIRCUIT REPORT F-4C-1

TITLE Sneak Path in the Automatic Flight Control System Feel Trim Actuator Circuitry

DATE 7-19-74

ENGINEER Robert Clardy

*Mr. Robert Clardy*

## REFERENCES

T.O. 1F-4C-2-4 Change 8, February 15, 1974  
 T.O. 1F-4C-2-16 Change 6, March 1, 1974  
 T.O. 1F-4C-2-23 Change 13, March 15, 1974

## MODULE/EQUIPMENT

AFCS/22-Z732

## EXPLANATION

This sneak circuit report is based upon the fact that when two or three relays are connected in series, one or more of them could be energized, depending on their respective pick-up voltages. The probability of this sneak circuit occurring increases if the Autopilot Trim Relays (K727 and K733) in ref. des. 22-Z732 are diode suppressed since current will flow through the diode thus effectively removing the series impedance of these coils from the circuit.

When the Stabilator Feel Trim Actuator Motor reaches its retract limit, the Nose Up Retract Limit Switch in ref. des. 22-B708 opens as shown in figure 1. If the FWD Trim Switch (22-S245) in ref. des. 65-MT223 or the AFT Trim Switch (22-S350) in ref. des. 22-AR3M20 is pushed to the UP position when either control stick is pulled back, the Trim Nose Up Force Link Switch (22-S720) is closed and the sneak path shown in figure 1 is established. Current will flow only when AFCS is disengaged. Current flows through the Manual Trim-Nose Up Relay (K726) in ref. des. 22-Z732 and through the Autopilot Trim Nose Up Relay (K733) in ref. des. 22-Z732. It then flows through the Force Link Switch and the Manual Trim Nose Up (K726) and Nose Down (K728) relay contacts. Current can then flow to ground by a number of paths depending on switch positions and relay contact closures discussed below. It is possible that relay K726 could be energized, causing relay chatter.

As shown in figure 2, a similar sneak path results when the Stabilator Feel Trim Actuator Motor reaches its extend limit and the Nose Down Extend Limit Switch in ref. des. 22-B708 opens. If a trim switch is then pushed to the Down position when either control stick is pushed forward, the Nose Down Force Link Switch (22-S719) is closed, current will flow through the Manual Trim-Nose Down Relay (K728) in ref. des. 22-Z732 and the Autopilot Trim-Nose Down Relay (K727) in ref. des. 22-Z732. Current could then flow to ground by the paths described below:

- Path A. As shown in Figure 3, if one of the 5 pound Warning Light Force Link Switches (22-S721 and 22-S722) is closed, power could be inadvertently fed to the Caution Lights Relay (K320) in ref. des. 52-Z327 which will turn on the A/P Pitch Trim Indicator, giving a false indication.
- Path B. If the Pitch Fade Relay (K20A - not shown) in ref. des. 65-AR305 has been energized so that relay contacts 2 and 7 in Figure 3 are closed, or if neither K20A nor the Pitch Force Switch Relay (K5A) in ref. des. 65-AR305 has been energized, a path will be established to the Altitude Switch (S103) in ref. des. 65-Z208. If it is depressed, it will activate its holding coil and the Altitude Engage Relay (K6A) in ref. des. 65-AR305. This will close the K6A relay contacts, allowing current to flow to the Pitch Sync Clutch in ref. des. 65-AR305A13 and to the Altitude Relay (K8A) in ref. des. 65-AR305. This will enable the Altitude Hold Circuitry even though AFCS is disengaged.

The following paths to ground all require that the Pitch Force Switch Relay (K5A) in ref. des. 65-AR305 is not energized by the FWD or AFT Pitch Force Switches (S202).

- Path C. As shown in figure 4, power can flow to the Parallel Pitch Shutoff Valve in ref. des. 65-U716 and to the Pitch Engage Relays (K3G and K3C) in ref. des. 65-AR305. This could cause the Pitch Channel of AFCS to be enabled even though AFCS is disengaged.
- Path D. If the Stability Augmentation Yaw (S104 - not shown) and Roll (S105 - not shown) switches in the Engaging Controller are closed, power is fed to the YAW (K36A) and Roll (K35A) Damper Engage Relays in ref. des. 65-AR305. When both of these are energized, current can flow through their contacts as shown in Figure 5, to the Roll Engage Relays (K3H and K3B) in ref. des. 65-AR305. This could cause the Roll Channel of AFCS to be enabled even though AFCS is disengaged.
- Path E. As shown in figure 5, if the FWD or AFT Pitch Force Switch (S202) in ref. des. 65-MT223 is thrown, the Pitch Force Relay (K5A) may be energized. If it energizes, it would cause relay chatter since its contacts in figure 3 are between it and the power source.
- Path F. If the Pitch Fade Relay (K20A) in ref. des. 65-AR305 is energized power is fed, as shown in Figure 5, to the Altitude Fade Relay (K27A) in ref. des. 65-AR305 and to the Pitch Sync Brake in ref. des. 65-AR305A13.
- Path G. As shown in figure 5, if the Pitch Fade Relay (K20A) is not energized, power is fed to the Altitude Engage Clutch in ref. des. 71-Z311.

#### POTENTIAL IMPACT

The Altitude Hold Circuitry and Roll and Pitch Channels of the Autopilot may be powered while AFCS is disengaged. There may be damage to AFCS relays due to relay chatter.

#### RECOMMENDATION

Add a diode in the location shown in Figures 1 and 2.

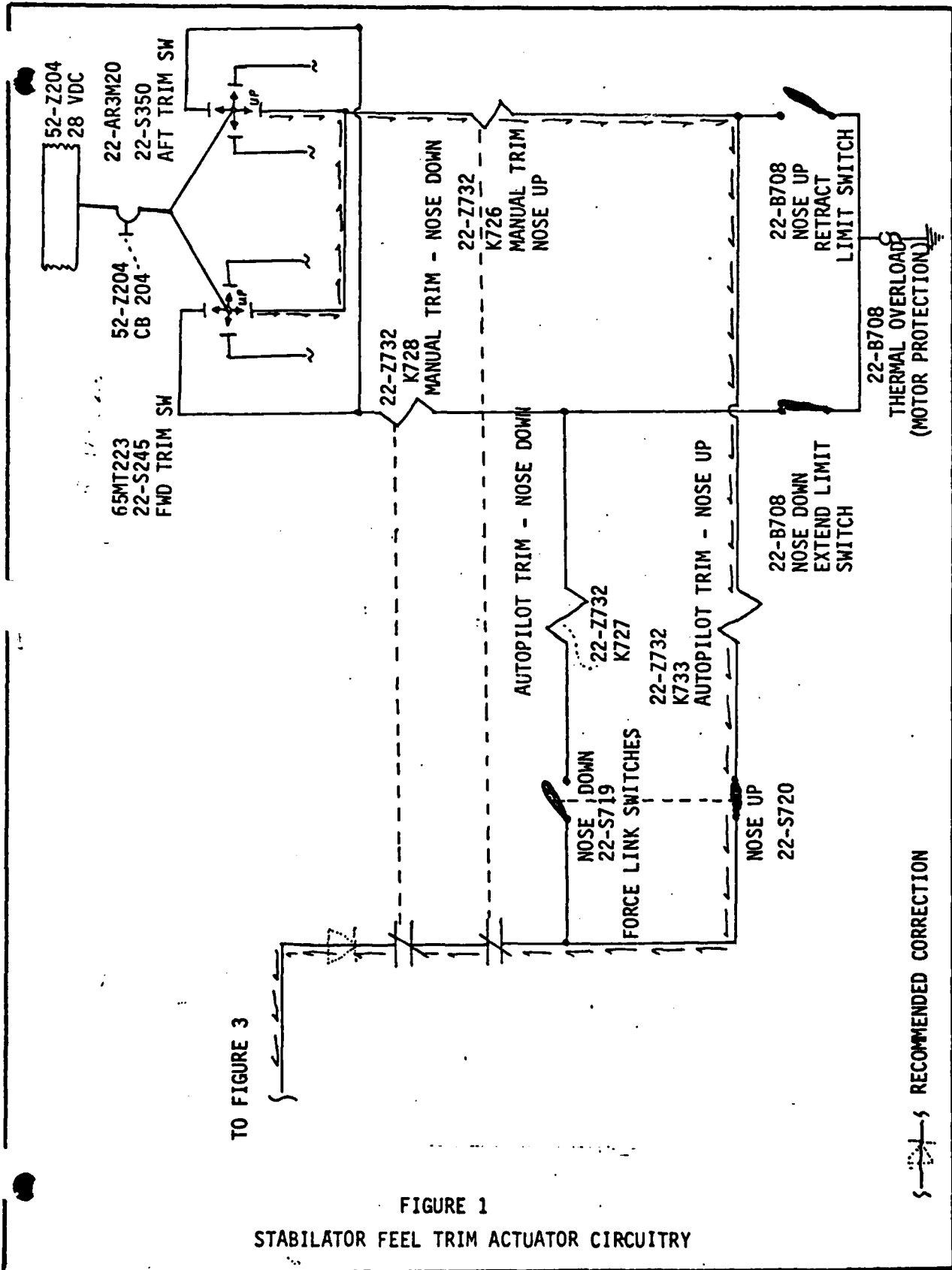
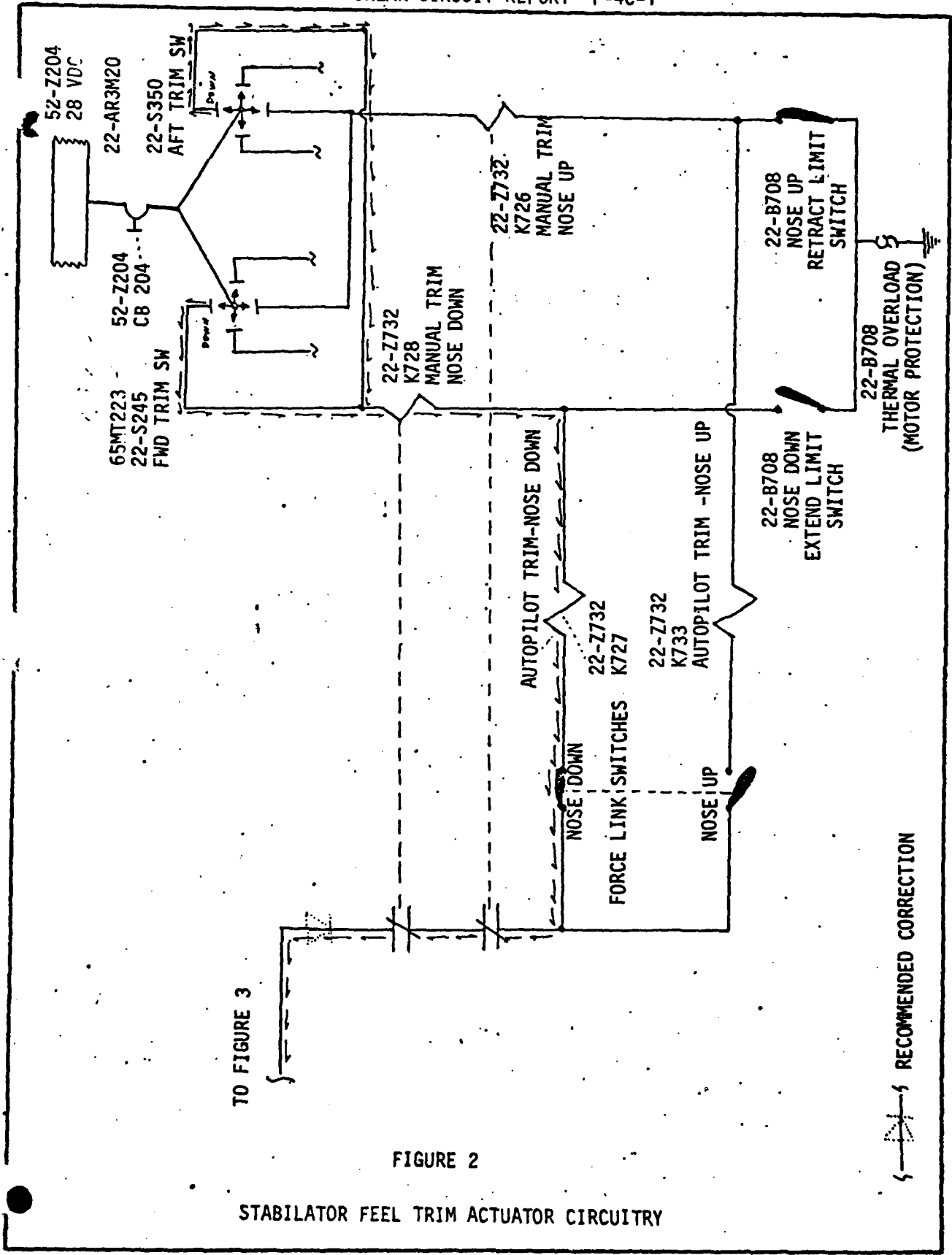

FIGURE 1  
 STABILATOR FEEL TRIM ACTUATOR CIRCUITRY



TO FIGURE 3

FIGURE 2

STABILATOR FEEL TRIM ACTUATOR CIRCUITRY

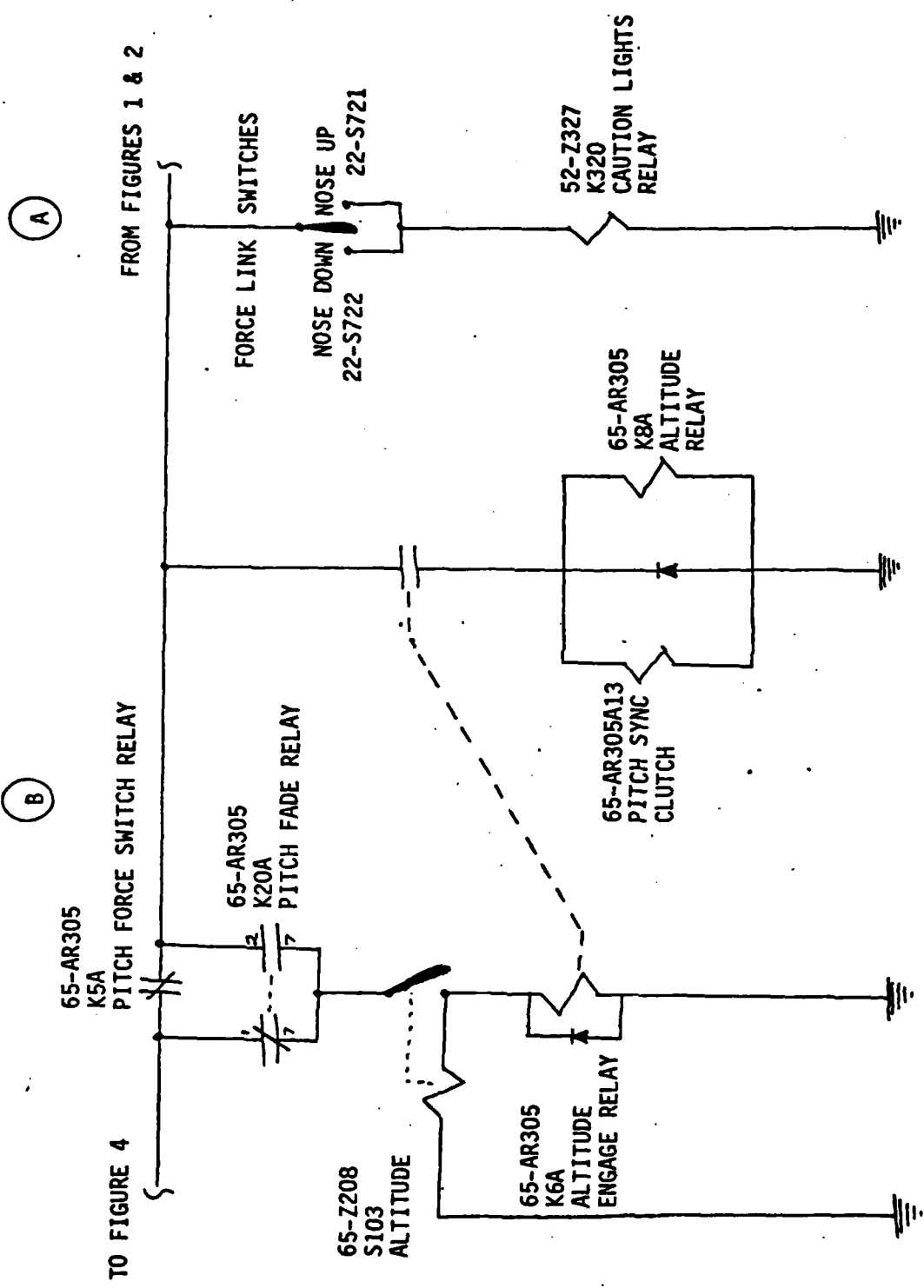

FIGURE 3  
 AFCS RELAY SWITCHING

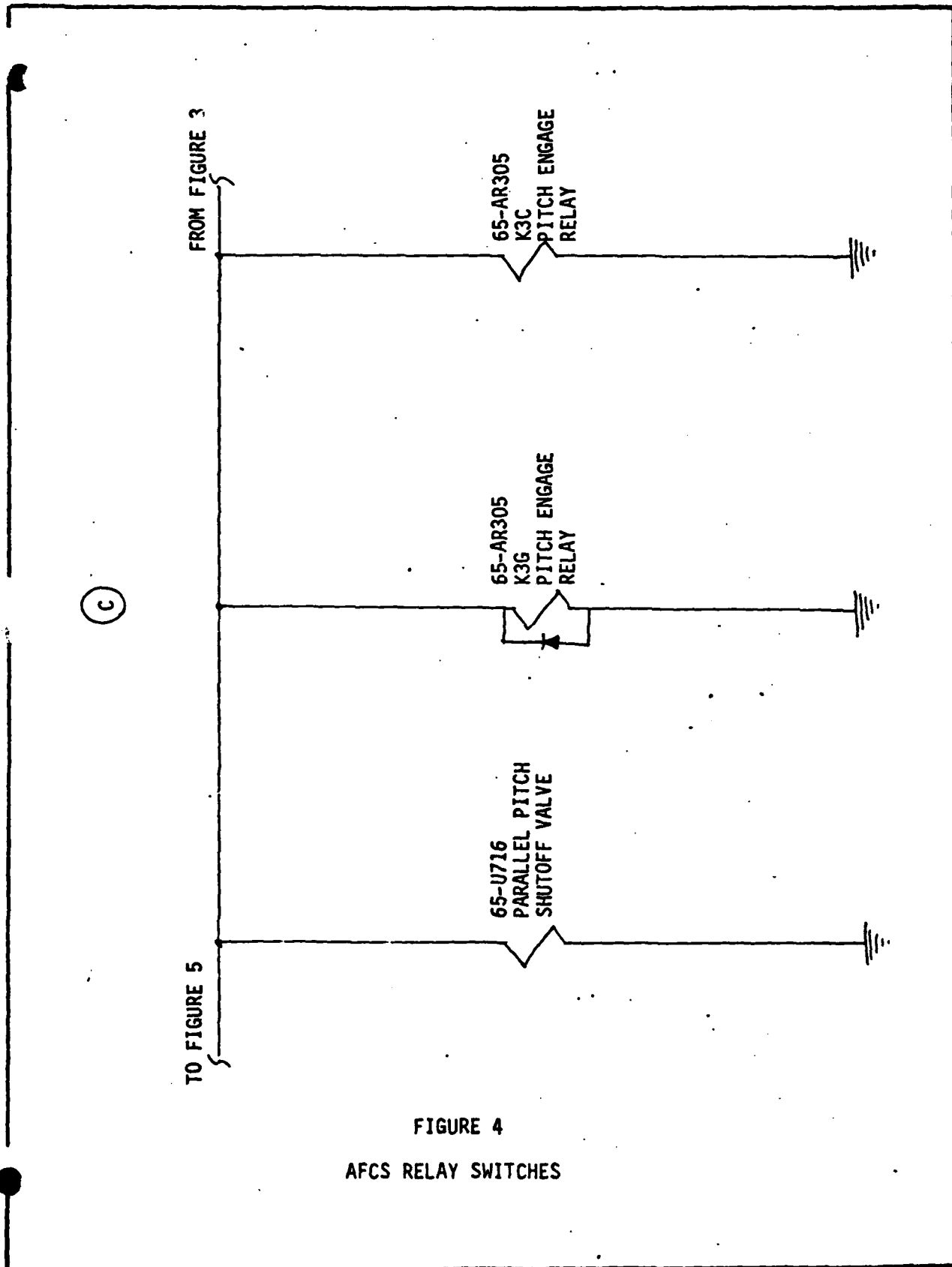

FIGURE 4  
AFCS RELAY SWITCHES

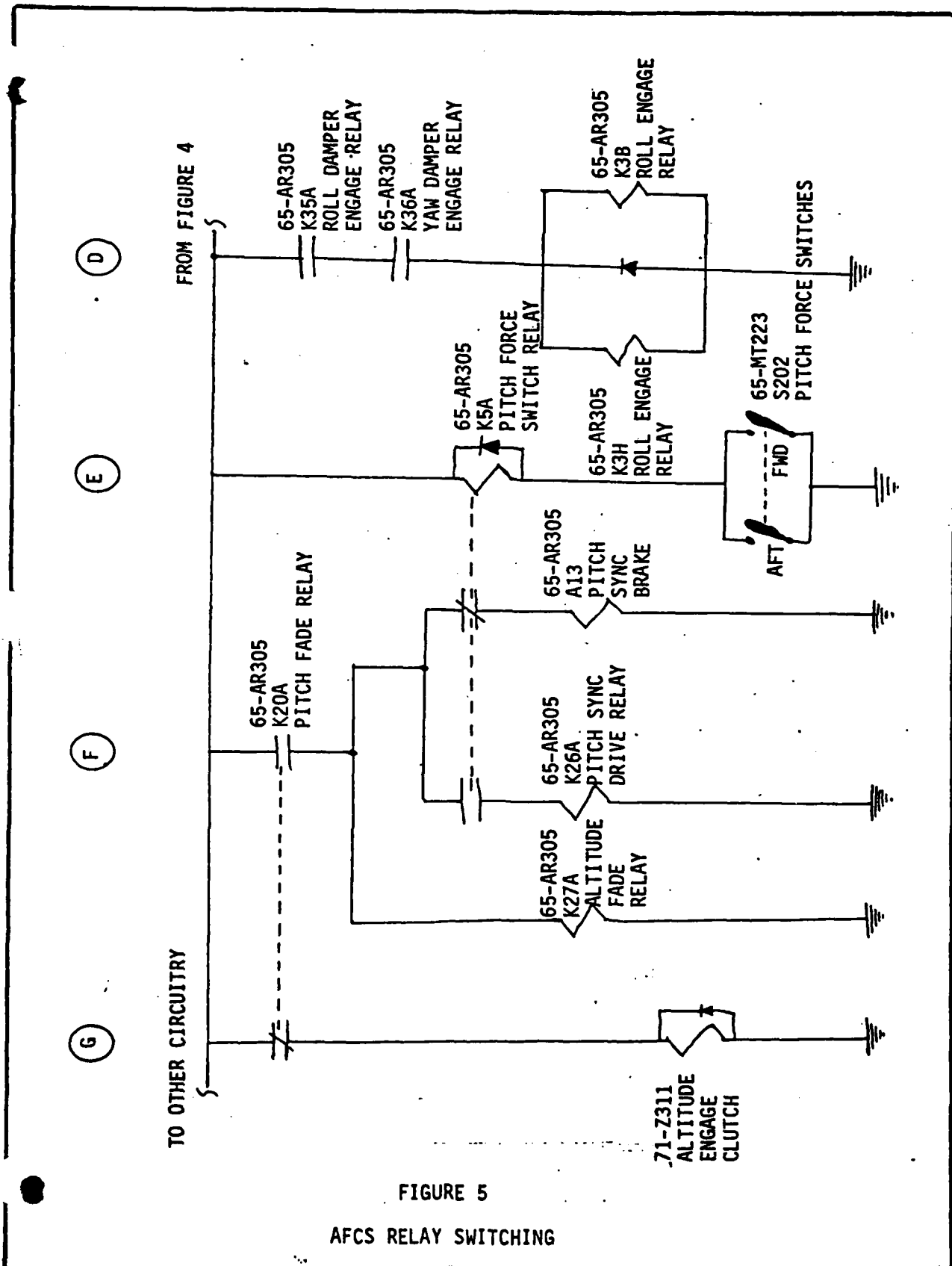

FIGURE 5  
AFCS RELAY SWITCHING

## SNEAK CIRCUIT REPORT F-4C-2R1 PAGE 1 OF 2

TITLE Sneak Path Between Pitch and Roll Stability  
Augmentation

DATE 7/18/74

ENGINEER R. Clardy

*Robert Clardy*

## REFERENCES

Schematic, Electrical System AN/ASA-32M Control Circuits Dwg. 281E402, Revision A.

## MODULE/EQUIPMENT

AFCS/65-AR305

## EXPLANATION

When the Pitch (S101), YAW (S104), and Roll (S105) Stability Augmentation Switches in ref. des. 65-Z208 and when the AFCS (S102) switch in ref. des. 65-Z208 are closed and when the CADC Interlock Relay (K22A) is energized by applying power to the autopilot, and the Time Delay Relay (K29A) is energized by closing switch S102, power will be established thru the Roll Force Delay Relays (K28A and K28B) in ref. des. 65-AR305. If the Roll Force Switches (S203) in ref. des. 65-MT223 are open and S105 is then opened, current can flow thru the suppression diode of the Roll Force Switch Relay (K4A) and can flow to ground thru the Roll Damper Engage Relay and the Port and Starboard Series Servo Actuator Shutoff Valves.

This condition is terminated less than one second after S105 is opened by K29A contacts opening.

## POTENTIAL IMPACT

Some of the Roll Stabilator Augmenter circuitry will continue to be powered after the Roll Stability Augmentation Switch (S105) is opened. Due to the brief period of existence this condition likely would not be detected by the pilot.

## RECOMMENDATION

Add a diode in the location shown.

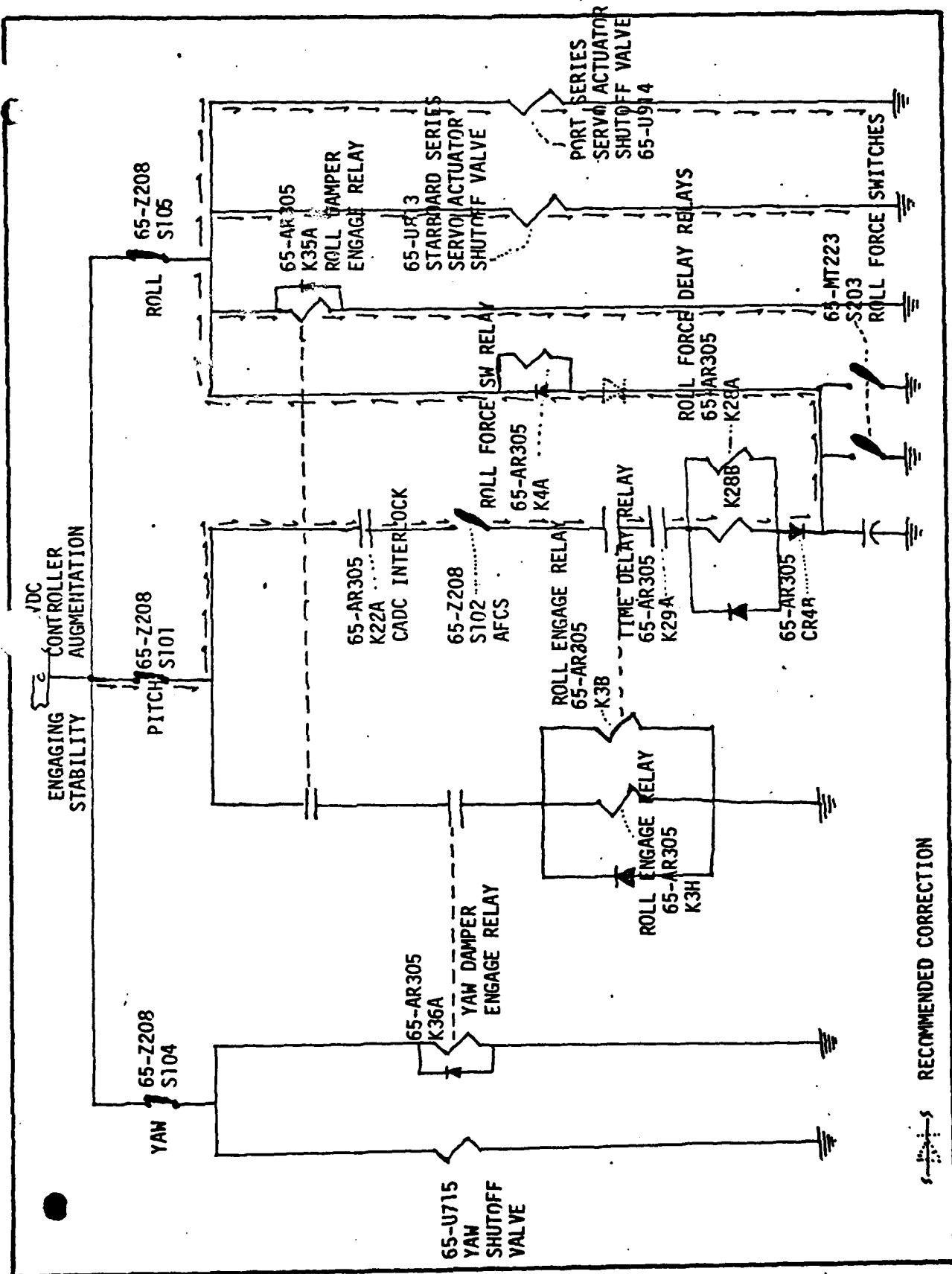

RECOMMENDED CORRECTION

TITLE Pitch Force Switch Does Not Always  
Disengage Altitude Hold

DATE 8/19/74

ENGINEER Gordon Buckley

*Gordon B. Buckley*

#### REFERENCES

- 1) G.E. Drawing 925C292, Revision C, 1-26-66
- 2) G.E. Drawing 281E402, Revision B, 2-5-74
- 3) T.O. IF-4C-2-16, Change 6, 3-1-74

#### MODULE/EQUIPMENT

Control Amplifier Part #230E420G4, Ref. Des. 65-AR305

#### EXPLANATION

The Pitch Force Switch is closed during pilot controlled pitch maneuvers. Closing Pitch Force Switch, with Altitude Hold Engaged, energizes K5A, which opens K5A contact pins 3 and 5. This de-energizes K8A which reapplies 90 volts to the Adder Attenuator Circuitry. After C158 and C23 are charged to approximately 21 volts, a path to ground is completed for K20A. With K20A energized, K20A contact pins 2 and 7 close and contact pins 1 and 7 open. This interrupts voltage to the holding relay for the Altitude Hold Switch, which drops out.

If the Pitch Force Switch is opened before C158 and C23 have been fully charged, then K20A will not energize and Altitude Hold will remain engaged.

#### POTENTIAL IMPACT

If Pitch Force Switch is opened before Altitude Hold drops out, the Air Data Computer error signal will cause the aircraft to return to the reference altitude.

#### RECOMMENDATION

The connections of K20A normally closed contact pins 1 and 7 and normally open contact pins 2 and 7 should be reversed.

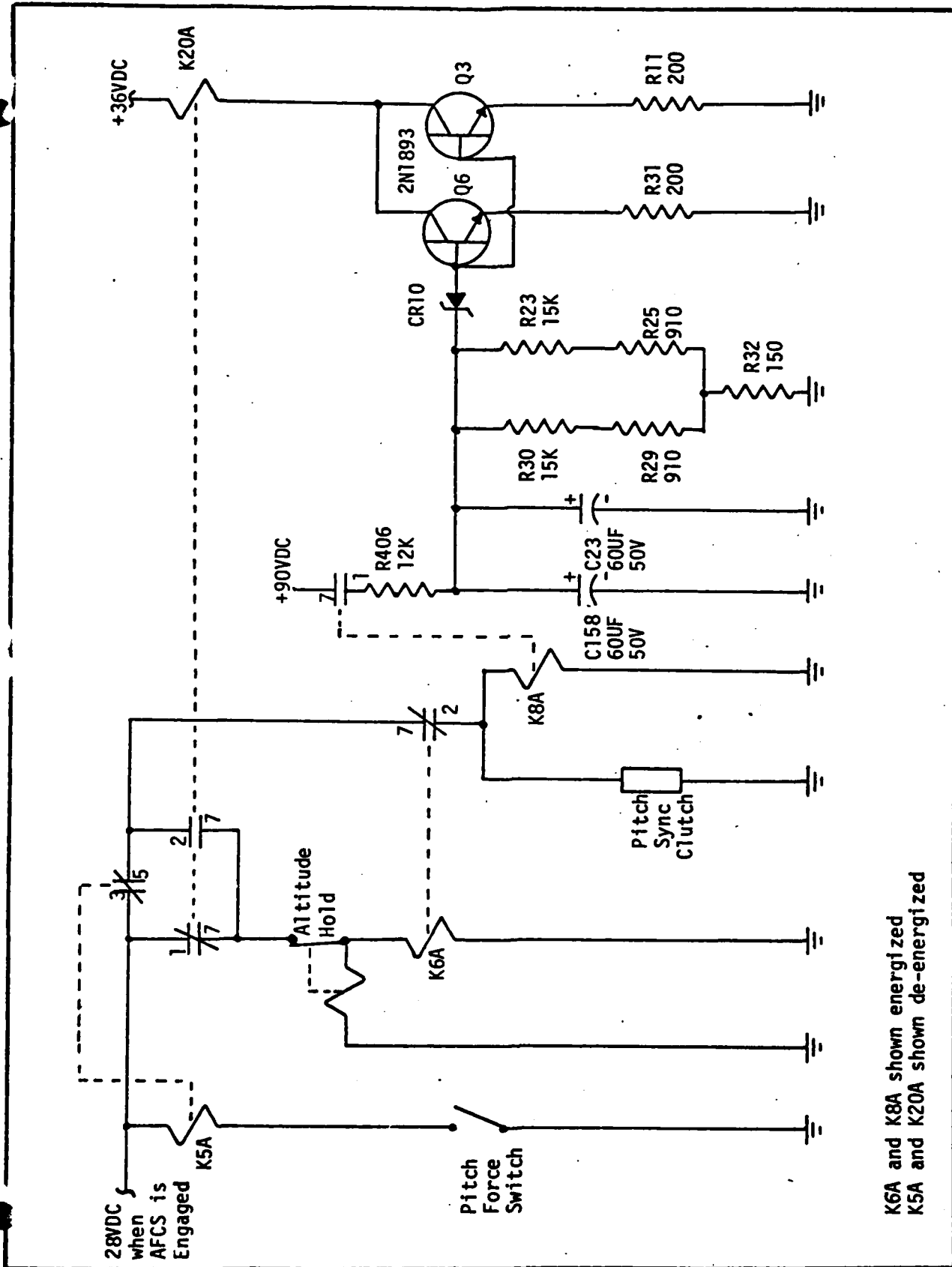

K6A and K8A shown energized  
 K5A and K20A shown de-energized

# SNEAK CIRCUIT REPORT

F-4C-4

TITLE Altitude Hold Switch May Drop Out After Engagement

DATE 8/19/74

ENGINEER Gordon Buckley

*Gordon B. Buckley*

## REFERENCES

- 1) G.E. Drawing 925C292, Revision C, 1-26-66
- 2) G.E. Drawing 281E402, Revision B, 2-5-74

## MODULE/EQUIPMENT

Control Amplifier Part #230E420G4, Ref. Des. 65-AR305

## EXPLANATION

When Altitude Hold Switch is engaged, K6A energizes and closes contact Pins 2 and 7. When K8A energizes and opens contact Pins 1 and 7, thus removing the 90 VDC from the Adder Attenuator. After C158 and C23 discharge below approximately 21 volts transistor Q3 and Q6 turn off and K20A loses its path to ground and de-energizes. When K20A de-energizes K20A contact Pins 1 and 7 close and K20A contact Pins 2 and 7 open. When these contacts are switching, the Altitude Hold Engage switch loses voltage to its holding coil.

## POTENTIAL IMPACT

Altitude Hold may disengage while K20A contacts are switching.

## RECOMMENDATION

Replace relay K20A with a relay with make before break contacts.

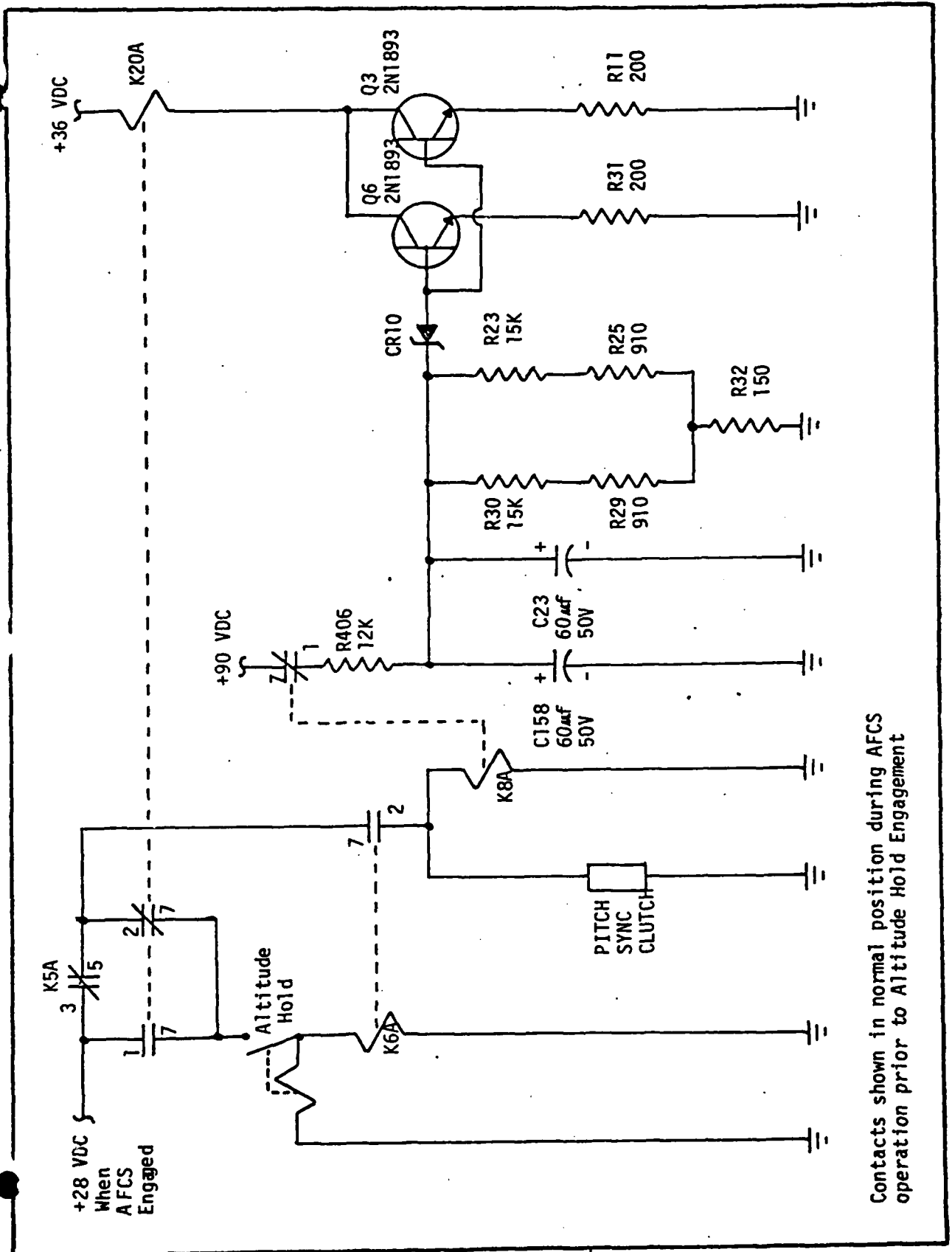

Contacts shown in normal position during AFCS operation prior to Altitude Hold Engagement

D2-118545-1

APPENDIX B  
DESIGN CONCERN REPORTS

## DESIGN CONCERN REPORT F-4C-1

TITLE Unsuppressed Relays in No. 3 Miscellaneous Relay Panel (52-Z327) of Automatic Flight Control System

DATE 7/9/74

ENGINEER Robert Clardy

*Robert Clardy*

## REFERENCES

T.O. IF-4C-2-23  
Change 13 March 15, 1974

## MODULE/EQUIPMENT

AFCS/52-Z327

## EXPLANATION

In Figure 5-31, original, the following relays are not diode suppressed:

65-K325 A/P Disengage Relay  
17-K303 TE Flaps Relay  
22-K311 L Wing Down Relay  
22-K310 R Wing Down Relay  
65-K327 Stab Aug. Caution Light Relay  
65-K324 A/P Disengage Relay  
65-K320 Caution Lights Relay

## POTENTIAL IMPACT

High voltage spike may damage associated switch contacts when power to coil is cut.

## RECOMMENDATION

Add suppression.

DESIGN CONCERN REPORT F-4C-2

TITLE Unsuppressed Relays in Trim Actuator Relay Panel (22-2737) of Automatic Flight Control System

DATE 7/9/74

ENGINEER Robert Clardy

*John Robert Clardy*

REFERENCES

T.O. IF-4C-2-23  
Change 13 March 15, 1974

MODULE/EQUIPMENT

AFCS/22-2737

EXPLANATION

In Figure 5-42, original, the following relays are not diode suppressed:

22-K728 Manual Trim - Nose Down  
22-K726 Manual Trim - Nose Up

POTENTIAL IMPACT

High voltage spike may damage associated switch contacts when power to coil is cut.

RECOMMENDATION

Add suppression.

## DESIGN CONCERN REPORT F-4C-3

TITLE Unsuppressed Relays in No. 1  
Miscellaneous Relay Panel

DATE 7-12-74

ENGINEER D. Self

## REFERENCES

T.O. IF-4C-2-23  
Change 13, March 15, 1974

## MODULE/EQUIPMENT

AFCS/52-Z357

## EXPLANATION

In Figure 3-102, original, the following relays are not diode suppressed:

65-K328 A/P Ground Pwr. Cutoff ~~AC~~  
65-K329 A/P Ground Pwr. Cutoff ~~BB~~  
65-K330 A/P Ground Pwr. Cutoff ~~BA~~

## POTENTIAL IMPACT

High voltage spikes may damage associated switch contacts when power to coil is cut.

## RECOMMENDATION

Add suppression.

# DESIGN CONCERN REPORT F-4C-4

TITLE Unsuppressed Relays in  
Compass Adapter Compensator

DATE	<u>7/12/74</u>
ENGINEER	<u>D. Self</u>
<i>ib</i>	<i>D. Self</i>

## REFERENCES

T.O. IF-2C-2-17  
Change 7 - 15 April 1974

## MODULE/EQUIPMENT

AFCS/30-Z306

## EXPLANATION

In Figure 3-102, original, the following relays are not diode suppressed:

- K901 Slaving Cutout
- K902 Auto Sync
- K903 Free-Slave
- K904 Slew
- K905 Compass
- K906 Fast Sync
- K907 Autopilot Cutout

## POTENTIAL IMPACT

High Voltage spikes may damage associated switch contacts when power to coil is cut.

## RECOMMENDATION

Add suppression.

# DESIGN CONCERN REPORT F-4C-5

TITLE Unnecessary Components in the Manual Trim Circuitry (22-Z732)

DATE 7/17/74

ENGINEER G.B. Buckley

*Gordon B. Buckley*

## REFERENCES

- 1) T.O. IF-4C-2-23 Change 13, 15 March 1974 Wiring Diagrams Series F-4C Aircraft Figure 5-42.
- 2) T.O. IF-4C-2-4 Change 8, 15 February 1974, Flight Control Systems USAF Series F-4C Aircraft Figure 3-2 Sheet 2.

## MODULE/EQUIPMENT

AFCS/22-Z732

## EXPLANATION

The Manual Trim-Nose Up Relay (22-K726) and the Manual Trim-Nose Down Relay (22-K728), shown in Figure 1, cannot be energized at the same time. Therefore, the normally closed contacts (A3-18/A2-18) of either 22-K726 or 22-K728 will provide continuity from Circuit Breaker 22-CB205 to the normally open contacts (A2-18/A1-18) of 22-K726 and 22-K728.

Thus, the normally closed contacts (A3-18/A2-18) of 22-K726 and 22-K728 provide unnecessary switching.

## POTENTIAL IMPACT

Unnecessary switching

## RECOMMENDATION

Delete the normally closed contacts (A3-18/A2-18) of 22-K726 and 22-K728 and replace them with continuity.

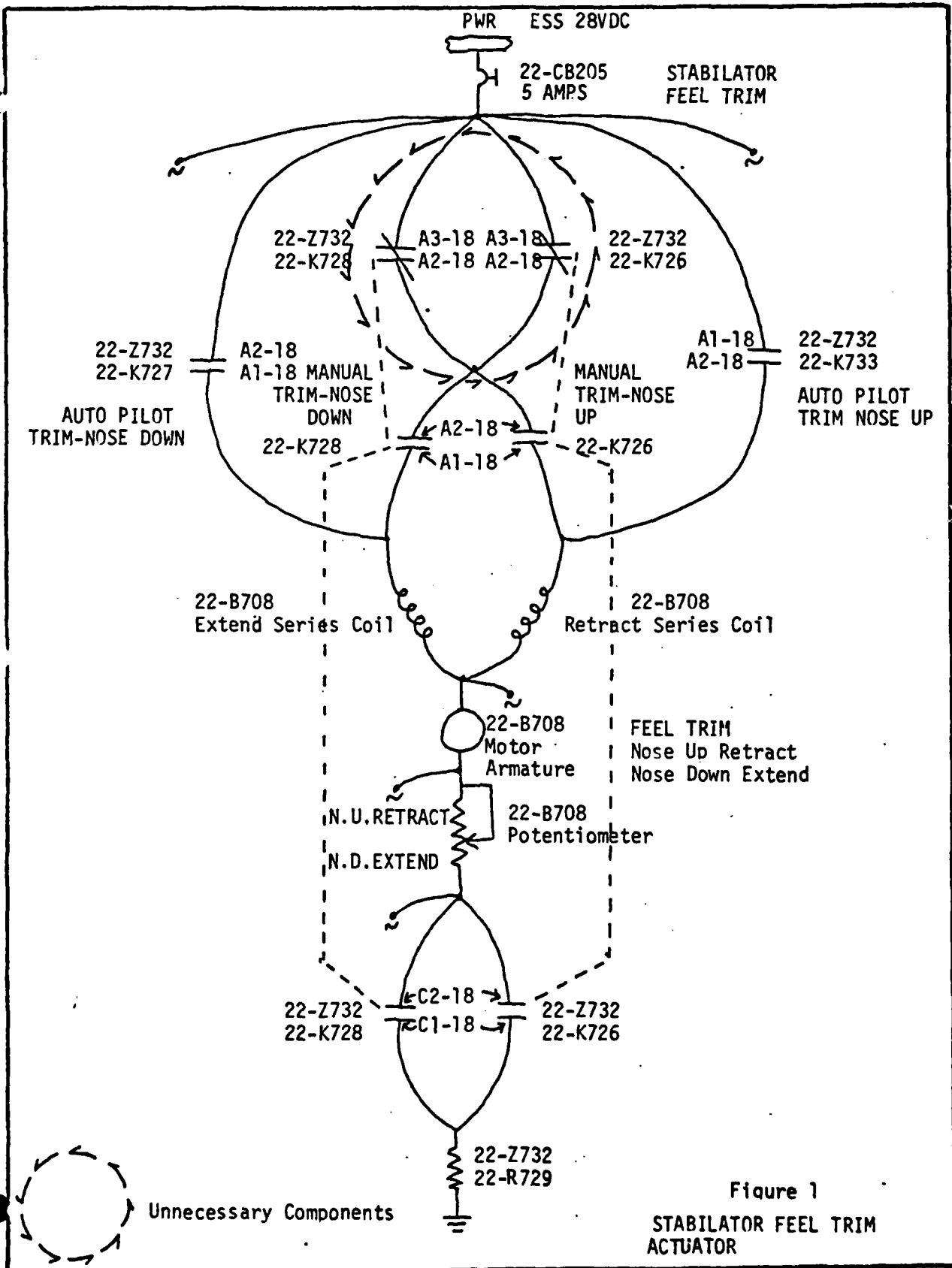

Figure 1  
STABILATOR FEEL TRIM  
ACTUATOR

## DESIGN CONCERN REPORT

F-4C-6

TITLE Parallel Capacitor with Opposite Polarity in Pitch Cancellor Amplifier Circuitry

DATE 7/16/74ENGINEER Robert Clardy*file Robert Clardy*

## REFERENCES

- 1) T.O. 5A1-2-42-2, Change 4, December 15, 1973, Figure 5-6, Change 4, Sheet 4.
- 2) G.E. Dwg. 281E402, Revision B, Sheet 1
- 3) G.E. Dwg. 925C293, Revision C, Sheet 1

## MODULE/EQUIPMENT

AFCS/Control Amplifier 65-AR305 and module A4, the Pitch Cancellor Amplifier.

## EXPLANATION

Capacitor C165 in ref. des. 65-AR305 is wired in parallel with capacitor C3 in ref. des. 65-AR305A4. The drawings in references 2 and 3 above show these capacitors wired with opposite polarity as shown in Figure 1. If these are electrolytic capacitors, one of them may burn out.

The drawings for the YAW Cancellor Amplifier does not show the Capacitors in these locations with opposite polarities.

## POTENTIAL IMPACT

Either capacitor C165 or C3 may burn out.

## RECOMMENDATION

Reverse polarity of capacitor C165.

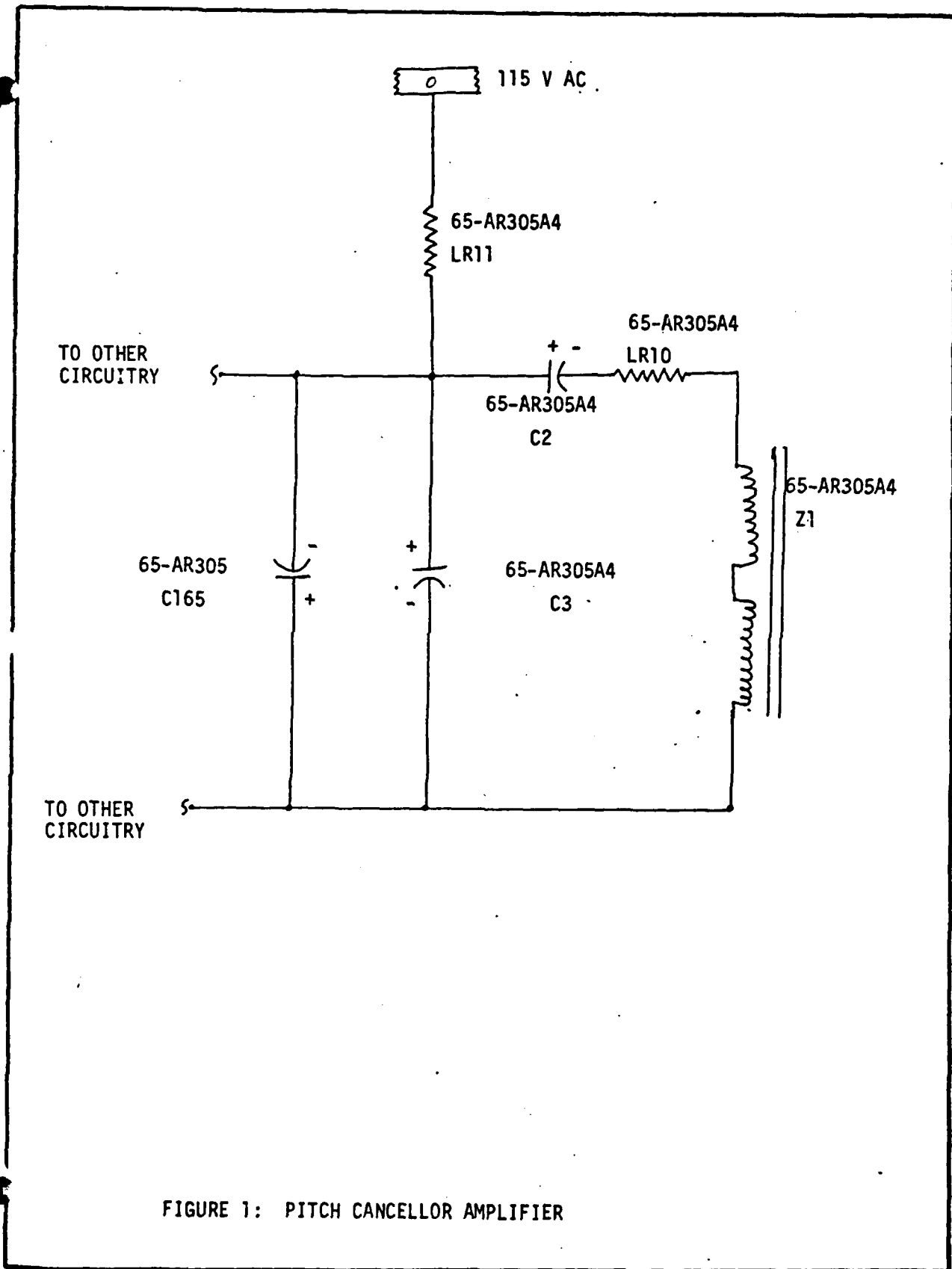

FIGURE 1: PITCH CANCELLOR AMPLIFIER

## DESIGN CONCERN REPORT F-4C-7

TITLE Capacitor Failure Due to Diode Failure

DATE 7/30/74ENGINEER P. F. Stokes*P. F. Stokes*

## REFERENCES

- 1) G.E. Drawing 281E402, Revision B, Dated 2-5-74.
- 2) G.E. Drawing 925C292, Revision C, Dated 1-26-66.
- 3) G.E. Drawing 702C190, Revision C, Dated 3-31-65
- 4) Illustrated Parts Breakdown, T.O. 5A3-50-4, Change 1, Dated 1 April 1973
- 5) MIL-STD-198C, Dated 29 September 1972.

## MODULE/EQUIPMENT

Control Amplifier, P/N 230E420G4, Ref. Des. 65-AR305

## EXPLANATION

Diodes CR50, CR51 and CR52 rectify the incoming 115VAC, 400 Hz, 3 phase power to provide 135 VDC to the Adder Attenuator and Electronic Switch Monitor. This voltage is filtered by capacitors C50, C51, C158 and C23. C23 is located in the Adder Attenuator Module. The remaining capacitors are chassis mounted components. Should any of the diodes fail in the shorted mode (then fail open) each of the four capacitors will be subjected to reverse current during the negative portion of the cycle for the phase containing the shorted diode. Per reference 4 these capacitors are of the Tantalum Sintered-Slug type. Per MIL-STD-198C, Section 802, paragraph 2.1.2 these capacitors cannot withstand any reverse voltage.

## POTENTIAL IMPACT

Capacitors may fail immediately or be damaged to the extent that they will fail later - possibly in flight. Capacitor C51 failure will prevent AFCS from being engaged. Capacitor C158 or C23 failure results in the loss of the pitch fader effect. Capacitor C50 failure results in the loss of both pitch and roll fader effects.

## RECOMMENDATION

Add one additional diode in series with CR50, CR51 and CR52 as shown in the attached figure.

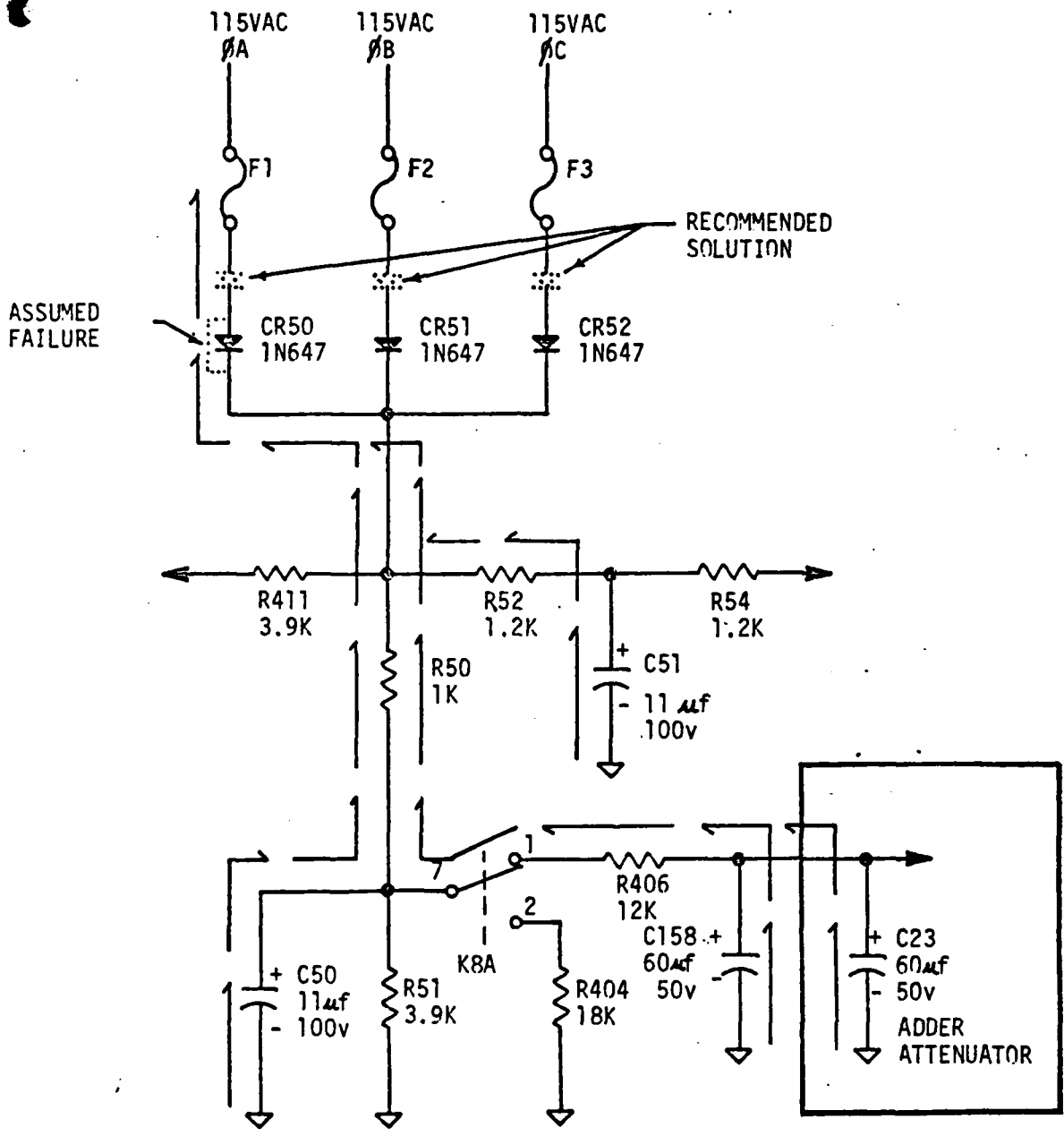

DESIGN CONCERN REPORT F-4C-7

← REVERSE CURRENT PATH

## DESIGN CONCERN REPORT

F-4C-8

TITLE Loss of Roll Fader

DATE 8/1/74

ENGINEER P.F. Stokes

*P. F. Stokes*

## REFERENCES

- 1) G.E. Drawing 281E402, Revision B, Dated 2-5-74.
- 2) G.E. Drawing 925C292, Revision C, Dated 1-26-66.
- 3) Illustrated Parts Breakdown, T.O.5A3-50-4, Change 1, Dated 1 April 1973.
- 4) MIL-STD-198C, dated 29 September 1972.

## MODULE/EQUIPMENT

Control Amplifier, P/N 230E420G4, Ref. Des. 65-AR305

## EXPLANATION

Capacitors C400, C401 in the chassis wiring and capacitor C3 in the Adder Attenuator are connected in parallel as shown in the attached figure. The working voltage for C400 and C401 is 30 volts and for C3 is 50 volts. Per reference 2, the nominal voltage across these capacitors is 31.9 volts. Depending upon the setting of R410 this can be as high as 39.8 volts. In either case, the working voltage for C400 and C401 is exceeded. This is in violation of MIL-STD-198C, Section 802, Paragraph 2.7.2.

## POTENTIAL IMPACT

Capacitor failure which in turn results in the loss of the roll fader effect in the Adder Attenuator module.

## RECOMMENDATION

Replace C400 and C401 with capacitors with sufficient working voltage to withstand the applied voltages.

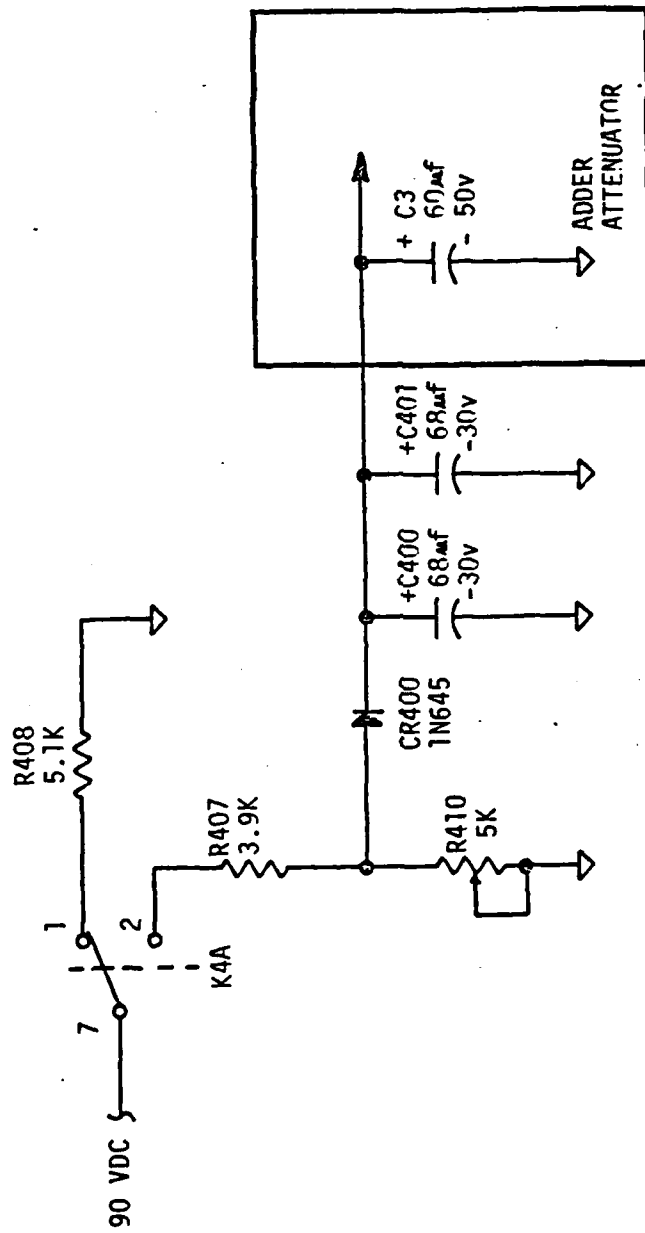

DESIGN CONCERN REPORT F-4C-8

## DESIGN CONCERN REPORT

F-4C-9

PAGE 1 OF 2

TITLE Loss of Pitch and Roll Fader

DATE 8/1/74

ENGINEER P.F. Stokes

*P.F. Stokes*

## REFERENCES

- 1) G.E. Drawing 281E402, Revision B, dated 2-5-74.
- 2) G.E. Drawing 925C292, Revision C, dated 1-26-66.
- 3) Illustrated Parts Breakdown, T.O. 5A3-50-4, Change 1, dated 1 April 1973.
- 4) MIL-STD-198C, dated 29 September 1972.

## MODULE/EQUIPMENT

Control Amplifier, P/N 230E420G4, Ref. Des. 65-AR305

## EXPLANATION

Capacitor C50 filters the 90 VDC used to control the Pitch and Roll faders in the Adder Attenuator module. During the switching time of relay K4A the voltage applied to C50 is 109 VDC due to the loss of the 5.1K $\Omega$  load impedance. This exceeds the rated working voltage of the capacitor in violation of MIL-STD-198C, paragraph 6.5(d).

## POTENTIAL IMPACT

Capacitor failure which in turn results in the loss of the pitch and roll fader effects in the Adder Attenuator.

## RECOMMENDATION

Replace capacitor C50 with a capacitor with sufficient working voltage to withstand the applied voltage.

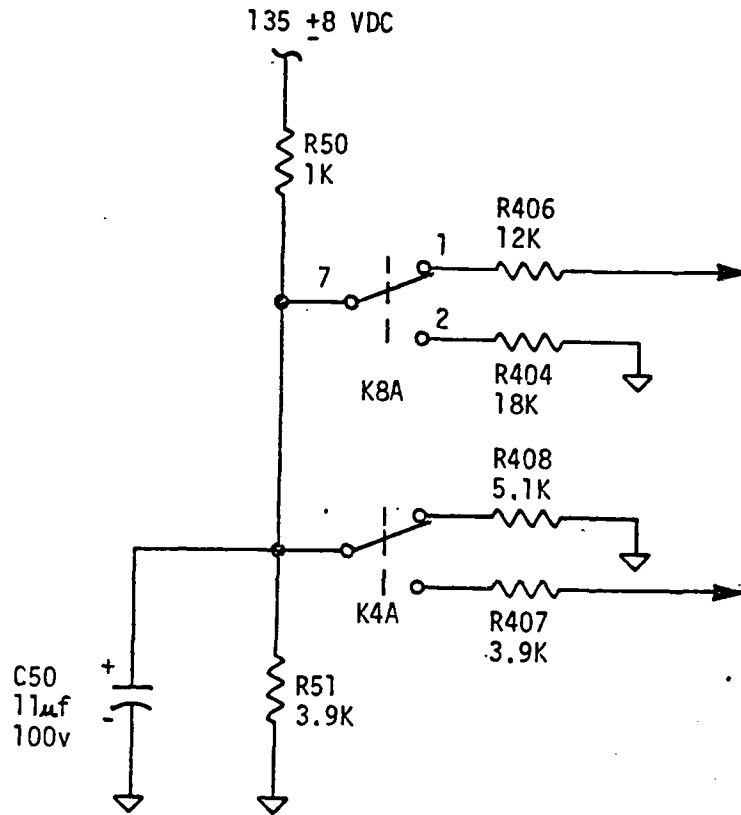

DESIGN CONCERN REPORT F-4C-9

## DESIGN CONCERN REPORT F-4C-10

TITLE Transient Suppression

DATE 8-9-74

ENGINEER P.F. Stokes

*P. F. Stokes*

## REFERENCES

- 1) G.E. Drawing 281E402, Revision B, dated 2-5-74.
- 2) Illustrated Parts Breakdown, T.O. 5A3-50-4, Change 1, dated 1 April 1973.
- 3) MIL-C-39014B, dated 21 August 1970

## MODULE/EQUIPMENT

Control Amplifier, P/N 230E420G4, Ref. Des. 65-AR305.

## EXPLANATION

Capacitors C4A, C4B and C4C, P/N CK06BX103M, are Fixed, Ceramic dielectric devices rated at .01  $\mu$ f, 200 VDCW. These capacitors are used to both tune the circuit and suppress transients caused by opening the circuits to the fixed phase winding of the Pitch, Roll and Course Sync Drive Motors as shown in the attached figure. Per reference 3, paragraph 4.7.5.1 these capacitors must withstand 500 VDC without a dielectric failure. Considering the high failure rate of these capacitors, it is probable that the induced voltage transients exceed the dielectric breakdown voltage thus causing capacitor failure.

## POTENTIAL IMPACT

Loss of one or more autopilot channel.

## RECOMMENDATION

Replace capacitors with devices that will withstand the induced voltage transients without dielectric breakdown.

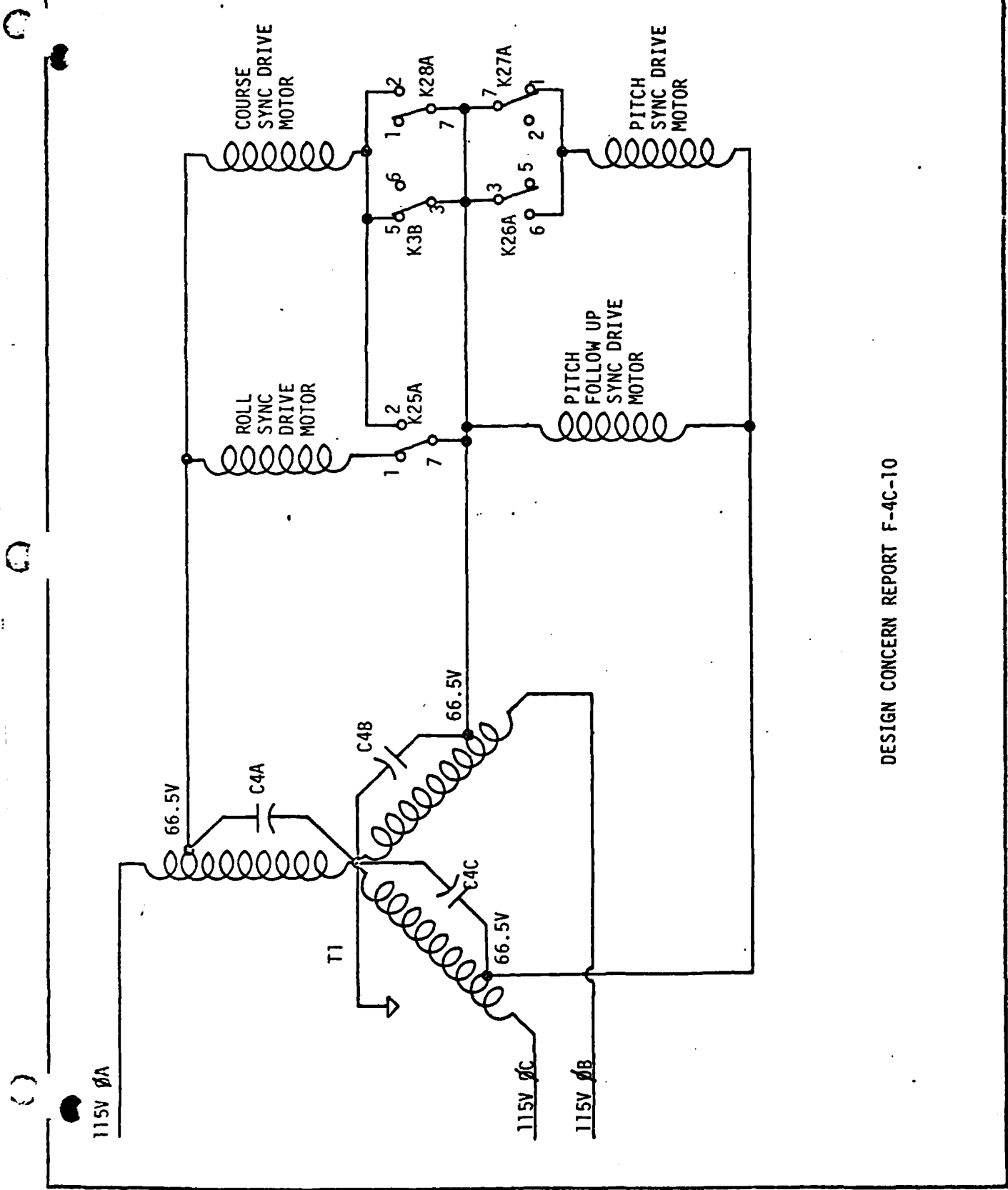

DESIGN CONCERN REPORT F-4C-10

This report is the property of the Department of Defense and is loaned to your organization. It and its contents are not to be distributed outside your organization.

## DESIGN CONCERN REPORT F-4C-11

TITLE Loss of Servo Amplifier

DATE 8/12/74

ENGINEER P.F. STOKES

*P. F. Stokes*

## REFERENCES

- 1) G.E. Drawing 281E402, Revision B, dated 2-5-74
- 2) Illustrated Parts Breakdown, T.O. 5A3-50-4, Change 1, Dated 1 April 1973
- 3) MIL-C-3965/17A, dated 16 August 1961

## MODULE/EQUIPMENT

Control Amplifier, P/N 230E420G4, Ref. Des. 65-AR305

## EXPLANATION

Capacitors C103A, C103B, C202A, C202B, C203A, C203B, C302A and C302B in the chassis wiring are Tantalum, Etched Foil devices, P/N CL21CN01OSP3, rated at 1  $\mu$ f, 100 VDCW. These capacitors are used to tune the output stage of each servo amplifier. The capacitors are not hermetically sealed thus are susceptible to electrolyte leakage at higher altitudes.

## POTENTIAL IMPACT

Unexpected aircraft maneuver if capacitor fails shorted.

## RECOMMENDATION

Replace these capacitors with hermetically sealed devices.

## DESIGN CONCERN REPORT

F-4C-12

TITLE Module Sealing Process Contributes to  
Capacitor Failure

DATE 8-15-74ENGINEER P.F. STOKES*P.F. Stokes*

## REFERENCES

- 1) Depot Overhaul Manual, T.O. 5A3-50-3
- 2) Illustrated Parts Breakdown, T.O. 5A3-50-4, Change 1, Dated 1 April 1973.

## MODULE/EQUIPMENT

Control Amplifier, P/N 230E420G4, Ref. Des. 65-AR305

## EXPLANATION

Each capacitor listed in the attached table are Tantalum, Wet-slug devices with ratings as shown. None of the capacitors are hermetically sealed. The module sealing process described in reference 1 is a possible cause of the high failure rate experienced by these capacitors. The sealing process requires that after the module cover is attached to the base, the module be placed in a chamber and the chamber evacuated. The chamber is then filled with nitrogen. This process is repeated two more times after which the module is removed from the chamber and the small hole in the cover is soldered closed. Evacuating the chamber has the same effect on the capacitor that high altitude does, (i.e. electrolyte leakage may occur).

## POTENTIAL IMPACT

Capacitor failure due to electrolyte leakage.

## RECOMMENDATION

Replace all capacitors with hermetically sealed devices. Review module sealing process to assure that no further capacitor failures will be induced by this process.

MODULE	SYMBOL	$\mu$ f	VDCW	PART NUMBER
Canceller Amp.	C1	22	100	CL65CN220MP3
Servo Amp.	C2	30	100	CL65CN300MP3
	C3	30	100	CL65CN300MP3
Sync Drive Amp.	C6	5	50	CL65CJ050MP3
	C7	22	100	CL65CN220MP3
Adder Atten.	C3	60	50	CL65CJ600MP3
	C23	60	50	CL65CJ600MP3

TITLE Suppression Diode Failure and Loss of AFCS  
Engage Due to Diode Failure

DATE 8-16-74

ENGINEER D.C.SELF

#### REFERENCES

T.O. 5A1-2-42-2, Fig. 5-6, Change 2

#### MODULE/EQUIPMENT

Control Amplifier, P/N 230E420G3, Ref. Des. 65-AR305

#### EXPLANATION

Diodes CR53, CR54, and CR55 rectify the incoming 8.7 VAC 400 Hz, 3-Phase voltage to provide 9.5 VDC to the G-limit relays through the G-limit accelerometer switches as shown in the attached Figure 1. If any of the three diodes fail in the shorted mode, the voltage to the G-limit accelerometer will be driven negative during the negative cycle of the phase containing the shorted diode. This will cause current flow through the suppression diodes of K13A and K14A in the forward direction, as shown, causing them to fail open. Also, during the negative portion of the shorted phase, the two remaining diodes will supply excessive current, causing one or both to fail open. The negative voltage at the input to the G-limit accelerometer will have the same effect as opening the G-limit switches: De-energizing of K13A and K14A and disengaging AFCS (AFCS engage logic is shown in Attached Figure 2).

#### POTENTIAL IMPACT

AFCS will not remain engaged after failure of any of the diodes in shorted mode.

#### RECOMMENDATION

Add an additional diode in series with each of the three diodes as shown in Figure 1.

This DCR is applicable to control amplifier 230E420G3 and earlier.

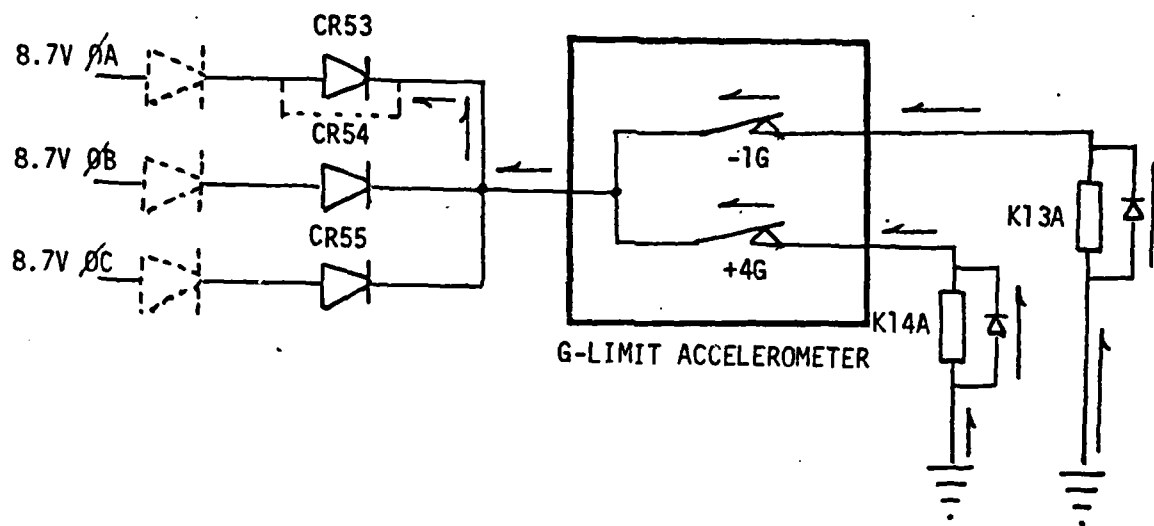
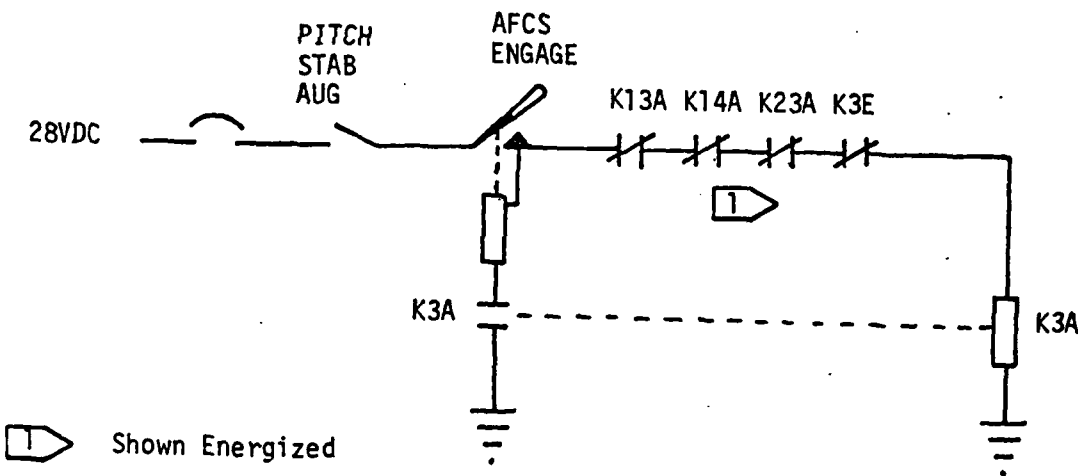

FIGURE 1 G-LIMIT ACCELEROMETER AND RELAYS



 Shown Energized

FIGURE 2 - AFCS ENGAGE LOGIC

# DESIGN CONCERN REPORT

F-4C-14

TITLE Component Failures in Control Amplifier B +  
Power Supply

DATE 8/16/74

ENGINEER D. C. Self  
*DC Self*

## REFERENCES

- G.E. Drawing 281E402, Rev. B, 2/5/74
- T.O. 1F-4C-2-23, Figure 3-63, Change 8
- T.O. 1F-4C-2-23, Fig. 3-66, Change 5
- T.O. 1F-4C-2-16, Para. 2-36, Change 6

## MODULE/EQUIPMENT

Control Amplifier, P/N 230E420G4, Ref. Des. 65 AR305

## EXPLANATION

The high failure rate of some components in the Control Amplifier B+ power supply may be attributed to transients resulting from AC generator switching. T.O. 1F-4C-2-16, para. 2-36, indicates that the FCG will experience transients when starting or stopping the left generator with the right generator on the line or by stopping the right generator with the left generator on the line.

At certain times generator switching causes interruption of bus power and disengages AFCS. The high failure rate components in the B+ power supply (CR50, CR51, CR52, R50, C50, C51) receive power even though the AFCS is disengaged and are subjected to switching transients at all times. A complete analysis cannot be made due to insufficient information.

## POTENTIAL IMPACT

High failure rate of power supply components due to generator switching transients.

## RECOMMENDATION

Removal of AC power from the control amplifier during generator switching should be considered if further investigation shows that component failures are caused by switching transients.

D2-118545-1

APPENDIX C  
DRAWING ERROR REPORTS

DZ-110043-1  
**SNEAK CIRCUIT DRAWING ERROR REPORT F-4C-1**

TO: Earl Parker

PROJECT: F-4C

DOCUMENT NO.	REFERENCE DESIGNATOR	SUBSYSTEM
G. IF-4C-2-23, Fig. 3-102, Change 13	N/A	AFCS

UNIT NOMENCLATURE  
 Wiring Diagrams, USAF Series F-4C Aircraft

**DISCREPANCY:**

Figure 3-102 has wire No. from 65-MT223 "Motiona1 Pickup Transducer", 52-P242 Pin Z as C410D22.

On Figure 3-104 the same wire has a wire No. of C502A22.

**ASSUMED CORRECTION:**

D. IF-4C-2-16, Change 5, Figure 3-6 agrees with Figure 3-104 of T.O. IF-4C-2-23 therefore, it is assumed that the wire no. should be C502A22.

REPORTED BY P. F. Stokes *P. F. Stokes* DATE 6/12/74

SNEAK CIRCUIT GROUP ACTION BY *J. B. Campbell* DATE 6/12/74  
J. B. Campbell

CONTACT NAME \_\_\_\_\_ DATE \_\_\_\_\_

CONTRACTOR CONCURRENCE BY \_\_\_\_\_ DATE \_\_\_\_\_

SNEAK CIRCUIT DRAWING ERROR REPORT F-4C-2

TO: Earl Parker

PROJECT: F-4C

DOCUMENT NO. 0. IF-4C-2-17 Change 7 4-15-72	REFERENCE DESIGNATOR 65AR305	SUBSYSTEM AFCS
--	---------------------------------	-------------------

UNIT NOMENCLATURE

Avionics Navigation Instrument Systems USAF Series F-4C Aircraft

DISCREPANCY:

Discrepancies exist in the K904 Relay Contacts Configuration in the following drawings:

1) T.O. IF-4C-2-17, Figure 2-24, Sheet 3, Original.

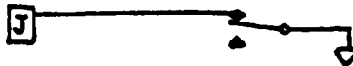

2) T.O. IF-4C-2-17, Figure 2-29, Sheet 2, Original.

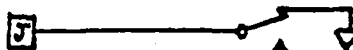

3) T.O. IF-4C-2-16, Figure 2-39, Sheet 2, Change 5.



ASSUMED CORRECTION:

Assumed T.O. IF-4C-2-17, Figure 2-24 K904 Relay Contact Configuration to be correct.

REPORTED BY Gordon B. Buckley Gordon B. Buckley DATE 6/25/74

SNEAK CIRCUIT GROUP ACTION BY Paul J. Stokes DATE 6-26-74

CONTACT NAME \_\_\_\_\_ DATE \_\_\_\_\_

CONTRACTOR CONCURRENCE BY \_\_\_\_\_ DATE \_\_\_\_\_

## SNEAK CIRCUIT DRAWING ERROR REPORT F-4C-3

TO: Earl Parker

PROJECT: F-4C

DOCUMENT NO. T.O. IF-4C-2-16  
Change 6, dated 1 March 1974REFERENCE DESIGNATOR  
30Z306SUBSYSTEM  
AFCS

## JIT NOMENCLATURE

Automated Flight Control Systems USAF Series F-4C Aircraft

## DISCREPANCY:

T.O. IF-4C-2-16, Figure 2-39, Change 5, disagrees with T.O. IF-4C-2-17, Change 7, April 15, 1974, Figure 2-24, Original, in the following particulars:

- 1) Pin number J was not labeled in Figure 2-39.
- 2) Diode shown on the attached sheet is present in Figure 2-24, but missing from 2-39.

## ASSUMED CORRECTION:

Diode shown in T.O. IF-4C-2-17, Figure 2-24, should be added to T.O. IF-4C-2-16, Figure 2-39.

"Pin J" on connector 30P306A should be added to Figure 2-39.

REPORTED BY Robert Clardy *Robert Clardy* DATE 6/25/74

SNEAK CIRCUIT GROUP ACTION BY Paul J. Stokes DATE 6-26-74

CONTACT NAME \_\_\_\_\_ DATE \_\_\_\_\_

CONTRACTOR CONCURRENCE BY \_\_\_\_\_ DATE \_\_\_\_\_

T.O. IF-4C-2-16, Change 6, March 1, 1974  
 Figure 2-39, Change 5

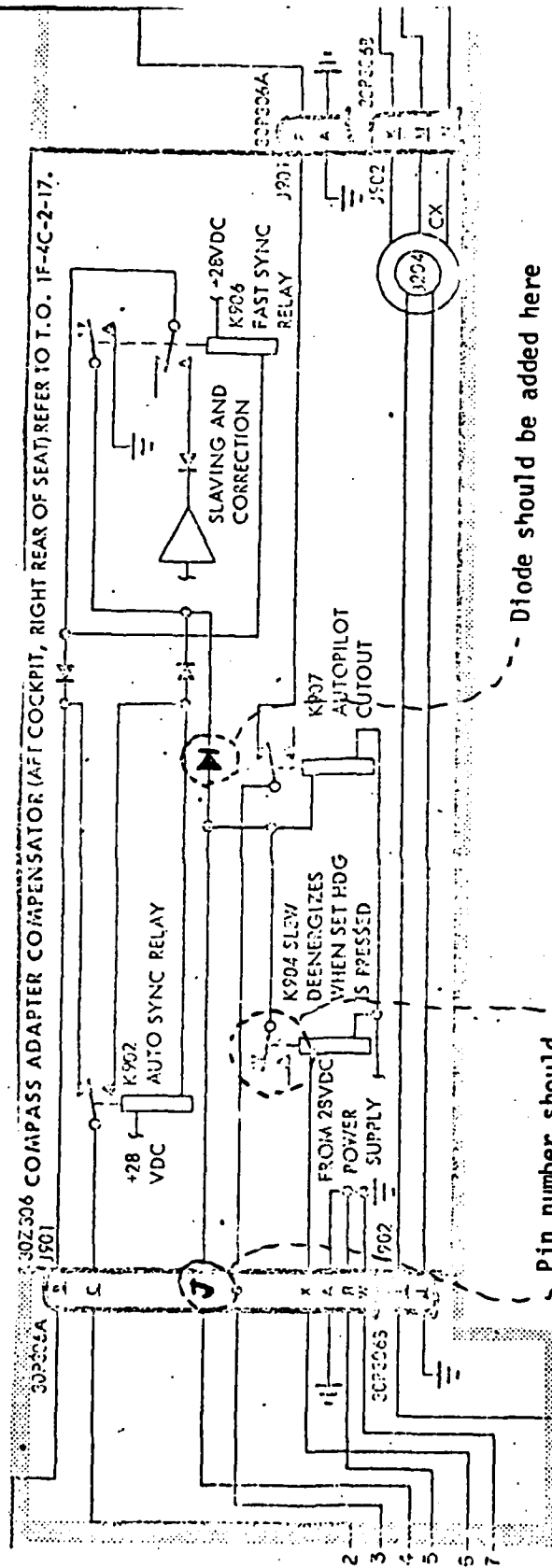

Diode should be added here

Errors in this switch reported in Drawing Error Report #2

Pin number should be added here

# SNEAK CIRCUIT DRAWING ERROR REPORT F-4C-4

TO: Earl Parker

PROJECT: F-4C

DOCUMENT NO. T.O. 5A1-2-42-2, Change 4, 12-15-73	REFERENCE DESIGNATOR 65Z208	SUBSYSTEM AFCS
---	--------------------------------	-------------------

**UNIT NOMENCLATURE**

Automatic Flight Control Systems AN/ASA-32J and AN/ASA-32M

**DISCREPANCY:**

For switches S101, S104, and S105 there is a discrepancy in pin numbers and type of contacts (momentary or latching) in the following drawings:

- 1) T.O. 5A1-2-42-2, Figure 5-12, Change 2  
Normally Open, Latching. H common to all pin 3 contacts.
  
- 2) Schematic, Electrical-System AN/ASA-32M Control Circuits  
Drawing #281E402, Sheet 4, Revision A, 2-16-71  
Normally Open, Latching. H common to all pin 1 contacts.
  
- 3) Schematic, Electrical-Engaging Controller  
Drawing #702187, Rev. C, 5-7-69  
Normally Closed, Momentary. H common to all pin 3 contacts.

**ASSUMED CORRECTION:**

Insufficient information to determine correct configuration.

*Gordon B. Buckley*

REPORTED BY Gordon B. Buckley DATE 6/24/74

SNEAK CIRCUIT GROUP ACTION BY Paul J. Stokes DATE 6-26-74

CONTACT NAME \_\_\_\_\_ DATE \_\_\_\_\_

CONTRACTOR CONCURRENCE BY \_\_\_\_\_ DATE \_\_\_\_\_

1) T.O. 5A1-2-42-2, Figure 5-12, Change 2

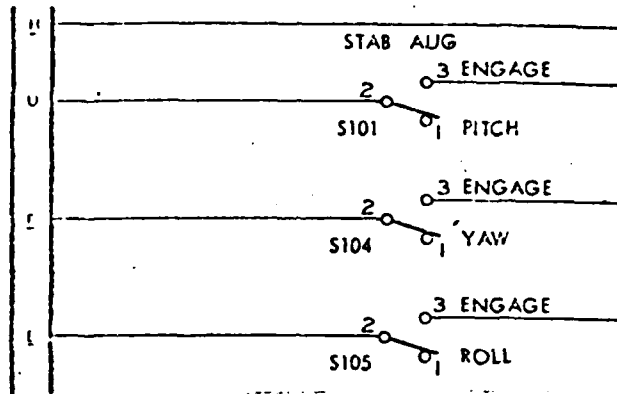

2) 281E402, Sheet 4, Rev. A, 2-16-71

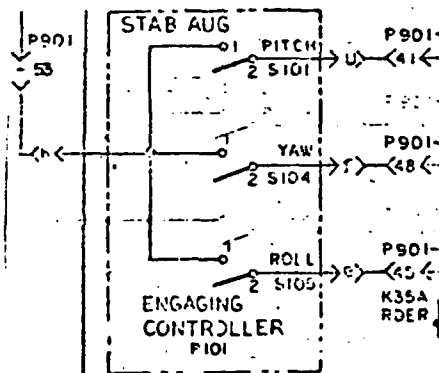

3) 702187, Rev. C, 5-7-69

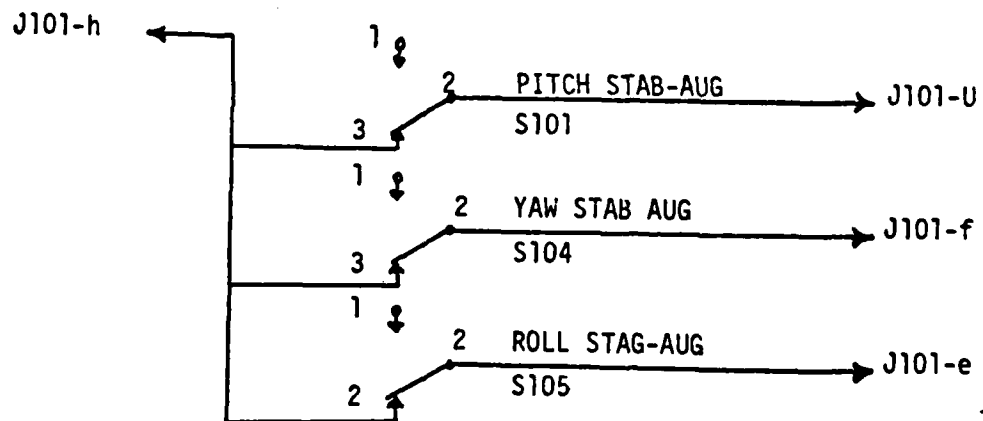

# SNEAK CIRCUIT DRAWING ERROR REPORT F-4C-5

TO: Earl Parker

PROJECT: F-4C

DOCUMENT NO. T.O. IF-4C-2-16 Change 6, dated 1 March 1974	REFERENCE DESIGNATOR 19DS202	SUBSYSTEM AFCS
--	---------------------------------	-------------------

**NIT NOMENCLATURE**

Automatic Flight Control System USAF Series F-4C Aircraft

**DISCREPANCY:**

In T.O. IF-4C-2-16, Figure 4-3, Sheet 4-6, Change 5, the "Stabilator Feel Trim Position Indicator" reference designator is shown as 19DS101.

In T.O. IF-4C-2-23, Figure 3-55, this indicator is labeled 19DS202. Also 19DS101 does not appear in the reference designator index of T.O. IF-4C-2-23.

**ASSUMED CORRECTION:**

The "Stabilator Feel Trim Position Indicator" reference designator should be 19DS202 in T.O. IF-4C-2-16.

REPORTED BY Robert Clardy *Robert Clardy* DATE 6/25/74

SNEAK CIRCUIT GROUP ACTION BY Paul F. Stokes *Paul F. Stokes* ✓ DATE 6-26-74

CONTACT NAME \_\_\_\_\_ DATE \_\_\_\_\_

CONTRACTOR CONCURRENCE BY \_\_\_\_\_ DATE \_\_\_\_\_

SNEAK CIRCUIT DRAWING ERROR REPORT

TO: Earl Parker

PROJECT: F-4C

DOCUMENT NO. T.O. IF-4C-2-4 Change 8 2-15-74	REFERENCE DESIGNATOR N/A	SUBSYSTEM FCS
---	-----------------------------	------------------

UNIT NOMENCLATURE

Flight Control Systems USAF Series F-4C Aircraft

DISCREPANCY:

Differences exist between T.O. IF-4C-2-4, Figure 3-2, Sheet 1, Original, and other figures of T. O. IF-4C-2-23 as follows:

- 1) Automatic Flight Control Amplifier has different Ref. Des. than T.O. IF-4C-2-23, Change 13, 3-15-74, Figure 3-102, Sheet 3, Original.
- 2) No. 3 Miscellaneous Relay Panel has different Ref. Des. and pin numbers than T.O. IF-4C-2-23, Figure 3-76, Sheet 4, Change 5.

ASSUMED CORRECTION:

Drawings of T.O. IF-4C-2-23 are assumed correct.

REPORTED BY Gordon B. Buckley *Gordon B. Buckley* DATE 6/25/74

SNEAK CIRCUIT GROUP ACTION BY *Paul F. Stokes* DATE 6-26-74

CONTACT NAME \_\_\_\_\_ DATE \_\_\_\_\_

CONTRACTOR CONCURRENCE BY \_\_\_\_\_ DATE \_\_\_\_\_

D2-118545-1  
SNEAK CIRCUIT DRAWING ERROR REPORT F-4C-7

TO: Earl Parker

PROJECT: F-4C

DOCUMENT NO.: T.O. IF-4C-2-23  
Change 13 dated 15 March 74

REFERENCE DESIGNATOR  
65-MT223

SUBSYSTEM  
A.F.C.S.

ITEM NOMENCLATURE

Wiring Diagram, USAF Series F-4C Aircraft

DISCREPANCY:

Figure 3-102, Original, has Switch S-203 labeled "Roll Force Switch" and Switch S-202 labeled "Pitch Force Switch".

These switch labels are reversed in T.O. 5A1-2-42-2 Change 4 dated 15 December, 1973, - Figure 5-17, Original.

ASSUMED CORRECTION:.

It is assumed that T.O. 5A1-2-42-2 is correct and that the labels of switches S-203 and S-202 should be reversed in T.O. IF-4C-2-23, Figure 3-102.

REPORTED BY Robert Clardy Robert Clardy DATE 6/25/74

SNEAK CIRCUIT GROUP ACTION BY Paul F. Stokes DATE 6-26-74

CONTACT NAME \_\_\_\_\_ DATE \_\_\_\_\_

CONTRACTOR CONCURRENCE BY \_\_\_\_\_ DATE \_\_\_\_\_

D2-118545-1  
**SNEAK CIRCUIT DRAWING ERROR REPORT** F-4C-8

TO: Earl Parker

PROJECT: F-4C

DOCUMENT NO. T.O. IF-4C-2-17  
Change 7 dated 15 April 1974

REFERENCE DESIGNATOR  
30Z306

SUBSYSTEM  
AFCS

**NIT NOMENCLATURE**

Avionics Navigation Instrument Systems, USAF Series F-4C Aircraft

**DISCREPANCY:**

T.O. IF-4C-2-17, Figure 2-29, Original, shows a connection thru a diode between Pins B and J on connector 309P306A. This connection does not exist in Figure 2-24 page 2-144 of T.O. IF-4C-2-17.

**ASSUMED CORRECTION:**

Insufficient information to determine proper configuration.

REPORTED BY Robert Clardy *Robert Clardy* DATE 6/25/74

SNEAK CIRCUIT GROUP ACTION BY Paul F. Stokes DATE 6-26-74

CONTACT NAME \_\_\_\_\_ DATE \_\_\_\_\_

CONTRACTOR CONCURRENCE BY \_\_\_\_\_ DATE \_\_\_\_\_



SNEAK CIRCUIT DRAWING ERROR REPORT

F-4C-10

TO: Earl Parker

PROJECT: F-4C

DOCUMENT NO.  
G.E. Drawing 925C292

REFERENCE DESIGNATOR  
65-AR305A1

SUBSYSTEM  
AFCS

ITEM NOMENCLATURE

Adder Attenuator

DISCREPANCY:

Drawing 925C292 shows rectifiers CR9 and CR10 as ordinary diodes.

Figure 3-3, of T.O. 5A1-2-42-2, change 4, July 1, 1972 shows them as zener diodes.

ASSUMED CORRECTION:

They should be zener diodes as shown in T.O. 5A1-2-42-2.

REPORTED BY Robert Clardy Robert Cloudis DATE 7-15-74

SNEAK CIRCUIT GROUP ACTION BY Julius B Campbell DATE 7-18-74

CONTACT NAME \_\_\_\_\_ DATE \_\_\_\_\_

CONTRACTOR CONCURRENCE BY \_\_\_\_\_ DATE \_\_\_\_\_

D2-118545-1

SNEAK CIRCUIT DRAWING ERROR REPORT

F-4C-11

TO: Earl Parker

PROJECT: F-4C

DOCUMENT NO. T.O. 1F-4C-2-16  
Change 6, March 1, 1974

REFERENCE DESIGNATOR  
22-B708

SUBSYSTEM  
AFCS

UNIT NOMENCLATURE  
STABILATOR FEEL TRIM ACTUATOR

DISCREPANCY:

Figure 4-2, and figure 4-3, both show two switches in the Stabilator Feel Trim Actuator (ref. des. 22-B708) labeled Nose Up Retract Limit and Nose Down Extend Limit respectively. They also show two actuator coils labeled similarly.

System Function and Characteristics, table 2-3 in T.O. 1F-4C-2-16 and the Stabilator Power Control Cylinder drawing in fig. 2-3 of T.O. 1F-4C-2-16 both show that the Stabilator Feel Trim Actuator must EXTEND to bring the Nose Up and RETRACT to bring the Nose Down.

ASSUMED CORRECTION:

The Nose Up Retract Limit Switch should be relabeled:  
Nose Up Extend Limit.

The Nose Up Retract coil should be relabeled:  
Nose Up Extend.

The Nose Down Extend Limit Switch should be relabeled:  
Nose Down Retract Limit.

The Nose Down Extend coil should be relabeled:

Nose Down Retract

REPORTED BY Robert Clardy Robert Cloudes DATE 7/26/74

SNEAK CIRCUIT GROUP ACTION BY Julius B Campbell DATE 7/29/74

CONTACT NAME \_\_\_\_\_ DATE \_\_\_\_\_

CONTRACTOR CONCURRENCE BY \_\_\_\_\_ DATE \_\_\_\_\_

D2-118545-1

SNEAK CIRCUIT DRAWING ERROR REPORT

F-4C-12

TO: Earl Parker

PROJECT: F-4C

DOCUMENT NO. T.O. 1F-4C-2-4  
Change 8, Febraury 15, 1974

REFERENCE DESIGNATOR  
22-B708

SUBSYSTEM  
AFCS

UNIT NOMENCLATURE  
STABILATOR FEEL TRIM ACTUATOR

DISCREPANCY:

Figure 3-2 shows two switches in the Stabilator Feel Trim Actuator (ref. des. 22-B708) labeled Nose Up Retract Limit and Nose Down Extend Limit respectively.

System Function and Characteristics, table 2-3 in T.O. 1F-4C-2-16 and the Stabilator Power Control Cylinder drawing in Fig. 2-13 in T.O. 1F-4C-2-16 both show that the Stabilator Feel Trim Actuator must EXTEND to bring the Nose Up and Retract to bring the Nose Down.

ASSUMED CORRECTION:

The Nose Up Retract Limit Switch should be relabeled:  
Nose Up Extend Limit.

The Nose Down Extend Limit Switch should be relabeled:  
Nose Down Retract Limit.

REPORTED BY Robert Clardy *Robert Clardy* DATE 7/26/74

SNEAK CIRCUIT GROUP ACTION BY Julius B Campbell DATE 7/29/74

CONTACT NAME \_\_\_\_\_ DATE \_\_\_\_\_

CONTRACTOR CONCURRENCE BY \_\_\_\_\_ DATE \_\_\_\_\_

TO: Earl Parker

PROJECT: F-4C

DOCUMENT NO. T.O. 1F-4C-2-23  
Change 13, March 15, 1974

REFERENCE DESIGNATOR  
22-B708

SUBSYSTEM  
AFCS

UNIT NOMENCLATURE  
STABILATOR FEEL TRIM ACTUATOR

DISCREPANCY:

Figure 3-2 and figure 3-55 both show two switches in the Stabilator Feel Trim Actuator (ref.des. 22-B708) labeled Nose Up Retract Limit and Nose Down Extend Limit respectively.

SYSTEM FUNCTION and CHARACTERISTICS, table 2-3 in T.O. 1F-4C-2-16 and the Stabilator Power Control Cylinder drawing in Fig. 2-13 in T.O. 1F-4C-2-16 both show that the Stabilator Feel Trim Actuator must EXTEND to bring the Nose Up and RETRACT to bring the Nose Down.

ASSUMED CORRECTION:

The Nose Up Retract Limit Switch should be relabeled:  
Nose Up Extend Limit.

The Nose Down Extend Limit Switch should be relabeled:  
Nose Down Retract Limit.

REPORTED BY Robert Clardy Robert Clardy DATE 7/26/74

SNEAK CIRCUIT GROUP ACTION BY Julius B. Campbell DATE 7/29/74

CONTACT NAME \_\_\_\_\_ DATE \_\_\_\_\_

CONTRACTOR CONCURRENCE BY \_\_\_\_\_ DATE \_\_\_\_\_

# SNEAK CIRCUIT DRAWING ERROR REPORT

F-4C-14

TO: DOC ENT NO. T.O. 1F-4C-2-12	PROJECT: F-4C REFERENCE DESIGNATOR 71Z311	SUBSYSTEM AFCS
---------------------------------------	---	-------------------

UNIT NOMENCLATURE  
 Air Data Computer

**DISCREPANCY:**

T.O. 1F-4C-2-12, Figure 2-6, Sheet 1, Change 7, designates pins 47 & 48 of connector J1 as 28 VDC Mach Hold Engage and Pin 49 as 28 VDC Alt Hold Engage. This is not in agreement with T.O. 1F-4C-2-16, Figure 2-36, Sheet 4, Change 5.

**ASSUMED CORRECTION:**

T.O. 1F-4C-2-12, Figure 2-6, Sheet 1, should be changed to show 28 VDC Alt Hold Engage at Pins 47 & 48 of Connector J1 and 28 VDC Mach Hold Engage at Pin 49 of Connector J1.

REPORTED BY DC Self  
 D. C. Self DATE 8/16/74

SNEAK CIRCUIT GROUP ACTION BY P. J. Stokes  
 for J. B. Campbell DATE 8/16/74

CONTACT NAME \_\_\_\_\_ DATE \_\_\_\_\_

CONTRACTOR CONCURRENCE BY \_\_\_\_\_ DATE \_\_\_\_\_

SNEAK CIRCUIT DRAWING ERROR REPORT F-4C-15

TO: Earl Parker

PROJECT: F-4C

DOCUMENT NO. 7327660, Sheet 2	REFERENCE DESIGNATOR Wiring Diagrams	SUBSYSTEM AFCS
----------------------------------	---	-------------------

TIT NOMENCLATURE

Automatic Flight Control System Circuit

DISCREPANCY;

Connector 65P318 pin E is shown wired to connector 65P/J717 pin E and then to connector 65P/J716 pin M. Figure 3-102 of T.O. 1F-4C-2-23 shows 65P318 pin E wired to 65P/J717 pin E and then to 65P/J716 pin M.

ASSUMED CORRECTION:

Change pin E of connector 65P/J717 to pin E.

REPORTED BY Robert Clardy *Robert Clardy* DATE 9-9-74

SNEAK CIRCUIT GROUP ACTION BY P. F. Stokes *P. F. Stokes* DATE 9-12-74

CONTACT NAME \_\_\_\_\_ DATE \_\_\_\_\_

CONTRACTOR CONCURRENCE BY \_\_\_\_\_ DATE \_\_\_\_\_

D2-118545-1

# SNEAK CIRCUIT DRAWING ERROR REPORT F-4C-16

TO: Earl Parker

PROJECT: F-4C

DOCUMENT NO. 7327681	REFERENCE DESIGNATOR 65-2208	SUBSYSTEM AFCS
-------------------------	---------------------------------	-------------------

**JIT NOMENCLATURE**

Controller Assy - Automatic Pilot Engaging

**DISCREPANCY:**

Power is shown being fed to switches S101, S105, and S104 of the Engaging Controller from connector J101 pin H. In drawings 702C187, Revision C, and 281E402, Rev. B, power is shown being fed by J101 pin h.

**ASSUMED CORRECTION:**

Change pin H of connector J101 to h in the two locations that it appears on Dwg. 7327681.

REPORTED BY Robert Clardy *Robert Clardy* DATE 9-9-74

SNEAK CIRCUIT GROUP ACTION BY P. F. Stokes *P. F. Stokes* DATE 9-12-74

CONTACT NAME \_\_\_\_\_ DATE \_\_\_\_\_

CONTRACTOR CONCURRENCE BY \_\_\_\_\_ DATE \_\_\_\_\_

AV-4471

D2-118545-1

APPENDIX D

MATRIX - COMPONENT FAILURE vs. AIRCRAFT EFFECT

FAILED COMPONENT LOCATION	COMPONENT SYMBOL	REFERENCE DRAWING	AIRCRAFT EFFECT	INVESTIGATION REPORT	RELATED DESIGN CONCERN REPORT
CHASSIS	CR50, CR51 CR52	T.O. 5A1-2-42-2 Figure 5-6 - Sheet 2	Total Loss of Autopilot power. Aircraft must be manually controlled.	F-4C-1	F-4C-7 F-4C-14
	R50	T.O. 5A1-2-42-2 Figure 5-6 Sheet 2	Loss of pitch and roll fader effect. Autopilot will oppose pilot controlled pitch and roll maneuvers.	F-4C-2	F-4C-14
	K9A	T.O. 5A1-2-42-2 Figure 5-6 Sheets 3 & 5	Autopilot will be unable to maintain heading hold and/or roll attitude depending on contact failure.	F-4C-3	N/A
	C50	T.O. 5A1-2-42-2 Figure 5-6 Sheet 2	Loss of pitch and roll fader effect. Autopilot will oppose pilot controlled pitch and roll maneuvers.	F-4C-1 F-4C-2	F-4C-7 F-4C-9 F-4C-14
	C51	T.O. 5A1-2-42-2 Figure 5-6 Sheet 2	AFCS cannot be engaged. If failure occurs after AFCS engagement, altitude hold is engaged.	F-4C-1 F-4C-4	F-4C-7 F-4C-14
	C4A	T.O. 5A1-2-42-2 Figure 5-6 Sheet 2	Loss of pitch and roll channels of the autopilot.	F-4C-5	F-4C-10
	C4B	T.O. 5A1-2-42-2 Figure 5-6 Sheet 2	Loss of pitch and roll channels of the autopilot.	F-4C-6	F-4C-10
	C4C	T.O. 5A1-2-42-2 Figure 5-6 Sheet 2	Loss of yaw, roll and most of pitch channels of the autopilot.	F-4C-7	F-4C-10
	C400, C401	T.O. 5A1-2-42-2 Figure 5-6 Sheet 5	Loss of roll fader effect. Autopilot will oppose pilot controlled roll maneuvers.	F-4C-2	F-4C-8
	C103A	T.O. 5A1-2-42-2 Figure 5-6 Sheet 4	Aircraft pitches down.	F-4C-8	F-4C-11
	C103B	T.O. 5A1-2-42-2 Figure 5-6 Sheet 4	Aircraft pitches up.	F-4C-8	F-4C-11
	C202A	T.O. 5A1-2-42-2 Figure 5-6 Sheet 5	Aircraft rolls right.	F-4C-8	F-4C-11
	C202B	T.O. 5A1-2-42-2 Figure 5-6 Sheet 5	Aircraft rolls left.	F-4C-8	F-4C-11
	C203A	T.O. 5A1-2-42-2 Figure 5-6 Sheet 5	Aircraft rolls left.	F-4C-8	F-4C-11
C203B	T.O. 5A1-2-42-2 Figure 5-6 Sheet 5	Aircraft rolls right.	F-4C-8	F-4C-11	
C302A	T.O. 5A1-2-42-2 Figure 5-6 Sheet 6	Aircraft yaws left.	F-4C-8	F-4C-11	

MATRIX - COMPONENT FAILURE vs. AIRCRAFT EFFECT

FAILED COMPONENT LOCATION	COMPONENT SYMBOL	REFERENCE DRAWING	AIRCRAFT EFFECT	INVESTIGATION REPORT	RELATED DESIGN CONCERN REPORT
CHASSIS	C302B	T.O. 5A1-2-42-2 Figure 5-6 Sheet 6	Aircraft yaws right.	F-4C-8	F-4C-11
	CR53, CR54 CR55, CR13A CR14A	T.O. 5A1-2-42-2 Figure 5-6 Sheet 2	AFCS disengages. Aircraft must be manually controlled.	F-4C-9	F-4C-13
ADDER ATTENUATOR	C3	T.O. 5A1-2-42-2 Figure 3-3 Fig. 5-6, Sh. 4, 5	Loss of roll fader effect. Autopilot will oppose pilot controlled roll maneuvers.	F-4C-2	F-4C-12
	C23	T.O. 5A1-2-42-2 Figure 3-3, Fig. 5-6, Sh. 4, 5	Loss of pitch fader effect. Autopilot will oppose pilot controlled pitch maneuvers.	F-4C-1 F-4C-2	F-4C-7 F-4C-12
PITCH CANCELLER	CR10	T.O. 5A1-2-42-2 Figure 3-3, Fig. 5-6, Sh. 4, 5	If AFCS engaged, autopilot switches to altitude hold. If AFCS not engaged, sudden pitch deviations occur when it is engaged.	F-4C-10	N/A
	C1	T.O. 5A1-2-42-2 Figure 3-4 Fig. 5-6, Sh. 4	Rate Gyro will not compensate for aircraft pitch oscillations.	F-4C-11 F-4C-12	F-4C-12
YAW CANCELLER	C1	T.O. 5A1-2-42-2 Figure 3-4 Fig. 5-6, Sh. 6	Rate Gyro will not compensate for aircraft yaw oscillations.	F-4C-11 F-4C-12	F-4C-12
	COURSE SYNC DRIVE AMPLIFIER	C6	T.O. 5A1-2-42-2 Figure 3-6, Fig. 5-6, Sh. 5	When AFCS is engaged aircraft will attempt to assume last heading held prior to failure. If AFCS engaged autopilot will hold present heading.	F-4C-13 F-4C-14
C7		T.O. 5A1-2-42-2 Figure 3-6, Fig. 5-6, Sh. 5	When AFCS is engaged aircraft will attempt to assume last heading held prior to failure. If AFCS engaged autopilot will hold present heading.	F-4C-13 F-4C-14	F-4C-12
PITCH FOLLOWUP CANCELLER SYNC DRIVE AMPLIFIER	CR2, CR3 CR4, CR5	T.O. 5A1-2-42-2 Figure 3-6, Fig. 5-6, Sh. 5	When AFCS is engaged aircraft will attempt to assume last heading held prior to failure. If AFCS engaged autopilot will hold present heading.	F-4C-13 F-4C-14	N/A
	C6	T.O. 5A1-2-42-2 Figure 3-6, Fig. 5-6, Sh. 4	Autopilot cannot maintain pitch attitude.	F-4C-13 F-4C-15	F-4C-12
PITCH SYNC DRIVE AMPLIFIER	C7	T.O. 5A1-2-42-2 Figure 3-6, Fig. 5-6, Sh. 4	Autopilot cannot maintain pitch attitude.	F-4C-13 F-4C-15	F-4C-12
	CR2, CR3 CR4, CR5	T.O. 5A1-2-42-2 Figure 3-6 Fig. 5-6, Sh. 4	Autopilot cannot maintain pitch attitude.	F-4C-13 F-4C-15	N/A
PITCH SYNC DRIVE AMPLIFIER	C6	T.O. 5A1-2-42-2 Figure 3-6 Fig. 5-6, Sh. 4	If AFCS engaged autopilot will maintain pitch attitude. If AFCS not engaged, aircraft must assume pitch attitude at time of failure before AFCS can be engaged.	F-4C-13 F-4C-16	F-4C-12
	C7	T.O. 5A1-2-42-2 Figure 3-6 Fig. 5-6, Sh. 4	If AFCS engaged autopilot will maintain pitch attitude. If AFCS not engaged, aircraft must assume pitch attitude at time of failure before AFCS can be engaged.	F-4C-13 F-4C-16	F-4C-12

FAILED COMPONENT LOCATION	COMPONENT SYMBOL	REFERENCE DRAWING	AIRCRAFT EFFECT	INVESTIGATION REPORT	RELATED DESIGN CONCERN REPORT
PITCH SYNC DRIVE AMP	CR2, CR3 CP4, CR5	T.O. 5A1-2-42-2 Figure 3-6, Fig. 5-6, Sh. 4	If AFCS engaged autopilot will maintain pitch attitude. If AFCS not engaged, aircraft must assume pitch attitude at time of failure before AFCS can be engaged.	F-4C-13 F-4C-16	N/A
		T.O. 5A1-2-42-2 Figure 3-6, Fig. 5-6, Sh. 5	When AFCS is engaged aircraft will attempt to assume roll attitude held prior to failure. If AFCS engaged, autopilot will hold present roll attitude.	F-4C-13 F-4C-14	F-4C-12
ROLL SYNC DRIVE AMPLIFIER	C6	T.O. 5A1-2-42-2 Figure 3-6, Fig. 5-6, Sh. 5	When AFCS is engaged aircraft will attempt to assume roll attitude held prior to failure. If AFCS engaged, autopilot will hold present roll attitude.	F-4C-13 F-4C-14	F-4C-12
		T.O. 5A1-2-42-2 Figure 3-6, Fig. 5-6, Sh. 5	When AFCS is engaged aircraft will attempt to assume roll attitude held prior to failure. If AFCS engaged, autopilot will hold present roll attitude.	F-4C-13 F-4C-14	N/A
PITCH SERVO AMPLIFIER	CR2, CR3 CR4, CR5	T.O. 5A1-2-42-2 Figure 3-6, Figure 5-6, Sh. 5	When AFCS is engaged aircraft will attempt to assume roll attitude held prior to failure. If AFCS engaged, autopilot will hold present roll attitude.	F-4C-13 F-4C-14	N/A
		T.O. 5A1-2-42-2 Figure 3-5, Figure 5-6, Sh. 4	Loss of autopilot control over stabilator movement.	F-4C-17	F-4C-12
PITCH SERVO AMPLIFIER	C2	T.O. 5A1-2-42-2 Figure 3-5, Figure 5-6, Sh. 4	Loss of autopilot control over stabilator movement.	F-4C-17	F-4C-12
		T.O. 5A1-2-42-2 Figure 3-5	Slow stabilator response to autopilot signals.	F-4C-18	N/A
LEFT ROLL SERVO AMPLIFIER	C9	T.O. 5A1-2-42-2 Figure 3-5, Figure 5-6, Sh. 4	Loss of autopilot control over stabilator movement.	F-4C-17	F-4C-12
		T.O. 5A1-2-42-2 Figure 3-5	Loss of autopilot control over left aileron and spoilers movement.	F-4C-17	F-4C-12
LEFT ROLL SERVO AMPLIFIER	C2	T.O. 5A1-2-42-2 Figure 3-5, Figure 5-6, Sh. 5	Loss of autopilot control over left aileron and spoilers movement.	F-4C-17	F-4C-12
		T.O. 5A1-2-42-2 Figure 3-5	Loss of autopilot control over left aileron and spoilers movement.	F-4C-17	F-4C-12
RIGHT ROLL SERVO AMPLIFIER	C3	T.O. 5A1-2-42-2 Figure 3-5, Figure 5-6, Sh. 5	Loss of autopilot control over left aileron and spoilers movement.	F-4C-17	F-4C-12
		T.O. 5A1-2-42-2 Figure 3-5	Slow left aileron and spoilers response to autopilot signals.	F-4C-18	N/A
RIGHT ROLL SERVO AMPLIFIER	C9	T.O. 5A1-2-42-2 Figure 3-5, Figure 5-6, Sh. 5	Loss of autopilot control over right aileron and spoilers movement.	F-4C-17	F-4C-12
		T.O. 5A1-2-42-2 Figure 3-5, Figure 5-6, Sh. 5	Loss of autopilot control over right aileron and spoilers movement.	F-4C-17	F-4C-12
YAW SERVO AMPLIFIER	C2	T.O. 5A1-2-42-2 Figure 3-5, Figure 5-6, Sh. 6	Loss of autopilot control over right aileron and spoilers movement.	F-4C-17	F-4C-12
		T.O. 5A1-2-42-2 Figure 3-5, Figure 5-6, Sh. 6	Loss of autopilot control over rudder movement.	F-4C-17	F-4C-12
YAW SERVO AMPLIFIER	C3	T.O. 5A1-2-42-2 Figure 3-5, Figure 5-6, Sh. 6	Loss of autopilot control over rudder movement.	F-4C-17	F-4C-12
		T.O. 5A1-2-42-2 Figure 3-5	Slow rudder response to autopilot signals.	F-4C-18	N/A

MATRIX - COMPONENT FAILURE VS. AIRCRAFT EFFECT

D2-118545-1

APPENDIX E  
INVESTIGATION REPORTS

D2-118545-1

ENGINEER Robert Clardy  
Robert Clardy

INVESTIGATION REPORT F-4C-1

If any of the diodes CR50, CR51, or CR52 in the Control Amplifier were to fail shorted then open, capacitors C50, C51, C158, and C23 may fail as described in Design Concern Report F-4C-7. For the effect each failure has on the aircraft, see the following Investigation Reports:

<u>Component</u>	<u>Investigation Report</u>
C50	F-4C-2
C51	F-4C-4
C158	F-4C-2
C23	F-4C-2

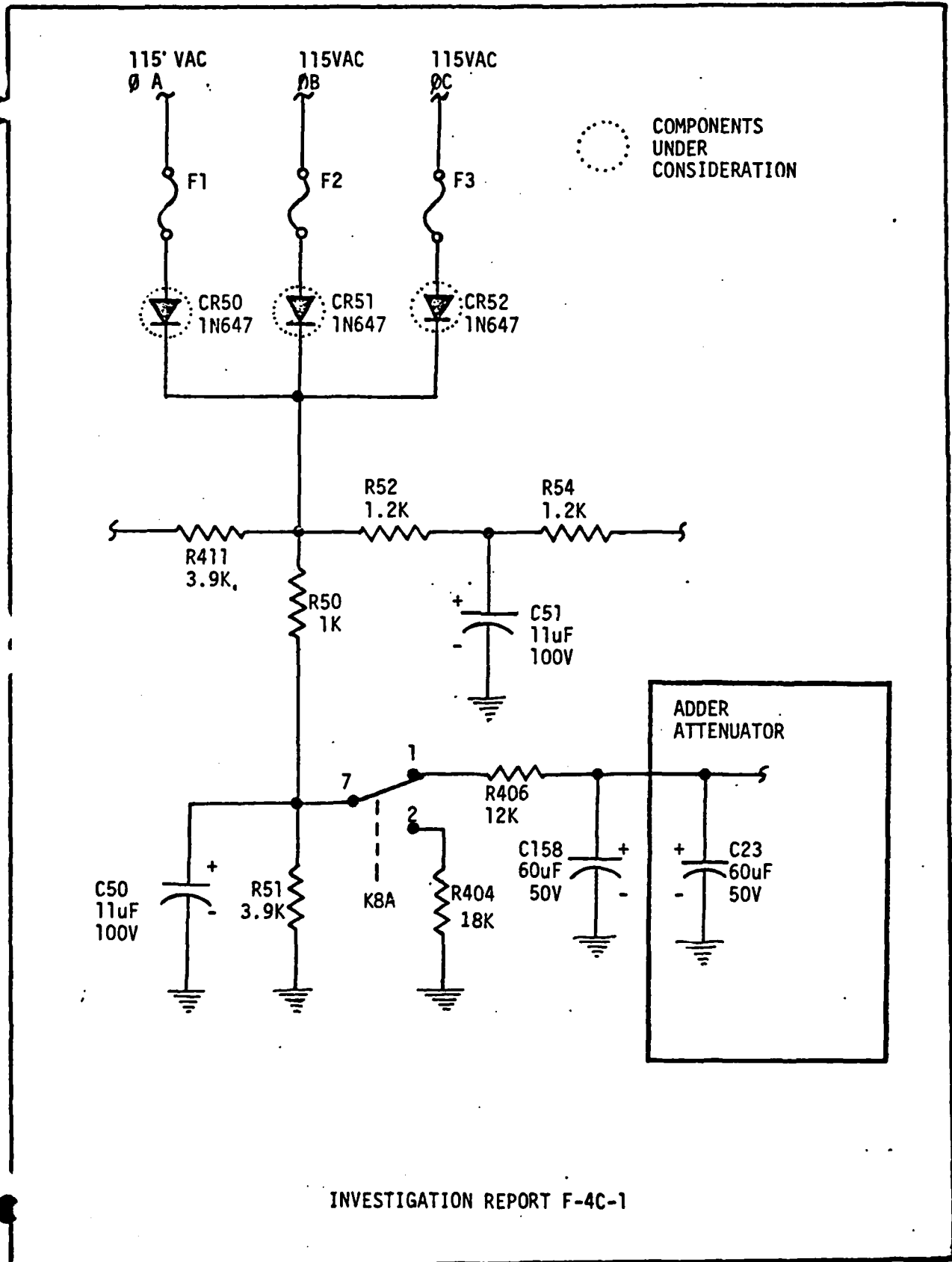

ENGINEER

*Robert Clardy*  
Robert Clardy

## INVESTIGATION REPORT F-4C-2

The Adder Attenuator is comprised of two similar amplifiers used to amplify signals in the pitch and roll autopilot channels.

The roll amplifier provides normal amplification of signals from the roll rate gyro and the displacement gyro. During pilot controlled maneuvers in the roll axis, the roll amplifier functions to fade the roll rate gyro signal to prevent this signal from opposing pilot controlled maneuvers. If capacitor C3 in the Adder Attenuator or capacitors C400 or C401 in the chassis wiring fail in the shorted mode, the fade effect of this channel will be inhibited. As a result the autopilot will oppose pilot controlled roll maneuvers.

The pitch amplifier provides normal amplification of signals from the CADC when in the altitude hold mode. When making transitions to and from the altitude hold mode this amplifier fades the altitude hold signal to assure a smooth transition. If capacitor C23 in the Adder Attenuator or capacitor C158 (C158 was not identified as a high failure item but is included here since it has the same effect as C23) in the chassis wiring fail in the shorted mode, the fade effect of this channel will be inhibited. Also, the error signal from the CADC will always be passed by the Adder Attenuator thus opposing pilot controlled pitch maneuvers.

If capacitor C50 in the chassis wiring fails in the shorted mode or if resistor R50 in the chassis wiring fails in the open mode the fade effect of both channels of the Adder Attenuator will be lost and the autopilot will oppose pilot controlled pitch and roll maneuvers.

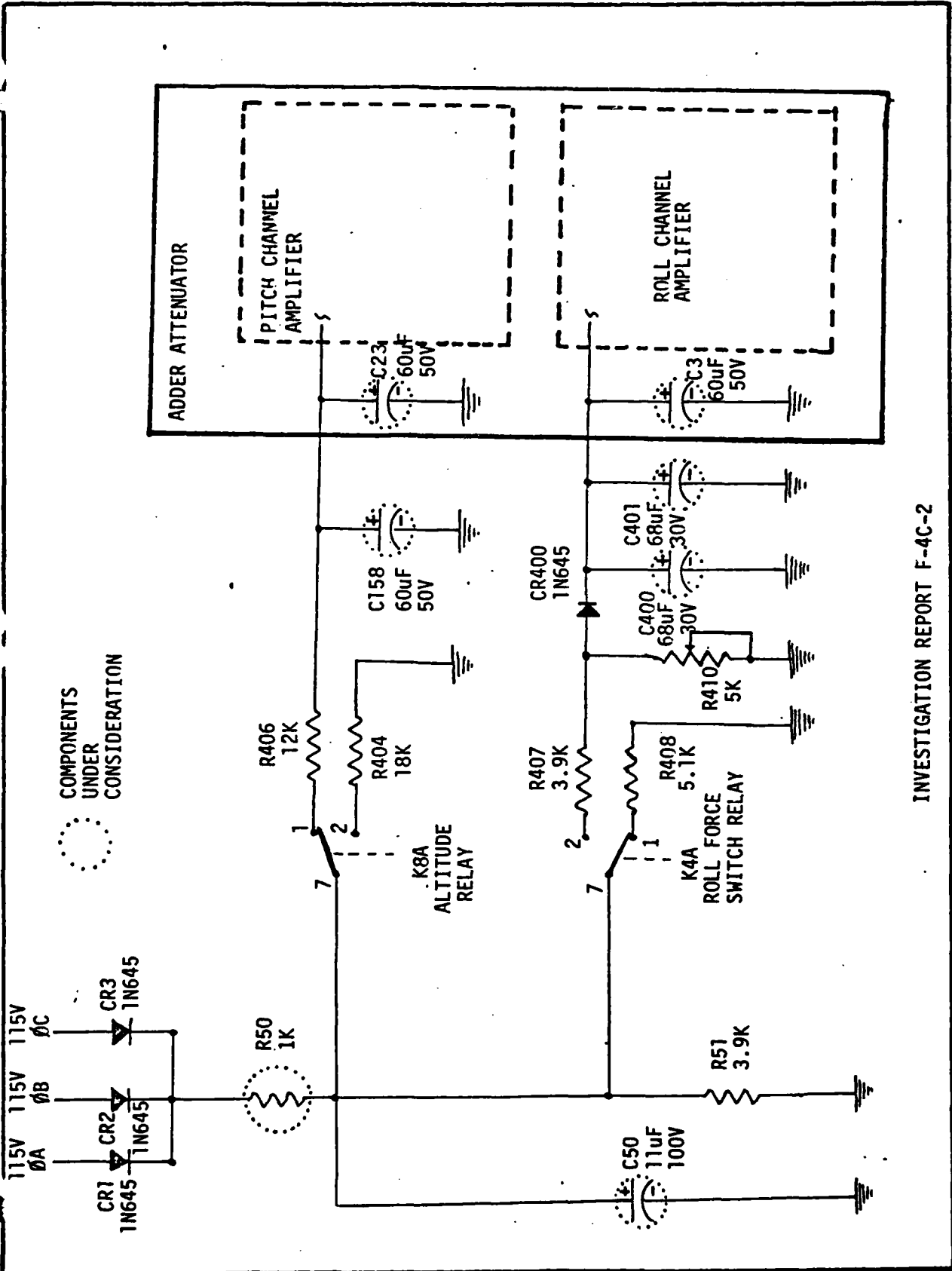

COMPONENTS  
UNDER  
CONSIDERATION

INVESTIGATION REPORT F-4C-2

ENGINEER

*Robert Clardy*  
Robert Clardy

## INVESTIGATION REPORT F-4C-3

The Roll Level Relay, K9A, is meant to prevent the establishment of the Heading Hold function of the autopilot when the aircraft is not level (within  $\pm 5^\circ$ ).

If the 1-7 contact of K9A hangs open (the 2-7 contact then being closed), power cannot be applied to the Roll Course Sync Relay (K25A) and the Roll Sync Brake (see figure 1). The Roll Sync Brake is used to establish a roll attitude for the autopilot. With it disabled, a bank angle cannot be maintained by the autopilot, however it can still hold the aircraft on a course heading.

If the 2-7 contact of K9A hangs open (the 1-7 contact then being closed), power cannot be applied to the Course Sync Brake (see figure 1). Therefore the established course cannot be maintained by the autopilot. The heading hold aspect of the AFCS is lost.

If the 3-5 contact of K9A hangs open (the 3-6 contact then being closed), the Roll Sync Drive control transformer is by-passed at all times, even when the Course Sync Drive is not operating (see figure 2). With it disabled, a bank angle cannot be maintained by the autopilot, however, it can still hold the aircraft on a course heading.

If the 3-6 contact of K9A hangs open (the 3-5 contact then being closed), the Roll Sync Drive control transformer cannot be by-passed (see figure 2). This would mean that with heading hold established, the Roll Sync Drive will still try to maintain its reference attitude. If the Course Sync Drive needs to adjust the ailerons to maintain the course heading, the Roll Sync Drive will oppose it, trying to maintain its reference attitude.

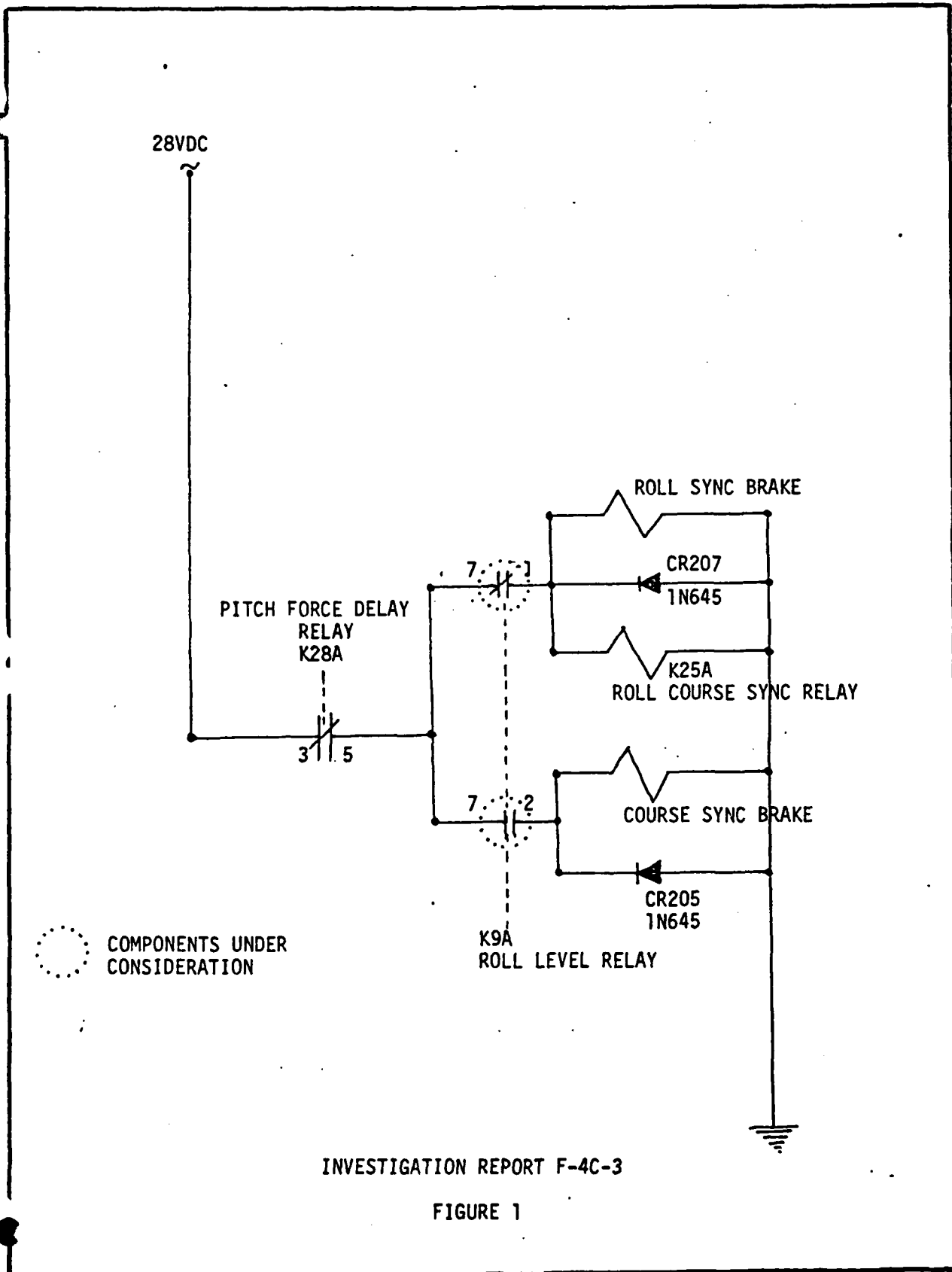

ROLL CHANNEL

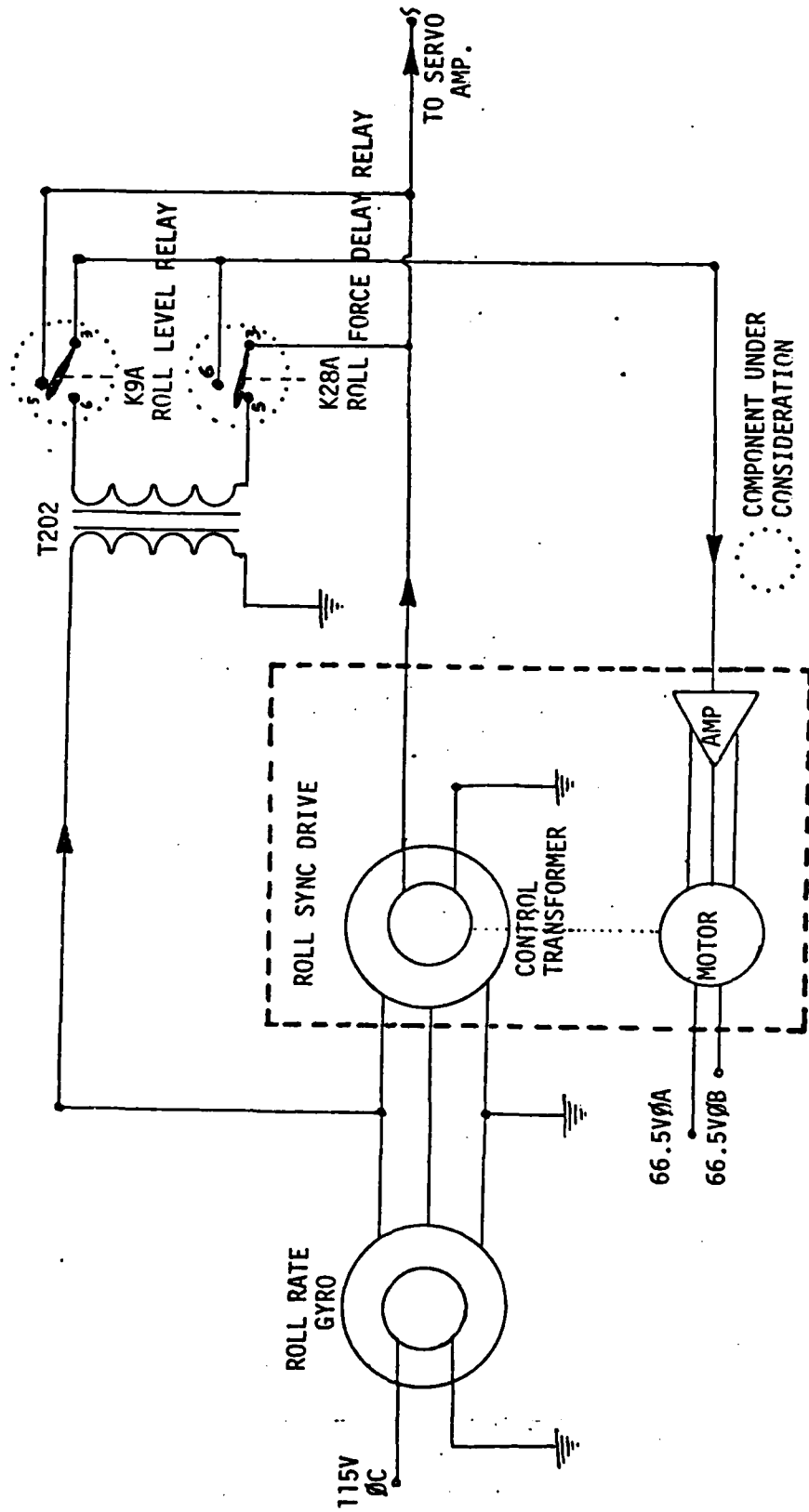

COMPONENT UNDER CONSIDERATION

INVESTIGATION REPORT F-4C-3

FIGURE 2

ENGINEER Robert Clardy  
Robert Clardy

## INVESTIGATION REPORT F-4C-4

Capacitor C51 is located in the B+ power supply circuitry of the Control Amplifier. If it fails shorted, the power supply for the Electronic Switch Monitor is shorted. The Electronic Switch Monitor is used to prevent AFCS engagement when a malfunction exists in the Pitch Sync Drive or Pitch Followup Canceller. With power to the Electronic Switch Monitor cut off, relays K3D and K3E lose their paths to ground, preventing AFCS engagement even when no malfunction exists in the pitch channel.

If C51 shorts while the AFCS is engaged, voltage to K20A is lost and it deenergizes, causing the Pitch Sync Brake to disengage and causing the Altitude Engage Clutch to engage. This has the effect of engaging altitude hold. The altitude of the aircraft at that time becomes the reference altitude for the altitude hold circuitry. This cannot be changed without disengaging the AFCS. Once disengaged, the AFCS cannot be reengaged.

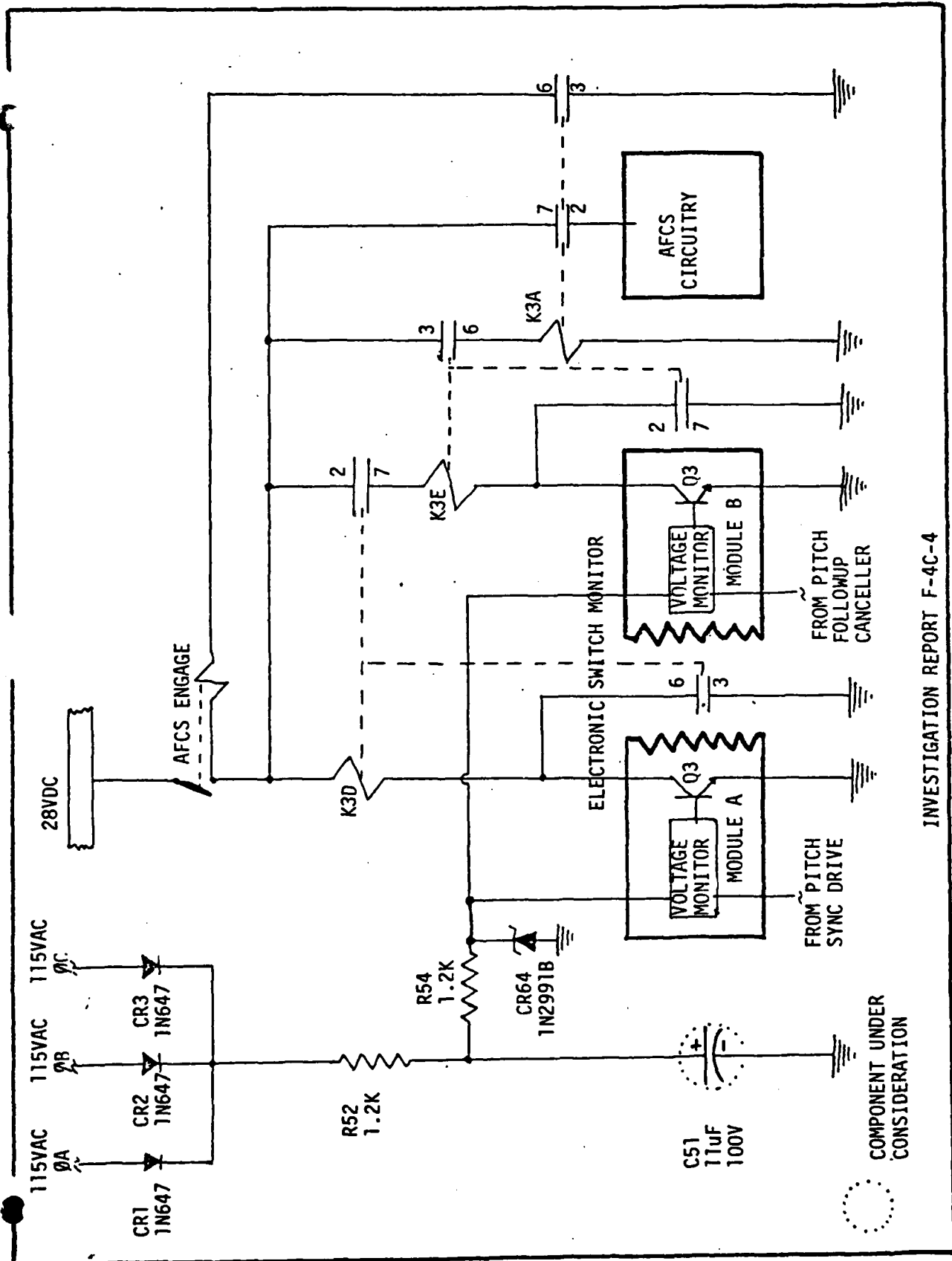

INVESTIGATION REPORT F-4C-4

ENGINEER

*Robert Clardy*  
Robert Clardy

## INVESTIGATION REPORT F-4C-5

Capacitor C4A is in the 115 VAC power supply circuitry of the Control Amplifier. If failed shorted, it will short out the 66.5V, 26V, 15V, and 8.7V phase A power sources for the Control Amplifier. This will cause the 3 amp fuse F1 to blow, cutting off all phase A power. If this occurs, the AFCS cannot be engaged. If the AFCS is engaged prior to the capacitor failure, the aircraft effects discussed below occur.

Phase A provides power for most of the pitch channel of the AFCS, including the Pitch Servo Amplifier. Loss of phase A will inactivate the autopilot's control of the stabilator.

Phase A also provides power for the fixed phase windings of the Roll Sync Drive Motor. The roll and course attitudes at the time of failure become the only attitudes that the AFCS can maintain. If a course or attitude change is required, AFCS must be disengaged.

Therefore, when C4A shorts, the pitch and roll channels of the AFCS are lost and the stabilator, ailerons, and spoilers must be manually controlled.

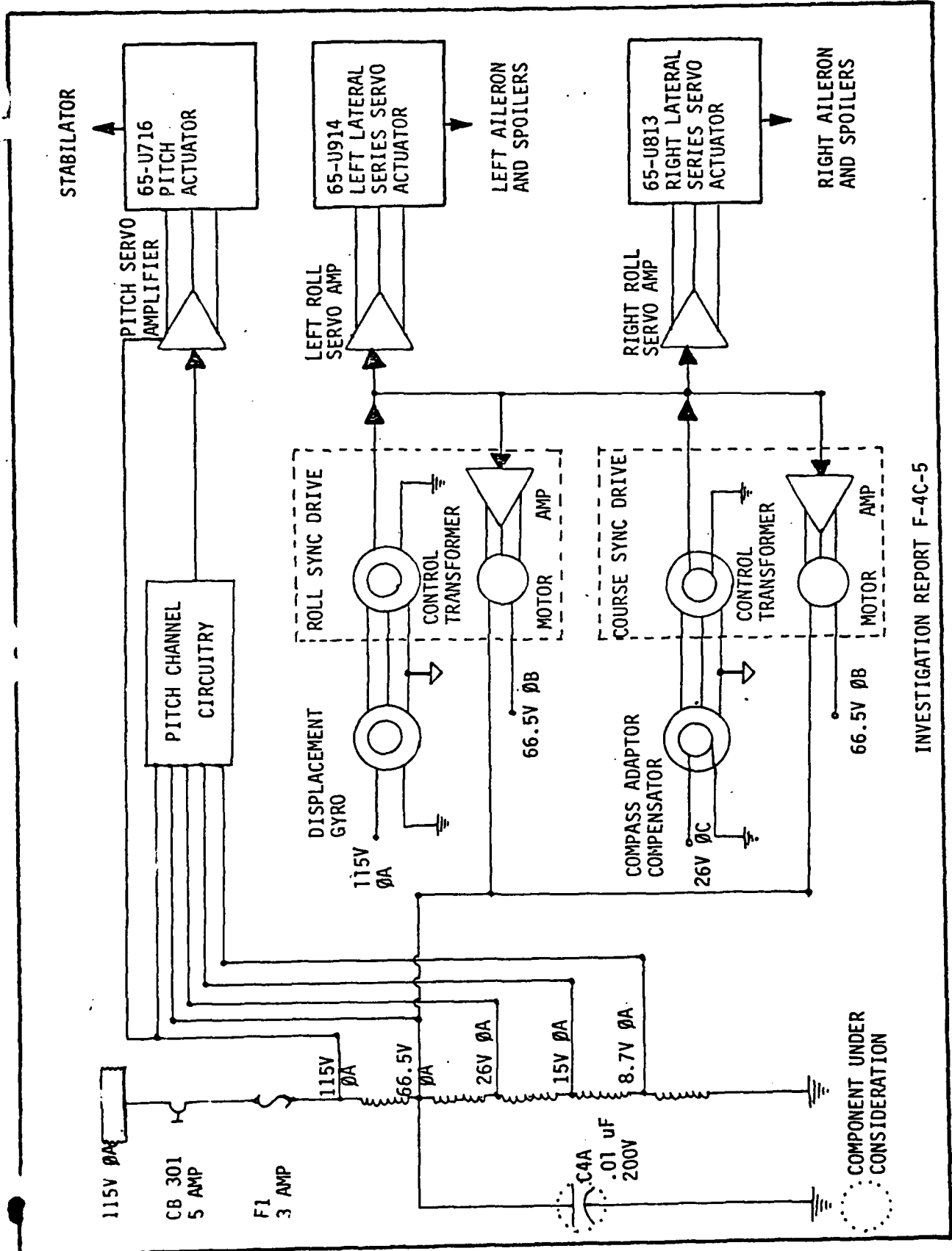

INVESTIGATION REPORT F-4C-5

ENGINEER

Robert Clardy  
Robert Clardy

## INVESTIGATION REPORT F-4C-6

Capacitor C4B is in the 115 VAC power supply circuitry of the Control Amplifier. If failed shorted, it will short out the 66.5V, 26V, 15V, and 8.7V phase B power sources for the Control Amplifier. This will cause the 3 amp fuse F2 to blow, cutting off all phase B power. If this occurs, the AFCS cannot be engaged. If the AFCS is engaged prior to the capacitor failure, the aircraft effects discussed below occur.

Phase B provides power to the fixed phase windings of the Pitch Sync Drive Motor, Pitch Follow-up Canceller Sync Drive Motor, Roll Sync Drive Motor, and the Course Sync Drive Motor. The last pitch, roll, and course attitudes established for the aircraft before the failure cannot be changed unless the AFCS is disengaged.

Therefore, when C4B shorts, the pitch and roll channels of the AFCS are lost and the stabilator, ailerons, and spoilers must be manually controlled.

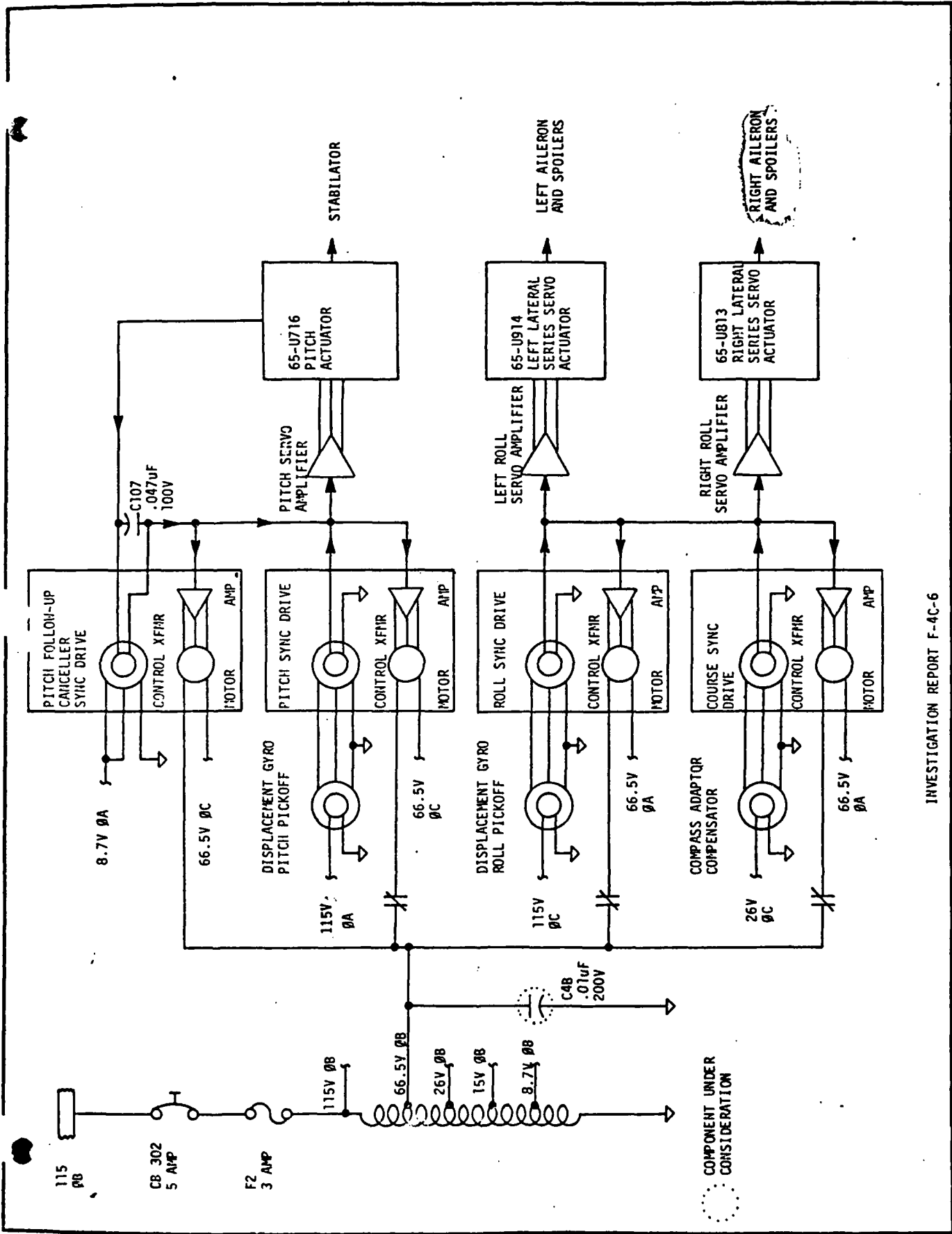

INVESTIGATION REPORT F-4C-6

ENGINEER

Robert Clardy  
Robert Clardy

## INVESTIGATION REPORT F-4C-7

Capacitor C4C is in the 115 VAC power supply circuitry of the Control Amplifier. If failed shorted, it will short out the 66.5V, 26V, 15V, and 8.7V phase C power sources for the AFCS. This will cause the 3 amp fuse F3 to blow, removing all phase C power.

Phase C provides power for most of the yaw and roll channels of the AFCS, including the Yaw Series Servo Amplifier and the Left and Right Roll Series Servo Amplifiers. Loss of phase C power will, therefore, disable the yaw and roll channels of the AFCS.

Phase C also provides power to the fixed phase windings of the Pitch Sync Drive and Pitch Follow-up Canceller Sync Drive motors. The pitch attitude at the time of capacitor C4C failure becomes the reference attitude for the pitch channel of the AFCS. If the aircraft is not at this attitude, the AFCS cannot be engaged. If it is, the AFCS can be engaged, but the attitude will not be maintained since the Pitch Follow-up Canceller Sync Drive will be unable to create artificial stabilator null positions to compensate for fuel consumption, stores release, etc. As these slow changes occur, the aircraft will gradually drift off its pitch reference attitude.

The result of a C4C capacitor failure is, therefore, total loss of the yaw and roll autopilot channels and for all practical purposes loss of the pitch autopilot channel.

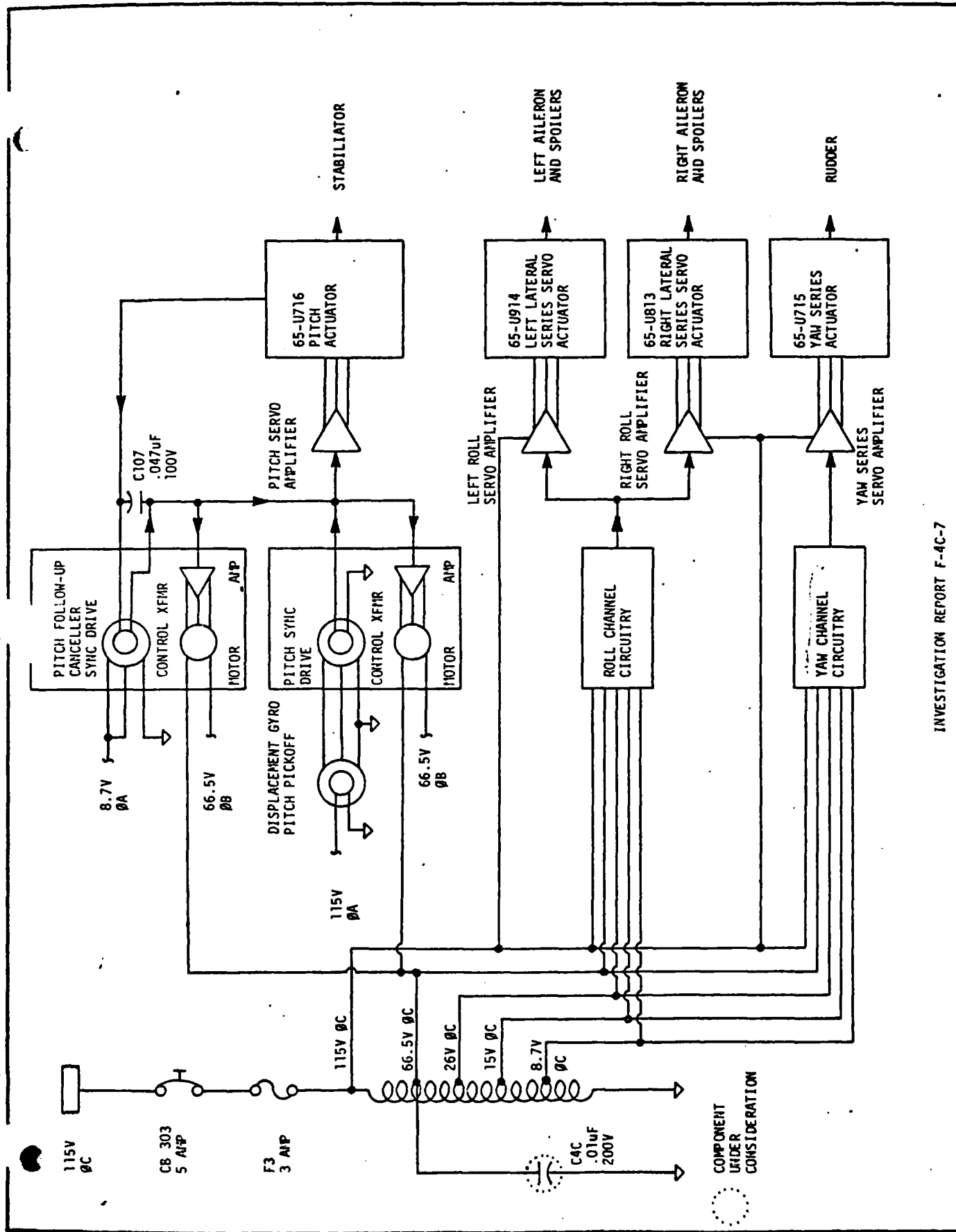

ENGINEER

*Robert Clardy*  
Robert Clardy

## INVESTIGATION REPORT F-4C-8

Capacitors C103A, C302A, C202B, and C203B shown in the attached figure are located across the outputs of the AFCS servo amplifiers. If one of them fails shorted, the extend coil of that channel's servo actuator is shorted. Since power is normally applied to both coils at all times, this would cause the actuator involved to be fully retracted once the balancing control of the extend coils is lost. The maximum deflection of the control surface involved will cause an extreme aircraft maneuver by the AFCS.

If capacitor C103A in the pitch channel fails shorted, it will short the extend coil of the Stabilator Actuator. This will cause the Stabilator Actuator to retract to its limit, moving the stabilator to the full leading edge up position, causing the aircraft to pitch down.

If capacitor C302A in the yaw channel fails shorted, it will short the extend coil of the Rudder Actuator. This will cause the Rudder Actuator to retract to its limit, moving the rudder to the full left rudder position, causing the aircraft to yaw left.

If capacitor C202B in the roll channel fails shorted, it will short the extend coil of the left Aileron Actuator. This will cause the Left Lateral Series Servo Actuator to retract to its limit, moving the left aileron and spoilers to the full up position, causing the aircraft to roll left.

If capacitor C203B in the roll channel fails shorted, it will short the extend coil of the Right Aileron Actuator. This will cause the Right Lateral Series Servo Actuator to retract to its limit, moving the right aileron and spoilers to the full up position causing the aircraft to roll right.

Capacitors C103B, C302B, C202A, and C203A shown in the attached figure are located across the retract coils of the Servo Actuators. If one of them shorts, the actuator involved is extended to its limit. The maximum deflection of the control surface involved will cause an extreme aircraft maneuver by the AFCS.

If capacitor C103B in the pitch channel fails shorted, it will short the retract coil of the Stabilator Actuator. This will cause the Stabilator Actuator to extend to its limit, moving the stabilator to the full leading edge down position, causing the aircraft to pitch up.

If capacitor C302B in the yaw channel fails shorted, it will short the retract coil of the Rudder Actuator. This will cause the Rudder Actuator to extend to its limit, moving the rudder to the full right rudder position, causing the aircraft to yaw right.

If capacitor C202A in the roll channel fails shorted, it will short the retract coil of the Left Aileron Actuator. This will cause the Left Lateral Series Servo Actuator to extend to its limit, moving the left aileron and spoilers to the full down position, causing the aircraft to roll right.

D2-118545-1

INVESTIGATION REPORT F-4C-8 (Continued)

If capacitor C203A in the roll channel fails shorted, it will short the retract coil of the Right Lateral Series Servo Actuator. This will cause the Right Aileron Actuator to extend to its limit, moving the right aileron and spoilers to the full down position, causing the aircraft to roll left.

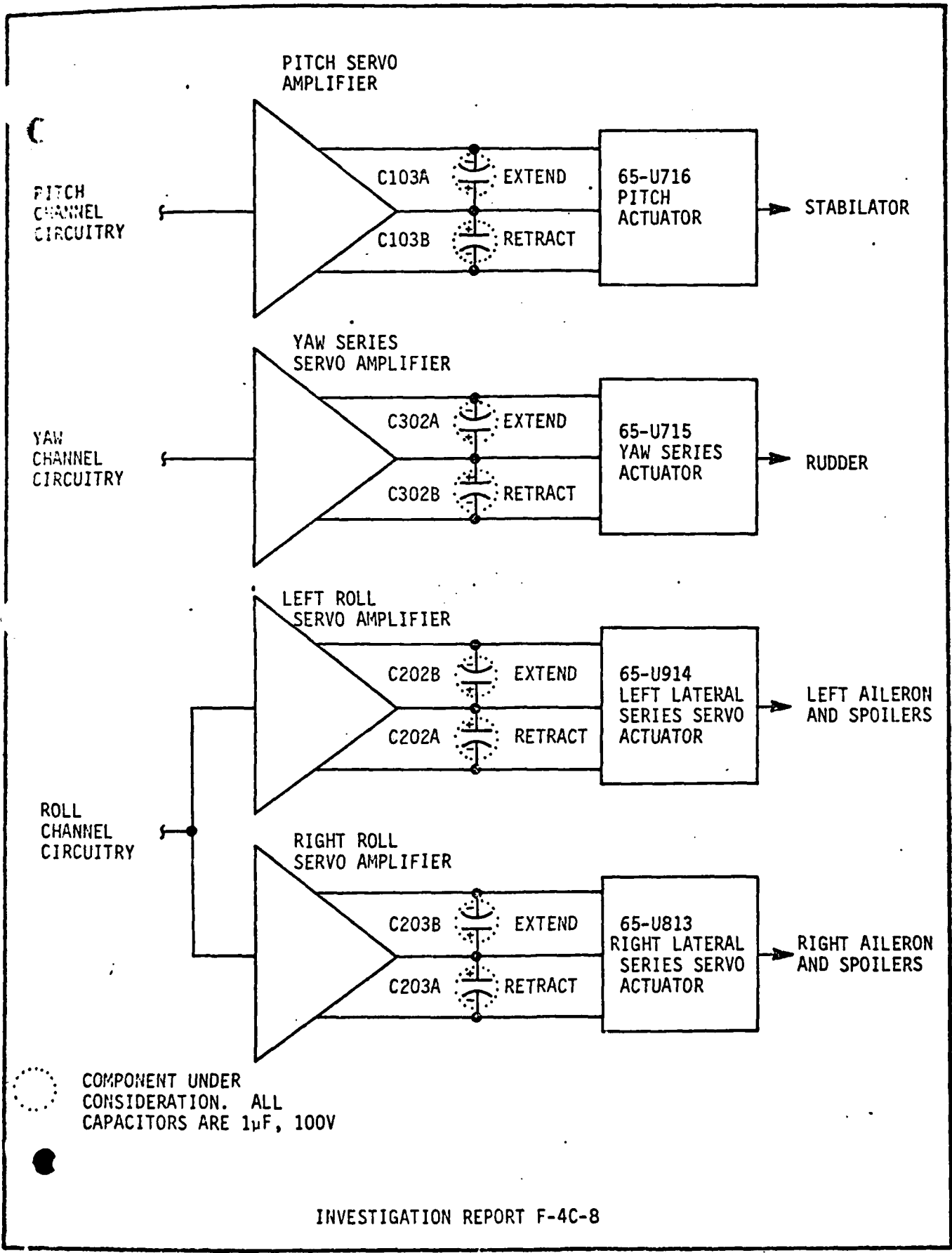

D2-118545-1

ENGINEER

P. F. Stokes  
P. F. Stokes

INVESTIGATION REPORT F-4C-9

If any of the diodes CR53, CR54, or CR55 in the chassis wiring fail in the shorted mode (then open) damage to diodes CR13A and CR14A will occur. Loss of CR53, CR54, or CR55 results in insufficient voltage being applied to relays K13A and K14A thus causing them to deenergize. When this occurs AFCS will be disengaged.

This failure mode applies to Control Amplifier, P/N 230E420G3, and earlier. This failure is discussed in greater detail in Design Concern Report F-4C-13.

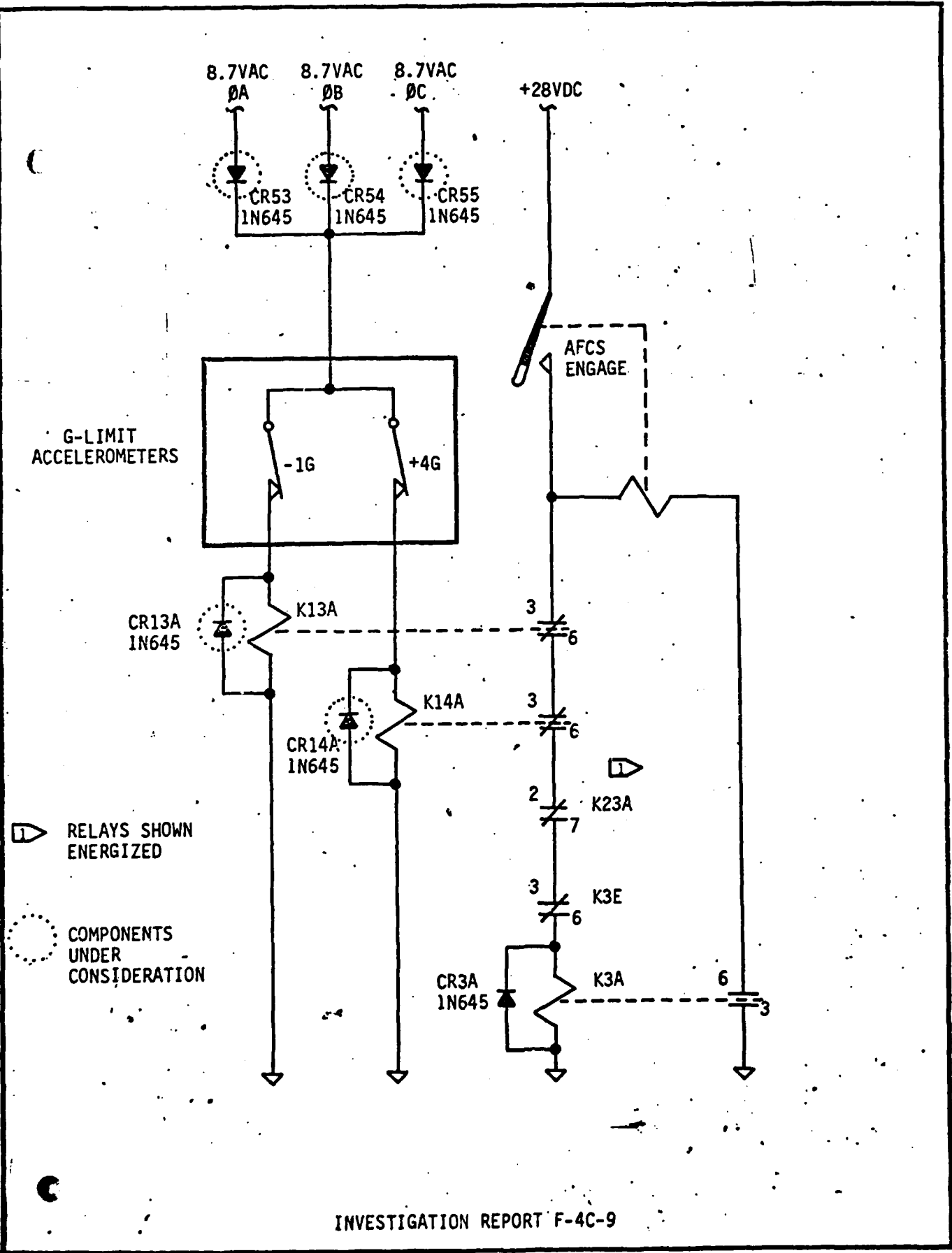

INVESTIGATION REPORT F-4C-9

ENGINEER

*Robert Clardy*  
Robert Clardy

## INVESTIGATION REPORT F-4C-10

Zener diode CR10, located in the pitch channel amplifier of the Adder Attenuator, is used to assure that relay K20A is energized or deenergized at the proper time to assure a smooth transition to and from the altitude hold mode. Relay K8A is normally in the position shown in the attached figure and capacitor C158 in the chassis wiring and C23 in the Adder Attenuator are charged to approximately 23 volts. When altitude hold is engaged, relay contacts K8A open.

The capacitors begin discharging through the resistors shown to ground. When the capacitor voltage drops below the zener voltage (20 volts) transistors Q3 and Q6 are turned off, thus deenergizing relay K20A. This in turn energizes the Altitude Engage Clutch and establishes a reference altitude. As the capacitors continue to discharge, the error signal from the Altitude Hold Synchro in the CADC is faded in assuring a smooth transition to the altitude hold mode. The reverse condition fades the error signal out prior to energizing relay K20A and switching back to the AFCS mode.

If CR10 fails shorted, the error signal from the Altitude Hold Synchro will be switched into the pitch channel of the AFCS rather than faded in. This occurs because transistors Q3 and Q6 will not be turned off, thus deenergizing K20A and energizing the Altitude Engage Clutch, until the capacitors have discharged to approximately 1 volt. By this time the gain of the Adder Attenuator will be at maximum. When the Altitude Engage Clutch is energized the error signal from the altitude hold synchro in the CADC will be fully amplified, rather than faded in, by the Adder Attenuator and Pitch Servo Amplifier. Aircraft motion resulting from this failure may be sudden pitch deviations depending on the error signal from the Altitude Hold Synchro.

If CR10 fails open, relay K20A cannot be energized. As a result a pitch attitude in the AFCS mode cannot be established since the Pitch Sync Drive is always nulled to the Vertical Gyro error signal. If the AFCS is engaged, altitude hold can be engaged and the altitude at which it was engaged will be held.

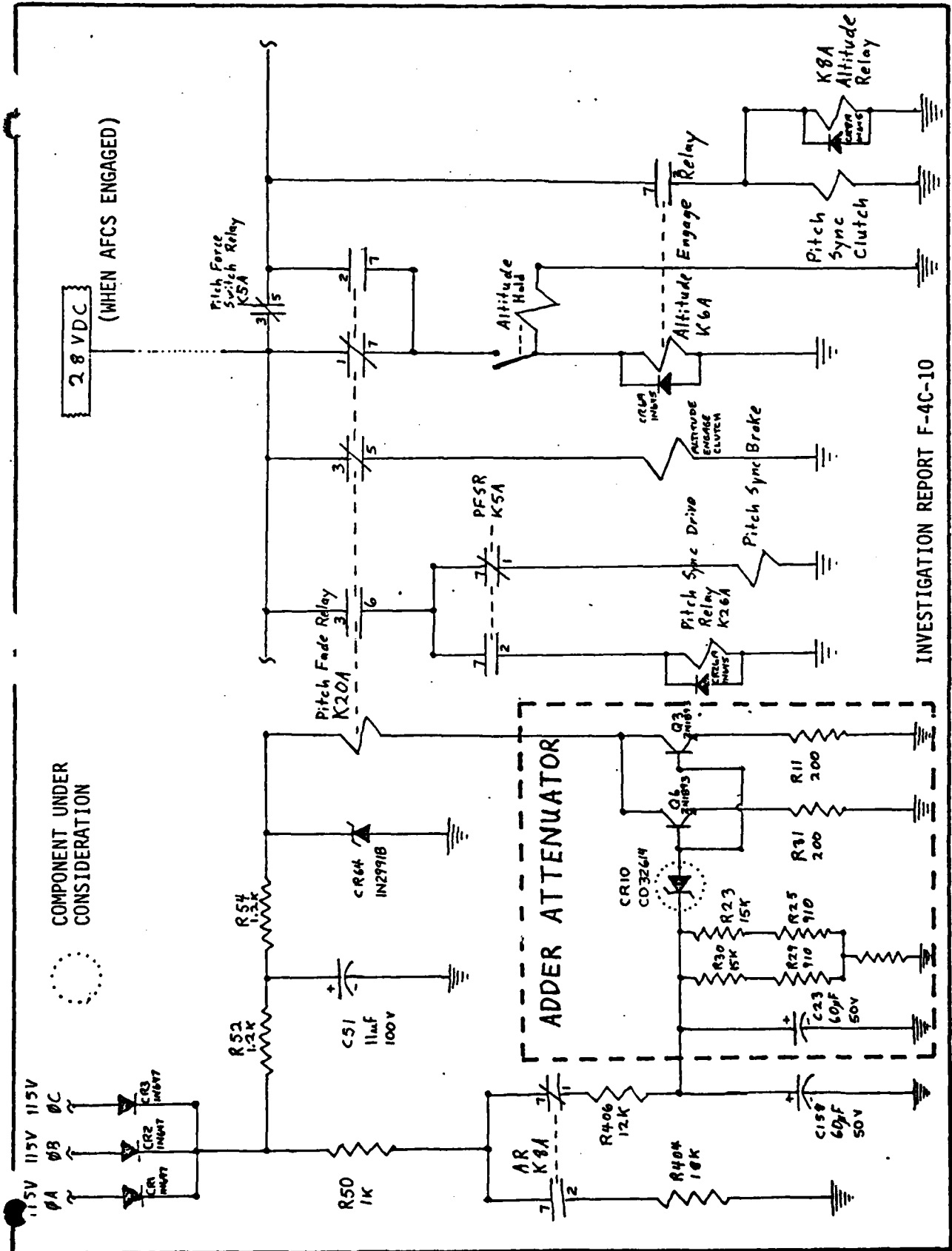

INVESTIGATION REPORT F-4C-10

COMPONENT UNDER CONSIDERATION

ENGINEER Gordon B. Buckley  
Gordon B. Buckley

INVESTIGATION REPORT F-4C-11

The canceller amplifier is a high pass filter. Pilot maneuvering produces steady state rate gyro outputs that are cancelled by the canceller amplifier rather than passed on to the servo amplifier. Therefore, the rate gyro will not oppose pilot control of attitude. Aircraft vibration oscillations produce high frequency signals that are amplified and passed on by the canceller amplifier.

If capacitor C1 fails shorted, the bias voltage for transistor Q1 is lost. This will inhibit all rate gyro signals from passing through the canceller amplifier. The effect this failure has on the aircraft is discussed in Investigation Report F-4C-12.

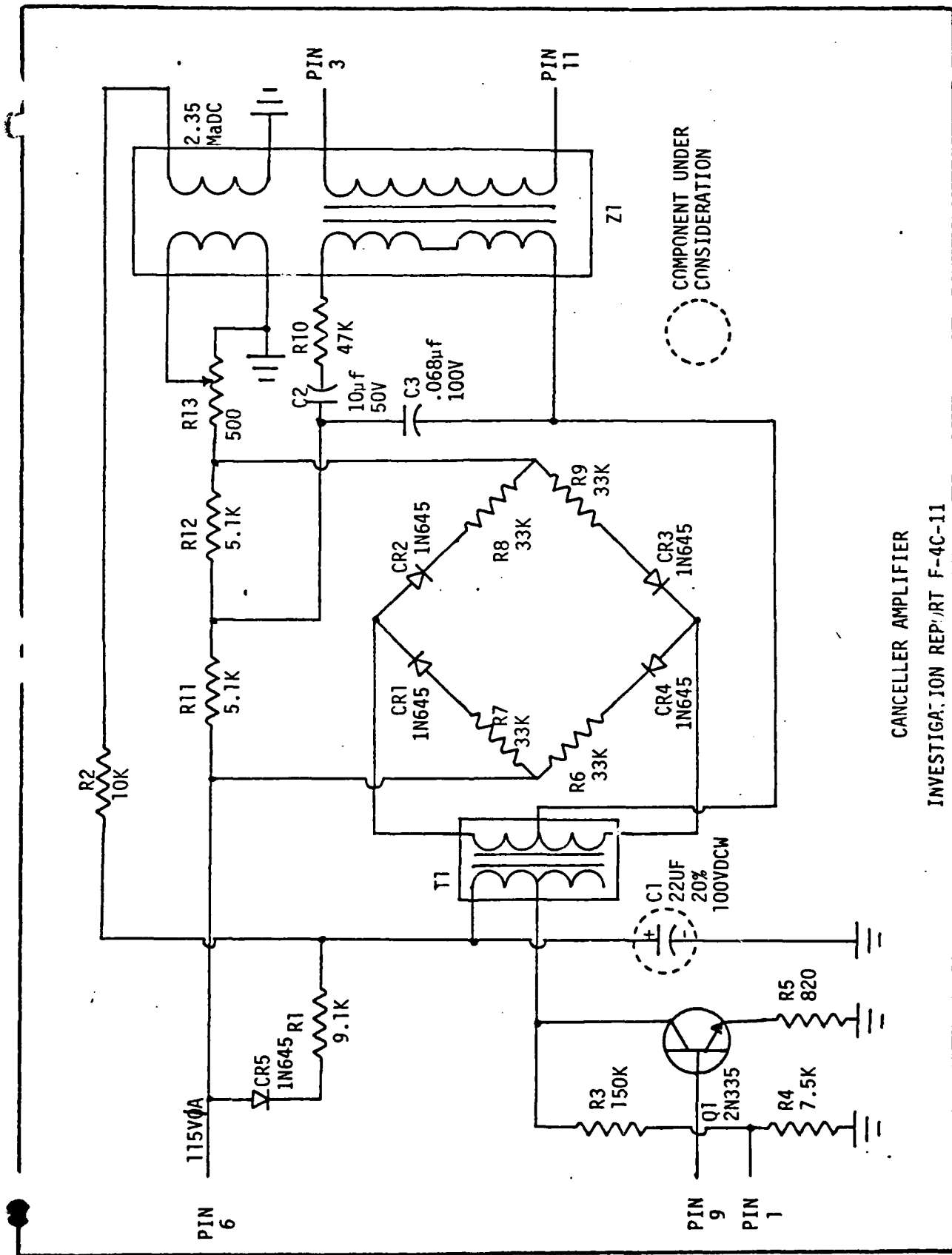

CANCELLER AMPLIFIER

INVESTIGATION REPORT F-4C-11

AD-A108 029

BOEING AEROSPACE CO HOUSTON TX SPACE DIV  
SNEAK CIRCUIT ANALYSIS OF F-4C FLIGHT CONTROL SYSTEM (U)  
SEP 74 P F STOKES  
D2-118545-1

F/G 17/7

F33657-74-C-0686

NL

UNCLASSIFIED

2 - 2

Pages



END
DATE
FILED
1 72
DTIC

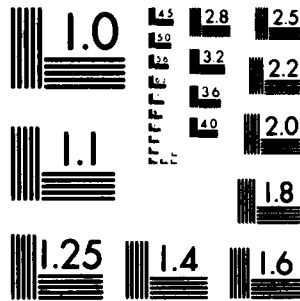

MICROCOPY RESOLUTION TEST CHART  
NATIONAL BUREAU OF STANDARDS 1963 A,

ENGINEER Gordon B. Buckley  
Gordon B. Buckley

## INVESTIGATION REPORT F-4C-12

Pitch Cancellor

The Pitch Rate Gyro (Ref. Des. 65-B909) is an error sensor and is aligned to the aircraft longitudinal axis. The Pitch Rate Gyro produces an error signal with amplitude proportional to deviation rate and phase corresponding to deviation direction.

The error signal from the Pitch Rate Gyro goes to the Pitch Cancellor. The signal from the Pitch Cancellor goes to the Pitch Servo Amplifier and to the CADC (Ref. Des. 71-Z311) for gain changing. The output signal of the CADC, goes to the Pitch Servo Amplifier. The Pitch Servo Amplifier controls stabilator movements.

With the Pitch Cancellor disabled as described in Investigation Report F-4C-11, the Pitch Rate Gyro Pickoff will have no affect on stabilator movement, thereby not being able to compensate for aircraft pitch oscillations.

Yaw Cancellor

The Yaw Rate Gyro (Ref. Des. 65-B810) is an error sensor and is aligned to the aircraft vertical axis. The Yaw Rate Gyro produces an error signal with amplitude proportional to deviation rate and phase corresponding to deviation direction.

The error signal from the Yaw Rate Gyro goes to the Yaw Cancellor. The signal from the Yaw Cancellor goes to the Yaw Servo Amplifier. The Yaw Servo Amplifier controls rudder movements.

With the Yaw Cancellor disabled as described in Investigation Report F-4C-11, the Yaw Rate Gyro Pickoff will have no affect on rudder movement, thereby not being able to compensate for aircraft yaw oscillations.

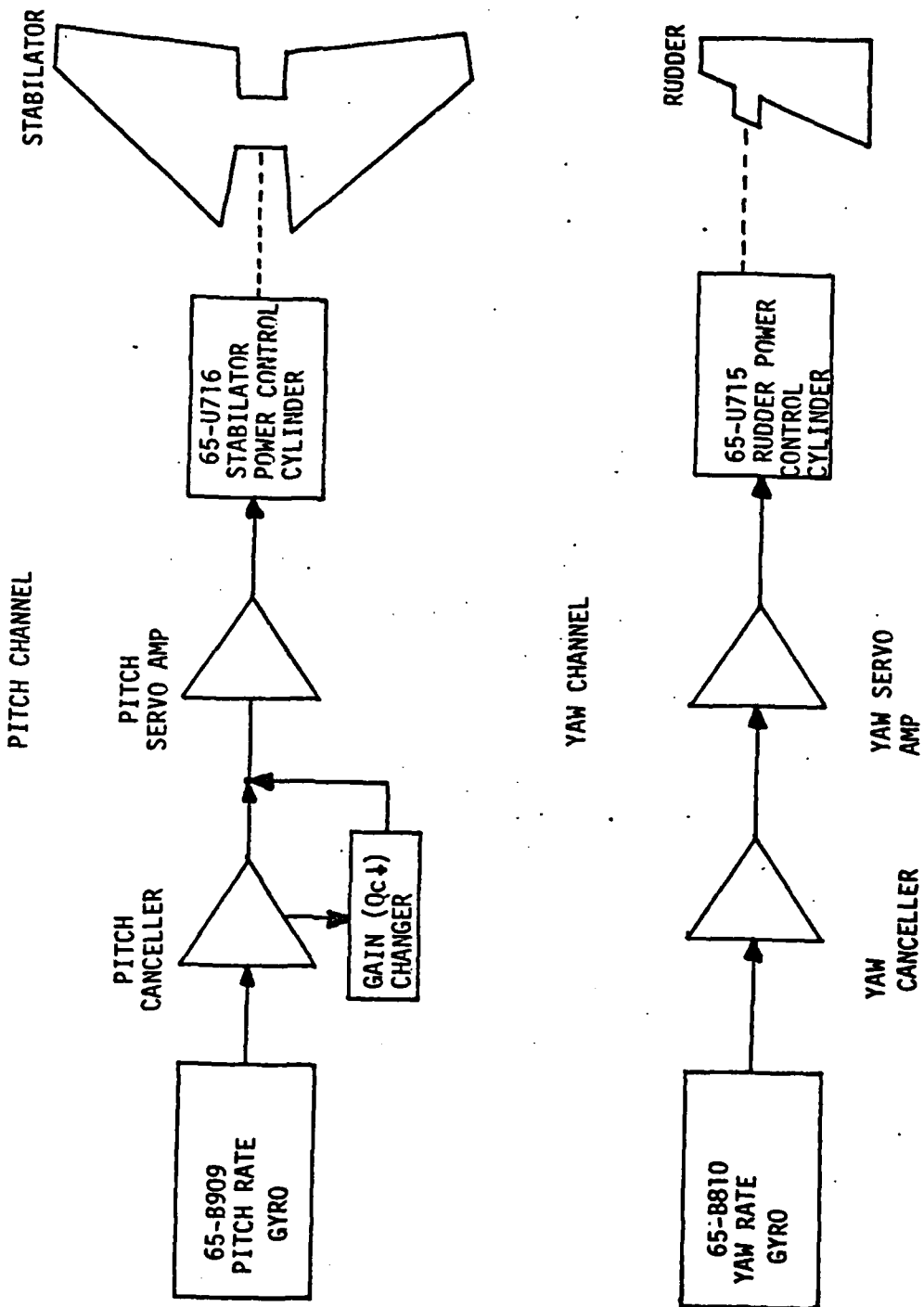

INVESTIGATION REPORT F-4C-12

ENGINEER Gordon B. Buckley  
Gordon B. Buckley

INVESTIGATION REPORT F-4C-13

The sync drive amplifier is used to provide voltage to the control phase winding of the sync drive motor.

If capacitor C6 or C7 fails shorted there will be no driving voltage from the sync drive amplifier to the sync drive motor.

If the individual diode CR2, CR3, CR4, or CR5 or the pair of diodes CR2-CR5 or CR3-CR4 fails opened, the sync drive amplifier output will be a half-wave rectified signal greatly reducing the control winding voltage in the sync drive motor.

If the pair of diodes CR2-CR4, CR3-CR5, CR2-CR3, or CR4-CR5 or if more than two diodes fail there will be no output signal from the sync drive amplifier.

For the effect each component failure has on the aircraft, see Investigation Reports F-4C-14, F-4C-15, and F-4C-16.



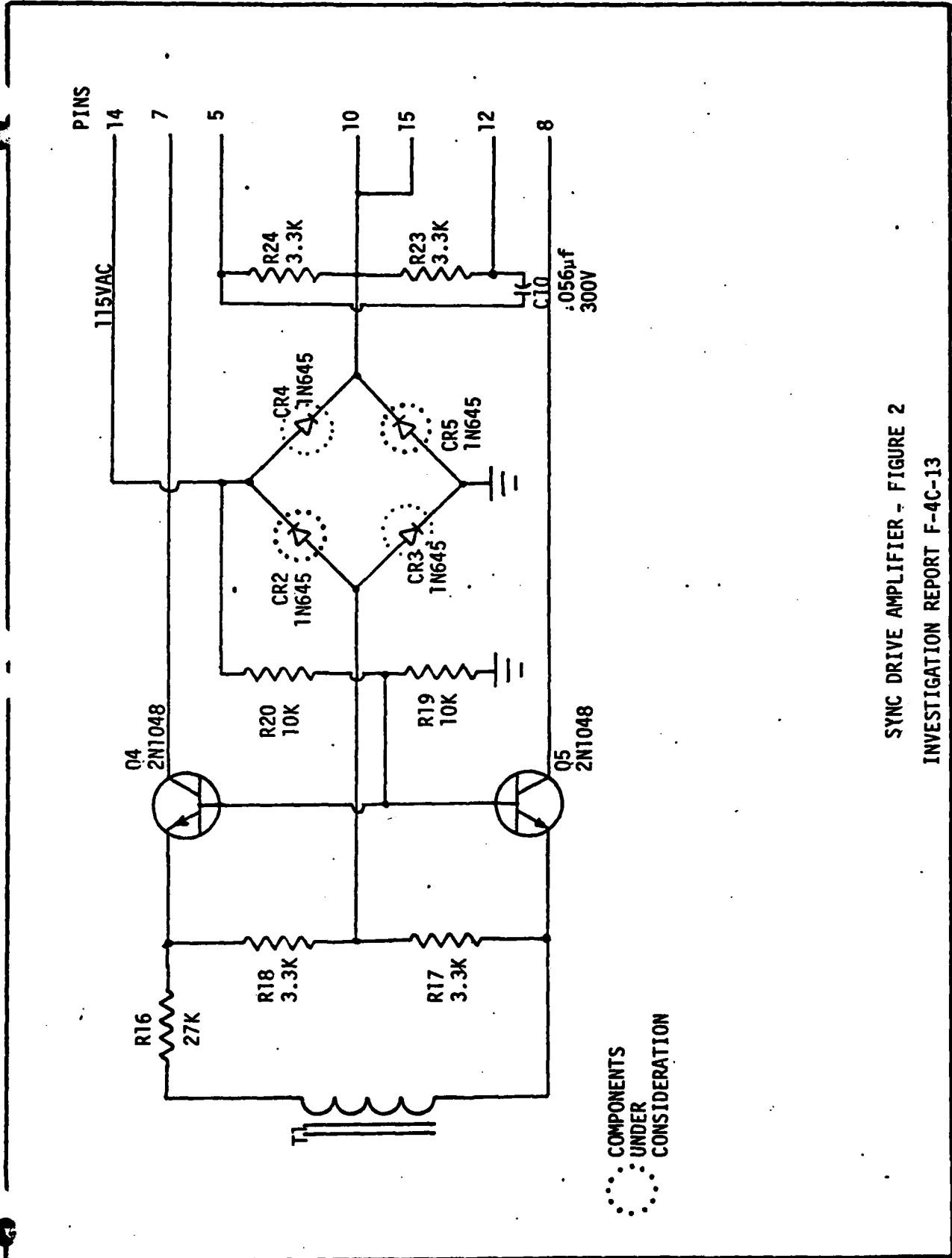

SYNC DRIVE AMPLIFIER - FIGURE 2  
INVESTIGATION REPORT F-4C-13

ENGINEER

*Gordon B. Buckley*  
Gordon B. Buckley

## INVESTIGATION REPORT F-4C-14

When the Course Sync Drive Amplifier is disabled by any of the failures noted in Investigation Report F-4C-13, it cannot drive the Course Sync Drive motor to react to and compensate for the error signals from the Course Sync Drive control transformer and the Roll Rate Gyro (Ref. Des. 65-B307).

The output of the Directional Gyro (Ref. Des. 30-Z306) supplies the input signal to the Course Sync Drive control transformer. Due to the Course Sync Drive motor being unable to null the Course Sync Drive control transformer, the output of the control transformer will be an incorrect representation of the signal from the Directional Gyro.

The signal from the control transformer goes to the Adder Attenuator. The output of the Adder Attenuator goes to the Left Roll Servo Amplifier and to the Right Roll Servo Amplifier. The outputs of the servo amplifiers go to their respective servos, the Left Lateral Series Servo (Ref. Des. 65-U914) and the Right Lateral Series Servo (Ref. Des. 65-U813). The servos control their respective ailerons and spoilers.

The heading for which the Course Sync Drive is set when the Course Sync Drive Amplifier is disabled will be the only heading that the roll channel will hold. The heading cannot be changed. If the AFCS is engaged with the Course Sync Drive Amplifier disabled, the aircraft will attempt to assume the last heading held by the roll channel before amplifier failure.

When the Roll Sync Drive Amplifier is disabled by any of the failures noted in Investigation Report F-4C-13, it cannot drive the Roll Sync Drive motor to react to and compensate for the error signals from the Roll Sync Drive control transformer and the Roll Rate Gyro (Ref. Des. 65-B307).

The output of the Vertical Gyro (Ref. Des. 30-Z307) supplies the input signal to the Roll Sync Drive control transformer. Due to the Roll Sync Drive motor being unable to null the Roll Sync Drive control transformer, the output of the control transformer will be an incorrect representation of the signal from the Vertical Gyro.

The signal from the control transformer goes to the Adder Attenuator. The output of the Adder Attenuator goes to the Left Roll Servo Amplifier and to the Right Roll Servo Amplifier. The output of the servo amplifiers go to their respective servos, the Left Lateral Series Servo (Ref. Des. 65-U914) and the Right Lateral Series Servo (Ref. Des. 65-U813). The servos control their respective ailerons and spoilers.

The attitude for which the Roll Sync Drive is set when the Roll Sync Drive amplifier is disabled, will be the only attitude the channel will hold. The attitude cannot be changed. If the AFCS is engaged with the Roll Sync Drive Amplifier disabled, the aircraft will attempt to assume the last roll attitude held by the roll channel before amplifier failure.

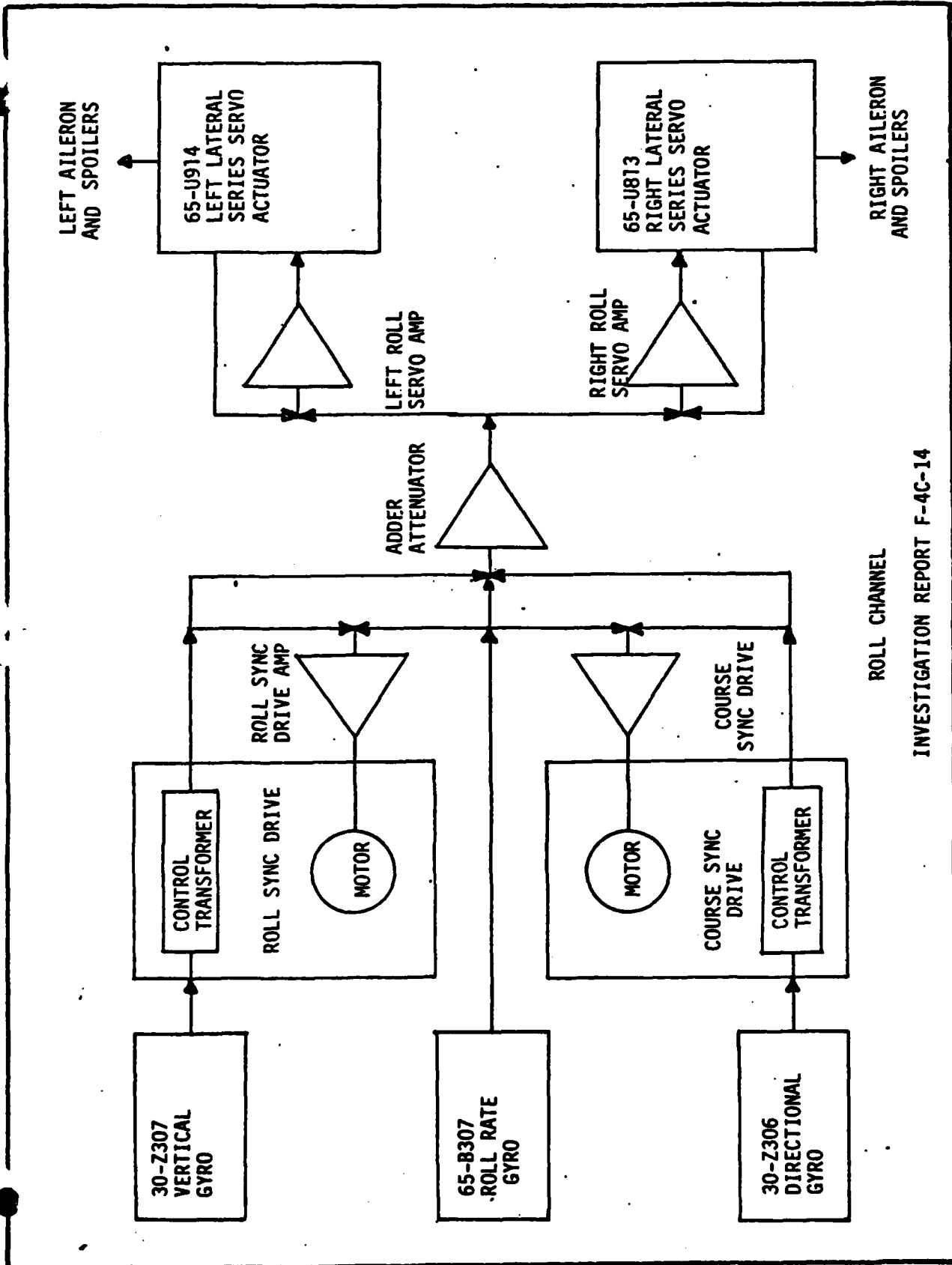

ROLL CHANNEL  
INVESTIGATION REPORT F-4C-14

ENGINEER Gordon B. Buckley  
Gordon B. Buckley

## C INVESTIGATION REPORT F-4C-15

When the Pitch Follow-up Cancellor Sync Drive Amplifier is disabled by any of the failures noted in Investigation Report F-4C-13, it cannot drive the Pitch Follow-up Cancellor Sync Drive motor.

The motor, when not running, cannot drive the control transformer to a position to compensate for the main ram feedback signal. Thus, when the pitch channel error signal is removed from the input of the Pitch Servo Amplifier, the main ram feedback signal will drive the stabilator back to null.

With the Follow-up Cancellor disabled the stabilator will not be able to remain at whatever new position is required to maintain the original attitude with a change in aircraft configuration caused by fuel consumption, stores release, etc. Therefore, the pilot must manually correct for these changes.

If the Sync Drive Amplifier is disabled before AFCS engagement, the uncorrectable error voltage from the Pitch Follow-up Cancellor control transformer or main ram follow-up will be detected by the Electronic Switch-Monitor thus preventing AFCS engagement. For the special case where the stabilator is positioned such that it cancels the error voltage from the control transformer, the AFCS can be engaged but the pitch attitude will not be maintained.

In either case of the Sync Drive Amplifier being disabled, before or after AFCS engagement, the pilot will have to manually adjust pitch to compensate for changes in the aircraft configuration.

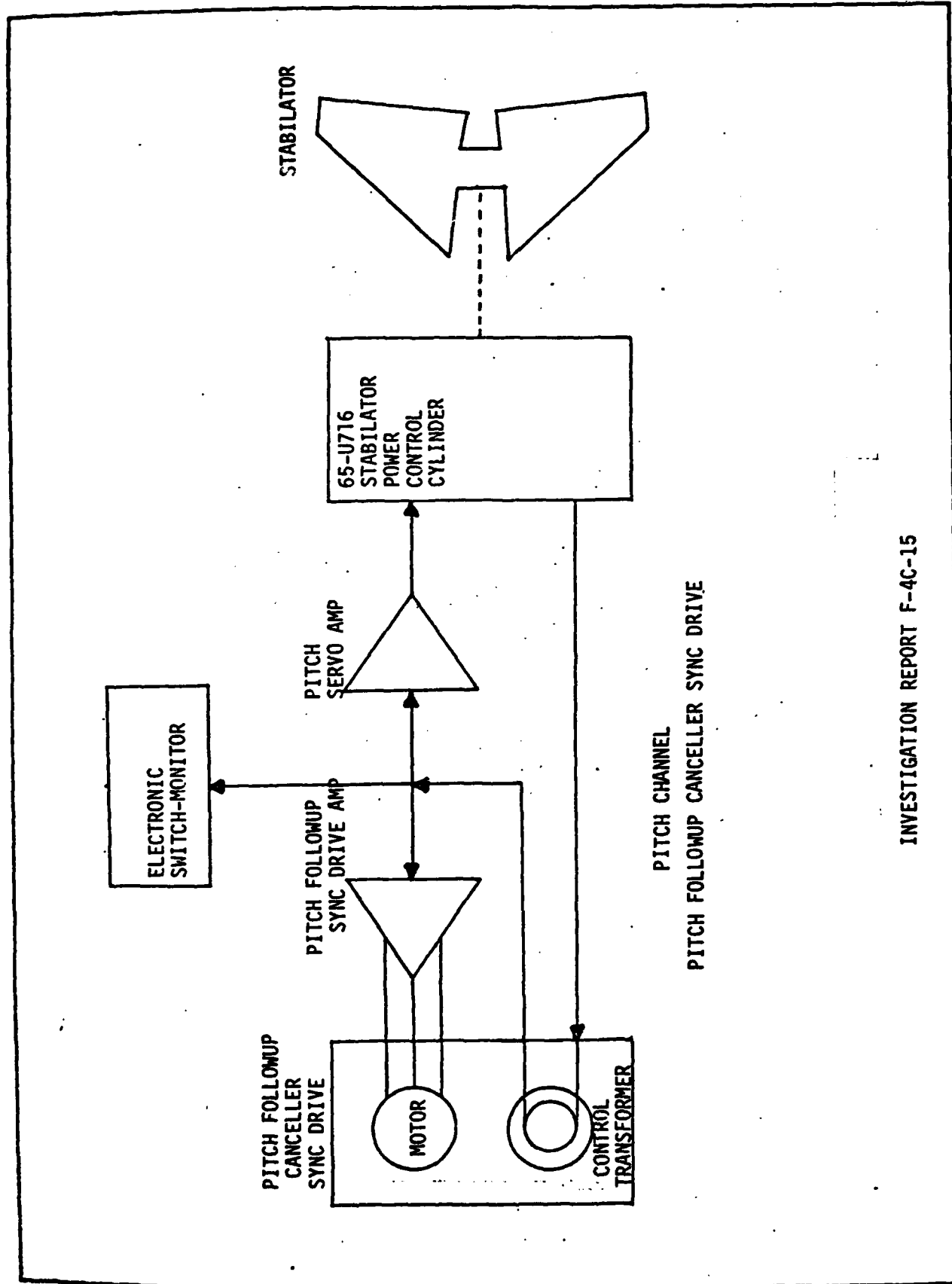

PITCH CHANNEL  
PITCH FOLLOWUP CANCELLER SYNC DRIVE

INVESTIGATION REPORT F-4C-15

ENGINEER

Gordon B. Buckley  
Gordon B. Buckley

## INVESTIGATION REPORT F-4C-16

With the Pitch Sync Drive Amplifier disabled by any of the failures noted in Investigation Report F-4C-13, it will not drive the Pitch Sync Drive motor to react to and compensate for the error signal from the Pitch Sync Drive control transformer.

If the Pitch Sync Drive Amplifier is disabled before AFCS engagement, the uncorrectable error voltage from the Pitch Sync Drive control transformer will be detected by the Electronic Switch-Monitor preventing AFCS engagement. For the special case where the aircraft is at an attitude which will cause the output of the control transformer to be approximately zero, the AFCS can be engaged and that pitch attitude will be maintained.

During AFCS engagement the Stick Force Sensor (Ref. Des. 65-MT223) signal goes to the CADC (Ref. Des. 71-Z311) for gain changing of stick force. The output signal of the CADC is an input into the Pitch Sync Drive Amplifier which is disabled. Therefore, the Stick Force Sensor signal has no affect on stabilator movement.

The output of the Vertical Gyro (Ref. Des. 30-Z307) supplies the input signal to the Pitch Sync Drive control transformer. Due to the Pitch Sync Drive motor being unable to null the Pitch Sync Drive control transformer, the output of the control transformer will be an incorrect representation of the signal from the Vertical Gyro.

The signal from the control transformer goes to the CADC for gain changing of pitch attitude. The output of the CADC goes to the Pitch Servo Amplifier. The Pitch Servo Amplifier controls stabilator movement.

The attitude at which the Pitch Sync Drive is set when the Pitch Sync Drive Amplifier is disabled, will be the only attitude the Pitch Sync Drive will hold and this attitude setting cannot be changed.

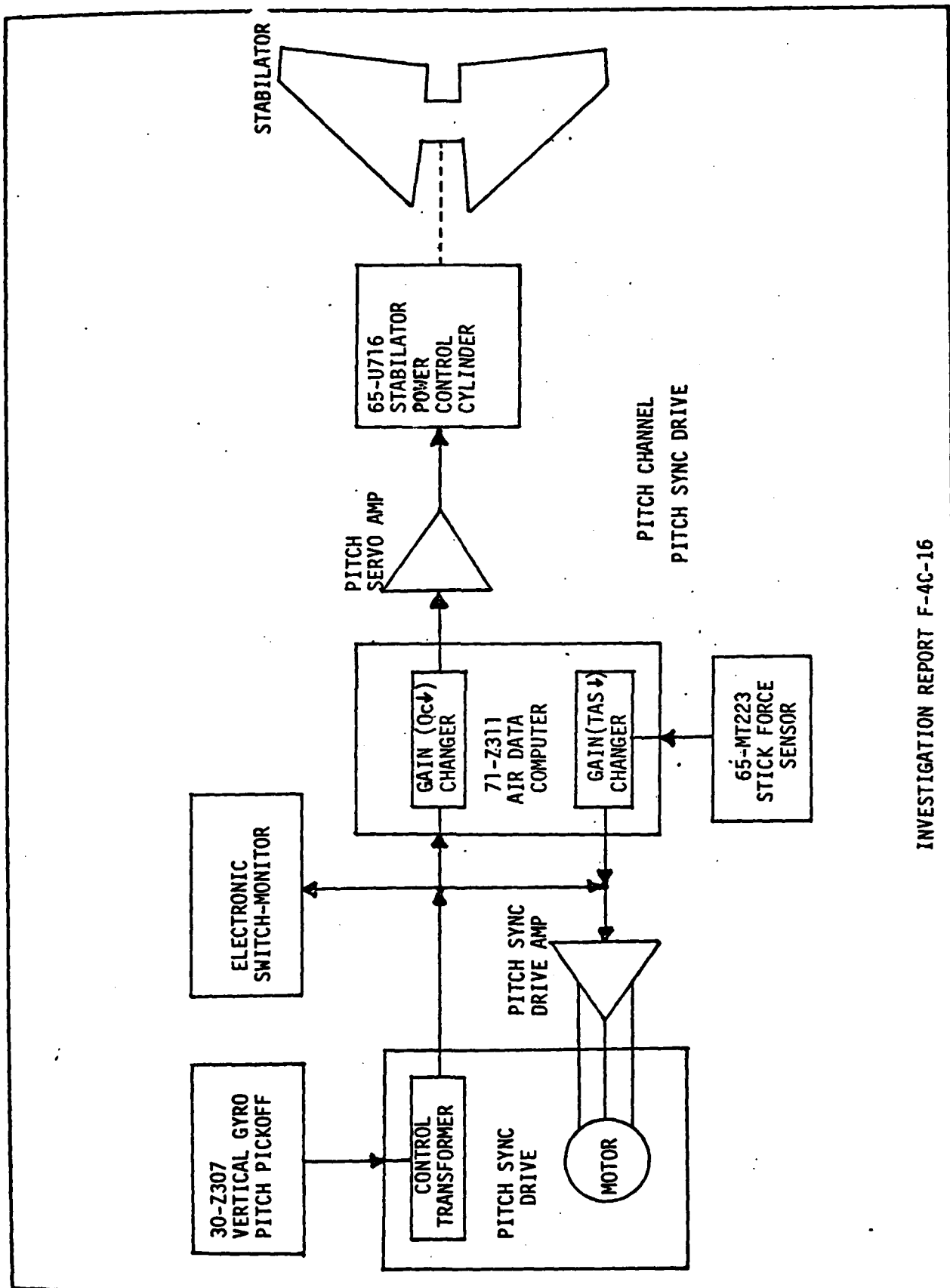

INVESTIGATION REPORT F-4C-16

ENGINEER

*Robert Clardy*  
Robert Clardy

## INVESTIGATION REPORT F-4C-17

Each of the capacitors discussed below is located in a servo amplifier. If any one of them fails shorted, it would short the 115 VAC power supply for its respective amplifier. With the servo amplifier for a given channel disabled, the AFCS can have no effect on that channel's control surface actuator.

Capacitors C2 or C3 in the Pitch Servo Amplifier would short the power source for the amplifier if either of them fails shorted. There would then be no AFCS control over stabilator movement.

Capacitors C2 or C3 in the Left Roll Servo Amplifier would short the power source for the amplifier if either of them fails shorted. There would then be no AFCS control over left aileron and spoilers movement.

Capacitors C2 or C3 in the Right Roll Servo Amplifier would short the power source for the amplifier if either of them fails shorted. There would then be no AFCS control over right aileron and spoilers movement.

Capacitors C2 or C3 in the Yaw Servo Amplifier would short the power source for the amplifier if either of them fails shorted. There would then be no AFCS control over rudder movement.

○ COMPONENTS UNDER CONSIDERATION

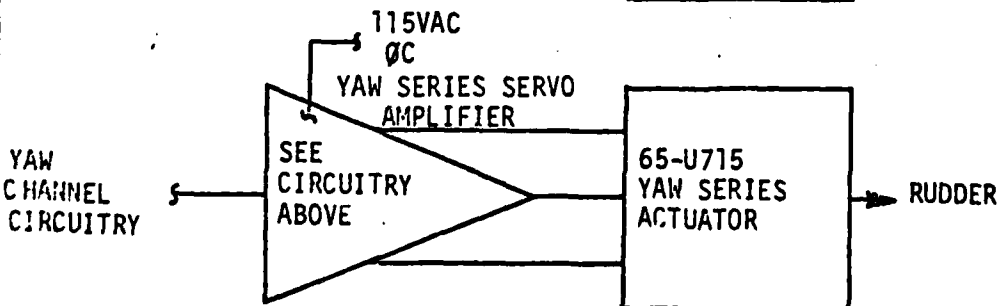
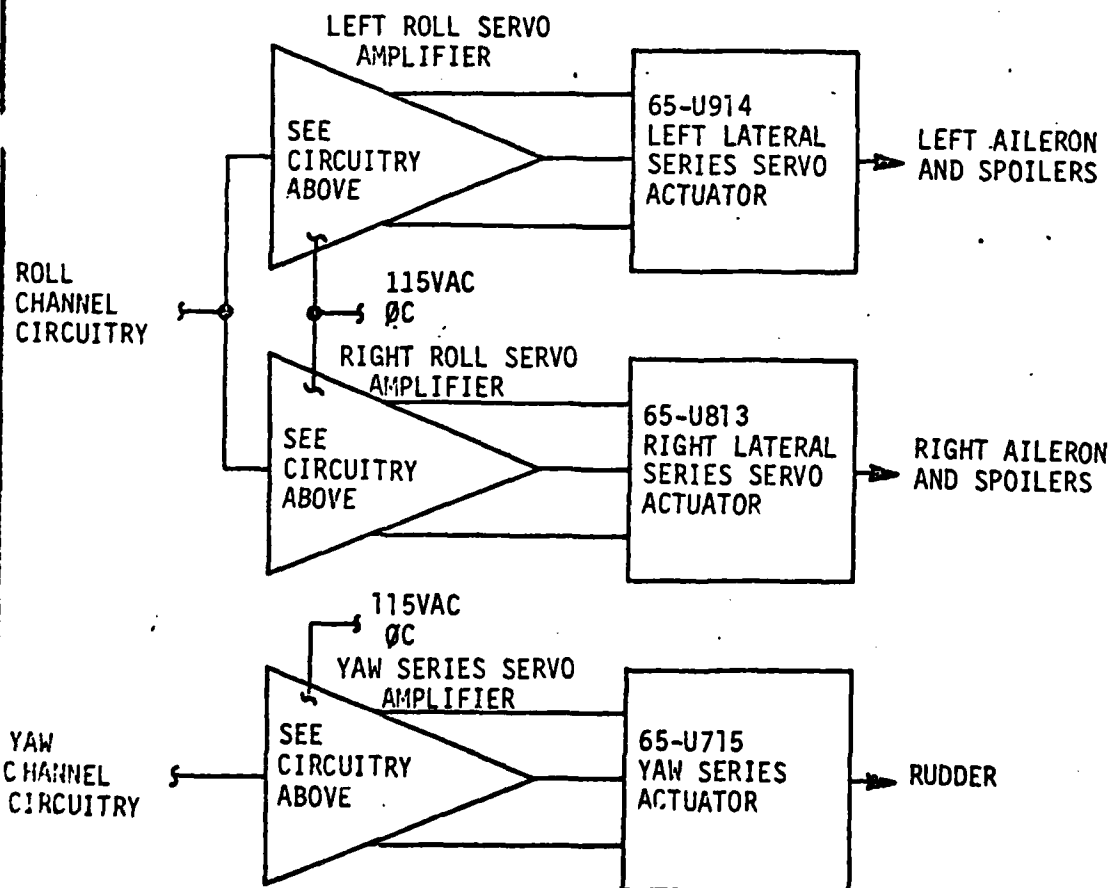
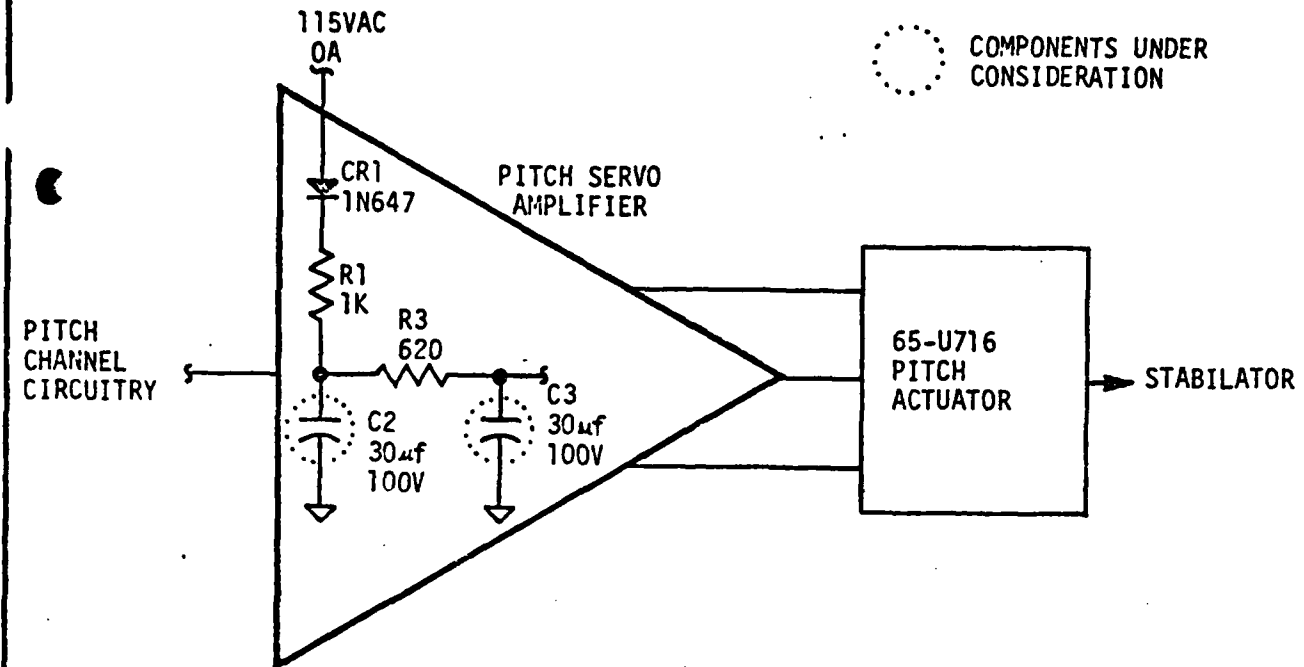

ENGINEER

Don Self  
Don SelfRobert Clardy  
Robert Clardy

## INVESTIGATION REPORT F-4C-18

The capacitors discussed below, all labeled C9, appear between the quadrature rejection stage and the preamplification stage of the autopilot servo amplifiers. If C9 fails shorted, R2 and R19 (see figure) act as a voltage divider between the two stages. This serves to reduce the amplitude of the signal at this point in the amplifier to 2/3 of the expected value. Also, the wave form is distorted since it is not differentiated by the capacitor. The result is that a distorted signal of about 2/3 the proper voltage is applied to the actuator, making it operate more slowly than usual. The net effect is that the affected control surface responds improperly to the rate gyro error signal or the Displacement Gyro error signal. Depending on the flight conditions at the time of failure, the result will be oscillation, slow response, or a need to continuously trim the affected axis.

If capacitor C9 in the Pitch Servo Amplifier fails shorted, it could cause the stabilator to respond improperly to autopilot maneuvers.

If capacitor C9 in the Left Roll Servo Amplifier fails shorted, it could cause the left ailerons and spoilers to respond improperly to autopilot maneuvers.

If capacitor C9 in the Right Roll Servo Amplifier fails shorted, it could cause the right ailerons and spoilers to respond improperly to autopilot maneuvers.

If capacitor C9 in the Yaw Series Servo Amplifier fails shorted, it could cause the rudder to respond improperly to autopilot maneuvers.

SERVO AMPLIFIER

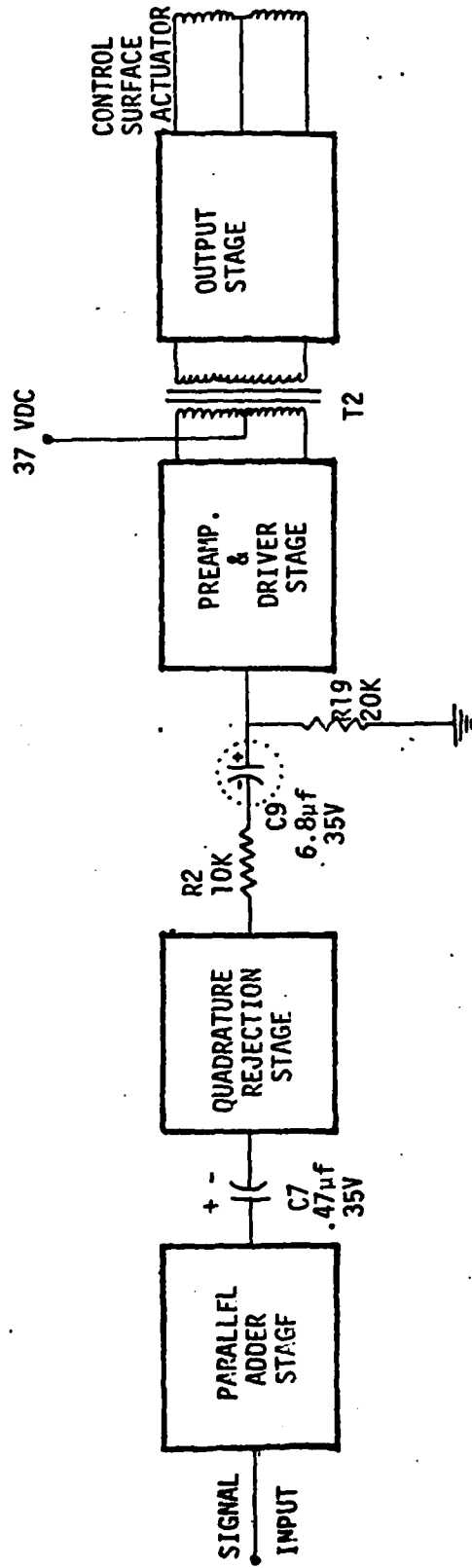

○  
COMPONENT UNDER  
CONSIDERATION

INVESTIGATION REPORT F-4C-18

D2-118545-1

APPENDIX F  
DATA BASELINE

D2-118545-1

The following drawings were used to conduct the F-4C AFCS Sneak Circuit Analysis.

TECHNICAL MANUALS

1F-4C-2-4	Flight Control Systems USAF Series F-4C Aircraft Change 8 - 15 February 1974
1F-4C-2-12	Air Data Computer Set; Altitude Encoder Unit and Associated Pitot Static and Avionic Instruments USAF Series F-4C Aircraft Change 7 - 1 February 1974
1F-4C-2-16	Automatic Flight Control System USAF Series F-4C Aircraft Change 6 - 1 March 1974
1F-4C-2-17	Avionics Navigation Instrument Systems USAF Series F-4C Aircraft Change 7 - 15 April 1974
5A1-2-42-2	Automatic Flight Control Systems AN/ASA-32J and AN/ASA-32M Change 4 - 15 December 1973
5A3-50-3	Depot Overhaul Instructions Change 6 - 15 April 1973
5A3-50-4	Illustrated Parts Breakdown Change 1 - 1 April 1973
5A3-58-2	Aileron Rudder Interconnect Control Amplifier 32-87076-31, 32-87076-301 Change 1 - 15 December 1972

SCHEMATICS (General Electric)

107B7433	Schematic, Electrical - Time Delay Control Rev. A, 5-4-64
113B2751	Schematic, Electrical - Electronic Switch Rev. C, 4-9-68
702C190	Schematic, Electrical - Switch, Monitor Rev. C, 3-31-65
893C321	Schematic, Electrical - Sync Drive, Amplifier Rev. K, 3-31-70

SCHEMATICS (General Electric) (Continued)

925C292	Schematic, Electrical - Adder Attenuator Rev. C, 1-26-66
925C293	Schematic, Electrical - Canceller Amplifier Rev. C, 9-25-69
756 D100	Schematic, Electrical - Servo Amplifier Rev. J, 9-21-70

SCHEMATICS (Air Force - Preliminary)

7327660	(No title available)
X7327681	Controller Assy-Automatic Pilot Engaging Modification of F-4 ACFT
X7327683	Cylinder-Electro Hyd Tandem Power Control Modification of F/RF-4 ACFT
X7329013	Electrical/Electronic Installation - Fwd Fuselage F-4 ACFT, Modification of

LATE  
LME  
-88