

AD-A108 058

TENNESSEE UNIV KNOXVILLE

F/6 11/9

PROCESS FOR THE FORMATION OF BIAXIALLY ORIENTED FILMS OF POLY(P--ETC(U)

NOV 81 J E FLOOD, J L WHITE, J F FELLERS

N00014-77-C-0236

UNCLASSIFIED

PATRA-176

NL

1 1 1
2 2 2

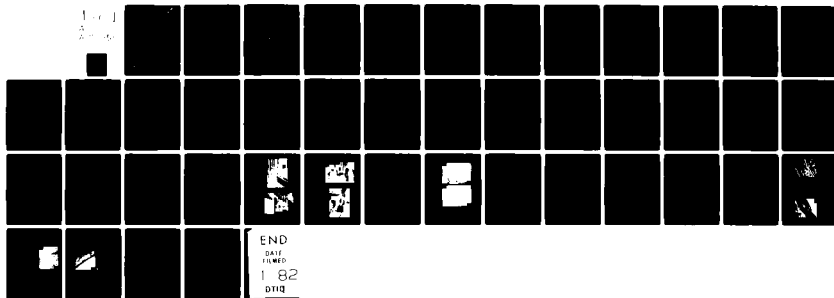

END
DATE
FILMED
1 82
DTIC

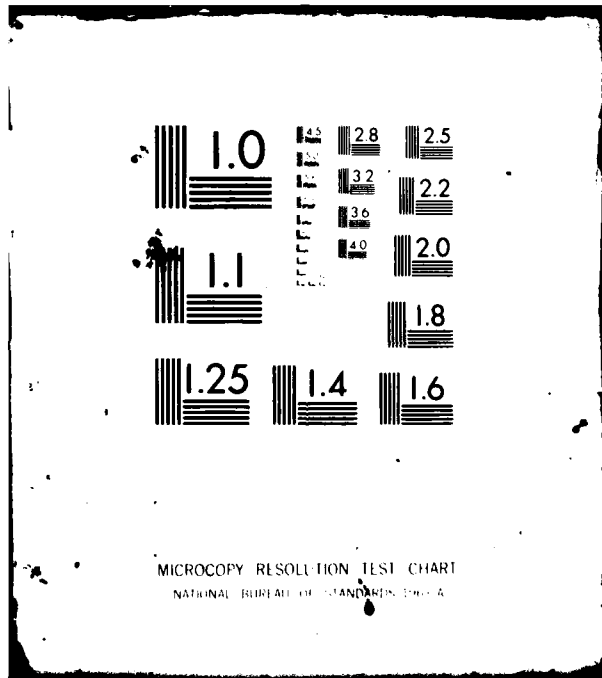

AD A108058



OFFICE OF NAVAL RESEARCH
Contract N00014-77C-0236
Task No. NR 356-639

LEVEL II

TECHNICAL REPORT NO. 6

PROCESS FOR THE FORMATION OF BIAXIALLY ORIENTED FILMS
OF POLY(p-PHENYLENE TEREPHTHALAMIDE) (PPD-T)
FROM LIQUID CRYSTALLINE SOLUTIONS

by

John E. Flood
James L. White
John F. Fellers

Prepared for Publication
in the
Journal of Applied Polymer Science

✓ Polymer Engineering
University of Tennessee
Knoxville, Tennessee 37996-2000 — 346050

Reproduction in whole or in part is permitted for any purpose of the
United States Government.

Approved for Public Release; Distribution Unlimited

DTIC
ELECTE
DEC 2 1981
S D D

DTIC FILE COPY

81 12 02 031

(9) The name of report
 1 Jan 80 - 15 Sep 81

SECURITY CLASSIFICATION OF THIS PAGE (When Data Entered)

REPORT DOCUMENTATION PAGE		READ INSTRUCTIONS BEFORE COMPLETING FORM
1. REPORT NUMBER 6	2. GOVT ACCESSION NO. AD-A108058	3. RECIPIENT'S CATALOG NUMBER 8
4. TITLE (and Subtitle) PROCESS FOR THE FORMATION OF BIAXIALLY ORIENTED FILMS OF POLY(p-PHENYLENE TEREPHTHALAMIDE) (PPD-T) FROM LIQUID CRYSTALLINE SOLUTIONS		5. TYPE OF REPORT & PERIOD COVERED Technical 1-1-80 9-15-81
7. AUTHOR(s) John E. Flood, James L. White, John F. Fellers		6. PERFORMING ORG. REPORT NUMBER PATRA Report No. 176
9. PERFORMING ORGANIZATION NAME AND ADDRESS Polymer Engineering University of Tennessee Knoxville, TN 37996-2000		8. CONTRACT OR GRANT NUMBER(s) 15 N00014-77C-0236
11. CONTROLLING OFFICE NAME AND ADDRESS Office of Naval Research 800 N. Quincy Street Arlington, VA 22217		10. PROGRAM ELEMENT PROJECT, TASK AREA & WORK UNIT NUMBERS -
14. MONITORING AGENCY NAME & ADDRESS (if different from Controlling Office) ORN Resident Representative 325 Hinman Research Bldg. Atlanta, VA 30332		12. REPORT DATE 11-12-81
		13. NUMBER OF PAGES 43
		15. SECURITY CLASS. (of this report)
		15a. DECLASSIFICATION/DOWNGRADING SCHEDULE
16. DISTRIBUTION STATEMENT (of this Report) Approved for Public Release; Distribution Unlimited (14) PATRA-176, TR 6		
17. DISTRIBUTION STATEMENT (of the abstract entered in Block 20, if different from Report) To be published in the J. Appl. Polym. Sci.		
18. SUPPLEMENTARY NOTES		
19. KEY WORDS (Continue on reverse side if necessary and identify by block number) Polymer Liquid Crystal, Kevlar, biaxial orientation, film polymer processing		
20. ABSTRACT (Continue on reverse side if necessary and identify by block number) A new process for making equal biaxially oriented films from liquid crystalline solutions of poly (p-phenylene terephthalamide) (PPD-T) is described. The process involves extruding solutions of PPD-T/H ₂ SO ₄ through an annular die and over an oil coated mandrel into a coagulation bath. The films were studied using wide angle X-ray diffraction (WAXS) and scanning electron microscopy (SEM). Tensile stress-strain properties were obtained on samples cut at various directions in the plane of the film. Biaxially oriented		

DD FORM 1 JAN 73 1473

EDITION OF 1 NOV 65 IS OBSOLETE
 S/N 0102-LF-014-6601

3416650
 SECURITY CLASSIFICATION OF THIS PAGE (When Data Entered)

films were produced which possess equal properties in the various directions in the plane of the film. Moduli of 2.3×10^9 pascal and tensile strengths of 9.6×10^7 pascal were obtained in the plane of the film. Films with unequal biaxial orientation were also produced. These tend to have higher modulus/tensile strength in the direction of major orientation, the machine direction, (up to 8.3×10^9 pascal/ 2.5×10^8 pascal) but become brittle in the transverse direction.

Accession For	
NTIS GRA&I	<input checked="" type="checkbox"/>
DTIC TAB	<input type="checkbox"/>
Unannounced	<input type="checkbox"/>
Justification	
By _____	
Distribution/ _____	
Availability Codes	
Dist	Avail and/or Special
A	

DTIC
ELECTED
S DEC 2 1981 D
D

INTRODUCTION

One of the most striking developments in polymer technology during the past decade has been duPont's development of high modulus and tensile strength aromatic polyamide fibers through the spinning of liquid crystalline polymer solutions (1 - 4). This technology, largely reproduced some years ago in our own (5) and other industrial laboratories (6) has inspired various research teams to both search for new liquid crystalline polymer systems (7 - 18) and investigate their structure in the quiescent state (14, 17, 19, 20) and in flow (16, 21-25). This has in turn led to continuing efforts in various industrial concerns (7-11, 15) and our own laboratories (16, 26) to develop new fiber spinning processes based on a range of liquid crystalline polymer fluids.

As indicated in the above paragraph, the industrial processing efforts have been almost entirely involved in the development of high modulus fibers. Only two research teams have described efforts to develop more complex processing procedures and products. Tennessee Eastman investigators (8, 9) have described the injection molding of liquid crystalline polyesters. The second process is one developed in our own laboratories which involves the continuous formation of film from solutions of poly (p-phenylene terephthalamide) (PPD-T) or redissolved Kevlar[®] fiber in sulfuric acid. Aoki, Onogi, White and Fellers (27) have described a process in which solution emerging from an annular die is extruded and internally pressured with a gas, analogous to tubular film extrusion. The blown PPD-T/H₂SO₄ fluid annulus then entered a water bath which extracted the H₂SO₄ and coagulated the PPD-T. It was not, however, possible to develop a high level of biaxial orientation in this manner and the process did not operate in a stable manner.

It is our purpose in the present paper to describe an improved process for producing PPD-T films. The new process involves the use of extrusion from an annular die over an external mandrel rather than a tubular blowing procedure. Mandrel processes have a long history in polymer processing. More than a century ago John Wesley Hyatt (28) developed and applied such a technique to produce hollow shapes from Celluloid. There have been in latter years various patents using mandrel processes for producing tubing, sheeting and film (29-34) though none has dealt with liquid crystalline polymers or PPD-T.

MATERIALS

The starting polymer was duPont Kevlar[®] 29 which has been identified by various investigators as being poly (p-phenylene terephthalamide) (PPD-T)

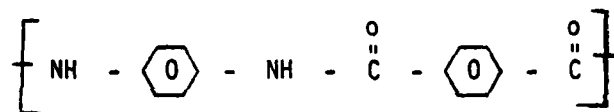

This was dissolved in 100% sulfuric acid prepared by mixing together fuming sulfuric acid (with 30% excess SO₃ obtained from Fisher Chemical) with 96% concentrated sulfuric acid (also from Fisher Chemical).

The dissolution of Kevlar[®] 29 in sulfuric acid was carried out in a dry box filled with nitrogen to avoid absorption of moisture. Mixing was first carried out by hand at about 60-70°C. This is followed by periods of "shaking" in a mechanical blender. The mixing step involves combining typically 350-375 ml of H₂SO₄ with 120-130 grams of Kevlar in an 800 ml jar. Bubbles are removed from the polymer solutions by means of a vacuum pump (35).

MANDREL FILM PROCESS

Description

The film was produced by extrusion through an annular die using the apparatus of Figures 1-3. Oil is fed through a 1/4-horsepower Zenith gear pump into a cylindrical reservoir containing a piston below which is the solution of PPD-T/H₂SO₄. The oil pressure forces the piston downward, pushing the solution into an annular die of inside radius 49.45 mm and annular gap of 0.3 mm. The reservoir and annular die system are made from Type 304 stainless steel to prevent corrosion by the H₂SO₄. The piston is made from stainless steel surrounded by a Teflon[®] seal.

The solution emerges from the die and flows or is drawn over a conical mandrel made from polyvinyl chloride. The mandrel is coated with an oil pumped from an overhead separatory funnel through the die. The purpose of the oil is to reduce friction and induce biaxial elongational flow in the PPD-T/H₂SO₄ solution. The mandrel used is 107 mm high, with a diameter of 33 mm at its top and 165 mm at its bottom.

The film moves from the mandrel into the coagulation bath at room temperature which contains liquids such as water, methanol (MeOH), ethanol (EtOH) or their mixtures. These liquids extract the H₂SO₄ from the solution and coagulate the PPD-T into a film. The film is taken up at the other end of the bath. More detailed information on apparatus design is given by Flood (33) elsewhere.

Process Analysis

Let us take the flow direction to be '1', the transverse direction around the circumference of mandrel to be '2' and the thickness direction '3'.

Our process involves the two phase flow of a PPD-T solution and an oil over a conical mandrel. We need first concern ourselves with the velocity profiles in the two phases. Taking the thickness H of the solution plus the oil layers to be much less than the radius of curvature of the mandrel, we may presume the flow to be equivalent to approximately gravity flow down an inclined plane. This is described by a force balance relating gravity forces and shear stress σ_{13} according to (36)

$$\frac{d\sigma_{13}}{dx_3} = -\rho_j g \cos \theta \quad (2)$$

where θ is the half cone angle and ρ_j is the density of the j phase. If we presume each of the phases is a Newtonian fluid and neglect the differences in their densities, the velocities of the oil and solution phases are simply:

$$(v_1)_{oil}(x_3) = \frac{\rho g \cos \theta}{2\eta_{oil}} [2Hx_3 - x_3^2]$$

$$(v_1)_{sol}(x_3) = \frac{\rho g \cos \theta}{2\eta_{sol}} \left[\left(1 - \frac{\eta_{oil}}{\eta_{sol}}\right) (2H\Delta - \Delta^2) + \frac{\eta_{oil}}{\eta_{sol}} (2Hx_3 - x_3^2) \right] \quad (2a, b)$$

If the viscosity of the solution is much greater than the oil, the velocity profile in the solution goes to

$$(v_1)_{sol} = \frac{\rho g \cos \theta}{2\eta_{sol}} [2H\Delta - \Delta^2] \quad (3)$$

The velocity field becomes plug flow. This means that the flow field is purely elongational.

The conclusions of the above paragraph should remain valid if the fluid is non-Newtonian with a viscosity decreasing as a function of shear rate. Indeed the tendency to a flat velocity profile is even accentuated by this effect.

We presume elongation flow in the PPD-T/H₂SO₄ film moving down the mandrel. Letting h be the thickness of the solution film, R the local cone radius, the velocity gradients in the film are (37, 38)

$$\frac{\partial v_3}{\partial \xi_3} = \frac{Q \cos \theta}{2\pi R h} \left(\frac{1}{h} \frac{dh}{dz} \right) \quad (3a)$$

$$\frac{\partial v_2}{\partial \xi_2} = \frac{Q \cos \theta}{2\pi R h} \left(\frac{1}{R} \frac{dR}{dz} \right) \quad (3b)$$

$$\frac{\partial v_1}{\partial \xi_1} = \frac{Q \cos \theta}{2\pi R h} \left(-\frac{1}{h} \frac{dh}{dz} - \frac{1}{R} \frac{dR}{dz} \right) \quad (3c)$$

Here Q is the extrusion rate and z the altitude of the cone. The expanding radius $R(z)$ of the cone ensures a velocity gradient in the transverse direction.

Various special cases may be noted. If we consider take-up of the annular film in the absence of the mandrel, uniaxial extension results

$$\frac{\partial v_2}{\partial \xi_2} = \frac{\partial v_3}{\partial \xi_3} \quad (4a)$$

thus

$$\frac{1}{R} \frac{dR}{dz} = \frac{1}{h} \frac{dh}{dz} \quad (4b)$$

which leads to the emerging annulus being drawn down through the air gap according to

$$\frac{R(z)}{R_0} = \frac{h(z)}{h} = \sqrt{\frac{v_1(0)}{v_1(z)}} \quad (4c)$$

If the mandrel is present $R(z)$ must be an increasing function defined by the mandrel shape. We desire an equal biaxial extension. For this case

$$\frac{\partial v_1}{\partial \xi_1} = \frac{\partial v_2}{\partial \xi_2} \quad (5a)$$

thus

$$-\frac{1}{R} \frac{dR}{dz} - \frac{1}{h} \frac{dh}{dz} = \frac{1}{R} \frac{dR}{dz} \quad (5b)$$

which leads to

$$\frac{R(z)}{R_0} = \left(\frac{h_0}{h(z)} \right)^{\frac{1}{2}} = \frac{v_1(z)}{v_1(0)} \quad (5c)$$

Such a case is possible in the presence of a mandrel. However, to achieve this the fluid must also respond in a manner compatible with the balance of forces.

Equilibrium of forces in flow down a mandrel derive from the theory of membranes (39). These have the form:

$$\frac{d}{d\theta} R h \sigma_{11} - r_a h \sigma_{22} \cos\theta + p_\theta R r_a = 0 \quad (6a, b)$$

$$\frac{h \sigma_{11}}{r_a} + \frac{h \sigma_{22}}{r_b} = p_r$$

Here r_a and r_b are radii of curvature in the machine and transverse directions (see Figure 1). p_r and p_θ are related to the pressures within the oil and gravity through

$$p_r = p - \rho gh \cos \theta$$

$$p_\theta = \rho gh \sin \theta$$

(7a, b)

where p is ambient (atmospheric) pressure

The stress σ_{11} may be shown to be of form:

$$\sigma_{11} = \frac{1}{r \sin \theta} \left[\int_{r_a}^{r_b} (p_r \cos \theta - p_\theta \sin \theta) \sin \theta d\theta + C \right] \quad (8)$$

where C is a constant of integration.

To proceed further we need a constitutive equation describing the flow characteristics of the solution. Such formulations do not exist for liquid crystalline polymer systems. However, this type of problem has been investigated for both Newtonian fluid (40) and elastic solid (41, 42) models.

Process Conditions

It is possible to operate the apparatus over a wide range of conditions of concentrations and temperatures, especially without the mandrel. The conditions where the mandrel is required are more limited but still broad. It was however, our intention to operate under conditions wherein the PPD-T/H₂SO₄ solutions are in a liquid crystalline form. This is defined by the approximate phase diagram of Figure 4 which shows the concentration and temperature conditions under which this system exists in different forms. This figure was constructed from both observations using a Leitz-Wetzlar polarized light microscope and reference to the literature (1, 43). We primarily limited our efforts to liquid crystalline regions. Polarized light photomicrographs of some of the liquid crystalline solutions are shown in Figure 5.

The various process conditions investigated are summarized in Table 1. It was found that higher solution concentrations made the polymer solution easier to work with in terms of processability. This necessitates moving

to higher temperatures. The optimum conditions were found to be 70°C and a concentration of 17 weight percent. At higher temperatures, we started to have problems of chemical stability. Concentrations higher than 17% were considerably more difficult to mix into a homogeneous solution.

Various other processing problems are noted here. The viscosity of the oil coating the mandrel proved important. To have stable film flow over the mandrel, a hydrocarbon oil had to be in the viscosity range 170 to 370 centipoise. While the densities of the two phases were generally close, it is also necessary to choose the oil coating the mandrel to be denser than the coagulant. This is to insure it will sink to the bottom of the tank and not seek to float on the surface. If it does this it will disrupt the film being formed.

A range of coagulants were used as may be seen in Table 1. Most proved satisfactory from the process point of view. As one proceeds from pure water to pure alcohol, the density decreases. The hydrocarbon oils used with alcohols could not be used with water. In practice we generally used coagulants with 25 weight percent or less water.

FILM CHARACTERIZATION

WAXS Measurements

The structure of the films produced were examined using wide angle X-ray diffraction (WAXS). Pole figures (44) were prepared using a single crystal orienter mounted on a General Electric XRD-5 diffractometer. The radiation used was CuK α with a wavelength of 0.154 nm. The films prepared were stacked and glued together at their edges and mounted on the single crystal orienter. This is the same apparatus used in the studies of Choi, Spruiell and White (45) on polyethylene tubular film.

The biaxial orientation factors of White and Spruiell (38, 45, 46)

$$f_{1j}^B = 2 \overline{\cos^2 \phi_{1j}} + \overline{\cos^2 \phi_{2j}} - 1 \quad (7a, b)$$

$$f_{2j}^B = 2 \overline{\cos^2 \phi_{2j}} + \overline{\cos^2 \phi_{1j}} - 1$$

were computed from the pole figures. Here ϕ_{1j} and ϕ_{2j} are the angles between the machine (1) and transverse directions (2) and the j crystallographic axis.

Northolt (47) has reported that an orthorhombic unit cell with unit cell dimensions of $a = 0.787$ nm, $b = 0.518$ nm, $c = 1.29$ nm (chain axis). The primary reflections used were the (110), (200) and (006) (see Table 2). The (200) reflection may be used to directly compute $\overline{\cos^2 \phi_{1a}}$ and $\overline{\cos^2 \phi_{2a}}$. The (200) and (110) reflections were used in the manner of Stein (48) to calculate the $\overline{\cos^2 \phi_{1b}}$ and $\overline{\cos^2 \phi_{2b}}$. The $\overline{\cos^2 \phi_{1c}}$ and $\overline{\cos^2 \phi_{2c}}$ were determined from the Pythagorean Theorem.

Scanning Electric Microscopy

The films were characterized using an AMR high resolution Scanning Electron Microscope. The films were coated with a gold-palladium alloy. They were examined along a fracture edge and also normal to the film surface.

Shrinkage

A five cm square sample was cut from the film while still in the coagulation bath. The film was then placed in the open air for a period of 24 hours. Measurements were made to determine the amount of film shrinkage in the machine and the transverse direction.

Mechanical Properties

Tensile measurements were made on films using a Table Model Instron Tensile Testing Machine. Measurements were made in the machine and transverse directions and at a 45° angle. A gauge length of 20 mm was used in most experiments and the crosshead speed was 2 mm/minute.

RESULTS OF FILM CHARACTERIZATION

Thickness

The films produced without drawdown are the thickest, being of order 0.25 - 1 mm. The films drawn down uniaxially without a mandrel have thickness of order 0.026 to 0.2 mm. The films drawn over the mandrel are of order 0.005 to 0.1 mm.

WAXS

WAXS measurements on the films coagulated in alcohol solutions show the reflections described by Northolt (47) (see Table 2). However, films coagulated in water baths exhibit some different reflections. These are at 0.51 nm, 0.53 nm, and 0.215 nm respectively.

Typical (006) and (200) pole figures for a film extruded through an annular die into a coagulation bath without take-up are shown in Figure 6. The influence of drawdown on orientation is shown in Figure 7. Introduction of the mandrel makes the orientation of the films vary as shown in Figure 8. The effect of enhanced drawdown over the mandrel is shown in Figure 9.

Figure 6 indicates the existence of uniaxial orientation in the machine direction. The c -axis shows some orientation in the machine direction, while the a axis orientation exhibits a symmetric orientation about this axis. Figure 7 shows an enhanced uniaxial orientation.

The film pulled down over the mandrel shows a biaxial orientation with the c -axis being approximately equally distributed between the machine direction and the transverse direction. This is shown in Figure 8. Polymer chain orientation in the machine direction is increased as the drawdown is increased (Figure 9).

Biaxial orientation factors were determined from the pole figures. These results are summarized in Table 3. Figure 10 uses the orientation triangle of White and Spruiell (46) to represent the c -axis orientation factors.

The films extruded directly into the bath may be seen to place near the f_{1c}^B axis indicating some uniaxial orientation. They have f_{1c}^B of 0.3 and f_{2c}^B of 0.1. Films drawn down without a mandrel appear at a higher position on the f_{1c}^B axis indicating much higher uniaxial orientation. They have f_{1c}^B about 0.47 and f_{1c}^B of 0.13. Stretching the film over a mandrel creates nearly equal biaxial orientation factors placing the data approximately on an altitude of the orientation triangle. Values of f_{1c}^B about 0.25 and f_{2c}^B of 0.28 are obtained. With increasing drawdown ratios, the orientation factors place at an intermediate position between the f_{1c}^B axis and the altitude.

SEM Photomicrographs

SEM Photomicrographs of film cross-sections are shown in Figures 11 to 13. The thick films with little drawdown exhibit complex void structures near the center of the film cross-section. The voids are elongated and perpendicular to the machine direction. For the uniaxially drawdown films and those stretched over the mandrel, the voids show a much lower stage of development. Those voids were not visible in SEM; the surface appeared to be solid. Biaxial films exhibited a solid cross section similar to the uniaxially drawn films.

Shrinkage

The percent shrinkages of the film after removal from the coagulant are summarized in Table 4. The shrinkage is primarily a function of the state of orientation and only secondarily related to coagulant. Other factors may also be involved.

Mechanical Properties

Typical modulus and breaking stress data may be seen in Table 5. The Young's modulus of the films are of order $2 \times 10^8 - 8.3 \times 10^9$ pascal. Polar diagrams of the tensile strength of the PPD-T films are shown in Figures 14 and 15.

It can be seen that the uniaxial films are highly anisotropic with tensile strength of order 1.2×10^8 pascals in the machine direction and 7.5×10^6 pascal in the transverse direction. Uniaxially drawn films coagulated in water had tensile strengths in the machine direction as high as 2.8×10^8 pascals. Films drawn over the mandrel have more balanced mechanical behavior. Tensile strengths in the machine and transverse directions of 5.2×10^7 pascals are observed.

The elongations to break of the films are of order 3 - 16% for the simple extruded films in the machine direction and 3 - 12% in the transverse direction. For the uniaxial films, they are 3 - 12% in the machine direction and much smaller in the transverse direction. For the biaxial films, we obtain 7 - 11% in the machine and 4 - 8% in the transverse. Percent elongation was difficult to quantify in terms of film direction due to film wrinkling, especially for the undrawn films, and the uniaxially drawn film. Wrinkles were usually in the machine direction. Other problems with edge effects and voids probably contributed to premature failure in all of the films.

DISCUSSION

Crystallography

The films formed in the water coagulating baths exhibited different reflections from those formed in alcohol coagulants. Similar observations have been made on wet spun fibers by Hancock et al (5) in our laboratories. Haraguchi, Kagiya and Takayanagi (49) have confirmed this and proposed that there is a second crystalline modification with a different unit cell. This has an orthorhombic form with dimensions $a=0.80$ nm, $b=0.51$ nm, and $c=1.29$ nm (chain axis). Only the 'a' and 'b' crystallographic axis repeat distances change dimensions, as would be expected.

Orientation

There are some striking observations on the orientation development in the film process. First it is found that films extruded directly into the bath exhibited significant uniaxial orientation even though no tensions were applied. This orientation may be represented by the biaxial orientation factor.

The retention of flow orientation after exiting from the die is suggested by the observations of Onogi et al (25) of a very slow birefringence decay in hydroxypropylcellulose solutions. Striking retention of die orientation in extruded filaments of liquid crystalline hydroxypropylcellulose melts was also reported by Shimamura et al (16).

The second remarkable observation is the successful formation of an equally biaxial oriented film with biaxial orientation factors as high as 0.35 and 0.45. Values of f_C^B and f_C^B of 0.5 represent an equal and complete biaxial planar orientation. While it has been established at least since the work of Blades (2) that it is possible to develop high levels of uniaxial orientations from liquid crystalline polymers, it has not been previously realized that one may obtain such levels of equal biaxial orientation.

Mechanical Properties

The variation in mechanical properties with film orientation indicated striking effects. While high machine direction modulus (8×10^9 pascals) may be developed in uniaxial films, they are brittle and fibrillate readily in the transverse direction. However, once equal biaxial orientation is achieved, good properties may be obtained in all directions in the plane of the film. It should also be noted that none of these films have been annealed under tension as is the case of Kevlar[®] fibers. Annealing Kevlar[®] fibers under tension at temperatures of 300° to 500° C is known to create a marked increase in

modulus and tensile strength (2). Typical modulus, tensile strength, and per cent elongation values for Kevlar[®] fibers are respectively 8.3×10^{10} pascal, 3.6×10^9 pascal and 4.4. Biaxially oriented polyethylene terephthalate films have been reported (50) with property values of modulus, tensile strength and per cent elongation being respectively 4×10^9 pascals, 2.5×10^8 pascals and 1. to 4%.

FUTURE WORK

Much needs to be done to optimize the process described in this paper. We have not as yet carefully investigated the annealing of the films which will probably upgrade their properties. Annealing plays a key role in the formation of high modulus aromatic fibers (1, 2, 4). Also we have only looked at a single mandrel shape. By varying the cone-angle or even going to other mandrel shapes we may be able to produce films of quite different characteristics. We wish to scale up our process to higher production rates and enable not only longer runs but the formation of larger annular films.

ACKNOWLEDGEMENT

This research was supported by the Office of Naval Research.

REFERENCES

1. S. L. Kwolek,
U.S. Patent 3,671,542 (1972)
2. H. Blades,
U.S. Patent 3,767,756 (1973)
3. P. W. Morgan,
Macromolecules, 10, 1381 (1977)
4. S. L. Kwolek, P. W. Morgan, J. R. Schaeffgen and L. W. Guirich,
Macromolecules, 10, 1390 (1977)
5. T. A. Hancock, J. E. Spruiell and J. L. White,
J Appl Polym Sci, 21, 1227 (1977)
6. I. Hay,
Seminar, University of Tennessee, ca 1975
7. W. J. Jackson and H. F. Kuhfuss,
J Polym Sci Polym Phys 14, 2043 (1976)
U.S. Patent 3,778,410 (1973)
U.S. Patent 3,804,805 (1974)
8. W. J. Jackson,
British Polymer Journal, p. 154 (1980)
9. W. J. Jackson and H. F. Kuhfuss,
J Appl Polym Sci 25, 1685 (1980)
10. J. J. Kleinschuster,
U.S. Patent 3,991,014 (1976)
11. G. W. Callandam,
U.S. Patent 4,067,852 (1978)
12. B. P. Griffin and M. K. Cox,
British Polymer Journal, p. 147 (1976)
13. J. I. Jin, S. Antour, C. Ober and R. W. Lenz,
British Polymer Journal, p. 132 (1980)
14. R. S. Werbowj and D. G. Gray,
Mol Liq Cryst 34, (letters), 97 (1976)
Macromolecules 13, 69 (1980)
15. M. Panar and O. B. Willcox,
West German Offenlegungsschrift 27 65 0382 (1977)
16. K. Shimamura, J. L. White and J. F. Fellers,
J Appl Polym Sci 26, 2165 (1981)

17. S. M. Aharoni,
Macromolecules 12, 94 (1979)
18. C. P. Wong, H. Ohnuma and G. C. Berry,
J Polym Sci Polym Symp 65, 173 (1978)
19. Y. Onogi, J. L. White and J. F. Fellers
J Polym Sci Polym Phys 18, 663 (1980)
20. J. Bheda, J. F. Fellers and J. L. White,
Colloid Polym Sci 250, 1335 (1980)
21. S. P. Papkov, V. G. Kulichikhin, V. D. Kalmykova and A. Y. Malkin
J Polym Sci Polym Phys 12, 753 (1974)
22. E. Iizuka,
Mol Cryst Liq Cryst 25, 287 (1974)
23. H. Aoki, J. L. White and J. F. Fellers,
J Appl Polym Sci 23, 2293 (1979)
24. D. G. Baird,
J Appl Polym Sci 22, 2701 (1978)
J Rheol 24, 465 (1980)
25. Y. Onogi, J. L. White and J. F. Fellers,
J Non Newt Fluid Mech 7, 121 (1980)
26. J. Bheda, J. F. Fellers and J. L. White
J Appl Polym Sci (in press)
27. H. Aoki, Y. Onogi, J. L. White and J. F. Fellers,
Polym Eng Sci 20, 221 (1980)
28. J. W. Hyatt,
U.S. Patent 204,228 (1878)
29. M. R. Gerow,
U.S. Patent 2,720,680 (1955)
30. M. T. Cichelli,
U.S. Patent 2,987,765 (1961)
31. M. R. Gerow,
U.S. Patent 3,084,386 (1963)
32. E. L. Fallwell,
U.S. Patent 3,092,874 (1963)
33. M. R. Gerow,
U.S. Patent 3,304,352 (1967)
34. F. A. Carlson,
U.S. Patent 3,619,445 (1971)

35. J. F. Flood,
MS Thesis, Polymer Engineering, University of Tennessee (1981)
36. R. B. Bird, W. E. Stewart and E. N. Lightfoot,
"Transport Phenomena" Wiley, N.Y. (1960)
37. J. R. A. Pearson and C. J. S. Petrie,
Plastics and Polymers 38, 85 (1970)
J Fluid Mech 40, 1 (1970) *ibid* 42, 609 (1970)
38. K. J. Choi, J. L. White and J. E. Spruiell,
J Appl Polym Sci 25, 2777 (1980)
39. W. Flugge,
"Stresses in Shells," Springer, Berlin (1960)
40. R. A. Wessling,
Trans Soc Rheology 9, 95 (1965)
41. R. A. Wessling and T. Alfrey,
Trans Soc Rheology 8, 85 (1964)
42. P. A. Gutteridge,
J. Non Newt Fluid Mech 4, 73 (1978)
43. T. Kaneda, S. Ishikana, H. Daimon, T. Katsura, M. Ueda, K. Oda, M. Horio,
Macromolecules (in press)
44. L. E. Alexander,
"X-ray Diffraction Methods in Polymer Science,"
Wiley, N. Y. (1969)
45. K. J. Choi, J. E. Spruiell and J. L. White,
J Polym Sci Polym Phys (in press)
46. J. L. White and J. E. Spruiell,
Polym Eng Sci (in press)
47. M. G. Northolt,
European Polym J 10, 799 (1974)
48. R. S. Stein,
J Polym Sci 31, 327 (1958)
49. K. Haraguchi, T. Kajiyama and M. Takayanagi,
J Appl Polym Sci 23, 915 (1979)
50. K. Matsumoto,
Bull. Fac. Tax. Sci., Kyoto Univ. Tex. Fib., 7 (2), 279 (1974).

TABLE 1
 PROCESS CONDITIONS FOR FORMATION
 OF PPD-T FILMS

Run Number	Coagulant by Volume	Blowup Ratio	Film Process	Temperature °C	Extrusion Rate g/min	Conc wt%	Sample Thickness mm
1	50% MeOH 50% EtOH	1	Extruded	70°	85	17	0.9
2	55% MeOH 45% H ₂ O	1	Extruded	70°	85	17	0.7
3	75% MeOH 25% H ₂ O	1	Extruded	70°	85	17	0.99
4	100% H ₂ O	1	Extruded	70°	85	17	0.92
5	50% MeOH 50% EtOH	<1	Drawdown	70°	85	17	0.06
6	55% MeOH 45% H ₂ O	<1	Drawdown	70°	85	17	0.026
7	75% MeOH 25% H ₂ O	<1	Drawdown	70°	85	17	0.08
8	100% H ₂ O	<1	Drawdown	70°	85	17	0.04
9	50% MeOH 50% MeOH	3.3	Mandrel	70°	85	17	0.012
10	50% MeOH 50% MeOH	3.3	Mandrel	70°	85	17	0.01
11	75% MeOH 25% H ₂ O	3.3	Mandrel	70°	85	17	0.01
12	17% EtOH 25% H ₂ O	3.3	Mandrel	70°	85	17	0.01
13	50% MeOH 50% EtOH	3.3	Mandrel with Drawdown	70°	85	17	0.01

TABLE 2

PRIMARY WAXS REFLECTIONS
FROM PPD-T ACCORDING TO
NORTHOLT (47)

<u>WAXS Reflections</u>	<u>Bragg Spacing, Å</u>	<u>Bragg Angle</u>
110	4.326	20.5°
200	3.935	22.57
006	2.15	41.97

TABLE 3

BIAXIAL ORIENTATION FACTORS FOR FILMS

Run No.	Film Process	f_{1c}^B	f_{2c}^B	f_{1b}^B	f_{2b}^B	f_{1a}^B	f_{2a}^B
1	Extruded	0.33	0.04	-0.19	-0.004	-0.18	-0.04
2	Extruded	0.22	0.04	-0.09	-0.02	-0.14	-0.03
3	Extruded	0.35	0.20	-0.15	-0.09	-0.20	-0.11
4	Extruded	0.30	0.16	-0.15	-0.08	-0.15	-0.08
5	Uniaxial Drawdown	0.51	0.01	-0.23	-0.05	-0.28	-0.04
6	Uniaxial Drawdown	0.52	0.21	-0.23	-0.10	-0.30	-0.11
7	Uniaxial Drawdown	0.40	0.18	-0.17	-0.10	-0.23	-0.08
8	Uniaxial Drawdown	0.46	0.18	-0.17	-0.06	-0.29	-0.11
9	Mandrel	0.21	0.17	-0.04	-0.03	-0.02	-0.14
10	Mandrel	0.16	0.25	-0.03	-0.04	-0.14	-0.21
11	Mandrel	0.23	0.27	-0.59	-0.07	-0.17	-0.20
12	Mandrel	0.35	0.45	-0.12	-0.14	-0.23	-0.31
13	Mandrel with Drawdown	0.27	0.16	-0.07	-0.04	-0.27	-0.13

TABLE 4

SHRINKAGE OF PPD-T FILMS

<u>Coagulant</u>	<u>Film Process</u>	<u>Percent Shrinkage</u>	
		<u>Machine Direction</u>	<u>Transverse Direction</u>
100% H ₂ O	Extruded	73	73
55% MeOH 45% H ₂ O	"	5.4	38
75% MeOH 25% H ₂ O	"	24	33
100% MeOH	"	15	30
100% H ₂ O	Drawdown	0	20
55% MeOH 45% H ₂ O	"	1.3	17
75% MeOH 25% H ₂ O	"	0	28
100% MeOH	"	5.7	30
100% H ₂ O	Mandrel	-	-
55% MeOH 45% H ₂ O	"	-	-
75% MeOH 25% H ₂ O	"	2	0
100% MeOH	"	0	0

TABLE 5.
MECHANICAL PROPERTIES OF PPD-T FILMS

Run No.	Film Coagulant by Volume	Film Process	Modulus 45°		Tensile Strength 45°		
			MD	TD	MD	TD	
1	50% MeOH 50% EtOH	Extruded	1.1X10 ⁹	2.4X10 ⁸	2.9X10 ⁷	7.6X10 ⁶	1.4X10 ⁷
2*	55% MeOH 45% H ₂ O	Extruded	3.8X10 ⁹	broke in* clump	1.2X10 ⁸	--	--
3	75% MeOH 25% H ₂ O	Extruded	2.1X10 ⁸	1.4X10 ⁸	3.1X10 ⁶	2.1X10 ⁶	1.4X10 ⁶
4	100% H ₂ O	Extruded	1.4X10 ⁹	1.1X10 ⁸	9.0X10 ⁷	3.1X10 ⁷	6.2X10 ⁶
5	50% MeOH 50% EtOH	Drawdown	3.3X10 ⁹	1.1X10 ⁹	1.2X10 ⁸	2.3X10 ⁷	6.7X10 ⁷
6	55% MeOH 45% H ₂ O	Drawdown	6.1X10 ⁹	9.0X10 ⁷	1.5X10 ⁸	6.6X10 ⁶	9.0X10 ⁶
7	75% MeOH 25% H ₂ O	Drawdown	3.2X10 ⁹	2.9X10 ⁸	1.2X10 ⁸	7.6X10 ⁶	7.6X10 ⁶
8	100% H ₂ O	Drawdown	8.3X10 ⁹	5.0X10 ⁹	2.5X10 ⁸	1.3X10 ⁸	1.5X10 ⁷
9	50% MeOH 50% EtOH	Mandrel	1.0X10 ⁹	1.5X10 ⁹	4.9X10 ⁷	5.8X10 ⁷	5.5X10 ⁷
10	50% MeOH 50% EtOH	Mandrel	--	--	--	--	--
11	75% MeOH 25% H ₂ O	Mandrel	1.4X10 ⁹	2.6X10 ⁹	6.4X10 ⁷	1.1X10 ⁸	9.2X10 ⁷
12	75% EtOH 25% H ₂ O	Mandrel	8.3X10 ⁸	5.0X10 ⁹	6.6X10 ⁷	9.0X10 ⁷	9.0X10 ⁷
13	50% MeOH 50% EtOH	Mandrel with Drawdown	2.0X10 ⁹	6.8X10 ⁸	9.7X10 ⁷	2.3X10 ⁷	2.7X10 ⁷

*This sample was exceptionally smooth or wrinkle free compared to the other samples. There were slight twists or contortions throughout the sample though, which in combination with the routine brittleness contributed to the sample breaking upon being clamped.

FIGURES

1. Schematic of PPD-T/H₂SO₄ film forming process with mandrel
2. A. Detail of die and mandrel
B. Film in extensional flow over oil lubricated mandrel
3. Photographs of equipment and its operation
 - A. Overview
 - B. Coating of mandrel with oil
 - C. Emergence of PPD-T/H₂SO₄ solution over oil coated mandrel
 - D. Normal operation of process with PPD-T/H₂SO₄ and oil coated mandrel
4. Approximate phase diagram of PPD-T/H₂SO₄ indicating concentration temperature dependence of liquid crystalline regions
5. Polarized light photomicrographs of liquid crystalline PPD-T/H₂SO₄ solutions
 - A. 12% PPD-T at 70°C
 - B. 17% PPD-T at 70°C
6. Pole figures of film extruded through an annular air gap into the coagulation bath
 - A. 200 reflection
 - B. 006 reflection
7. Pole figures for film extruded through an annular die and then drawn down with a drawdown ratio v_1/v_0
 - A. 200 reflection
 - B. 006 reflection
8. Pole figures for film extruded through an annular die and over a mandrel into the coagulation bath
 - A. 200 reflection
 - B. 006 reflection

9. Pole figures for films extruded through an annular die and drawn over a mandrel with higher drawdown ratios
 - A. 200 reflection
 - B. 006 reflection
10. Orientation triangle for C-axis orientation factors
11. SEM photomicrograph of extruded film
 - A. Cross section (50x)
 - B. Surface (100x)
 - C. SURFACE (1000x)
12. SEM photomicrographs of uniaxial drawdown film
 - A. Cross section (1000x)
 - B. Surface (500x)
13. SEM photomicrographs of film extruded over a mandrel
 - A. Cross section (5000x)
 - B. Surface (50x)
14. Polar diagram of modulus as a function of direction in the PPD-T film ($\times 10^{-7}$ pascals)
15. Polar diagram of tensile strength as a function of direction in the PPD-T film ($\times 10^{-7}$ pascals)

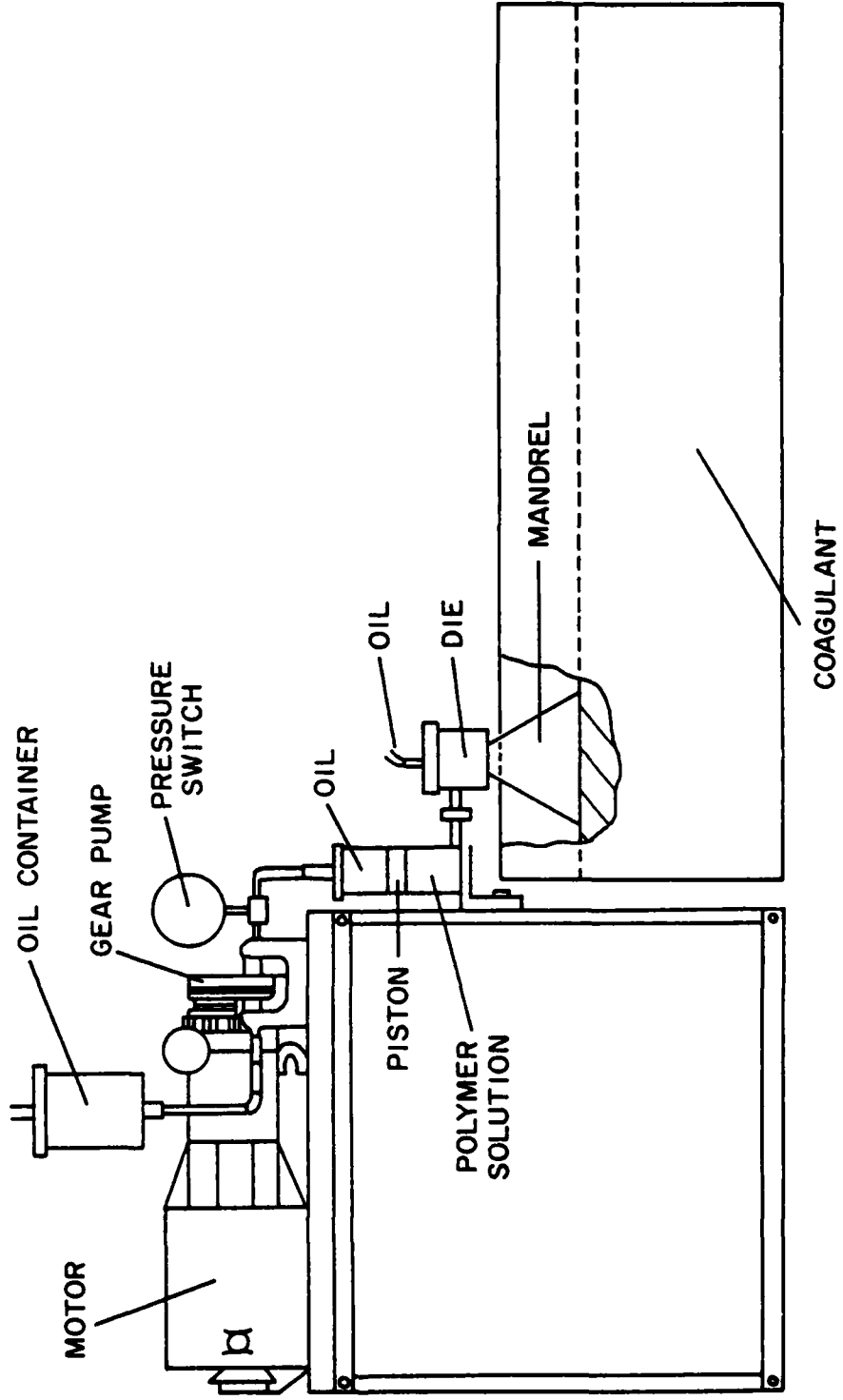

1. SCHEMATIC OF PPD-T/H₂SO₄ FILM FORMING PROCESS WITH MANDREL

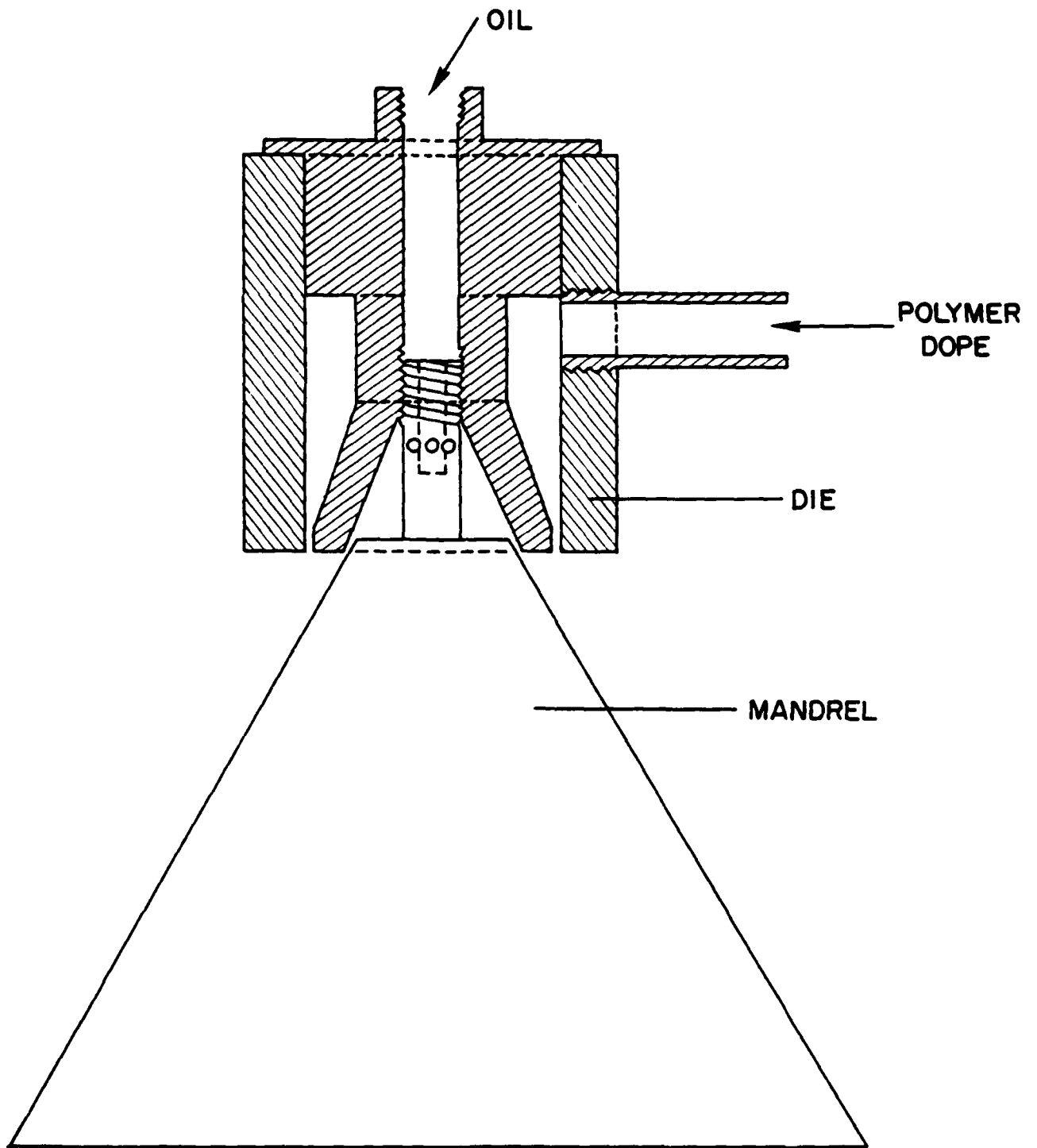

2. (A) DETAIL OF DIE AND MANDREL

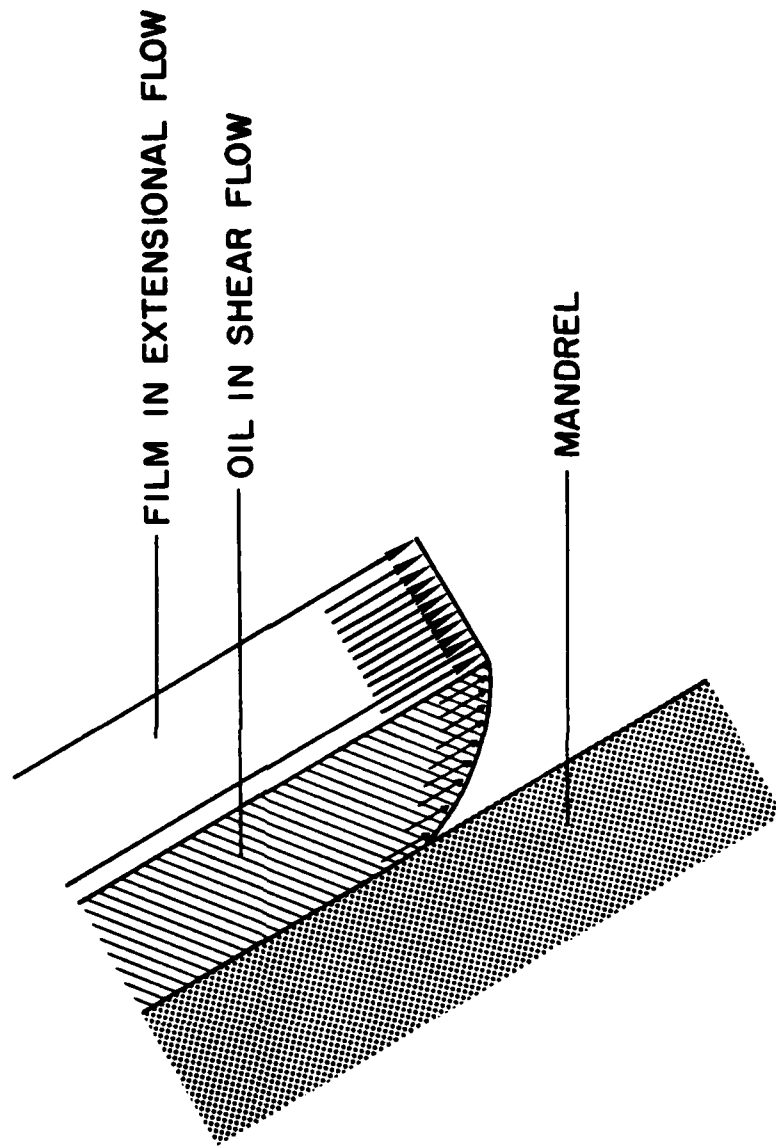

2. (B) FILM IN EXTENSIONAL FLOW OVER OIL LUBRICATED MANDREL

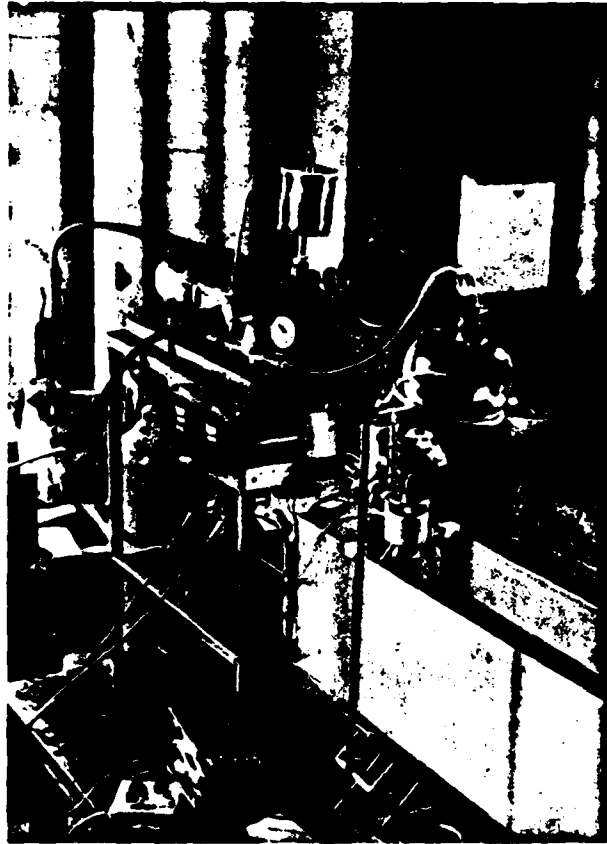

Figure 3(A) Overview of apparatus

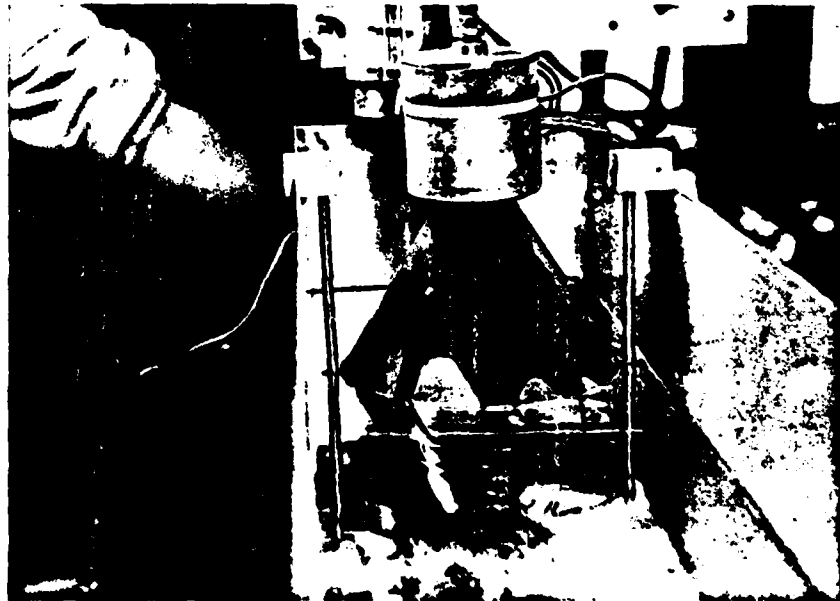

Figure 3(B) Coating of mandrel with oil

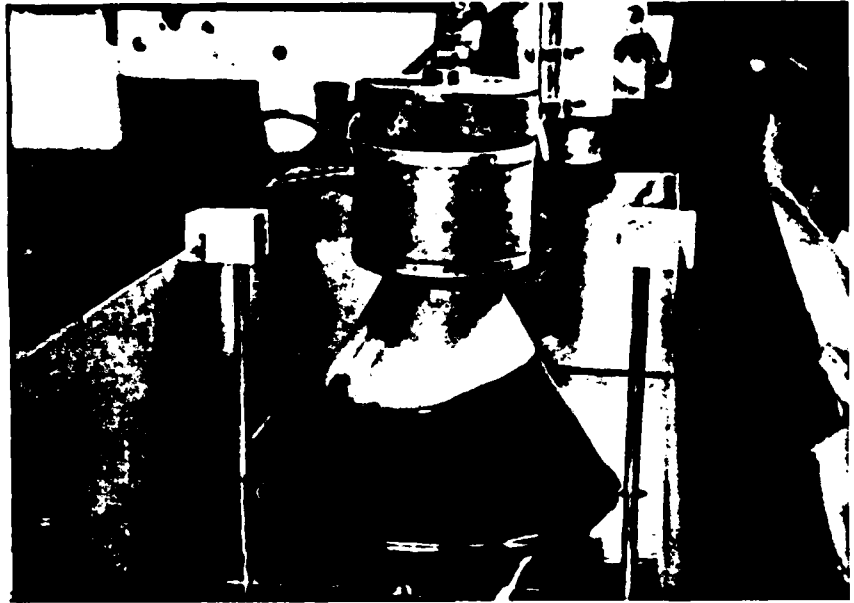

Figure 3 (C) Emergence of PPD-T/H₂SO₄ solution over oil coated mandrel

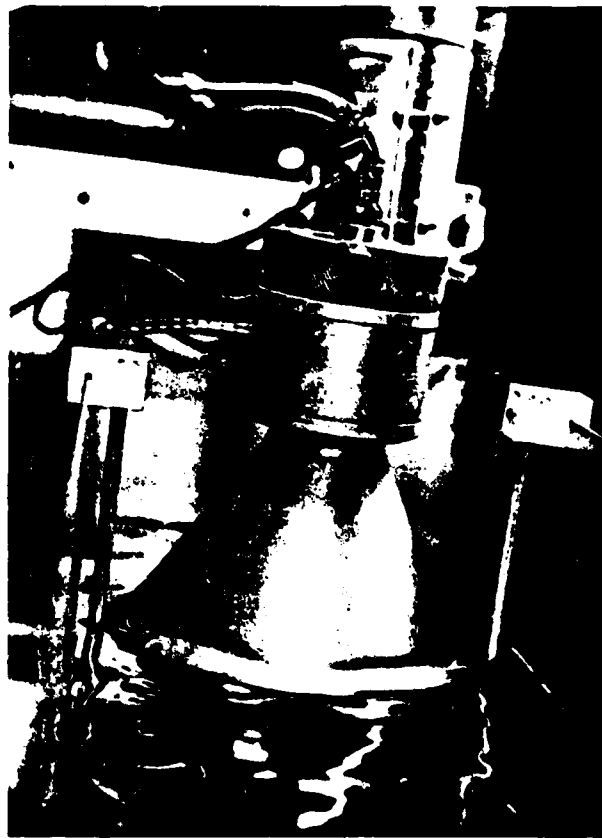
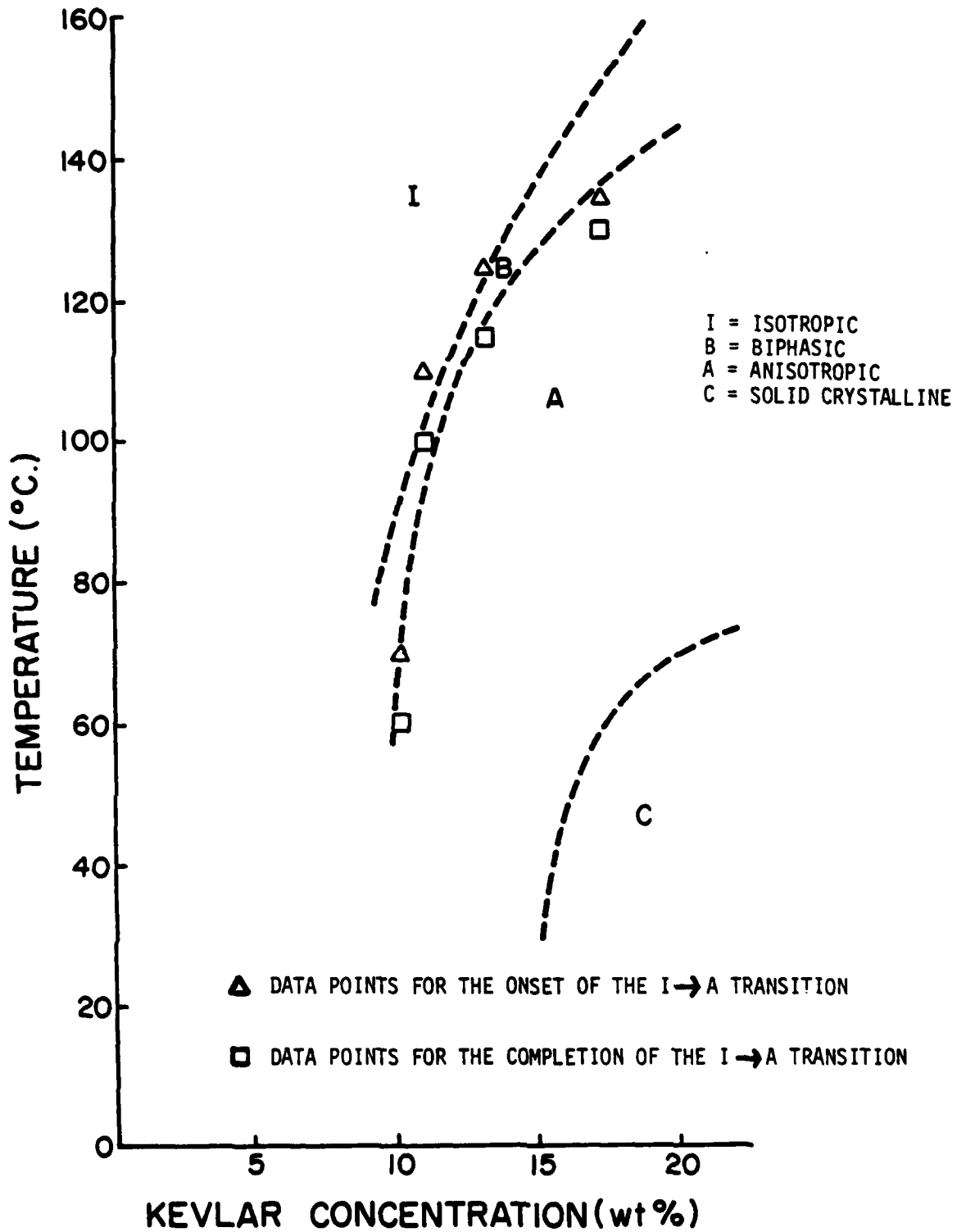

Figure 3 (D) Normal operation of process with PPD-T/H₂SO₄ and oil coated mandrel

FIGURE 3. PHOTOGRAPHS OF EQUIPMENT AND ITS OPERATION



4. APPROXIMATE PHASE DIAGRAM OF PPD-T/H₂SO₄ INDICATING CONCENTRATION TEMPERATURE DEPENDENCE OF LIQUID CRYSTALLINE REGIONS



5. POLARIZED LIGHT PHOTOMICROGRAPHS OF LIQUID CRYSTALLINE PPD-T/H₂SO₄ SOLUTIONS

(A) 12% PPD-T at 70°C

(B) 17% PPD-T at 70°C

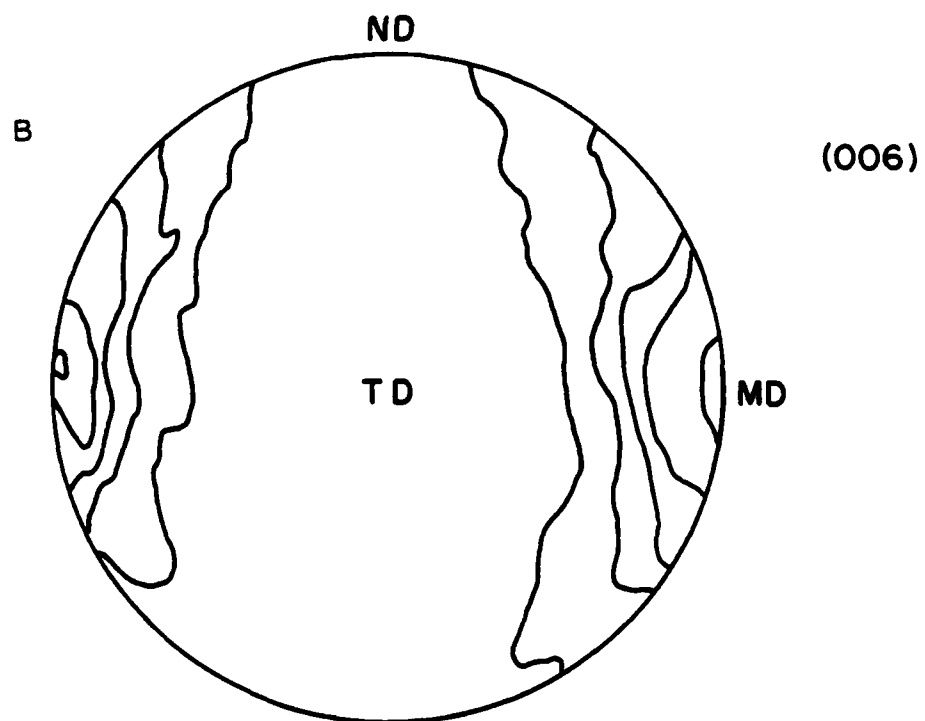
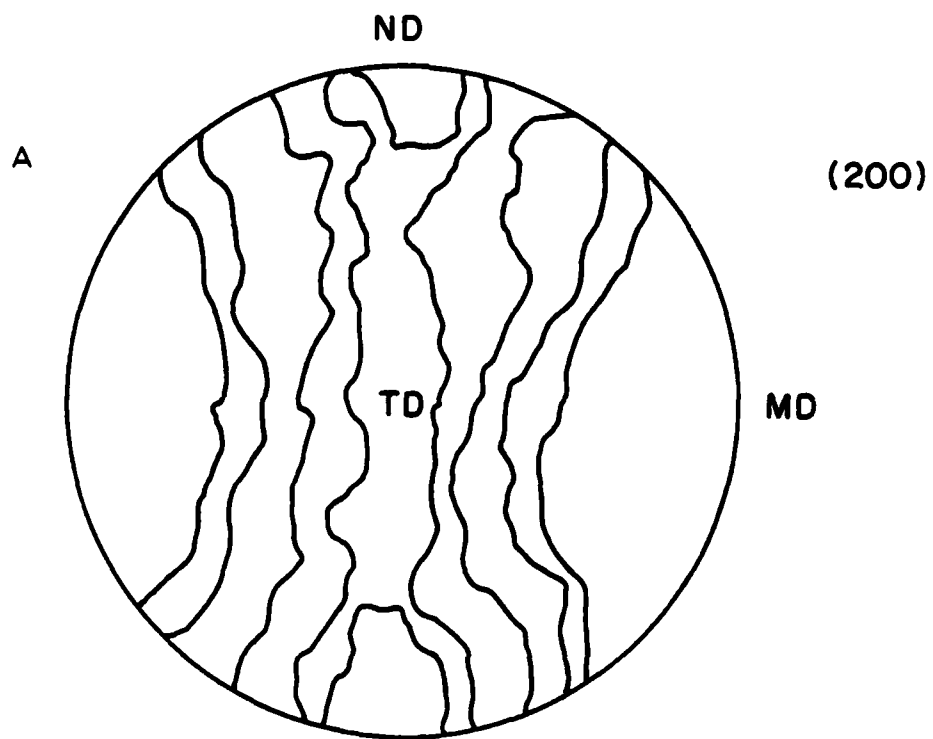

6. POLE FIGURES OF FILM EXTRUDED THROUGH AN ANNULAR AIR GAP INTO THE COAGULATION BATH

(A) 200 REFLECTION
 (B) 006 REFLECTION

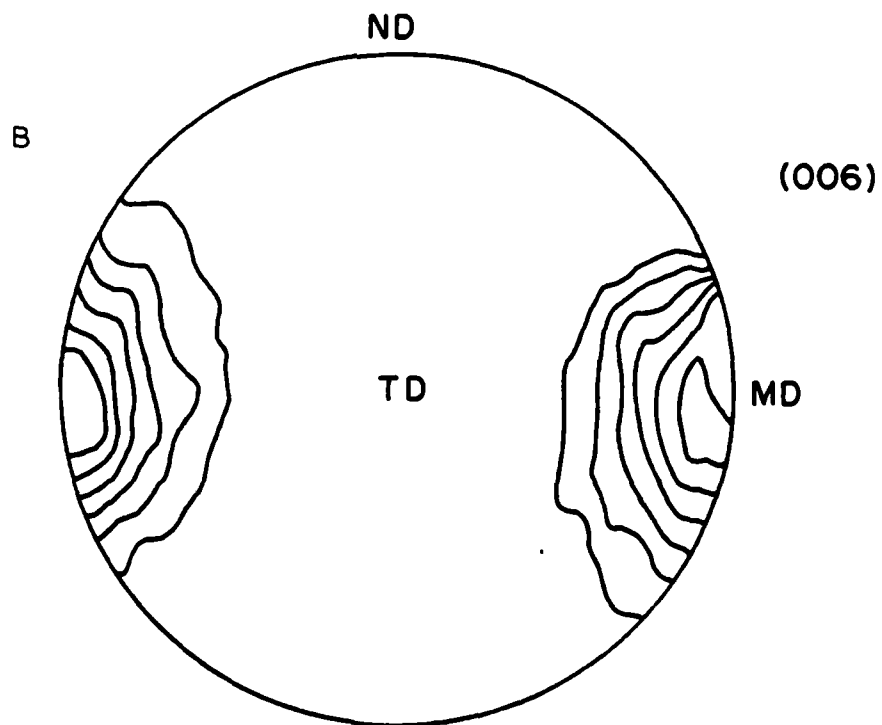
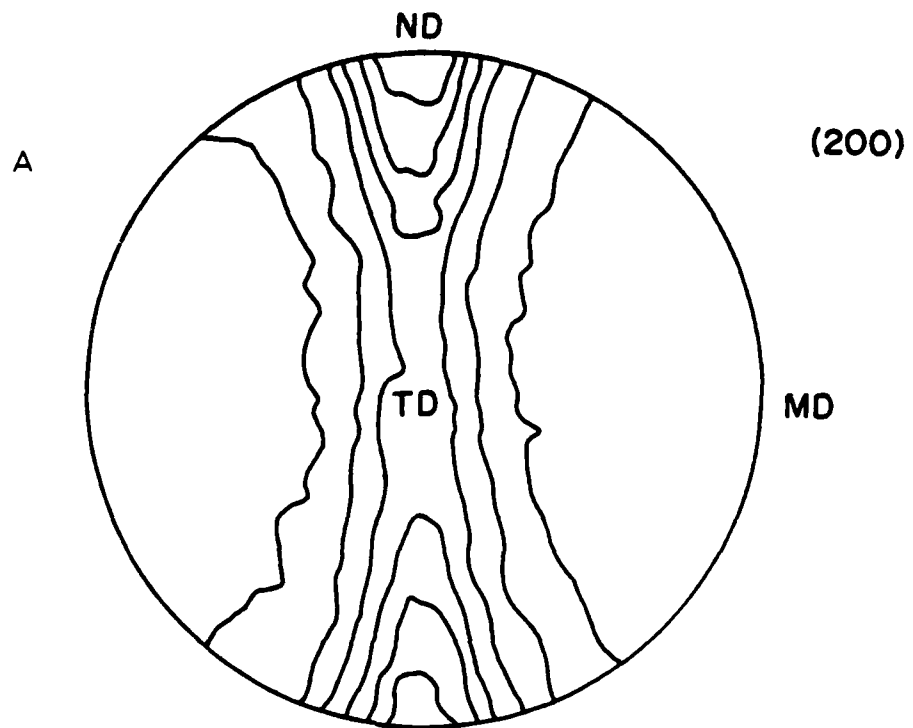

7. POLE FIGURES FOR FILM EXTRUDED THROUGH AN ANNULAR DIE AND THEN DRAWN DOWN WITH A DRAWDOWN RATIO V_1/V_0

- (A) 200 REFLECTION
- (B) 006 REFLECTION

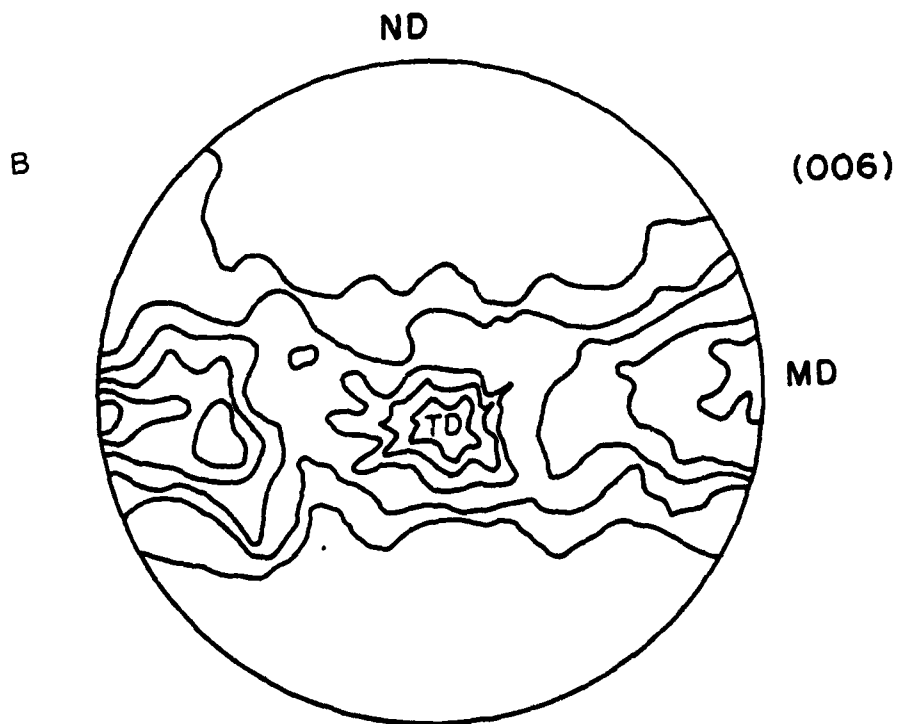
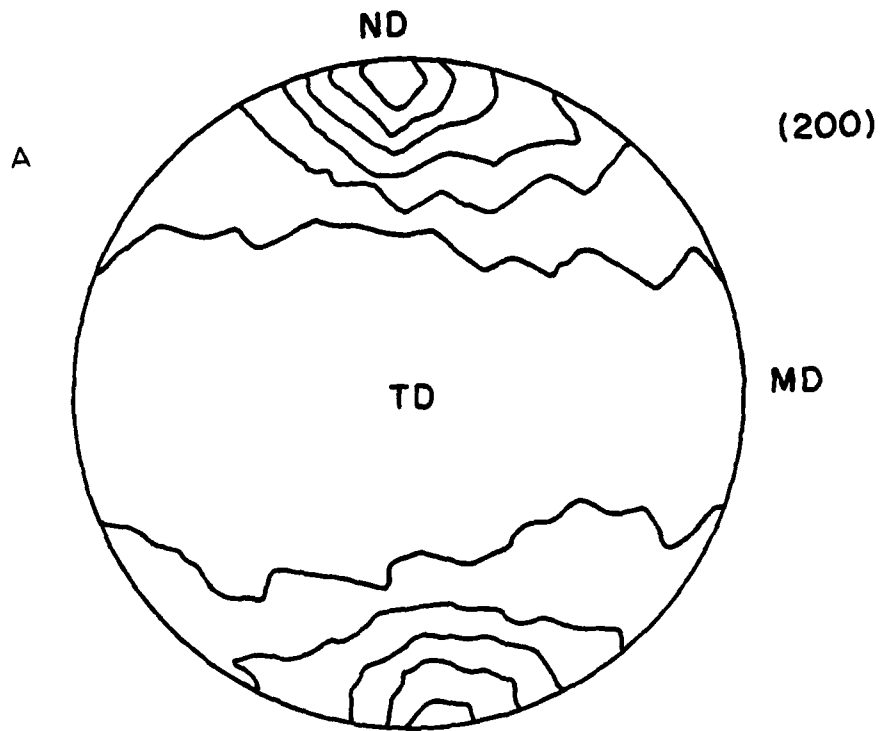

8. POLE FIGURES FOR FILM EXTRUDED THROUGH AN ANNULAR DIE AND OVER A MANDREL INTO THE COAGULATION BATH

- (A) 200 REFLECTION
- (B) 006 REFLECTION

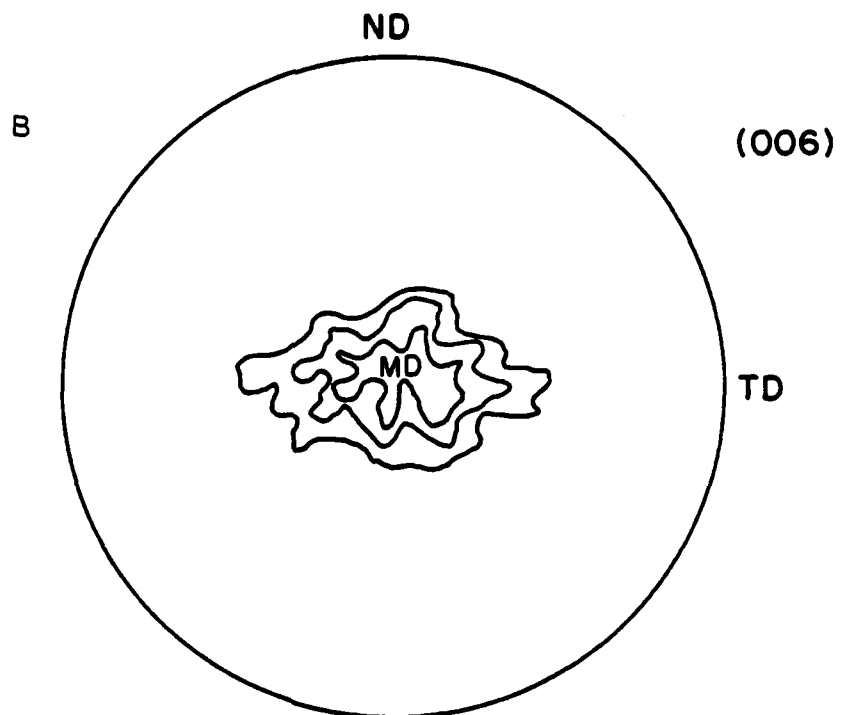
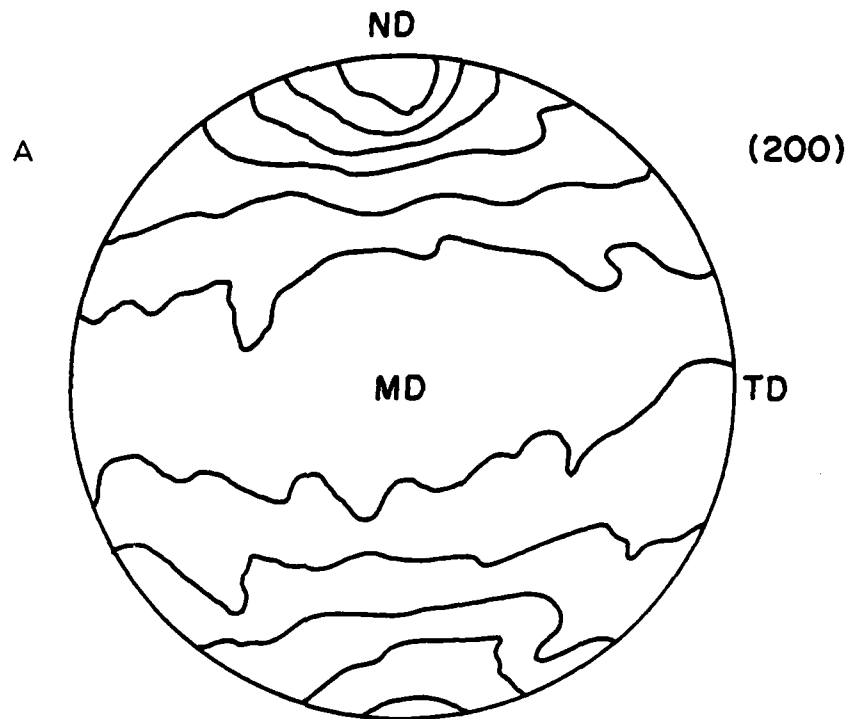

9. POLE FIGURES FOR FILMS EXTRUDED THROUGH AN ANNULAR DIE AND DRAWN OVER A MANDREL WITH HIGHER DRAWDOWN RATIOS

(A) 200 REFLECTION
 (B) 006 REFLECTION

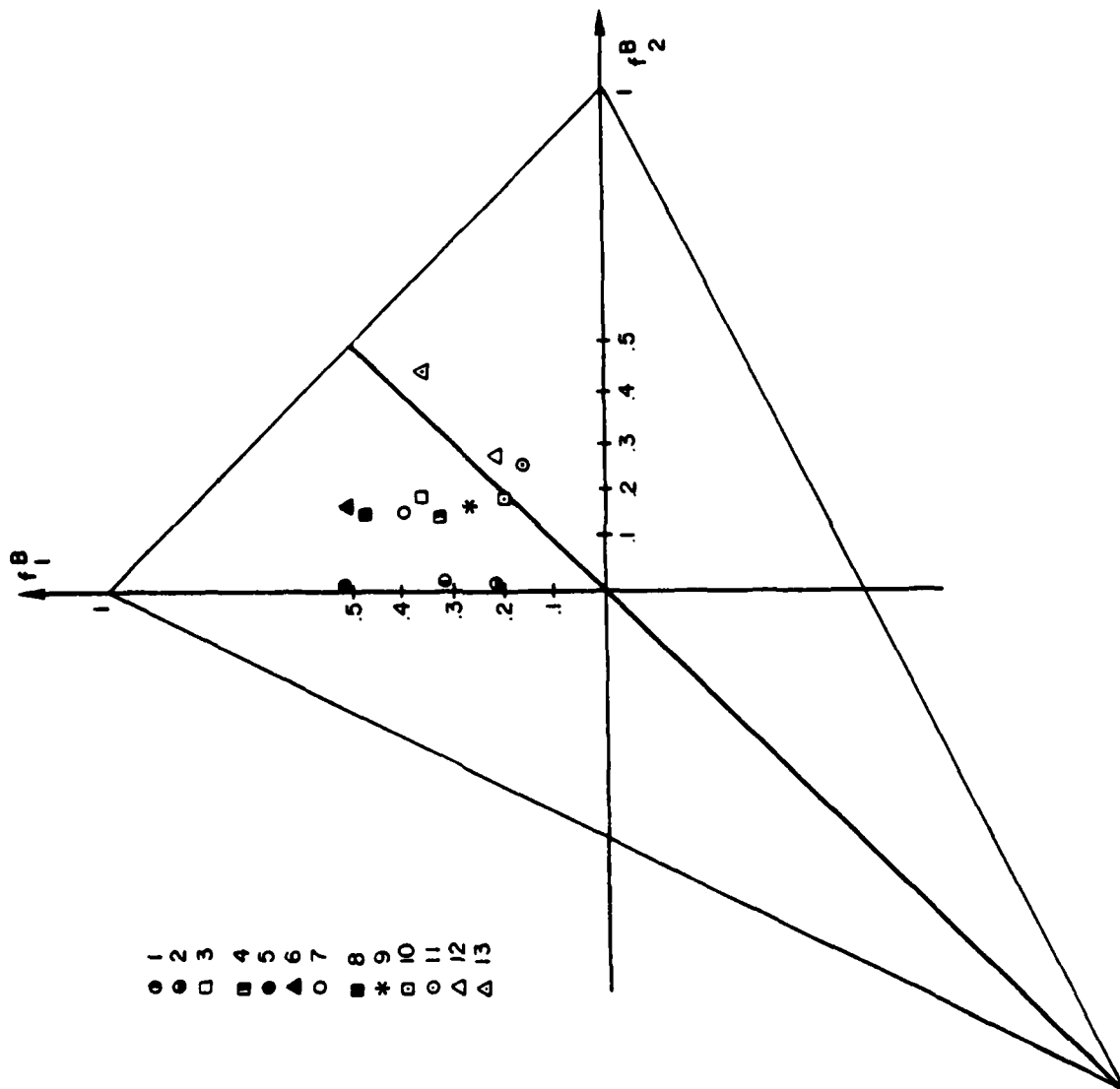

10. ORIENTATION TRIANGLE FOR C-AXIS ORIENTATION FACTORS

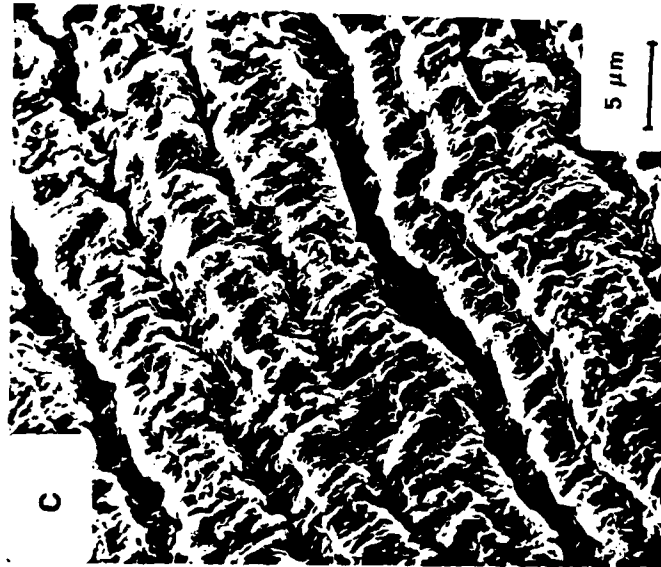
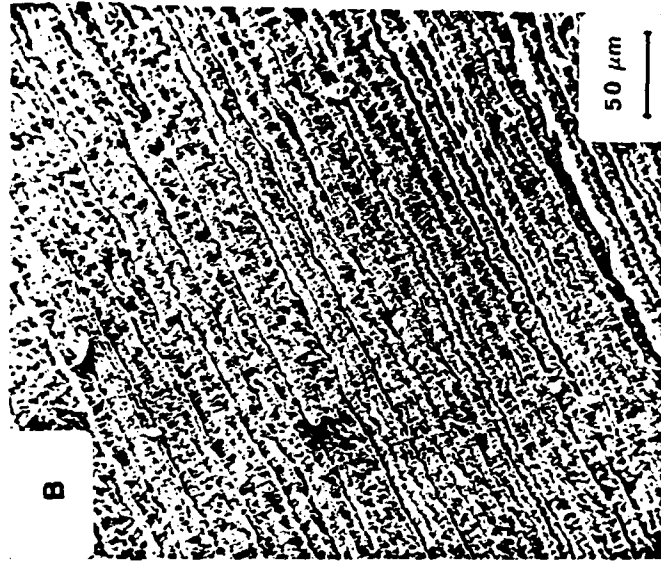
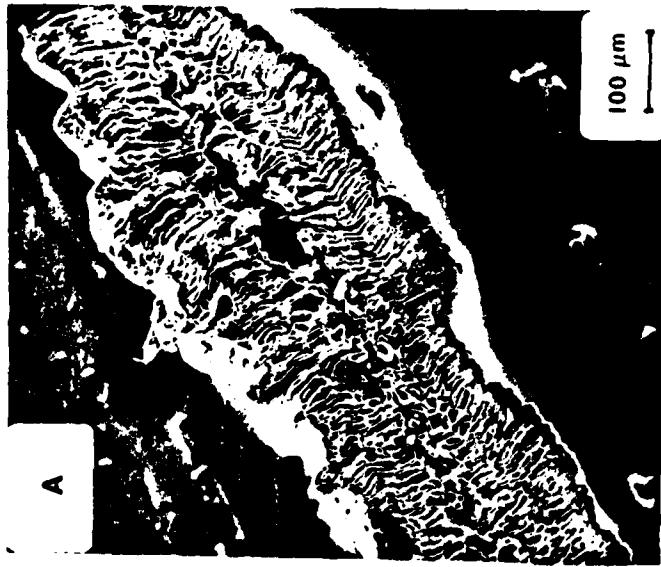

11. SEM PHOTOMICROGRAPH OF EXTRUDED FILM

(A) CROSS SECTION (50x)

(B) SURFACE (100x)

(C) SURFACE (1000x)

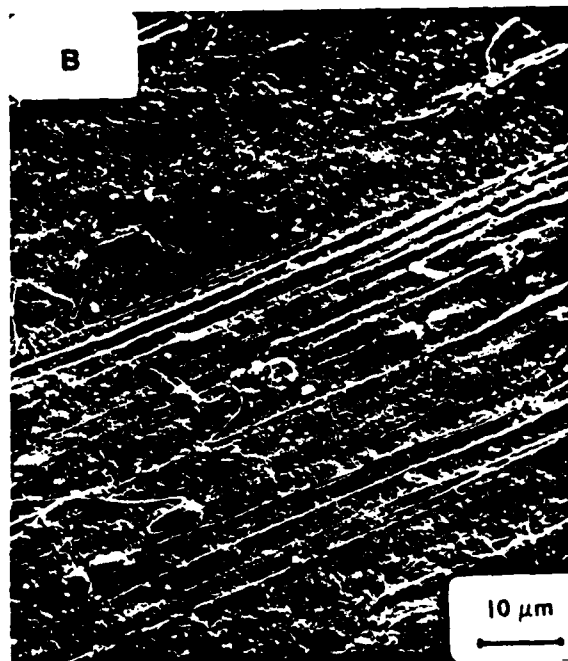

12. SEM PHOTOMICROGRAPHS OF UNIAXIAL DRAWDOWN FILM

(A) CROSS SECTION (1000x)

(B) SURFACE (500x)



13. SEM PHOTOMICROGRAPHS OF FILM EXTRUDED OVER A MANDREL

(A) CROSS SECTION (5000x)

(B) SURFACE (50x)

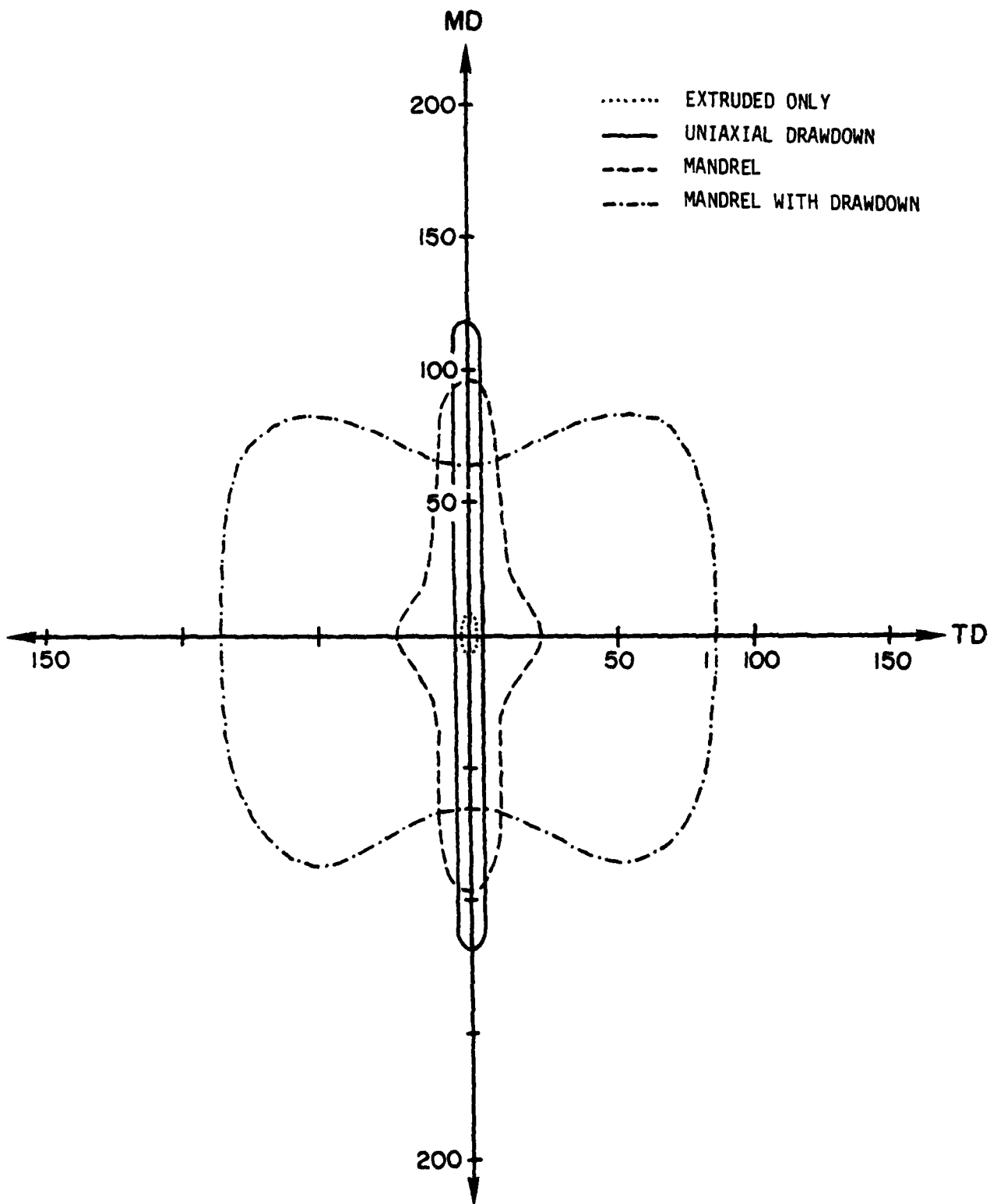

14. POLAR DIAGRAM OF MODULUS AS A FUNCTION OF DIRECTION IN THE PPD-T FILM
($\times 10^{-7}$ PASCALS)

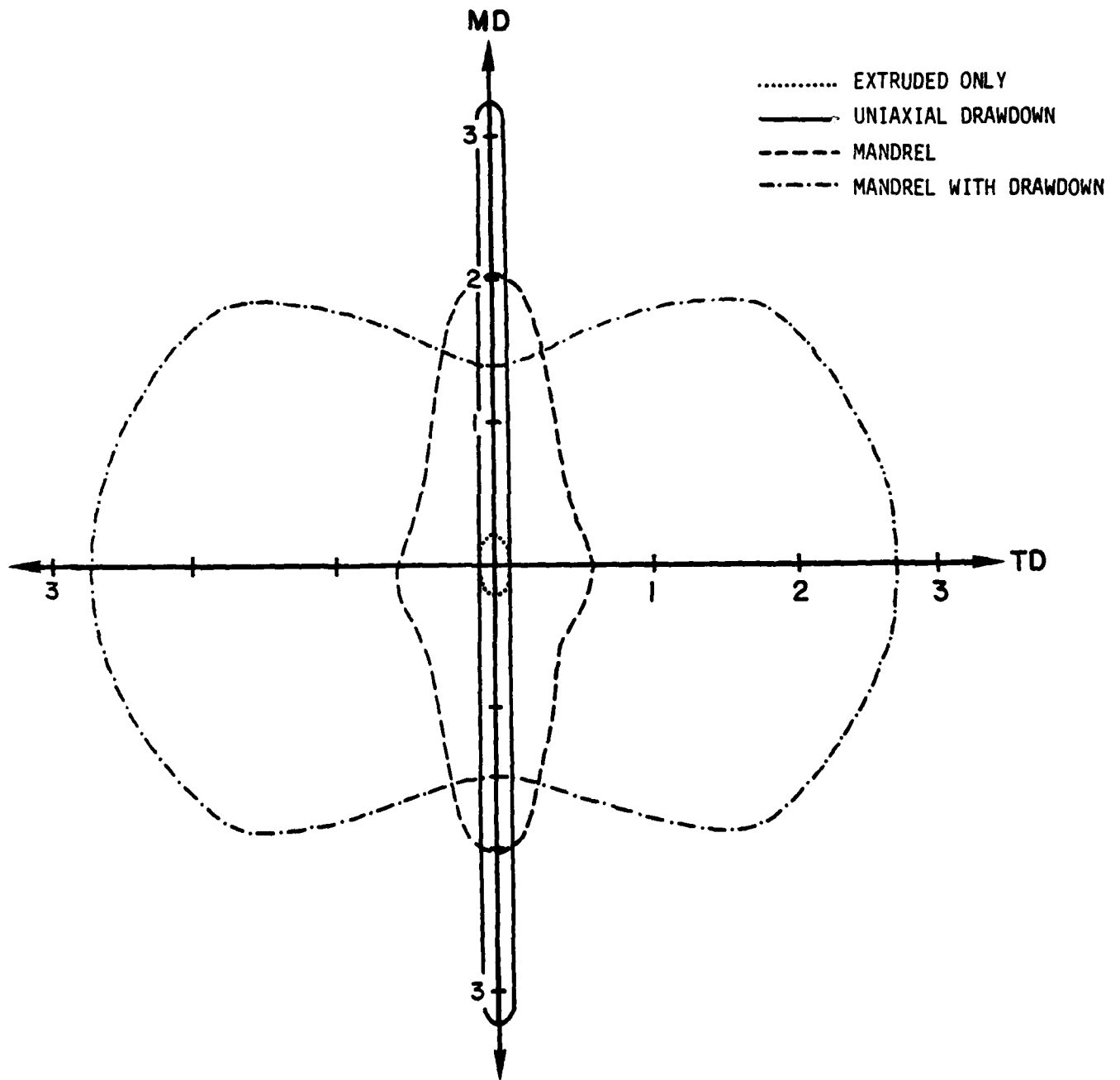

15. POLAR DIAGRAM OF TENSILE STRENGTH AS A FUNCTION OF DIRECTION IN THE PPD-T FILM ($\times 10^{-7}$ PASCALS)

**DAT
FILM**