

MICROCOPY RESOLUTION TEST CHART
NATIONAL BUREAU OF STANDARDS 1963-A

Report No. CG-1-81

K 19
US

12

LEVEL II

AD A108059

TESTING OF PORTABLE
FIRE EXTINGUISHERS FOR
MOTORBOATS

T. LAZZELLE
E. ENSERINK



Prepared by:

DYNAMIC SCIENCE, INC.
A TALLEY INDUSTRIES COMPANY
1850 WEST PINNACLE PEAK ROAD
PHOENIX, ARIZONA 85027

Prepared by:

U.S. DEPARTMENT OF TRANSPORTATION
UNITED STATES COAST GUARD
OFFICE OF MERCHANT MARINE SAFETY
WASHINGTON, D.C. 20593

DTIC
ELECTE
DEC 2 1981
S D D

81 12 02 026

NOTICE

This document is disseminated under the sponsorship of the Department of Transportation in the interest of information exchange. The United States Government assumes no liability for the contents or use thereof.

Prepared for the Department of Transportation, U.S. Coast Guard,
under Contract No. DOT-CG-832600-A. This document is disseminated
under the sponsorship of the Department of Transportation in the
interest of information exchange. The United States Government
assumes no liability for the contents or use thereof.

(18) USCG-M (19) 1-81

TECHNICAL REPORT STANDARD TITLE PAGE

1. Report No.	2. Government Accession No. AD-A108059	3. Recipient's Catalog No.	
4. Title and Subtitle TESTING OF PORTABLE FIRE EXTINGUISHERS FOR MOTORBOATS.	(11)	5. Report Date OCT 1979	6. Performing Orgn Code
7. Author(s) T. Lazzelle / E. Enserink	(14)	8. Performing Orgn Rpt No. 8328-80-092	9. Work Unit No.
9. Performing Organization Name and Address Dynamic Science, Inc. A Talley Industries Company 1850 West Pinnacle Peak Road Phoenix, Arizona 85027	(15)	11. Contract or Grant No. DOT-CG-832600-A	13. Type of Report and Period Covered Final Report
12. Sponsoring Agency Name and Address U.S. Department of Transportation United States Coast Guard Washington, D.C. 20590	(12) 37	(9)	14. Sponsoring Agency Code
15. Supplementary Notes			
16. Abstract A study has been made of the relative effectiveness of eleven small hand-portable fire extinguishers (using six different extinguishing agents) considered suitable for fighting fires of flammable liquids. The evaluation was based on the performance of the extinguishers on seven fire models and three fuels. The fire models were selected either because they were standard extinguisher tests or simulated possible conditions of hazards on small motorboats. The relative merit of the fire models as extinguisher tests was evaluated. Also, the effectiveness of the several extinguisher types on the fires and fuels was evaluated and recommendations made for updating Tables in 46 CFR §25.			
17. Key Words Portable Fire Extinguishers, Motorboat Fires, Fire Extinguisher Effectiveness, Coast Guard Regulations Fire Extinguishing Agents		18. Distribution Statement Copies available through the National Technical Information Service, Springfield, Virginia 22161	
19. Security Classif. (of this report) Unclassified	20. Security Classif. (of this page) Unclassified	21. No. Pages 36	22. Price

407293

Qui!

METRIC CONVERSION FACTORS

Approximate Conversions to Metric Measures

Symbol	When You Know	Multiply by	To Find	Symbol
LENGTH				
in	inches	2.5	centimeters	cm
ft	feet	30	centimeters	cm
yd	yards	0.9	meters	m
mi	miles	1.6	kilometers	km
AREA				
in ²	square inches	6.5	square centimeters	cm ²
ft ²	square feet	0.09	square meters	m ²
yd ²	square yards	0.8	square meters	m ²
mi ²	square miles	2.6	square kilometers	km ²
acres	acres	0.4	hectares	ha
MASS (weight)				
oz	ounces	28	grams	g
lb	pounds	0.45	kilograms	kg
	short tons (2000 lb)	0.9	metric ton	t

VOLUME				
tsp	teaspoons	5	milliliters	ml
Tbsp	tablespoons	15	milliliters	ml
in ³	cubic inches	16	milliliters	ml
fl oz	fluid ounces	30	milliliters	ml
c	cups	0.24	liters	L
pt	pints	0.47	liters	L
qt	quarts	0.95	liters	L
gal	gallons	3.8	liters	L
ft ³	cubic feet	0.03	cubic meters	m ³
yd ³	cubic yards	0.76	cubic meters	m ³

TEMPERATURE (exact)		
°F	degrees Fahrenheit	subtracting 32)
°C	degrees Celsius	

Approximate Conversions from Metric Measures

Symbol	When You Know	Multiply by	To Find	Symbol
LENGTH				
mm	millimeters	0.04	inches	in
cm	centimeters	0.4	inches	in
m	meters	3.3	feet	ft
m	meters	1.1	yards	yd
km	kilometers	0.6	miles	mi
AREA				
cm ²	square centimeters	0.16	square inches	in ²
m ²	square meters	1.2	square yards	yd ²
km ²	square kilometers	0.4	square miles	mi ²
ha	hectares (10 000 m ²)	2.5	acres	

MASS (weight)				
g	grams	0.035	ounces	oz
kg	kilograms	2.2	pounds	lb
t	metric ton (1000 kg)	1.1	short tons	

VOLUME				
ml	milliliters	0.03	fluid ounces	fl oz
ml	milliliters	0.06	cubic inches	in ³
L	liters	2.1	pints	pt
L	liters	1.06	quarts	qt
L	liters	0.26	gallons	gal
m ³	cubic meters	35	cubic feet	ft ³
m ³	cubic meters	1.3	cubic yards	yd ³

TEMPERATURE (exact)		
°C	degrees Celsius	9 5 (then add 32)
°F	degrees Fahrenheit	

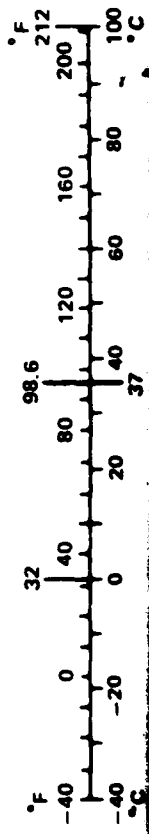
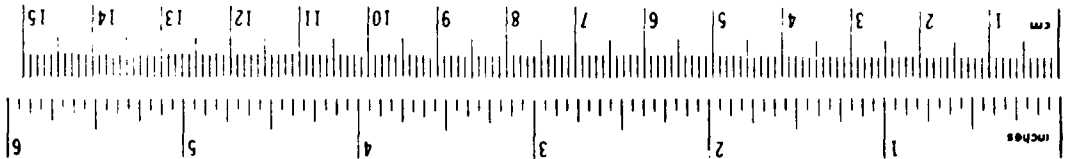

TABLE OF CONTENTS

	<u>Page</u>
1.0 INTRODUCTION AND SUMMARY	1
2.0 DESCRIPTION OF TEST EXTINGUISHERS AND AGENTS	3
3.0 DESCRIPTION OF TEST METHODS	8
4.0 DISCUSSION OF FUELS	19
5.0 RESULTS	20
6.0 DISCUSSION OF RESULTS AND ANALYSIS	25
6.1 RANKING OF TEST FIRES	25
6.2 GENERAL OBSERVATIONS	28
6.3 INFLUENCE OF AMBIENT CONDITIONS ON THE RESULTS	28
7.0 CONCLUSIONS AND RECOMMENDATIONS	29

LIST OF ILLUSTRATIONS

<u>Figure</u>		<u>Page</u>
2-1	Recharging of Halon	6
2-2	Test Fire Extinguishers	7
3-1	Fire Model 1 (Open Spill)	11
3-2	Fire Model 2 (Bilge)	12
3-3	Fire Model 3 (Fuel Saturated Paper)	13
3-4	Fire Model 4 (Open Ended Engine Compartment)	14
3-5	Fire Model 6 (Power Ventilated Engine Compartment)	15
3-6	Fire Model 6 (Open-top, Fiberglass Lined Engine Compartment)	16
3-7	Fire Model 7 (Open-top and End Engine Compartment)	17
3-8	Data Sheet - Motorboat Fire Test Data	18

LIST OF TABLES

<u>Tables</u>	<u>Page</u>
1-1 Table 25.30-10(c) From CFR 46 Showing Examples of Size Gradations for Typical Hand Portable Extinguishers	2
1-2 Table 25.30-20(a) (1) From CFR 46 Showing Minimum Number of Hand Portable Extinguishers Required for Various Sizes of Motor Boats	2
2-1 Extinguishers Tested	5
4-1 Properties of Test Fuels	19
5-1 Heptane Fuel Sum of Scores Obtained by the 11 Extinguishers on Each of the 7 Fire Models (Sum of Four Runs)	22
5-2 Gasoline Fuel Scores Obtained by the 11 Extinguishers on Each of the 7 Fire Models (One Run)	23
5-3 Diesel Fuel Scores Obtained by the 11 Extinguishers on Each of the 7 Fire Models (One Run)	24
6-1 Fire Model Ranking	27
7-1 Proposed Modifications to Table 25.30-10 (C)	30

Accession For	
NTIS GRA&I	<input checked="" type="checkbox"/>
DTIC TAB	<input type="checkbox"/>
Unannounced	<input type="checkbox"/>
Justification	
By _____	
Distribution/	
Availability Codes	
Dist	Avail and/or Special
A	

DTIC
SELECTE
S DEC 2 1981 **D**
D

1.0 INTRODUCTION AND SUMMARY

This document comprises the Dynamic Science, Inc. final report for performing the work specified in the U.S. Coast Guard Contract No. DOT-CG-832600-A entitled "Testing of Portable Fire Extinguishers."

The objective of this program was to provide a data base for updating Coast Guard regulations for portable fire extinguishers for motorboats. Tables 25.30-10 (c) and 25.30-20 (a) (1), 46 Code of Federal Regulations (see Tables 1-1 and 1-2), specify the minimum number and type of fire extinguishers to be carried and the amount of each extinguishing agent required. The tables presently contained in the regulations are out of date since they include obsolete agents no longer produced and do not include the newer agents. Second, the tables do not specify the minimum amount of agent for each size category, and third, there is reason to believe that the different types of extinguishers (e.g., CO₂, dry chemical) contained in the same category (size 1, 2, etc.) vary considerably in extinguishing potential from one another so that substitution of one unit with a differently charged unit of the same size classification may drastically affect the fire protection offered a particular vessel. Fourth, before the newer extinguishing agents can be included in Table 25.30-10 (c), a data base for classification of these units is needed.

The results of this study provide the basis for determining how motorboat regulations should be revised to include new extinguishing media, delete obsolete material, specify minimum weights for each agent category, and more closely reflect the relative fire extinguishing capabilities of each agent classification.

TABLE 1-1. TABLE 25.30-10(c) FROM CFR 46 SHOWING EXAMPLES OF SIZE GRADATIONS FOR TYPICAL HAND PORTABLE EXTINGUISHERS

TABLE 25.30-10(c)

Classification		Foam. gallons	Carbon Dioxide, pounds	Dry chemi- cal, pounds
Type	Size			
B	I	1 $\frac{1}{4}$	4	2
B	II	2 $\frac{1}{4}$	15	10
B	III	12	35	20

TABLE 1-2. TABLE 25.30-20(a)(1) FROM CFR 46 SHOWING MINIMUM NUMBER OF HAND PORTABLE EXTINGUISHERS REQUIRED FOR VARIOUS SIZES OF MOTOR BOATS

TABLE 25.30-20(a)(1)

Class of mo- tor boat	Length, feet	Minimum number of B-I hand port- able fire extin- guishers required. ¹	
		No fixed fire ex- tinguish- ing system in ma- chinery space	Fixed fire extin- guishing system in ma- chinery space
A	Under 16.....	1	0
1	16 and over, but under 26.	1	0
2	26 and over, but under 40.	2	1
3	40 and over, but not over 65.	3	2

¹One B II hand portable fire extinguisher may be substituted for two B-I hand portable fire extinguishers.

2.0 DESCRIPTION OF TEST EXTINGUISHERS AND AGENTS

The eleven extinguishers chosen for these tests were all readily obtainable commercial makes. Each has an Underwriter's Laboratories rating of class BC except the AFFF which is rated AB. All were new and were chosen to determine the effect on extinguishment of agent, capacity, discharge rate or volume, and range of discharge. Extinguishers were chosen from four manufacturers, and four local distributors were used to obtain the desired type of agent and extinguisher. The extinguishers were charged with standard materials, which, where applicable, met the requirements of Federal specifications. A list of the test extinguishers, together with the UL and Coast Guard rating for each is shown in Table 2-1. It should be noted that AFFF and Halon 1301 do not carry a Coast Guard Rating.

AFFF and ammonium phosphate dry chemical test extinguishers were rated "A" (for paper and cellulose). Fire model three is a Class A fire and one on which AFFF was solely and consistently effective.

Size and type are designations referenced in 46 CFR, 25.30-10. Size I was assigned by the respective manufacturers to both the 2.5- and 5-pound extinguishers when used on type BC fires. In addition, Type A, Size II was assigned by the manufacturer to the 4.25 lb ammonium phosphate.

All extinguishers were recharged after each use regardless of the amount of agent expended. Recharging was done by a vendor other than those supplying the extinguishers. The extinguisher using light water, AFFF, was recharged by DSI personnel using the

manufacturer's (3M Corp.) RC 25 recharge kit. The charge consists of 1 pint liquid (RC 25) in 2-1/4 gallons of water at 100 psig air. Table 2-1 gives the operating pressures for all eleven extinguishers. A drawing of the Halon refilling techniques is shown in Figure 2-1 and a picture of all eleven extinguishers is presented in Figure 2-2.

TABLE 2-1. EXTINGUISHERS TESTED

Number	Rating (as indicated on label)		Type	Coast Guard Size	Description Extinguishing Agent	Charge Pressure	Propellant
	UL						
1	10-B : C	B : C	B : C	I	2.5 lb Sodium Bicarbonate	195 psi	N ₂
2	10-B : C	B : C	B : C	I	5 lb Sodium Bicarbonate	195 psi	N ₂
3	1-A:10-B:C	B : C	B : C	I	2.5 lb Ammonium Phosphate	195 psi	N ₂
4	2-A:10-B:C	A,B : C	A,B : C	II, I	4.25 lb Ammonium Phosphate (Cartridge)	200 psi	CO ₂
5	10-B : C	B : C	B : C	I	2.5 lb Purple K Potassium Bicarbonate	195 psi	N ₂
6	60-B : C	B : C	B : C	I	6 lb Purple K Potassium Bicarbonate	195 psi	N ₂
7	5-B : C	B : C	B : C	I	5 lb CO ₂ Carbon Dioxide	Self	Self
8	5-B : C	B : C	B : C	I	2.5 lb Halon 1211 Bromochlorodifluoromethane	125 psi	N ₂
9	10-B : C	B : C	B : C	I	5 lb Halon 1211 Bromochlorodifluoromethane	125 psi	N ₂
10	2-B : C	Not Rated	Not Rated		2.5 lb Halon 1301 Bromotrifluoromethane	199 psi	Self
11	3-A:20-B	Not Rated	Not Rated		AFFF Pressurized Water 2.5 Gallon	100 psi	Air

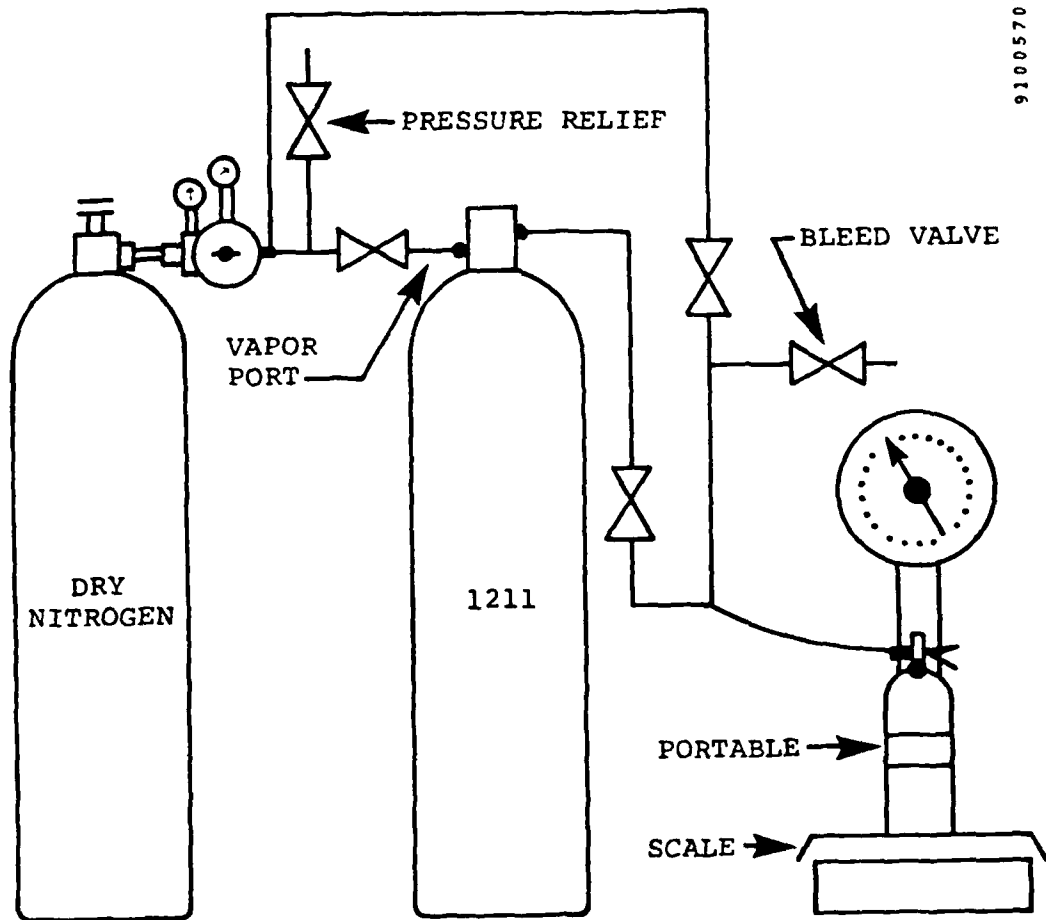

91005701

RECHARGING

Figure 2-1. Recharging of Halon.

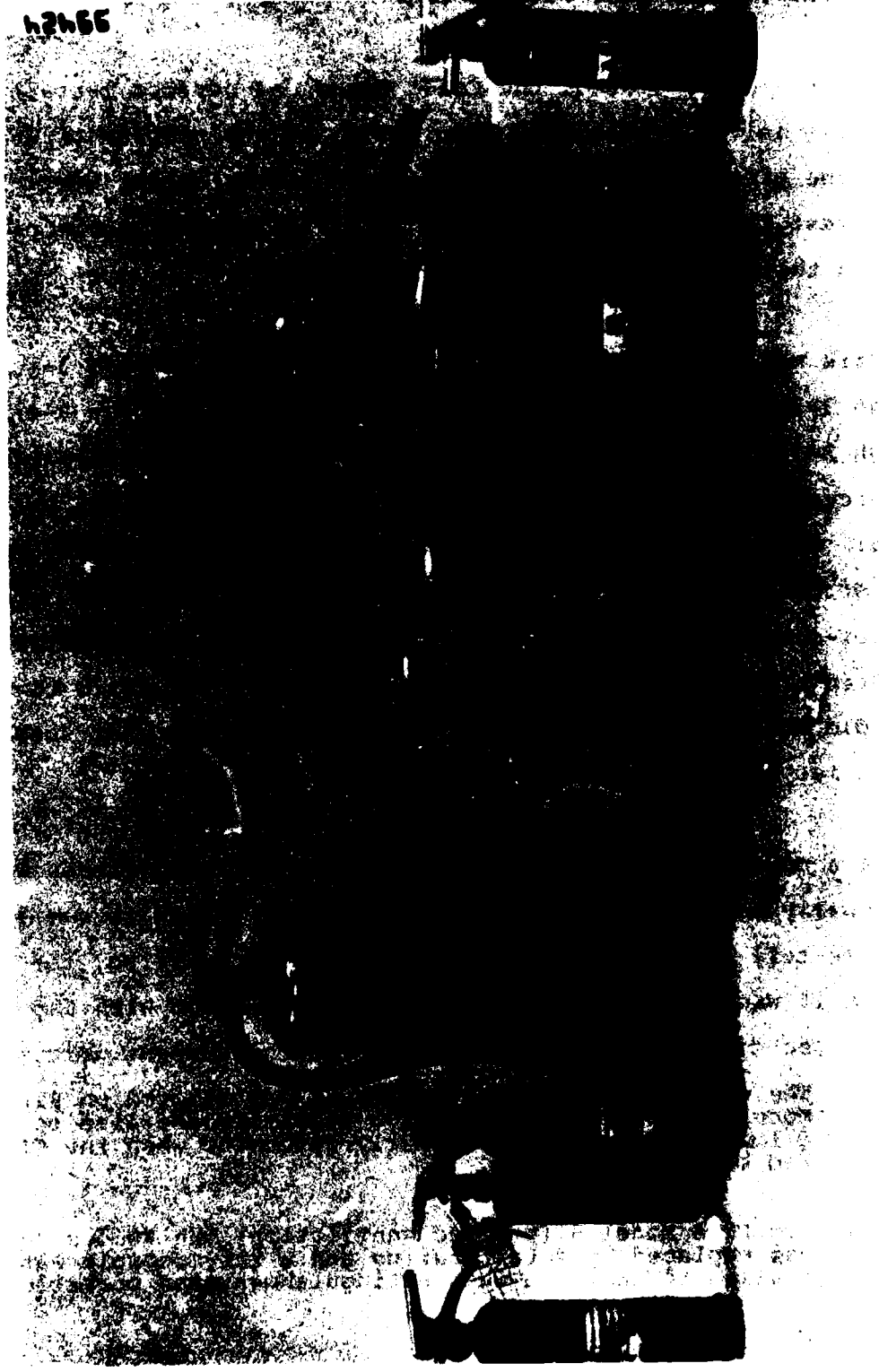

Figure 2-2. Test Fire Extinguishers.

3.0 DESCRIPTION OF TEST METHODS

As previously stated, the Coast Guard had devised certain test fires in its preliminary examination of the problem of determining the effectiveness of extinguishers for motorboat use. Each of the test fires together with all pertinent data is shown pictorially in the diagrams on the following 10 pages.

Fire models 1 through 3 were open fires (see Figures 3-1 through 3-3), and Fire models 4, 5, 6, and 7 (see Figures 3-4 through 3-7) were engine compartment simulation fires designed to limit accessibility to the flames and provide some confinement of vapors. Changes in engine compartment openings were made by removal of the end plates. Fire Model 6 was lined with five layers of fiber-glass cloth bonded with a readily available polyester resin (Standard Brands Polyester A-1 Boat Resin). The resin container label did not indicate the resin to be fire retardant nor specify that it met specific standards regarding flammability.

Fire models 4 and 5 would ignite explosively and flames would occasionally be extinguished by the explosion. Thus, it was difficult to tell if the fire was burning at all and, if so, the time at which it was extinguished. Thus, in consultation with the USCG Contract Technical Representative the following changes were made:

- (1) The end of the engine compartment was removed on Fire Model 4 to improve combustion stability and also to allow the operator to visually determine when the fire had been extinguished.
- (2) For Fire Model 5 (powered ventilation) the wooden pallet was replaced by metal grating and a thermocouple was installed to indicate when extinguishment had occurred.

Changes to other fire models were also made as follows:

- (1) Fire Model 1; the preburn time was increased from 5 to 15 seconds in order to allow time for the fire to fully develop.
- (2) Fire Model 3; the amount of shredded paper was reduced from 5"-6" to 2"-3".
- (3) Fire Model 6; the preburn time was reduced from 60 seconds to 30 seconds to reduce the amount of degradation in the fiber-glass lining material.

A test of each of the eleven extinguishers on the seven fires, defined as a series, was repeated four times with Heptane, once with gasoline, and once with diesel. This was done to provide sufficient data for a statistically significant analysis of the results. Testing of the extinguishers was done in a random order to minimize any bias which might be introduced by testing in a standard, fixed sequence.

The extent of the data recorded during a test is shown in a typical sheet, Figure 3-8. Extinguisher temperatures were assumed to be the same as ambient temperatures. Wind velocities were measured with an anemometer mounted approximately four feet above ground level. Testing was discontinued at wind speeds above 10 mph in order to standardize test conditions.

Two fire extinguisher operators were used in this program. Both began the program as unskilled operators, however, their skill levels increased as they became familiar with the operation of the extinguishers and the burning characteristics of the various fires. By the end of the first series with heptane as a fuel, they were considered well trained in fighting the particular fires used here.

Extinguisher performance was rated on a basis of six scores ranging from +3 to -3. The plus scores were assigned to cases of successful extinguishment, with the highest number for easiest accomplishment. The minus numbers were assigned to failures with -3 representing the case of least effectiveness.

Type 4 feet x 4 feet fuel spill on dry concrete
Test Apparatus: Shown in Photograph
Fuel: 2-1/2 quarts in recessed area
Preburn Time: 15 seconds
Attack: Begin application at windward edge of fire

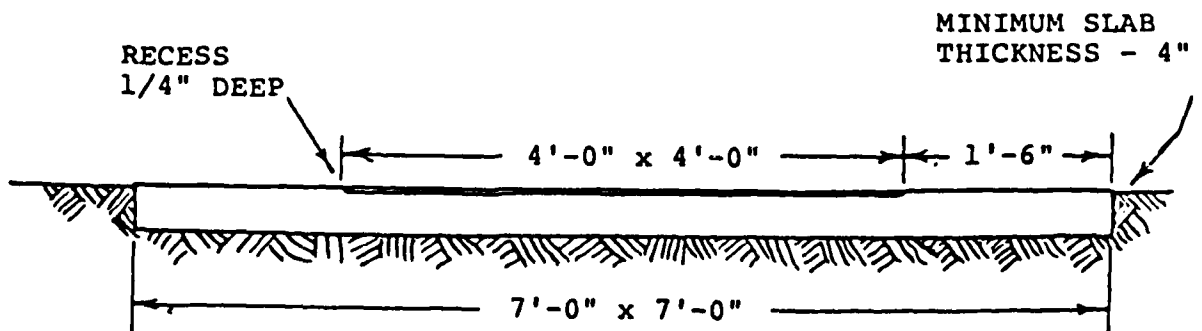
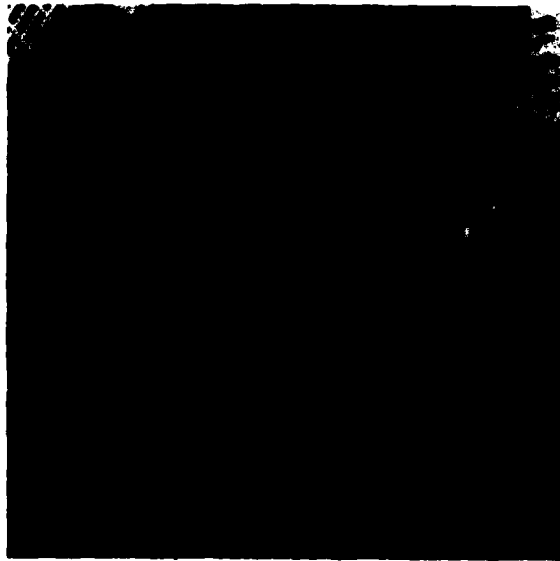

Figure 3-1. Fire Model 1 (Open Spill).

Type: Bilge

Test Apparatus: Shown in photograph. One inch of water in pan.

Fuel: 1 gallon on water in pan, and wood grating C (3 long, 4 short)

Preburn Time: 60 seconds

Wind Direction: Toward long edge

Attack: Begin application at center of windward long edge.

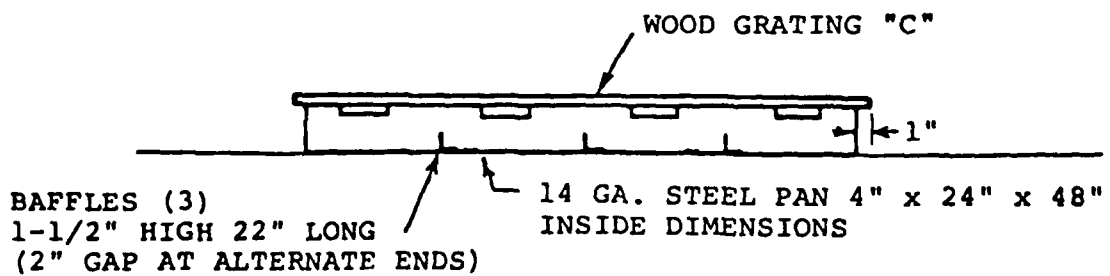
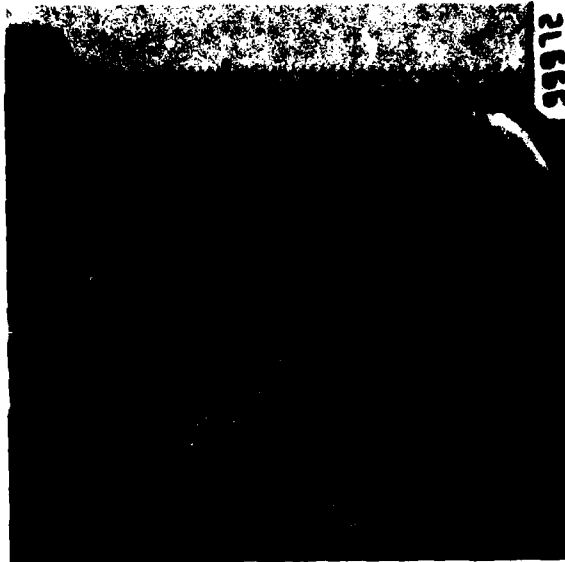

Figure 3-2. Fire Model 2 (Bilge).

Type: Fuel-saturated shredded paper - 2 feet x 4 feet area

Test Apparatus: Shredded paper as shown in photograph

Fuel: 2 quarts sprinkled over shredded paper

Preburn Time: 10 seconds

Wind Direction: Toward long edge

Attack: Begin application at center of windward long edge

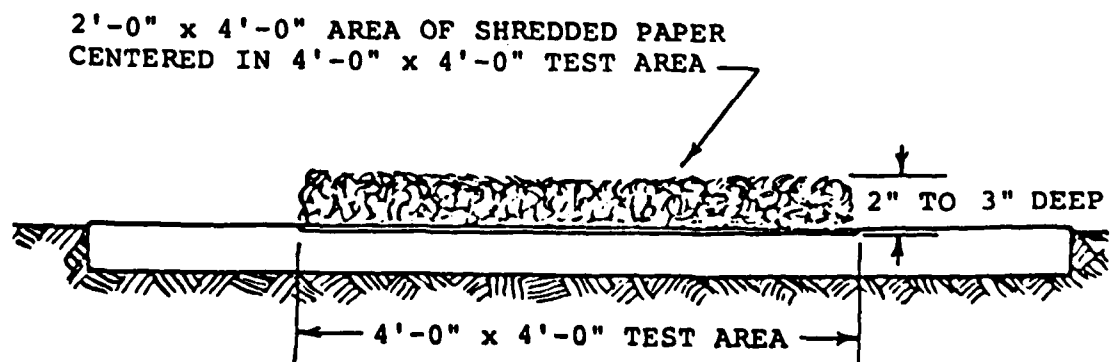

Figure 3-3. Fire Model 3 (Fuel Saturated Paper).

Type: Engine Compartment, open ended

Test Apparatus: As shown in photograph; 1 inch of water in pan

Fuel: 1 gallon on water and wood grating "A" (4 long, 4 short)

Preburn Time: 60 seconds

Attack: Through side hole



6" DIAMETER CIRCULAR
SIDE HOLE

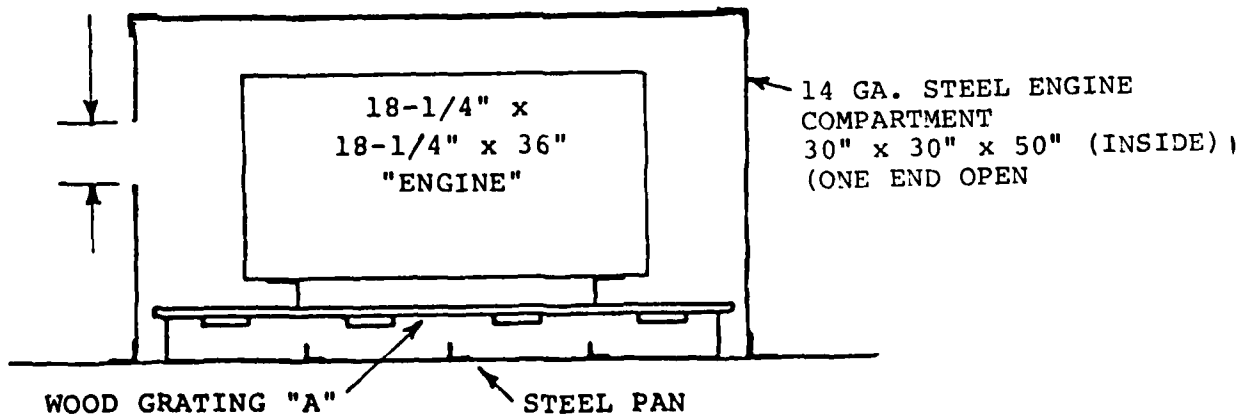

Figure 3-4. Fire Model 4 (Open Ended Engine Compartment).

Type: Engine Compartment, power ventilated

Test Apparatus: As shown in photograph; 1 inch of water in pan

Fuel: 1 gallon on water and steel grating

Preburn Time: 60 seconds

Attack: Through side hole

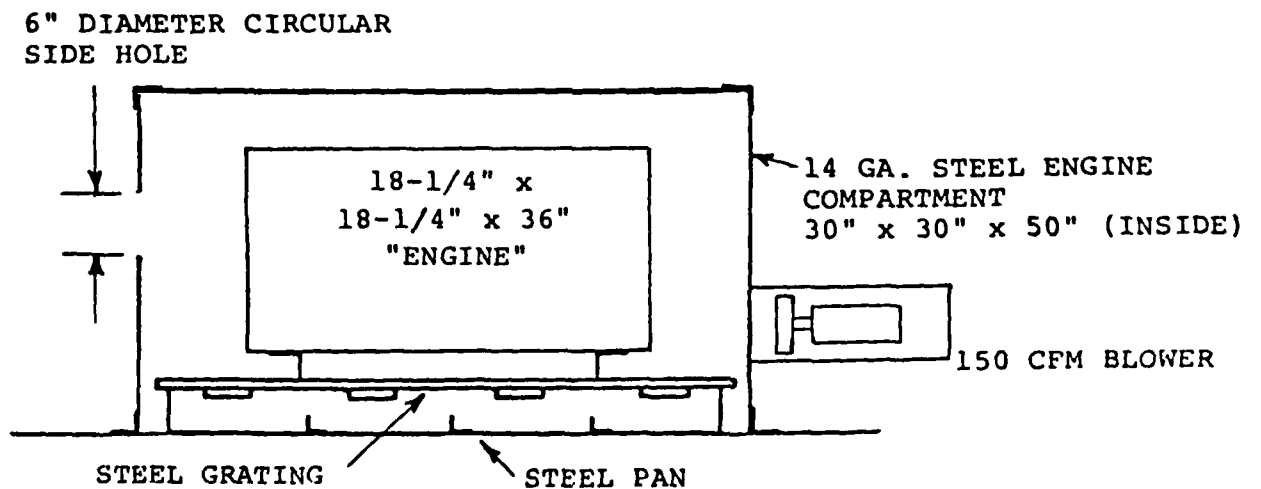
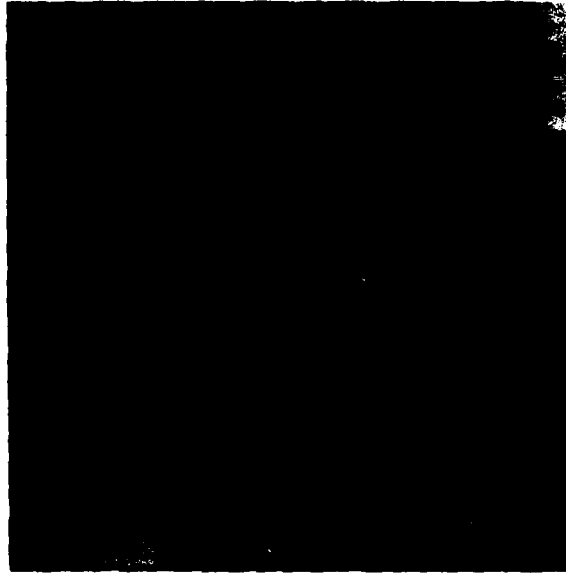

Figure 3-5. Fire Model 5 (Power Ventilated Engine Compartment).

Type: Open top engine compartment lined with fiber glass hull material (5 layers resin bonded glass cloth)

Test Apparatus: As shown in photograph; 1 inch of water in pan

Fuel: 1 gallon on water and wood grating A (4 long, 4 short)

Preburn Time: 30 seconds

Attack: Through open top at operator's discretion

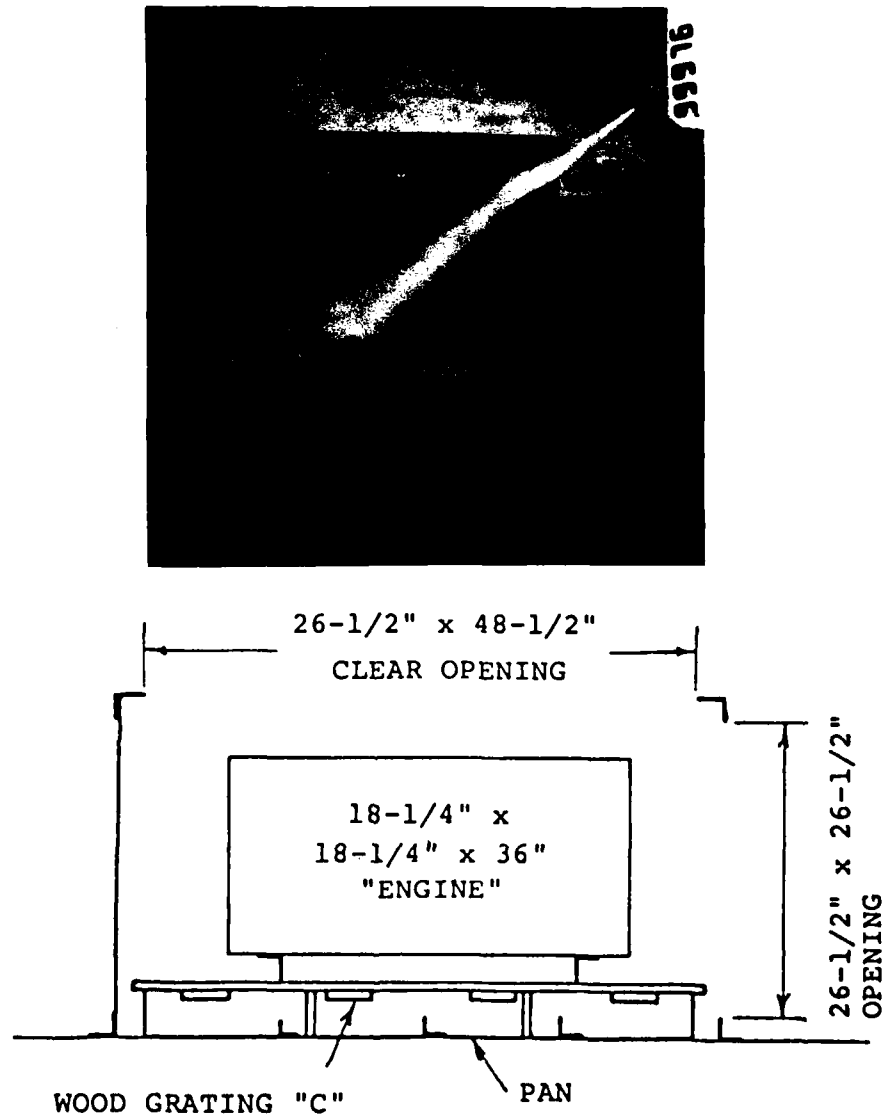

Figure 3-6. Fire Model 6 (Open-top, Fiberglass Lined Engine Compartment).

Type: Engine compartment, top and one end open

Test Apparatus: Shown in photograph; 1 inch of water in pan

Fuel: 1 gallon on water, and wood grating C (3 long, 4 short)

Preburn Time: 60 seconds

Wind Direction: Open end

Attack: Discharge agent into open end, follow through and aim into top of compartment

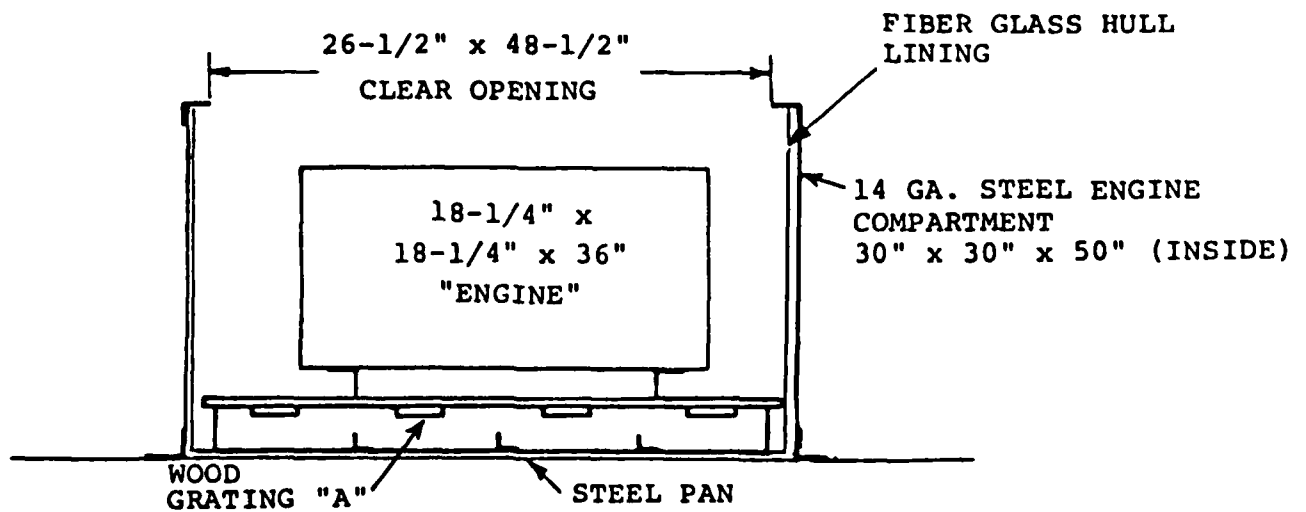

Figure 3-7. Fire Model 7 (Open-top and End Engine Compartment).

Fire No. _____ Date _____ Time _____
Extinguisher No. _____ Extinguisher Size _____
Manufacturer _____ Type of Charge _____ Gas _____
Extinguisher Total Weight _____ Charge Weight _____
Charge Pressure _____

WEATHER:

Sunny - Cloudy - Overcast -
Rain (in./hr.)

Atmospheric Temperature _____

Wind Direction
(to apparatus) _____

Wind Velocity mph _____

Humidity _____

Wet Bulb _____

TEST RESULTS:

Fuel _____

Delay to Extinguishment _____

Time Extinguisher Used _____

Method of Attack _____

Final Weight _____

Initial Operator Distance _____

Final Operator Distance _____

Agent Expended _____

Operator _____ Recorder _____

Wood Initial Weight _____

Wood Final Weight _____

Rating: -3, -2, -1; +1, +2, +3

REMARKS:

Units: lb, sec, °F, psi, cal, g.

Figure 3-8. Data Sheet - Motorboat Fire Test Data.

4.0 DISCUSSION OF FUELS

As stated earlier, three fuels were used in this study: heptane (4 series), gasoline (1 series) and diesel (1 series).

A commercial mixture of heptanes stated to be available indefinitely was used. This fuel, having a narrow distillation range at approximately 200° F, while forming a constituent of gasolines, was used in order to create reproducible conditions of fuel consumption throughout the test program as well as to provide fair burning equilibrium throughout the course of a single trial. Heptane was supplied under the brand name Skellysolve-C by Getty Refining Company, Tulsa, Oklahoma.

The properties of gasoline fluctuate seasonally, and vary with the producer and point of origin. Gasoline also, because of its wide volatile range, exhibits marked differences in characteristics during the burning of a specimen, with early consumption of the more volatile portions and ending in progressively slower burning of heavy fractions. The gasoline was one lot of 100 gallons supplied by Shell Oil Company with an octane rating of 88 and a Reid vapor pressure of 8.5 psig. It contained tetraethyl lead.

The diesel fuel was a No. 2-D grade. Some comparative properties of the three fuels are shown in Table 4-1.

	<u>Heptane</u>	<u>Gasoline</u>	<u>Diesel</u>
Flash Point °F	25	0	125
Reid Vapor Pressure (@100° F)	2.1	8.5	-
Theoretical Air/Fuel Ratio by Weight	15.14	14.97	15.06
Weight per gallon (lb)	6.01	6.16	7.67
Distillation 10%, °F	197	158	-
90%, °F	204	392	540-576

5.0 RESULTS

The performance ratings for the eleven extinguishers on the seven fire models are shown in Tables 5-1 (sum of four series with heptane), 5-2 (gasoline), and 5-3 (diesel). Only one series was run with gasoline and one with diesel. The plus ratings were based on the amount of available agent used to secure extinguishment, with an expenditure of one-third or less of the charge meriting the +3 rating, up to two-thirds rating +2, and a +1 rating going to those extinguishers nearly exhausted in the process. In cases of failure, the extinguisher charge was completely spent. Minus ratings, ranging from -1, almost extinguished, to -3, no apparent attenuation, were assigned on the basis of the operator's and observer's judgment.

The sum of the scores obtained in the heptane fires was used to compile the following ranking of the fire extinguishers with the best performing extinguisher ranked as No. 1.

<u>Ranking</u>	<u>Score</u>	<u>*U.L. Rating</u>	<u>Extinguisher No.</u>	<u>Agent</u>
1	68	60-B : C	6	6 lb Potassium Bicarbonate
2	63	10-B : C	2	5 lb Sodium Bicarbonate
3	48	10-B : C	9	5 lb Halon 1211
4	46	10-B : C	4	4.25 lb Ammonium Phosphate
5	46	20-B : C	11	2.5 gal AFFF
6	44	10-B : C	5	2.5 lb Potassium Bicarbonate
7	43	10-B : C	1	2.5 lb Sodium Bicarbonate
8	31	5-B : C	8	2.5 lb Halon 1211
9	25	10-B : C	3	2.5 lb Ammonium Phosphate
10	6	2-B : C	10	2.5 lb Halon 1301
11	-20	5-B : C	7	5 lb CO ₂

*The Coast Guard rating for all these extinguishers (except for No. 10 and 11 which are not rated) is Type B : C, Size I. No. 4 is also rated Type A, Size II.

The two top performing extinguishers are the larger sized sodium and potassium bicarbonate.

The four poorest performers are the 2.5 lb Halon 1211 and 2.5 lb Ammonium Phosphate plus the 2.5 lb Halon 1301 and 5 lb CO₂. The remaining fire extinguishers were approximately equal in performance.

The Halon 1301 and CO₂ extinguishers performed poorly in most fires. This appears to be due to the lower range or reach of these vapor type extinguishers. Thus, with the operators approaching the fire as closely as safety permitted, the energy of the discharge was not great enough to allow the agent to penetrate effectively into the flame zone.

Results of the single series performed with gasoline follow essentially the same pattern. Results with diesel differ somewhat but not significantly. It should be noted that Fire Models 1, 4, and 5 were deleted in the diesel series because the fuel would not stay burning. A few ounces of gasoline was added to the diesel to secure ignition but the fire would go out as soon as the gasoline was consumed.

TABLE 5-1. HEPTANE FUEL SUM OF SCORES OBTAINED BY THE 11
EXTINGUISHERS ON EACH OF THE 7 FIRE MODELS
(SUM OF FOUR RUNS)

Extinguisher Number	Type	Charge Weight	Fire Model Number							Total
			1	2	3	4	5	6	7	
1	Sodium Bicarb	2.5 lb	10	2	-4	12	7	12	4	43
2	Sodium Bicarb	5.0 lb	12	11	1	9	12	8	10	63
3	Ammonium Phosphate	2.5 lb	9	-6	-1	9	-2	12	4	25
4	Ammonium Phosphate	4.25 lb	11	5	-2	9	5	7	11	46
5	Purple K	2.5 lb	9	5	-1	2	12	12	5	44
6	Purple K	6.0 lb	12	8	8	12	10	10	8	68
7	CO ₂	5.0 lb	-3	-11	-9	-5	1	5	2	-20
8	Halon 1211	2.5 lb	9	-3	-8	11	12	7	3	31
9	Halon 1211	5.0 lb	10	6	-4	11	11	11	3	48
10	Halon 1301	2.5 lb	-5	-11	-11	9	12	12	0	6
11	AFFF	2.5 gal	5	7	3	8	8	8	7	46
TOTAL			79	13	-28	87	88	104	57	

TABLE 5-2. GASOLINE FUEL SCORES OBTAINED BY THE 11 EXTINGUISHERS ON EACH OF THE 7 FIRE MODELS (ONE RUN)

Extinguisher Number	Type	Charge Weight	Fire Model Number							Total
			1	2	3	4	5	6	7	
1	Sodium Bicarb	2.5 lb	3	1	-1	3	2	-1	3	10
2	Sodium Bicarb	5.0 lb	3	2	-1	3	2	2	3	14
3	Ammonium Phosphate	2.5 lb	3	-2	-3	3	-3	2	-1	-1
4	Ammonium Phosphate	4.25 lb	3	1	3	3	2	-3	3	12
5	Purple K	2.5 lb	3	-1	-1	3	3	-2	3	8
6	Purple K	6.0 lb	3	3	-2	3	3	2	3	15
7	CO ₂	5.0 lb	2	1	-3	3	1	1	-3	2
8	Halon 1211	2.5 lb	2	1	-3	3	2	2	-3	4
9	Halon 1211	5.0 lb	3	1	-3	3	3	2	2	11
10	Halon 1301	2.5 lb	3	1	-3	3	2	-3	1	4
11	AFFF	2.5 gal	3	2	1	1	1	-2	2	8
TOTAL			31	10	-16	31	18	0	13	

TABLE 5-3. DIESEL FUEL SCORES OBTAINED BY THE 11 EXTINGUISHERS ON EACH OF THE 7 FIRE MODELS (ONE RUN)

Extinguisher Number	Type	Charge Weight	Fire Model Number							Total
			1	2	3	4	5	6	7	
1	Sodium Bicarb	2.5 lb	D	3	-1	D	D	-1	3	4
2	Sodium Bicarb	5.0 lb	D	2	-2	D	D	1	3	4
3	Ammonium Phosphate	2.5 lb	D	-3	-3	D	D	2	2	-2
4	Ammonium Phosphate	4.25 lb	D	2	2	D	D	3	2	9
5	Purple K	2.5 lb	D	2	-1	D	D	-2	3	2
6	Purple K	6.0 lb	D	3	-1	D	D	3	2	7
7	CO ₂	5.0 lb	D	2	-2	D	D	3	-1	2
8	Halon 1211	2.5 lb	D	2	-2	D	D	3	-2	1
9	Halon 1211	5.0 lb	D	2	-2	D	D	-1	2	1
10	Halon 1301	2.5 lb	D	1	-1	D	D	-2	3	1
11	AFFF	2.5 gal	D	1	1	D	D	2	2	6
TOTAL			D	17	-12	D	D	11	19	

D = deleted because combustion could not be sustained

6.0 DISCUSSION OF RESULTS AND ANALYSIS

6.1 RANKING OF TEST FIRES

The fires are ranked in Table 6-1 in order of severity with the most difficult to put out assuming rank No. 1. The lower half of Table 6-1 compares the fire model severity ranking by fuels. There is general correlation in difficulty of extinguishment between fuels except that Fire Model 6 (Open top, fiber glass lined engine compartment) ranks 7 (easiest to extinguish) with heptane and it ranks 2 (second most difficult) with both gasoline and diesel. The reason for this discrepancy appears to be that toward the end of the test series, the fiber glass began sloughing away from the simulated engine compartment wall. This deterioration in the fire model made the fire more difficult to extinguish. Since gasoline and diesel were the final series in the program they were tested with a Fire Model 6 which differed in the foregoing regard from the condition it was in for the heptane tests.

Fire Model 1 (open spill) is shown as the easiest to put out and consequently an extinguisher which cannot put out this flame must receive a low rating. With heptane as a fuel, both the CO₂ and Halon 1301 failed to put this fire out on 3 out of 4 attempts.

Fire Model 3 (fuel-saturated shredded paper) is a different type of fire than the remaining six by virtue of the fact that the fire becomes deep seated in the paper waste and extinguishment is therefore more difficult and reignition is more frequent. Fire Model 3 was difficult for most of the eleven extinguishers to positively extinguish. Smoldering and reignition frequently occurred within five minutes.

In Fire Model 6 (open top compartment with resin bonded glass cloth) the preburn time was reduced from 60 to 30 seconds in the second and subsequent series in order to prolong the life of the fiber-glass layer. Also, after each fire, the exterior of the engine compartment was water cooled. Lowering the compartment wall temperature served to preserve the adhesion of the fiber glass cloth layers to the metal and prolong the usefulness of the fire model.

In Fire Models 4 (open-ended engine compartment) and 5 (engine compartment with powered ventilation) the vapors of the CO₂ and the Halon agents were confined making these extinguishers more effective here than in the open fires. AFFF was not effective in Fire Models 4 and 5 because the material must flow over the burning fuel to suffocate the flames. The flow of the agent was impeded by the baffles of this model.

TABLE 6-1. FIRE MODEL RANKING

Fire Model	Fire Type	Percent of Times Extinguished	Rank by Percent of Times Extinguished	Average Scores	Rank by Scores Attained by Extinguishers
3	Fuel-saturated Paper	29	1 (most difficult)	-0.64	1
7	Open-top, Open-end Engine Compartment	64	2	1.30	3
2	Bilge	68	3	.30	2
4	Open-end Engine Compartment	82	4	1.98	5
6	Open-top, Fiber Glass Lined Engine Compartment	83	5	2.36	7
5	Power-ventilated Engine Compartment	85	6	2.00	6
1	Open Spill	89	7	1.80	4

COMPARATIVE RANKING (BY DIFFICULTY OF EXTINGUISHMENT) OF FIRES WITH DIFFERENT FUELS.

Fire Model No.	Heptane		Gasoline		Diesel	
	Rank	Average Score	Rank	Average Score	Rank	Average Score
3	1	-0.64	1	-1.45	1	-1.09
2	2	0.30	3	0.91	3	1.55
7	3	1.30	4	1.18	4	1.73
1	4	1.80	6	2.82	-	-
4	5	1.98	7	2.82		
5	6	2.00	5	1.64		
6	7	2.36	2	0	2	1.00

6.2 GENERAL OBSERVATIONS

- (1) For each of the powder agents, the larger size was most effective in extinguishing the flames. This was most noticeable in open fires, e.g. Fire models 1, 2, and 3. The 5- or 6-pound extinguishers have a higher discharge rate and provided some reserve capacity. After complete discharge of a 2.5-pound charge, a flare-back or reignition was frequent. A 5- to 6-pound charge weight was, however, adequate to extinguish the flames and prevent reignition. A problem with the larger extinguishers was encountered on Fire Model 3 in that the greater discharge velocities of these extinguishers acted to blow the burning paper shreds around the test area creating additional fire hazards.
- (2) Both the 5 lb CO₂ and 2.5 lb Halon 1301 (Nos. 7 and 10) were reasonably effective on confined fires but were ineffective on open fires.
- (3) The 2.5 lb Ammonium Phosphate and 2.5 lb Halon 1211 were marginally effective in comparison with the larger size powder extinguishers.
- (4) The 5 lb Halon 1211 compares favorable with the powders in all fire models.
- (5) Gasoline was second to last in series testing. Operators were more skilled by this time, but failures or non-extinguishments occurred with the same frequency as with the heptane series.

6.3 INFLUENCE OF AMBIENT CONDITIONS ON THE RESULTS

The fire test program was conducted outdoors during August and September under ambient conditions of the following limits: wind velocity from 0 to 10 mph, temperature 78° F to 111° F, relative humidity 15 to 53 percent. Under this range of ambient conditions there was little difference in burning characteristics. Diesel ignition proved to be easier as the temperature increased.

7.0 CONCLUSIONS AND RECOMMENDATIONS

Table 7-1 shows recommended modifications to Table 25.30-10 (c) of 46 CFR. The rationale used in developing this table is discussed in the following paragraphs.

The existing Table 25.30-10 (c) shows a 2 pound dry chemical extinguisher as a Size I extinguisher. The smallest dry chemical extinguisher used in this program was 2.5 pounds, a readily obtainable size. This extinguisher was therefore selected as a standard for Size I extinguishers. To fill out the Size I category with other extinguishing agents, it then became a matter of looking at the data to determine the quantity of agents needed to give extinguishing capability equivalent to that of the 2.5 pound extinguisher.

The scores shown in Section 5.0 were used for this evaluation and show that the 2.5 gallon AFFF and 5 pound Halon 1211 have approximately the same scores as the 2.5 pound sodium and potassium bicarbonate extinguishers. These units were therefore also placed in the Size I category. The 5 pound CO₂ extinguisher was inferior in extinguishing capability to the 2.5 pound dry chemical and therefore, based on judgement, the size of this unit was increased by 50% to meet the postulated capability for a Size I extinguisher. This completes the Size I extinguisher roster.

Size II and Size III extinguishers were selected somewhat more arbitrarily since no extinguishers in this category were tested. The dry chemical extinguishers were again used as a standard and larger sizes approximating the estimated extinguishing potential in the current Table 25.30-10 (c) were selected. After selecting the dry chemical extinguishers it became a matter of establishing

suitable sizes for other agents to obtain the same approximate extinguishing capacity. This was done based primarily on experience and judgment gained in performing the test work in this program and guided somewhat by the UL ratings on typical extinguishers of the types shown. The selected sizes for each agent are shown in Table 7-1.

TABLE 7-1. PROPOSED MODIFICATIONS TO TABLE 25.30-10 (C)

<u>Classification Type</u>	<u>Size</u>	<u>Foam Gallons</u>	<u>Carbon Dioxide Pounds</u>	<u>Dry Chemical Pounds</u>	<u>Halon 1211 Pounds</u>
B	I	2.5	7.5	2.5	5
B	II	5.0	20.0	7.5	15
B	III	12.0	40.0	15.0	30

In summary, then, the recommended changes to Table 25.30-10 (c) as shown in Table 7-1 for Size I extinguishers were based on data collected in this program. Changes in the Size II and III extinguishers were selected on a more arbitrary basis using experience and judgment gained in conducting this test effort.

After some study of Table 25.30-20 (a) (which specifies the minimum number of hand portable extinguishers required for various types of boats), it was determined that no obvious reason for changing this table came to light and therefore it is recommended that this table remain unchanged.

**DAT
ILMI**