

UNCLASSIFIED

SECURITY CLASSIFICATION OF THIS PAGE (When Data Entered)

3890

AD A108138

REPORT DOCUMENTATION PAGE		READ INSTRUCTIONS BEFORE COMPLETING FORM
1. REPORT NUMBER TOP 6-2-521	2. GOVT ACCESSION NO. A108138 ✓	3. RECIPIENT'S CATALOG NUMBER
4. TITLE (and Subtitle) US ARMY TEST AND EVALUATION COMMAND TEST OPERATIONS PROCEDURE ENGINEERING INTELLIGIBILITY TESTING OF VOICE COMMUNICATION EQUIPMENT		5. TYPE OF REPORT & PERIOD COVERED Final
		6. PERFORMING ORG. REPORT NUMBER
7. AUTHOR(s)		8. CONTRACT OR GRANT NUMBER(s)
9. PERFORMING ORGANIZATION NAME AND ADDRESS US ARMY ELECTRONIC PROVING GROUND (STEEP-MT-DS) FORT HUACHUCA, ARIZONA 85613		10. PROGRAM ELEMENT, PROJECT, TASK AREA & WORK UNIT NUMBERS DARCOM-R 310-6
11. CONTROLLING OFFICE NAME AND ADDRESS US ARMY TEST AND EVALUATION COMMAND (DRSTE-AD-M) ABERDEEN PROVING GROUND, MARYLAND 21005		12. REPORT DATE 19 November 1981
		13. NUMBER OF PAGES 14
14. MONITORING AGENCY NAME & ADDRESS (if different from Controlling Office)		15. SECURITY CLASS. (of this report) Unclassified
		15a. DECLASSIFICATION/DOWNGRADING SCHEDULE
16. DISTRIBUTION STATEMENT (of this Report) Approved for public release; distribution unlimited.		
17. DISTRIBUTION STATEMENT (of the abstract entered in Block 20, if different from Report)		
18. SUPPLEMENTARY NOTES Best Available Copy 20040112187		
19. KEY WORDS (Continue on reverse side if necessary and identify by block number) Engineering Test Intelligibility (Voice) Voice Communications Equipment Test Procedures Test Methods		
20. ABSTRACT (Continue on reverse side if necessary and identify by block number) This engineering test procedure describes engineering test methods for evaluating the intelligibility of voice communication equipment. It addresses two types of testing, phonetically balanced word list testing and automatic testing by means of the Voice Intelligibility Analysis System.		

DISCLAIMER NOTICE

THIS DOCUMENT IS BEST QUALITY PRACTICABLE. THE COPY FURNISHED TO DTIC CONTAINED A SIGNIFICANT NUMBER OF PAGES WHICH DO NOT REPRODUCE LEGIBLY.

US ARMY TEST AND EVALUATION COMMAND
TEST OPERATIONS PROCEDURE

DRSTE-RP-702-105
*Test Operations Procedure 6-2-521
AD No. A108138

19 November 1981

ENGINEERING INTELLIGIBILITY TESTING OF VOICE COMMUNICATION EQUIPMENT

	<u>Page</u>
Paragraph 1. SCOPE.....	1
2. FACILITIES AND INSTRUMENTATION.....	2
3. PREPARATION FOR TEST.....	2
4. TEST CONTROLS.....	3
5. TEST CONDUCT.....	4
6. DATA REDUCTION AND PRESENTATION.....	5
APPENDIX A. DESCRIPTION OF THE VOICE SCORING FACILITY.....	A-1
APPENDIX B. DESCRIPTION OF THE VOICE INTELLIGIBILITY SCORING FACILITY.	B-1
APPENDIX C. SUBJECTIVE VOICE TRANSMISSION QUALITY TEST.....	C-1

1. SCOPE

1.1 SUMMARY

a. The procedures outlined in this TOP provide general guidance for determining the intelligibility characteristics of voice communication equipment. The cumulative test results will allow an estimate to be made of the effectiveness of the test item performance in the environment of intended use.

b. The Specific tests to be performed, along with their intended objectives, are as follows:

(1) Harvard Phonetically Balanced (PB) Word List Testing - The objective of this subtest is to obtain a percentage numerical score, referred to as articulation score (AS), for the test communications link effectiveness.

(2) Automatic Voice Intelligibility Analysis System (VIAS) Testing - The objective of this subtest is to obtain a numerical score of the test communications link effectiveness, referred to as the articulation index (AI). The use of this automated equipment provides high speed, low cost data analysis to meet the needs of test requirements.

(3) Appendix C provides a separate nonengineering Subjective Voice Transmission Quality Test procedure. The procedure is based on rating elements from ITU Radio Regulations, Geneva, 1959, but other authoritative rating elements can be used, i.e., Communications Instructions Radiotelephone Procedure, ACP 125(D) with changes 1 and 2, July 1970.

(4) The diagnostic rhyme test (DRT) and other word lists do not exercise the full spectrum phonemes as does the Harvard Phonetically Balanced Word List. This TOP uses only the above listed specific tests.

*This TOP supersedes MTP 6-2-521, 6 August 1970.

Approved for public release: distribution unlimited.

1.2 LIMITATIONS

a. The AS is a standard measure of intelligibility based on PB word lists. This method produces a good comparative measure but does not have a simple translation function for determining acceptability for different field applications, which are affected by such factors as message content and structure, user experience, and familiarity with material, as well as the purpose and circumstances of communication.

b. The AS does not allow a detailed analysis of where intelligibility loss occurs such as that which may be provided by the diagnostic rhyme test (DRT) or other phoneme discrimination or confusion measurements.

c. While providing a fast and economical measure of intelligibility, the VIAS has a limited capability to evaluate the effects of speech processing. It must be validated and calibrated relative to a more complete measure such as AS before being used to predict performance of systems employing new modulation or voice coding techniques.

d. The engineering test (body of this TOP) and the subjective test (app C) are separate and distinct test procedures and are not intended to comply, refute, or conflict with other methods; i.e., HFE TOP 1-2-610, the linear predictive coding technique (LPC) or other authoritative sources.

2. FACILITIES AND INSTRUMENTATION

- a. Voice Scoring Facility.
- b. Voice Intelligibility Analysis System (VIAS).
- c. Test apparatus, as required for operational tests of the test item.
- d. Support equipment, as required to operate test item.

3. PREPARATION FOR TESTING

Upon establishing the scheduled availability of the test item, the test officer and engineer shall ensure availability of appropriate facilities and coordinate the availability of test support requirements. This support will include personnel, equipment, maintenance, spare parts, and instrumentation. Special attention shall be given to timely provision of additional supplies or equipment not readily available to the test site.

3.1. Preparation for Test

Data to be recorded prior to testing shall include, but not be limited to:

- a. Nomenclature, serial number(s), manufacturer's name, and function of the item(s) under test.

b. Nomenclature, serial number, accuracy tolerance, calibration requirements, and last calibration date of test equipment selected for the tests.

c. Damages to the test item(s) incurred during transit and/or manufacturing defects.

4. TEST CONTROLS

4.1 Test Item

a. Record the following information: nomenclature, serial number(s), manufacturer's name, and function of the item(s) under test.

b. Ensure that all test personnel are familiar with the required technical and operational characteristics of the item under test.

c. Review all instructional material issued with the test item by the manufacturer, contractor, or government, as well as reports of previous similar tests conducted on the same types of equipment. Keep these documents readily available for reference.

d. Prepare record forms for systematic entry of data including the pre-test equipment record, chronology of test, test results, and such observations and measurements that would be of value in analysis and final evaluation.

e. Prepare adequate safety precautions to provide safety for personnel and equipment. Ensure that all safety standing operating procedures are observed throughout the test.

4.2 Test Equipment

a. Select test equipment that is in keeping with the state-of-the-art and with calibration traceable to the National Bureau of Standards.

b. Record the following information: nomenclature, serial number, accuracy tolerances, calibration requirements, and last calibration date of test equipment selected for the test.

c. Check the magnetic tape equipment for operational readiness and make all adjustments required by the operational manuals.

d. Load the master tapes on the tape playback equipment and check for proper operation.

e. Calibrate the VIAS equipment in the manner prescribed in the operational and technical manuals.

5. TEST CONDUCT

5.1 PB Word List Testing

a. Set up the voice communication system or equipment in one of the two basic testing configurations, closed-link or open-field. All testing configurations should have two high-fidelity magnetic tape recorders -- a playback recorder at the transmitting site and a receiver recorder at the receiving site.

b. Transmit a PB word list on the playback recorder through the communications test link to the receiver recorder at the receiving site.

c. Repeat the recording procedures under the conditions stated by the test plan. The exact conditions must be recorded so that follow-on tests can duplicate the same conditions to the maximum extent possible.

d. Score the PB word list test in the Voice Scoring facility (see app A).

5.2 Automatic Testing

a. Connect the test signal generator and VIAS to the test link as indicated in appendix B.

b. Transmit the 950-Hz pilot tone through the test link and record the clear-channel AI.

c. Repeat the procedures and record the AI scores under the conditions stated by the test plan.

5.3 Test Notes

Data to be recorded in addition to specific instructions listed in each subtest shall include:

a. A block diagram of the test setup employed in each specified test. The block diagram shall identify, by model and serial number, all test equipment and interconnections (cable lengths, connectors, attenuators, etc.) and indicate control and dial settings where necessary.

b. An engineering logbook containing, in chronological order, pertinent remarks and observations which would aid in a subsequent analysis of the test data.

c. A description of any special voice processing circuitry employed by the test item and an analysis of their effect on test results.

5.4 Test Data

The following data shall be recorded as required by the test plan:

- a. Sensitivity.
- b. Signal-to-interference ratio.
- c. Signal-to-noise ratio.
- d. Adjacent channel frequencies.
- e. Crew AS.
- f. Unbiased standard deviation of the AS values.
- g. Separate AS values for male versus female speakers.
- h. Frequently missed words.
- i. Individual listener scores for each speaker.
- j. Word lists employed.
- k. AI.

6. DATA REDUCTION AND PRESENTATION

Processing of raw test data shall, in general, consist of organizing, marking for correlation and identification, and grouping of the test data. Test item specifications shall be noted on the test data presentation to facilitate analysis and comparison. Comparisons can be made with scores obtained on other systems where identical tests were conducted. The data shall be reduced and presented in accordance with the test plan.

Recommended changes to this publication should be forwarded to Commander, US Army Test and Evaluation Command, ATTN: DRSTE-AD-M, Aberdeen Proving Ground, MD, 21005. Technical information may be obtained from the preparing activity: Commander, US Army Electronic Proving Ground, ATTN: STEEP-MT-T, Ft Huachuca, AZ 85613. Additional copies are available from the Defense Technical Information Center, Cameron Station, Alexandria, VA 22314. This document is identified by the accession number (AD No.) printed on the first page.

APPENDIX A

DESCRIPTION OF THE VOICE SCORING FACILITY

The Voice Scoring Facility consists of a specially constructed, acoustically insulated listener and equipment room, and the following instrumentation: high fidelity audio magnetic tape recorder/reproducers, high fidelity headsets, high fidelity microphone, a microprocessor control unit, cathode ray tube (CRT) display consoles with selector switches, and punched tape equipment.

The physical arrangement of the listener and equipment room is shown in figure A-1. Provisions are made for eight listener consoles and one test controller. The test controller may view and talk to the listeners and monitor sounds occurring in the listener room. A functional block diagram is shown in figure A-2.

Testing is conducted under a consistent and strict experimental design. In operation, tape recorded material to be scored is presented to the listeners, who register their responses by pressing the appropriate pushbutton on their respective display consoles. (Table A-1 shows samples of the PB word lists used in the test tapes.)

CRT screens are used to display the preselected word groupings to the listeners. The displays consist of key words used in test carrier phrases. These word groupings appear in a five line format with each line containing 10 words. Each word is positioned directly above a selector pushbutton switch. The listeners press the button under the key word (as they understand it) each time a test sentence is heard. A given display contains the words from two word lists to reduce the possibility of the listener using a process of elimination in masking devices. Also, the design of the instrumentation facilitates a force-choice mode of operation by holding up the next word until each listener has responded, even if only by guessing.

After the listener has pushed a switch to indicate his word choice, the selector buttons are disabled to prevent any change, and the control unit codes and retains the word choices. A new test sentence is presented to the listeners, and the cycle is repeated until all 50 words have been scored. Upon completion of the word list test, the control unit calculates AS and standard deviation and punches a paper tape which records all listener responses to each word within the list. This paper tape may be used for further reduction of the data as required.

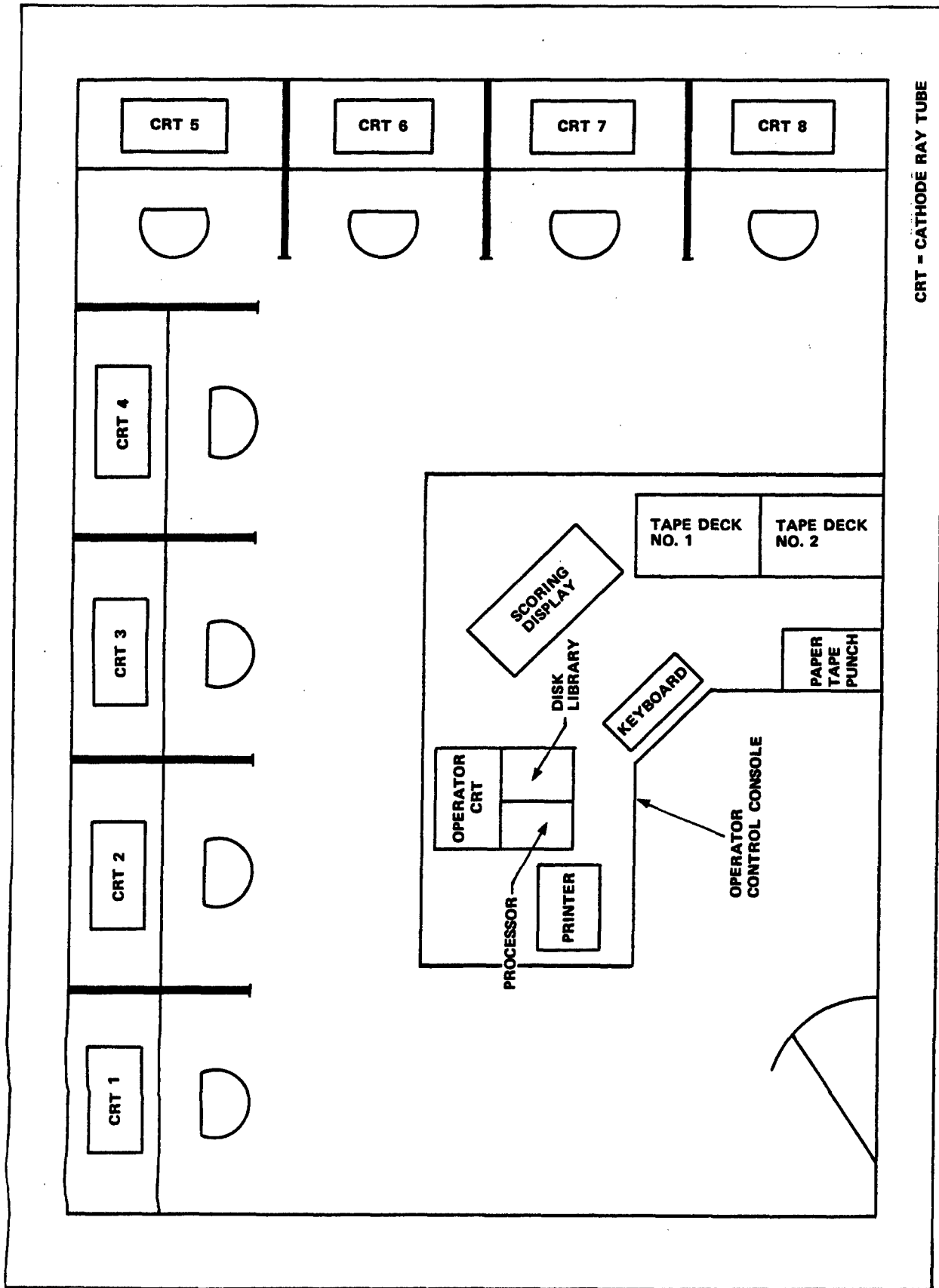

Figure A-1. Voice scoring facility layout.

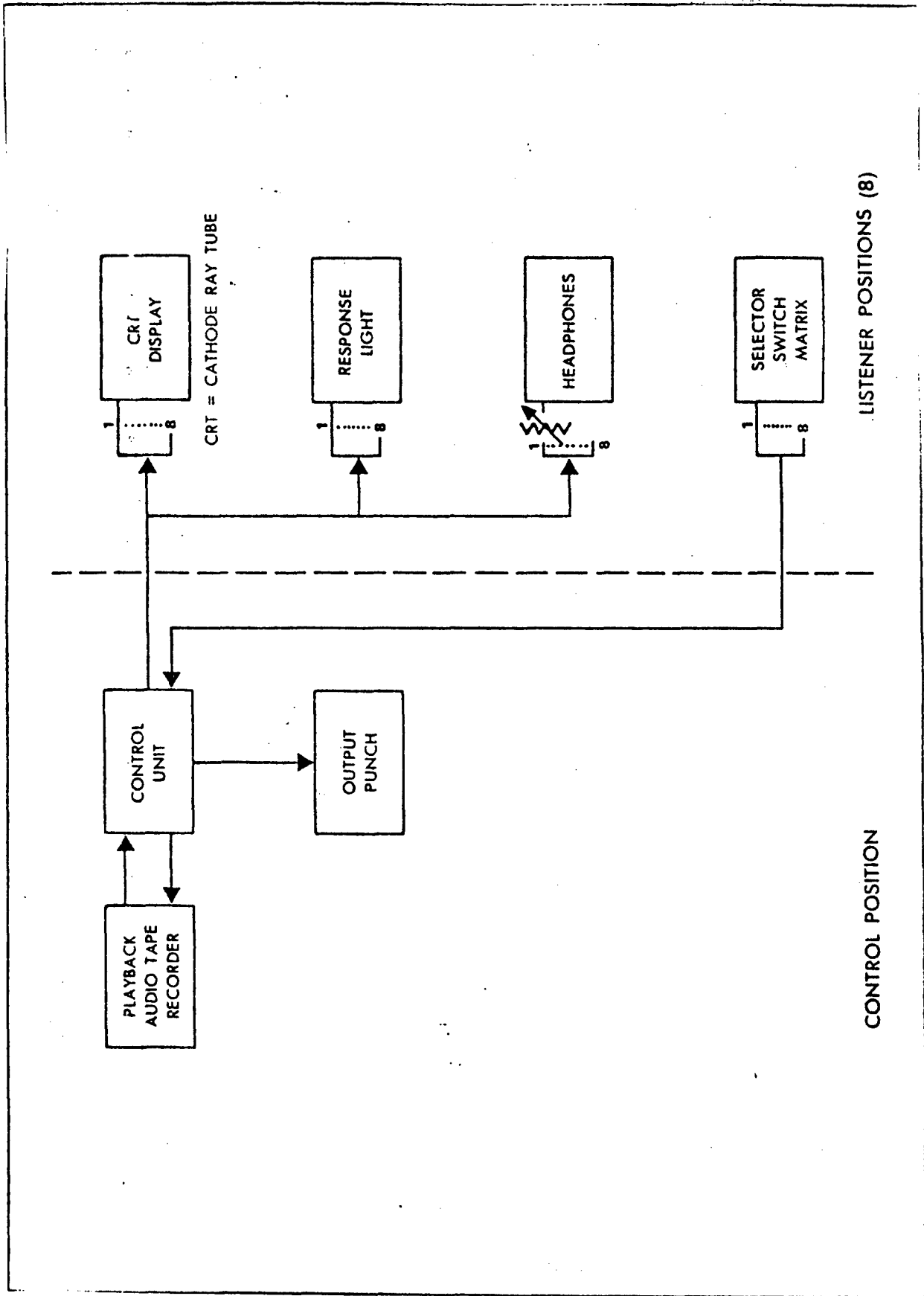

Figure A-2. Voice scoring facility functional diagram.

TABLE A-I. REPRESENTATIVE PHONETICALLY BALANCED (PB) WORD LISTS

PB-50 List 9		PB-50 List 10	
1. arch	26. with	1. goose	26. ail
2. year	27. noose	2. slug	27. youth
3. fluff	28. fume	3. rape	28. etch
4. phone	29. rude	4. nudge	29. put
5. crowd	30. hoof	5. page	30. cue
6. lit	31. foe	6. rip	31. line
7. gate	32. club	7. hat	32. force
8. pact	33. fuse	8. valve	33. plus
9. thank	34. mass	9. fir	34. tag
10. chest	35. sip	10. cow	35. clothe
11. weak	36. ten	11. flight	36. wake
12. throne	37. ditch	12. maze	37. cord
13. than	38. give	13. those	38. scrub
14. reed	39. spud	14. staff	39. void
15. birth	40. toad	15. rush	40. mope
16. itch	41. troop	16. snipe	41. champ
17. boost	42. beef	17. ears	42. lap
18. carve	43. cud	18. gull	43. flaunt
19. key	44. root	19. earth	44. pink
20. nuts	45. bit	20. bash	45. daub
21. odd	46. ice	21. jay	46. real
22. chess	47. grace	22. bug	47. bob
23. wipe	48. clown	23. thug	48. chance
24. flag	49. smart	24. tree	49. wade
25. wild	50. nerve	25. back	50. hurt

APPENDIX B

DESCRIPTION OF THE VOICE INTELLIGIBILITY ANALYSIS SYSTEM

The articulation index (AI) value of a voice communication link may be determined under field or laboratory conditions by the Voice Intelligibility Analysis System (VIAS). The VIAS equipment consists of voice analyzer sets, self-check signal generators, and test-signal generators, with their associated amplifiers and power supplies. The test-signal generator supplies a 950-Hz tone, which is used operationally as the modulation signal for the link under test. To account for the effect of speech clipping, which is employed on many military transmitters, the 950-Hz tone is modulated with a 5-Hz signal. The pilot tone, which has the same rms value as the long term value of English speech, is transmitted over the test link instead of speech. The voice analyzer set, or basic VIAS, performs the AI determination on the basis of received signal.

The VIAS accounts for amplitude distortion, intermittent noise, and upward spreading of masking. The AI depends on the property of speech intelligibility which allows the speech spectrum to be divided into several frequency bands, each band contributing equally to the intelligibility of the total speech.

In essence, the AI is determined by measuring the signal-to-noise ratio in each of the bands logarithmically and then summing over the bands. Smoothing is provided by integrating the summed results over a period of 17 seconds. Contribution switches for the individual bands are preset to ZERO, HALF, or FULL, to compensate for the predetermined audio pass band characteristics peculiar to each test item type or configuration. The concept of testing by means of the VIAS is depicted in figure B-1.

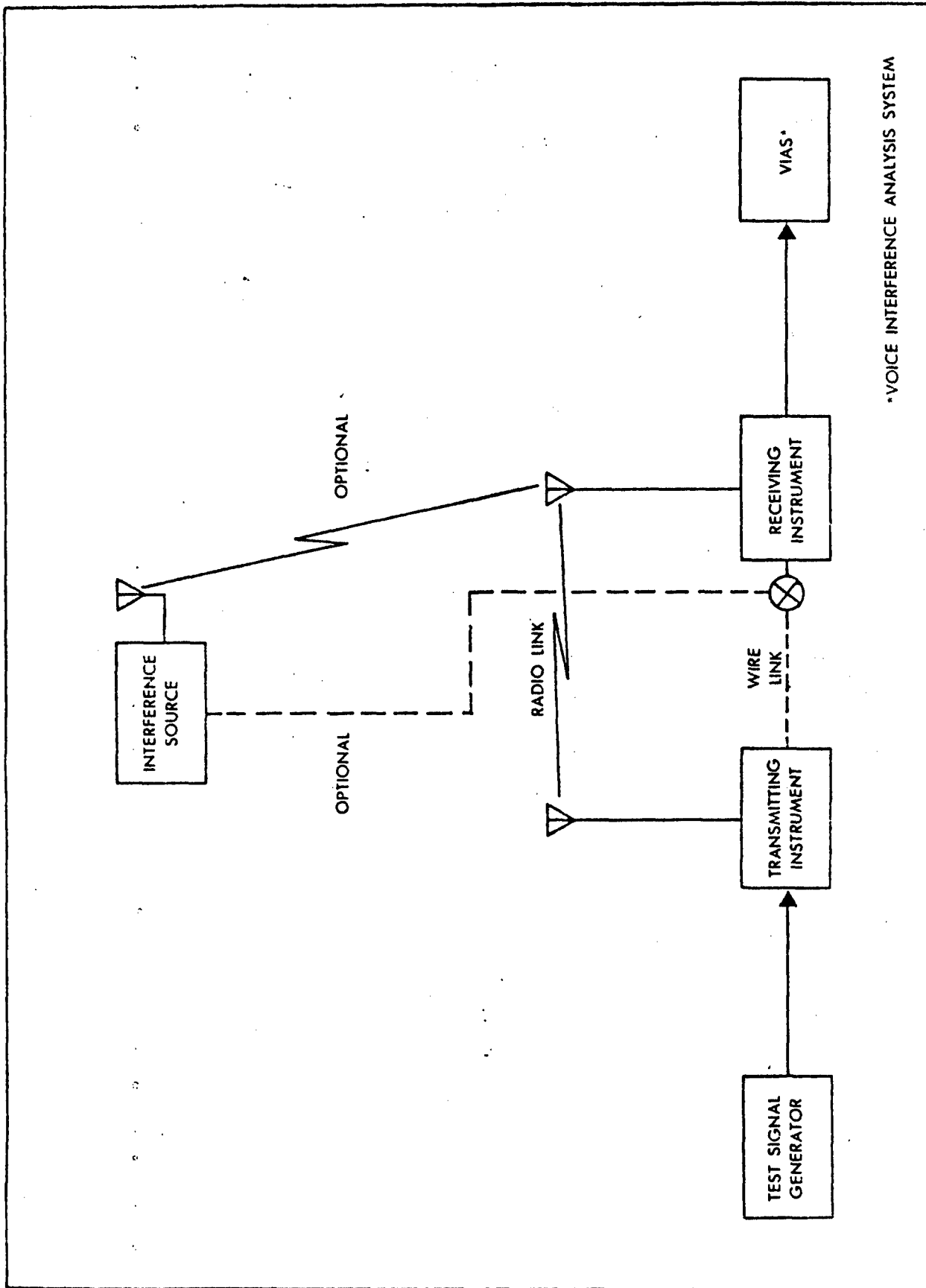

Figure B-1. The VIAS test link concept.

APPENDIX CSUBJECTIVE VOICE TRANSMISSION QUALITY TEST

1. SCOPE. This test procedure outlines a test method for use in performing subjective evaluations of voice transmission quality over voice communications equipment. It defines voice transmission quality in terms of the signal strength (volume), degrading effects of noise, and the overall quality of the voice channel under test. Each of these three elements is rated subjectively on a scale of 1 (one) to 5 (five) based on the definitions listed at the top of page C-3. The scope of this procedure is limited to test programs that do not require quantitative evaluations of voice performance. This procedure should not be used where the effectiveness (intelligibility) of the voice communications is a critical issue. The requirements should be identified in the Independent Evaluation Plan or other requirements documents.

2. FACILITIES AND INSTRUMENTATION. No special facilities or instrumentation are required other than what is required for the normal operation and maintenance of the test items. Refer to the instruction manuals.

3. PREPARATION FOR TESTS.

a. Screen test operators/collectors for hearing impairment. Conduct hearing tests by appropriate medical personnel if there is any question of hearing capabilities.

b. Brief participating test personnel on all aspects of the test program to include the purpose of the test and the requirements for precision during test conduct.

c. Provide sufficient copies of operating instructions/detailed test procedures to all participating test personnel.

d. Perform the operational checks, maintenance procedures, alignment, and calibration steps specified in pertinent instruction manuals to insure that the test item(s) is in proper operating condition. Prepare the test item(s) insofar as possible, to represent the equipment in normal operating condition.

4. TEST CONTROLS. Consider acoustical noise in the placement of the test item(s) and during the conduct of the test. Avoid high ambient noise sources, such as power generating equipment and aircraft, if they are not representative of the tactical operational environment.

5. PERFORMANCE TESTS.

a. Verify the placement and setup of the test item(s) and support equipment.

b. Power up the equipment and conduct appropriate performance checks as listed in the instruction manuals.

- c. Verify voice communications on the selected channel.
- d. Complete the data collection sheet. Describe fully in the remarks section of the data sheet any adverse conditions such as distortions, background noise, speech clarity, etc.
- e. Repeat steps c and d for the opposite direction of transmission.
- f. Repeat steps c through e for each of the selected test channels as indicated in the detailed test procedure.

6. DATA REDUCTION AND PRESENTATION. Review the data collection sheets and present the data in tabular form. Include other pertinent performance data in the tabular data.

DATA COLLECTION SHEET

1. Test Item(s): _____ 2. SN: _____

3. Test Sequence No.: _____ 4. Test Operator: _____

5. Date: _____ 6. Time: _____

7. Detailed Test Procedure Para No. (Step No.): _____

8. Channel ID (No.): _____

9. Calling Party ID (No.): _____

10. Called Party ID (No.): _____

11. Subjective Evaluation (Circle appropriate number)

11a. Signal Strength (volume)	11b. Noise Level	11c. Readability (Quality)
5 Excellent	5 Nil	5 Excellent
4 Good	4 Slight	4 Good
3 Fair	3 Moderate	3 Fair
2 Poor	2 Severe	2 Poor
1 Barely Audible	1 Extreme	1 Unusable

12. Remarks: (describe fully any adverse conditions):

DEFINITIONS OF RATING ELEMENTS*

<u>Rating Scale</u>	<u>Rating Element</u>	<u>Condition</u>
5	Excellent	Signal (voice) quality unaffected by the transmission media.
4	Good	Signal (voice) quality slightly affected.
3	Fair	Signal (voice) quality seriously affected. Channel usable by operators but not suitable for mission traffic.
2	Poor	Channel just usable by operators.
1	Unusable	Channel unusable by operators.

TEST OPERATIONS CHECKLIST

1. Test item(s) and support equipment in place and in proper operating condition _____
2. Operator personnel have been briefed on conduct of test _____
3. Operating instructions/detailed test procedures and data collection sheets have been provided to all test operators/data collectors _____
4. Perform test _____
5. Review test data _____
6. Retest, if required _____
7. Prepare test data in final reduced format _____

REFERENCES

1. "Reference Data for Radio Engineers", Howard W. Sams & Co., Inc., Fifth Edition, October 1968.
2. "Transmission Systems for Communications", Bell Telephone Laboratories, Inc., Revised Fourth Edition, December 1971.

*From ITU Radio Regulations, Geneva, 1959