

AD-A108 149 NAVAL AIR ENGINEERING CENTER LAKEHURST NJ SHIP INSTAL--ETC F/8 1/5
INVESTIGATION OF CROSSDECK PENDANT CATAPULT SLOT INTERACTION; P--ETC(U)
UNCLASSIFIED NOV 81 A HITTNER NL
NAEC-91-7964

1 of 1
0814

END
DATE
FILMED
DTIC

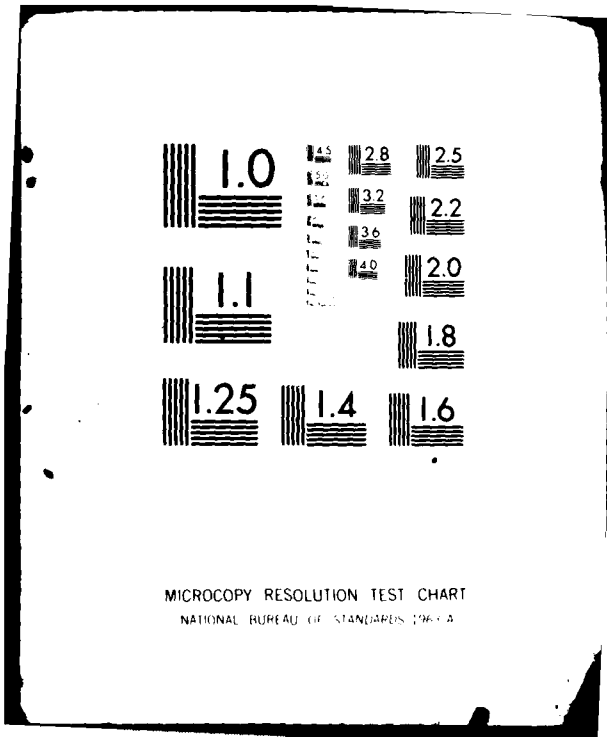

MICROCOPY RESOLUTION TEST CHART
NATIONAL BUREAU OF STANDARDS 1963-A

LEVEL II

(12)

fw



NAVAL AIR ENGINEERING CENTER

NAEC-91-7964

LAKEHURST, N.J.
08733

AD A108149

**INVESTIGATION OF CROSSDECK PENDANT
CATAPULT SLOT INTERACTION; PROPOSED
CORRECTIVE MEASURES FOR**

Launch and Recovery Division
Ship Installations Engineering Department
Naval Air Engineering Center
Lakehurst, New Jersey 08733

20 NOVEMBER 1981

Final Report for Period April 1978 through March 1979
AIRTASK A5515512/0514/0551000117

APPROVED FOR PUBLIC RELEASE:
DISTRIBUTION UNLIMITED

DTIC
ELECTE
DEC 8 1981

Prepared for

Commander
Naval Air Systems Command
Washington, DC 20361

A

81 12 08 027

DTIC FILE COPY

NAEC-91-7964

INVESTIGATION OF CROSSDECK PENDANT
CATAPULT SLOT INTERACTION; PROPOSED
CORRECTIVE MEASURES FOR

Prepared by: A. Hittner
A. Hittner

Approved by: [Signature]

NOTICE

Reproduction of this document in any form by other than naval activities is not authorized except by special approval of the Secretary of the Navy or the Chief of Naval Operations as appropriate.

The following espionage notice can be disregarded unless this document is plainly marked CONFIDENTIAL or SECRET.

This document contains information affecting the national defense of the United States within the meaning of the Espionage Laws, Title 18, U.S.C., Sections 793 and 794. The transmission or the revelation of its contents in any manner to an unauthorized person is prohibited by law.

11-20-81 10A

UNCLASSIFIED

SECURITY CLASSIFICATION OF THIS PAGE (When Data Entered)

REPORT DOCUMENTATION PAGE		READ INSTRUCTIONS BEFORE COMPLETING FORM
1. REPORT NUMBER NAEC-91-7964	2. GOVT ACCESSION NO. AD-108149	3. RECIPIENT'S CATALOG NUMBER
4. TITLE (and Subtitle) Investigation of Crossdeck Pendant Catapult Slot Interaction; Proposed Corrective Measures for	5. TYPE OF REPORT & PERIOD COVERED Final April 1978 to March 1979	
	6. PERFORMING ORG. REPORT NUMBER NAEC-91-7964	
7. AUTHOR(s) Alvin Hittner	8. CONTRACT OR GRANT NUMBER(s)	
9. PERFORMING ORGANIZATION NAME AND ADDRESS Commanding Officer, Naval Air Engineering Center (91) Lakehurst, NJ 08733	10. PROGRAM ELEMENT, PROJECT, TASK AREA & WORK UNIT NUMBERS	
11. CONTROLLING OFFICE NAME AND ADDRESS Commander, Naval Air Systems Command (AIR-551) Washington, DC 20361	12. REPORT DATE 20 November 1981	
	13. NUMBER OF PAGES 57	
14. MONITORING AGENCY NAME & ADDRESS (if different from Controlling Office)	15. SECURITY CLASS. (of this report) Unclassified	
	15a. DECLASSIFICATION/DOWNGRADING SCHEDULE	
16. DISTRIBUTION STATEMENT (of this Report) Approved for public release; distribution unlimited.		
17. DISTRIBUTION STATEMENT (of the abstract entered in Block 20, if different from Report)		
18. SUPPLEMENTARY NOTES Prepared under AIRTASK A5515512/0514/0551000117		
19. KEY WORDS (Continue on reverse side if necessary and identify by block number) Cable Damage Buttons Slot Filler Devices		
20. ABSTRACT (Continue on reverse side if necessary and identify by block number) This report documents the investigation of the crossdeck pendant failure aboard USS JOHN F. KENNEDY (CV 67) in March 1978, which caused the loss of an F-14A. Included are the results of a survey to determine the scope of the deck pendant/catapult slot interaction problem, testing to confirm the failure sequence, and the evaluation of slot filler devices (buttons) to resolve the problem.		

Accession For	
NTIS GRA&I	<input checked="" type="checkbox"/>
DTIC TAB	<input type="checkbox"/>
Unannounced	<input type="checkbox"/>
Justification	
By	
Distribution/	
Availability Code	
Avail and/or	
Special	
A	

DD FORM 1473 1 JAN 73

EDITION OF 1 NOV 65 IS OBSOLETE
S/N 0102-014-6601

UNCLASSIFIED

SECURITY CLASSIFICATION OF THIS PAGE (When Data Entered)

SUMMARY

A. BACKGROUND

1. In March 1978, the No. 4 CDP (cross deck pendant) aboard the USS JOHN F. KENNEDY (CV 67) parted during an F-14 aircraft arrestment resulting in the loss of the aircraft. It was determined through a failure analysis, reference (a), that the pendant failed as a result of damage incurred when it was retracted after falling into the No. 3 catapult track slot.

2. This report documents the investigation of the accident conducted at the NAVAIRENGCEN (Naval Air Engineering Center) from April 1978 to March 1979. Included are the results of a survey to determine the scope of the problem, tests to confirm the failure sequence, and the progress made toward resolving the problem.

B. PROCEDURES AND RESULTS:

During this investigation, the problem of controlling the hazard introduced by the retraction of pendants which have fallen into the No. 3 catapult track slot was approached in several ways.

1. Fleet data on crossdeck pendant entry into the catapult track slot, resultant cable damage and pertinent operational information was analyzed to define the scope and magnitude of the problem. Results indicated that the crossdeck pendant entered the slot in less than 10 percent of arrestments (no cable damage was reported). OFF-CENTER-to-port engagements and a port deck list appeared to contribute to the frequency of cable/slot interaction during retraction.

2. Efforts aimed at duplicating the CV 67 pendant failure at the NAVAIRENGCEN test site met with mixed results. Cables damaged by being dragged through catapult slots, either aboard ship or at NAVAIRENGCEN, were subjected to repeated high energy deadload engagements. Although inspection of the crossdeck pendants prior to testing disclosed the severe localized abrasion pattern described in reference (a), none of the pendants parted despite numerous wire breaks. Nevertheless, similarities between the cable damage during tests and the cable condition following the CV 67 accident validate the conclusion reached in reference (a), that the accident was precipitated by damage incurred by the pendant being retracted wholly or partially in the track slot.

3. Physically preventing the cable from entering the slot by crimping sleeves or collars on the crossdeck pendant proved ineffective. No suitable method of retaining the collars or sleeves on the pendant could be devised and the effort was discontinued. An effective slot cover consisting of buttons, PN 519282, spaced at intervals along the slot was developed. These devices were operationally tested on three ships and found to be functionally satisfactory (refer to trip reports in Appendix D).

Ref: (a) NAEC Preliminary Report No. 91-1, Failure Analysis of CV 67 Cross Deck Pendant; preliminary report, A. Hittner, 14 April 1978

4. Combinations of larger diameter crossdeck pendants, coupled with a reduced slot width, have been investigated with the results in Table 1. Further efforts along these lines depend upon operational requirements and the availability of funding. In addition, 11 other slot filler devices, described in Appendix A, have been proposed.

5. Shipboard operations will confirm or deny the practicality of the button solution. The other alternatives, noted in paragraph B4, will be held in abeyance until such determination can be made and additional funding is provided.

C. CONCLUSIONS

1. Tests on three ships have shown that buttons are a workable technique for keeping the crossdeck pendant out of the slot. This technique should then prevent damage of the type which caused the F-14 accident on CV 67.

2. Alternate slot cover approaches, including reduced slot widths and larger crossdeck pendants, have been evaluated to replace the buttons, and the four most promising ideas have been identified for further development if needed. These are:

- a. Swing bars
- b. Tandem stanchion
- c. Slot/Crossdeck pendant modification No. 2
- d. Single stanchion

These concepts are described in detail in Section IIID, and Appendices A and B.

TABLE OF CONTENTS

<u>Section</u>	<u>Subject</u>	<u>Page</u>
	SUMMARY.	1
	A. BACKGROUND	1
	B. PROCEDURES AND RESULTS	1
	C. CONCLUSIONS.	2
	LIST OF FIGURES & LIST OF TABLES	4
I	INTRODUCTION	5
II	EQUIPMENT AND PROCEDURES	6
III	RESULTS AND DISCUSSION	10
	A. RESULTS OF FLEET SURVEY.	10
	B. RESULTS OF TESTS WITH DAMAGED CROSSDECK PENDANTS	10
	C. DEVELOPMENT TESTING OF BUTTONS	17
	D. DEVELOPMENT OF ALTERNATE SOLUTIONS	18
IV	CONCLUSIONS.	20
V	ACTIONS TAKEN.	21
VI	REFERENCES	21
	APPENDIX A - ALTERNATE DESIGN PROPOSALS	23
	APPENDIX B - EVALUATION OF ALTERNATE DESIGN PROPOSALS	35
	APPENDIX C - RECOVERY SYSTEM PERFORMANCE AS A FUNCTION OF CDP SIZE	41
	APPENDIX D - TRIP REPORTS TO THE USS KITTY HAWK (CV63) AND USS JOHN F. KENNEDY (CV 67)	47

LIST OF FIGURES

<u>Figure</u>	<u>Title</u>	<u>Page</u>
1	Existing Shuttle/Track Slot Clearance	7

LIST OF TABLES

<u>Table</u>	<u>Title</u>	<u>Page</u>
1	CATAPULT SLOT/DECK PENDANT MODIFICATIONS	9
2	FLEET DATA SUMMARY OF DECK PENDANT/PURCHASE CABLE INTERACTION WITH NO. 3 CATAPULT TRACK SLOT	11,12,13
3	TEST DATA OF DAMAGED CROSSDECK PENDANTS	14,15,16

I. INTRODUCTION

1. Reference (a) concluded that the failure of the No. 4 crossdeck pendant which led to the loss of an F-14A aircraft aboard the CV 67 on 30 March 1978, was caused by localized abrasion and burning of the outer layer wires. This failure occurred as a result of the cable falling into the No. 3 catapult track slot, prior to, or while being retracted to BATTERY, and the friction generated between the upper edge of the track cover and outer layer wires during retraction. Wire damage was probably inflicted progressively prior to the engagement which failed the crossdeck pendant.

2. As a result of the failure analysis, operating procedures were adopted requiring arresting gear personnel to avoid retracting the engine if the crossdeck falls into the slot until the cable is lifted out, or, should the gear be retracted with the crossdeck pendant in the slot, to thoroughly inspect the cable for damage prior to the next engagement. These procedures were intended as temporary safety measures until a suitable solution could be devised to eliminate the problem.

3. In addition to the above, statistical data from the fleet concerning the frequency of cable/slot interaction, observed damage, and other pertinent information was solicited in order to determine the extent of the problem.

4. The NAVAIRENGCEN also focused on the following tasks:

a. Duplicating the CV 67 failure by high energy deadload engagements into crossdeck pendants damaged to varying degrees by being retracted while in the track slot.

b. Developing a device to prevent the cable from entering the slot by either mechanically covering the slot or installing collars or sleeves on the crossdeck pendant to enlarge pendant diameter.

c. Investigating the feasibility of reducing the width of the slot.

5. During April and May 1978, a prototype device consisting of an aluminum filler strip with two end caps to retain the strip in the slot was tested. This device did prevent entry of the crossdeck pendant into the slot; however, due to the vulnerability of the aluminum filler strips to damage inflicted by a hook strike, these strips were removed and the tests were repeated with only the end caps in place. Results were similar to those obtained with the filler strips. A maximum spacing of 7 feet between caps was required to prevent cable entry into the slot. No cable damage was noted during retraction tests with this spacing. Development effort was then concentrated on refining these caps, later designated as buttons because of their shape, to serve as interim slot filler devices. The modified buttons were successfully tested on CV 67, CV 63 and CV 66.

6. Meanwhile, attempts to devise suitable sleeves or collars for the crossdeck pendant which would resist hook abrasion and impact, and at the same time, not appreciably affect the dynamics of the pendant, were proving fruitless. Anything strong enough to withstand hook impact and sliding would be massive enough to alter the dynamics of the cable.

7. Studies to determine whether the slot could be narrowed sufficiently to prevent cable entry focused on permissible modifications of the shuttle throat and guide blocks (see Figure 1).

8. As a result of these studies, alternative designs and concepts to cover the slot during recovery operations were explored and evaluated against the existing buttons to find the most promising catapult slot modifications for further development. The evaluation procedure was subsequently enlarged in scope to include several options involving shuttle and guide block modifications combined with increases in crossdeck pendant diameter, which would make it physically impossible for the cable to enter the slot.

9. Buttons were initially tested on three ships before being committed to production. As a result of these trials, useful data on the optimum number and spacing of the buttons, installation and removal procedures, and crew reactions and comments have been accumulated to aid in design improvements to enhance reliability and safety, and reduce maintenance and handling problems with these devices.

II. EQUIPMENT AND PROCEDURES

A. Deadload and catapult test sites were used to evaluate the following:

1. Increasing effective crossdeck pendant diameter by means of sleeves or collars.

a. Aluminum sheet wrap crimped to the crossdeck pendant in 2-inch lengths every 5 feet.

b. Seizing wire wrapped around crossdeck pendant in 6-inch lengths every 5 feet.

c. Steel bands, 3 inches wide, swaged to the crossdeck pendant at 5-foot intervals.

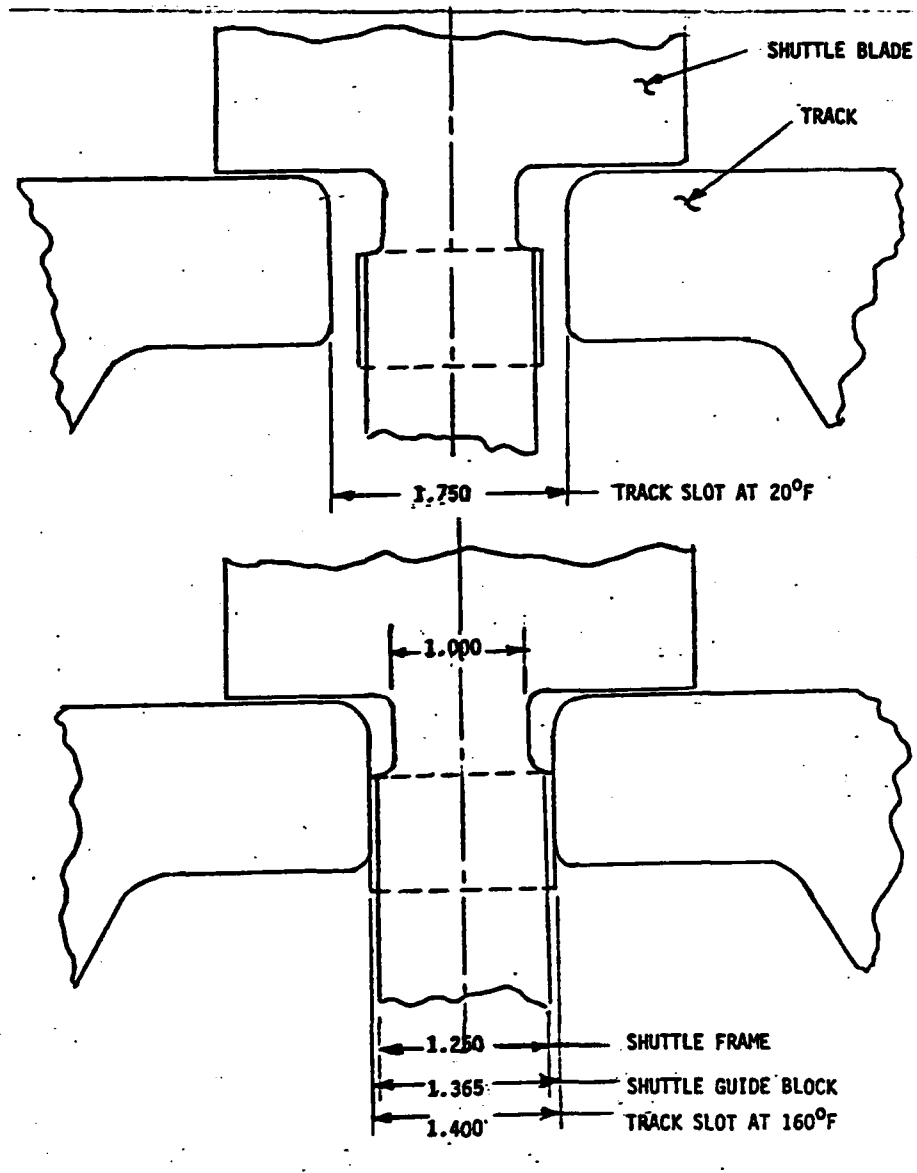

Figure 1. Existing Shuttle/Track Slot Clearance

NAEC-91-7964

2. Tests to destruction of pendants damaged in varying degrees by being retracted in the slot. A 63,000-pound-deadload engagement, 5 feet OFF-CENTER at 105 to 115 knots was used.

<u>No. of Pendants</u>	<u>Damaged Pendants From:</u>
1	CV 67
1	CVN 69
2	RALS
1	TC13 Catapult

The above deadload tests were conducted at RSTS (Recovery System Track Site) No. 4, equipped with a Mark 7 Mod 2 Arresting Gear System.

3. Tests of slot covers consisting of caps or buttons, with and without sheet metal filler strips connecting the buttons. Tests were conducted at the TC-13 Catapult site, and consisted of five retractions of the crossdeck pendant over the track slot with the test device installed. The crossdeck pendant is inspected after each retraction.

4. Hook-impact tests at RSTS No. 3 and 4 to evaluate the resistance of the buttons to hook strike. A deadload was equipped with an F-4 tailhook assembly which impacted the test specimen installed on the deck.

B. A survey of statistical data from the fleet was initiated by reference (b). Information requested concerned the percentage of arrests in which the cross-deck pendant and/or purchase cable enters the slot, the length of cable in the slot, and pertinent information on OFF-CENTER conditions, deck list, and sea state which may correlate with cable/slot interaction.

C. The following proposals were analyzed and evaluated:

1. Eleven designs for devices to keep the cable out of the slot. (see Appendix A). These were evaluated using the emphasis curve technique described in Appendix B.

2. Four proposals for narrowing the slot width, increasing the crossdeck pendant diameter, or both (see Table 1). These were evaluated by the emphasis curve method against the 11 designs above.

Ref: (b) NAVAIRENGCEN msg 112243Z Apr 1978: Interaction of No. 3 Cat. Slot; Request For Survey of

TABLE 1 -- CATAPULT SLOT/DECK PENDANT MODIFICATIONS

PROPOSAL	RESULTING SLOT/ SHUTTLE DIMENSIONS	PENDANT SIZE REQD	LAUNCHING	IMPACT OF CHANGES	RECOVERY
1. Reduced guide block dimensions only. Shim track covers to provide min clearance	Max. slot width (cold) = 1.65" Min slot width (hot) = 1.30" Guide block width = 1.280"	1-5/8" nom (Approx 1.71" OD)*	a. Increased frequency of inspection for guide wear b. Increased frequency of inspection for track alignment c. Logistical support		a. Redesign of hook points on all aircraft (major effort) b. MK 7 Mod 2 Performance Penalty ENG VEL LIMIT WOD ACFT WAS NOM REQD F-4J 126 123 23 A-4 125 107 26 A-7E 134 114 26 c. Recalibration of arresting gear d. Development and certification of terminal swaging equipment and techniques. Terminal redesign. e. Logistical Support.
2. Reduced guide block plus reduced shuttle thickness to 1.125".	Max. slot width (cold) = 1.525" Min slot width (hot) = 1.175" Guide block width = 1.280"	1-1/2" nom (Approx 1.57" OD)*	a. Same as la. b. Same as lb. c. No shuttle wear allowance available. Increased shuttle replacement frequency. d. Shuttle strength reduced: COND BAR LOAD F-14 Max. 232,000 oper load Max. cycle 281,000 test load RA-5C, A-3A, EA-3 e. Same as lc.	F.S. LIFE WAS NOW WAS NOW 2.31 1.99 23,900 20,250 1.71 1.55 14,000 1,500	a. MK 7 Mod 2 Performance Penalty ENG VEL LIMIT WOD ACFT WAS NOM REQD A-4 125 116 16 A-7E 134 124 15 b. Same as lc. c. Same as le.
3. Reduced guide block plus reduced shuttle thickness to 1.000".	Max. slot width (cold) = 1.400" Min slot width (hot) = 1.050" Guide block width = 1.280"	1-3/8" nom (Approx 1.44" OD)* (Std MK 7 Pendant)	a. Same as la. b. Same as lb. c. Same as 2c. COND BAR LOAD F-14 Max. 232,000 oper load Max. cycle 281,000 test load e. Same as lc.	F.S. LIFE WAS NOW WAS NOW 2.40 1.62 29,000 6,000 1.71 1.30 14,000 350	None
4. No slot changes. Larger pendant.	Max. slot width (cold) = 1.75"	1-3/4" nom (Approx. 1.83" OD)*	None		a. Same as la. b. MK 7 Mod 2 Performance Penalty Min WOD in excess of 30 knots. Reqd for most acct up to 40000-Lb Wt. c. Same as lc. d. Same as ld. e. Same as le.

* New Cable. Some reduction in OD occurs as cable stretches.

III. RESULTS AND DISCUSSION

A. RESULTS OF FLEET SURVEY

1. Table 2 summarizes the information received from waist-catapult-equipped CVs, in reply to a request for information on incidence of purchase cables and/or crossdeck pendants falling into the slot during retraction, cable damage experienced, OFF-CENTER engagement position, deck list, and other factors which may have some bearing on the problem.

2. The frequency of cable entering the slot is less than 10 percent of the total number of arrestments for all the reporting ships. (No cable damage is reported when retraction occurred with the crossdeck pendant in the slot). The USS CONSTELLATION (CV 64) noted a correlation between the position of the port purchase cable socket relative to the starboard bridle arrester track, and the incidence of cable entering the slot. The ship proposes a procedure whereby the deck crew repositions the socket to the right of the starboard bridle arrester track prior to retraction. In the absence of similar occurrences observed on other ships, CV 64 experience may pertain only to that ship's deck configuration. Consequently, it was decided to retain the requirement to lift the cable out of the slot prior to retraction as a standard operating procedure.

3. It is agreed that OFF-CENTER-to-port engagements and/or a port deck list contribute to the incidence of cable/slot interaction. However, these parameters are not subject to control at the instant of wire pickup.

B. RESULTS OF TESTS WITH DAMAGED CDP'S

1. The purpose of these tests was to try to duplicate the catastrophic failure which occurred on CV 67 when an F-14 aircraft engaged a previously damaged crossdeck pendant. Duplicating the failure would support the findings of the failure analysis, reference (a), that the crossdeck pendant parted because of the loss of cable strength due to damage inflicted by friction between the cable and slot during retraction.

2. To simulate a high-energy arrestment, a 63,000-pound deadload engagement into a Mark 7 Mod 2 Arresting Gear at 105 to 115 knots was employed at RSTS No. 4. A 5-foot OFF-CENTER-to-starboard (inner reeve) engaging position was chosen to provide the maximum cable tension differential consistent with normal shipboard operating conditions.

3. Table 3 shows the data accumulated on the four crossdeck pendants tested. The number of engagements sustained by each crossdeck pendant before removal varied from a minimum of 7 to a maximum of 35. Criterion for removal

TABLE 2 — FLEET DATA SUMMARY OF DECK PENDANT/PURCHASE CABLE INTERACTION WITH NO. 3 CATAPULT TRACK SLOT

SHIP (MSG NO.)	TOTAL ARRESTS.	NO. OF INCIDENTS OF CABLE FALLING IN SLOT		PERCENT OF ARRESTS. WHERE CDP/PC FALLS IN SLOT				CABLE DAMAGE REPORTED	EFFECT OF LIST	COMMENTS
		NO.	PERCENT	1	2	3	4			
ENTERPRISE (291717Z APR 78)	(4/6 to 4/20) 1141	50	4.4	0/0	4.8/.48	4.8/.32	3.6/0	None	Insignificant	Majority of incidents occur early in retract cycle. When this occurs retract stopped and cable lifted out of slot.
NIMITZ (310900Z MAR 78)	-	-	-	-	-	"Several times during each recovery"	-	None	-	Inspection of crossdeck pendants before and after each recovery failed to disclose wear patterns observed on KENNEDY.
KITTY HAWK (251116Z APR 78)	-	-	-	0/0	1/0	4/4	3/3	None	Port list > 10° doubles probability of cable falling in slot.	Average length of PC falling in slot = 50'. Average length of crossdeck pendant falling in slot = 13'. Arrest > 5' OFF-CENTER-co-port doubles probability of cable falling in slot.
FORRESTAL (270057Z APR 78)	712	0	0	0	0	"Three instances of crossdeck pendant falling in slot in last 10 months"	0	None	1/20° port list when crossdeck pendant has fallen in slot. Normal deck list = 0° to 10° STBD during recovery.	

TABLE 2 FLEET DATA SUMMARY OF DECK PENDANT/PURCHASE CABLE INTERACTION WITH NO. 3 CATAPULT TRACK SLOT (CONTD)

SHIP (MSG NO.)	TOTAL ARRESTS.	NO. OF INCIDENTS OF CABLE FALLING IN SLOT		PERCENT OF ARRESTS. WHERE CDP/PC FALLS IN SLOT				CABLE DAMAGE REPORTED	EFFECT OF LIST	COMMENTS
		NO.	PERCENT	1	2	3	4			
WIRITZ (122156Z AUG 78)	637		(6/15 - 6/19, 6/27, 7/6/78 Time Period)	0.0	.6/1.7	5.7/2.7	4/4	None	-	Removal of cable from slot prior to retraction or inspection following retraction frequently resulted in foul deck w/o (wave-off). Slot seals have been used. Problems with delay in insertion and dislodgment by jet blast or wire retraction.
EISENHOWER (161331Z AUG 78)	770	10	1.3	0.0	0.0	.66/.66	.97/.32	None	All instances of interactions occurred with 1/20 port list.	All instances occurred OFF-CTR-to-port eng'mts of 5' or more w/o's during inspection of crossdeck pendant extends recovery times.
RANGER (142051Z AUG 78)	-	(6/78 - 7/78) 1 (May have fallen in)	-	-	-	-	-	None	Maintaining minimum list considered effective procedure.	Physical relationship between waist cats and deck sheaves minimizes possibility of crossdeck pendant falling into cat slot. Close monitoring of cable torque buildup considered effective procedure.

TABLE 2 FLEET DATA SUMMARY OF DECK PENDANT/PURCHASE CABLE INTERACTION WITH NO. 3 CATAPULT TRACK SLOT (CONTD)

SHIP (NSG NO.)	TOTAL ARRESTS.	NO. OF INCIDENTS OF CABLE FALLING IN SLOT		PERCENT OF ARRESTS, WHERE CDP/PC FALLS IN SLOT				CABLE DAMAGE REPORTED	EFFECT OF LIST	COMMENTS
		NO.	PERCENT	1	2	3	4			
CORAL SEA (0822162)	-	-	-	0	0	0	0	-	-	Crossdeck pendant removed from slot prior to retract.
CONSTELLATION (1216162 MAY 78) (Amended by 1121542 AUG 78)	(4/24 - 4/28 Time Period) 163 ON-CTR 18 OFF-CTR Port 11 OFF-CTR Stbd <u>192</u>	9 14 4 0 <u>18</u>	22 22 0 <u>9.4</u>	0/10	3/3	11/1	12/8	None	0° to 1.5° stbd list during operations. Variation not sufficient to provide correlation between list and occurrence of cable entering slot. Amended msg says somewhat higher incidence of occurrence with port list.	4 Carquais with F-14, A-6, A-7, EA-6, S-3 A/C. Position of port socket relative to bridle arrester stbd track prior to retract is significant. Higher probability of cable falling in slot indicated when socket falls to left of B/A track. Recommended that socket be repositioned to right of B/A track prior to retract to preclude cable falling in slot.
AMERICA (1217322 JUN 78)	(5/20 - 6/8 Time Period) 1521	127 (5 of these were PC)	8.4	-	9	8	11	None	Deck level during majority of time	Approx length of PC in slot varied from 2' to 25'. Avg length of crossdeck pendant in slot was 15'. No correlation between OFF-CENTER hits, drifts, acct speed or type. Opinion of observers that jet blast from acct clearing landing area is primary cause factor in cable dropping in slot.

NAEC-91-7964

TABLE 3 - TEST DATA OF DAMAGED PENDANTS

RSTS NO. 4

Deadload Weight = 63,000 Lb; Weight Setting = 52,000 Lb

EVENT NO.	1978 DATE	PENDANT IDENTIFICATION	ENGAGING VEL (KN)	MAXIMUM CABLE TENSION (1,000 LB)		COMMENTS
				PORT	STBD	
1	7/19	Returned	104	61.2	68	
2		from CV 67	105	61	67	
3			105	62	68	
4			106	60	70	
5	7/20		105	61	67	
6			106	63	70	
7			105	63	70	
8			105	62	72	
9			105	60	69	
10			106	62	72	
11			106	60	72	
12			105	61	72	
13			106	62	72	
14	7/21		104	57	64	
15	7/24		103	58	66	Removed; damage in hook impact area.
1		Returned	98	-	-	
2		from CVN 69	110	64	74	2 BW, Strand burned
3			110	67	76	3 BW
4	7/25		110	67	76	6 BW
5			110	63	75	
6			111	67	78	
7			113	66	81	
8			113	67	78	
9			113	67	79	
10			113	69	80	
11			113	64	79	
12	7/26		113	67	79	
13			109	63	72	8 BW
14			112	65	78	9 BW
15			112	62	79	
16			110	64	78	
17			112	63	79	
18	7/27		110	63	77	10 BW
19			110	64	76	11 BW
20			110	60	76	15 BW

RSTS = Recovery System Track Site

TABLE 3 - TEST DATA OF DAMAGED PENDANTS (CONTD)

RSTS NO. 4

Deadload Weight = 63,000 Lb; Weight Setting = 52,000 Lb

EVENT NO.	1978 DATE	PENDANT IDENTIFICATION	ENGAGING VEL (KN)	MAXIMUM CABLE TENSION (1,000 LB)		COMMENTS
				PORT	STBD	
21			110	61	78	16 BW
22			111	63	78	18 BW
23			110	62	77	
24			110	62	77	19 BW
25			111	64	78	21 BW
26	7/27		110	62	79	23 BW
27	7/28		107	61	72	26 BW
28			108	60	72	
29			110	61	72	
30			110	61	74	30 BW
31			109	61	74	33 BW
32			110	62	77	35 BW
33			110	61	74	38 BW
34			110	60	70	40 BW Pendant Removed
1	7/31	RALS Test	110	64	75	4 BW at start
2		Pendant	109	64	74	
3			109	62	73	
4			110	62	74	
5	8/1		110	64	75	
6			112	65	77	5 BW
7			76	-	-	
8			110	64	77	
9			110	63	78	
10			111	62	79	6 BW
11			111	64	77	7 BW
12			112	65	78	
13			111	65	78	
14	8/2		109	62	73	
15			110	64	77	
16			112	64	78	
17			110	64	77	10 BW
18			111	64	78	
19	8/3		109	61	77	

RALS = Runway Arrested Landing Site

BW = Broken wires

NAEC-91-7964

TABLE 3 - TEST DATA OF DAMAGED PENDANTS (CONTD)

RSTS NO. 4

Deadload Weight = 63,000 Lb; Weight Setting = 52,000 Lb

EVENT NO.	1978 DATE	PENDANT IDENTIFICATION	ENGAGING VEL (KN)	MAXIMUM CABLE TENSION (1,000 LB)		COMMENTS
				PORT	STBD	
20			108	65	77	
21			111	62	78	
22			110	62	78	12 BW
23			110	61	77	
24			111	67	79	2 Fixed Sheaves Failed, Pendant Removed
1	8/24	RALS Test Pendant	111	63	70	12 BW at start 25 BW after
2			110	63	72	29 BW
3			111	65	72	
4			112	65	73	32 BW
5			111	64	74	34 BW
6	8/24		111	62	73	36 BW
7			-	-	-	40 BW Pendant Removed
1	8/23	TC13 Test	111	65	74	
2	8/29	Pendant	114	72	79	6 BW
3			116	72	80	8 BW
4	8/30		118	76	83	
5			118	76	83	
6			118	72	83	
7			116	72	79	
8			117	72	82	12 BW
9			115	68	79	
10			116	67	82	13 BW
11			116	70	80	
12			115	66	83	
13			116	67	86	14 BW
14			115	65	85	Pendant Removed

TC13 Catapult Track

was imminent failure of the crossdeck pendant. Despite the initial damage and the progressive increase in broken wires, none of the crossdeck pendants parted. The large number of broken wires observed is attributed, at least in part, to the abrasion incurred as the crossdeck pendants were dragged along the concrete surface of the test site during runout and retraction. In this respect, the test environment was more severe than that encountered in shipboard operations.

4. Although no crossdeck pendants parted, the rapid and progressive deterioration of the cable demonstrated the potential for significantly reducing crossdeck pendant life expectancy. The fact that the test cables did not part probably indicates that the damage sustained by the CV 67 crossdeck pendant, prior to the accident, was more severe or repetitive in one location on the cable than could be induced by deliberately dragging the cable through the slot. In this case, the failure mode exhibited on CV 67 may be unique in the sense that a certain undefined sequence of events must take place, beginning with the cable being retracted in the slot.

C. DEVELOPMENT TESTING OF BUTTONS

1. The track slot buttons, PN 519282, presently in service with the Fleet, originated in April 1978, as anchors for the aluminum filler strip which was to cover the slot. The combination of strips and anchors proved to be cumbersome and difficult to install in tests at NAVAIRENGCEN. Further testing using the anchors only, spaced at 7-foot intervals, indicated the crossdeck pendant could be effectively kept out of the slot. Single-lock buttons were tested, but were found inadequate, due to a tendency to slide along or be dislodged from the track under hook impact. Aluminum buttons to reduce weight were also tested and proved to be vulnerable to damage from hook impact. The buttons were then redesigned with two lock bolts and tested at NAVAIRENGCEN for resistance to hook impact and cable drag loads.

2. Tests proved satisfactory, and sufficient buttons were manufactured for shipboard testing commencing in November 1978.

3. The first ship to have the modified buttons installed for operational tests was the CV 67. The optimum number of buttons was found to be 18, with the last button 195 feet from the aft end of the No. 3 catapult track slot. Installation and removal time by 3 crewmen was consistently under 2-1/2 minutes. With the exception of modifications suggested for the cart used to transport the buttons, and the installation tool, comments from the crew were generally favorable.

4. The 18-button configuration did not eliminate the possibility of cable entry into the slot. In one of 63 arrestments the crossdeck pendant did fall in forward of the last button; however, the cable was ejected during retraction. Consequently, the use of additional buttons to cover the full

runout length was not considered warranted in view of the additional time required for installation and removal. No cable damage could be seen in any case where the crossdeck pendant entered the slot, either forward of the last button or between buttons.

5. In December 1978 and January 1979, the buttons were tested on CV 63. With 12 buttons installed, the crossdeck pendant fell into the slot 6 times in 317 retractions with no observable damage. Again, the reaction of the crew was largely favorable with some concern expressed for the possibility of one or more buttons being inadvertently left in the slot at the start of launch operations.

6. Additional operational trials with buttons took place on the CV 66 in March 1979. As on CV 67, 18 buttons were required to minimize cable/slot interaction. The buttons operated satisfactorily during the test period.

7. It was concluded that the buttons effectively eliminated the possibility of severe wire damage due to abrasion and burning induced by prolonged contact with the slot.

D. DEVELOPMENT OF ALTERNATE SOLUTIONS

1. In addition to the buttons, a parallel effort was undertaken to develop an inflatable seal to cover the slot. Due to detail design problems with the pneumatic system and a lack of funding, prototype development has been discontinued.

2. The ultimate solution, in terms of effectiveness and safety, would be the reduction of the track slot width to prevent entry of the crossdeck pendant. The NAVAIRENGCEN has been investigating this concept in order to determine the minimum slot width in terms of the constraints involved and trade-offs required. The problem is complicated by several factors: allowances for thermal expansion, deck structural deflections, track cover assembly tolerances, required shuttle clearance, etc. (see Table 1). Prior to reaching any conclusions, more information is needed concerning ship track cover configurations. Limited funding has precluded additional efforts in this direction.

3. Recognizing that operational trials with the buttons may reveal some unforeseen deficiencies, it was deemed advisable to proceed with alternative concepts. In order to select the most promising concepts for further development from among the many being considered, an analytical technique known as the "emphasis curve" was used. This technique emphasizes the more important parameters to be considered in the selection process while deemphasizing the less important ones. (See Appendix B).

4. A panel of evaluators was chosen representing a cross-section of the NAVAIRENGCEN technical community. This panel's first task was to determine the parameters to be used in the evaluation, and then to rank them in the order of relative importance. Table B-2, Appendix B, shows the 17 parameters chosen, ranked in order of significance.

5. Eleven catapult slot modification designs (including the buttons) were chosen for evaluation. Appendix A describes the 11 proposals. Buttons were included in the group to ensure that each device intended to keep the cable out of the slot was evaluated against the same criteria.

6. Using the scoring procedure, described in Appendix B, the numerical scores assigned to each proposal were totalled and an arithmetic average computed. Resulting average scores for the five highest rated proposals are shown in Table B-4. The buttons scored highest, followed closely by the swing bars (Figure A-6, Appendix A) and the parallel stanchion device (Figure A-2, Appendix A).

7. Before the results of this evaluation could be implemented, it was decided that sufficient data had been accumulated on possible reductions in slot width to include this option in an expanded evaluation of design alternatives. This option actually consisted of four combinations of slot widths and crossdeck pendant diameters to preclude cable entry. Since increases in crossdeck pendant size over the 1-3/8-inch diameter could entail recovery performance penalties due to increased dynamic loads, this parameter was included in the trade-off analysis. (Perhaps any performance penalties could be eliminated by going to a larger crossdeck pendant with the same metallic area). Table 1 lists the four combinations covering the range of options considered, along with estimated impact of these changes on both shuttle strength and life expectancy, and recovery system performance. The performance analysis is presented in Appendix C.

8. These four options were evaluated by the emphasis curve method (Appendix B) by adding the four additional parameters shown in Table B-3, with the relative importance factor assigned to them. This expanded evaluation resulted in the following five proposals, with the highest scores ranked in order:

- a. Buttons.
- b. Swing bars.
- c. Tandem stanchion.
- d. Slot/crossdeck pendant modification No. 2.
- e. Single stanchion.

9. The swing bars and slot/crossdeck pendant-modification No. 2 can be developed, if funding is available, as possible alternatives to the buttons, should the latter not prove feasible as a long-range solution to the problem.

IV. CONCLUSIONS

1. Results of a survey of Fleet experience with interaction between the crossdeck pendant and the track slot indicate that the cable falls into the slot with sufficient frequency to constitute a potential hazard. (Section III, paragraph A2).

2. Operational parameters, such as OFF-CENTER-to-port engagements and a port deck list, appear to contribute to the incidence of cable entering the slot. (Section III, paragraph A3).

3. Sleeves or collars fastened to the CDP to prevent entry into the slot did not prove feasible. These devices are subject to the conflicting requirements that they be sufficiently lightweight to have no appreciable effect on cable dynamics, and at the same time, sturdy enough to withstand hook impact and abrasion. (Section I, paragraph 6)

4. Failure of the CV 67 crossdeck pendant, which led to the loss of an F-14A aircraft, could not be duplicated in deadload tests with pendants damaged by being retracted in the slot. High energy arrests caused numerous broken wires in the test specimens, but no parting of any of the pendants. The damage sustained by the CV 67 crossdeck pendant prior to failure was evidently more severe than could be induced by deliberately dragging the cable through the slot a few times. (Section III, paragraph B4)

5. The buttons, PN 519282, spaced at 6-foot to 12-foot intervals along the slot, have proven to be a workable technique for preventing cable damage during operational tests on three ships. A potential hazard exists should one or more of these devices be inadvertently left in the slot at the start of launch operations. However, the risk is minimized by the design of the cart carrying the buttons and tools which facilitates the rapid counting of buttons removed. In addition, a shuttle traverse along the length of the slot prior to launch to verify that the slot is clear is specified. (Section III, paragraphs C3 to C7)

6. Several alternate design concepts have been selected for further development should a replacement for the buttons be required. These include several mechanical devices and a combination of a reduced slot width and larger crossdeck pendant diameter. Development efforts on these have been halted at this time due to lack of funds. (Section III, paragraph D9)

V. ACTIONS TAKEN

1. Buttons are now in production and in routine service throughout the fleet. The buttons are a less than ideal solution to the problem in view of the diligence required on the part of the crew to ensure their removal prior to launch, and the possibility of a button becoming dislodged and causing foreign object damage. With systematic installation and removal procedures, and the shuttle traverse prior to launch, plus adequate logistical support to ensure the availability of spares, the buttons should effectively control the hazard which culminated in the loss of an F-14 aircraft aboard the CV 67.

VI. REFERENCES

- (a) NAEC Preliminary Report No. 91-1, Failure Analysis of CV 67 Cross Deck Pendant; preliminary report, A. Hittner, 14 April 1978
- (b) NAVAIRENGCEN msg 112243Z Apr 1978: Interaction of Nr. 3 Cat. Slot, request for survey of
- (c) NAEF-ENG-6169, Cable Dynamics, F.O. Ringleb, 27 Dec 1956
- (d) NAEL-ENG-7511, Performance Analysis of Mark 7 Mod 3 Recovery System Based on Aircraft Calibration Tests, J. H. Zurzolo, 1 Aug 1969
- (e) NAEC-ENG-7886, Mark 14 Aircraft Arresting System Performance Analysis Based on Aircraft Tests, R. Barron, 21 May 1976

APPENDIX A - ALTERNATE DESIGN PROPOSALS

1. DESCRIPTION OF ALTERNATE DESIGN PROPOSALS

Design 1 - Single Stanchion: Stanchion folds between cylinders below grab cables. Manually raised with tool inserted through track slot. Lowering occurs when support knuckle is broken and stanchion lowered with tool. Spacing - 6-foot centers. Self storing.

Design 2 - Tandem Stanchion: Same operation as for single stanchion. Spacing - 6 feet apart.

Design 3 - Cable Slot Filler: Small diameter cable under tension would fill slot enough to prevent CDP from falling through. Intermediate supports would be required. Anchor and tensioner permanently installed, cable and intermediate supports remotely stored.

Design 4 - Strip Slot Filler: Steel strip similar to bridle arrester strap would be pulled through shuttle track. The strip would tend to seal the slot because of the spring effect built into the strip. Intermediate supports may be required. Strip and intermediate supports remotely stored.

Design 5 - Pneumatic Seal: An inflatable seal would be inserted into the shuttle track, and when seal is inflated a tongue would fill slot width. Seal remotely stored.

Design 6 - Swing Bar: Shuttle track channel would be machined to accept a pivoted bar that would be swung across slot preventing CDP from entering slot. Permanent installation spaced 6 feet apart.

Design 7 - Bar Filler: Shuttle track channel would be machined to accept pins that are attached to a bar. When installed, bar would fill slot. Spacing - every 6 feet. Remotely stored.

Design 8 - Cable-Pin Filler: Shuttle track channel would be machined to accept pins. Pins inserted in slot and cable placed on top of pins, entire slot would be filled. Remotely stored.

Design 9 - Chain-Pin Filler: Same as Design 8.

Design 10 - Buttons (Ref PN 519282-1): High strength steel, low profile, rectangular-shaped two-latch button. Spaced 6 feet apart, remotely stored.

Design 11 - Jack Screw Seal: Jack screws are inserted into track and wedged against top and bottom surfaces of channel. Spacing 6 feet apart. Remotely stored.

See sketches on pages 24 through 33.

APPENDIX A — ALTERNATE DESIGN PROPOSALS (CONTD)

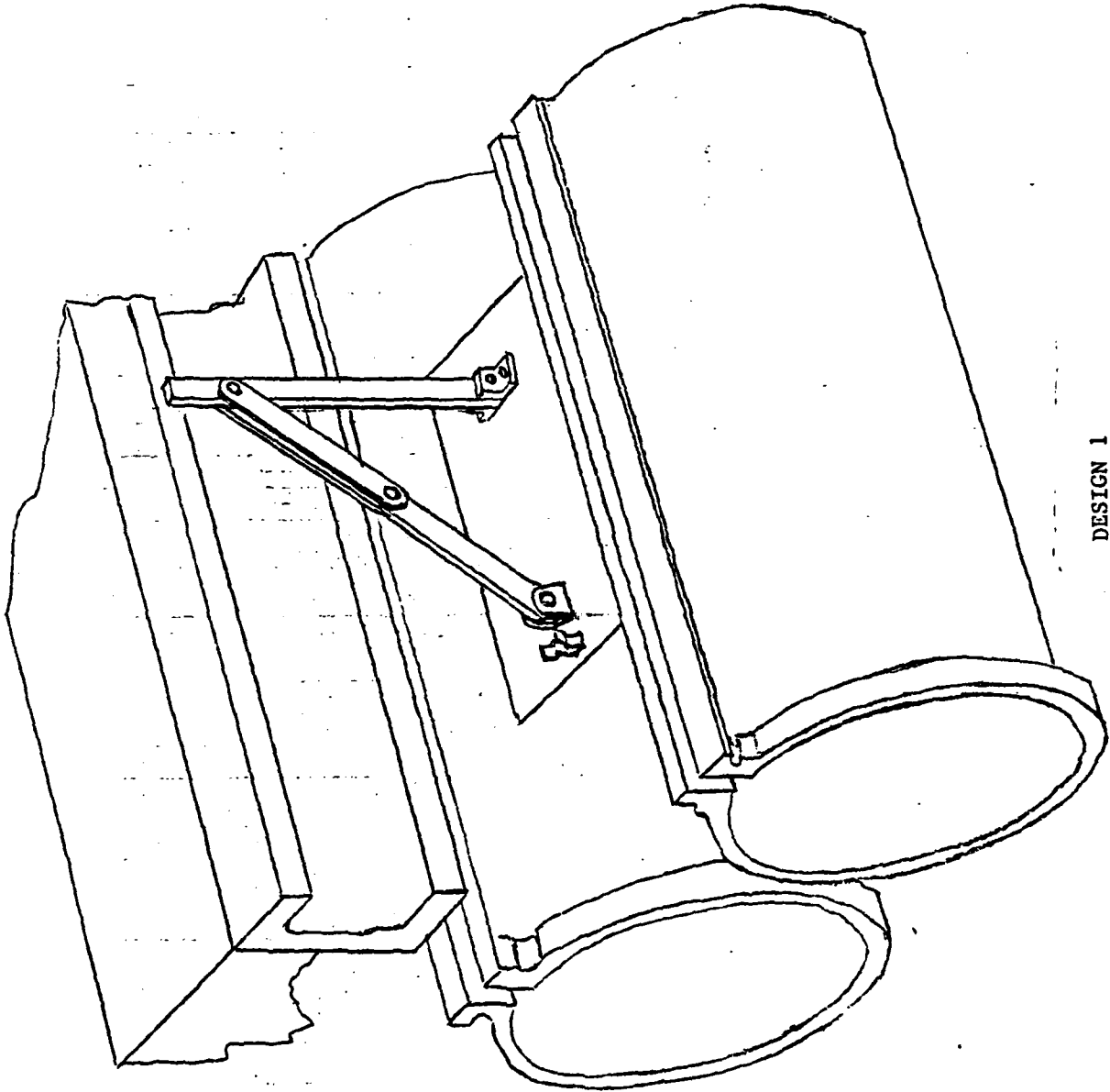

DESIGN 1
FIGURE A-1

APPENDIX A — ALTERNATE DESIGN PROPOSALS (CONTD)

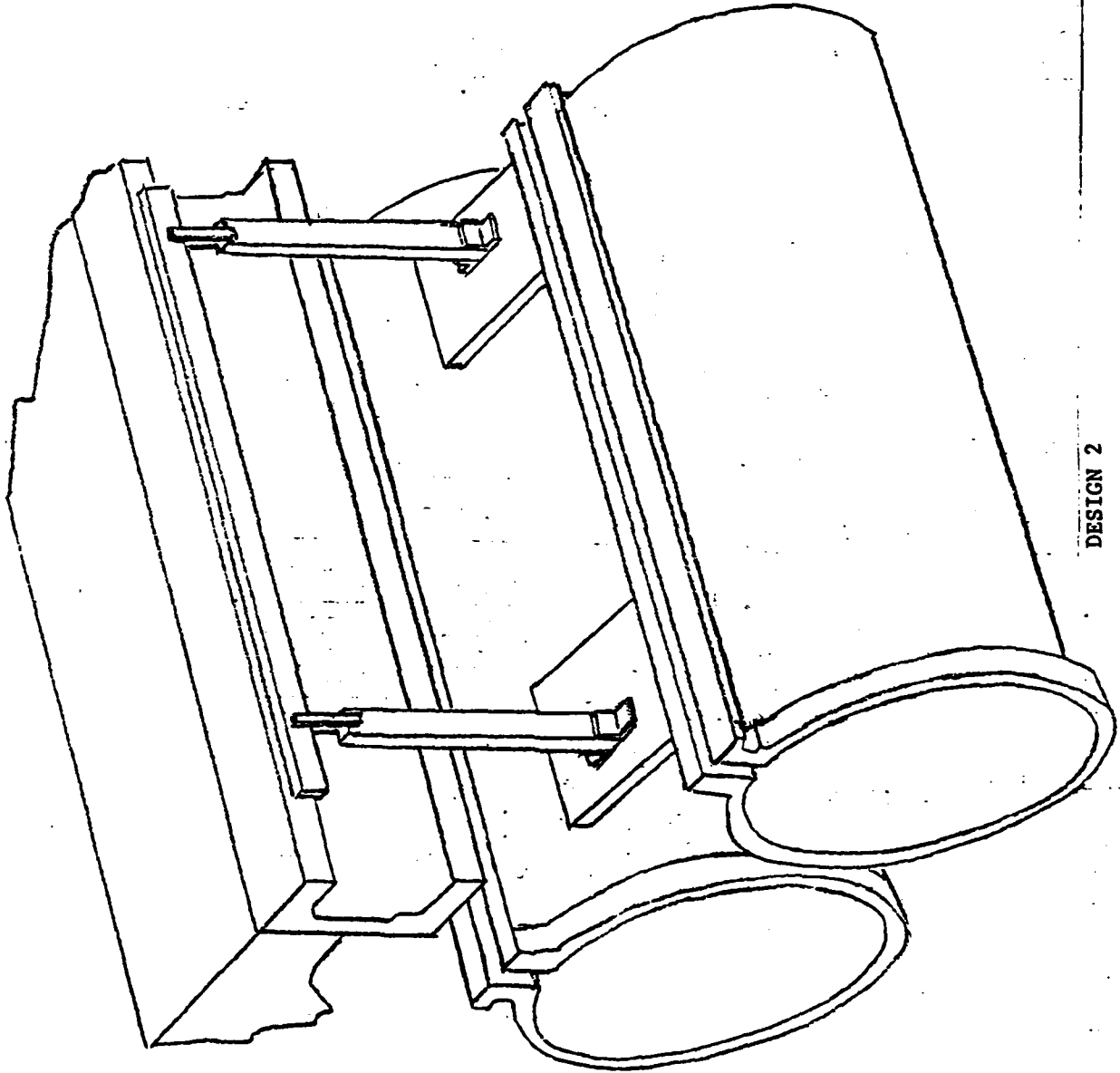

DESIGN 2

FIGURE A-2

APPENDIX A — ALTERNATE DESIGN PROPOSALS (CONTD)

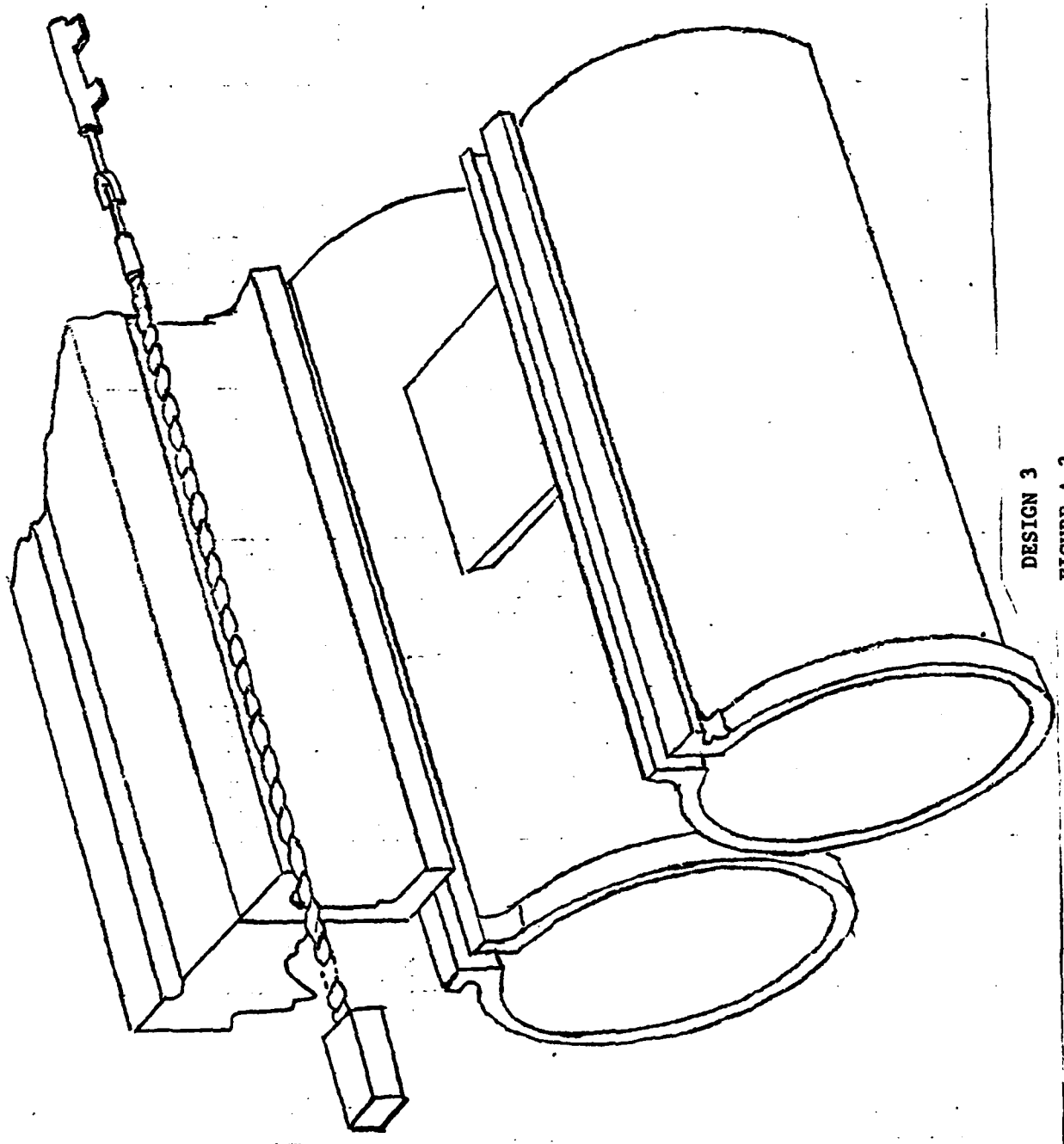

DESIGN 3
FIGURE A-3

APPENDIX A — ALTERNATE DESIGN PROPOSALS (CONTD)

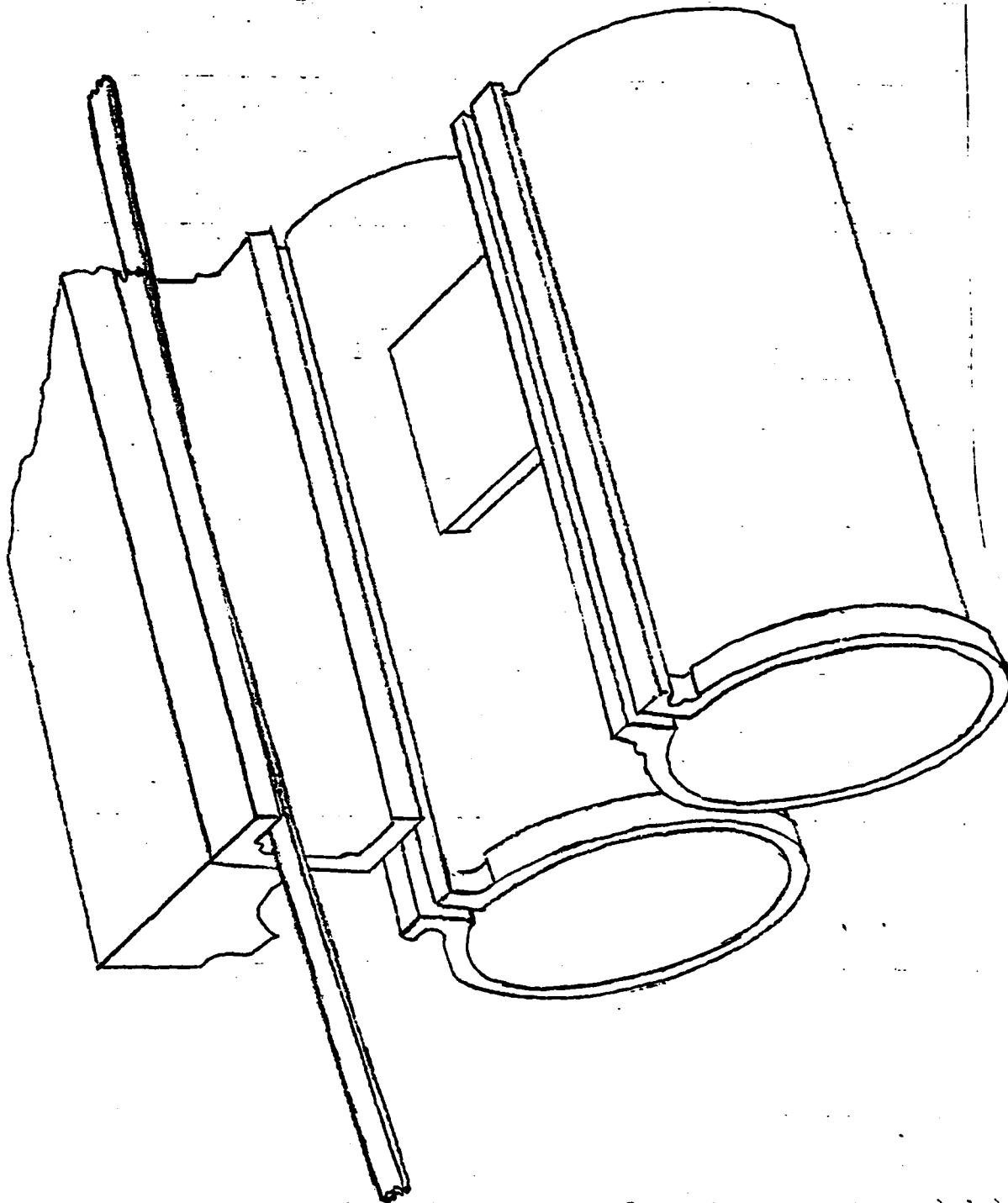

DESIGN 4
FIGURE A-4

APPENDIX A — ALTERNATE DESIGN PROPOSALS (CONTD)

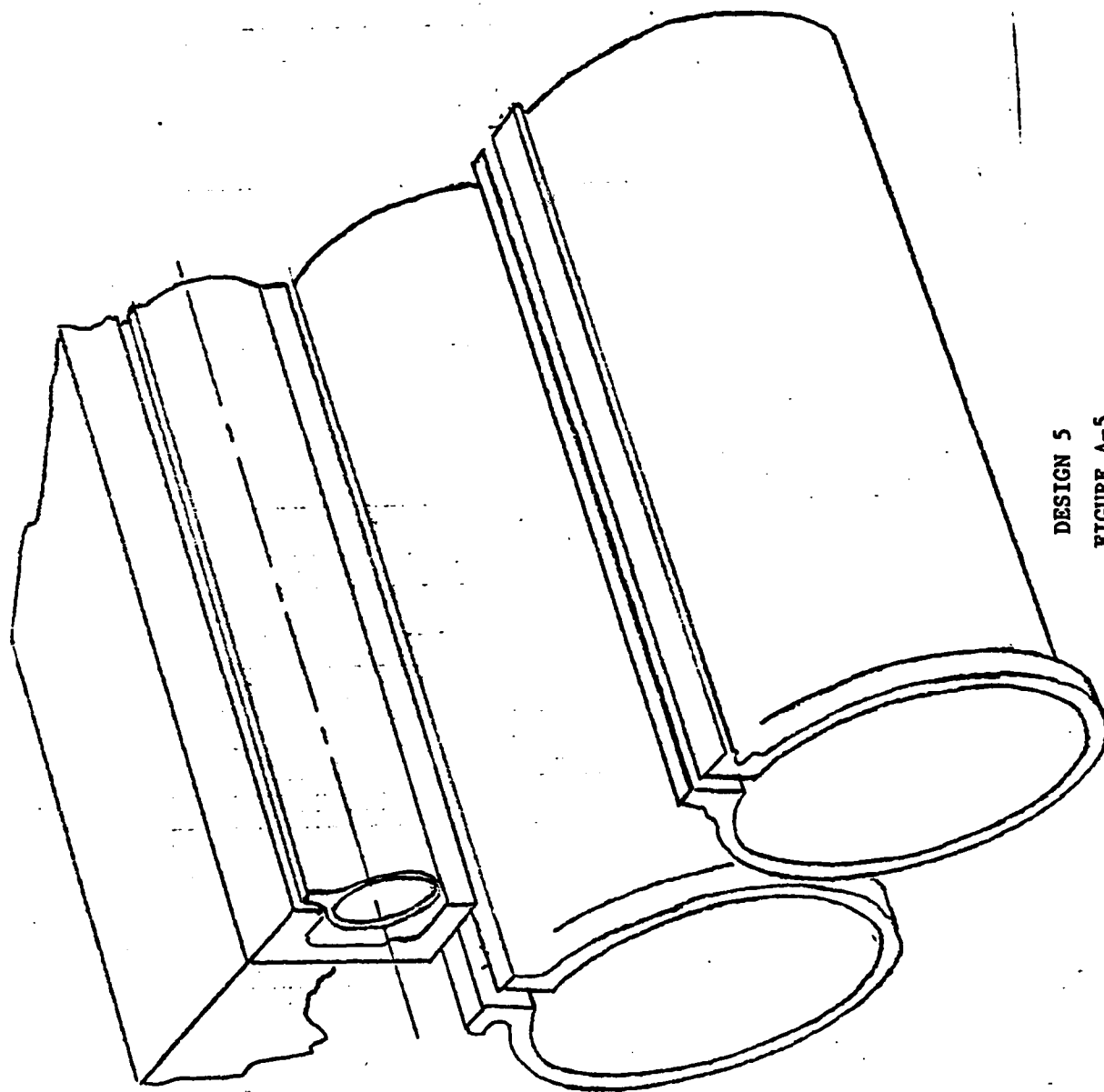

DESIGN 5
FIGURE A-5

APPENDIX A — ALTERNATE DESIGN PROPOSALS (CONTD)

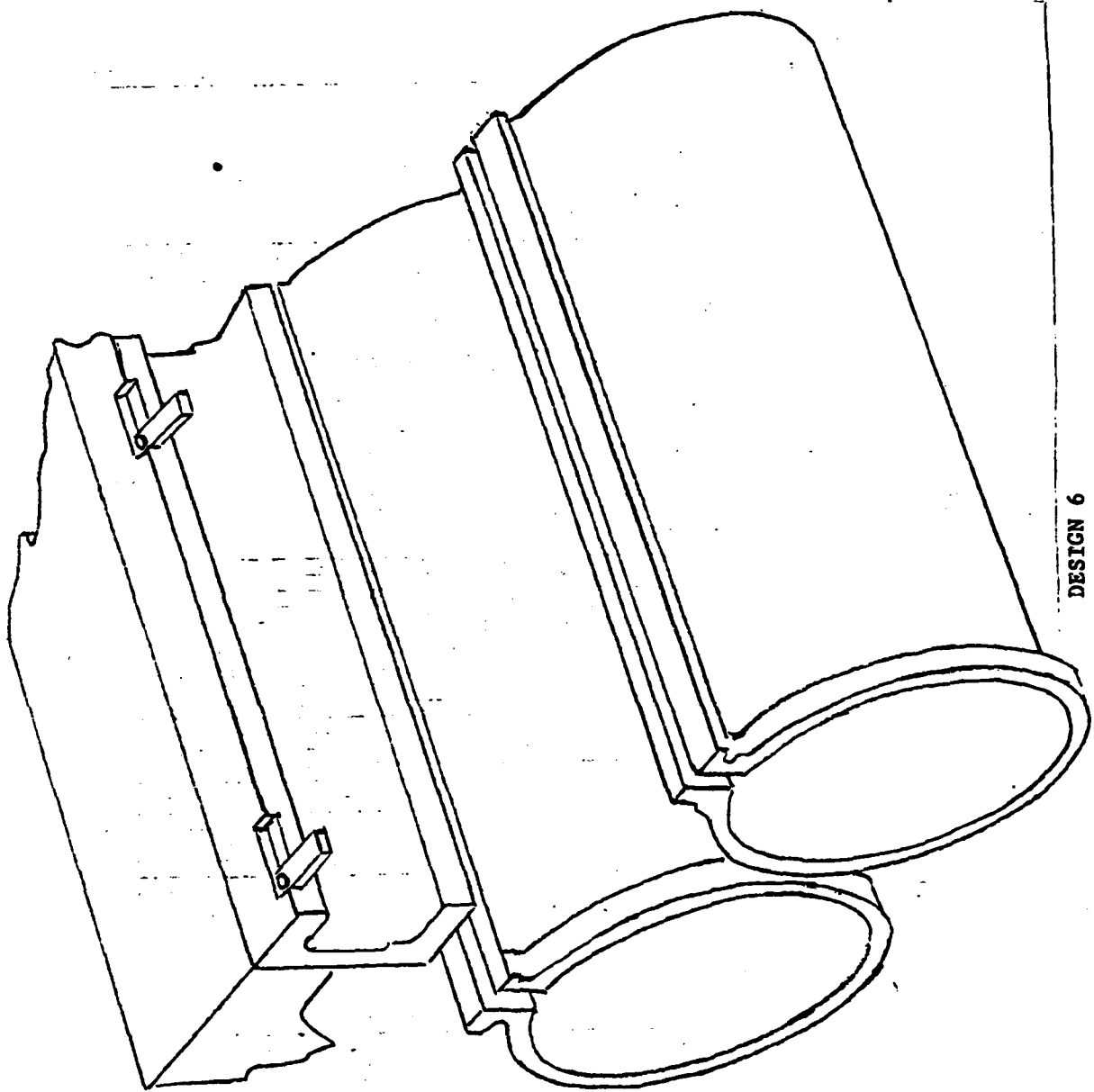

DESIGN 6
FIGURE A-6

APPENDIX A — ALTERNATE DESIGN PROPOSALS (CONTD)

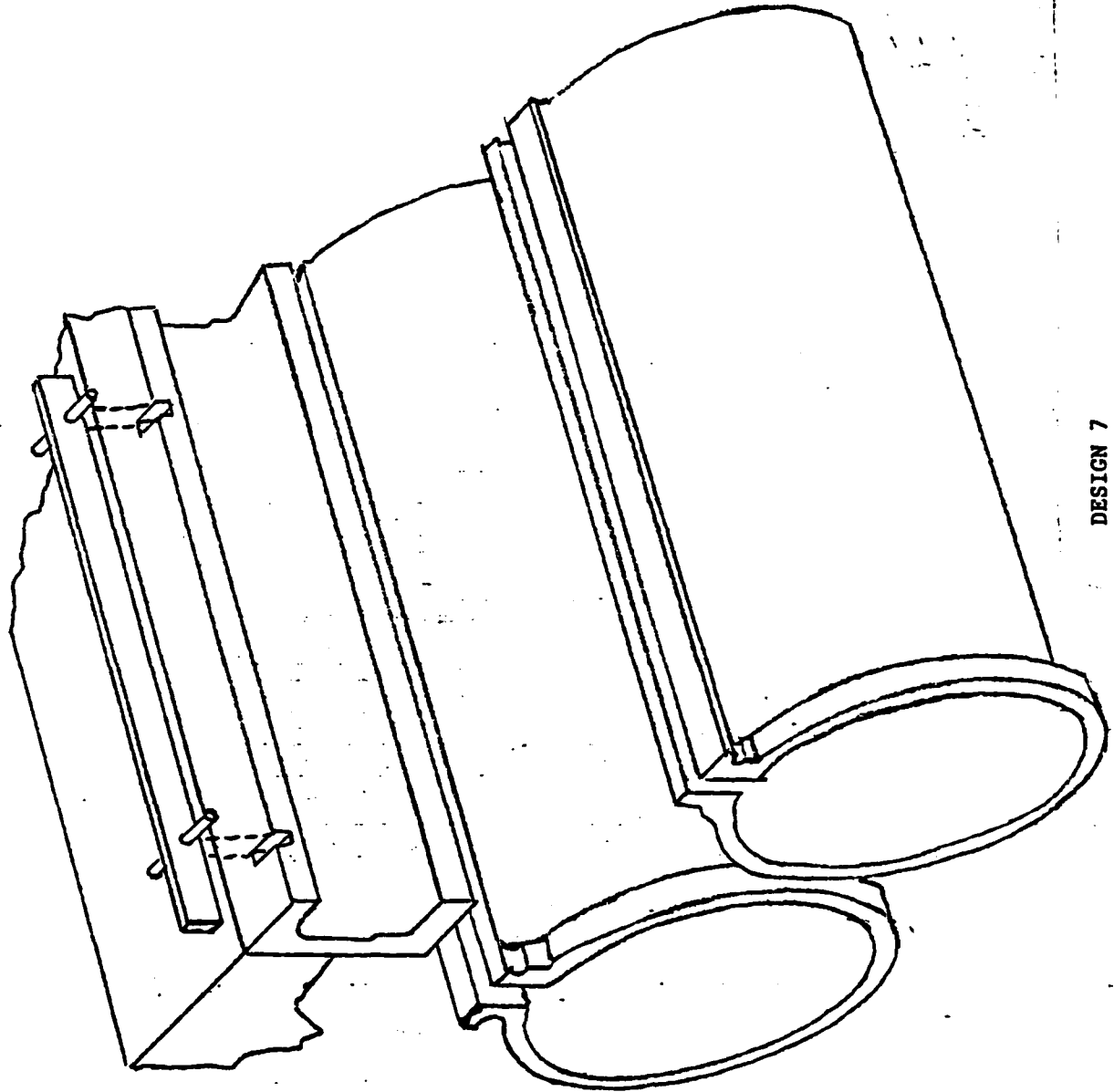

DESIGN 7
FIGURE A-7

APPENDIX A — ALTERNATE DESIGN PROPOSALS (CONTD)

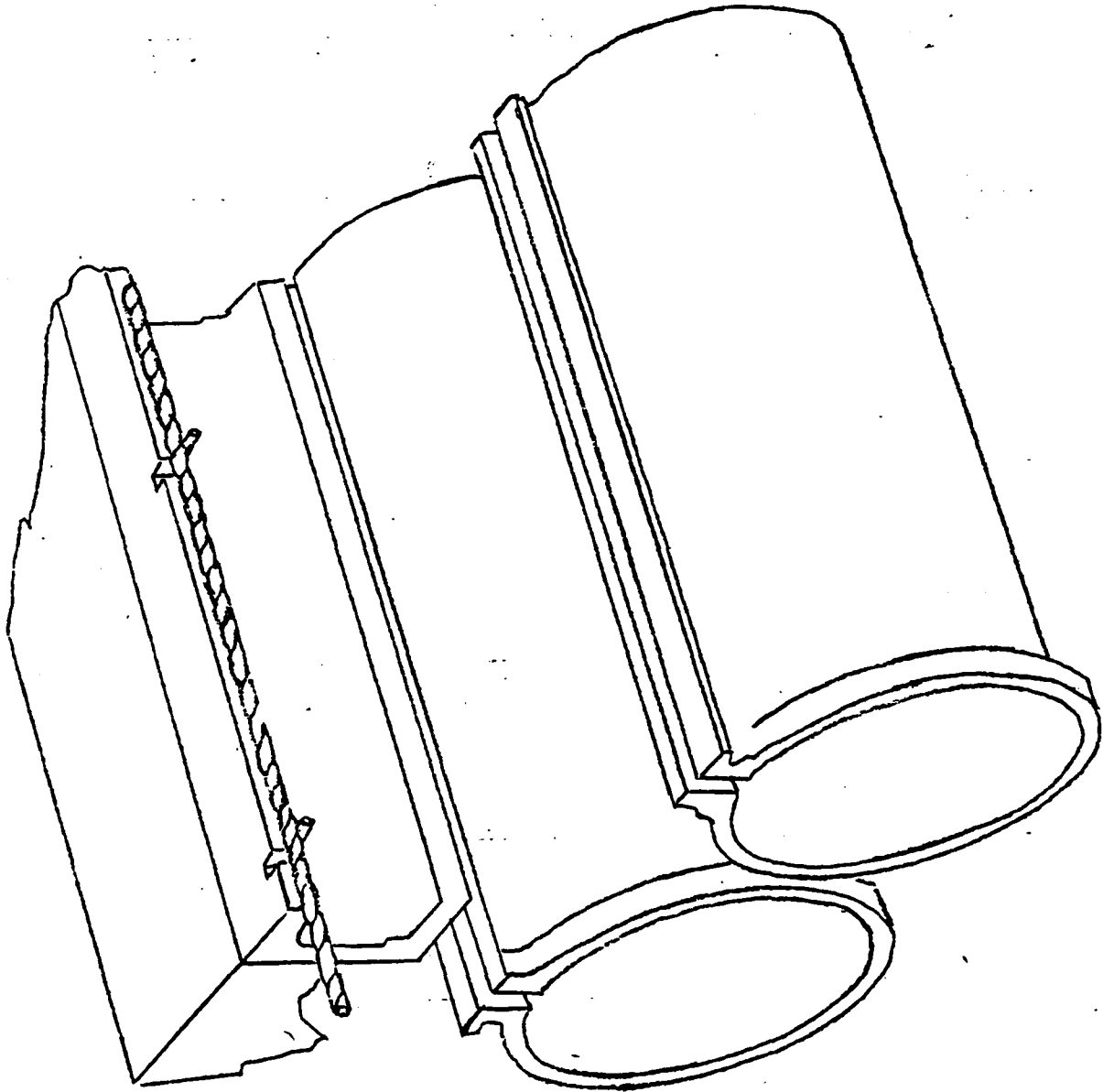

DESIGN 8
FIGURE A-8

APPENDIX A — ALTERNATE DESIGN PROPOSALS (CONTD)

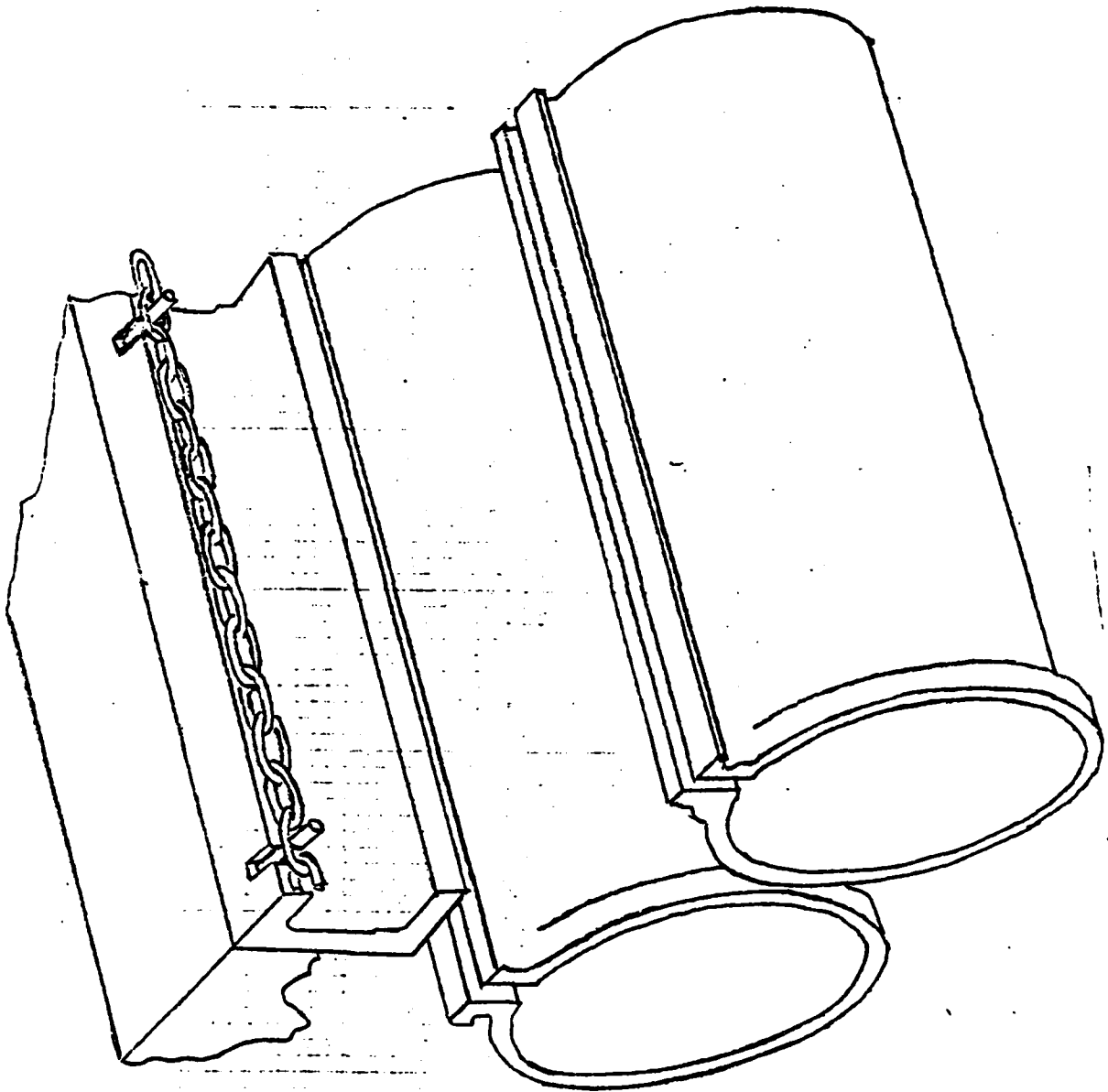

DESIGN 9

FIGURE A-9

APPENDIX A — ALTERNATE DESIGN PROPOSALS (CONTD)

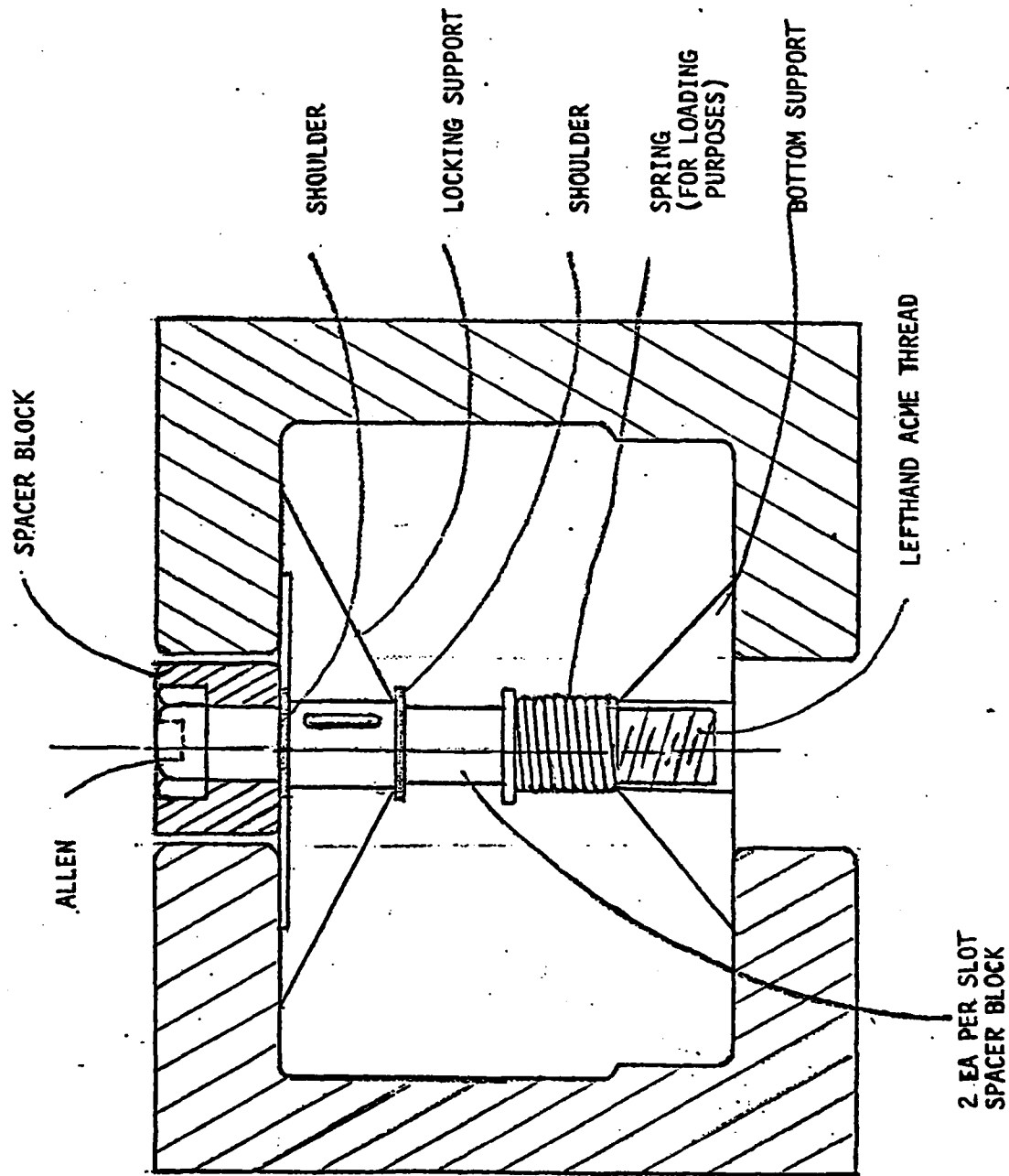

DESIGN 10
FIGURE A-10

APPENDIX B - EVALUATION OF ALTERNATE DESIGN PROPOSALS

1. DESCRIPTION OF "EMPHASIS CURVE TECHNIQUE"

a. The evaluation of several proposed schemes to correct a design deficiency by a comparison study which includes many different factors results in a complex decision making problem.

b. An analytical technique known as the "Emphasis Curve" was used to help simplify the problem. The technique emphasizes the more important parameters to be considered in selecting the optimum design, while de-emphasizing the less important ones. The procedure does not substitute for the judgment of the evaluator, it merely helps him to systematize the decision-making process by keeping account of all parameters, and by determining the importance of each relative to all the others. In this way, each parameter can be weighted in proportion to its importance. These weighting factors called RIF (Relative Importance Factors) are assigned to the parameters through analysis.

c. After determining the importance of each parameter to be used in the evaluation, every design is assigned a numerical score for each parameter. This score is proportional to the degree in which the particular engaging system satisfies the requirements of the parameter.

d. Multiplying the score by the weighting factor assigned for that parameter generates a table of effective scores for each design proposal and each parameter. The effective scores for every design proposal are totalled, and the design scoring the highest is the optimum one.

2. TRADE-OFF STUDY

a. Seventeen parameters were chosen for the evaluation. These are listed in Table B-2 in their final order of rank. Four additional parameters used to rate the slot/crossdeck pendant modifications in the extended study are also shown in Table B-3.

b. Table B-1 is a worksheet which illustrates the operation of the Emphasis Curve Technique. The parameters to be used in the comparison study are first listed in any order, and identified by letter in this table. Each parameter is then compared with every other parameter on a one-for-one basis. The evaluator determines which of the two parameters is the more important, and identifies the one chosen by circling the identifying letter on the worksheet. When every one of these individual comparisons is made, the number of times each parameter is circled is totalled. The parameter scoring the highest is the most important, the lowest score being the least important. The

APPENDIX B - EVALUATION OF ALTERNATE DESIGN PROPOSALS (CONTD)

individual parameter scores are called Relative Importance Factors.

c. The various design proposals are now assigned a score for each parameter based on how well they satisfy the requirements of the parameter. The scoring system is shown in Table B-2. The trade-off study is completed by multiplying the score assigned to each parameter by its RIF and totalling these products for each proposal. For example:

PARAMETER	RIF	DESIGN 1		DESIGN 2	
		SCORE	RIF X SCORE	SCORE	RIF X SCORE
Reliab/Tech Risk	15	1	15	3	45
Accident Potential if Not Removed Prior to Launch	14	1	14	1	14
	⋮	⋮	⋮	⋮	⋮
	⋮	⋮	⋮	⋮	⋮
	⋮	⋮	⋮	⋮	⋮
TOTAL			453		448

APPENDIX B - EVALUATION OF ALTERNATE DESIGN PROPOSALS

TABLE B-2 -- DESIGN EVALUATION PARAMETERS IN RANKED ORDER

	<u>RIF*</u>
Reliability/Tech Risk	15
Accident potential if not removed prior to launch	14
Probability of causing F.O.D.	13
Susceptibility to hook impact damage	11
Installation and removal time	11
Susceptibility to damage during retract	11
Catapult track modifications required	9
Susceptibility to jet blast and other damage	8
Shuttle modifications required	7
Service life expectancy	7
Maintenance requirements	6
Life cycle cost	6
Procurement cost/design complexity	6
Number of personnel required	5
Development time	3
Stowage problems	3
Special tools required	2

* Relative importance factor

Scoring System

<u>Score</u>	
0	Does not meet minimum requirement
1	May meet minimum requirement
2	Meets minimum requirement
3	Meets more than minimum requirement
4	Generally satisfies all criteria
5	Meets criteria in all respects
6	Optimum solution

APPENDIX B - EVALUATION OF ALTERNATE DESIGN PROPOSALS (CONTD)

TABLE B-3 -- ADDITIONAL PARAMETERS FOR EVALUATION OF SLOT/CDP MODIFICATIONS

	RIF
Recovery Performance Penalty	20
Hook Point Changes Required	20
Shuttle Fatigue Life Degradation	15
Catapult Operational Impact	10

TABLE B-4 -- AVERAGE SCORES FOR THE TOP 5 PROPOSALS

NO.	PROPOSAL	AVERAGE SCORE
1	Buttons (PN 519282)	508
2	Swing Bars (Design 6, Fig A-6)	493
3	Tandem Stanchion (Design 2, Fig A-2)	477
4	Slot/CDP Mod 2 (Table 1)	461
5	Single Stanchion (Design 1, Fig A-1)	456

APPENDIX C - RECOVERY SYSTEM PERFORMANCE AS A FUNCTION OF CDP SIZE

A. ESTIMATION OF RECOVERY PERFORMANCE PENALTIES AS A FUNCTION OF CDP SIZE.

Assumptions:

1. No additional energy is absorbed due to increased dynamic cable tension peaks and the hydraulic tension pattern is unaffected.
2. Sheave impact and anchor reflection peak tensions in the dynamic range are modulated such that their amplitudes are reduced in proportion to their time of occurrence as follows:

DYN. PEAK	TIME AFTER* ENGAGEMENT	% REDUCTION FROM T1
T1, Initial Impact	0	0
T2, Sheave Impact	.16 sec	$\frac{.16}{.50} = 32\%$
T3, Anchor Reflection	.30 sec	$\frac{.30}{.50} = 60\%$
T4, Hydraulic Peak	.50 sec	100 %

* From typical high energy Mark 7 Mod 2 aircraft engagements.

3. Hookloads and decelerations increase in proportion to cable tension.

Effect of CDP mass on initial impact tension, T_1 from reference (c).

$$\frac{T_1}{AE} = .63 \left(\frac{V_0}{c} \right)^{4/3} \quad (1)$$

Where: A = Cross-sectional area or metallic area, ft^2

E = Modulus of elasticity, ft^2

V_0 = Engaging velocity, fps

c = Speed of tension wave propagation, fps

$$= \sqrt{\frac{E}{\rho}} \quad \text{where} \quad \rho = \text{mass density, } \frac{\text{#sec}^2}{\text{ft}^4}$$

Ref: (c) NAEF-ENG-6169, Cable Dynamics, F. O. Ringleb, 27 Dec 1956

APPENDIX C - RECOVERY SYSTEM PERFORMANCE AS A FUNCTION OF CDP

For 6 x 30 Type G Flattened Strand Wire Rope:

NOMINAL DIA (IN)	WT/FT (LB)	METALLIC AREA (IN ² /FT ²)	DENSITY (LB/FT ³)	MASS DENSITY (LB SEC ² /FT ⁴)	MOD OF ELASTICITY (LB/FT ²)
1-3/8	3.40	.898/.00624	547	16.97	209 x 10 ⁸
1-1/2	4.05	1.069/.00742	↓	↓	↓
1-5/8	4.75	1.254/.00871	↓	↓	↓
1-3/4	5.51	1.455/.0101	↓	↓	↓

From this data and Eq (1), Figure C-1 was plotted. Figure C-2 was then constructed to depict the effect of cable size on peak dynamic tension (generally the sheave impact tension, T_2) in accordance with 2 above. Dynamic cable tensions for the standard 1-3/8 inch CDP were plotted from the curve fit developed for the Mark 7 Mod 3 in reference (d). This is applicable to the Mod 2 as well, because the dynamic tension peaks are substantially independent of the energy absorbing unit given that the deck geometry is the same.

The curve fit determined from Mark 14 aircraft tests in reference (e), is also shown for comparison with the computed 1-1/2 inch diameter curve (the Mark 14 is the only source of 1-1/2 inch CDP test data). The computed curve is seen to be conservative, that is, it overpredicts tension peaks by about 10 percent. It may be assumed that the 1-5/8 inch computed curve is also conservative to the same degree, and both these curves represent a worst case analysis.

No estimate for the 1-3/4 inch CDP is shown, because that option would impose unacceptably low engaging velocity limits and would require hook point modifications as well.

To determine permissible engaging velocities with the larger cables, a representative group of aircraft likely to generate cable tension peaks in the dynamic range was considered with results illustrated in the table on the following page.

Ref: (d) NAEL-ENG-7511, Performance Analysis of Mark 7 Mod 3 Recovery System Based on Aircraft Calibration Tests, J. H. Zurzolo, 1 Aug 1969

(e) NAEC-ENG-7886, Mark 14 Aircraft Arresting System Performance Analysis Based on Aircraft Test, R. Barron, 21 May 1976

APPENDIX C - RECOVERY SYSTEM PERFORMANCE AS A FUNCTION OF CDP SIZE (CONTO)

A/C	MAX WT (LB)	CURRENT MK 7 MOD 2 ENGAGING VEL LIMITS (KNS)	PREDICTED ENGAGING VELOCITY LIMITS WITH LARGER CDPS (FROM FIG 2) (KNS)	
			1-1/2 IN	1-5/8 IN
F-4J	40,000	126 (AG) ¹	126 ¹	120
A-4	14,500	125 (G)	114	104
A-7E	26,200	134 (AG)	122	111
A-6E	36,000	104 (LG)	104	104

Where AG = Arresting Gear capacity limited.
 G = Deceleration limited.
 LG = Landing Gear strength limited.
 1 = This is a "hydraulic" peak.

Those aircraft incurring an engaging speed penalty as a result of the larger CDPS are included in Table 1 with the estimated performance limitation.

B. ESTIMATION OF SAFETY FACTOR AND LIFE EXPECTANCY FOR SHUTTLE MODIFICATIONS.

Options No. 2 and No. 3 require reducing the thickness of the shuttle frame in Figure C-3 by 1/8 inch and 1/4 inch respectively.

The shuttle loads and factors of safety are summarized in Table 1 for the full width shuttle and the two modifications.

APPENDIX C — RECOVERY SYSTEM PERFORMANCE AS A FUNCTION OF CDP SIZE (CONTD)

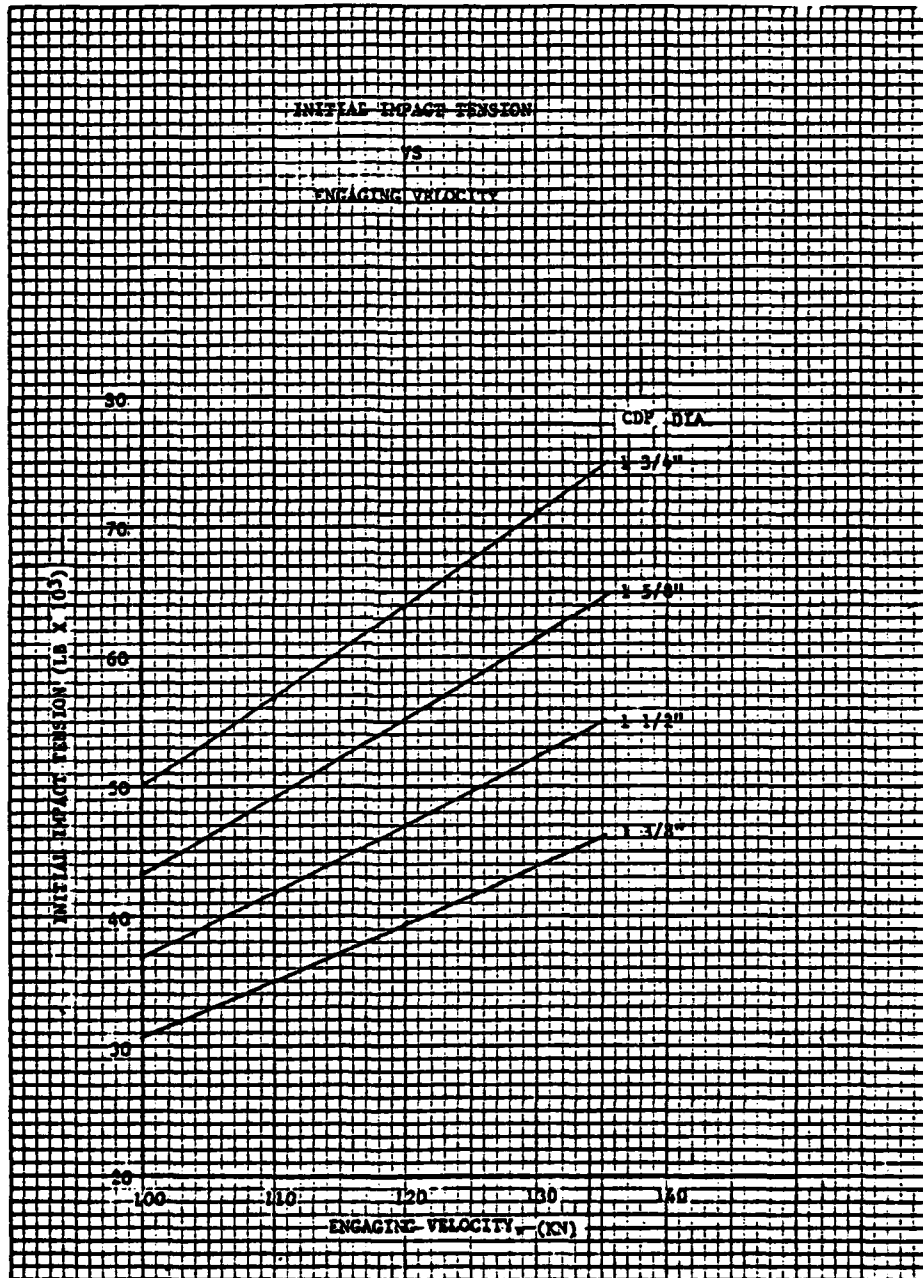

FIGURE C-1

44 (C-4)

APPENDIX C — RECOVERY SYSTEM PERFORMANCE AS A FUNCTION OF CDP SIZE (CONTD)

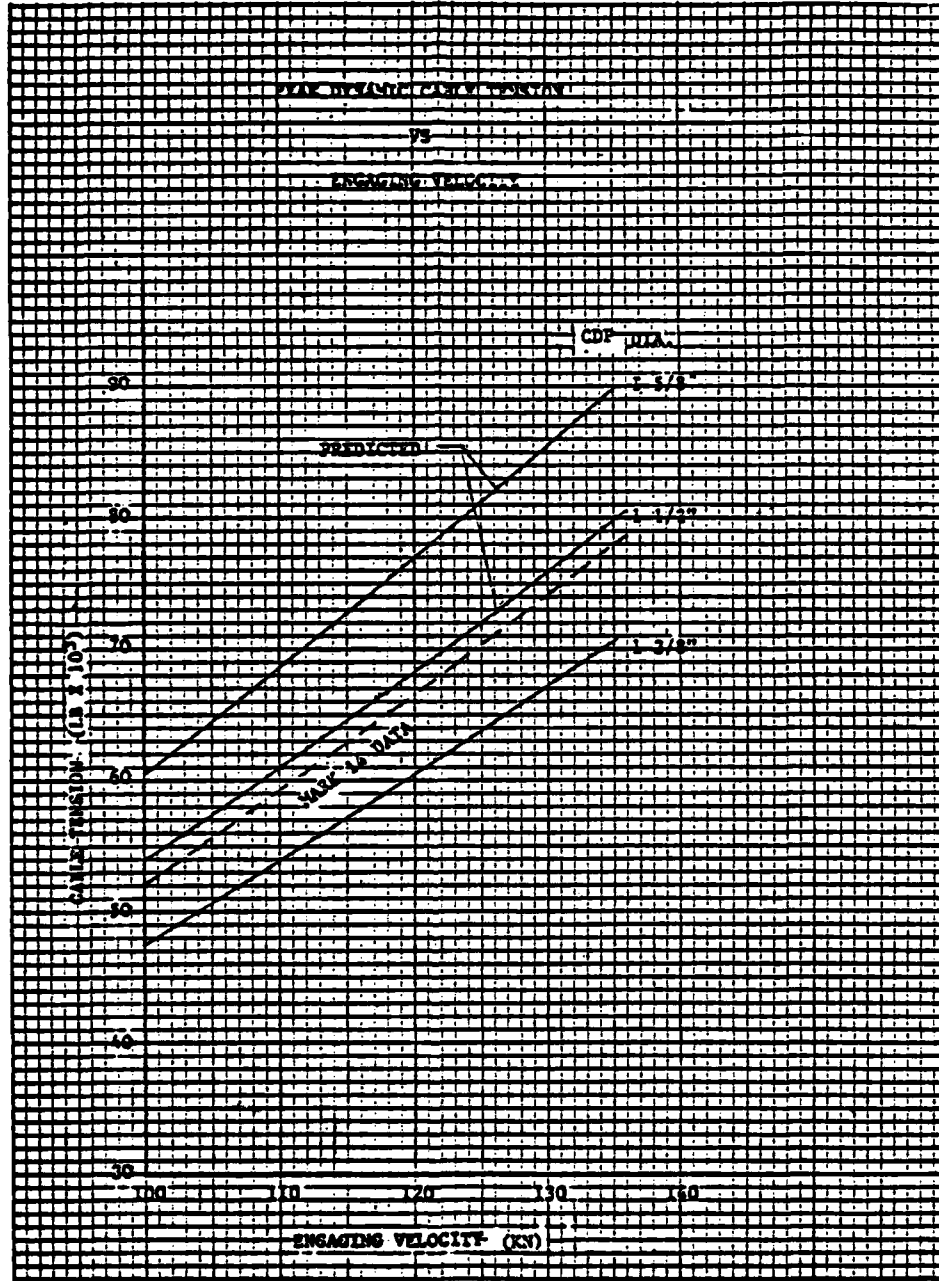

FIGURE C-2
45/46 (C-5/C-6)

APPENDIX D - TRIP REPORTS TO USS KITTY HAWK (CV 63) AND USS JOHN F. KENNEDY (CV 67)

9422:WFW:jd
21 December 1978

MEMORANDUM

From: 9422 (W. Wismar)

To: 91216

Via: 9422, 942, 94, 94A

Subj: Report of trip to the USS Kitty Hawk, CV-63, to install buttons in the No. 3 catapult deck slot

1. Thirty buttons, 519282-2, ten installation tools, and three button carts, 519283-1 were shipped to U. S. Naval Air Station, North Island, CA. These were loaded aboard and statically tested on the USS Kitty Hawk during the period 1 December 1978 to 7 December 1978. Only 12 buttons were installed during these dockside tests. The shuttle was stowed in the battery position with the cover installed. The first button was positioned approximately 15 feet forward of the shuttle and each subsequent button was installed at 12 foot intervals, the length of two cover plates. When the number 4 arresting gear was pulled out, approximately 45 feet of deck pendant extended beyond the last installed button. The potential for the number 4 pendant falling in the slot existed with the installation. Optimum spacing will be determined during actual aircraft landing operations.
2. The ship's arresting gear personnel were made responsible for handling the buttons, thus they were apprised of installation and removal procedures. Four men, 2 per six button cart, proceeded from behind the starboard foul line after the simulated last waist catapult launch. One crew installed the 12th through 7th buttons while the second crew installed the 6th through 1st buttons. Installation times were 2 minutes - 1st attempt and 1-1/2 minutes - 2nd attempt. This was judged to be fully satisfactory since it would not hinder recovery operations. The buttons were favorably received by the ship's crew since they appeared to be an outgrowth of the crude devices they had manufactured and used for about a month.
3. The crew's comments were primarily directed at the carts and installation tool. They felt the cart was too short, that one which held two more buttons would be about right. Also an additional cart lug to hold a pit-pin failed within 10 minutes use. They also would appreciate a cart designed to allow button slide out when the cart was laid down. They felt the installation tool was flimsy and cumbersome to use. They would prefer a speed wrench with an allen wrench driver. This would necessitate installing cap screws in the buttons.
4. Three retractions of the number 4 arresting engine were conducted while the twelve buttons were installed. The port purchase cable terminal was placed between the raised Van Zelm tracks and approximately 50 feet of purchase cable and 10 feet of deck pendant were stuffed into the number 3 catapult slot prior to the retractions. In each case during the retraction

NAEC-91-7964

APPENDIX D - TRIP REPORTS TO USS KITTY HAWK (CV 63) AND USS JOHN F. KENNEDY (CV 67)
(CONTD)

9422:WFW:jd
21 December 1978

MEMORANDUM

Subj: Report of Trip to the USS Kitty Hawk, CV-63, to install buttons in the
No. 3 catapult deck slot

the buttons forced the cable out of the slot and kept it out. It was felt
that data collected at sea is the only way to properly evaluate button position
optimization to preclude cable damage.

W. F. WISMAR

Copy to:
91223
91224
91221
91232
9121

APPENDIX D - TRIP REPORTS TO USS KITTY HAWK (CV 63) AND USS JOHN F. KENNEDY (CV 67)
(CONTD)

Report of trip to USS John F. Kennedy, to install buttons, excerpt from TPR 79-2

19 Jan 1979

DISCUSSION

1. A recent cross deck pendant failure, on the No. 4 arresting engine of the USS JOHN F. KENNEDY (CV67), during night operations, resulted in the loss of an F-14A aircraft, BUNO 159012. Investigations to date suggest that the failed deck pendant had been severely damaged before the last engagement as a result of having fallen into the No. 3 catapult track slot. The results of these investigations are presented in reference (a).

2. Aircraft recovery operations were observed aboard the CV67 between 16 and 18 April 1978. The frequency with which the purchase cable and cross-deck pendant entered the No. 3 catapult track slot was recorded and is included as enclosure (1).

3. Various devices to keep the crossdeck pendant out of the catapult track slot were designed, fabricated, and tested at the Naval Air Engineering Center, Lakehurst, New Jersey (a separate Task Progress Report will be prepared covering the individual devices). The best device as of October 1978, a track-slot button, PN 519282-1, was selected for test aboard the USS JOHN F. KENNEDY (CV67).

4. Thirty of the track-slot buttons were manufactured for use aboard the ship. The shipboard buttons differed from the prototype buttons tested at Lakehurst in two respects; first the locking tangs which were an integral part of the prototype button were manufactured separately and secured to the shipboard button with 100-degree countersunk allen head machine screws; the second difference was the shipboard buttons were cadmium plated, whereas the prototype buttons had not been plated.

5. Carts to transport the buttons were designed; however, they were not manufactured in time for use in the shipboard tests. A substitute cart was fabricated by the ships crew. The cart was made from a metal container approximately 15-inches wide, 24-inches long, and 12-inches high. Wheels and a handle were added to the container.

6. While the ship was at anchor the procedures for track-slot button installation, removal, and inspection were explained to the crew. The waist catapult deck crew was selected to install and remove the buttons. Installation and removal drills were conducted to determine shipboard operating procedures, number of people required, time requirements, and to familiarize the crew. The procedures developed during these drills and the tests during operations, were used to develop a set of instructions for use of the buttons. These instructions are included as enclosure (2).

APPENDIX D - TRIP REPORTS TO USS KITTY HAWK (CV 63) AND USS JOHN F. KENNEDY (CV 67)
(CONTD)

7. It was found that the lock/lift tool could pass through the catapult track slot, even with the 2-inch washer in place. During installation drills it was observed that the crew frequently did not fully tighten the latch bolts. This was caused by a fear that they would break the lock/lift tool. After several demonstrations of the proper tightening technique this problem was reduced.

8. It was found that up to 18 buttons could be installed within two minutes and twenty seconds, repeatedly. The technique developed required 3 men. The first man pulls the button container, the second man removes the buttons from the container and places them in or near the track slot at the proper location, and the third man sets the latches and tightens the locks. When all the buttons have been placed in the slot, the second man begins to set the button latches and tightens the locks working from the opposite end of the catapult from the third man. The first man then stores the button container in the port catwalk and assists the second man in setting the button latches and tightening the locks. The first and second man each tighten alternate buttons working from zero station forward. When all button latches are set and tightened the three men leave the flight deck and store the lock/lift tools in the button container.

9. During the at-sea period, the track slot buttons were used during aircraft recovery operations. Data collected during this period is presented in enclosure (3). Figure 1 shows the relative position of the buttons for the configurations tested.

10. The first tests were conducted using 12 buttons. The Shuttle was positioned 18 feet from Station zero and the cover, PN 616532-1, installed. The first button was located 50-feet forward from Station zero with the remaining buttons installed at 12-foot intervals. The configuration was a definite improvement over no buttons, however, the cable still fell in the slot behind the first button. Also, if the cable was laying in the slot prior to the start of the retract, it tended to remain in the slot during the entire retract. The 12-foot spacing was easy to maintain because it represents an interval of two deck plates. The deck plate seems to provide a good reference point for the crew to maintain the spacing during installation.

11. The incidence of cables falling in behind the first button was reduced by adding a thirteenth button, and installing the first button 33-feet versus 50-feet forward from Station zero. If the cable was in the slot prior to the start of retraction it still tended to stay in the slot riding over the button and falling back in the slot behind the button.

12. Four additional buttons were added and the spacing was varied. Ten buttons were installed at 12-foot intervals starting from Station 27. The remaining seven buttons were installed at 6-foot intervals so that the final button was at Station 183. It was observed that if the cable fell in the slot prior to the start of retraction, in the area where the buttons were spaced at 6-foot intervals, it would be removed from the slot by the buttons at the start of retraction and remain out during the entire retraction.

19 Jan 1979

APPENDIX D - TRIP REPORTS TO USS KITTY HAWK (CV63) AND USS JOHN F. KENNEDY (CV 67)
(CONTD)

CONCLUSIONS

1. The buttons tested aboard ship were different from the prototypes tested at Lakehurst. While the differences were not major, one change resulted in a minor failure.
2. The lock/lift tool can fall into the catapult track slot.
3. Button latch bolts are not always properly tightened during installation.
4. Changing the design of the button would reduce the chance of the button coming out of the slot when impacted by a tail hook, and reduce the probability of damage caused by impact with a terminal.
5. Eighteen buttons can be installed in two minutes and twenty seconds by three men.
6. Buttons must be installed back to Station zero to prevent the cable from entering the catapult track slot behind the buttons.
7. Buttons installed at six foot intervals will remove the cable from the slot at the start of retraction.
8. The eighteen button configuration provided the best results of those tested and significantly reduced the incidence of the crossdeck pendant falling into the number three catapult track slot.
9. The installation of more than 18 buttons would increase the cycle time between launch and recovery operations.
10. The procedures for use of the buttons, enclosure (2), provide satisfactory instructions for installation, removal, storage, and maintenance of buttons.

RECOMMENDATIONS

1. The diameter of the washer on the lock/lift tool should be increased to eliminate the possibility of the tool falling into the catapult track slot.
2. The 18-button configuration should be used aboard the CV67, USS JOHN F. KENNEDY.
3. The crossdeck pendant should be inspect if it is retracted in the catapult track slot for a distance greater than the spacing between two buttons.
4. If the crossdeck pendant falls into the catapult track slot forward of the buttons it should be removed by the hookrunner, prior to retracting.
5. The button shape should be modified to blend the top section in with that portion that extends below the deck. This would reduce the chance of nicks being caused by impact with the terminal.

NAEC-91-7964

APPENDIX D - TRIP REPORTS TO USS KITTY HAWK (CV 63) AND USS JOHN F. KENNEDY (CV 67)
(CONTD)

19 Jan 1979

RECOMMENDATIONS (Con't)

6. The button should be modified to provide a recess for the locking bar to fit in, when in the locked position. This would keep the button from coming out of the catapult slot if impacted by an aircraft tail hook, even if the lock is only partially tightened. The recessed lock button should be manufactured and tested in both double and single lock configuration. If the single lock style is successful it would reduce both cost and installation time.
7. Spare parts should be provided to allow minor in-service repairs to be performed.
8. A cart should be provided for the CV67. The cart should permit rapid counting of the buttons.
9. The buttons should be inspected when the CV67 returns from its current deployment.
10. The screw that secures the locking tang should be replaced with a stronger one to avoid repetition of the failure that occurred during ship-board tests.
11. The procedures for use of the buttons, enclosure (2) should be adopted.

REFERENCE

- (a) NAEC Preliminary Report No. 91-1.

FIGURE

Figure 1 - Track Slot Button Layouts.

APPENDIX D - TRIP REPORTS TO USS KITTY HAWK (CV 63) AND USS JOHN F. KENNEDY (CV 67)
(CONTD)

31 Jan 1979

Report of trip to USS KITTY HAWK to install buttons, excerpt from TPR 79-4

DISCUSSION

1. A recent crossdeck pendant failure aboard the USS KENNEDY (CV67) resulted in the loss of an F-14A aircraft. Investigation indicated that the failed deck pendant had been severely damaged as a result of having fallen into the No. 3 catapult track slot. Various devices to keep the crossdeck pendant out of the catapult track slot have been developed. The best device to date, a track slot button, PN 519282-1, was tested aboard the USS KENNEDY (CV67) and reported in reference (a).

2. Additional tests have been conducted aboard the USS KITTY HAWK (CV63). Twelve buttons were installed and statically tested at dockside between 1 December 1978 to 7 December 1978. Results of these tests are reported in reference (b).

3. Aircraft recovery operations were observed aboard the CV63 between 11 January 1979 and 16 January 1979. A six and twelve button configuration was utilized during this period. The six button configuration was as follows: The shuttle was stored at Station Zero, the first button was installed at Station 14, and the succeeding buttons were installed 24-feet apart, with the last button located at Station 146. The twelve button configuration was as follows: The shuttle was stored at Station Zero, the first button was at Station 14, and each succeeding button was 12-feet apart, the last at Station 146. Data collected during this period is presented in enclosure (1).

4. During tests with six buttons installed the crossdeck pendant fell into the track slot four times in the thirty-three retractions observed. Inspection showed no crossdeck pendant damage. Although the crossdeck pendant was immediately ejected by the buttons, the six button configuration was found inadequate due to the frequency of the cable falling into the catapult track slot.

5. During tests with twelve buttons installed the crossdeck pendant fell into the track slot six times in the 317-retractions observed. During five of the six incidents the crossdeck pendant was immediately ejected by the next button during retraction. During the sixth incident, the crossdeck pendant fell into the track slot in front of the twelfth button during retraction and rode over each button, falling back into the track slot during the entire retract. This crossdeck pendant was inspected and found to be satisfactory for continued service use. However, it was removed because it sustained 85 arrestments. This pendant is to be returned to NAEC for a more detailed inspection.

NAEC-91-7964

APPENDIX D - TRIP REPORTS TO USS KITTY HAWK (CV 63) AND USS JOHN F. KENNEDY (CV 67)
(CONTD)

31 Jan 1979

6. During the at-sea period, fifty-one bolters occurred with no incident of a tail hook impacting any buttons. During this period 519 arrestments were conducted. The buttons were inspected prior to the start of each days operations, and no damage was noted. The purchase cable did not fall into the track slot with the buttons installed.

7. During the at-sea period, button installation and removal times were observed. The time for four men, 2 per six button cart, to install the twelve buttons varied between one minute 20 seconds and one minute 40 seconds.

8. The main complaint from ship personnel was the design of the button cart. It was felt that, (1) the cart handle should be longer, (2) the wire ring that held the cart pip-pin was weak and could easily fail, (3) two tool holders should be provided per cart to hold a second installation tool, and (4) the installation tool should be replaced with a speed wrench having an allen wrench driver of a size similar to that used for other catapult/arresting gear hardware. It was also observed that the crew preferred to carry the carts (empty or full) rather than wheel it across the deck. This can be attributed to the short cart handles.

9. The track slot widths were measured and found to be well above the minimum width of 1.40 inches. This condition contributed to the crossdeck pendant coming out of the track slot easily and without damage during retractions. The track slot widths at each button location (beginning aft to forward) were as follows:

<u>Location Button No.</u>	<u>Track Slot Width (Inches)</u>
1	1.702
2	1.745
3	1.716
4	1.746
5	1.725
6	1.689
7	1.698
8	1.846, 1.858, 1.813*
9	1.689
10	1.694
11	1.695
12	1.674

*Three readings taken at one foot intervals due to the large readings.

APPENDIX D - TRIP REPORTS TO USS KITTY HAWK (CV 63) AND USS JOHN F. KENNEDY (CV 67)
(CONTD)

31 Jan 1979

10. In order to gain some insight as to the number of times the purchase cable or crossdeck pendant fell into the track slot without buttons installed, the ship's arresting gear logs, covering operations during October and November 1978, were examined. During this period, 1,376 arrestments were conducted and the cable fell into the track slot 82 times. When compared to operations using the twelve button configuration, where 6 incidents occurred in 519 arrestments, it is clear that the buttons have greatly reduced the number of times and severity of damage to the cable falling into the track slot.

11. The ships reaction to the buttons was favorable. Their primary concern is the possibility of a button being inadvertently left in the track slot during catapult operations. They would prefer to work with an automatic system or a single piece of hardware to reduce handling by ship's personnel.

NAEC-91-7964

APPENDIX D - TRIP REPORTS TO USS KITTY HAWK (CV 63) AND USS JOHN F. KENNEDY (CV 67)
(CONTD)

31 Jan 1979

CONCLUSIONS

1. The six-button configuration was found to be inadequate.
2. The twelve button configuration greatly reduced the number of incidents and severity of damage to the cable falling into the track slot.
3. The possibility exists of a button being inadvertently left in the track slot during catapult operations.
4. Twelve buttons can be installed in one minute forty seconds by four men.

RECOMMENDATIONS

1. The twelve button configuraton should be used aboard the CV63.
2. Redesign the button cart to make it easier for personnel to handle.
3. A system to keep the cable out of the track slot which would require a minimum of handling by ships personnel should be designed.
4. The crossdeck pendant should be inspected if it is retracted in the track slot for a distance greater than the spacing between two buttons.
5. Conduct tests at Test Department catapult site to determine possible shuttle damage with track slot button installed.

REFERENCES

- (a) TPR NO. 79-2.
- (b) Memo 9422:WFW:jd of 21 Dec 1978.

ENCLOSURE

- (1) Data Sheets.

**DATE
FILMED**

