

LEVEL

20

Sparton 7723-A003(F)

AD A108389

MODIFIED AMBIENT SEA NOISE INDICATOR
WITH
AMBIENT NOISE DIRECTIONALITY ESTIMATOR
Final Technical Report

30 October 1981

Contract N62269-81-C-0306

Prepared For

Naval Air Development Center
Warminster, Pennsylvania 18974

Prepared By

William Ezell

SPARTON ELECTRONICS
Division of Sparton Corporation
Jackson, Michigan 49202

DTIC
ELECTE
S DEC 10 1981 D
D

Submitted in accordance with the requirements of
sequence A003 of DD 1423 of subject contract.

FILE COPY

DISTRIBUTION STATEMENT A
 Approved for public release
 Distribution Unlimited

81 11 02 148

| | |
|----------------------------|-------------------------------------|
| Accession For | |
| NTIS GRA&I | <input checked="" type="checkbox"/> |
| DTIC TAB | <input type="checkbox"/> |
| Unannounced | <input type="checkbox"/> |
| Justification | |
| By <i>Per Ltr. on file</i> | |
| Distribution/ | |
| Availability Codes | |
| Dist | Avail and/or Special |
| A | |

Sparton-7723-A003(F)

MODIFIED AMBIENT SEA NOISE INDICATOR
 WITH
 AMBIENT NOISE DIRECTIONALITY ESTIMATOR
 Final Technical Report

30 October 1981

Contract N62269-81-C-0306

Prepared For

Naval Air Development Center
 Warminster, Pennsylvania 18974

Prepared By

William Ezell

SPARTON ELECTRONICS
 Division of Sparton Corporation
 Jackson, Michigan 49202

Submitted in accordance with the requirements of
 sequence A003 of DD 1423 of subject contract.

**DTIC
 ELECTE
 DEC 10 1981**
S D
D

DISTRIBUTION STATEMENT A
 Approved for public release;
 Distribution Unlimited

CONTENTS

| <u>Section</u> | | <u>Page</u> |
|----------------|--|-------------|
| 1 | INTRODUCTION AND SUMMARY | 1-1 |
| 2 | ASNI/ANODE DESIGN CONCEPT | 2-1 |
| 3 | DESIGN CONSIDERATIONS | 3-1 |
| 3.1 | Electrical Design | 3-1 |
| 3.1.1 | Input Stage | 3-1 |
| 3.1.2 | Prefilters | 3-3 |
| 3.1.3 | Phase-Lock Loop | 3-3 |
| 3.1.4 | Demodulation and Directional Amplitude Information Recovery | 3-4 |
| 3.1.5 | Linear Amplifiers and Main Filters | 3-5 |
| 3.1.6 | AC-to-DC Converter | 3-6 |
| 3.1.7 | Mode Switch and Log Ratio Module | 3-7 |
| 3.1.8 | Synthesizer Board | 3-9 |
| 3.1.9 | Power Supply | 3-9 |
| 3.2 | Mechanical Design | 3-10 |
| 3.2.1 | External Configuration | 3-10 |
| 3.2.2 | ANODE/ASNI Function Switch | 3-10 |
| 3.2.3 | Panel Meter | 3-13 |
| 3.2.4 | Internal Redesign | 3-13 |
| 4 | DESIGN REVIEW | 4-1 |
| 5 | CONTRACTOR DEMONSTRATION TEST | 5-1 |
| 6 | CONCLUSIONS | 6-1 |
| Appendix | PRINTED-CIRCUIT BOARD ASSEMBLIES | A-1 |

ILLUSTRATIONS

| <u>Figure</u> | <u>Title</u> | <u>Page</u> |
|---------------|--|-------------|
| 3-1 | ID-1872/A MOD Block Diagram | 3-2 |
| 3-2 | System Bandwidth | 3-6 |
| 3-3 | Unmodified ID-1872/A ASNI | 3-11 |
| 3-4 | ID-1872/A MOD ASNI (with ANODE Modification) | 3-11 |
| 3-5 | ID-1872/A MOD External Dimensions | 3-12 |
| 3-6 | Unmodified ID-1872/A ASNI Internal Configuration | 3-14 |
| 3-7 | ID-1872/A MOD Internal Configuration | 3-14 |
| A-1 | Filter Board (A9) | A-2 |
| A-2 | Directional Information Recovery Board (A8) | A-3 |
| A-3 | AC-to-DC Converter and Log Ratio Board (A10) | A-4 |
| A-4 | Synthesizer Board (A7) | A-5 |

TABLES

| <u>Table</u> | <u>Title</u> | <u>Page</u> |
|--------------|--|-------------|
| 1-1 | Modified Ambient Sea Noise Indicator Characteristics | 1-2 |
| 3-1 | ANODE Voltage | 3-7 |
| 3-2 | ASNI Voltage | 3-8 |

SECTION 1
INTRODUCTION AND SUMMARY

The modified Ambient Sea Noise Indicator (ASNI) ID-1872/A MOD (table 1-1), which includes an Ambient Noise Directionality Estimator (ANODE) function, provides a comparison of the omnidirectional noise level and the summed noise levels of the two directional channels of a VLAD AN/SSQ-77 sonobuoy when in the ANODE mode. The omnidirectional ASNI absolute noise level can also be read for specific frequencies at the hydrophones of passive omnidirectional sonobuoys without automatic gain control when the modified unit is in the ASNI mode. Passive sonobuoys, located in the sea, will pick up sea noise with pressure-sensitive hydrophones. If the sonobuoy is an AN/SSQ-57, one omnidirectional hydrophone is used. If an AN/SSQ-77 sonobuoy is used, a vertical multielement array of hydrophones provides directional as well as omnidirectional information. The sea noise is transmitted to a receiver in the aircraft. The demodulated signal from the receiver is applied to the indicator. The ASNI and ANODE mode levels are indicated on the front panel meter, which is calibrated in decibels in a 1-Hz band relative to $1 \mu\text{Pa}^2$ for the omnidirectional noise level and in decibels for the directional channel to omnidirectional channel noise difference. The ambient sea noise levels may be used to plot a graph of ambient sea noise. The ANODE gain may be used to evaluate the effectiveness of the VLAD sonobuoy under various sea state conditions or at particular sea locations.

The Ambient Sea Noise Indicator was modified to include the ANODE function developed under contract N62269-81-C-0306. Work began 1 January and ended 31 August 1981. Sparton received two GFE Ambient Sea Noise Indicators, replaced all of the internal circuitry with newly designed circuit boards, and conducted design review and contractor demonstration tests to show compliance with performance requirements of the specification. Deliverable items included two modified units. Documentation consisted of monthly progress reports, monthly performance and cost reports, a test plan (not a contract item), a technical manual, and this final report.

Table 1-1. Modified Ambient Sea Noise Indicator
Characteristics

Size 5 3/4 inches × 8 3/16 inches × 8 1/16 inches
Weight 7 pounds
Power 9 volt-amperes

Electrical Features

| | |
|---------------------------|--|
| Analysis Bandwidth | 25 Hz |
| Analysis Center Frequency | 50, 100, 200, 440, 1000, 1700 Hz |
| Input Signal Source | ASNI AN/SSQ-57 ANODE AN/SSQ-77 |
| Input Signal | Receiver High Audio (Receiver standard audio with removal of internal jumper wire) |
| Maximum Signal | 90 kHz peak deviation > sea state 6 broadband noise |
| Dynamic Range | ASNI > 50 dB ANODE > 50 dB |

Operating Features

Internal power supply operates with 50-Hz to 440-Hz power source
Noninteracting ASNI and ANODE calibration
Ten-second integration time constant
High rejection of signals outside analysis bandwidth

SECTION 2
ASNI/ANODE DESIGN CONCEPT

The modified ID-1872/A consists of all new electronic circuitry within the original equipment case. In addition to the original ASNI function, the new circuits provide a method of comparing the AN/SSQ-77 DIFAR directional channels' sea noise level to the beamformed omnidirectional channel's sea noise level.

The comparison method consists of simultaneously demodulating, in phase quadrature, the DIFAR north-south and east-west directional channel information to two baseband signals, broadband phase shifting one of the baseband signals 90° relative to the other, and summing the signals. This resultant signal is the directional channel sea noise level.

The recovered directional channel amplitude information and the omnidirectional channel passband at specific sonar frequencies are next translated to zero frequency and analyzed by two precision linear multipliers and matched multipole low-pass filters. The low-pass filters provide equivalent bandwidths of 26 Hz centered at selectable synthesized frequencies of 50, 100, 200, 440, 1000, and 1700 Hz.

Two high-pass filters remove dc feedthrough as well as the zero beat terms with an effective bandwidth of 1 Hz. This results in an overall system analysis bandwidth of 25 Hz.

The filter outputs are converted to dc signals by two averaging rms-to-dc converters with 10-second integration time constants. These dc signals in turn undergo logarithmic ratio conversion, in which the logarithm of the directional channel is referenced to the logarithm of the omnidirectional channel amplitude. The resulting logarithmic ratio, displayed on the ANODE meter scale of 0 to 30 dB, indicates the difference in the effective received noise of a VLAD beamformed channel (omnidirectional) and the rms vector sum of the noise in the north-south and east-west directional channels. In general, the

higher the reading (in decibels), the greater the performance improvement attainable by use of the AN/SSQ-77.

The operator can choose between the ASNI and ANODE modes with a front panel toggle switch. The ASNI mode is calibrated for use with an AN/SSQ-57 sonobuoy. In the ASNI position, the absolute integrated omnidirectional ambient sea noise is routed to the logarithmic ratio module's signal input. The module's reference input voltage, compensated for 1-Hz sea noise equalization by the AN/SSQ-57 sonobuoy, is controlled by the front panel's rotary frequency selector. The logarithmic ratio module output is displayed on the ASNI meter scale, which is marked in decibels relative to $1 \mu\text{Pa}^2$ from 40 to 110 dB. This yields a repeatable indication of the actual sea noise relative to a 1-Hz bandwidth at all six analysis frequencies. The higher the reading in decibels, the greater the sea noise.

SECTION 3
DESIGN CONSIDERATIONS

The new electrical design of the modified ASNI with the addition of the ANODE function determined the redesign of the physical configuration. The main filters, phase-lock loop/demodulator, logarithmic ratio module, and frequency synthesizer are constructed as separate printed wiring board assemblies. The power supply is mounted on an aluminum bracket. The electronic design required a total internal mechanical redesign while the external housing was not changed appreciably.

3.1 ELECTRICAL DESIGN

To understand the Spartron ID-1872/A MOD, refer to figure 3-1 and the circled numbers used to aid in the description of signal content at various input and output ports. Dashed lines show which circuits are on each printed-circuit board, and the operational amplifier callouts at this level will aid in an understanding of the detailed circuitry found in the schematic diagrams. The appendix shows a photograph and a schematic diagram of each printed wiring board.

3.1.1 Input Stage

The FM demodulated composite DIFAR signal enters the ID-1872/A MOD at (1). In the case of the AN/SSQ-77 sonobuoy, this signal consists of omnidirectional channel information, an unmodulated frequency pilot, a phase pilot, and a suppressed phase pilot with sideband information consisting of multiplexed sine and cosine hydrophone information, referred to as the north-south and east-west directional channels.

An AN/ARR-72 or AN/ARR-75 receiver's high audio output produces a 22.625-V peak signal for a full undistorted ± 75 -kHz deviated FM signal from an on-channel sonobuoy transmitter and hence must be attenuated for use with the ± 15 -V power supply level of the ID-1872/A MOD circuitry. On the other hand,

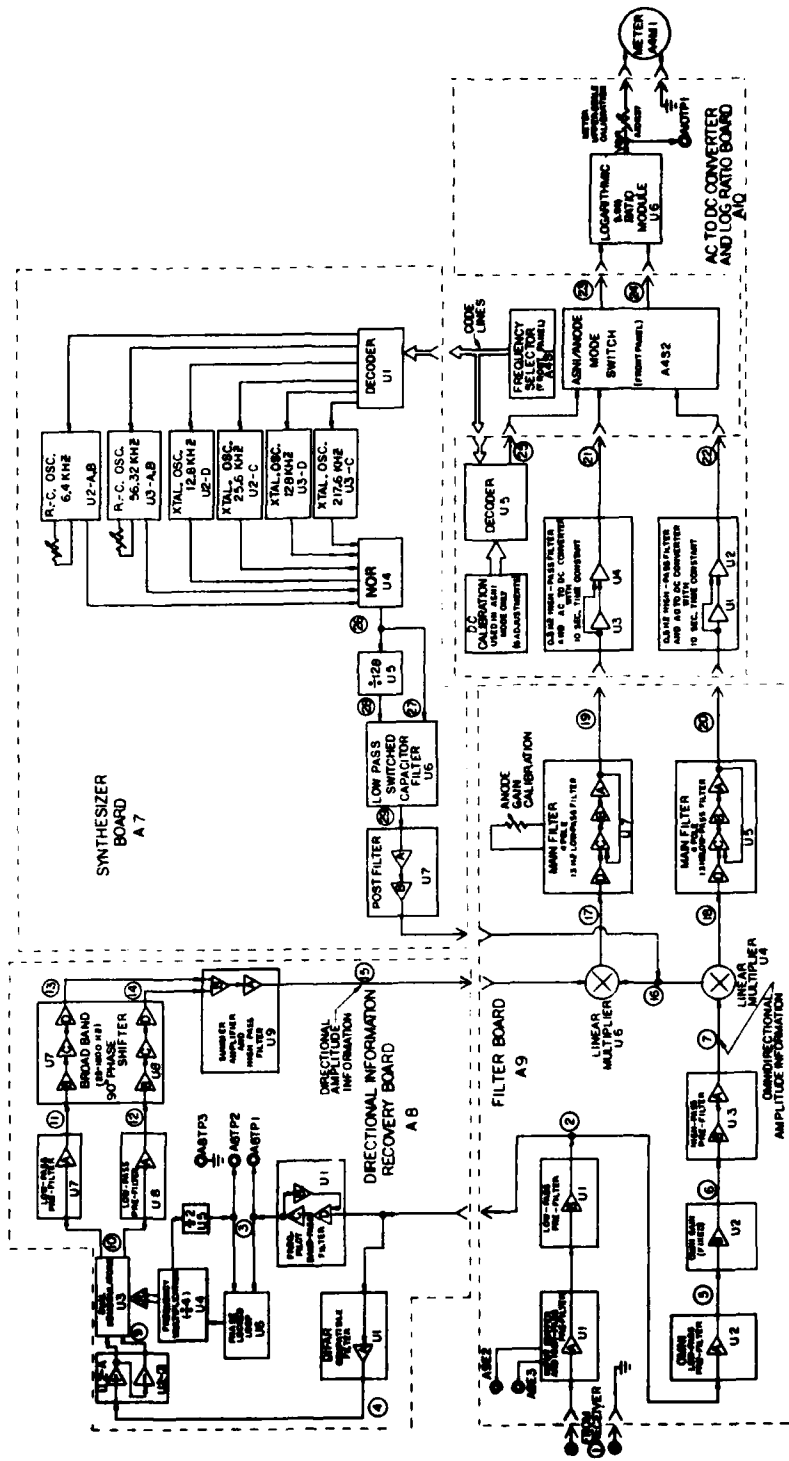

Figure 3-1. ID-1872/A MOD Block Diagram

the standard AN/ARR-75 receiver's output is one-eighth that of the high audio output and is amplified for compatibility. The input buffer stage, A9U1, performs this function as well as providing input overvoltage protection and one section of high-pass prefiltering. Removing the jumper wire between A9E2 and A9E3 provides standard audio receiver compatibility. Standard receiver compatibility is also useful for checking VLAD tapes in the laboratory with the ID-1872/A MOD as a bench unit.

3.1.2 Prefilters

The composite signal is split into three paths to be prefiltered at (2). At (3) the unmodulated frequency pilot is extracted by a bandpass filter. Likewise, at (4) both the upper and the lower directional information sidebands are extracted by a DIFAR filter stage, A8U1-A. This stage, in conjunction with the specific pole locations of A9U1-B, provides upper to lower sideband phase linearity and undistorted amplitude characteristics necessary to preserve directional channel amplitude information. At (5) only the omnidirectional channel information is passed by a low-pass filter. At (6) this omnidirectional signal is amplified to compensate for system dynamic range performance for use with the AN/SSQ-77 in the ANODE mode and the AN/SSQ-57 in the ASNI mode, so that sea state 6 noise levels can be handled with less than 1 dB of compression. At (7) infrasonic information is removed by a multipole, multizero, high-pass filter. One pole-zero is part of A9U1-A and the remaining pole-zeroes are part of the A9U3 stage. The signal at (7) is the omnidirectional channel amplitude information and is ASNI/ANODE frequency compatible from 37 to 1800 Hz.

3.1.3 Phase-Lock Loop

The phase-lock loop at (8) provides a narrow-band quadrature output at twice the incoming frequency for system use in center tuning the dual double-balanced demodulator A8U3. The phase-lock loop is not used to lock directly to the phase pilot since the phase pilot is modulated in the sonobuoy by possible high-level low-frequency bearing components or sonobuoy suspension noise, creating potential jitter problems. The frequency pilot is not modulated and thus does not exhibit jitter problems.

The phase detector compares the incoming sinusoidal frequency pilot at (3) to the derived square-wave frequency pilot available at TP2 and outputs a dc term corresponding to the phase difference between the two signals. A loop filter amplifies the dc component while filtering noise components. The dc output is used to adjust the voltage-controlled oscillator (VCO) to a frequency 8 times that of the frequency pilot. The phase detector, the loop filter, and the VCO are all part of A8U6.

The VCO output frequency is then divided by 4 and a dual D flip-flop, A8U4, provides multiphase components. These output components are of the exact frequency of the phase pilot when the loop is in lock. To complete the loop, the phase pilot frequency is divided in half by a flip-flop A8U5 and is used as the derived frequency pilot for the phase detector. When lock is achieved, the signals available at A8TP1 and A8TP2 (viewed on a dual-trace oscilloscope) will be locked in phase with respect to each other.

3.1.4 Demodulation and Directional Amplitude Information Recovery

Due to the DIFAR filter, the signal present at (4) contains very little of the odd harmonic components transmitted by the digital multiplexers found in most sonobuoys. If sea noise was directional, which is often the case, the odd harmonics could present an ANODE system error of slightly greater than ± 1 dB. Since the filter provides at least 20 dB of rejection, the system error due to harmonic content is only ± 0.1 dB.

The signal at (4) is next gently high-pass filtered (-3 dB at 1000 Hz) and phase split by A8U2 to provide double-balanced signals for demodulation at (9). The demodulators are center tuned and quadrature driven at (8), resulting in two output signal paths at (10) containing sum and difference terms. Only the difference terms are desired, and they are extracted by two low-pass filters. These filters use 1% components and are identical to the omnidirectional low-pass filter, A9U2-A. The signals at (11) and (12) are phase coherent relative to each other and at any possible angle relative to the unrecovered phase pilot. (These signals are not truly demultiplexed, since bearing information is not an ANODE system necessity.) To combine these

signals in a true rms fashion, phasor addition techniques are further employed by making use of a broadband, all-pass, 90° phase shifter. The signals at (11) and (12) are in phase or out of phase, depending upon the sea noise characteristics, and being shifted 90° at (13) relative to (14) results in two noise vectors whose individual spectral components are always perpendicular. The two baseband noise components are summed by vector addition and fixed gain amplified by A8U9 to a level such that sea state 6 noise will result in less than 1 dB compression. A8U9 is also a high-pass filter, removing the unwanted infrasonic noise components. The signal at (15) is the directional channel amplitude information and is ASNI/ANODE frequency compatible from 37 to 1800 Hz.

3.1.5 Linear Multipliers and Main Filters

One of six ID-1872/A MOD internally generated sinusoidal tones between 50 and 1700 Hz is selected with front panel switch A4S1 and utilized at (16) by the two linear multipliers A9U4 and A9U6. Noise information from the directional and omnidirectional channel is present at (17) and (18), respectively, in the form of sum and difference terms. For narrow-band analysis only the difference terms are desired. They are removed by the 4-pole, 0.1-dB ripple, Chebychev, low-pass main filters. These filters utilize only 1% tolerance resistors and capacitors and are matched in frequency characteristics. No inductors are used in these filters.

The filters flatly pass all the difference terms from dc (zero beat) to 10 Hz within ±0.1 dB. The -3-dB frequency is at 13 Hz, and the -20-dB frequency is at 20 Hz. Fixed gain is provided in the omnidirectional main filter to keep the gain bandwidth a constant for sea state 6 noise compatibility. The gain of the directional main filter is identical except that the independent gain summing junction in A9U7 is controlled by a variable resistor, which is the system's only ANODE (directional to omnidirectional gain difference) calibration adjustment.

The linear multipliers and the low-pass main filters perform a 26-Hz narrow-band analysis of sea noise at six selected frequencies by frequency translation. The outputs at (19) and (20) resemble the envelopes of the actual

band-limited sea noise at the various frequencies and not the noise itself. With the following converter circuitry this, however, lends itself to a repeatable and accurate approximation of the actual narrow-band sea noise amplitude information.

3.1.6 AC-to-DC Converter

The linear multiplier zero beat term ($A \sin \theta + B \cos \theta$) technically does not have to be removed, since the analysis frequency oscillator is a freely rotating vector relative to the sea noise (that is, they are not phase locked). However, with only a 10-second integration time constant, extremely slow meter fluctuations can be observed. Also, system dynamic range requirements of greater than 50 dB cannot be met if the dc offset terms of the linear multipliers and active gain amplified low-pass filters are allowed to pass through to the meter.

To meet these ends, a 0.5-Hz high-pass filter is included in each signal path. A 1-Hz segment is removed from the center of the band, resulting in a net 25-Hz analysis frequency bandwidth and a noise correction factor of $\sqrt{25}/\text{Hz}$, or 5:1. For the ASNI mode, expressed in decibels, this represents 14 dB. Figure 3-2 shows the system bandwidth graphically. Note the null at center frequency.

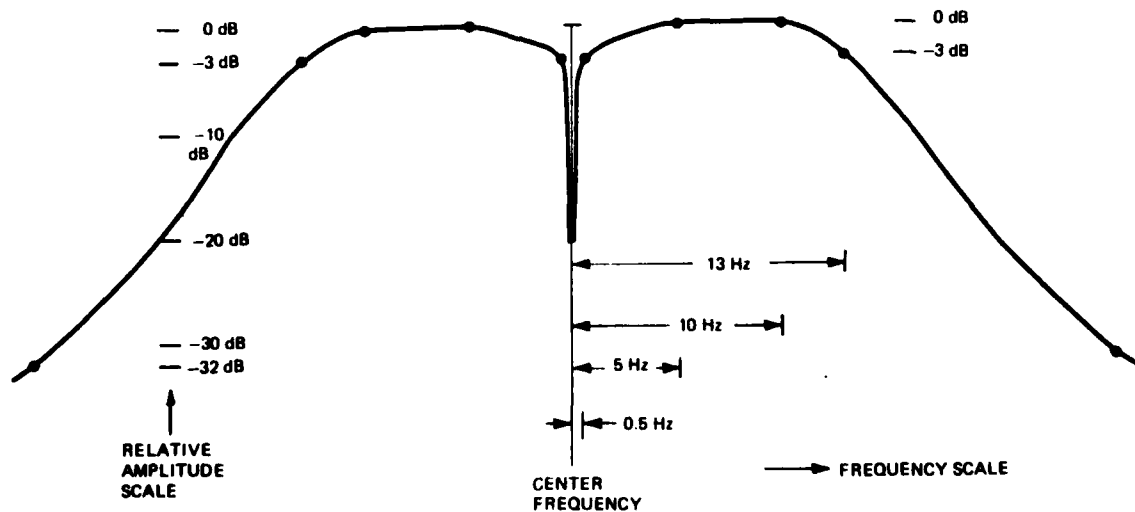

Figure 3-2. System Bandwidth

The noise bandwidth signals are next precision full-wave rectified and integrated for 10 seconds, yielding at (21) and (22) dc voltages representative of the directional and omnidirectional sea noise, respectively. Amplifiers A10U1 through A10U4 are special precision, low-offset, low-bias devices contributing negligible dc error.

3.1.7 Mode Switch and Log Ratio Module

In the ANODE mode, the voltage at (21) is fed to (23) to be used as the log ratio module's signal input. The voltage at (22) is fed to (24) and is used as the log ratio module's reference input. The module's transfer function in the ANODE mode is:

$$V_{\text{out}} = -\left[\log \frac{V \text{ at } (21)}{V \text{ at } (22)}\right] - 1.5 \text{ V}$$

For example, if the directional noise voltage at (21) is 10 times that of the omnidirectional noise voltage at (22) (a 20-dB difference), $V_{\text{out}} = [-\log 10] - 1.5 = -1 - 1.5 = -2.5$ volts. V_{out} is available at A10TP1 (table 3-1).

It can be seen that once the initial offset factor of -1.5 V for 0 dB is taken into account, for every ANODE 1-dB change a 50-mV change occurs at A10TP1, the voltage out test point.

In the ASNI mode the voltage at (21) is not used at all. The omnidirectional voltage at (22) is passed to become the log ratio module's signal input at (23). The front panel frequency selector switch, A4S1, via code lines and decoder A10U5, presents one of six separate dc calibration voltages at (25)

Table 3-1. ANODE Voltage

| ANODE (dB) | Volts at A10TP1 (V_{dc}) |
|---------------|--|
| 0 | -1.5 |
| 10 | -2.0 |
| 20 | -2.5 |
| 30 | -3.0 |

that in turn is routed by the mode switch to the log ratio module's reference port at (24) . The ASNI transfer function is

$$V_{out} = -[\log \frac{V \text{ at } (22)}{V \text{ at } (25)}] - 1.5 \text{ V}$$

Note that the ASNI scale is marked 70 dB higher than the ANODE scale. If the voltage at (22) equals the frequency-dependent calibration voltage at (25) , the ASNI scale on meter A4U1 will read 70 dB and the voltage at A10TP1 will be -1.5 V dc (table 3-2). For every ASNI decibel, a change of 50 mV occurs at A10TP1.

A10TP1 is used in conjunction with an external precision digital voltmeter for calibration of the single ANODE gain potentiometer and the six ASNI reference voltage potentiometers.

Calibration is independent due to the mode switch function. If the ANODE function is being calibrated with a DS-10 simulator (standard level) or a comparable DIFAR simulator, for a +10 dB reading at 50 Hz, do not adjust the 50-Hz ASNI calibration potentiometer; it is not in the circuit in the ANODE mode. The ANODE mode contains no frequency adjustments due to the nature of the matched filters used throughout the system. Even though 1% tolerance

Table 3-2. ASNI Voltage

| ASNI (dB) | Volts at A10TP1 (V _{dc}) |
|--------------|---------------------------------------|
| 40 | 0 |
| 50 | -0.5 |
| 60 | -1.0 |
| 70 | -1.5 |
| 80 | -2.0 |
| 90 | -2.5 |
| 100 | -3.0* |

*Readings above 91 dB are not representative of pure sea noise. Discrete in-band tones are present.

components are used, some change in ANODE calibration versus frequency will be noted, typically ± 0.2 dB.

Once the system has been calibrated using A10TP1, the front panel meter is adjusted. First, with all power off, the "zero" is adjusted for 40 dB on the ASNI scale with the adjustment on the meter face. Then, with the power on, in the ANODE mode, using the DS-10 simulator with a reading of -2.0 V dc at A10TP1, the meter upper scale potentiometer A10R37 is adjusted for +10 dB on the meter. Similarly, using table 3-2 in the ASNI mode, any upper scale A10TP1 voltage may be chosen for meter calibration.

3.1.8 Synthesizer Board

The sole purpose of the synthesizer is to provide any one of six sinusoidal waveforms at 50, 100, 200, 440, 1000, or 1700 Hz with a peak output voltage of 10 ± 1 V for use by the two linear multipliers at (16) .

The dc code lines generated by the frequency selector switch enter board A7 and are decoded by decoder A7U1. One of six oscillators is enabled based upon the code. Each oscillator when enabled operates, outputting a square wave at 128 times the desired board output frequency. A7U4 passes the operating oscillator to a divide by 128 at (26) and to the clock input of the switched capacitor filter at (27) . The divide by 128 at (28) presents a square wave at the desired synthesis frequency to the input port of the switched capacitor filter, A7U6. A7U6 is a 7-pole low-pass filter whose corner frequency is at 1.28 times its input frequency. At (29) the waveform, due to filtering, is a sine wave. The postfilter stage A7U7 removes clock residue and amplifies the signal to the proper level. This synthesized signal is the signal used by the multipliers at (16) .

3.1.9 Power Supply

The power supply used by the system is a modular unit (whose block diagram is not available from the manufacturer) mounted on a separate subchassis plate and is designated assembly eleven (A11). It is a ± 15 -V regulated supply with a maximum current output rating of 200 mA. ID-1872/A MOD circuit drain is

120 mA, nominal. The power supply's voltage regulation is $\pm 1\%$, which is adequate for system use. The power supply is capable of operating on 60 Hz as well as 400 Hz input power, which makes it useful as laboratory equipment. One word of caution, however: the ID-1872/A MOD main power circuit breaker is rated at 400 Hz and will require a greater-than-rated overload before it trips at 60 Hz. For permanent laboratory use at 60 Hz power, it is recommended that the circuit breaker be changed to a 60-Hz rated unit or that a 0.5-A slow-blow fuse be added to the power line.

3.2 MECHANICAL DESIGN

Four areas required consideration. So the new ID-1872/A MOD unit could be installed easily in the aircraft, the overall external configuration of the unit was maintained (figures 3-3 and 3-4). An ASNI/ANODE function switch was installed on the front of the unit and the ANODE scale was added to the front panel meter. A total internal redesign was accomplished.

3.2.1 External Configuration

The external housing did not change (figure 3-5). The two connectors on the rear panel of the housing are in the same location and serve the same function. The housing is 5 inches wide, 7 $\frac{3}{8}$ inches high, and 6 $\frac{1}{2}$ inches deep. The front panel is 5 $\frac{3}{4}$ inches \times 8 $\frac{3}{16}$ inches. The modified unit can be inserted easily into the space vacated by an unmodified ID-1872/A unit. The ANODE scale was added to the panel meter and an ANODE/ASNI function switch was installed on the lighted panel.

3.2.2 ANODE/ASNI Function Switch

To provide a comparison between the omnidirectional and the directional information being received, a switch was placed on the edge-lighted panel. Upon initial inspection, there seemed no logical location for this switch since the original design of the first GFE unit had wires embedded in the plastic of the panel that supplied current to the panel lights. A subminiature toggle switch was placed in the lower right-hand corner between two wire traces.

Figure 3-3. Unmodified
ID-1872/A ASNI



Figure 3-4. ID-1872/A MOD ASNI
(with ANODE Modification)

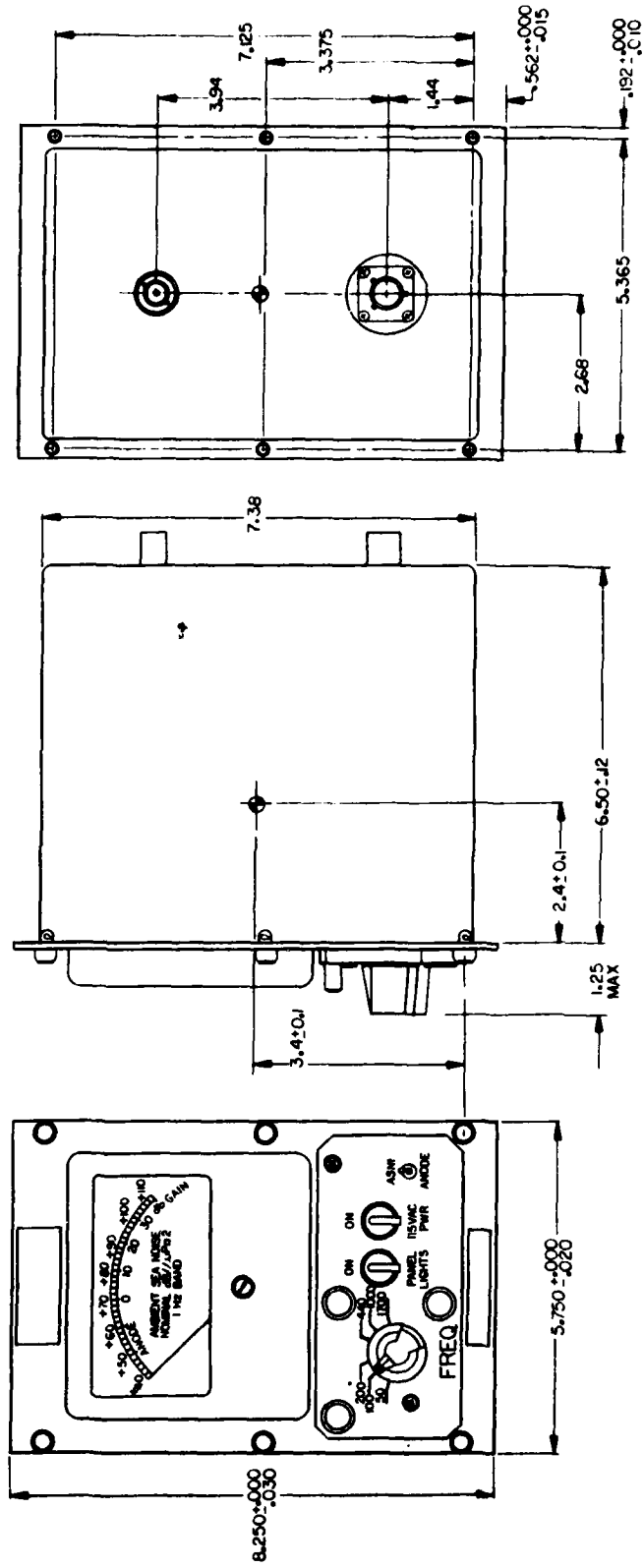

Figure 3-5. ID-1872/A MOD External Dimensions

The second GFE unit was from a different vendor. On this unit the 28-V connector on the upper right-hand corner of the edge-lighted panel was oriented 45° from the connector on the first unit. The embedded wires were in the way of locating the ANODE/ASNI function switch in the same location. When a test hole was cut into the panel, the wire trace was severed. The area was routed, the wires were spliced, and the hole was filled with liquid plastic. A new location was chosen just to the left of the first location. On future redesign of GFE units, the location of the switch in relation to the embedded wire traces will be a definite concern.

3.2.3 Panel Meter

The ID-1872/A's panel meter was modified by having the ANODE scale placed between the original ASNI scale and the mirror. Zero was chosen as near mid-scale as possible. To utilize the original scale, ANODE divisions of 0, 10, 20, and 30 dB were placed at ASNI divisions of 70, 80, 90, and 100 dB, respectively. Each small scale division represents 2 dB of gain.

3.2.4 Internal Redesign

The original locations for printed circuits were not used (figure 3-6). Four printed-circuit boards with an overall measurement of 4 1/2 × 5 3/4 inches stacked 5/8 inch apart were mounted on the back wall of the unit (figure 3-7). The space between the four circuit boards and the front panel was used for the power supply.

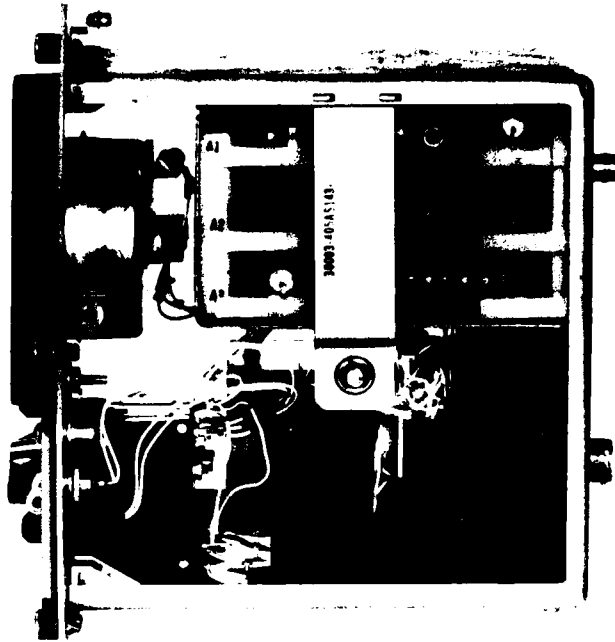

Figure 3-6. Unmodified ID-1872/A ASN1 Internal Configuration

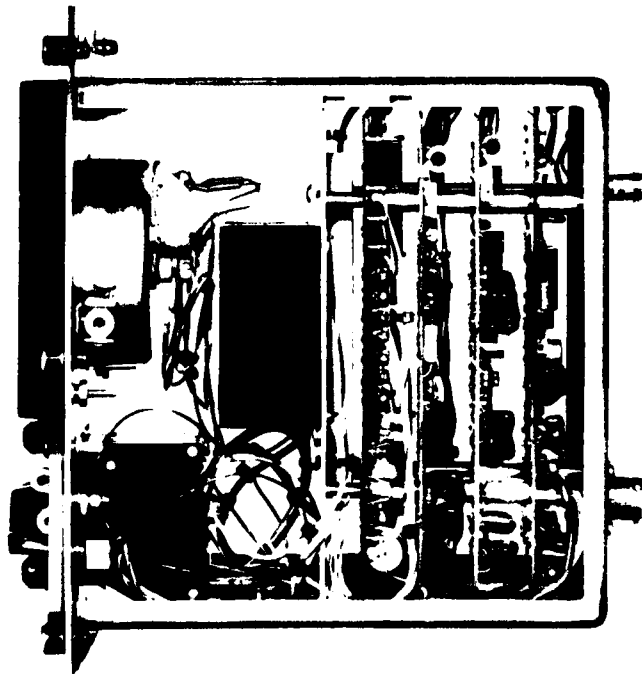

Figure 3-7. ID-1872/A MOD Internal Configuration

SECTION 4
DESIGN REVIEW

On 6 May 1981, a design review meeting was held at Sparton's Jackson facility. Attending from NADC were Mr. Houser and Mr. Imhof. Mr. Keane was also present. Sparton personnel were:

| | |
|-----------|---------------------|
| E. Albers | Program Manager |
| C. Boyle | Chief Engineer |
| W. Ezell | Project Engineer |
| C. Mast | Engineering Manager |
| D. Zenz | Technical Writer |

After the introductions, NADC presented an overview of the ANODE program and its relationship to other programs. Sparton reviewed the program status and the schedule.

The hardware design was presented. A block diagram, accurate as of that date, was distributed and a verbal technical discussion was presented. Sparton's design approach was acceptable. Questions arose concerning the 3-dB discrepancy between perfect isotropic versus dipole noise patterns. The adequacy of the 10-second integration time constant, a specification requirement, to stabilize meter fluctuations under random noise conditions was also discussed. These matters were at a later date investigated with actual sea tapes left by NADC of AN/SSQ-77 and AN/SSQ-53 receptions.

The sea tapes revealed that the 10-second time constant is adequate to record measurements without excessive needle bounce and still quick enough to respond to sudden sea noise variations and fluctuations. For these tapes, sea noise was not isotropic and Sparton did not incorporate the theoretical 3 dB into the ANODE units. However, a potentiometer is provided to change the ANODE gain by ± 3 dB if the need arises.

A breadboard demonstration was conducted. Both a broadband noise generator and an oscillator were used as input sources. Levels were changed and meter readings were witnessed. Breadboard operation was acceptable to all.

Various aspects of the program were summarized and the design review meeting was concluded.

SECTION 5
CONTRACTOR DEMONSTRATION TEST

After submission and approval of the test plan, contractor demonstration tests were held on 14 and 15 July 1981 at Sparton's Jackson facility.

On 14 July, the first test was a special test. The two modified GFE units had their inputs connected in parallel to a tape recorder with tapes of sea noise (provided by NADC). Sparton verified that the units were functionally identical. An inband discrete tone discovered on one of the tape tracks was also played back. Before the disturbance, ANODE readings from 14 to 20 dB were realized. The readings dropped to 0 dB for nearly one-half minute while the disturbance was strong. The disturbance was in the center of the 100-Hz analysis band. The results of this test were as predicted by theory and very encouraging.

Another special test measured noise in a wide band and compared it to the ASNI/ANODE narrow-band noise level. The unit appeared to be consistently reading about 1 dB low. Results were acceptable, however, due to noise source specification accuracy of ± 1 dB over the wide band. One unit was selected to be used for the remainder of the test. All tests indicated that the unit was within specification. All of the room temperature tests listed in the test plan and a majority of the 40°C and 0°C tests were run. There were no marginal readings.

SECTION 6
CONCLUSIONS

The ASNI/ANODE modification of the program was intended to modify two GFE ID-1872/A units to include the ambient noise directionality estimator function. The ID-1872/A GFE units that arrived were originally constructed to indicate the actual ambient sea noise from an AN/SSQ-57 sonobuoy. The modification was intended to keep the ASNI function intact and add the ANODE function.

During the design phase of the ASNI/ANODE Indicator program, five goals emerged as most significant:

- Maintain overall external configuration
- Maintain original ASNI function
- Design and add ANODE function
- Utilize original meter
- Obtain a ± 1 -dB accuracy at 25°C and ± 5 -dB accuracy at 0°C and 40°C for frequency range

All five design goals were met, and the modified units functioned well within specification limits. Both the design review meeting and the contractor demonstration tests revealed that the Sparton modification to the ID-1872/A was highly successful.

Sparton recommends the following suggestions be considered in future ASNI modifications:

- (1) A gasket should be installed between the dust cover and the unit's front panel
- (2) Units from only one vendor should be modified to eliminate the problem with the wire traces imbedded in the plastic of the lighted panel
- (3) A frequency change to 55, 110, 220, 440, 880, and 1760 Hz would simplify circuit design and lower cost since only one crystal would be needed for the oscillator circuit instead of an oscillator circuit for each frequency

- (4) A digital meter with an accuracy to 0.1 dB could be used to avoid analog meter vibration problems; the display should be read to the nearest whole decibel
- (5) The specification accuracy should be changed to ± 1 dB at 25°C and ± 2 dB at 0°C and 40°C

These changes would simplify design, construction, and use. They would also provide greater accuracy and could realize a cost saving.

An analysis has been made and determined that it is feasible to add a "lock" light that would indicate when a composite signal is being received. This will discriminate against AN/SSQ-41 and AN/SSQ-57 sonobuoys as well as broadband receiver noise. Since this feature was not specified, it has not been incorporated into the current design.

The ANODE modification to the ASNI project was successful. The design meets the stipulated level of performance.

APPENDIX
PRINTED-CIRCUIT BOARD
ASSEMBLIES

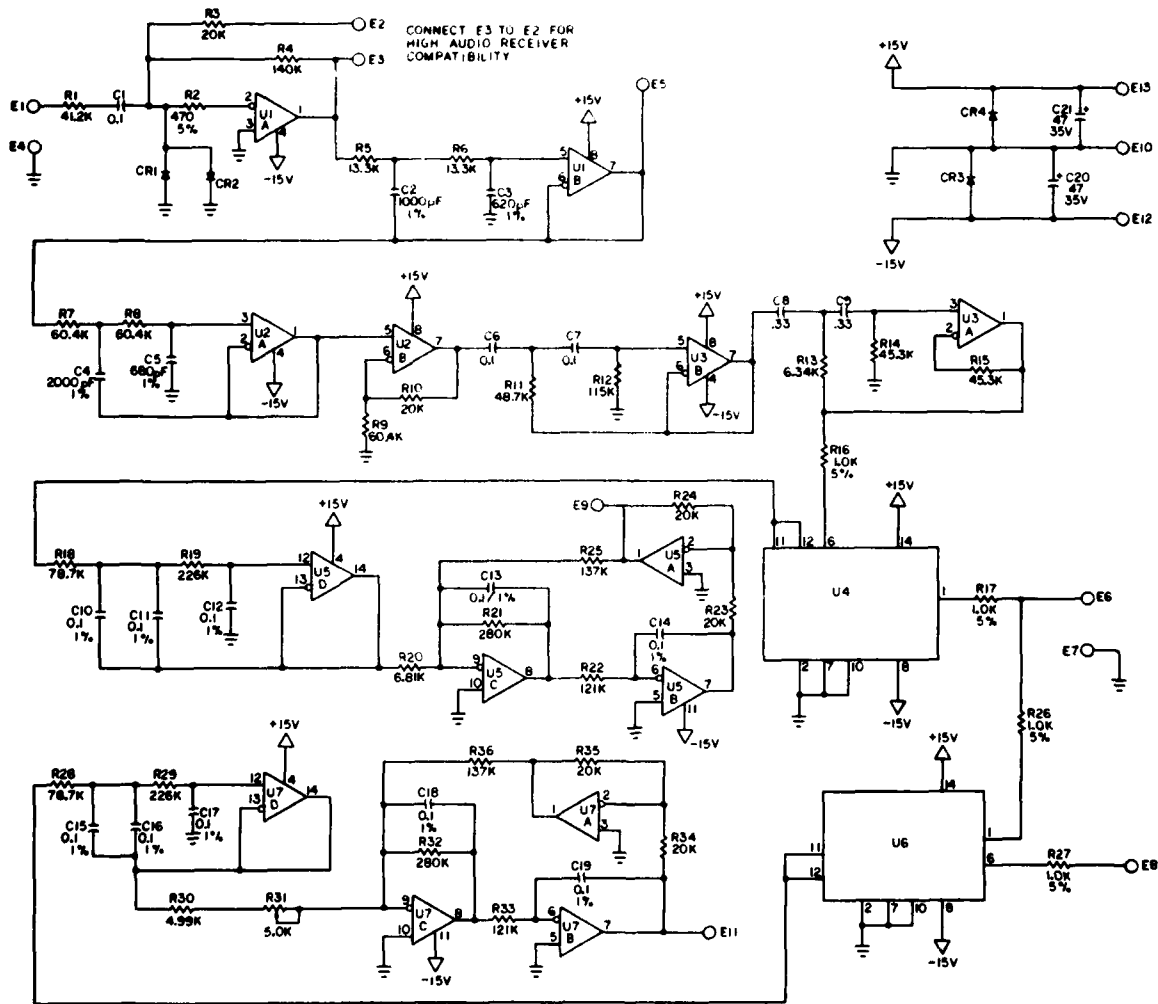
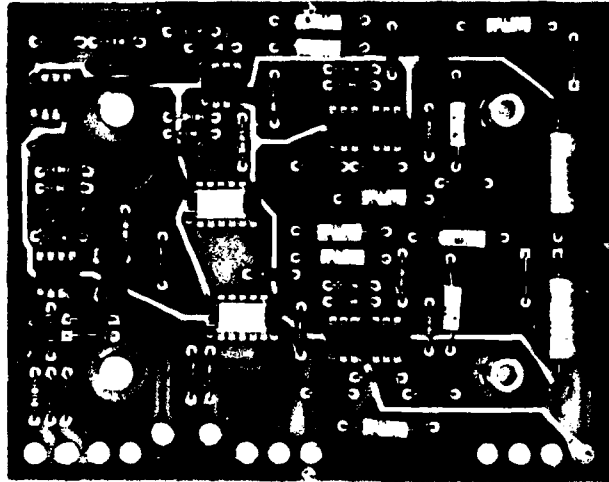

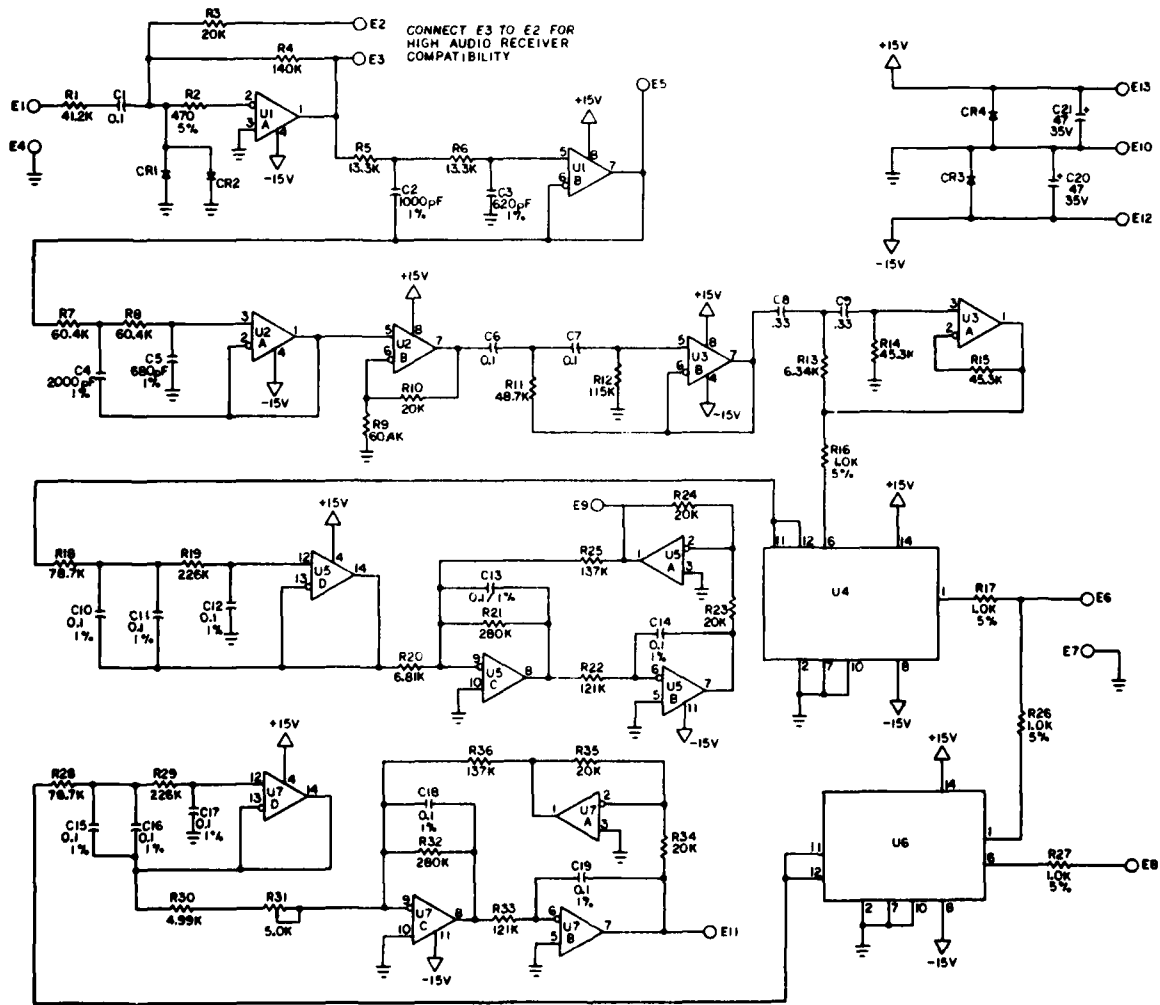
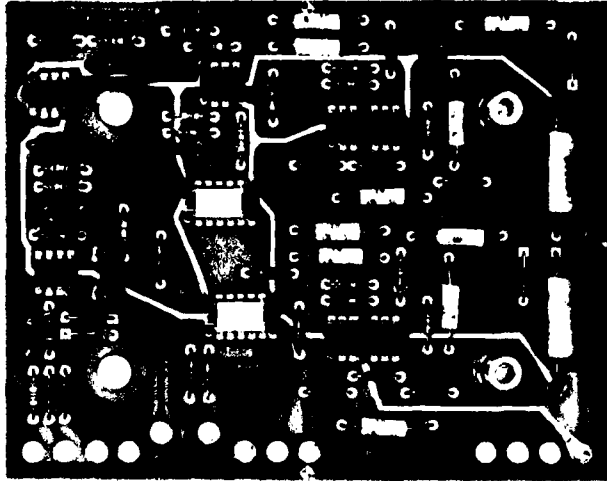

Figure A-1. Filter Board (A9)

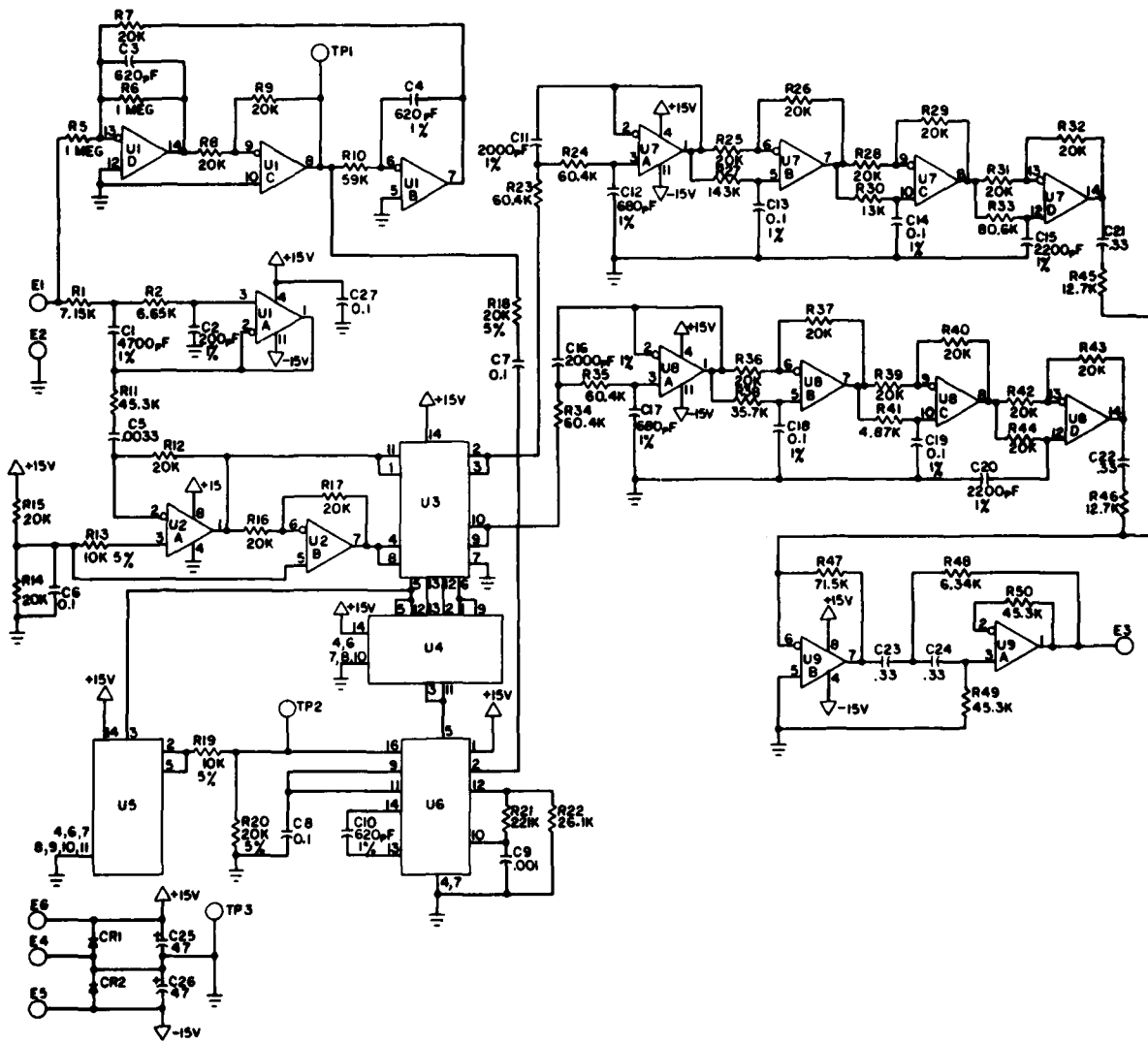
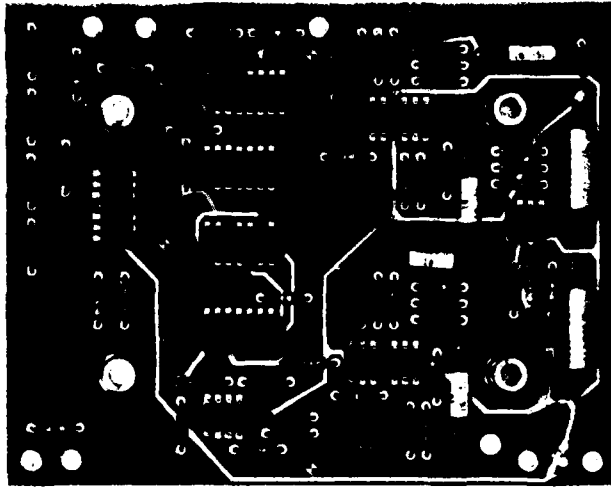

Figure A-2. Directional Information Recovery Board (A8)

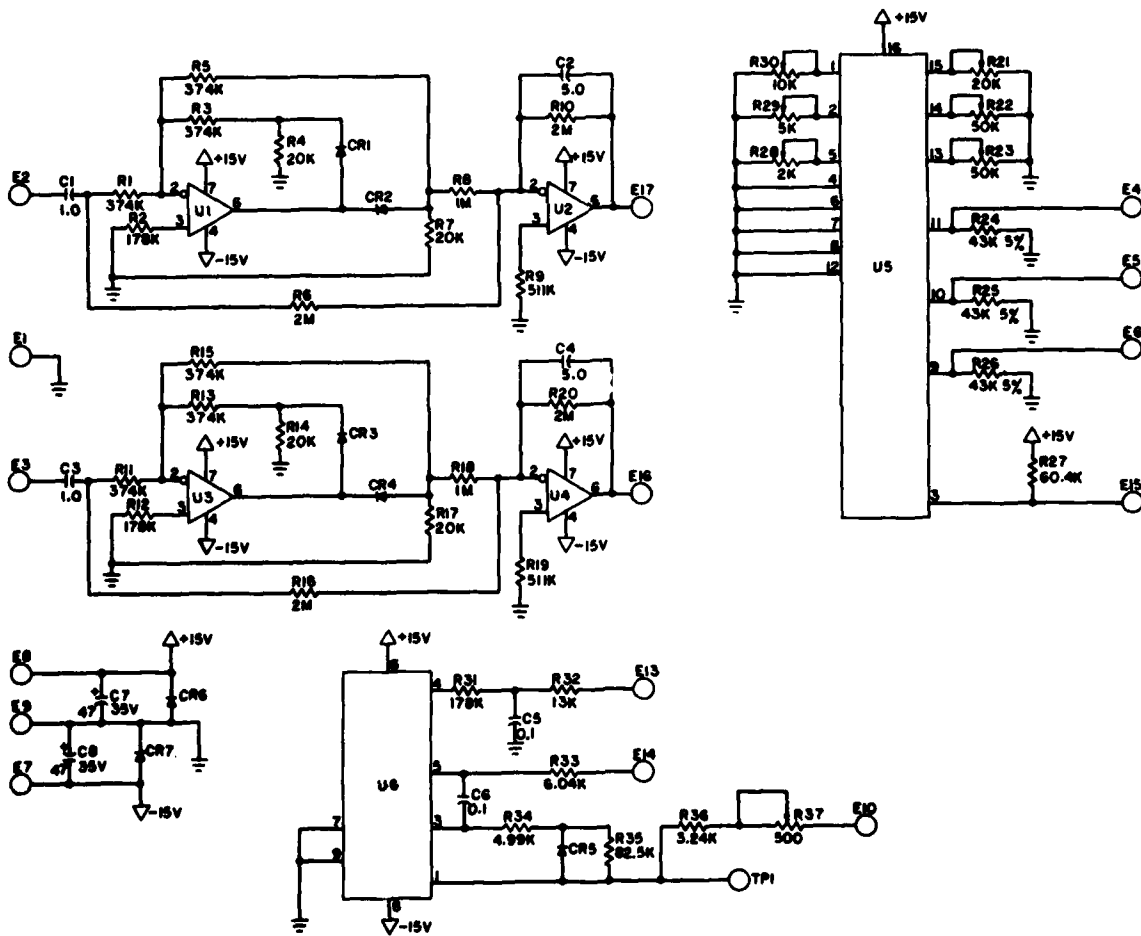
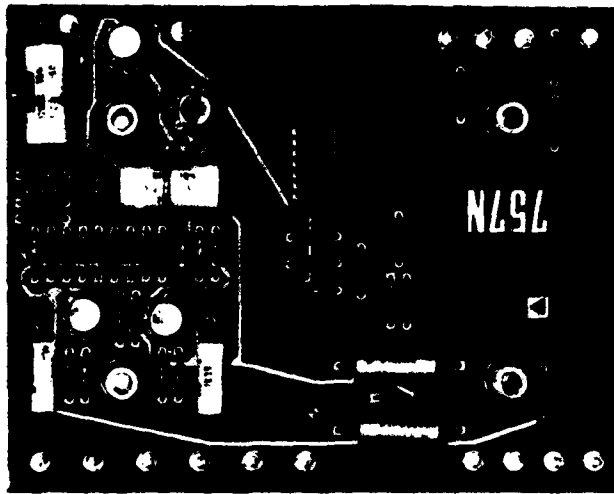

Figure A-3. AC-to-DC Converter and Log Ratio Board (A10)

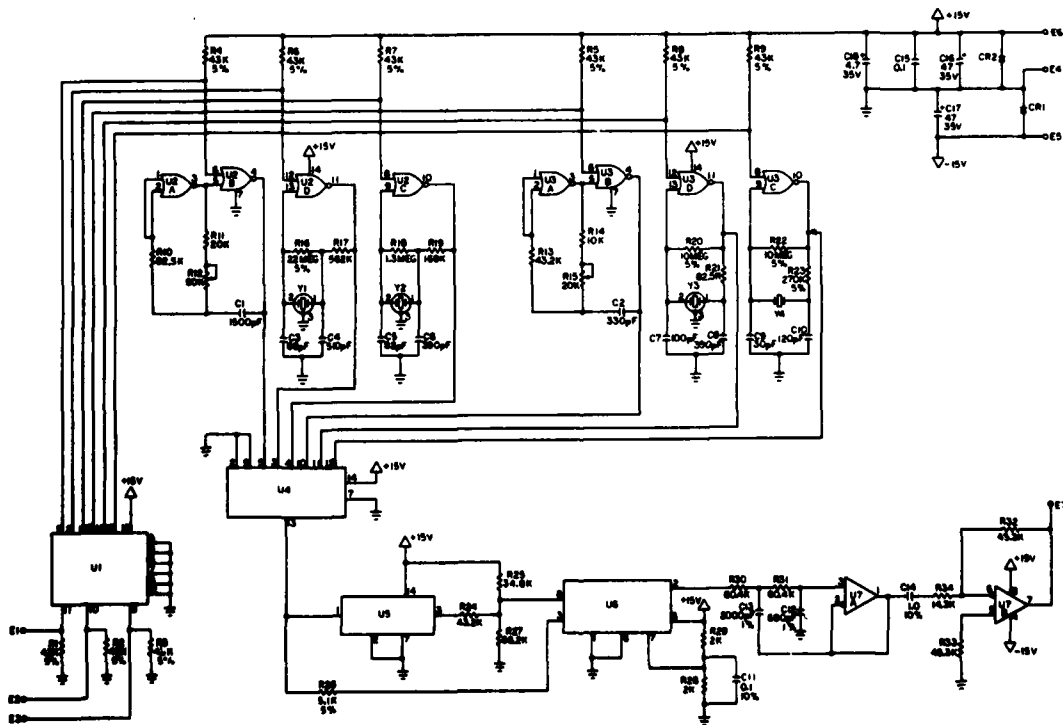
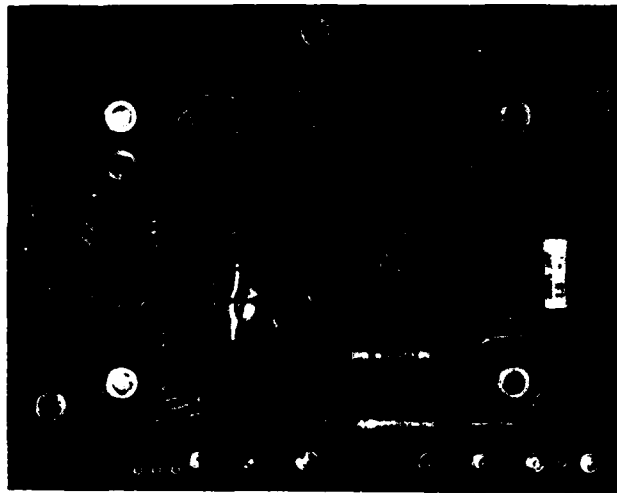

Figure A-4. Synthesizer Board (A7)

