

188 448

ARMY ARMAMENT RESEARCH AND DEVELOPMENT COMMAND DOVER--ETC F/8 17/1
ACOUSTIC TARGETING SYSTEM FOR OFF-AXIS FIRING. (U)
NOV 81 D E FREDERICKS

UNCLASSIFIED

ARTSD-TR-81003

SBI-AD-E400 729

NL

| OF |
AD A
108448



END
DATE
FILMED
01-82
DTIC

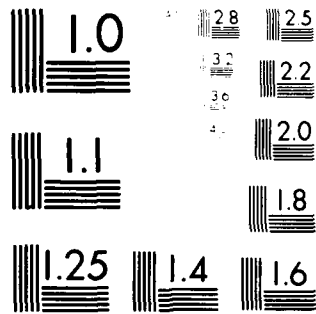

MICROCOPY RESOLUTION TEST CHART
NATIONAL BUREAU OF STANDARDS-1963-A

AD A108448

12

AD

AD-E400 729

TECHNICAL REPORT ARTSD-TR-81003

LEVEL

ACOUSTIC TARGETING SYSTEM FOR OFF-AXIS FIRING

D. E. FREDERICKS

NOVEMBER 1981



US ARMY ARMAMENT RESEARCH AND DEVELOPMENT COMMAND
TECHNICAL SUPPORT DIRECTORATE
DOVER, NEW JERSEY

APPROVED FOR PUBLIC RELEASE: DISTRIBUTION UNLIMITED.

DTIC
ELECTE
DEC 4 1981

D

81 12 04 008

DTIC FILE COPY

UNCLASSIFIED

SECURITY CLASSIFICATION OF THIS PAGE (When Data Entered)

REPORT DOCUMENTATION PAGE		READ INSTRUCTIONS BEFORE COMPLETING FORM
1. REPORT NUMBER Technical Report ARTSD-TR-81003	2. GOVT ACCESSION NO. AD-A108448	3. RECIPIENT'S CATALOG NUMBER
4. TITLE (and Subtitle) ACOUSTIC TARGETING SYSTEM FOR OFF-AXIS FIRING	5. TYPE OF REPORT & PERIOD COVERED Final Jan 1975 - December 1980	
	6. PERFORMING ORG. REPORT NUMBER	
7. AUTHOR(s) D. E. Fredericks	8. CONTRACT OR GRANT NUMBER(s)	
9. PERFORMING ORGANIZATION NAME AND ADDRESS ARRADCOM, TSD Test and Instrumentation Div (DRDAR-TSE-SW) Dover, NJ 07801	10. PROGRAM ELEMENT, PROJECT, TASK AREA & WORK UNIT NUMBERS MM&T-6757589	
11. CONTROLLING OFFICE NAME AND ADDRESS ARRADCOM, TSD STINFO Div (DRDAR-TSS) Dover, NJ 07801	12. REPORT DATE November 1981	
	13. NUMBER OF PAGES 25	
14. MONITORING AGENCY NAME & ADDRESS (if different from Controlling Office)	15. SECURITY CLASS. (of this report) Unclassified	
	15a. DECLASSIFICATION/DOWNGRADING SCHEDULE	
16. DISTRIBUTION STATEMENT (of this Report) Approved for public release; distribution unlimited.		
17. DISTRIBUTION STATEMENT (of the abstract entered in Block 20, if different from Report)		
18. SUPPLEMENTARY NOTES This project was accomplished as part of the U.S. Army's Manufacturing Methods and Technology Program. The primary objective of this program is to develop, on a timely basis, manufacturing processes, techniques, and equipment for use in production of Army materiel.		
19. KEY WORDS (Continue on reverse side if necessary and identify by block number) Targeting Acoustic targeting Accuracy testing MMT-data acquisition		
20. ABSTRACT (Continue on reverse side if necessary and identify by block number) A new concept for target scoring for small caliber weapon systems has been developed, and a prototype target scoring system was installed at the Ware Simulation Section test ranges, Rock Island, Illinois. This system uses acoustic principles for detecting and target scoring supersonic projectiles. Previously, acoustic systems required that the path of the projectile be perpendicular to the target plane. The prototype system at the Ware Simulation Section uses a new dual-rod concept developed by Accubar Engineering that does not		

(Cont)

UNCLASSIFIED

SECURITY CLASSIFICATION OF THIS PAGE(When Data Entered)

20. ABSTRACT (Cont)

require the path of the projectile to be perpendicular to the target plane. This unit allows accurate target scoring of projectiles fired from a test platform that may be moving in combined yaw-and-pitch motion.

Accession For	
NTIS GRA&I	<input checked="" type="checkbox"/>
DTIC TAB	<input type="checkbox"/>
Unannounced	<input type="checkbox"/>
Justification	
By _____	
Distribution/	
Availability Codes	
Dist	Avail and/or Special
A	

UNCLASSIFIED

SECURITY CLASSIFICATION OF THIS PAGE(When Data Entered)

CONTENTS

	Page
Introduction	1
Principles of Acoustic Targeting	1
System Description	6
System Functioning	9
Acceptance Testing	12
Conclusions	15
Recommendations	15
References	17
Distribution List	19

TABLES

1	Algebraic difference between scoring by ATS-16D measured paper targets for 5.56-mm ammunition (targets A through J)	13
2	Variances and standard deviations for acceptance testing	14

FIGURES

1	Scoring produced by expanding shockwave	2
2	Relationship of projectile shockwave to rod sensors	2
3	Expanding elliptical shockwave and dual rods	4
4	Dual rod sensors in both the x- and the y-plane	7
5	Accubar ATS-16D control unit	8
6	Functional block diagram for ATS-16D	10

FIGURE PAGE BLANK-NOT FILLED

INTRODUCTION

Acoustic principles have been used for several years in determining the x-y coordinates of supersonic projectiles scoring. However, the axis-of-fire had to be perpendicular to the plane of the target area. Since firings from the six-degree-of-freedom simulator at the Ware Simulation Section are not always perpendicular to a fixed target area, a new system was developed¹.

PRINCIPLES OF ACOUSTIC TARGETING (ref 2)

A projectile ballistic exceeding the speed of sound creates a shockwave perpendicular to the shock front. The high energy, fast-moving shockwave appears as a cone, expanding at the speed of sound (fig. 1) and can easily be detected by ceramic piezoelectric transducers. These are located on the ends of aluminum sensor rods which are mounted at the edges of the scoring plane. The transducers detect the shockwave that has been induced into the metal rods. The relationship of shockwave to transducer rods is shown in figure 2. The expanding shockwave strikes the rod sensors at tangent points, generating secondary shockwaves within each rod. These secondary waves move in opposite directions at the speed of sound in metal (approximately 15 times the speed of sound in air) and excite the transducers at the rod ends. Each of the rods and its associated transducers and circuitry acts independently of the other to provide one axis of the readout.

In the example shown in figure 2, the round passed through the target plane high and to the left of center. The point of tangency on the y-axis results in the secondary shockwave reaching the top transducer first; this action starts an electronic clock circuit, and when the secondary wave in that rod reaches the bottom transducer, the clock circuit is shut off.

Appropriate circuitry allows a readout or display of the accurate location of the initial point of tangency. When the shockwave reaches the x-rod, these actions are duplicated in the x-axis. The resulting x-y coordinates can give, to within 0.25 cm, the point where the round passed through the scoring plane.

The relative measurement that is occurring in the rod sensors makes this target scoring system unique. The intensity and rise-time of the ballistic shockwave are unimportant and have no effect on accuracy. The total length of the rods and any changes in the rod lengths because of temperature do not effect accuracy.

¹ Contract DAA08-78-C-0259, Accubar Engineering, Box 350, Woolverton Way, Alexandria, PA 16611.

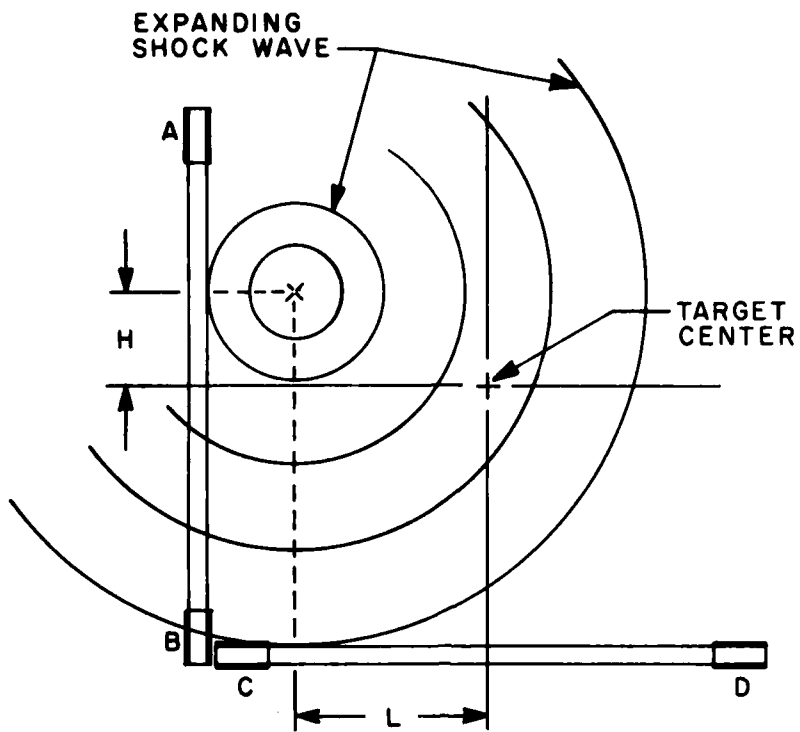

Figure 1. Scoring produced by expanding shockwave

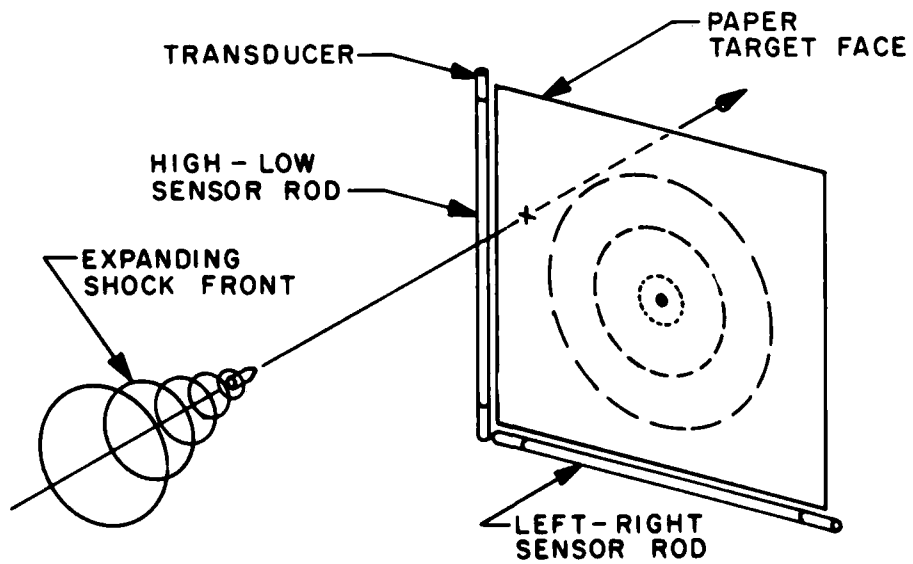

Figure 2. Relationship of projectile shockwave to rod sensors

The final display of the hit-or-miss location can be in a form that is amenable to the system requirements; it can be a digital lamp display, paper printout, cathode ray tube display, or cards punched for computer analysis. An important feature is the rapid reset time and, therefore, the rapid scoring. By the use of a 1.2-m square target as an example, the acoustic disturbance from the shockwave will pass the rods within 5 to 15 milliseconds. This time allows the transducers to score shots spaced 10 to 15 milliseconds apart and results in the scoring of approximately 4000 to 6000 shots-per-minute.

The dual-rod concept is employed when it is necessary to eliminate off-axis errors that occur if the projectile flightpath is not perpendicular to the scoring plane. In most test firings in which acoustic systems are employed, the weapon is situated so that the flightpath is normal to the scoring plane and the system operates as described above.

If the projectile flightpath is not perpendicular to the target plane, the intersection of the ballistic shock cone and the target plane results in an elliptical cross-section rather than the normal circular cross-section. This expanding ellipse (fig. 3) strikes the rod sensors at tangent points (major and minor axis) which do not originate at the projectile impact point. The off-axis error that would be introduced when only one rod in the x-axis and one rod in the y-axis are used can be eliminated by the coplaner arrangement of dual rods. The rod-score points on the dual rods can be used to triangulate to the actual impact of the projectile.

An important feature of this concept is its ability to handle compound off-axis angles (azimuth and elevation) as easily as single-axis angles. Figure 3 is a geometrically correct representation of the expanding shockwave in the plane of the target for a projectile approaching from below and to the right of the target. The tangent points for the expanding wave and rods are shown for the two x- and the two y-rods. The intersection of the line through the x_1 and x_2 points with the line through the y_1 and y_2 points is the true impact point for the projectile. The intersection is no longer a function of any of the normal off-axis parameters; that is, shockwave angle resulting from projectile speed, angle of attack, or distance from the impact point to any of the rods. Any projectile passing through the same impact point, regardless of its speed or angle of attack, will produce rod scores which triangulate to that impact point.

The dual-rod system employs all the parameters necessary to accomplish this triangulation, but additional data are required to give the time of impact on each rod. The additional data, such as would result from an external pulse (T_0) allow the time counter gates in the system to measure the time between when the projectile passes a point in space and when each rod is struck by the shockwave from that projectile. By this means, determination is made of the flight vector of the projectile, the projectile velocity, and the slant range.

The intercept point is expressed by (ref 1)

$$x = \frac{b_1 - b_2}{s_1 - s_2}$$

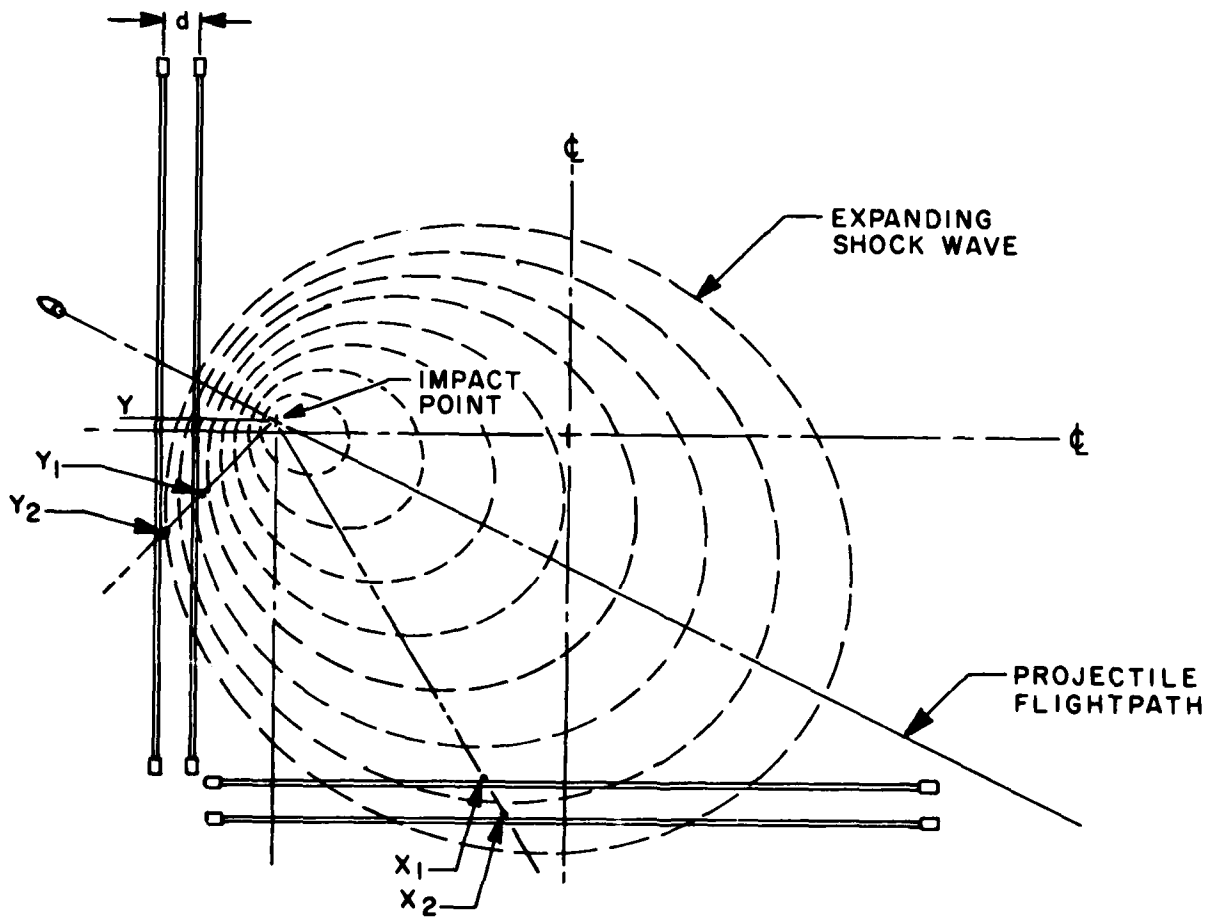

Figure 3. Expanding elliptical shockwave and dual rods

$$y = \frac{s_2 b_1 - s_1 b_2}{s_2 - s_1}$$

where

$$b_1 = y_0 - s_1 x_2$$

$$b_2 = y_2 - s_2 x_0$$

$$s_1 = \frac{d}{x_2 - x_1}$$

$$s_2 = \frac{y_2 - y_1}{d}$$

d = rod separation

A coordinate shift of $L/2$ is required since the four rod scores (x_1 , x_2 , y_1 , and y_2) are given with respect to the rod centers and the equations assume a coordinate zero at the lower left of the target shown in figure 3.

The limiting factor on accuracy with the dual-rod concept is the projection accuracy of the triangulation method. For example, if each rod is accurate to within 0.25 cm and if pairs of rods are spaced a 0.9 apart, the projection of the 0.25-cm error to the extreme of a 4.9-m target would produce a 3-cm error at the intersection.

The increased complexity of the dual-rod concept is offset by the added versatility in target use. Target and gun alignment is no longer a factor in the test setup, and the triangulation procedure is simple straight-line geometry.

This system offers a means for providing a safety interrupt for the six-degree-of-freedom simulator located at the Ware Simulation Center. This simulator can be driven in programmed motion while weapons attached to it are firing. A means for interrupting the firing circuit in case of simulator failure or excursions beyond the confines of the sand butt was required. The acoustic targeting system fulfills this safety requirement. An interrupt to the firing circuit can be provided if the projectile impact points exceed a predetermined dispersion outside the target area.

The requirement of the Ware Simulation Center for off-axis projectile scoring has been adequately met by the dual-rod concept.

SYSTEM DESCRIPTION

In the dual-rod system, Accubar model ATS-16D, coplanar arrangement of dual sensor rods is used; two rods are mounted vertically and two rods, horizontally, thus allowing the scoring points in each axis to be triangulated to the actual impact point on the target. The rod sensors (fig. 4), when mounted on the edges of the target area, detect the ballistic shockwave created by the passage of a supersonic projectile. The shockwave causes electrical pulses to be generated by piezoelectric transducers located at the rod ends. These pulses are processed within the system, and the position of the projectile, relative to the target center (of the sensor area), is automatically computed.

When the projectile flightpath is not perpendicular to the target plane, the dual rods will detect the two points of tangency that the shockwave makes with both the horizontal and vertical axes. The straight-line projection from each axis is processed by the logic circuitry in the system and the true x-y coordinates are determined. The x-y data generated by the system are automatically referenced to the center of the sensor area. The ATS-16D provides outputs which can interface to a computer and it also has a built-in light-emitting diode display for use as a standalone system. The system is capable of scoring single shots or high-rate bursts and has built-in storage for a series of scores that may constitute a firing test sequence.

The ATS-16D is configured for use in an indoor firing range. The system can provide x-y coordinate scores on projectiles of 4.5 mm caliber and above, with the provision that the velocity of the projectile not be below 400 m per sec at the scoring plane. An accuracy of ± 0.25 cm per sensor rod can be obtained under optimum test conditions.

The scoring accuracy depends on factors that are not indigenous to the system or its installation. Examples of these external factors are: velocity of projectile, normality of the flightpath to the target, and proximity of the flightpath to the sensor rods. If the test conditions and acoustic properties of the indoor firing range are optimized, the scoring rate can be 6000 shots-per-minute when the shot-to-shot dispersion does not exceed 1.2 m.

The ATS-16D consists of the units described below:

1. Control Unit (fig. 5). This unit is usually rack mounted, and placed in a control room from which the firing tests are monitored. This unit contains the preamplifiers and the signal processing, scoring, storage, control, calibration, and interface circuitry.
2. Signal Conditioner Units. These units are mounted at the target area.
3. Rod Sensor Assemblies. These items are placed on the periphery of the target area and are contained within the frame assembly. Eight piezoelectric transducers are mounted on the extreme ends of the dual rod assemblies. Each of these transducers is connected by cables to the inputs of the two signal conditioner units.



Figure 4. Dual rod sensors in both the x- and the y-plane

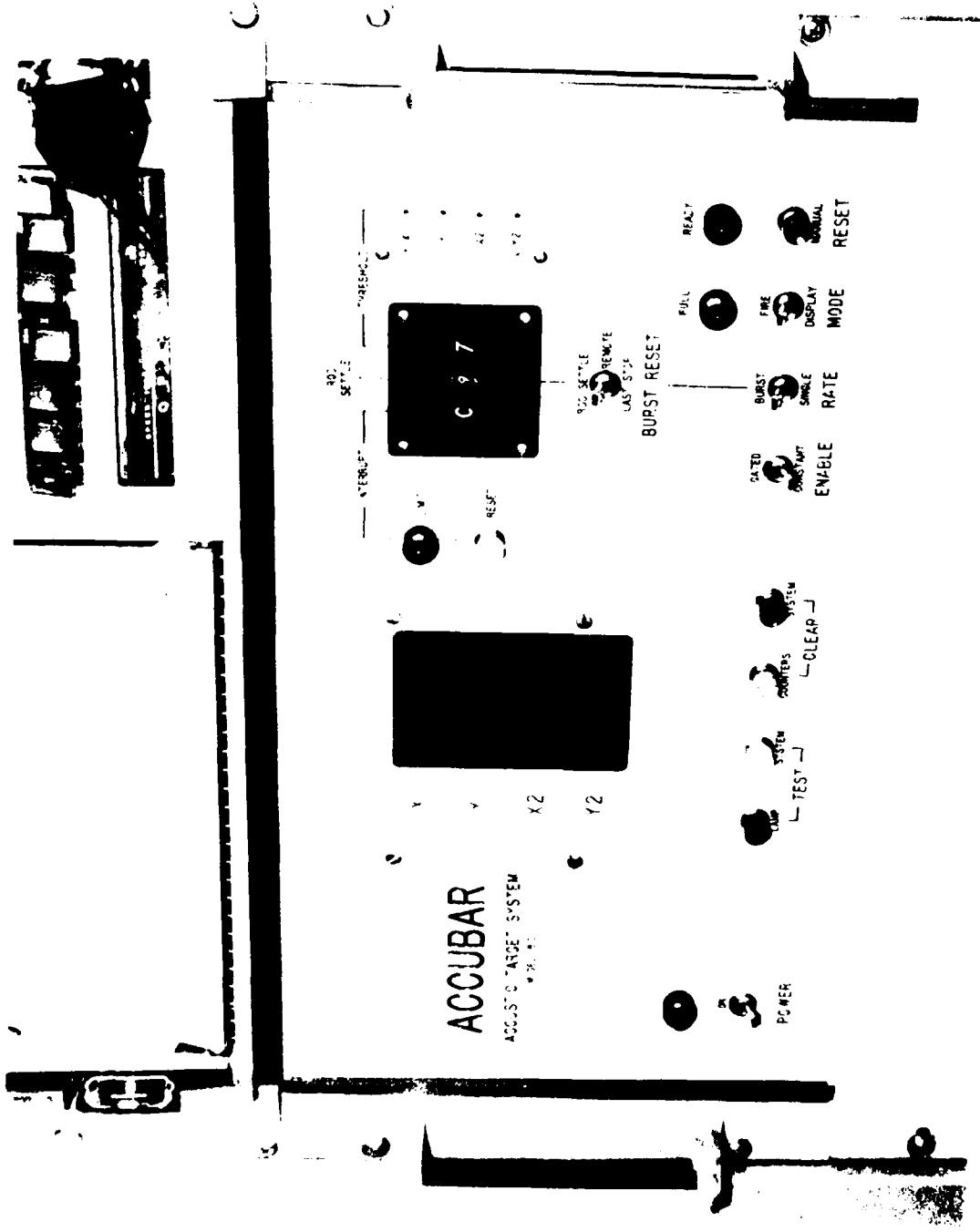

Figure 5. Accubar ATS-16D control unit

4. Frame Assembly. This assembly has acoustic baffles and shockwave apertures and is a self supporting L-shaped framework.

5. Cables. Two main cables and eight transducer cables are used.

SYSTEM FUNCTIONING

The functional block diagram for the ATS-16D is shown in figure 6. The four scoring rods are in the upper left portion of the diagram. Two signal conditioner units (four circuit cards, as shown in fig. 6) receive transducer signals from the rods. To perform the dual-rod, off-axis correction, the ATS-16D requires two rod-sensor assemblies in the x-axis and two rod-sensor assemblies in the y-axis. The signal conditioners provide amplification and impedance-matching circuits to drive the analog signals over the main cable to the preamp and detector cards in the control unit. The electrical test signal, the built-in-test (BIT), is used to excite the plus ends of the rods through the signal conditioners.

In the control unit, the four preamp cards further amplify the analog signals, provide high-pass filtering to eliminate acoustic energy below 20 kHz, and convert the analog signals to digital levels through a zero-crossing detector circuit. The threshold level of detection is controlled on the four cards by the thumbwheel switch located on the front panel. All four levels are adjusted simultaneously; however, individual vernier potentiometers are also provided on the front panel to allow for preamp-to-preamp differences.

The outputs from the preamp cards are in the form of digital signals (start and stop) which contain all the timing information that produces the four rod scores and the timing data. The stream of pulses from the preamp cards is present as long as acoustic energy, above the threshold level, persists in the rods. This activity is monitored through a one-shot retriggerable control, and the lack of activity is used to reset the system under certain setup conditions.

The start and stop pulses from the detectors operate the gate logic to allow the binary coded decimal (BCD) score counters to count the 10.08-MHz score clock. The gate logic also provides the start and stop pulses for the binary time counters, which employ a 10.00-MHz clock. The time counter gates are designed to measure the time [starting with an external pulse (T_0)] from the time a projectile passes a point in space to the time each rod is struck by the shockwave. That is, "first start" in each rod. Because of the physical arrangement of the rods, either x_1 or y_1 will be the first rod struck and will provide the stop pulse for the T_0 gate. The same pulse also starts the T_1 , T_2 , and T_3 gates. The T_1 stop pulse comes from the other x_1 or y_1 rod. The other two gates are stopped by the start pulses from the x_2 and the y_2 rods. The time counter can count a total of approximately 50 msec.

The 4-decade, BCD score-counters have internal latches to store data prior to the shift to memory. Thus, an individual score counter can begin scoring a

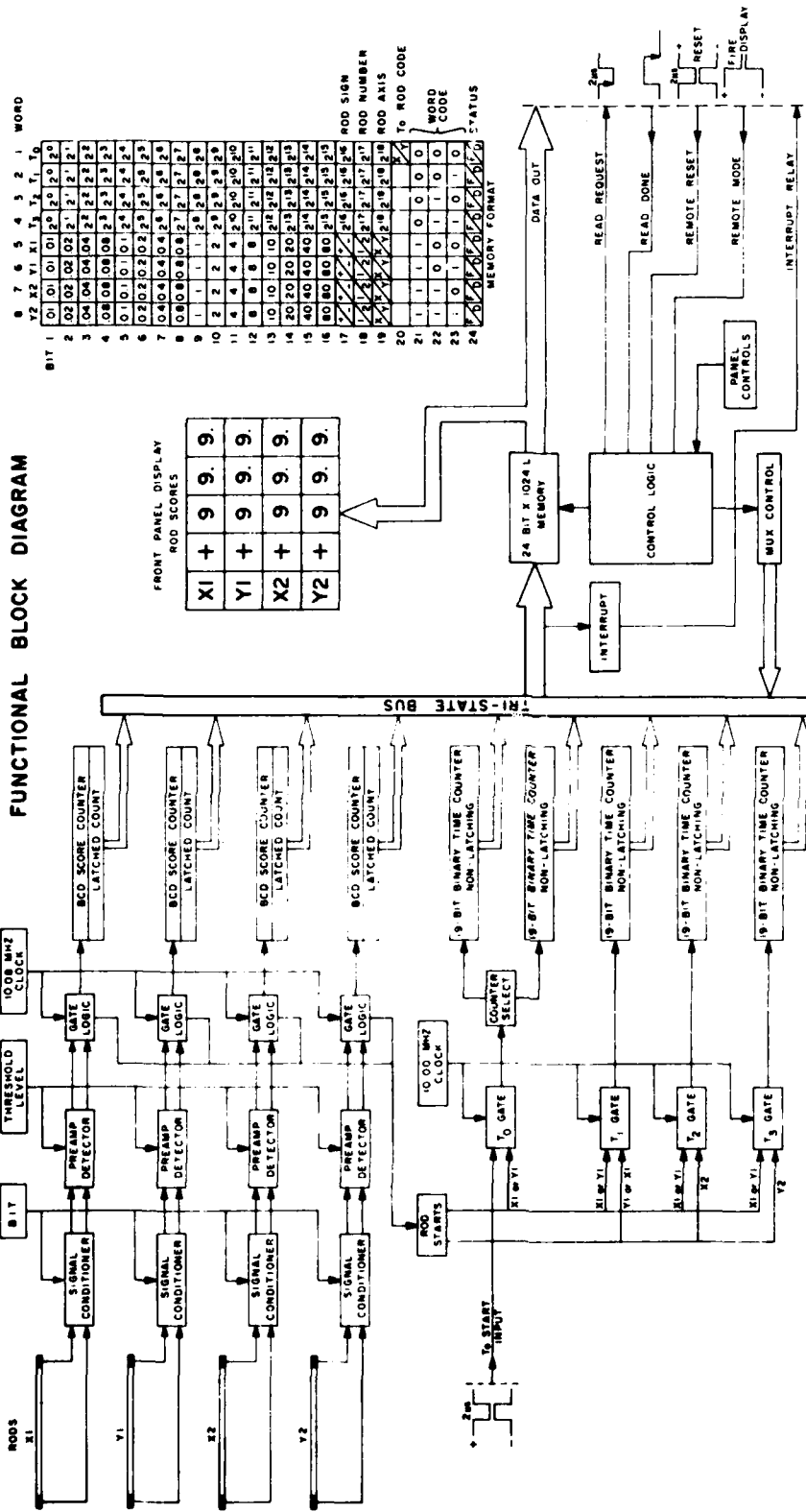

BIT	0	1	2	3	4	5	6	7	8	9	10	11	12	13	14	15	16	17	18	19	20	21	22	23	24
Y2	01	01	01	01	20	20	20	20	20	20	20	20	20	20	20	20	20	20	20	20	20	20	20	20	20
X1	02	02	02	02	21	21	21	21	21	21	21	21	21	21	21	21	21	21	21	21	21	21	21	21	21
Y1	04	04	04	04	22	22	22	22	22	22	22	22	22	22	22	22	22	22	22	22	22	22	22	22	22
X2	08	08	08	08	23	23	23	23	23	23	23	23	23	23	23	23	23	23	23	23	23	23	23	23	23
Y2	10	10	10	10	24	24	24	24	24	24	24	24	24	24	24	24	24	24	24	24	24	24	24	24	24
ROD SIGN	0	0	0	0	1	1	1	1	1	1	1	1	1	1	1	1	1	1	1	1	1	1	1	1	1
ROD NUMBER	0	0	0	0	1	1	1	1	1	1	1	1	1	1	1	1	1	1	1	1	1	1	1	1	1
ROD AXIS	0	0	0	0	1	1	1	1	1	1	1	1	1	1	1	1	1	1	1	1	1	1	1	1	1
TO ROD CODE	0	0	0	0	1	1	1	1	1	1	1	1	1	1	1	1	1	1	1	1	1	1	1	1	1
WORD CODE	0	0	0	0	1	1	1	1	1	1	1	1	1	1	1	1	1	1	1	1	1	1	1	1	1
STATUS	0	0	0	0	1	1	1	1	1	1	1	1	1	1	1	1	1	1	1	1	1	1	1	1	1
MEMORY FORMAT	0	0	0	0	1	1	1	1	1	1	1	1	1	1	1	1	1	1	1	1	1	1	1	1	1

FRONT PANEL DISPLAY
ROD SCORES

X1	+	9	9	9
Y1	+	9	9	9
X2	+	9	9	9
Y2	+	9	9	9

Figure 6. Functional block diagram for ATS-16D

second shot as soon as its rod activity ceases regardless of when the total system is ready for reset. The time counters, however, cannot use latched data because all counters (except T_0) are started simultaneously.

A second start on any counter before a stop (from the previous shot) on that counter would cause confusion in the data, even if latched. To prevent confusing data, a second shot should not begin on the rods until all four rods have been stopped (4th-stop signal) by the preceding shot. The 4th-stop signal is the internal circuit command that starts the shift to memory. A clear command follows the shift sequence to prepare for the next shot. With the system set for last stop, the rods will be able to score at the fastest rate because some rods will be quiet and can begin scoring before others are allowed to reset.

The data for a shot are transferred from the eight counters, through a common bus, to memory. The shift-register type memory holds 128 shots. The 24 bit, 8-word format for each shot is shown in figure 6, with the T_0 data first-in and, thus, first-out. The shift to memory of the eight words is controlled through an external MUX circuit and requires approximately 70 μ sec to complete. The shift can be initiated internally by the ROD SETTLE or LAST STOP logic, externally from a remote source, or manually by use of the front-panel MANUAL RESET switch. As the data are transferred to memory, an interrupt circuit monitors the most significant bit of the x_1 and y_1 scores and compares the value to a preselected limit set on the front panel thumbwheel switch. When the score equals the limit in either rod, a relay is closed to a rear-panel connector and a front-panel light is lit. The relay action does not disable the ATS-16D, but it can be used to stop the firing of the weapon. A pushbutton action on the front panel is required to reset the interrupt circuit.

The ATS-16D can be operated with or without a computer; however, as a standalone unit, the system performs no calculations on the data and can only display scores on the front-panel LED display. With a computer attached, the system can be operated from the front panel or remotely from the computer. After shots are scored and stored in the system, must be switched from FIRE to DISPLAY, since it cannot perform the two functions simultaneously.

The action of switching to DISPLAY causes the data to step rapidly through the shift-register memory until the first word appears on the output. If only one shot is in memory, the shift to output will require approximately 8 msec. When in SINGLE rate and controlled from the front panel, each push of the MANUAL RESET pushbutton shifts one word out to display. Eight pushes are required to fully display the scores for one shot. With a computer controlling the data output, the rate-of-transfer will be determined by the computer and by the 8-msec shift-time in the system.

When the computer connection is made through the rear panel data connector, the front-panel MODE Switch (FIRE or DISPLAY) and the RESET pushbutton are disabled. The other switches remain active and, in fact, must be used to initiate the target system at the beginning of a test sequence. Such functions as SYSTEM CLEAR, SYSTEM TEST (BIT), RATE, etc., can only be performed through the front panel. A detailed description of individual circuits is shown in chapter 3 of reference 2.

ACCEPTANCE TESTING

The acceptance test of the ATS-16D consisted of firing projectiles at a paper target and comparing the impact points to those recorded by the system. The paper targets were positioned at various locations in the Accubar target plane. The x-y coordinates of the bullseye of the paper target were referenced to the center of the target area.

Targets were obtained by the firing of 5.56-mm, 7.62-mm, 0.50 caliber, and 20-mm ammunition. Burst firings of 20-mm ammunition could not be automatically scored because shockwave reflections from the concrete floor and walls caused false triggering of the ATS-16D.

For data analysis the difference was determined between the ATS-16D coordinates and the measured coordinates from the paper target for the same round. The 5.56-mm and 7.62-mm data were grouped (targets A through J), as were the 0.50 caliber and 20-mm single-shot data (targets K through U).

The algebraic difference between scoring by the ATS-16D and the measured paper targets for each of the impact points for targets A through J, for the combined targets with 5.56-mm and 7.62-mm ammunition is shown in table 1.

The mean, the standard deviation, and the variance were calculated according to

$$\text{Mean: } \bar{x} = \frac{\sum_{i=1}^n x_i}{n}$$

$$\text{Standard deviation: } \sigma_{(n-1)} = \sqrt{\frac{\sum_{i=1}^n (x_i - \bar{x})^2}{n-1}}$$

$$\text{Variance: } \text{Var}_{(n-1)} = \frac{\sum_{i=1}^n (x_i - \bar{x})^2}{n-1} = \sigma_{(n-1)}^2$$

Substitution of the values of table 1 into the above equation yields

Mean	= 0.0157 cm
Standard Deviation	= 0.156 cm
Variance	= 0.0243 cm

The standard deviation is shown in table 2. In all cases, the standard deviation is less than the 0.65 cm specified by the contract with Accubar engineering. The largest standard deviation is 0.2293 cm calculated for the x₂ coordinate with the 5.56-mm and 7.62-mm projectiles. Because all values of the standard deviation are less than the accuracy requirement², the ATS-16D was judged acceptable for use by the Ware Simulation Section.

Table 1. Algebraic difference between scoring by ATS-16D measured paper targets for 5.56-mm ammunition (targets A through J)

<u>Round</u>	<u>A</u>	<u>B</u>	<u>C</u>	<u>D</u>	<u>E</u>	<u>F</u>	<u>H</u>	<u>I</u>	<u>J</u>
1	-0.25	-0.76	0	-0.25	0.25	0	0.50	0.25	0.25
2	-0.25	-0.25	0	-0.25	0.50	0.50	0.50	0	0
3	0.76	-0.25	0.50	0.25	-0.76	-0.76	0.25	0	-0.25
4	0	0.50	-0.25	0.25	0.76	-0.25	-0.25	0	-0.25
5	0.25	1.0	0	-0.76	0.25	0.25	-0.25	0	0.25
6	0.76	-0.50	-0.50	0	0	0.50	0.50	0.25	0
7	-0.25	0.25	-0.50	0.25	0.50	-0.50	-0.50	-0.76	0
8	-0.25	-0.50	0.25	0.50	0.25	-0.25	-0.25	0.50	0
9	0	0.25	0.25	0.25	0	0.76	0	0.50	0
10	0.25	0	0	-0.50	0.50	0.50	0	0	
11		0					0		

Table 2. Variances and standard deviations for acceptance testing

<u>Targets</u>	<u>Coordinate</u>	<u>Rounds fired</u>	<u>Variance $S^2(n-1)$ (cm)</u>	<u>Standard deviation (cm)</u>
A through J (5.56- and 7.62-mm)	x ₁	89	0.0243	0.1559
	x ₂	89	0.0526	0.2293
	y ₁	89	0.0353	0.1880
	y ₂	89	0.0306	0.1748
K through U (0.50 caliber and 20-mm)	x ₁	56	0.0217	0.1473
	x ₂	56	0.0509	0.2255
	y ₁	54	0.0249	0.1579
	y ₂	55	0.0327	0.1810

The acceptance test of the ATS-16D showed that the system operated satisfactorily for the 5.56-mm and 7.62-mm ammunition. However, for burst-firing of 20-mm and larger ammunition, baffles must be installed on the range walls and floor. The baffles must absorb and/or break up the shockwaves that are reflected off the walls and floor. These reflected shockwaves, if not absorbed, would cause false triggering of the acoustic targeting system and would give false readings.

CONCLUSIONS

The following conclusions are made:

1. The system worked well for 5.56-mm and 7.62-mm projectiles. However, for satisfactory use during burst-firing of 20-mm and longer ammunition, baffles must be installed on the concrete walls, floor, and ceiling of the range to absorb or break up the reflected shockwaves that would cause false triggering of the ATS-16D system.

2. The ATS-16D system will become much more versatile when it is interfaced with a computer. This procedure will allow the manipulating of the raw target into statistical targeting parameters such as circular error, etc. It is anticipated that the present computer at the Ware Simulation Section will be replaced within the next year with one having a much larger memory.

RECOMMENDATIONS

The following recommendations are made:

1. Use the ATS-16D system with the six-degree-of-freedom simulator.
2. Provide the ranges with baffles to allow the use of the ATS-16D system for the automatic cannon caliber weapons systems.
3. Integrate the ATS-16D system with the larger memory computer to be installed at the Ware Simulation Section.

REFERENCES

1. Systems Consultants, Inc., "Automatic Target Scoring Device," Final Technical Report, Washington, DC, 1977.
2. Accubar Engineering, "Operation and Maintenance Manual, M16D, Acoustic Target System, Model ATS-16D", Alexandria, PA, 1978.

PROCEEDING PAGE BLANK-NOT FILMED

DISTRIBUTION LIST

Administrator
Defense Technical Information Center
ATTN: Accessions Division (12)
Cameron Station
Alexandria, VA 22314

Department of the Army
Program Manager for
Fighting Vehicle Systems
ATTN: DRCPM-FVS
DRCPM-FVS-SE
Warren, MI 48090

Commander
U.S. Army Armament Research and
Development Command
ATTN: DRDAR-SC
DRDAR-SCS (2)
DRDAR-SCA (4)
DRDAR-SCF (2)
DRDAR-TSE-E (3)
DRDAR-TSS (5)
DRDAR-GCI
Dover, NJ 07801

Commander
U.S. Army Armament Materiel
Readiness Command
ATTN: DRSAR-ASR (2)
DRSAR-IEI
DRSAR-IEP-L
DRSAR-QAI
Rock Island, IL 61299

Commander
U.S. Army Armament Research and
Development Command
ATTN: DRDAR-TSE-SW (10)
Rock Island, IL 61299

Commander
Rock Island Arsenal
ATTN: SARRI-EN
SARRI-ADM (2)
Rock Island, IL 61299

REVERSING PAGE BLANK-NOT FILMED

Director
U.S. Army Industrial Base
Engineering Activity
ATTN: DRXIB-MT
Rock Island Arsenal
Rock Island, IL 61299

Comamnder
Jefferson Proving Ground
ATTN: STEJY-TD
Madison, IN 47250

Commander/Director
Chemical Systems Laboratory
U.S. Army Armament Research and
Development Command
ATTN: DRDAR-CLJ-L
DRDAR-CLB-PA
APG, Edgewood Area, MD 21010

Director
Ballistics Research Laboratory
U.S. Army Armament Research and
Development Command
ATTN: DRDAR-TSB-S
Aberdeen Proving Ground, MD 21005

Chief
Benet Weapons Laboratory, LCWSL
U.S. Army Armament Research and
Development Command
ATTN: DRDAR-LCB-TL
Watervliet, NY 12189

Director
U.S. Army TRADOC Systems
Analysis Activity
ATTN: ATAA-SL
White Sands Missile Range, NM 88002

Director
U.S. Army Materiel Systems
Analysis Activity
ATTN: DRXSY-MP
Aberdeen Proving Ground, MD 21005

Project Manager Cobra
ATTN: DRCPM-CO-TM
4300 Goodfellow Boulevard
St. Louis, MO 63120

Program Manager
Advanced Attack Helicopter
ATTN: DRCPM-AAH-TM
4300 Goodfellow Boulevard
St. Louis, MO 63120

Commander
U.S. Army Materials and Mechanics
Research Center
ATTN: DRXMR-MQ
Watertown, MA 02172

DATE
ILME