

AD-A108 540

PENNSYLVANIA STATE UNIV UNIVERSITY PARK APPLIED RESE--ETC F/8 20/1
EFFECT OF AIR CONTENT ON BROADBAND NOISE MEASUREMENTS IN THE 1.--ETC(U)
AUG 81 B E ROBBINS, D E THOMPSON N00024-79-C-6043

UNCLASSIFIED

ARL/PSU/TH-81-166

NL

In 1
2/8/80



END
DATE
FILMED
4-82
DTIC

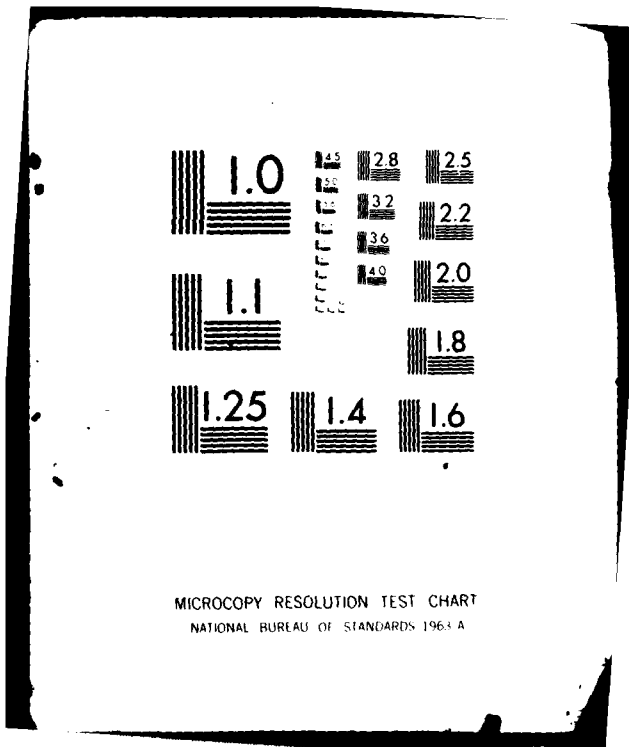

1.0

1.1

1.25

1.5
1.55
1.6
1.65
1.7
1.75
1.8

2.8

3.2

3.6

4.0

2.5

2.2

2.0

1.8

1.4

1.6

MICROCOPY RESOLUTION TEST CHART
NATIONAL BUREAU OF STANDARDS 1963-A

LEVEL

6

AD A108540

EFFECT OF AIR CONTENT ON BROADBAND NOISE MEASUREMENTS IN THE 1.22-m DIAMETER WATER TUNNEL

B. E. Robbins and D. E. Thompson

SDTIC
ELECTED
DEC 10 1981
H

Technical Memorandum
File No. 81-166
11 August 1981
Contract No. N00024-79-C-6043

Copy No. 19

The Pennsylvania State University
APPLIED RESEARCH LABORATORY
Post Office Box 30
State College, PA 16801

Approved for Public Release
Distribution Unlimited

NAVY DEPARTMENT

NAVAL SEA SYSTEMS COMMAND

DTIC FILE COPY

81 12 08 097

REPORT DOCUMENTATION PAGE		READ INSTRUCTIONS BEFORE COMPLETING FORM
1. REPORT NUMBER TM-81-166	2. GOVT ACCESSION NO. AD-A108 540	3. RECIPIENT'S CATALOG NUMBER
4. TITLE (and Subtitle) EFFECT OF AIR CONTENT ON BROADBAND NOISE MEASUREMENTS IN THE 1.22-m DIAMETER WATER TUNNEL		5. TYPE OF REPORT & PERIOD COVERED Technical Memorandum
		6. PERFORMING ORG. REPORT NUMBER
7. AUTHOR(s) B. E. Robbins and D. E. Thompson		8. CONTRACT OR GRANT NUMBER(s) N00024-79-C-6043
9. PERFORMING ORGANIZATION NAME AND ADDRESS Applied Research Laboratory Post Office Box 30 State College, PA 16801		10. PROGRAM ELEMENT, PROJECT, TASK AREA & WORK UNIT NUMBERS
11. CONTROLLING OFFICE NAME AND ADDRESS Naval Sea Systems Command Department of the Navy Washington, DC 20362		12. REPORT DATE 11 August 1981
		13. NUMBER OF PAGES 15
14. MONITORING AGENCY NAME & ADDRESS (if different from Controlling Office)		15. SECURITY CLASS. (of this report) UNCLASSIFIED
		15a. DECLASSIFICATION/DOWNGRADING SCHEDULE
16. DISTRIBUTION STATEMENT (of this Report) Approved for public release. Distribution unlimited Per NAVSEA - November 17, 1981.		
17. DISTRIBUTION STATEMENT (of the abstract entered in Block 20, if different from Report)		
18. SUPPLEMENTARY NOTES		
19. KEY WORDS (Continue on reverse side if necessary and identify by block number) water tunnel, broadband, radiated noise, measurements, air		
20. ABSTRACT (Continue on reverse side if necessary and identify by block number) The effect of air content on broadband radiated noise in the 1.22-m diameter water tunnel was investigated. In addition, tunnel operating pressure was also varied. The transmitting hydrophone was positioned in the tail of an axisymmetric body mounted in the test section. Two receiving transducers were used. Both showed a somewhat systematic change in broadband spectral levels with variations in air content up to 11 parts per million and variations in pressure.		

Subject: Effect of Air Content on Broadband Noise Measurements
in the 1.22-m Diameter Water Tunnel

Abstract: The effect of air content on broadband radiated noise in the 1.22-m diameter water tunnel was investigated. In addition, tunnel operating pressure was also varied. The transmitting hydrophone was positioned in the tail of an axisymmetric body mounted in the test section. Two receiving transducers were used. Both showed a somewhat systematic change in broadband spectral levels with variations in air content up to 11 parts per million and variations in pressure.

Acknowledgment: This work was supported by the Naval Sea Systems Command, Code NSEA-05H.

Accession	
NOIS	
DTIC I	
Unann	
Jan 19	
By	
Distrib	
Dist	
A	

Table of Contents

	<u>Page</u>
Abstract	1
Acknowledgment	1
List of Figures	3
INTRODUCTION	4
INSTRUMENTATION	4
TEST PROCEDURE	4
RESULTS	5
CONCLUSIONS	5
RECOMMENDATIONS	5
Figures	6

List of Figures

<u>Figure No.</u>	<u>Title</u>	<u>Page</u>
1	Model Installation and Instrumentation	6
2	Schematic of Instrumentation Setup	7
3	Broadband Noise Spectra at Various Air Contents: Inflow Sensor, Flow Velocity 6.1 m/sec, Tunnel Pressure 241.325 KPa	8
4	Broadband Noise Spectra at Various Air Contents: Inflow Sensor, Flow Velocity 10.7 m/sec, Tunnel Pressure 241.325 KPa	9
5	Broadband Noise Spectra at Various Air Contents: Downstream Array, Flow Velocity 6.1 m/sec, Tunnel Pressure 241.325 KPa	10
6	Broadband Noise Spectra at Various Air Contents: Downstream Array, Flow Velocity 10.7 m/sec, Tunnel Pressure 241.325 KPa	11
7	Broadband Noise at 75 kHz Versus Air Content at Various Tunnel Pressures: Inflow Sensor, Flow Velocity 6.1 m/sec .	12
8	Broadband Noise at 75 kHz Versus Air Content at Various Tunnel Pressures: Inflow Sensor, Flow Velocity 10.7 m/sec .	13
9	Broadband Noise at 105 kHz Versus Air Content at Various Tunnel Pressures: Downstream Array, Flow Velocity 6.1 m/sec	14
10	Broadband Noise at 105 kHz Versus Air Content at Various Tunnel Pressures: Downstream Array, Flow Velocity 10.7 m/sec	15

INTRODUCTION

An experimental study was conducted in the 1.22-m diameter water tunnel to determine the effects of air content on measured broadband noise. A single transmitting hydrophone and two receiving transducers were used in the test. The air content, static tunnel pressure, and flow velocity were varied for these measurements.

The purpose of this study was to determine the effects of the air content on the sound transmission in the water tunnel. The results and conclusions of this study are presented in this report.

INSTRUMENTATION

The transmitting hydrophone was installed in the tail of an axisymmetric body which was mounted in the test section of the 1.22-m diameter Garfield Thomas Water Tunnel of the Applied Research Laboratory at The Pennsylvania State University. The inflow hydrophone and downstream array were mounted in the water tunnel as shown in Figure 1. An LC-32 hydrophone was used as the transmitter. It was encased in a plexiglass tailcone which was virtually acoustically transparent in the water medium. This plexiglass covering's exterior surface matched the contour of the vehicle's tail section and replaced the propeller hub and spinner. The electrical connections were brought forward in the test body and out through its support strut.

The inflow hydrophone and downstream array were mounted at their normal tunnel positions, see Figure 1. A block diagram of the transmitting and receiving circuits is shown in Figure 2. A General Radio white noise generator produced the input to the LC-32 which transmitted it into the environment. The input rms voltage was monitored on a voltmeter. The received signals were amplified and then analyzed on a Spectral Dynamics (SD) 360 real time analyzer. Data analysis was performed in the 0 to 150 kHz range. The data were reduced in the same manner as in a standard acoustic measurement test. In each of the spectral analyses an antialiasing filter set at 20% below the upper frequency, part of the SD 360 system, was employed. Also, a high pass Khronhite filter, set at 25 kHz, was used.

TEST PROCEDURE

As the conclusion of the previous test in the water tunnel the air content had risen to 10.99 parts per million (ppm). During the present study, the water was partially deaerated between measurements to control the air content. The tunnel flow velocity was maintained at 6.1 m/sec and tunnel pressure held constant at 137.9 KPa while a water sample was taken and analyzed for its air content.

Acoustic spectra were obtained while the tunnel was operated at two flow velocities, 6.1 and 10.7 m/sec. At each velocity, the tunnel pressure was set to the following values: 137.9, 172.375, 206.85, and 241.325 KPa.

RESULTS

The results obtained are shown in Figures 3 through 10. Figures 3 through 6 show broadband noise spectra at different air contents while under constant operating conditions. Both sensors exhibited the same spread in the data. The spectra in Figures 5 and 6 had a high pass filter set at 40 kHz, which cutoff everything below that frequency. Each spectra has two distinct characteristics. At low frequencies (below about 75 kHz) air content has no effect on spectral level. At the higher frequencies the higher the air content the lower the spectral level. The maximum spread in the data was about 6.0 dB over the air content range of 3.1 to 10.99 ppm. Figures 3 and 4 showed that tunnel flow velocity variations had no effect on the spectra from the inflow sensor.

Figures 7 through 10 are cross plots of the spectral values at 75 kHz for the inflow sensor and 105 kHz for the downstream array plotted against the air content at various tunnel pressures. By holding the tunnel pressure constant at 137.9 KPa, the higher the air content the lower the spectral levels. The maximum variation in spectral level was no more than 6 dB; except at the highest air content which showed a 10 dB variation.

CONCLUSIONS

Based on the results the following conclusions can be drawn:

Below about 75 kHz, air content and pressure have no effect on sound transmission.

A general trend exists at frequencies at and above 75 kHz where the attenuation increases as the air content increases.

A general trend exists at frequencies at and above 75 kHz where the attenuation increases as the pressure decreases.

RECOMMENDATIONS

The narrowband analysis employed in the present investigation was not sufficient to allow a good definition of the trends of attenuation with air content and pressure. A repeat test should be conducted using 1/3 octave band analysis or greater so that exact variations can be established and subsequently applied to measured data.

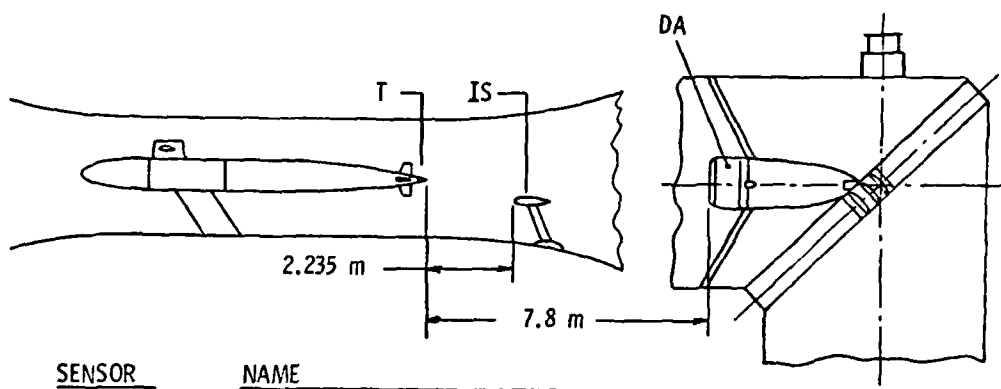

<u>SENSOR</u>	<u>NAME</u>
DA	DOWNSTREAM ARRAY
IS	INFLOW SENSOR
T	LC-32 TRANSMITTING HYDROPHONE

Figure 1. Model Installation and Instrumentation

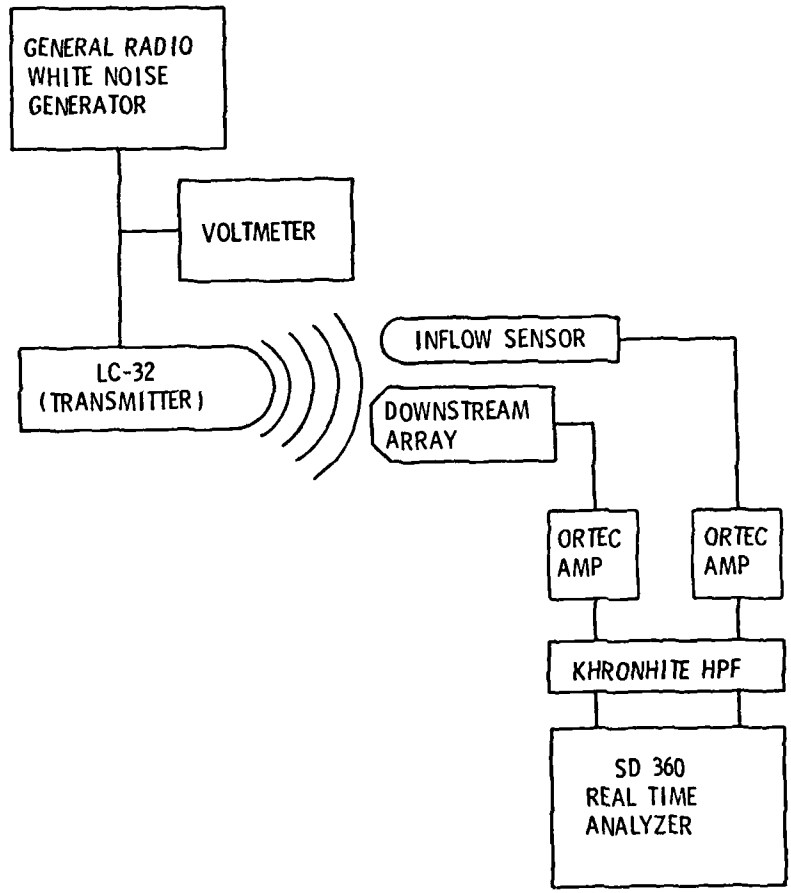

Figure 2. Schematic of Instrumentation Setup

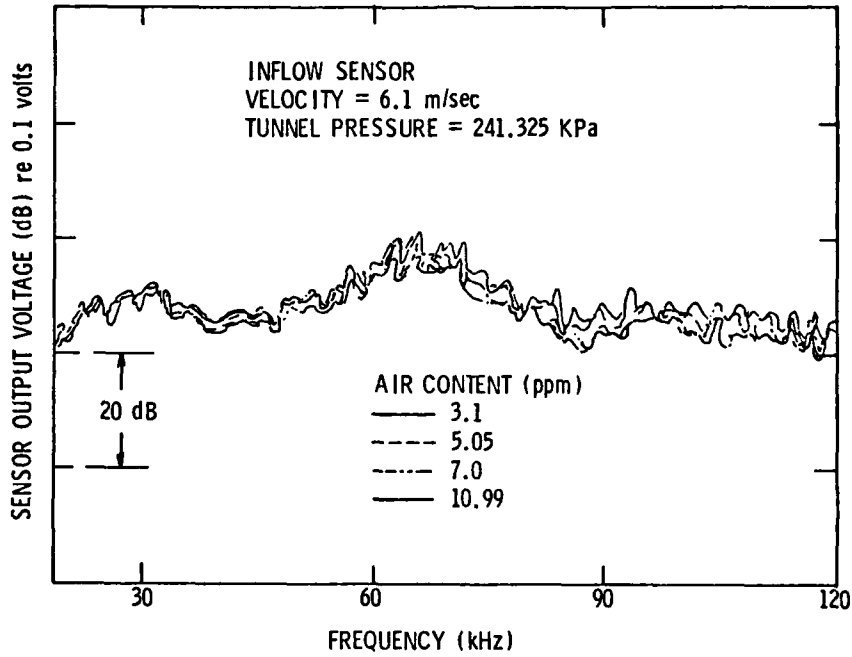

Figure 3. Broadband Noise Spectra at Various Air Contents: Inflow Sensor, Flow Velocity 6.1 m/sec, Tunnel Pressure 241.325 KPa

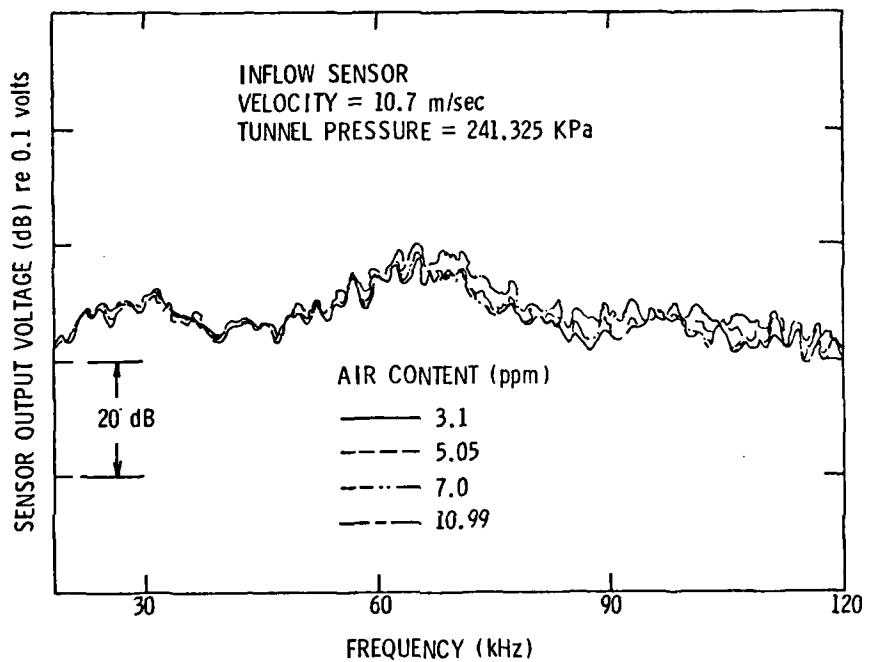

Figure 4. Broadband Noise Spectra at Various Air Contents: Inflow Sensor, Flow Velocity 10.7 m/sec, Tunnel Pressure 241.325 KPa

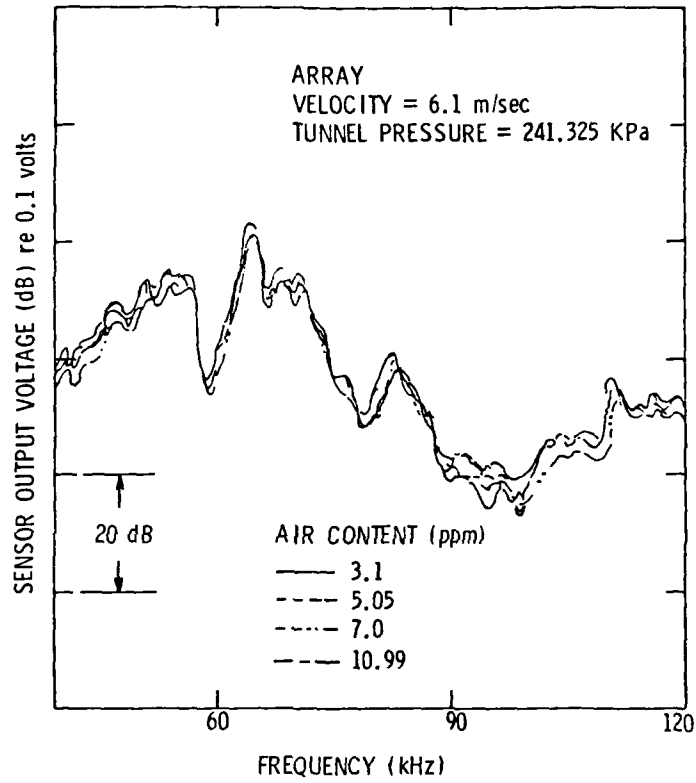

Figure 5. Broadband Noise Spectra at Various Air Contents: Downstream Array, Flow Velocity 6.1 m/sec, Tunnel Pressure 241.325 KPa

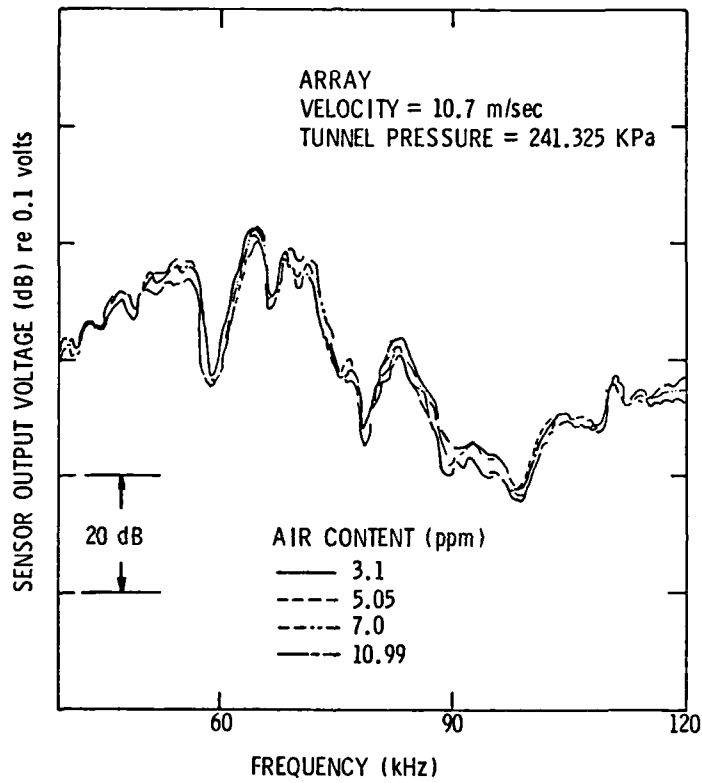

Figure 6. Broadband Noise Spectra at Various Air Contents: Downstream Array, Flow Velocity 10.7 m/sec, Tunnel Pressure 241.325 KPa

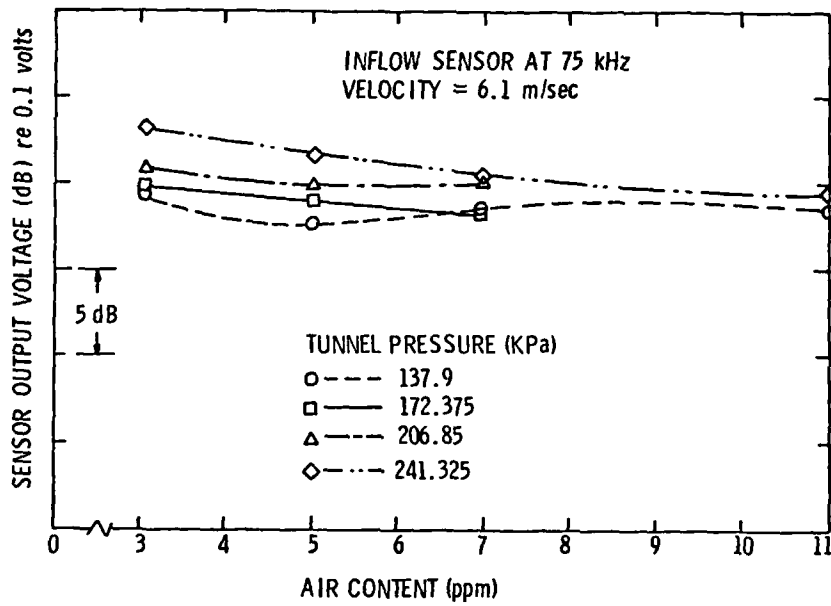

Figure 7. Broadband Noise at 75 kHz Versus Air Content at Various Tunnel Pressures: Inflow Sensor, Flow Velocity 6.1 m/sec

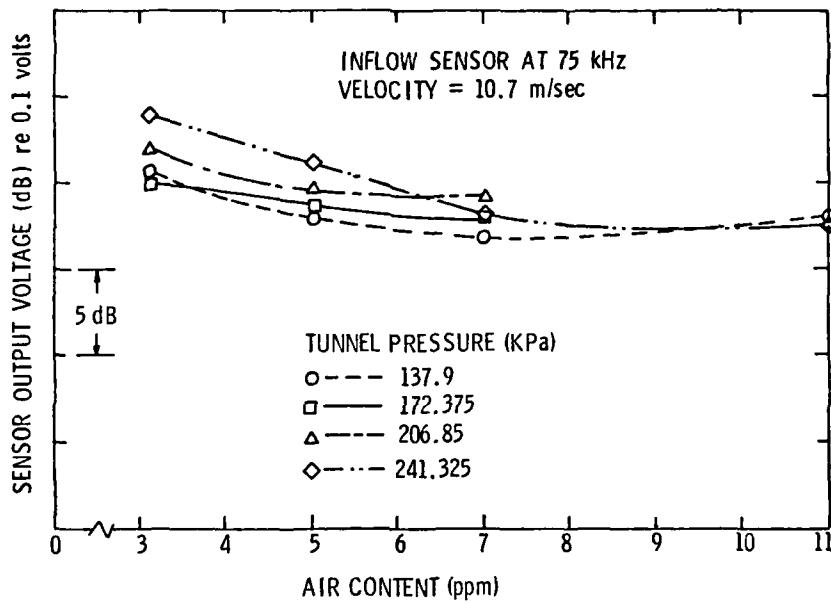

Figure 8. Broadband Noise at 75 kHz Versus Air Content at Various Tunnel Pressures: Inflow Sensor, Flow Velocity 10.7 m/sec

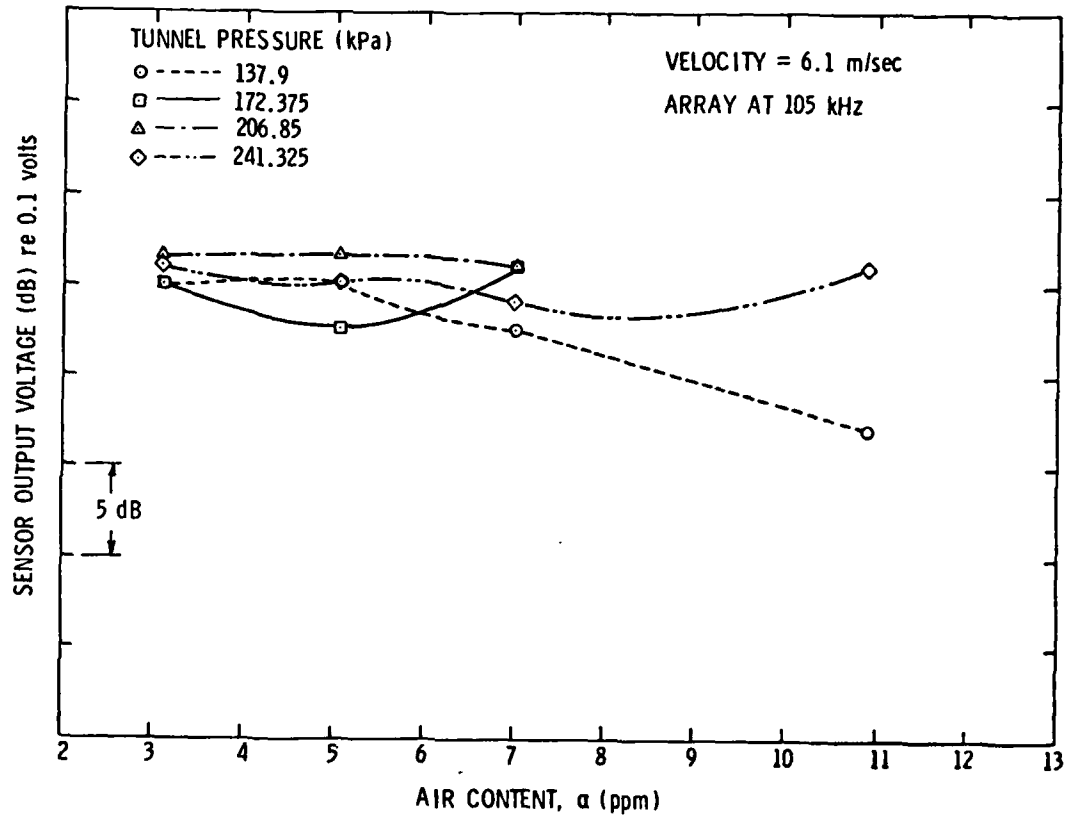

Figure 9. Broadband Noise at 105 kHz Versus Air Content at Various Tunnel Pressures: Downstream Array, Flow Velocity 6.1 m/sec

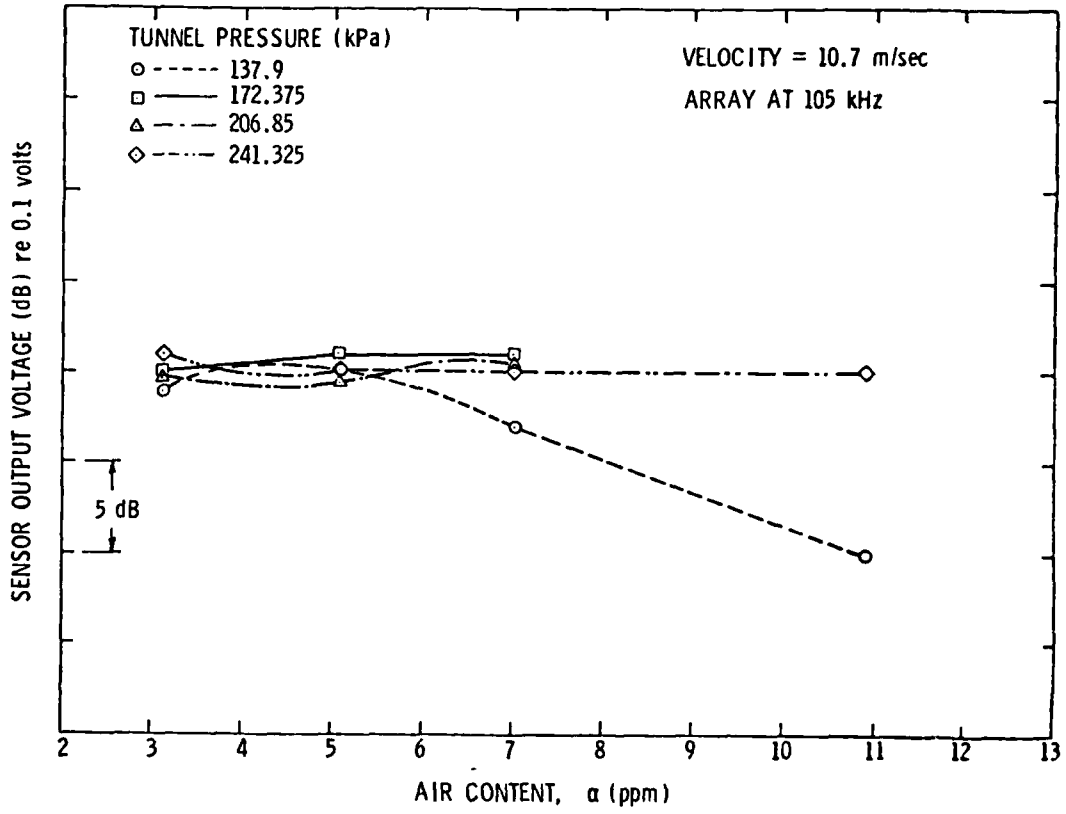

Figure 10. Broadband Noise at 105 kHz Versus Air Content at Various Tunnel Pressures: Downstream Array, Flow Velocity 10.7 m/sec

DISTRIBUTION LIST FOR ARL UNCLASSIFIED TM 81-166 by B. E. Robbins and
D. E. Thompson, dated 11 August 1981.

Commander
Naval Sea Systems Command
Department of the Navy
Washington, DC 20362
Attn: Library
Code NSEA-09G32
(Copy Nos. 1 and 2)

Naval Sea Systems Command
Attn: F. E. Eissing
Code NSEA-05H
(Copy No. 3)

Naval Sea Systems Command
Attn: A. R. Paladino
Code NSEA-05H1
(Copy No. 4)

Naval Sea Systems Command
Attn: F. B. Peterson
Code NSEA-52P
(Copy No. 5)

Naval Sea Systems Command
Attn: R. Taddeo
Code NSEA-5212
(Copy No. 6)

Naval Sea Systems Command
Attn: T. E. Peirce
Code NSEA-63R3
(Copy No. 7)

Naval Sea Systems Command
Attn: C. R. Crockett
Code NSEA-5212
(Copy No. 8)

Naval Sea Systems Command
Attn: W. L. Louis
Code NSEA-32132
(Copy No. 9)

Commander
David W. Taylor Naval Ship R&D Center
Department of the Navy
Bethesda, MD 20084
Attn: W. K. Blake
Code 1905
(Copy No. 10)

David W. Taylor Naval Ship R&D Center
Attn: T. E. Brackett
Code 1544
(Copy No. 11)

David W. Taylor Naval Ship R&D Center
Attn: F. S. Archibald
Code 1942
(Copy No. 12)

David W. Taylor Naval Ship R&D Center
Attn: J. H. McCarthy
Code 154
(Copy No. 13)

David W. Taylor Naval Ship R&D Center
Attn: R. Boswell
Code 1544
(Copy No. 14)

David W. Taylor Naval Ship R&D Center
Attn: D. Vendittis
Code 1926
(Copy No. 15)

David W. Taylor Naval Ship R&D Center
Attn: W. B. Morgan
Code 15
(Copy No. 16)

David W. Taylor Naval Ship R&D Center
Attn: M. M. Sevik
Code 19
(Copy No. 17)

David W. Taylor Naval Ship R&D Center
Attn: J. Shen
Code 194
(Copy No. 18)

Defense Technical Information Center
5010 Duke Street
Cameron Station
Alexandria, VA 22314
(Copy Nos. 19 to 24)

The Pennsylvania State University
Applied Research Laboratory
Post Office Box 30
State College, PA 16801
Attn: B. E. Robbins
(Copy No. 25)

DISTRIBUTION LIST FOR ARL UNCLASSIFIED TM 81-166 by B. E. Robbins and
D. E. Thompson, dated 11 August 1981.

Applied Research Laboratory
Attn: G. C. Lauchle
(Copy No. 26)

Applied Research Laboratory
Attn: D. E. Thompson
(Copy No. 27)

Applied Research Laboratory
Attn: W. S. Gearhart
(Copy No. 28)

Applied Research Laboratory
Attn: E. G. Taschuk
(Copy No. 29)

Applied Research Laboratory
Attn: GTWT Files
(Copy No. 30)

