

AD-A108 657

MASSACHUSETTS INST OF TECH CAMBRIDGE DEPT OF PHYSICS

F/G 7/4

ELECTRON ENERGY LOSS SPECTROSCOPY OF GALLIUM ARSENIDE AND OTHER--ETC(U)

NOV 81 M H WEILER

F49620-79-C-0176

NL

UNCLASSIFIED

AFOSR-TR-81-0800

1-1
1-1



END
DATE
FBI
1-82
DTC

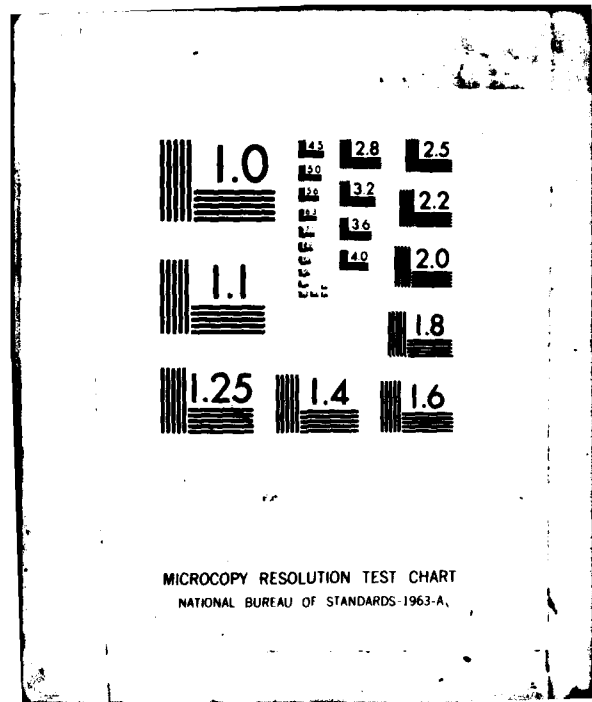

AFOSR-TR- 81 - 0800

LEVEL

4

16

AD A108657

ANNUAL PROGRESS REPORT

July 1, 1980 - June 30, 1981

on

F49620-79C-0176

ELECTRON ENERGY LOSS SPECTROSCOPY
OF GALLIUM ARSENIDE AND OTHER MATERIALS

Submitted to

AIR FORCE OFFICE OF SCIENTIFIC RESEARCH

by

Department of Physics

Massachusetts Institute of Technology

Cambridge, Massachusetts 02139

DTIC
SELECTED
DEC 15 1981

Principal Investigator:

Margaret H. Weller
Assistant Professor
Department of Physics
Room 13-2145
Tel: (617) 253-4822

DTIC FILE COPY

Approved for public release;
distribution unlimited.

402735 81 12 14 061

UNCLASSIFIED REPORT DOCUMENTATION PAGE		READ INSTRUCTIONS BEFORE USING THIS FORM
1. REPORT NUMBER AFOSR-TR- 81-0800	2. GOVT ACCESSION NO. AD-A108	3. REPORT/CATALOG NUMBER 657
4. TITLE (and Subtitle) ELECTRON ENERGY LOSS SPECTROSCOPY OF GALLIUM ARSENIDE AND OTHER MATERIALS		5. TYPE OF REPORT & PERIOD COVERED Annual Report July 1, 1980-June 30, 1981
7. AUTHOR(s) Margaret H. Weiler		6. PERFORMING ORG. REPORT NUMBER
9. PERFORMING ORGANIZATION NAME AND ADDRESS Massachusetts Institute of Technology 77 Massachusetts Avenue Cambridge, MA 02139		8. CONTRACT OR GRANT NUMBER(s) F49620-79-C-0176
11. CONTROLLING OFFICE NAME AND ADDRESS Air Force Office of Scientific Research/NE BLDG 410 Bolling AFB, DC 20332		10. PROGRAM ELEMENT, PROJECT, TASK AREA & WORK UNIT NUMBERS 61102F 2306/B2
14. MONITORING AGENCY NAME & ADDRESS (if different from Controlling Office)		12. REPORT DATE November 10, 1981
		13. NUMBER OF PAGES 15
		15. SECURITY CLASS. (of this report) UNCLASSIFIED
		15a. DECLASSIFICATION DOWNGRADING SCHEDULE
16. DISTRIBUTION STATEMENT (of this Report) APPROVED FOR PUBLIC RELEASE; DISTRIBUTION UNLIMITED		
17. DISTRIBUTION STATEMENT (of the abstract entered in Block 20, if different from Report)		
18. SUPPLEMENTARY NOTES		
19. KEY WORDS (Continue on reverse side if necessary and identify by block number) Electron energy loss spectroscopy; electron scattering; experimental band structure determination; semiconductors; gallium arsenide.		
20. ABSTRACT (Continue on reverse side if necessary and identify by block number) → This report describes the construction and testing of a new electron energy loss spectrometer to study the band structure of GaAs and other materials using the inelastic scattering of 230keV electrons. — to p. 1		

DD FORM 1 JAN 73 1473

UNCLASSIFIED

SECURITY CLASSIFICATION OF THIS PAGE (When Data Entered)

I. INTRODUCTION

In the past year, substantial progress has been made towards the realization of a working experiment in high-energy electron energy loss spectroscopy, with which to study the electronic states in GaAs and other materials. At the end of the previous year we had nearly completed construction of the major components of the apparatus, although several components had not yet been tested. In the past year we have completed construction, tested all the components, and corrected a number of problems some of which caused a significant delay in getting the experiment started. Now, as is discussed below, we believe that we have solved the major problems and will have a working apparatus in the near future.

In the following sections we give details of our progress in the major components of the project: electron optics, electronics, high-voltage terminal, sample preparation, and data reduction. Figs. 1-3 give diagrams of the apparatus and electronics.

Accession For	
NTIS GRA&I	<input checked="" type="checkbox"/>
DTIC TAB	<input type="checkbox"/>
Unannounced	<input type="checkbox"/>
Justification	
By _____	
Distribution/	
Availability Codes	
Dist	Special
A	

AIR FORCE OFFICE OF SCIENTIFIC RESEARCH (AFOSR)
NOTICE OF TRANSMITTAL TO DTIC
This technical report has been reviewed and is
approved for public release IAW AFR 199-12.
Distribution is unlimited.
MATTHEW J. KERPER
Chief, Technical Information Division

II. ELECTRON OPTICS

At the end of the first year, the electron optics systems were ready for re-assembly after correction of a number of defects in the original machining. These were re-assembled, inserted in the vacuum chamber and, after completion of the power supply, testing began using the design lens voltages. We quickly began having problems of breakdown between adjacent lens elements, either across the gap or along the insulating rods and sapphire balls. A good portion of this past year has been spent correcting these problems.

One source of difficulty was the Electrodag which was used to coat the inner surfaces of the lens elements and hemispheres. Particles of carbon flaked off and lodged between two lens elements, providing a conducting path. Traces of the coating along the insulating rods which thread through all the elements, and on the sapphire balls which separate and position them, also provided conducting paths and proved very difficult to clean off.

We found a major improvement when we completely dis-assembled the monochromator and analyzer and machined all the elements to increase the gaps between adjacent elements. It also proved very helpful to clean the Electrodag coating from all the lens elements. We did leave the hemispheres coated, since these surfaces are more critical. The alumina rods, which developed tracks along them, were replaced with tubes of thermalfilm insulating material, wrapped around the screws which hold the lenses to the hemisphere faces. We were able to find an improved method of connecting leads to the deflector elements, which along with cleaning off the Electrodag eliminated most of our problems with shorts between deflectors and the lens elements.

With these changes we were finally able to apply the desired voltages without arcing. We then heated up the cathode and found that our cathode holder was not able to withstand the high temperature ($> 1000^{\circ}\text{C}$). After trying several

alternative holders we found that we could use the original holder if we were careful to stay below 1000°C. With a few modifications this turned out to be sufficient to obtain the desired anode current of 1.5 ma, in fact up to 5 mA.

After this we were able fairly quickly to obtain a beam from the monochromator, using our current monitors to work the beam through the apertures and hemispheres into the accelerator tubes and onto a phosphor screen at the sample position. Our working voltages are quite close to the design voltages in most cases but we are in the process of improving the focus of the beam. The next step is to detect the beam using the analyzer, and finally to begin our experiment.

III. ELECTRONICS

At the end of the first year the major unfinished item of electronics equipment was the power supply for the lens voltages. Construction was begun by Gregory Shinkaveg, who left the project last September. After the wiring was completed we found that several modifications had to be made in order to obtain the required lens voltages. We had purchased safety terminals rated to 10kV which began breaking down at 5kV and had to be replaced. The switches for the current-monitoring system broke down at less than their rated voltage and had to be replaced. With these and similar modifications the supply now delivers the required voltages.

The digital electronics system for sending control signals to the terminal over the optical fibers has been completed by Brian McAllister as part of his B.S. Thesis project. We have been able to control the current to the deflection coils and to move the sample manipulator with the terminal at 230 kV.

Brian McAllister also wrote a number of computer programs to collect data from the Electron Multiplier via the computer's digital input module, and to connect the spectra for multiple scattering. We have two methods of collecting data from the electron multiplier. The first involves simple pulse counting using an Amptek pre-amplifier. For stronger signals where the pulses are too fast for the computer (more than 500/sec) we have purchased a frequency counter with digital output; Edward Horton has built an electronic circuit to collect data from the frequency counter and transmit it to the computer. This circuit is now being tested.

IV. HIGH VOLTAGE TERMINAL

After the high voltage terminal was completed, we attached dropping resistors between the electrodes of the accelerator and decelerator tubes and mounted magnetic shielding washers to every other electrode. We also completed the high-voltage cabling and found that one output of the isolation transformer was not connected. To repair this, we had to lift the transformer out of its tank and re-attach the output lead. We then tested the high-voltage system and found that we had arcing along the three input cables, one from the 300 kV power supply and two from the isolation transformer. We corrected this by surrounding the cables with a series of copper rings connected by dividing resistors, to drop the potential more uniformly along the cables. We used the same method, with plexiglas plates, to prevent arcing along the optical fibers.

With the above changes and with careful placement of the resistors we have been able to set the high voltage to up to 240 kV for extended periods of time.

V. SAMPLES

Our approach to preparing thin, 0.1 to 0.2 μm , samples of GaAs used three different methods, selective etching from (Al,Ga)As substrates, ion milling, and photoresistive masking followed by etching. These were carried out by two undergraduates, Amy Luttinger, as her B.S. Thesis project, and Chee Kong Mok. We used the sample polishing facilities of Prof. Harry Gatos of the Materials Sciences Department.

The method of ion milling was not very successful. We used an ion mill in the Earth and Planetary Sciences Department. Beginning with samples less than 15 μm thick, we attempted to mill holes leaving 0.1 to 0.2 μm intact. This turned out to be impossible because of the uncertainty of the initial thickness, the uncertainty in the milling rate, and the fact that milling could not be re-started on sample below 1 μm without breaking the sample. The best results were perforated holes with thin edges.

The most successful method was using selective etching. Ralph Logan of Bell Laboratories sent us four samples consisting of GaAs substrate, 0.5 μm $\text{Al}_{0.65}\text{Ga}_{0.35}\text{As}$ layer, and 0.1 or 0.2 μm GaAs layer on top. The top layers were protected with wax on a slide and the substrate was polished and then etched away using H_2O_2 or NaOH. Then the (Al,Ga)As was etched away using concentrated HF, leaving a free-standing GaAs sample. We now have one 0.1 μm and one 0.2 μm thick, and two more "sandwiches" to be processed.

We have been exploring the method of etching larger-area samples with small areas left unprotected by a photoresist mask. We have tried etching by immersion and anodic oxidation, and plan to investigate jet etching. So far none of our efforts have produced the thin, flat areas needed for our samples. These techniques may be needed for other materials where other methods do not produce thin enough samples. Some other techniques are cleaving, which we plan to use for the

the layered materials, and, for amorphous materials, sputtering onto a substrate such as Formvar or Victawet which can be dissolved away. We also have purchased a few electron microscope grids with Formvar or carbon films to use as permanent substrates if necessary.

We have two methods of holding samples. For larger-area samples, we have copper plates with holes of various sizes which screw onto a holder suspended from the sample manipulator. For low-temperature work, we have a holder with a hollow stainless-steel section for low thermal conduction. The holder is connected to the refrigerator using several pieces of copper braid. We will mount very small samples, such as those from the ion mill, on electron microscope grids. We have made a holder for these grids with slots into which the grids slide, with a cover plate which holds the grids in position.

VI. DATA REDUCTION AND THEORY

In addition to the computer programs which control the stepping motors and deflection coils, a number of programs have been written to collect and reduce our data. One program steps the energy-loss voltage, collects a fixed number counts from the electron multiplier, and records the time interval at each step. A second program collects data from the frequency-counter data-collection electronics. A third program corrects the data for multiple scattering by estimating the energy-loss intensity I_2 due to double-scattering events and subtracting this from the data using the convolution

$$I_2(\Delta E) = \frac{1}{2} \int_0^{\Delta E} I(\Delta E') P_1(\Delta E - \Delta E') d E' , \quad (1)$$

where the single scattering probability per energy interval is $P_1 \approx I(\Delta E)/I_0 \Delta E_r$, with I_0 the incident beam intensity and ΔE_r the energy resolution. Another set of programs is being written, to carry out a Kramers-Kronig analysis of the data to obtain the real and imaginary parts of the dielectric function.

The data we obtain on the complex dielectric function of GaAs will be interpreted in terms of a phenomenological band structure model due to Dresselhaus and Dresselhaus. This involves the development of an effective-mass Hamiltonian in terms of a Fourier expansion for the coupled valence and conduction bands. The coefficients in the expansion are determined by fitting the eigenvalues of the Hamiltonian to experimental data for the energy-bands at convenient points in the Brillouin zone (i.e. high symmetry points).

The original model Hamiltonian for the diamond structure uses an expansion to second-nearest neighbor distance and eight coupled valence and conduction bands. We have modified the diamond (O_h) symmetry of this Hamiltonian to the tetrahedral (T_d) symmetry of GaAs by the addition of a symmetry breaking zeroth-order perturbation to the Hamiltonian. This increases the number of band

parameters by two for a total of fifteen. We have written a computer program to fit these parameters to the best existing data for twenty energy gaps in the band structure. From this initial set of parameters we will be able to derive analytic expressions for the energy-bands along high symmetry directions in the Brillouin zone. The energy values at all other points in the zone can be determined numerically.

The dispersion relations, $E_n(\underline{k})$, so obtained will be useful for studying the frequency dependence of the dielectric constant since their determination is based on the behaviour of the energy-bands in the vicinity of a few high-symmetry points. The dielectric constant is sensitive to band ordering and will be useful in identifying structure in our data with critical points. The dielectric constant can be calculated using an approximate expression due to Ehrenreich and Cohen:

$$\epsilon(\omega) = 1 - m_0^{-1} \left(\frac{e}{\pi}\right)^2 \int d\underline{k} \sum_{n,n'} f_n(\underline{k}) f_{\mu n' n} \left[\omega - \omega_{nn'} + \frac{i}{\tau_{nn'}} \right]^{-1} \left[\omega + \omega_{nn'} + \frac{i}{\tau_{nn'}} \right]^{-1}$$

where n, n' are band indices, $f_{\mu n' n} = \left(\frac{2}{\hbar m_0 \omega_{n' n}} \right) / p_{\mu n' n}$ is the oscillator strength, $p_{\mu n' n}$ is the momentum matrix element in the μ direction, and $\tau_{nn'}$ is the relaxation time. A Monte Carlo procedure can be used to select \underline{k} points for the integration. Also, the location of critical points can be facilitated by determining the minimal set consistent with tetrahedral symmetry.

Finally, our data for the dielectric function of GaAs will be compared with the calculated function and with previous theoretical and experimental results. Needed changes in the model band structure will be identified by this comparison and the model will be adjusted until agreement is obtained. The result will be a new, more accurate experimental band-structure for device modelling and for comparison with future theoretical calculations.

VII. PERSONNEL

There have been a number of changes in the group in the past year. In September one graduate student, Gregory Shimkaveg, left the group and a new graduate student, Gary Gibson, joined us from Stanford University. Another graduate student, Edward Horton, joined the group in June.

Two undergraduates, Amy Luttinger and Brian McAllister, completed their undergraduate work, including B.S. Theses in our group, and have left M.I.T. Two other undergraduates, Chee Kong Mok and Mary Finn, worked with us starting this June, in the UROP program (Mok) or part of a Special Problems Course (Finn). Another graduate student, Jerome Licini, plans to join the group this fall.

VIII. PUBLICATIONS AND THESIS

a) Meeting speech

"High-Energy Electron Energy Loss Spectroscopy of GaAs,"

A. T. Futro and M. H. Weiler, APS Meeting, Phoenix, AZ,

March 1981.

b) Theses

"Preparation of Thin GaAs Samples," Amy L. Luttinger,

B.S. Thesis, M.I.T., June 1981.

"Computer Control and Data Collection in Electron Energy-Loss

Experiments," B.S. Thesis, M.I.T., June, 1981.

FIGURE CAPTIONS

Fig. 1. Schematic diagram of HELS experiment.

Fig. 2. Schematic diagram of double-selector monochromator assembly.

Fig. 3. Schematic electronics and electrical diagram.

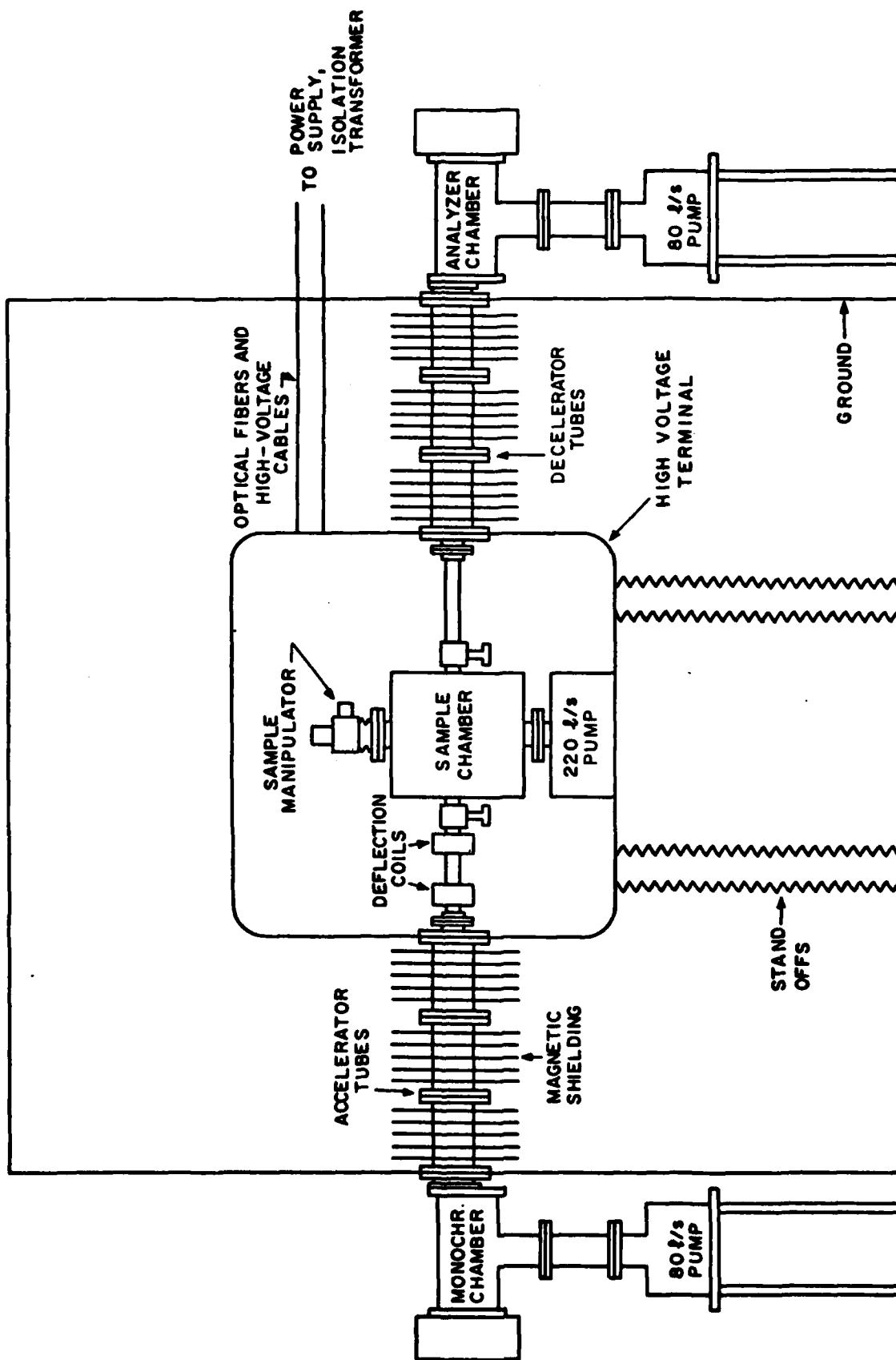

Fig. 1

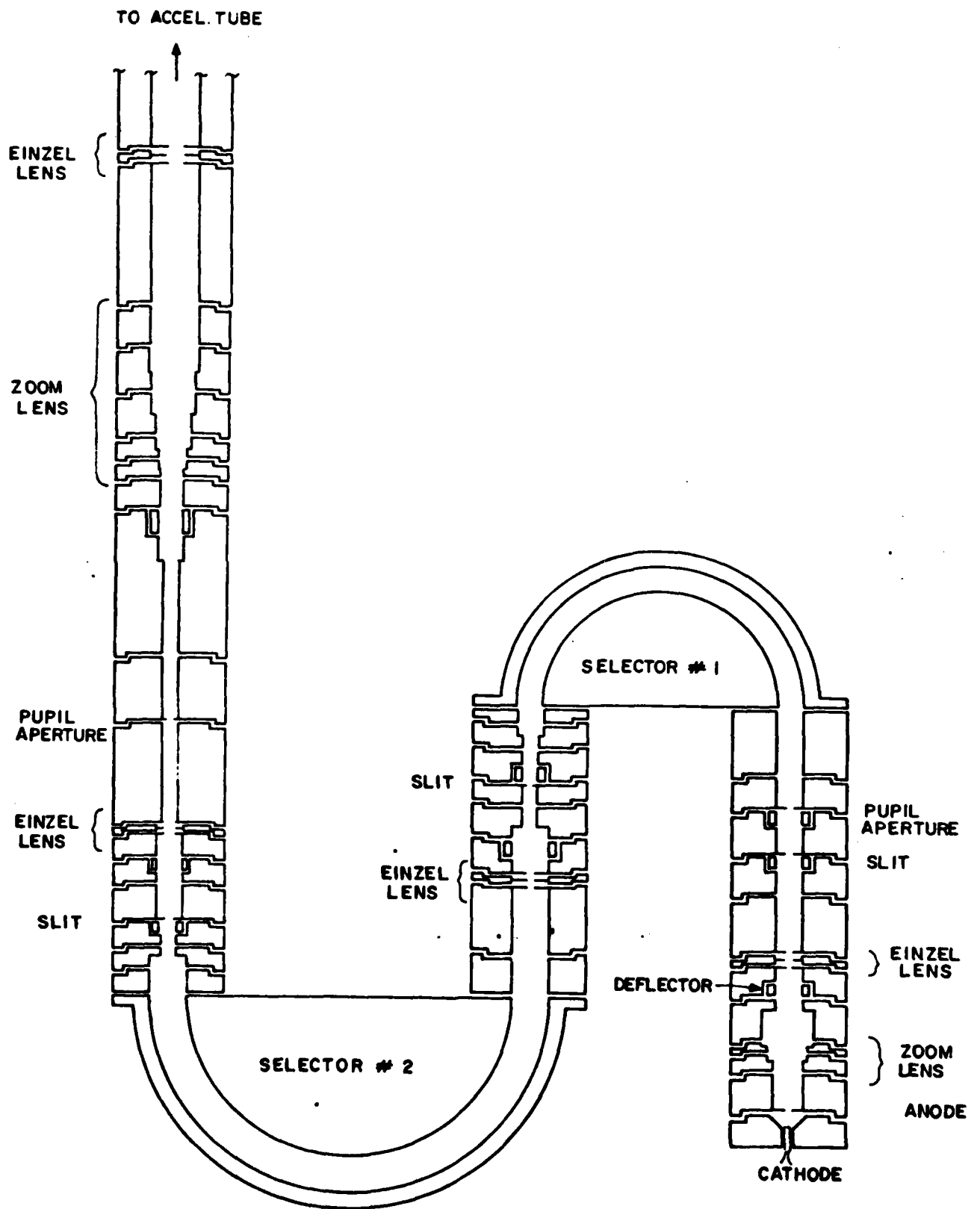

Fig. 2

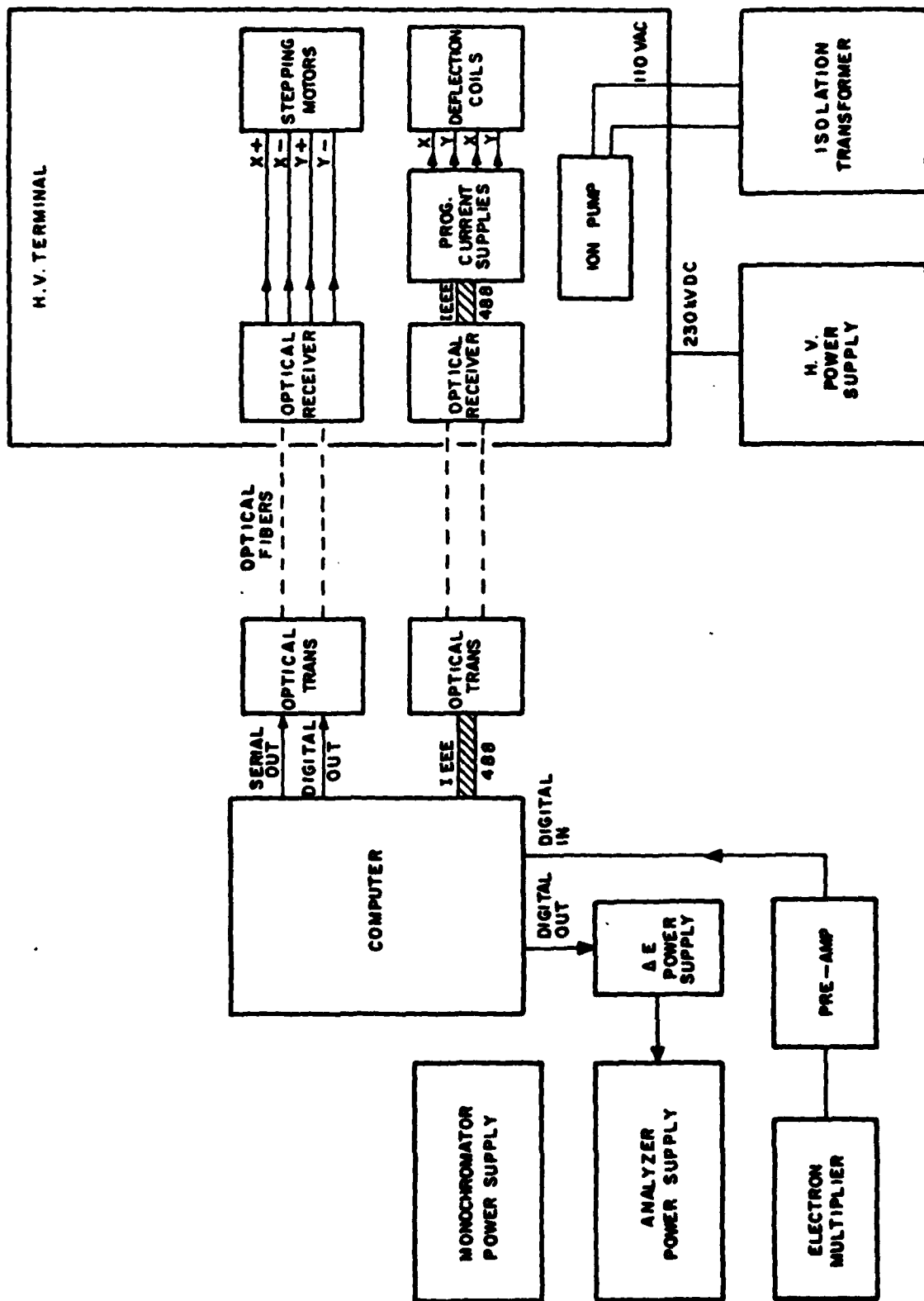

Fig. 3

END

DATE
FILMED

1-82

DTIC