

UNCLASSIFIED

DEPARTMENT OF DEFENCE

AR-002-617

DEFENCE SCIENCE AND TECHNOLOGY ORGANISATION

ELECTRONICS RESEARCH LABORATORY

TECHNICAL MEMORANDUM

ERL-0210-TM

PROPOSED DIGITAL CARTRIDGE RECORDING SYSTEM FOR WRELADS

T.R. Adams and D.M. Phillips

S U M M A R Y

The present data recording system in WRELADS II uses a hybrid tape recorder. Signal waveforms are recorded in analogue form while system parameters are recorded digitally.

The hybrid recording system has several disadvantages that would be overcome by introducing a fully digital recording system. A proposal is described for developing a system to utilize two high-capacity digital cartridge recorders in conjunction with a microprocessor based cartridge controller.



---

POSTAL ADDRESS: Chief Superintendent, Electronics Research Laboratory,  
Box 2151, GPO, Adelaide, South Australia, 5001.

---

UNCLASSIFIED

## TABLE OF CONTENTS

	Page
1. INTRODUCTION	1
2. PRESENT HYBRID TAPE RECORDING SYSTEM	1
2.1 Analogue waveform recording using a vidicon	1
2.2 Analogue waveform recording using digital waveform recorder	2
2.3 Digital recording of system parameters	2
2.4 Limitations of hybrid recording	2
3. PROPOSED DIGITAL CARTRIDGE RECORDING SYSTEM	3
3.1 Cartridge Controller	3
3.2 Parallel link with Waveform Recorder	3
3.3 Parallel link with data controller	3
3.4 Digital Cartridge Recorders	3
3.5 Sequencer link	4
4. SYSTEM DESIGN CONSIDERATIONS	4
4.1 Cartridge Processor Timing	4
4.2 Cartridge Processor Operation	5
4.3 Control of cartridge recorders	5
5. DEVELOPMENT WORK REQUIRED	6
5.1 Hardware	6
5.2 Software	6
5.3 Interfacing with WRELADS	6
5.4 Aircraft Operation	6
5.5 Documentation	7
5.6 Quantity	7
6. CONCLUSION	7
REFERENCES	8

## LIST OF TABLES

1. TENTATIVE DATA CONTROLLER DATA FORMAT (2 SECOND FRAME)	9
---	---

	Page
2. HCD75 CARTRIDGE TAPE UNIT SPECIFICATIONS	9
3. CARTRIDGE DATA FORMAT FOR EACH DIGITIZED WAVEFORM	10
4. CONTROL DATA TO DATA CONTROLLER	10
5. CONTROL DATA FROM DATA CONTROLLER	11

LIST OF FIGURES

1. Return signal bandwidth reduction using vidicon
2. Schematic diagram of proposed digital cartridge recording system

## 1. INTRODUCTION

(U) The Laser Airborne Depth Sounder (LADS) being developed at the Defence Research Centre Salisbury for the Royal Australian Navy Hydrographer will form part of an automated chart production facility being developed at the Hydrographic Office in North Sydney(ref.1). The system concept, operation and early trials results are described by Clegg and Penny(ref.2). The data obtained by LADS will be recorded on magnetic tape, subjected to processing, and ultimately stored in digital form on magnetic tape in the archives of the Hydrographic Office ready for use in the production of charts in the future(ref.3).

(U) The information stored in the hydrographic archives will consist of horizontal position information, depths and a classification parameter indicating the quality or confidence of the data. However, the LADS system will record the entire waveforms of the reflected laser signals so that these waveforms can be subjected to subsequent analysis in order to obtain the highest possible utilisation of the data. Because laser hydrography is still in an experimental phase there is further work needed on the analysis of these waveforms in order to optimise the amount of depth information obtained. The recording of the complete waveforms however imposes considerable demands on the data recording system.

(U) Originally, the waveforms were to be recorded using a vidicon and other specially developed electronics to reduce the bandwidth of the waveform signal from about 200 MHz to about 10 kHz so that it could be recorded in an analogue form using an audio tape recorder. Other system parameters were to be recorded in a digital form. To meet these two requirements a Honeywell hybrid taperecorder with some analogue and some digital tracks was used.

(U) Subsequently, a digital waveform recorder made by Biomation became available. This made it possible to produce digitized waveforms directly without the use of the vidicon analogue system. However, the Honeywell hybrid tape recorder could only record these waveforms in analogue form. As a result, an analogue facsimile of the digitized waveform is recorded. However, there would be considerable advantages in retaining the data in digital form when it is recorded.

(U) This memorandum describes the present and proposed systems. It also specifies the work needed to implement full digital recording in the system.

## 2. PRESENT HYBRID TAPE RECORDING SYSTEM

### 2.1 Analogue waveform recording using a vidicon

(U) The laser return signal detected by the photomultiplier in the LADS system can have a rise time of about 2 ns, which requires a bandwidth of about 200 MHz. The duration of the signal is about 500 ns and one pulse is received about every 12 ms in the WRELADS (84 Hz) system. Thus, by expanding the signal in time by a factor of about 20 000, the bandwidth of the signal could be reduced by the same factor, that is to about 10 kHz, which can then be recorded by an audio tape recorder.

(U) The system intended to achieve this waveform expansion is illustrated schematically in figure 1. The original 200 MHz signal was to be displayed on the screen of a fast oscilloscope. This waveform was to be imaged onto a vidicon which scanned the picture producing an output video signal of bandwidth 5 MHz. By orienting the vidicon so that each line scanned up the oscilloscope screen, it was intended to detect the point (and therefore the time) at which the video signal increased due to crossing the waveform. By

converting these times to amplitudes, the bandwidth could then be reduced to the desired 10 kHz for recording on an analogue channel of the Honeywell hybrid tape recorder. However, this complex system was abandoned when the Biomation Waveform Recorder became available.

## 2.2 Analogue waveform recording using digital waveform recorder

(U) The Biomation waveform recorder allows the bandwidth reduction to be achieved in one step. The fast waveform is sampled at 2 ns intervals and the values are stored in digital form in memory. These values can subsequently be read from the memory at whatever rate is required. By using a sampling rate of 25 kHz and using a digital to analogue converter, the analogue signal required for recording on the Honeywell hybrid tape recorder can be obtained.

(U) The Biomation waveform recorder represents a significant advance on the vidicon system because it eliminates the distortion associated with the optics and the electron optics of the vidicon.

## 2.3 Digital recording of system parameters

(U) In addition to the waveforms, system parameters are also monitored to facilitate subsequent analysis of the data. The format for these parameters in the proposed digital recording system is given in Table 1.

(U) Some of these parameters, such as time, are already digital but others are analogue and must first be converted to digital form with an analogue to digital converter. The data rate associated with the full set of digital data is very much lower than that associated with the waveforms. Consequently all the system parameters can be recorded in digital form on one track of the Honeywell tape recorder.

## 2.4 Limitations of hybrid recording

(U) Although some of the problems associated with recording the waveforms are overcome when the Biomation waveform recorder is used other problems still remain. Inaccuracies are introduced in the conversion of the digital data from the Biomation waveform recorder to an analogue signal and further inaccuracies are associated with the inverse conversion from analogue back to digital in the ground processing system.

(U) The tape recorder has a limited frequency response and this tends to degrade the fast rise times of the surface and bottom signals which are so important for retaining the accuracy of depth measurements. It is also possible that small variations in tape speed could change the data between recording and playback.

(U) There is also a problem of the time lag between the analogue wave-forms and digital data. The analogue waveforms are recorded in real-time whereas the digital data is stored in a buffer memory to form a two second block of data, which is subsequently written out. As a result, it is necessary to reestablish in the ground processing system the relationship in time between the digital data and the analogue wave-forms.

(U) Finally, the hybrid magnetic tapes are unsuitable for direct use with a computer and are thus not the most suitable form for storing the raw trials data. The data must be digitized and then recorded on a magnetic tape in a computer readable format. On the other hand, if the data were acquired digitally in the first place, there would be no need to produce another copy of the trials data in a different format.

### 3. PROPOSED DIGITAL CARTRIDGE RECORDING SYSTEM

(U) The proposed digital cartridge recording system is required to acquire waveform data from the Biomation Waveform Recorder and other data from the WRELADS system, to format this data with appropriate synchronization and to pass the data to the digital cartridge recorders.

(U) A schematic diagram of the proposed system is given in figure 2. The Cartridge Controller would be a new microprocessor based system, which would receive the necessary data from the existing Biomation Waveform Recorder and Data Controller. The data would be passed alternately, one word at a time, to the two digital cartridge recorders.

#### 3.1 Cartridge Controller

(U) A Cartridge Controller that is separate from the Data Controller is proposed, because it lends itself to the development of a self-contained package while minimizing disruption to the existing hybrid recording system. All functions presently performed by the Data Controller would remain after introduction of the fully digital system, with the exception of the serial tape link which would become redundant.

(U) An alternative would be to modify the existing Data Controller to a multiprocessor system, utilizing Intel 8089 I/O processors dedicated to the task of communicating with the cartridge recorders. However, to accommodate the greatly increased data transfer rate, considerable effort would be required in the design of hardware, development of software, and system testing. Both the amount of work involved and the extent of disruption to the existing system would be much greater than for the proposed system.

#### 3.2 Parallel link with Waveform Recorder

(U) A unidirectional parallel (6 bit) communication link is required to acquire the digital facsimile of the return laser waveform from the Biomation Waveform Recorder. Each digitized waveform constitutes 267 discrete 6 bit samples, comprising 25 pedestal and 242 waveform samples. At a laser repetition rate of 168 Hz, 44 856 transfers occur each second across this link.

#### 3.3 Parallel link with data controller

(U) Bidirectional parallel communication is required between the Cartridge Controller and the Data Controller. Digital data are to be passed from the Data Controller at the rate of 1 512 bytes of 8 bit data each second. This data encompasses system housekeeping parameters, control settings, navigation information and various experimental parameters which vary according to need. A small number of bytes (<20) will be required from the Cartridge Controller, which will reflect test results and error conditions that may arise in the digital recording system. These parameters will enable the Data Controller to take appropriate action and bring to the notice of the operator any fault conditions which may arise.

#### 3.4 Digital Cartridge Recorders

(U) The proposed system will contain two digital cartridge recorders (Model No.HCD75) manufactured by the 3M Company (see Table 2 for specifications). Each recorder has a maximum average data transfer rate of 17.5 k bytes/s and a capacity of 67 M bytes. Thus the recording time at the maximum data rate is about 64 min. By operating two recorders in parallel, data can be recorded at a maximum rate of 35 k bytes/s.

(U) As mentioned in Section 3.2, the Biomation Waveform Recorder supplies data, consisting of 6 bit samples, at a rate of 44 856 transfers/s. To remain within the maximum data rate of the cartridge recorder, the first 15 samples for each digitized waveform are to be discarded, the remaining 252 being compacted to 8 bit bytes which corresponds to a data rate of 31 752 bytes/s. Two data bytes which define waveform position relative to the 0.5 Hz synchronizing signal are to be appended to each waveform data block (Table 3). As mentioned in Section 3.3, the Data Controller will supply 8 bit data at a rate of 1 512 bytes/s. Therefore, the total data rate to the cartridge recorders will be 33 600 bytes/s which is just below the maximum attainable rate.

### 3.5 Sequencer link

(U) All acquisition of system data is synchronized to the 168 Hz and 0.5 Hz signals generated by the Sequencer. To ensure the consistent and accurate recording of this data the Cartridge Controller must also be synchronized to the same signals.

## 4. SYSTEM DESIGN CONSIDERATIONS

### 4.1 Cartridge Processor Timing

(U) Because of the relatively high data transfer rate through the Cartridge Controller, direct memory access (DMA) parallel links are needed. The following is an approximate breakdown of the main processor times, based on an 8085 CPU with DMA links and a 2 MHz clock.

Data Transfers from Biomation Waveform Recorder:	44 856 samples/s
Data Transfers to Cartridge Recorders:	33 600 bytes/s
Data Transfers from Data Controller:	1 512 bytes/s
TOTAL:	79 968 transfers/s

(U) Assuming a transfer time across a DMA parallel link of 2  $\mu$ s, data transfers will account for about 160 ms of each second.

(U) The other major demand on the Cartridge Processor (apart from data transfers) will be the compacting of 6 bit waveform samples into 8 bit bytes. This will be achieved by packing groups of four 6 bit numbers into three bytes. The available time, after allowance for data transfers, is 840 ms in each second. It follows that each group of 3 bytes must be packed in less than 79  $\mu$ s. This should be achievable in a system based on a 2 MHz clock.

## 4.2 Cartridge Processor Operation

(U) Ultimate control of the cartridge recorders must remain with the Data Controller. Inherent in the format of data passed from the Data Controller will be a number of control bytes which instruct the Cartridge Controller to perform specific tasks. These tasks include a number of tests as detailed below. The results of these tests will be passed to the Data Controller as will any error conditions which should arise during normal tape operations.

### CPU test

(U) A complex arithmetic function designed to exercise a wide cross-section of CPU instructions will be executed, the result being compared with the expected value stored in ROM.

### ROM test

(U) A checksum test will be performed on all ROM's in the system. The checksum derived will be compared with a checksum previously generated and also held in ROM.

### RAM test

(U) Various data patterns will be stored in RAM and then reread and compared with the original pattern.

### Cartridge recording test

(U) A block of known data, eg repetitive 0 to FF (hexadecimal) will be written to the tape units, read back and compared with the data transmitted.

### System test

(U) The Cartridge Controller will be required to accept a block of data from the Data Controller, read five digitized waveforms from the Biomation, and write this combined data to the cartridge recorders. The data is subsequently to be read from tape and transferred to the Data Controller for evaluation.

(U) The first three tests are to be performed upon power up, the results being placed in the appropriate data byte for transfer to the Data Controller. A front panel fail LED is to be illuminated upon Cartridge Controller power up and extinguished 10 s later if the tests prove satisfactory. All five tests may be initiated under software control at the discretion of the Data Controller.

## 4.3 Control of cartridge recorders

(U) Immediately after the power up sequence, the Cartridge Controller will be required to interrogate both cartridge recorders to determine status. If either unit is deemed inoperative (eg no cartridge) the appropriate information must be conveyed to the Data Controller (Table 4). Upon receipt of a 'write' command, the Cartridge Controller must initiate data recording at the next 0.5 Hz pulse.

(U) Since the data rates dictate the use of two cartridge recorders, care must be taken to ensure synchronization between units. The cartridges in both units must therefore be suitably positioned by the Cartridge Controller prior to the commencement of the write operation. At this stage

recording should begin at track 1 in the first user block of the tape cartridge in drive 1, 16 bit words then being passed alternately to drives 1 and 2.

(U) If any operational change is required during normal write operation, the Data Controller will attract Cartridge Controller CPU attention via an interrupt control line which will direct the Cartridge Controller software to the appropriate tape control byte (Table 5). The Cartridge Controller will then take appropriate action.

(U) Transmission of data to the Data Controller need only be initiated to pass the results of a test or to inform of a cartridge recorder status change. Any such transmission will be interpreted as an interrupt requesting Data Controller attention.

(U) The Cartridge Controller must also respond should the 'ATTENTION' line from either drive go 'high'. This indicates detection of an abnormal internal condition or End of File requiring appropriate action. Details of drive status should be passed to the Data Controller.

(U) If a break in recording should occur, the Cartridge Controller must pass the number of unrecorded blocks remaining on the cartridges to the Data Controller. When a break in recording occurs, whether initiated by the Data Controller or in response to a cartridge recorder status change, the Cartridge Controller must take action in preparation for subsequent recording. Both tape cartridges must be advanced to the next free block; unused space in the partially recorded block being filled with null characters. Recording may then continue upon receipt of a write command at the next 0.5 Hz. pulse.

(U) Approximately 1 min prior to the end of tape, the Cartridge Controller must send a 1 min recording time warning to the Data Controller.

## 5. DEVELOPMENT WORK REQUIRED

(U) In order to implement the above proposal, work will be required to develop hardware and software, to interface the system with existing WRELADS equipment, to verify that it operates reliably in the aircraft environment and to provide full documentation.

### 5.1 Hardware

(U) It is envisaged that the requirements described above can be met by an 8 bit microprocessor system.

### 5.2 Software

(U) Programs will need to be developed to control the transfer and compaction of data. A high level language such as PLM should be used to facilitate subsequent program changes, should they be needed.

### 5.3 Interfacing with WRELADS

(U) Laboratory tests will be needed to ensure that the Cartridge Controller interfaces correctly with existing WRELADS equipment and the 3M cartridge recorder.

### 5.4 Aircraft Operation

(U) The aircraft is an electrically noisy and vibration prone environment. Work will be needed to ensure that the system performs reliably when

operated in the Dakota aircraft.

#### 5.5 Documentation

(U) Full documentation is required, including mechanical drawings, electronic circuits, operating instructions, and full software listings.

#### 5.6 Quantity

(U) Two complete sets of hardware, software and documentation are required one for operation in the aircraft and the other for laboratory use. In addition a complete set of spare card modules is required.

### 6. CONCLUSION

(U) The digital cartridge recording system described in this memorandum will overcome the deficiencies of the present hybrid tape recording system. It will allow full digital recording of all waveforms for subsequent ground processing.

## REFERENCES

- | No. | Author                      | Title  |
|-----|-----------------------------|--|
| 1   | Calder, M.                  | "WRELADS - the Australian Laser Depth Sounding System".<br>Internat. Hydrographic Review, Vol. 52, pp31-54, 1980   |
| 2   | Clegg, J.E. and Penny, M.F. | "Depth Sounding from the Air by Laser Beam".<br>Journal of Navigation, Vol.31, pp 52-61, 1978  |
| 3   | Burrows, K.                 | "The Laser Airborne Depth Sounder and Charting in Australia".<br>Proceedings of the Fourth Laser Hydrography Symposium, 30 September to 3 October 1980.<br>ERL-0193-SD, 1981 |

TABLE 1. TENTATIVE DATA CONTROLLER DATA FORMAT (2 SECOND FRAME)

Byte Range	Type of Data
0 - 3	Control data for Cartridge Controller (refer Table 5)
4 - 45	System parameters - incorporates system control settings and flight information
46 - 1054	Aircraft height and water depth as determined by the airborne system
1055 - 1183	Navigation Data
1184 - 1337	Photomultiplier Gain Controller data
1338 - 3023	Not allocated - Experimental data

TABLE 2. HCD75 CARTRIDGE TAPE UNIT SPECIFICATIONS

- . Based on DC-600HC Cartridge (1/4" tape)
- . Preformatted tape 4096(1024 Byte Blocks) per track
- . 16 Track
- . 67 Megabytes formatted capacity
- . Data I/O - Parrallel by word; 16 bits/word
  - Dual 1024 byte I/O buffers
- . Transfer Rate - 4 M bytes/s maximum
  - 17.5 K bytes/s average
- . Recording density 197 bits/mm (5000 bits/inch)
- . Tape Speed - 76 cms/s (30 inches/s) Read/Write
  - 152 cms/s (60 inches/s) Search
- . Built in error detection - correction capabilities
- . MFM recording

TABLE 3. CARTRIDGE DATA FORMAT FOR EACH DIGITIZED WAVEFORM

No. of Bytes	Description
2	Waveform relative to 0.5 Hz synchronizing signal. (0 to 335 (binary) each 2 s frame)
9	Data from Data Controller
189	Compacted waveform data (pedestal and waveform)

TABLE 4. CONTROL DATA TO DATA CONTROLLER

Byte No.	Byte Function	Bit No.	Bit Function Bit = '0' : test failed
0	No. of bytes to be passed in 2 s frame	-	
1		-	
2	Test results	0	CPU test result
		1	ROM test result
		2	RAM test result
		3	Tape test result
		4-6	Not used
		7	1 minute recording time (Bit = '0' : 1 min remaining)
3	No. of recording blocks remaining		
4			
5 - 10	Status of drive 1 (format as per HCD75 Specification)		
11 - 16	Status of drive 2		

TABLE 5. CONTROL DATA FROM DATA CONTROLLER

Byte No.	Byte Function	Bit No.	Bit Function Perform if Bit = '1'
0	No. of bytes to be	-	
1	passed in 2 s frame	-	
2	Test Control	0	CPU test
		1	ROM test
		2	RAM test
		3	Tape test
		4	System test
		5,6,7	Not used
		3	Tape Control
1	Read		
2	Unload		
3	Initiallize		
4	Continue		
5	End of file		
6,7	Not used		

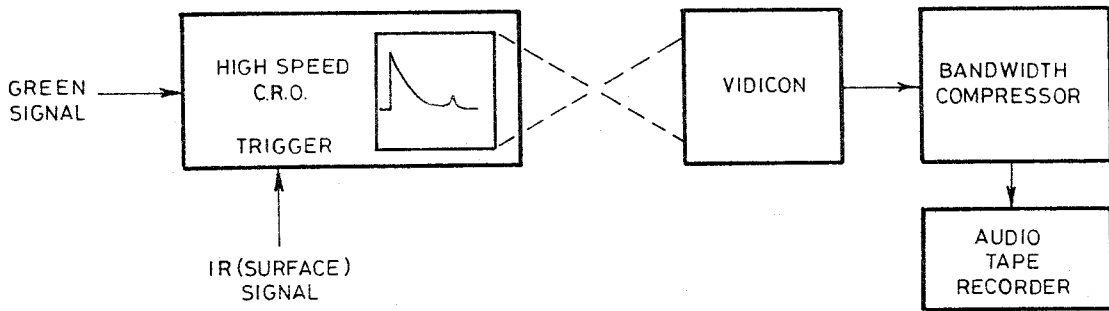

Figure 1. Return signal bandwidth reduction using vidicon

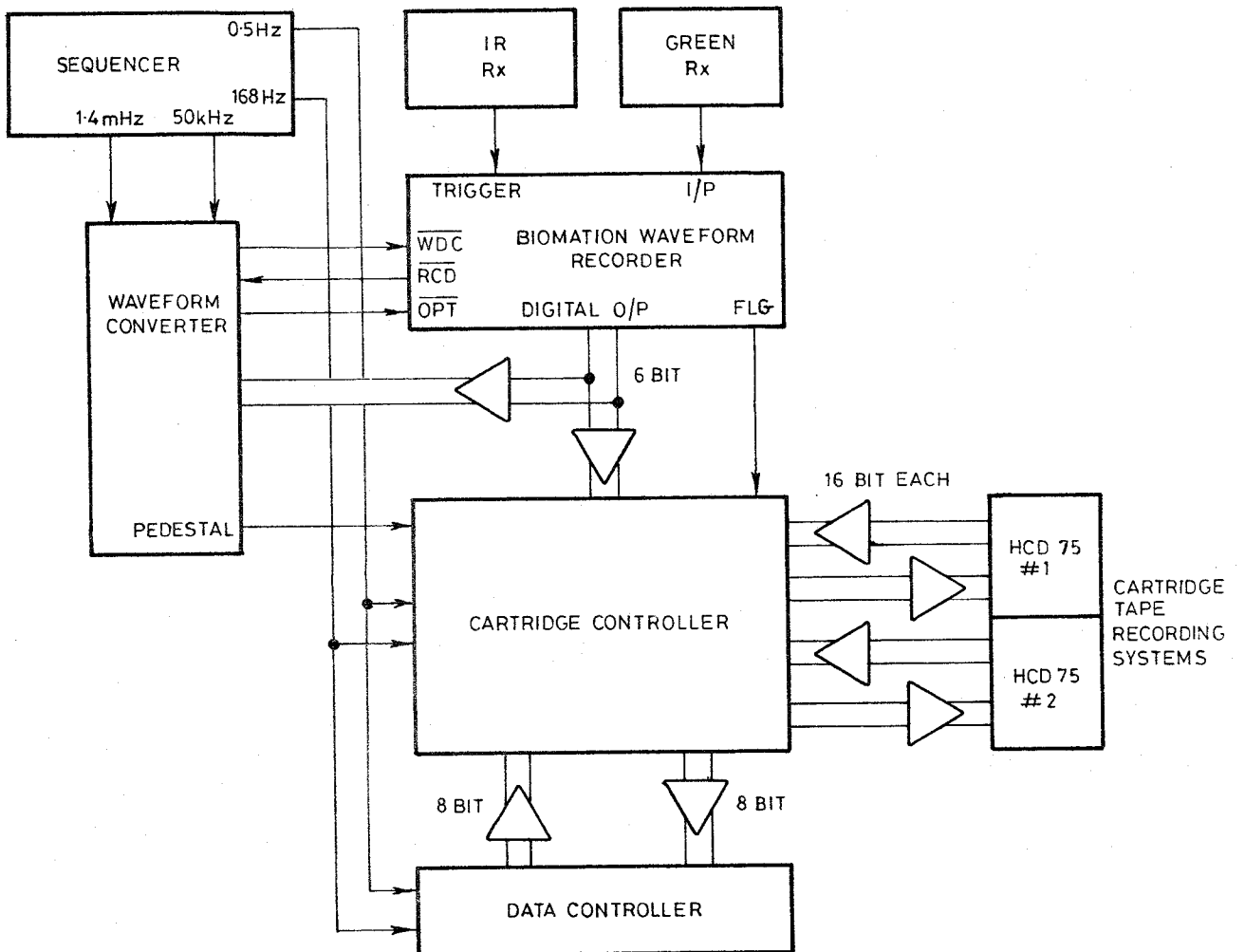

Figure 2. Schematic diagram of proposed digital cartridge recording system

DOCUMENT CONTROL DATA SHEET

Security classification of this page

UNCLASSIFIED

1	DOCUMENT NUMBERS
AR Number:	AR-002-617
Series Number:	ERL-0210-TM
Other Numbers:	

2	SECURITY CLASSIFICATION
a. Complete Document:	Unclassified
b. Title in Isolation:	Unclassified
c. Summary in Isolation:	Unclassified

3	TITLE
PROPOSED DIGITAL CARTRIDGE RECORDING SYSTEM FOR WRELADS	

4	PERSONAL AUTHOR(S):
T.R. Adams and D.M. Phillips	

5	DOCUMENT DATE:
August 1981	

6	6.1 TOTAL NUMBER OF PAGES	12
	6.2 NUMBER OF REFERENCES:	3

7	7.1 CORPORATE AUTHOR(S):
Electronics Research Laboratory	
	7.2 DOCUMENT SERIES AND NUMBER
Electronics Research Laboratory 0210-TM	

8	REFERENCE NUMBERS
a. Task:	NAVY 77/020
b. Sponsoring Agency:	DSTO/NAVY

9	COST CODE:
313412	

10	IMPRINT (Publishing organisation)
Defence Research Centre Salisbury	

11	COMPUTER PROGRAM(S) (Title(s) and language(s))

12	RELEASE LIMITATIONS (of the document):
Approved for Public Release	

Security classification of this page:

UNCLASSIFIED

13 ANNOUNCEMENT LIMITATIONS (of the information on these pages):

No limitation

14 DESCRIPTORS:

a. EJC Thesaurus Terms	Digital recording Microprocessors Hydrographic charts Charting	Data recording Depth finders
---------------------------	---	---------------------------------

b. Non-Thesaurus Terms	WRELADS
---------------------------	---------

15 COSATI CODES:

0810

16 SUMMARY OR ABSTRACT:

(if this is security classified, the announcement of this report will be similarly classified)

The present data recording system in WRELADS II uses a hybrid tape recorder. Signal waveforms are recorded in analogue form while system parameters are recorded digitally.

The hybrid recording system has several disadvantages that would be overcome by introducing a fully digital recording system. A proposal is described for developing a system to utilise two high-capacity digital cartridge recorders in conjunction with a microprocessor based cartridge controller.