

AD-W110 462

HARSHAW CHEMICAL CO SOLON OHIO  
STUDIES OF AN OPTICAL FIBER LIF DOSIMETER. (U)  
OCT 80

F/G 20/6

UNCLASSIFIED

DAAK20-79-C-0012  
NL

1 of 1

DATA

1-4-80



END  
DATE  
FILMED  
03-82  
DTIC

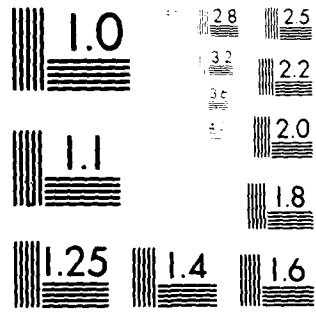

MICROCOPY RESOLUTION TEST - PART  
NATIONAL BUREAU OF STANDARDS

**LEVEL II**

①

AD A110462

HARSHAW CHEMICAL CO.  
SOLOON, OHIO

STUDIES OF AN OPTICAL FIBER  
LiF DOSIMETER

FINAL REPORT

Oct 80

DTIC  
SELECTED  
JAN 6 1982  
H

Work Performed for:

Fort Monmouth Procurement Office  
United States Army

Contract DAAK20-79-C-0012

*Arthur C. Lucas*

Arthur C. Lucas  
Program Director

**DISTRIBUTION STATEMENT A**  
Approved for public release;  
Distribution Unlimited

82 01 04 008

47 (6)

DTIC FILE COPY

STUDIES OF AN OPTICAL FIBER  
LiF DOSIMETER  
FINAL REPORT

---

1. Introduction

This report summarizes work performed for the Fort Monmouth Procurement Office of the United States Army under Contract DAAK20-79-C-0012. The work was directed at studies of the absorption processes for light in LiF and their applicability to construction of miniature, light-weight dosimetric system. The material chosen, LiF, exhibits narrow band optical absorption subsequent to irradiation with gamma rays. Several absorption bands are present in the range 240 to 550 nm. Of these the most significant are those occurring at 240 and 440 nm. The absorption bands are extremely stable with time and temperature and could form the basis for a reliable, stable gamma ray dosimeter system if sensitivity could be achieved through appropriate combinations of electronic and physical design.

2. Theory of Operation

Figure 2.0 shows an absorption spectrum for pure LiF which has been irradiated to a sufficient level to make all the absorption bands obvious when examined using a spectrophotometer. The bands, identified from order of greatest height to smallest are F, M, R, and N bands as classically named in the spectroscopic literature. They occur at 240, 440, 370, and 550 nm respectively. In order to form a measuring system, it is necessary to fabricate devices having a sufficient length to yield statistically valid measurements at the minimum detectable gamma ray exposure. In the case of carefully designed measuring systems which determine transmitted light compared to a reference sample, this criterion reduces to about 0.1 percent changes in transmitted light.

Absorption coefficients induced by irradiation for the two dominant absorption bands are:

$$\begin{aligned} &5.1 \times 10^{-5} \text{ per rad for the F band} \\ &1.1 \times 10^{-6} \text{ per rad for the M band} \end{aligned}$$

Engineering an electronic system to measure absorption at 440 nm is clearly less challenging than the comparable task defined for 240 nm and, as a result, emphasis has been placed on forming compact samples in the range 20 to 100 cm long.

3.0 Material Development

3.1 Initial Extrusions

A 1-inch diameter cavity was machined from Inconel 750 and fitted with a .015-inch diameter aperture plate. Extrusions were made at a temperature of 750°C at a rate of approximately 1mm per second. The



## 5.0 Experimental Evaluation

Samples were evaluated using the main frame of a Beckman DU Spectrophotometer as a monochromator. A high pressure deuterium lamp was used to provide ultraviolet radiations and a high intensity mercury lamp was used for the visible light evaluations of the long fibers. Long fibers were coupled to a 1/2-inch diameter photomultiplier and oriented into the light beam using lab jacks. Irradiations were made using unfiltered 200 KvP x-rays.

### 5.1 Evaluation of the Coiled Fiber

The coiled fiber was evaluated at 365, 436, and 540 nm in order to observe the absorption maximum for the M centers at 440 nm. Because of the irreproducibility of the positioning, absolute values of the measured signals scattered badly. Evaluation of the data were performed by taking the ratio of the 436 nm datum to the 365 and 540 nm data alternately. Table 5.1 shows the result of that tabulation for exposures up to 168,000 R. No detectable absorption was observed.

### 5.2 Evaluation of the Long Fiber

In a similar way, the 7-inch long fiber was evaluated for the M absorption. While the absolute value of the transmitted light was approximately 10 times that for the coiled sample, no absorption maximum was observed. Data were somewhat more random for the long fiber. No transmission was observed for either fiber at the wavelength of the F absorption, 240 nm, presumably because of the fact that the photomultiplier, necessary to detect the weak light, had a glass envelope.

### 5.3 Evaluation of the Single Crystal Sample

The single crystal sample was irradiated using 200 KvP x-rays as above and evaluated using 240 nm light detected by a vacuum photodiode having a quartz window. Figure 5.31 shows the value of the observations plotted as a function of exposure. The same data, converted to optical density, are shown plotted in Figure 5.32. The data demonstrate the principle of a system based on F band absorption.

## 6.0 Elements of a Working System

### 6.1 Lamp

A miniature, quartz, flash lamp, similar to that used in a portable camera flash unit, can be used to provide strong ultra-violet illumination. Operation at the minimum energy which supports a pulse provides sufficient light for accurate measurement. For example, a simple unit, passed through the Beckman DU spectrophotometer produced a 10 milliampere pulse at the detecting vacuum photodiode. The total charge collected in the pulse was  $2 \times 10^{-8}$  coulombs.

## 6.2 Band Pass Filter

High rejection ratios are conveniently available for passing 240 nm light. Values of the FWHM ranging from 5 to 40 nm are available. 20 nm FWHM is a reasonable value which provides near maximum density change for a given exposure while utilizing the light produced efficiently.

## 6.3 LiF Sample

Pure LiF is relatively economical to produce and may be reproducibly grown in unlimited quantities for this purpose. While tests have been made using a 1 cm path length, several centimeters could be used in a simple instrument and multipass geometries can be envisioned.

## 6.4 Light Detector

A special photovoltaic silicon photodiode has been provided Harshaw by Hamamatsu, a Japanese supplier of photomultipliers and silicon devices. The diode provides a signal to an electrometer 10 times as large as that obtained using the conventional vacuum photodiode. The diode requires no bias voltage and has offset currents of the order of  $10^{-11}$  amperes. It has been operated in the temperature range of 0 to 40°C. Figure 6.4 shows the wavelength dependence of the response of the diode.

## 7.0 Possible Block Diagram of a Working System

A working system would best be based on a large scale integrated circuits containing logic designed specifically for the task so as to conserve power and optimize precision. A very important feature of such a system is a method for normalization for changes in lamp power. A convenient method is to move the sample, operate the flash lamp, return the sample to its home and operate the lamp again. The ratio of the two signals can be an accurate measure of the absorbance in the sample if care is taken to design the lamp trigger for maximum stability. In practice, the sample motion could be linked mechanically to the pushbutton which initiates the readout cycle.

A system incorporating these principles is shown in Figure 7.1. Motion of the READ pushbutton is sensed by optical sensors so as to initiate a first lamp pulse as the switch is depressed. During this pulse the sample is out of the beam and the photodiode is irradiated directly by the ultraviolet light. As the READ pushbutton is released, a second light pulse is initiated by the controller. This second pulse of light passes through the LiF detector. In each case the total charge in the photodiode signal is integrated in a single operational amplifier circuit operated with negative feedback so as to achieve linearity. The value of the output of the amplifier is digitized and processed in the arithmetic unit. The amplifier is conveniently reset by a leakage resistor which provides a time constant of the order of 1000 microseconds.

8. Summary

A workable system for using the absorption bands of LiF in a dosimetry system has been shown to be feasible. Small extended fibers which readily pass ultraviolet light have not yet been produced. While some additional effort in that direction would seem to be justified, an F band system based on optically clear single crystal material would seem to provide the best chance of succeeding at this moment.

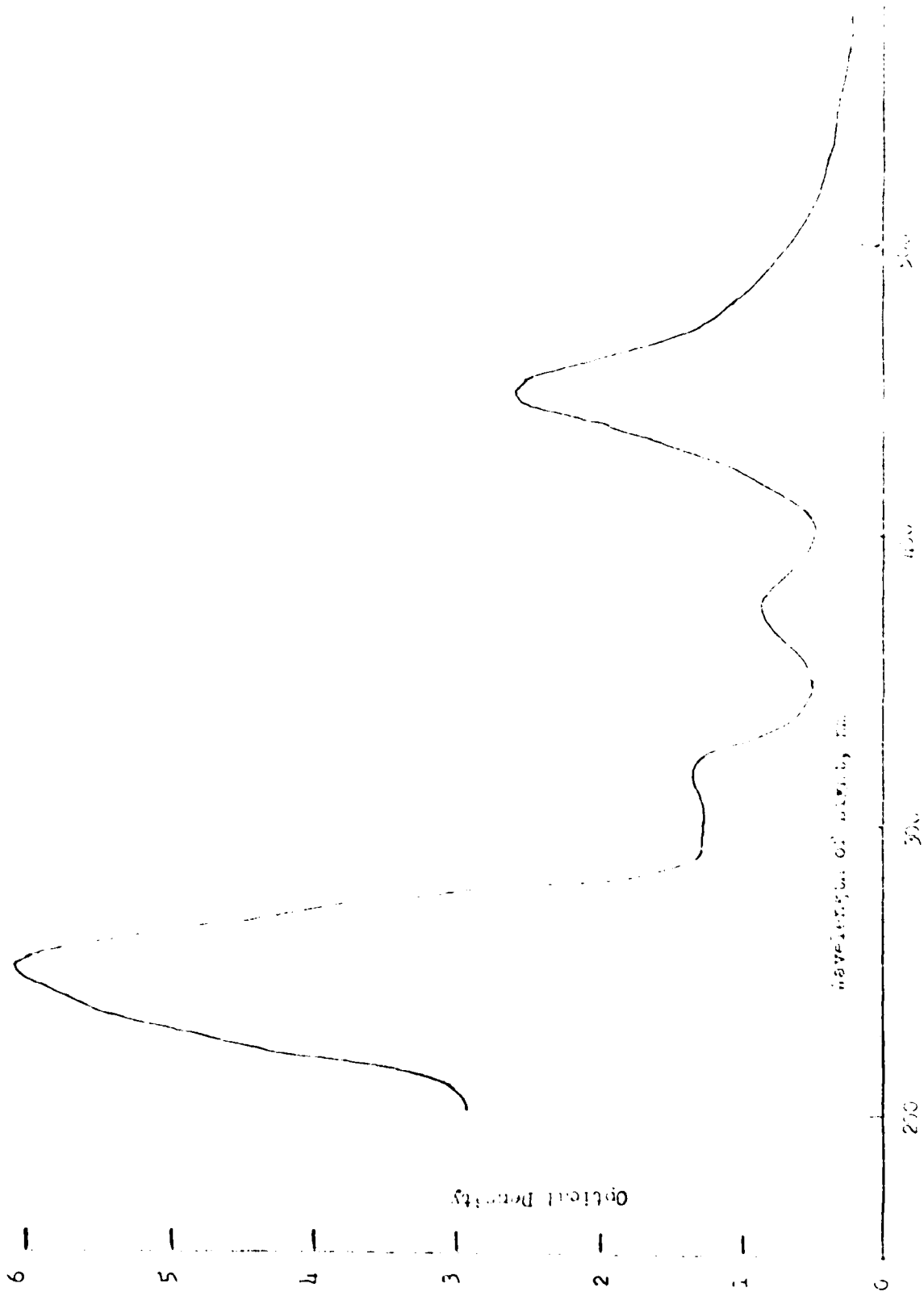

Figure 2.6. Absorption spectrum of a solution of a substance.

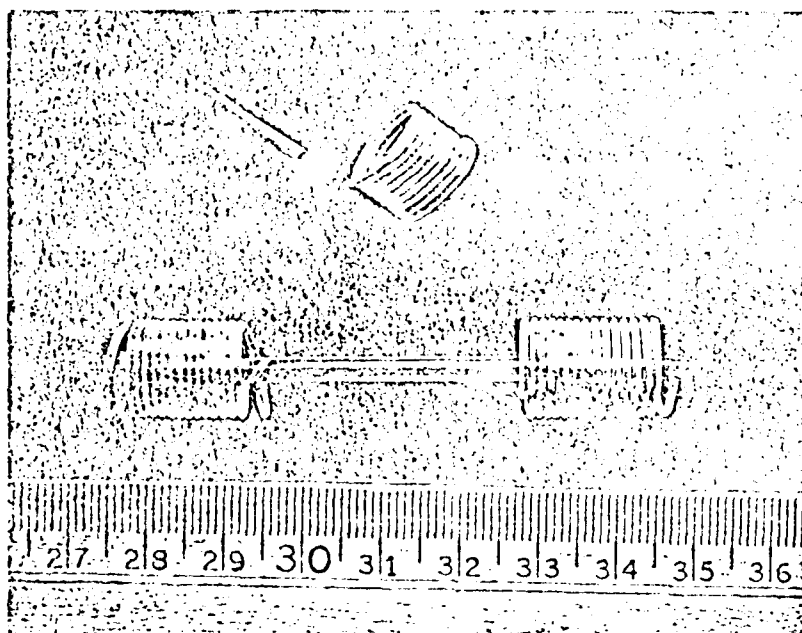

Figure 3.4. Photograph of examples of coiled LIF fibers.

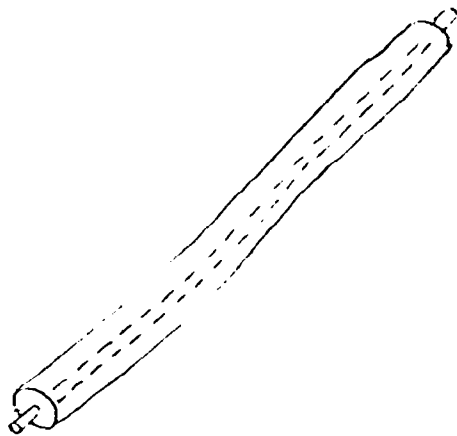

Figure 3.51. Sketch of an encapsulated long fiber.

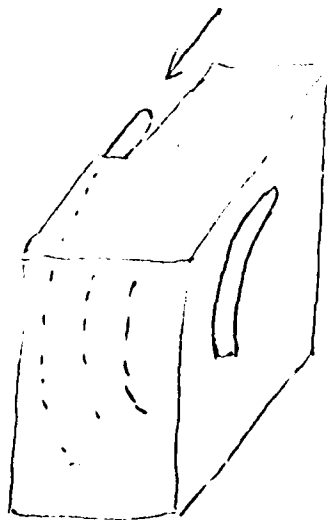

Figure 3.52. Sketch of an encapsulated coiled fiber.

<u>Exposure, R</u>	<u>T<sub>436</sub>/T<sub>540</sub></u>	<u>T<sub>436</sub>/T<sub>365</sub></u>
0	0.61	1.03
6165	0.66	0.89
64400	0.63	0.88
168000	0.61	0.87

Table 5.1. Evaluation of M band absorption in an encapsulated, coiled fiber. Significant darkening was not observed.

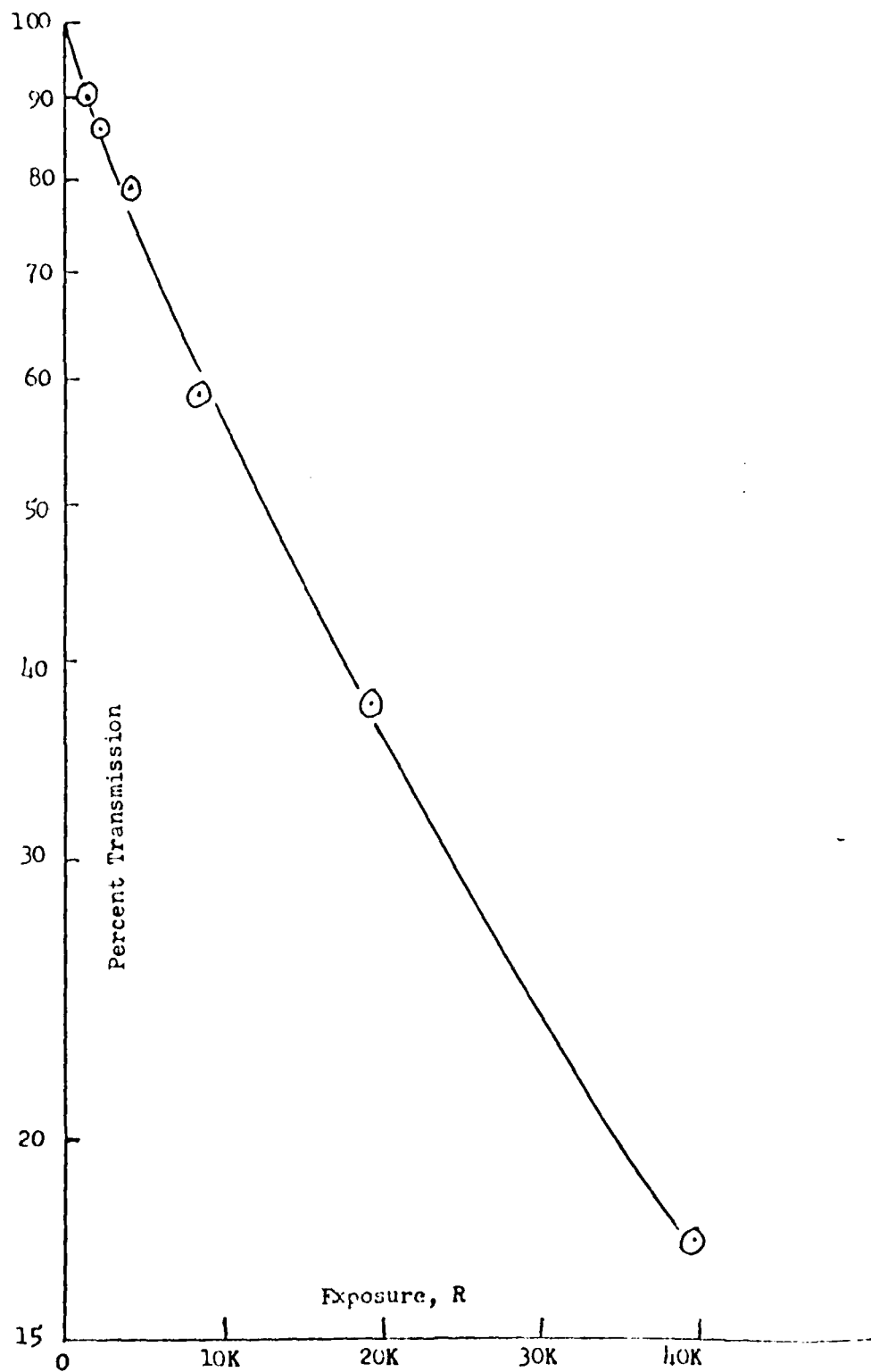

Figure 5.31. F band transmission through a 1 cm sample of single crystal LiF after exposure to 200 KvP x-rays.

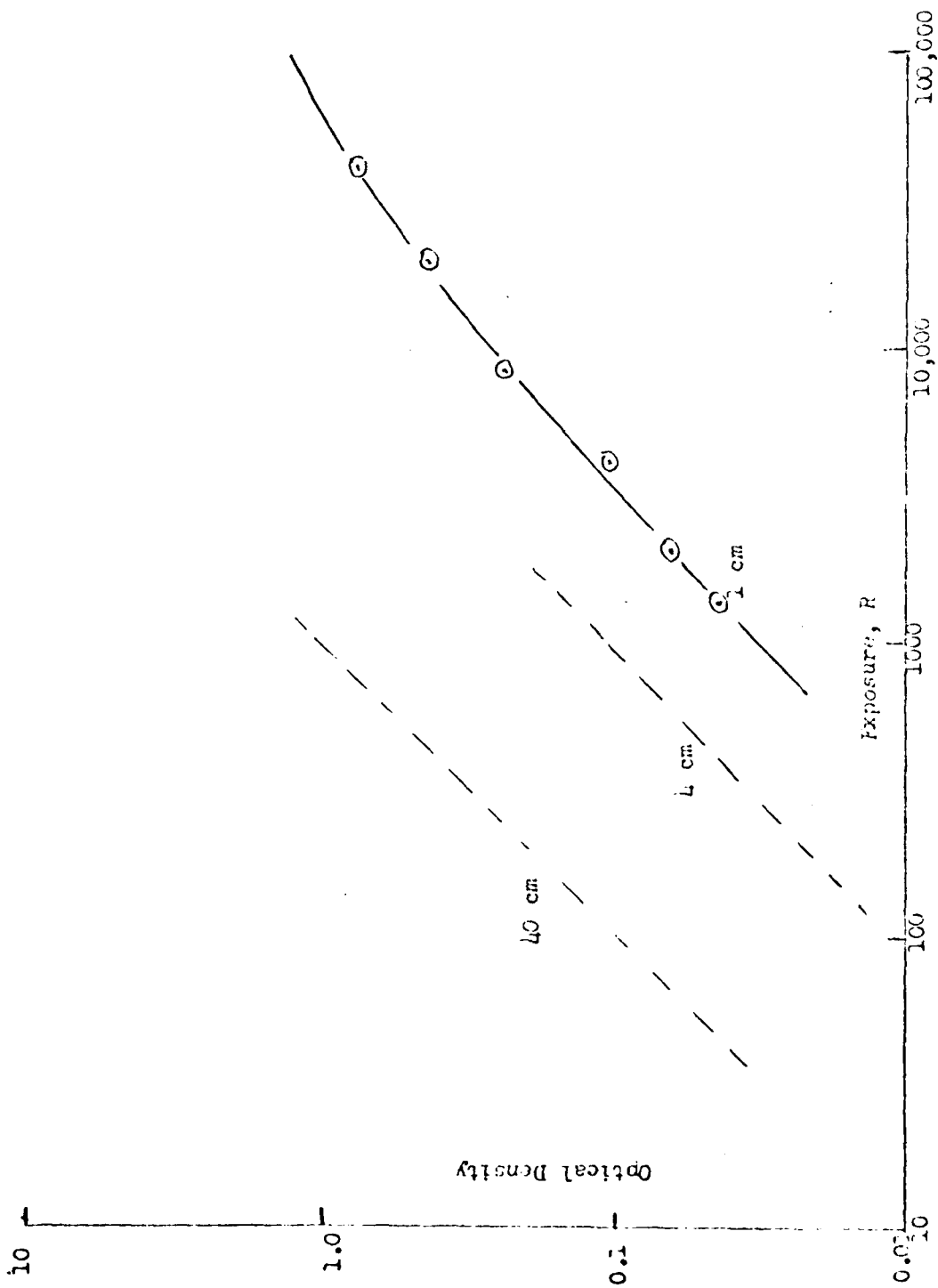

Figure 5.32.  $\beta$  Center absorption as a function of radiation exposure for a 1 cm length of LiF

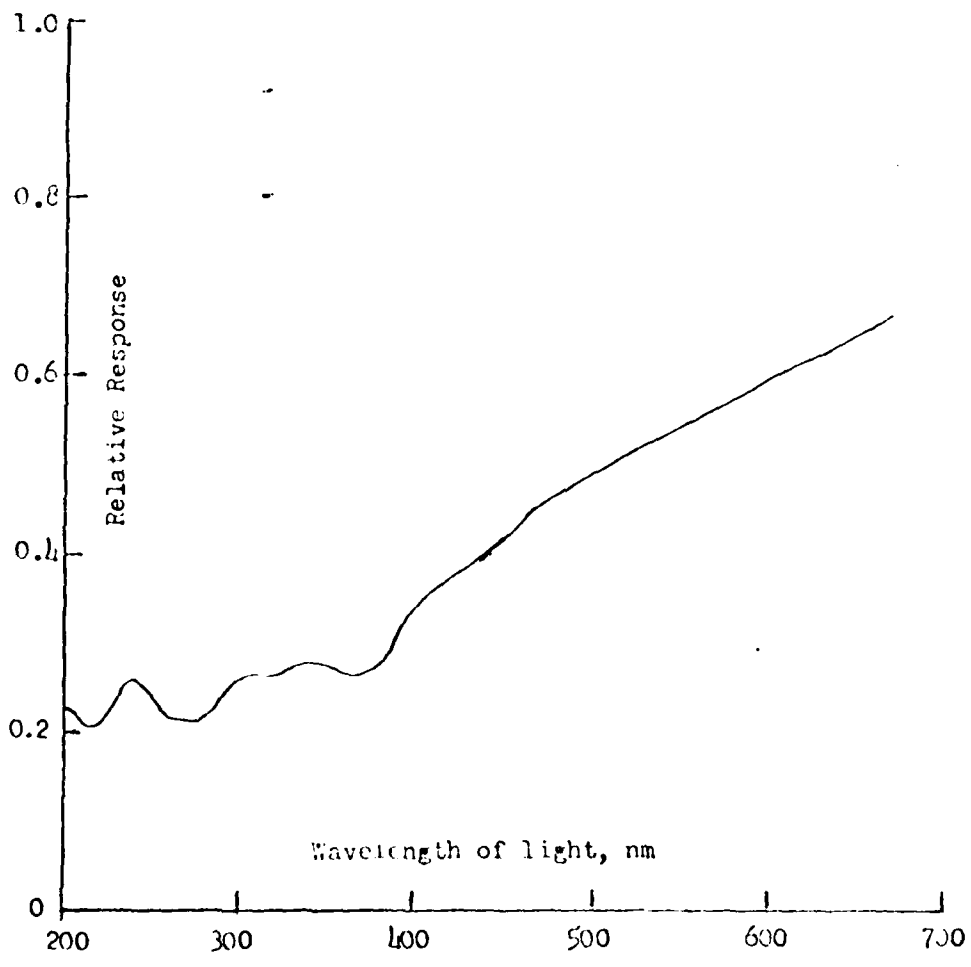

Figure 6.4. Response of photodiode to short wavelength light.  
Hamamatsu S1336-5R2A, S/N 383

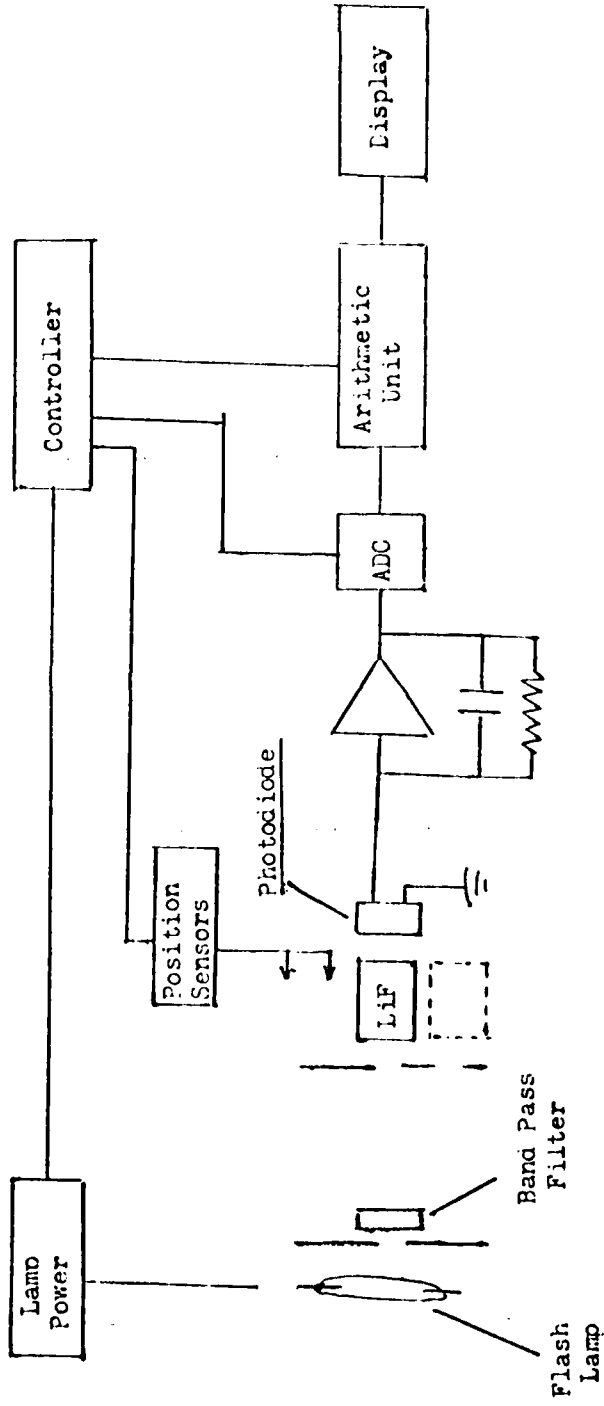

Figure 7.1. Block Diagram of a Possible Working System.

FILMED  
3-8