

AD-A110 647

FOREIGN TECHNOLOGY DIV WRIGHT-PATTERSON AFB OH

F/G 9/1

BULLETIN OF THE HIGHER EDUCATIONAL INSTITUTE, ELECTROMECHANICS --ETC(U)

JAN 82

UNCLASSIFIED

FTO-ID(RS)T-1317-81

NL

1 - 1
AD-A110 647



END
DATE
FILMED
3 82
DTIC

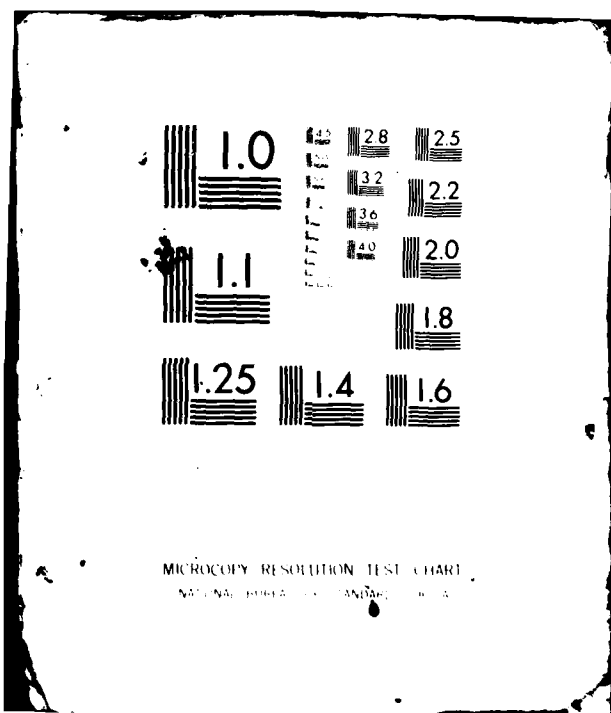

MICROCOPY RESOLUTION TEST CHART
NATIONAL BUREAU OF STANDARDS-1963-A

2

AD A110647

FOREIGN TECHNOLOGY DIVISION

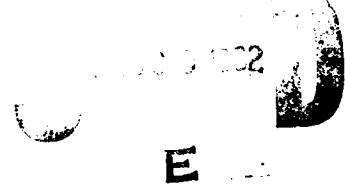

BULLETIN OF THE HIGHER EDUCATIONAL INSTITUTE, ELECTROMECHANICS

(Selected Articles)

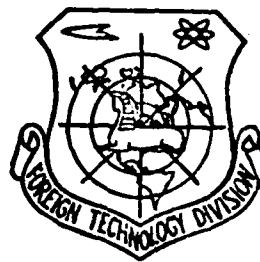

DTIC FILE COPY

Approved for public release;
distribution unlimited.



82 02 08 070

EDITED TRANSLATION

FTD-ID(RS)T-1317-81

5 January 1982

MICROFICHE NR: FTD-81-C-002059

BULLETIN OF THE HIGHER EDUCATIONAL INSTITUTE, ELECTROMECHANICS
(Selected Articles)

English pages: 20

Source: Izvestiya Vysshikh Uchebnykh Zavedeniy, Elektromekhanika,
Nr. 10, October 1969, pp. 1120-1125, Nr. 12, December 1969,
pp. 1331-1336

Country of origin: USSR

Translated by: Bernard L. Tauber

Requester: USAMICOM

Approved for public release; distribution unlimited.

THIS TRANSLATION IS A RENDITION OF THE ORIGINAL FOREIGN TEXT WITHOUT ANY ANALYTICAL OR EDITORIAL COMMENT. STATEMENTS OR THEORIES ADVOCATED OR IMPLIED ARE THOSE OF THE SOURCE AND DO NOT NECESSARILY REFLECT THE POSITION OR OPINION OF THE FOREIGN TECHNOLOGY DIVISION.

PREPARED BY:

TRANSLATION DIVISION
FOREIGN TECHNOLOGY DIVISION
WP.AFB, OHIO.

FTD-ID(RS)T-1317-81

Date 5 Jan 19 82

3. BOARD ON GEOGRAPHIC NAMES TRANSLITERATION SYSTEM

Block	Italic	Transliteration	Block	Italic	Transliteration
А а	<i>а</i>	A, a	Р р	<i>Р р</i>	R, r
Б б	<i>б</i>	B, b	С с	<i>С с</i>	S, s
В в	<i>в</i>	V, v	Т т	<i>Т т</i>	T, t
Г г	<i>г</i>	G, g	У у	<i>У у</i>	U, u
Д д	<i>д</i>	D, d	Ф ф	<i>Ф ф</i>	F, f
Е е	<i>е</i>	Ye, ye; E, e*	Х х	<i>Х х</i>	Kh, kh
Ж ж	<i>ж</i>	Zh, zh	Ц ц	<i>Ц ц</i>	Ts, ts
З з	<i>з</i>	Z, z	Ч ч	<i>Ч ч</i>	Ch, ch
И и	<i>и</i>	I, i	Ш ш	<i>Ш ш</i>	Sh, sh
Й й	<i>й</i>	Y, y	Щ щ	<i>Щ щ</i>	Shch, shch
К к	<i>к</i>	K, k	Ъ ъ	<i>Ъ ъ</i>	"
Л л	<i>л</i>	L, l	Ы ы	<i>Ы ы</i>	Y, y
М м	<i>м</i>	M, m	Ь ь	<i>Ь ь</i>	'
Н н	<i>н</i>	N, n	Э э	<i>Э э</i>	E, e
О о	<i>о</i>	O, o	Ю ю	<i>Ю ю</i>	Yu, yu
П п	<i>п</i>	P, p	Я я	<i>Я я</i>	Ya, ya

*ye only, after vowels, and after ъ, ы; e elsewhere.
When transliterated as *ë* in Russian, transliterate as *yë* or *ë*.

RUSSIAN AND ENGLISH TRIGONOMETRIC FUNCTIONS

Russian	English	Russian	English	Russian	English
sin	sin	sh	sinh	arc sh	sinh ⁻¹
cos	cos	ch	cosh	arc ch	cosh ⁻¹
tg	tan	th	tanh	arc th	tanh ⁻¹
ctg	cot	cth	coth	arc cth	coth ⁻¹
sec	sec	sch	sech	arc sch	sech ⁻¹
cosec	csc	csch	csch	arc csch	csch ⁻¹

Russian English

rot curl
lg log

THE USE OF SELF-TUNING CIRCUITS TO PROVIDE THE QUASI-OPTIMUM CHARACTERISTICS OF COMBINED-ADJUSTMENT SERVO SYSTEMS

B. V. Novoselov

I. General

The use of combined adjustment in servo systems (Fig. 1) permits attaining the complete or partial invariance of the values $\theta(t)$ from the input effect (VV) $\theta_1(t)$. On Fig. 1 $K_1(p)$, $K_2(p)$ - the transfer functions of the elements of a combined-adjustment servo system (SSKR); $n(p)$, $U_n(p)$, conditional interference operators; $\varphi(p)$ - the transfer function of the compensating device (KU).

From the theory and practice of the SSKR it is known that:

1. In the absence of interference $n(t)$, $U_n(t)$ and with the satisfaction of condition

$$\varphi(p) = \frac{1}{K_2(p)} \quad (1.1)$$

the complete invariance of $\theta(t)$ relative to $\theta_1(t)$ is ensured.

2. If (1.1) is ensured, the interference $n(t)$ passes completely in the entire frequency band to the error of the SSKR. To ensure high accuracy of the SSKR it is necessary to filter $n(t)$ out of $\theta_1(t)$. As a practical matter, this is possible only in the case of nonintersecting spectra $\theta_1(t)$ and $n(t)$ [1].

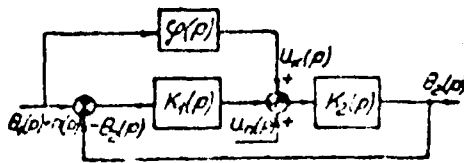

Fig. 1. Structural diagram of SSKR.

3. To reduce the influence of $U_n(t)$ on the error of the SSKR the gain of the element $K_2(p)$ should be selected sufficiently small.

4. The presence of a polynomial in the denominator of the KU transmission function $\varphi(p)$ leads to a steep drop in the frequency characteristic of a closed SSKR beyond the cut-off frequency. Proceeding from the conditions of high precision and operating speed of the SSKR when working out a useful VV, it is desirable to ensure small values, and from the viewpoint of high noise immunity - increased values of the coefficients of the denominator polynomial $\varphi(p)$.

5. Within the limits of physical feasibility $\varphi(p)$ of the SSKR possesses increased oscillation with a change in VV in comparison with a system without a KU. This is explained by the following. If without the introduction of a KU with VV $\theta_1(t) = 1(t)$ on the output of the system we had $\theta_2(t) = h(t)$, then with the introduction to the input $K_1(p)$ KU $\varphi(p) = \varphi p$, the equivalent VV

$$\theta_{10}(t) = 1(t) + \varphi \delta(t), \quad (1.2)$$

operates on the input of the SSKR and on the output of the SSKR $\theta_2(t)$ is expressed

$$\theta_{20}(t) = h(t) + \varphi \frac{d\theta_2(t)}{dt} = h(t) + \varphi \omega(t), \quad (1.3)$$

where $\delta(t)$ is the impulse function; $h(t)$ - the transition function; $\omega(t)$ - the weight function.

It is known [2] that $\omega(t)$ has at least one extremum even with the presence of only some real roots of the characteristic equation of a closed SSKR.

Frequently in practice SSKR's work out VV's of the type

$$\theta_{i,r}(t) = \theta_{i,r}(t) + \Delta\theta_{i,r}(t) + n(t), \quad (1.4)$$

where $\theta_{i,r}(t)$ - a typical useful VV; $\Delta\theta_{i,r}(t)$ - an unfavorable VV (changes of useful VV with great accelerations); $n(t)$ - a stationary random function of time (interference).

Here, it is required to ensure the maximum possible accuracy in working out $\theta_{i,r}(t)$ of the type $\theta_{i,r}(t) = \Omega_{i,r} \theta_{i,r}(t) = \frac{\varepsilon_1 t^2}{2}$; $\theta_{i,r}(t) = \theta_{i,m} \sin \omega t$ ($\Omega_{i,r}$ - velocity, ε_1 - acceleration at the input of the SSKR), high noise immunity of the SSKR and quality free transition process and transition process when working out $\Delta\theta_{i,r}(t)$ by physically realizable elements of the main circuit of the SSKR and KU.

In this work, the effect of the parameters of the KU on the quality of operation of the SSKR is examined using a specific example and the necessity for the input of self-tuning circuits (KSN) of compensating signals (KS) to assure quasi-optimum characteristics of the SSKR under various operating modes of the SSKR is shown.

II. Analysis of the Effect of the KU Parameters on the Quality of the SSKR

Assume that as the result of a synthesis in accordance with the quality of a free transition process a transmission function of an open system without a KU is obtained

$$K(p) = K_1(p)K_2(p) = \frac{K(1+T_2p)}{p(1+T_1p)(1+T_3p)} = \frac{158(1+0.289p)}{p(1+1.2p)(1+0.0138p)} \quad (2.1)$$

to ensure complete invariance with $K_1(p) = 1$, it is necessary to ensure

$$\varphi(p) = \frac{1}{K(p)} = \frac{p(1+T_1p)(1+T_3p)}{K(1+T_2p)} \quad (2.2)$$

In practice, it is usually sufficient to compensate for the static θ_{sm} , kinetic θ_k and dynamic θ_d errors. Since the system being examined possesses astatism of the first order, $\theta_{cm} = 0$. To compensate for $\theta_{sm}, \theta_k, \theta_d$ it is necessary to make the KU with a transmission function

$$\varphi(p) = K_1 p^2 \frac{1 + T_1 p}{1 + T_2 p} \quad (2.3)$$

The transmission function of a closed SSKR relative to $\theta_{1r}(p)$

$$\Phi(p) = \frac{K(p)[1 + T_1 p]}{1 + K(p)} = \frac{d_0 p^3 + d_1 p^2 + d_2 p + d_3}{a_0 p^4 + a_1 p^3 + a_2 p^2 + a_3 p + a_4} \quad (2.4)$$

where

$$\begin{aligned} d_0 &= 45.68 K_1 \alpha T_1; & d_1 &= (158 K_1 \alpha T_1 + 45.68 T_1 + 45.68 K_1 \alpha); \\ d_2 &= 158 T_1 + 158 K_1 \alpha + 45.68; & d_3 &= 158; & a_0 &= 0.0165 T_1; \\ a_1 &= 0.0165 + 1.21 T_1; & a_2 &= 1.21 + 46.68 T_1; \\ a_3 &= 46.68 + 158 T_1; & a_4 &= 158. \end{aligned}$$

The transmission function of the error relative to $\theta_{1r}(p)$

$$\Phi_0(p) = 1 - \Phi(p) = \frac{a_0 p^4 + (a_1 - d_0) p^3 + (a_2 - d_1) p^2 + (a_3 - d_2) p}{a_0 p^4 + a_1 p^3 + a_2 p^2 + a_3 p + a_4} \quad (2.5)$$

With a slowly changing $\theta_{1r}(t)$ the expansion of a rational-fractional function $\Phi_0(p)$ into a Maclaurin series is valid

$$\begin{aligned} \Phi_0(p) &= \Phi_0(0) + \frac{p}{1!} \Phi_0'(0) + \frac{p^2}{2!} \Phi_0''(0) + \dots + \frac{p^n}{n!} \Phi_0^{(n)}(0) + \dots = \\ &= C_0 + C_1 p + C_2 p^2 + C_3 p^3 + \dots + C_n p^n + \dots \end{aligned} \quad (2.6)$$

where C_0, \dots, C_n - the error coefficients which are determined from the dependences [3]:

$$\begin{aligned}
C_0 &= \lim_{p \rightarrow 0} \Phi_n(p), \\
C_1 &= \lim_{p \rightarrow 0} \frac{1}{p} [\Phi_n(p) - C_0], \\
C_2 &= \lim_{p \rightarrow 0} \frac{1}{p^2} [\Phi_n(p) - C_0 - C_1 p], \\
&\dots \dots \dots \\
C_n &= \lim_{p \rightarrow 0} \frac{1}{p^n} \left[\Phi_n(p) - \sum_{l=0}^{n-1} C_l p^l \right].
\end{aligned}
\tag{2.7}$$

Work [3] shows the validity of the expansion of (2.6) for sinusoidal VV's with frequencies which lie in the interval from zero to cutoff frequency of the frequency characteristic of the SSKR, and for exponential VV's when the time constant of the VV is greater than the time constant of the reaction of the SSKR by one discontinuity.

To ensure $\theta_s=0$, $\theta_0=0$ it is necessary to satisfy the conditions $C_1 = 0$, $C_2 = 0$. (2.8)

Simultaneously, satisfaction of $C_1 = 0$, $C_2 = 0$ requires ensuring the conditions

$$\begin{aligned}
K_1 \alpha &= K_1 \frac{T_4}{T_0} = \frac{1}{158}, \\
K_1 &= \frac{T_0 + 0,925}{158 T_0} \dots
\end{aligned}
\tag{2.9}$$

Figure 2 presents graphs $K_1 = f(T_5)$, $T_4 = f(T_5)$, $\alpha = f(T_5)$, the points of which correspond to the parameters of the KU which ensure $\theta_s=0$, $\theta_0=0$.

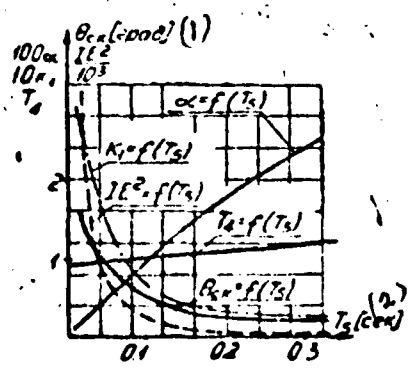

Fig. 2. Calculation graphs of SSKR parameters.
KEY: (1) Degrees; (2) Seconds.

In accordance with (1.4), (1.5) the introduction the KU increases the oscillation of the system when working out $\Delta\theta_1(t)$. Therefore, it is necessary to investigate the dependence of the integral quadratic estimate

$$IE^2 = \int_0^{\infty} \theta_1^2 dt$$

on the parameters of the KU.

For a rational-fractional function of the type (2.4) it is convenient to determine IE^2 from the dependence [4]

$$IE^2 = \frac{\Delta G}{2a_0 \Delta H}, \quad (2.10)$$

where

$$\Delta H = \begin{vmatrix} a_1 & a_0 & 0 & \dots & 0 & 0 \\ a_2 & a_1 & a_0 & 0 & 0 & 0 \\ a_3 & a_2 & a_1 & a_0 & 0 & 0 \\ \dots & \dots & \dots & \dots & \dots & \dots \\ 0 & \dots & \dots & \dots & \dots & a_n \end{vmatrix}; \quad (2.11)$$

$$\Delta G = \begin{vmatrix} d_0^2 & a_0 & 0 & \dots & 0 \\ -(d_1^2 - 2d_0 d_2) & a_2 & a_1 & \dots & 0 \\ d_2^2 - 2d_1 d_3 + 2d_0 d_4 & a_4 & a_3 & \dots & 0 \\ \dots & \dots & \dots & \dots & \dots \\ (-1)^{k-1} (d_{k-1}^2 + 2 \sum_{l=1}^{k-1} (-1)^l d_{k+l-1} d_{k-l-1}) & \dots & \dots & \dots & \dots \\ \dots & \dots & \dots & \dots & \dots \\ (-1)^{n-1} d_{n-1}^2 & \dots & \dots & \dots & a_n \end{vmatrix} \quad (2.11)$$

After the substitution of numerical values and a number of transformations we have

$$IE^2 = \frac{1,036 \cdot 10^6 T_5^4 + 4,856 \cdot 10^8 T_5^3 + 1,34 \cdot 10^8 T_5^2 + 2,317 \cdot 10^4 T_5 + 611}{4,45 \cdot 10^6 T_5^3 + 1,316 \cdot 10^7 T_5^2 + 342 T_5^2 + 4,65 T_5} \quad (2.12)$$

As follows from (2.12), IE^2 is a function of T_5 . The optimum value of T_5 could be determined proceeding from the condition of equality to zero of the partial derivative

$$\frac{d(IE^2)}{dT_5} = 0, \quad (2.13)$$

but in this case it would be necessary to solve an equation of the 6th power, which is too laborious.

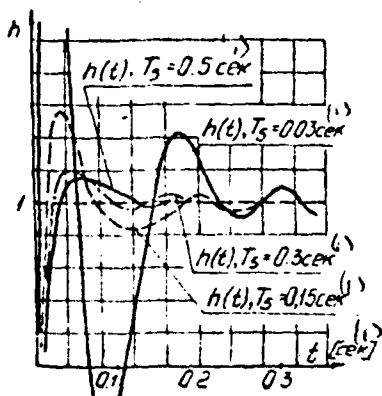

Fig. 3. Calculation graphs of transitional processes.

KEY: (1) Second.

Figure 2 presents the dependence $IE^2 = f(T_5)$ for values of parameters of KU which lie on trajectories which satisfy the conditions which ensure $\sum_0^2 C_i = 0$.

Figure 3 presents graphs of the transitional processes $\theta_2(t)$ with $\theta_1(t) = 1(t)$ for a number of combinations of KU parameters which ensure $\sum_0^2 C_i = 0$

eters which ensure $\sum_0^2 C_i = 0$

a) $T_5 = 0.03,$	$T_4 = 0.955,$	$K_1 = 0.202,$	$\alpha = 0.0314;$
b) $T_5 = 0.15,$	$T_4 = 1.075,$	$K_1 = 0.045,$	$\alpha = 0.14;$
c) $T_5 = 0.3,$	$T_4 = 1.225,$	$K_1 = 0.0258,$	$\alpha = 0.245$
d) $T_5 = 0.5,$	$T_4 = 1.425,$	$K_1 = 0.018,$	$\alpha = 0.351.$

If $\theta_1(t)$ and $n(t)$ are correlation independent, the mutual spectral density equals zero and the mean value of the square of the error from interference $n(t)$ is expressed

$$\overline{\theta_n^2(t)} = \frac{1}{\pi} \int_0^{\infty} |\Phi(j\omega)|^2 G_n(\omega) d\omega, \quad (2.14)$$

where $G_n(\omega)$ is the spectral density of interference $n(t)$.

In those cases where $\Phi(j\omega)$ and $G_n(\omega)$ are rational-fractional functions, $\overline{\theta_n^2(t)}$ can be calculated in the form of an explicit function of the parameters of the system similar to the calculation of IE^2 , using tables of integrals presented in [5].

With $G_n(\omega) = N^2 = 0.01 \overline{\theta_n^2(t)}$ is expressed

$$\begin{aligned} \overline{\theta_n^2(t)} &= \frac{1}{2\pi} \int_{-\infty}^{\infty} \frac{(d_0 p^3 + d_1 p^2 + d_2 p + d_3)^2 N^2}{(a_0 p^4 + a_1 p^3 + a_2 p^2 + a_3 p + a_4)^2} dp = \\ &= \frac{N^2}{2\pi} \int_{-i\infty}^{+i\infty} \frac{L(-p)L(p)}{M(-p)M(p)} dp, \end{aligned} \quad (2.15)$$

where

$$\begin{aligned} L(p) &= d_0 p^3 + d_1 p^2 + d_2 p + d_3, \\ M(p) &= a_0 p^4 + a_1 p^3 + a_2 p^2 + a_3 p + a_4. \end{aligned}$$

In accordance with [5] for this case

$$\begin{aligned} \overline{\theta_n^2(t)} &= N^2 \frac{d_3^2(-a_0^2 a_4 + a_0 a_1 a_2) + (d_2^2 - 2d_1 d_3) a_0 a_1 a_4 + \rightarrow}{2a_0 a_4 (-a_0 a_3^2 - a_1^2 a_4 + a_1 a_2 a_3)} \\ &+ \rightarrow (d_1^2 - 2d_0 d_2) a_0 a_3 a_4 + d_0^2 (-a_1 a_4^2 - a_2 a_3 a_4) \end{aligned} \quad (2.16)$$

The root-mean-square error caused by the interference is expressed

$$\theta_{\text{ex}} = \sqrt{\overline{\theta_n^2(t)}}. \quad (2.17)$$

Figure 2 presents the dependence $\theta_{\text{ex}} = f(T_5)$. From an analysis of the results of the calculation which was conducted it follows that:

1. The compensation for steady values of θ_{ex} , θ_0 can be accomplished with different combinations of KU parameters, but which satisfy conditions (2.9).
2. Oscillation and noise immunity of SSKR depend to a considerable degree on the value of T_5 .
3. The selection of stationary KU parameters which ensure the simultaneous optimum characteristics of the SSKR when working out $\theta_{1r}(t)$, which is mixed with $n(t)$ and when working out $\Delta\theta_1(t)$, is virtually impossible. The necessity arises to change the KU parameters in the VV function by the input of the KSN.

III. On the Introduction of KSN into SSKR

As follows from (1.6), in the general case the sum of signals operates on the input of the SSKR: the useful VV $\theta_{1,r}(t)$, unfavorable VV $\Delta\theta_1(t)$, and interference $n(t)$. In accordance with the requirements posed in Section I $\theta_{r,m}=0$, $\theta_r=0$, $\theta_s=0$ when working out $\theta_{1,r}(t)$ of the type $\theta_{1,r}(t) = \theta_1 t$;

$$\theta_{1,r}(t) = \frac{\theta_1 t^2}{2}; \quad \theta_{1,r}(t) = \theta_{1,m} \sin \omega t$$

(where ω - comparatively low frequency). Consequently, the dynamic error of the SSKR when working out $\theta_{1,r}(t) + n(t)$ is caused only by the action of $n(t)$. In the transitional modes when working out $\Delta\theta_1(t)$ the error attains large values. From Section II it follows that when working out $\theta_{1,r}(t)$ it is desirable to have small values of T_5 , and with the action of $n(t)$ and $\Delta\theta_1(t)$ large values of T_5 .

In the diagram of Fig. 4a KSN1 ensures the maintenance of the relationship

$$K_1 \alpha = K_1 \frac{T_4}{T_5} = \frac{1}{158}$$

and KSN2 ensures the change in T_5 in accordance with the linear law in the error function of the SSKR.

In the scheme in Fig. 4b the signal of the master tachogenerator (TG) goes through the tuning potentiometer (PN) to a differentiator (DK) and to the KSN which consists of two filters F1 and F2 and two phase discriminators FD1, FD2. With the action of $\theta_{1,r}(t)$ T_5 decreases and with the action of $\Delta\theta_1$ or the presence of $n(t)$ T_5 increases with the corresponding change in K_1 , T_4 .

The construction of the KSN, depending on the requirements imposed on the SSKR, may also be different. For example, at points in time when $\theta_{1,r}(t) + n(t)$ operates the SSKR behaves as a narrow-band system and with the action $\Delta\theta_1(t)$ the passband of the SSKR expands with a decrease in T_5 .

Conclusions

The precision, oscillation, and noise immunity of the SSKR depend to a significant degree on the parameters of the KU. The selection of stationary parameters of the KU which ensure the quasi-optimum characteristics of the SSKR in various operating modes is practically impossible.

The expediency of using self-tuning circuits to ensure the quasi-optimum characteristics of the SSKR is shown.

BIBLIOGRAPHY

1. Удерман Э. Г., «О свойствах и расчете комбинированных следящих систем, удовлетворяющих условиям инвариантности», Известия АН СССР, Энергетика и автоматика, 1962, № 6.
2. Бессекерский В. А., Попов Е. П., Теория систем автоматического регулирования, Наука, М, 1966.
3. Терсков В. Г., Вопросы расчета и проектирования систем с комбинированным управлением, Труды МАИ, вып. № 134, Оборонгиз, 1967.
4. Schneider F., «Geschlossene Formeln zur Berechnung der quadratischen und Zeitbeschwerten quadratischen Regelfläche für kontinuierliche und diskrete Systeme», Regelungstechnik, 1966, № 14.
5. Ньютон Д., К., Гуал Л. А., Кайзер Дж. Ф., Теория линейных следящих систем, Физматгиз, 1961.

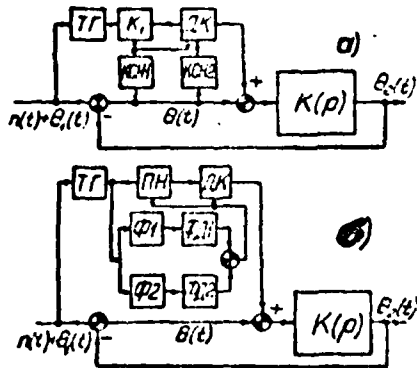

Fig. 4. Diagram of SSKR with KSN KS.

THE PRINCIPLE FOR CONSTRUCTING SELF-TUNING CIRCUITS FOR COMBINED ADJUSTMENT SERVO SYSTEMS

B. V. Novoselov

I. Statement of the Problem

The employment of combined-adjustment servo systems (SSKR) permits theoretically ensuring the complete compensation of steady-state errors when working out a specific type of input effects (VV). However, the non-steady-state nature of the parameters and nonlinearity of the characteristics of SSKR elements cause the disruption of the conditions for the compensation of component errors and, consequently, an increase in the error, frequently to impermissible values.

Let the SSKR be made in accordance with the scheme in Fig. 1a, where

$$K(p) = \frac{K}{p(1 + T_1 p)(1 + T_2 p)}; \varphi(p) = \varphi p + \varphi' p^2. \quad (1.1)$$

The expressions for the kinetic θ_k and dynamic θ_d errors and the conditions for their complete compensation

$$\theta_k = \frac{1 - K\varphi}{K} \Omega; \varphi = \frac{1}{K}; \theta_d = \frac{T_1 + T_2 - K\varphi'}{K}; \varphi' = \frac{T_1 + T_2}{K}. \quad (1.2)$$

With disruption of the condition $\varphi = 1/K$ (change in the gain of the SSKR K or change in KS [compensating signals] φ) $\theta_k \neq 0$ and takes the values

$$\theta_x = \frac{1 - (K \mp \Delta K)\varphi}{K \mp \Delta K} \Omega_1 = \frac{\pm \frac{\Delta K}{K}}{1 \mp \frac{\Delta K}{K}} \theta_{x0},$$

$$\theta_x = \frac{1 - K(\varphi \mp \Delta\varphi)}{K} \Omega_1 = \pm \Delta\varphi K \theta_{x0}. \quad (1.3)$$

where $\theta_{x0} = \frac{\Omega_1}{K}$ - the value of θ_x in the absence of KS.

From an analysis of (1.3) it follows that in a number of practical tasks it is necessary to introduce the automatic tuning of SSKR parameters in the function of the parameter being changed. It is expedient to accomplish the tuning of the KS since in this case there is no necessity to solve a compromise problem when ensuring high precision and stability.

II. Theory of SSKR with KSN [Self-Tuning Circuits] of KS

Figure 1b presents the structural diagram of an SSKR in which parts of the KS which are generated by differentiators (Dif 1), (Dif 2) are multiplied in product blocks (BP1), (BP2) by the output signals of integrators (I1), (I2) of the actual SSKR error, which accomplishes the required change in the KS with disruption of the conditions for the compensation of errors.

In this scheme, in essence the integral control with variable integration coefficients, which are functions of VV, is accomplished. When working out VV such control ensures the elimination of steady-state errors regardless of the reason for their appearance and does not affect the quality of free transitional processes.

The operation of the SSKR with the KSN is described by a non-linear equation with variable coefficients

$$\begin{aligned}
& T_1 T_2 \frac{d^3 \theta}{dt^3} + (T_1 + T_2) \frac{d^2 \theta}{dt^2} + \frac{d \theta}{dt} + K \theta + \\
& + K[\varphi_0 + \varphi_0(t)] \frac{d \theta_1}{dt} \int_0^t W_1' \theta dt + K[\varphi_0' + \varphi_0'(t)] \frac{d^2 \theta_1}{dt^2} \int_0^t W_1' \theta dt = \\
& = T_1 T_2 \frac{d^3 \theta_1}{dt^3} + (T_1 + T_2) \frac{d^2 \theta_1}{dt^2} - K[\varphi' + \varphi'(t)] \frac{d^2 \theta_1}{dt^2} - \\
& - K[\varphi + \varphi(t)] \frac{d \theta_1}{dt}.
\end{aligned} \tag{2.1}$$

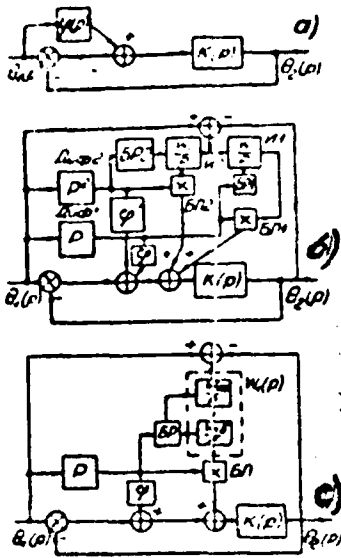

Fig. 1. Block diagram of SSKR.

Let us assume that $\varphi_0(t)$, $\varphi_0'(t)$, $\varphi(t)$, $\varphi'(t)$ - slowly changing functions, i.e., their change is insignificant during the time of effective duration of the transient characteristic of the SSKR. Then the statement of the task will be the following. At point in time $t = 0$ the conditions of compensation θ_s, θ_0 are disrupted

$$\begin{aligned}
\varphi_s &= \varphi + \varphi(t) \neq \frac{1}{K}, \\
\varphi_s' &= \varphi' + \varphi'(t) \neq \frac{T_1 + T_2}{K}.
\end{aligned}$$

The self-tuning circuits should ensure the elimination of the steady-state errors.

We introduce the designations

$$a_1(t) = W_1 \frac{d \theta_1}{dt}; \quad a_2(t) = W_1' \frac{d^2 \theta_1}{dt^2}. \tag{2.2}$$

Dividing the left and right sides of (2.1) by $a_1(t) + a_2(t)$ (the sum of $a_1(t) + a_2(t) \neq 0$ in addition as with $t = 0$) and differentiating with respect to t , we obtain

$$\begin{aligned}
& a_0(t) \frac{d^2 \theta}{dt^2} + \left[\frac{da_0(t)}{dt} + a_1(t) \right] \frac{d^2 \theta}{dt^2} + \left[\frac{da_1(t)}{dt} + a_2(t) \right] \frac{d^2 \theta}{dt^2} + \\
& + \left[\frac{da_2(t)}{dt} + a_3(t) \right] \frac{d \theta}{dt} + \left[K + \frac{da_3(t)}{dt} \right] \theta = \\
& = b_0(t) \frac{d^2 \theta_1}{dt^2} + \left[\frac{db_0(t)}{dt} + b_1(t) \right] \frac{d^2 \theta_1}{dt^2} + \\
& + \left[\frac{db_1(t)}{dt} + b_2(t) \right] \frac{d^2 \theta_1}{dt^2} + \frac{db_2(t)}{dt} \frac{d \theta_1}{dt}.
\end{aligned} \tag{2.3}$$

$$\begin{aligned}
 a_0(t) &= \frac{T_1 T_2}{a_1(t) + a_2(t)}; & a_1(t) &= \frac{T_1 + T_2}{a_1(t) + a_2(t)}; & a_2(t) &= \frac{1}{a_1(t) + a_2(t)}; \\
 a_3(t) &= \frac{K}{a_1(t) + a_2(t)}; & b_0(t) &= \frac{T_1 T_2}{a_1(t) + a_2(t)}; \\
 b_1(t) &= \frac{T_1 + T_2 - K\varphi_K'}{a_1(t) + a_2(t)}; & b_2(t) &= \frac{1 - K\varphi_K'}{a_1(t) + a_2(t)}.
 \end{aligned}$$

Equation (2.3) - an equation with variable coefficients. Its overall solution is difficult to obtain. But in view of equation (2.3) itself it is easy to establish the conditions for the compensation for individual components of the error.

With $\theta_1(t) = \Omega_1 t$ $\theta_K = 0$, if

$$\frac{db_2(t)}{dt} = \frac{d}{dt} \left[\frac{1 - K\varphi_K'}{W_1 \frac{d\theta_1}{dt} + W_1' \frac{d^2\theta_1}{dt^2}} \right] = 0. \quad (2.4)$$

With $\theta_1(t) = \frac{\varepsilon_1 t^2}{2}$ $\theta_K = 0$, if

$$\frac{db_1(t)}{dt} + b_2(t) = 0, \quad \frac{db_2(t)}{dt} = 0. \quad (2.5)$$

In the case of $\theta_1(t) = \Omega_1 t$, $\frac{d\theta_1}{dt} = \Omega_1$, $\frac{d^2\theta_1}{dt^2} = 0$, consequently, $b_2 = \frac{1 - K\varphi_K'}{W_1 \Omega_1}$, and $\frac{db_2(t)}{dt} = 0$, i.e., KSN's always ensure $\theta_K = 0$.

In the case

$$\theta_1(t) = \frac{\varepsilon_1 t^2}{2}, \quad \frac{d\theta_1}{dt} = \varepsilon_1 t, \quad \frac{d^2\theta_1}{dt^2} = \varepsilon_1,$$

consequently

$$\begin{aligned}
 b_1(t) &= \frac{T_1 + T_2 - K\varphi_K'}{W_1 \varepsilon_1 t + W_1' \varepsilon_1}; & \frac{db_2(t)}{dt} &= \frac{-W_1 \varepsilon_1 (T_1 + T_2 - K\varphi_K')}{(W_1 \varepsilon_1 t + W_1' \varepsilon_1)^2}; \\
 \frac{db_2(t)}{dt} &= \frac{-(1 - K\varphi_K') W_1 \varepsilon_1}{W_1 \varepsilon_1 t^2},
 \end{aligned}$$

i.e., KSN's ensure $\theta_p \rightarrow 0$ with $t \rightarrow \infty$.

A rather effective method for investigating SSKR's with KSN KS is the method of L. A. Zade which uses a parametric transfer function of the system [1]-[4].

If VV SSKR with variable parameters satisfies the proper conditions, it can be presented using a Fourier integral

$$\theta_1(t) = \frac{1}{2\pi} \int_{-\infty}^{+\infty} \theta_1(j\omega) e^{j\omega t} d\omega, \quad (2.6)$$

and the error of the SSKR in this case can be determined from the following relations

$$\theta(t) = \int_0^t w_0(t, \zeta) \theta_1(\zeta) d\zeta, \quad (2.7)$$

$$\theta(t) = \frac{1}{2\pi j} \int_{c-j\infty}^{c+j\infty} W_0^*(p, t) \theta_1(p) e^{pt} dp. \quad (2.8)$$

In (2.6)-(2.8) $\theta_1(j\omega)$ - is the complex relative amplitude of the spectrum of the function $\theta_1(t)$; $w_0(t, \zeta)$ - the function of the weight of SSKR error, $W_0(p, t)$ - the parametric transfer function of SSKR error.

If equation (2.1) is presented in the form

$$A(p, t) \theta(t) = B(p, t) \theta_1(t), \quad (2.9)$$

then for the case $\theta_1(t) = \delta(t - \tau)$, $\theta(t) = w_0(t, \tau)$ the parametric transfer function of the SSKR error is expressed [4]

$$W_0(p, t) = W_0(p, t)_0 + \sum_{k=1}^{k=N} W_0(p, t)_{k+1}. \quad (2.10)$$

where $W_0(p, t)_n$ — the n approximation of $W_0(p, t)$;

$$\begin{aligned}
 W_0(p, t)_0 &= \frac{B(p, t)}{A(p, t)}; \\
 W_0(p, t)_{k+1} &= \frac{1}{A(p, t)} \left[\frac{dA(p, t)}{dp} \frac{dW_0(p, t)_k}{dt} + \dots + \right. \\
 &\quad \left. + \frac{1}{n!} \frac{d^n A(p, t)}{dp^n} \frac{d^n W_0(p, t)_k}{dt^n} \right]. \tag{2.11}
 \end{aligned}$$

With slowly changing SSKR parameters, for a preliminary estimate of the quality of SSKR with KSN we can use the zero approximation $W_0(p, t)$.

For the SSKR with KSN being investigated with $\varphi_0=1, \varphi_0'=1$

$$W_0(p, t)_0 = \frac{T_1 T_2 p^4 + (T_1 T_2 - K \varphi_0') p^3 + (1 - K \varphi_0) p^2}{T_1 T_2 p^4 + (T_1 + T_2) p^3 + p^2 + K p + K \left(W_1 \frac{d^4 \theta_1}{dt^4} + W_1' \frac{d^2 \theta_1}{dt^2} \right)}. \tag{2.12}$$

With $\theta_1(t) = \varrho_1(t), \frac{d\theta_1}{dt} = \varrho_1, \frac{d^2\theta_1}{dt^2} = 0$

$$W_0(p, t)_0 = \frac{T_1 T_2 p^4 + (T_1 + T_2 - K \varphi_0') p^3 + (1 - K \varphi_0) p^2}{T_1 T_2 p^4 + (T_1 + T_2) p^3 + p^2 + K p + K W_1 \varrho_1}. \tag{2.12'}$$

With $\theta_1(t) = \frac{\varepsilon_1 t^2}{2}, \frac{d\theta_1}{dt} = \varepsilon_1 t, \frac{d^2\theta_1}{dt^2} = \varepsilon_1$.

$$W_0(p, t)_0 = \frac{T_1 T_2 p^4 + (T_1 + T_2 - K \varphi_0') p^3 + (1 - K \varphi_0) p^2}{T_1 T_2 p^4 + (T_1 + T_2) p^3 + p^2 + K p + K W_1 \varepsilon_1 t + K W_1' \varepsilon_1}. \tag{2.12''}$$

From an analysis of (2.12'), (2.12'') it follows that with the introduction of KSN:

1. $\theta_\infty=0, \theta_0 = \frac{1-K\varphi_0}{KW_1 t + KW_1'}, \theta_0=0$ with $\varepsilon_\infty = \frac{1}{K}$ and with $t \rightarrow \infty$.

2. The stability of the SSKR when working out VV is determined by the parameters of the SSKR and the parameters and sign of the VV, which requires the switching of the signs of the error integrals in the function of the sign of VV.

3. $\theta_x=0, \theta_y=0$ in any cases except $\frac{d\theta_1}{dt}=0$, if we use tuning in accordance with the first derivative of VV according to the law (Fig. 1c)

$$U_x = W_1 \int_0^{t_1} \int_0^{t_2} \theta dt. \quad (2.13)$$

To construct transient processes using $W(p, t)_0$, we can construct a series of dependences $\theta(t)$ for fixed values of $\theta_1(t)$. Each of the dependences $\theta(t)$ will have only one point which satisfies the desired point. Connecting the obtained points with a smooth curve, we obtain $\theta(t)$ [4].

III. Results of Experimental Study of SSKR with KSN KS

The power portion of a servo system is made using the following elements: amplidyne EMU-25Az, dc motor P12M.

SSKR's with KSN KS were studied in accordance with the first derivative and SSKR's with two KSN KS in accordance with the first and second derivatives from VV. As a result of the studies it was established that:

1. With operation of SSKR with one KSN:

a) $\theta_x=0$ with any $\varphi(t)$, if the frequency of change $\varphi(t)$ lies within the region of frequencies which are passed by the KSN;

b) $\theta_y=0$ with $\theta_1(t) = \frac{\epsilon_1 f^2}{2}$ after some small time interval t ;

c) the root-mean-square error θ_{ef} with $\theta_1(t) = \theta_{1m} \sin \omega t$ decreases 5-20-fold in comparison with SSKR without KSN;

d) the KSN does not influence the free transient processes;

e) for the stable operation of an SSKR with KSN it is necessary, when working out the VV, to ensure the switching of the sign $\int \theta dt$ in the function of the sign of the VV. The zone of insensitivity h of the BR [Translator's Note: expansion cannot be determined from text] should be no more than (5-7) % Ω_1 (Fig. 2a);

f) the selection of gain 11 should be selected proceeding from the minimum time of the transient process t_{1n} when working out the velocity discontinuity and the minimum θ_{cr} or θ_{max} when working out VV $\theta_1(t) = \theta_{1m} \sin \omega t$ (Fig. 2b). Figure 2c presents the dependences of $t^* = f(T_1)$, $t_s = f(1_1)$, where T_1 - the time constant of the differentiator which is connected into the circuit of the SSKR error signal.

2. With the operation of the SSKR with two KSN

a) In the modes : $\theta_1(t) = \Omega_1 t$, $\theta_2(t) = \frac{z_1 t^2}{2}$, $\theta_3(t) = \theta_{1m} \sin \omega t$, $\theta_x = 0$, $\theta_y = 0$;

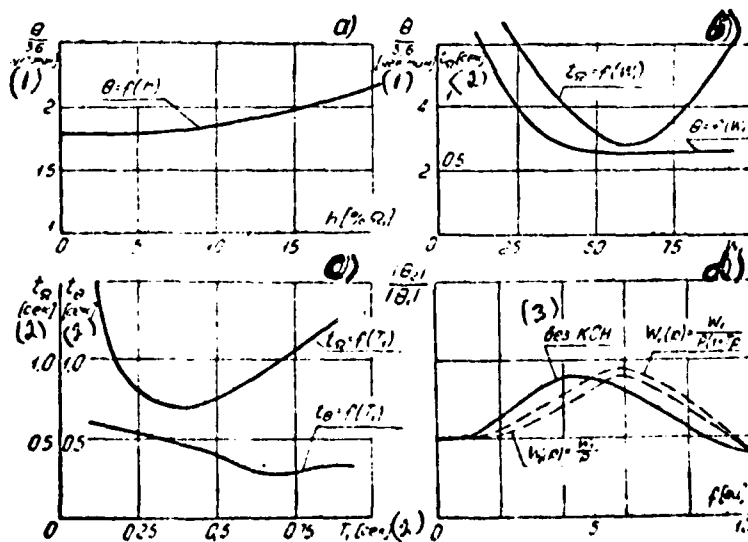

Fig. 2. Graphs of parameters of SSKR with one KSN.
 KEY: (1) Angular minute; (2) Second; (3) without.

b) with the input of KSN the quality requirements for the Dif2 are relaxed. The denominator of the transfer function of Dif2 can contain time constants which are sufficiently high in their values;

c) there are optimum values of the gain W_1, W_1' of the integrators which are estimated from the minimum θ_{CK} or θ_{MAX} with $\theta_1(t) = \theta_{1m} \sin \omega t$ and time minimum of the transient process t_s when working out the speed discontinuity Δ . In this regard, the optimum values of W_1, W_1' when estimating in accordance with the minimum θ_{CK} or θ_{MAX} are different (Fig. 3a, b);

d) the SSKR error with disturbances $\lambda(t)$ on the actuating axis decreases 5-10-fold if Ω_1 here does not equal zero and the disturbance frequency lies within the region of frequencies passed by the KSN (Fig. 3c);

e) the value of the time constant T_2 of a real Dif2 has virtually no influence on the quality of operation of the SSKR with KSN (Fig. 3d).

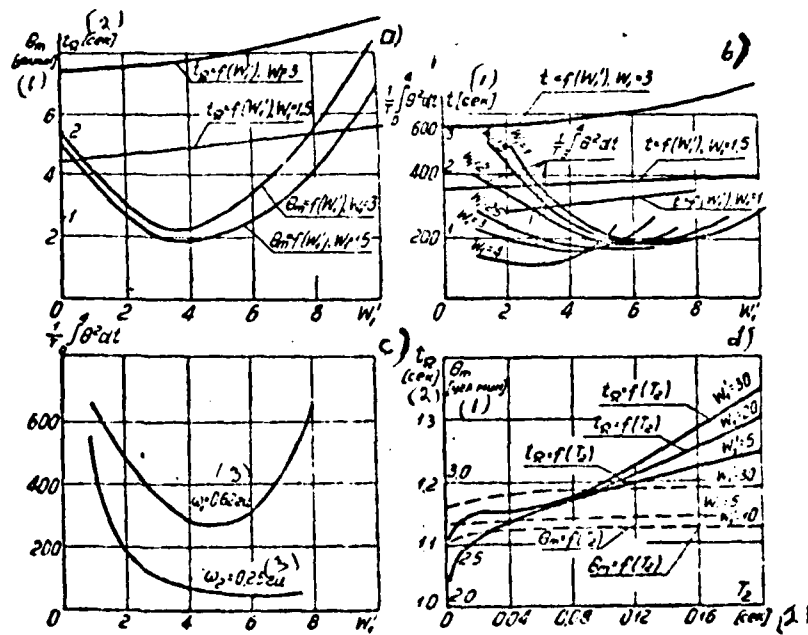

Fig. 3. Graphs of parameters of SSKR with two KSN's.
KEY: (1) Angular minute; (2) Seconds; (3) Hz.

Conclusions

1. The input of the KSN KS is an effective means for raising the precision of the SSKR.
2. The KSN KS can be employed in new developments and in SSKR being modernized since their employment does not require the reworking of the main circuit of the SSKR but envisages only the introduction of a number of additional simple devices.

BIBLIOGRAPHY

1. Zadeh L. A., Circuit analysis of linear varying parameter networks. Journ. App. Ph. vol 21, Nov. 1950.
2. Zadeh L. A., Frequency analysis of variable networks. PIRE, vol. 38, March, 1950.
3. Zadeh L. A., On stability of linear varying parameter systems. Journ. App. Ph. vol. 22, April, 1951.
4. Соколов А. В., "Линейные системы автоматического управления с переменными параметрами". Физматгиз, М., 1962.

Manuscript received
initially 19 July 1967,
after modification
22 November 1967.