

AD-A110 772

ARMY MATERIALS AND MECHANICS RESEARCH CENTER WATERTOWN MA F/6 21/5
MECHANICAL WEAR ASSESSMENT OF HELICOPTER ENGINES BY FERROGRAPHY--ETC(U)
NOV 81 C P MERHIB, S J ACQUAVIVA, R W LADNER
AMMRC-TR-81-55

UNCLASSIFIED

NL

1 1 1
1 1 1



END
DATE
FILMED
3 82
DTIC

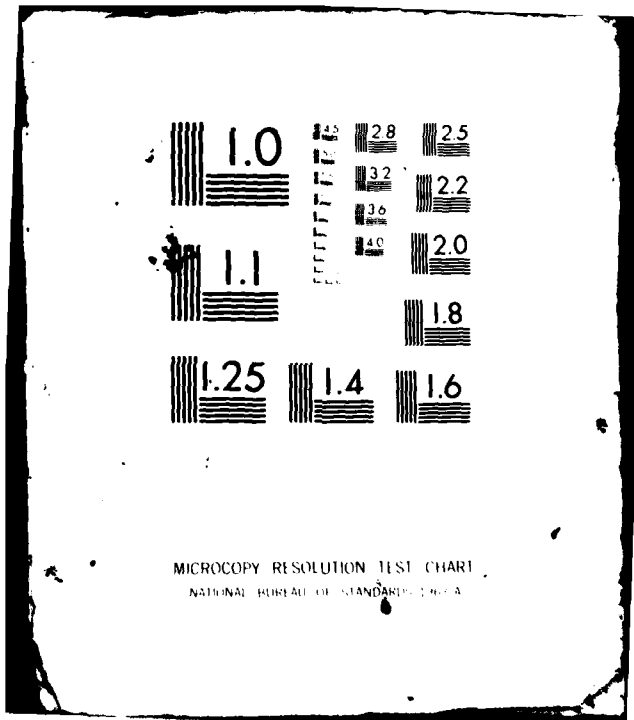

MICROCOPY RESOLUTION TEST CHART
NATIONAL BUREAU OF STANDARDS-1963-A

AD A110772

AMMRC TR 81-55

LEVEL II

12

AD

24p

**MECHANICAL WEAR ASSESSMENT
OF HELICOPTER ENGINES
BY FERROGRAPHY**

DTIC

S

FEB 11 1982

E

CHARLES P. MERHIB, SAMUEL J. ACQUAVIVA, and
ROBERT W. LADNER

MATERIALS TESTING TECHNOLOGY DIVISION

November 1981

DTIC FILE COPY

Approved for public release; distribution unlimited.

ARMY MATERIALS AND MECHANICS RESEARCH CENTER
Watertown, Massachusetts 02172

82 02 10 080

403105

The findings in this report are not to be construed as an official Department of the Army position, unless so designated by other authorized documents.

Mention of any trade names or manufacturers in this report shall not be construed as advertising nor as an official indorsement or approval of such products or companies by the United States Government.

DISPOSITION INSTRUCTIONS

Destroy this report when it is no longer needed.
Do not return it to the originator.

UNCLASSIFIED

SECURITY CLASSIFICATION OF THIS PAGE(When Data Entered)

Block No. 20

ABSTRACT

Two Ferrograph analyzers, an analytical or laboratory Ferrograph® and an On-Line (quasi-real-time) Ferrograph, were evaluated. The analytical Ferrograph was found to be an effective supplement to the spectrometric oil analysis program (SOAP) since the Ferrograph analyzes particles in the range of 1 to over 100 microns while SOAP analyzes particles below 5 microns in size. Comments are also offered on a third analyzer, the Direct Reading (DR) Ferrograph. To evaluate the analytical Ferrograph, oil samples from helicopters at Fort Devens, Massachusetts, were analyzed. One transmission was found with excessive wear particles which was later verified by SOAP.

The On-Line Ferrograph was tested in 410 hours of operation using a T53-L-13B helicopter engine in a test cell at the Corpus Christi Army Depot. After determining baseline data for the engine, defective bearings were substituted to enhance particle wear penetration. The particles subsequently generated were successfully detected by both the On-Line Ferrograph and SOAP.

UNCLASSIFIED

SECURITY CLASSIFICATION OF THIS PAGE(When Data Entered)

CONTENTS

	Page
INTRODUCTION	1
FERROGRAPHY	2
The Analytical Ferrograph	3
The Direct Reading (DR) Ferrograph	7
The On-Line Ferrograph	7
Corpus Christi Army Depot Participation	8
CONCLUSIONS	13

Accession For	
NTIS CRA&I	<input checked="" type="checkbox"/>
DTIC TAB	<input type="checkbox"/>
Unannounced	<input type="checkbox"/>
Justification	
By _____	
Distribution/ _____	
Availability Codes	
Dist	Avail and/or Special
A	



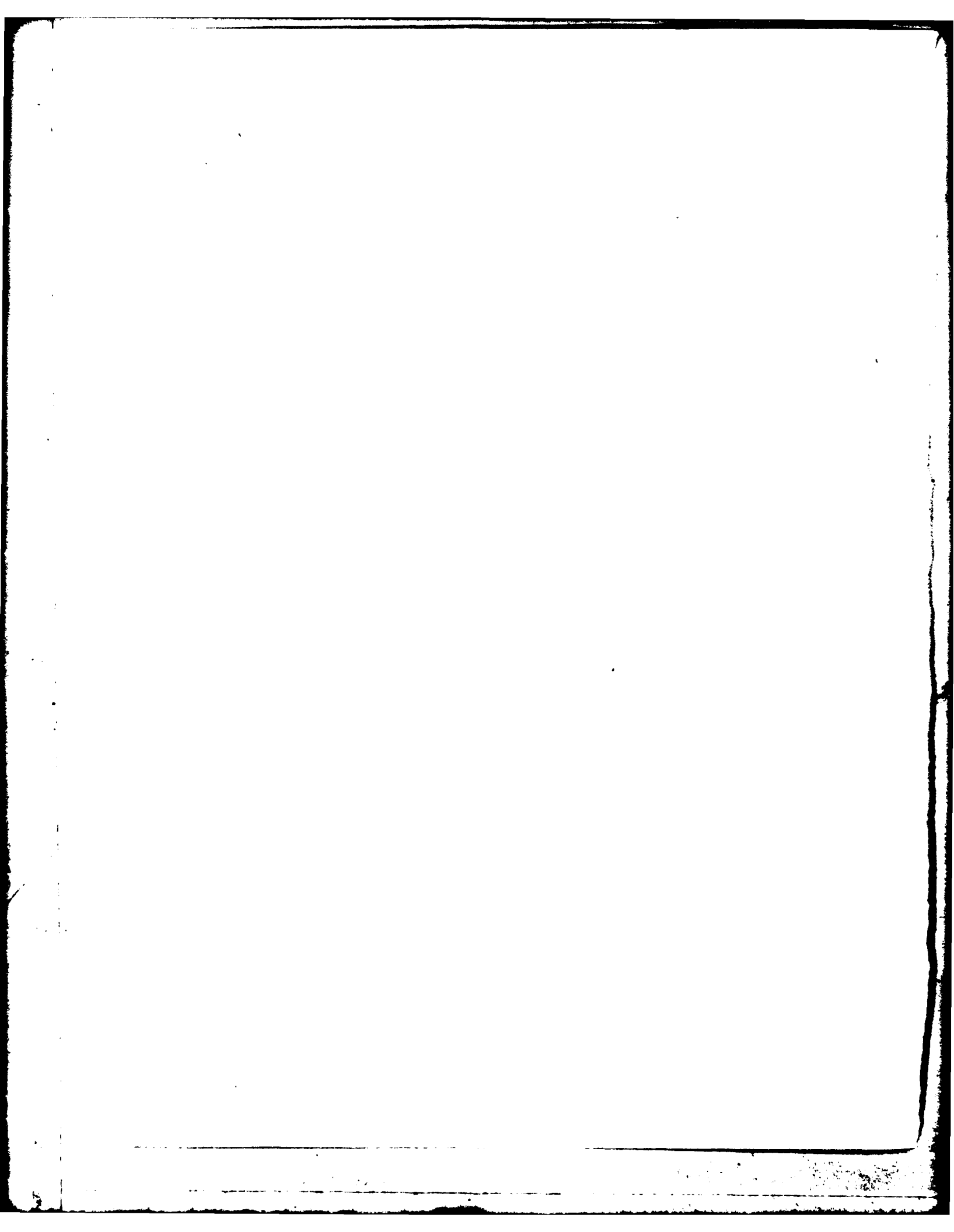

INTRODUCTION

The wear of machines in service is an unavoidable condition occurring in the best of mechanical designs. Under normal use the amount of wear is negligible; however, the cumulative effects of wear, which in reality is a gradual disintegration of the machines, eventually leads to failure. In the case of ground vehicles, such failures are costly and time consuming. In the case of an aircraft such as a helicopter, this failure can be catastrophic, resulting in the loss of lives and equipment.

To prevent such losses, Army aircraft engines are overhauled after a calculated preset number of hours of use regardless of the actual operating condition. Until recently this was considered the most effective way of insuring a safe operating aircraft; however, this "better to be safe than sorry" philosophy is inefficient and expensive. Smooth running aircraft are frequently taken out of service, needlessly overhauled, damaged in the process, then placed into service in a condition worse than before. Fixed overhaul procedures are not only expensive but cause an aircraft to be removed from service, reducing the total readiness of an aircraft operating unit.

To overcome this problem or to at least increase the time between overhauls, the concept of on-condition monitoring has been proposed. Using this concept, an aircraft would not be overhauled or repaired until necessary. To effect such a concept, reliable instrumentation would be necessary that would be capable of indicating the condition of the components involved.

On-condition monitoring systems also require intimate knowledge of tribology, the science and technology of interacting surfaces in relative motion, and the accompanying conditions of wear. In addition, early detection of progressive fatigue damage would be available. Monitoring of wear in complex equipment with an oil-lubricated system can be accomplished by several methods, the most common and oldest of which is spectrometric oil analysis and, more recently, ferrographic analysis.

The spectrometric oil analysis program has a relatively long history as a method for monitoring conditions of wear. Spectrometric oil analysis is the detection and quantitative measurement of the contaminating chemical elements in lubricating oil by spectral emission and absorption instruments. SOAP is used as a diagnostic tool to determine the internal condition of aircraft components and is mandatory for monitoring all Army aircraft lubricated systems* such as engines, transmissions, hydraulic systems, and gear boxes.

This method does have its limitations. It is effective only for those failures which are characterized by an abnormal increase in the wear metals content of the lubricating oil and which proceed toward total failure at a rate slow enough to permit corrective action to be taken after receipt of adverse reports from the laboratory. The laboratory objective is to reduce SOAP response time to 24 hours; however, there have been instances of aircraft failure during the transit time of sample or of analysis results when laboratory information to the user has arrived too late. Examples of these are failures due to oil starvation and bearing seizure. Another serious limitation is sample integrity. An improperly taken sample, whether taken too soon after an oil change or carelessly handled, causing contamination, is not representative and therefore does not indicate the true condition of the oil in the major assembly involved.

*Joint Oil Analysis Program Laboratory Manual, (Navy) NAVAIR 17-15-50; (Army) TM 38-301; (Air Force) T.O. 33-1-37.

The spectrometers generally used by the military services are of the atomic emission type. An emission spectrometer is an optical-type instrument used to determine the concentration of wear metals in lubricating fluid. The analysis is accomplished by subjecting (burning) the sample to a high voltage spark which energizes the atomic structure of the metallic elements, causing the emission of light. The emitted light is subsequently focused into the optical path of the spectrometer and separated by wave-length, converted to electrical energy and measured. The emitted light for any element is proportional to the concentration of wear metal suspended in the lubricating fluid. Results are obtained in parts per million (ppm) by weight. The military services and commercial airlines, both here and abroad, have SOAP for their aircraft.

The U S. services have combined their programs and formed a joint oil analysis program (JOAP) for the purpose of standardization in accordance with the objective, policies, and responsibilities set forth in the "Tri-Service Agreement for the Joint Oil Analysis Program" of 5 January 1976

To strive for greater accuracy, other methods are being, or have been, pursued to complement SOAP. Table 1 briefly outlines some of these methods

Table 1. WEAR MONITORING-SENSING DEVICES AND METHODS OF OIL-LUBRICATED SYSTEMS

Sensor or Method	Operating Principle	Remarks
Spectrometric Oil Analysis	Atomic emission or atomic absorption spectrometry determines concentration of elements in wear particles.	Particle size limited to those under 5 μ . Universally used.
Chip Lights and Magnetic Plugs	Used in engines, transmissions and gear boxes, collects ferromagnetic particles, completes an electrical circuit to signal excess wear condition.	Complements SOAP.
Ferrography	Collects ferromagnetic particles on slide for examination under microscope. Morphology and number of particles determine wear condition.	Particle size ranges from 1 to 150 μ . Interpretation of results still in subjective stage.
Vibration Analysis	Piezoelectric accelerometers indicate excessive vibration as an indication of trouble.	
Particle Counting	Photocell counts the pulses of signal as light beam is interrupted by particles in oil flowing past.	Correlates well with SOAP. Not easy to use, considerable experience required.
Environment One Monitor	Monitors light scattering caused by particles, light attenuation caused by chemical/thermal degradation of oil, and oil-flow rate.	Air bubbles and harmless matter can confuse readout.
K-West Screen	Monitors incidence of metallic particles on conducting wire mesh.	Wire mesh size can be varied to suit application.
X-Ray Fluorescence	Gamma radiation from a source excites particles causing X rays to be emitted.	Sensitive to total number of particles. Flyable system possible.

FERROGRAPHY

Ferrography is one of the newer methods of on-condition monitoring that appears to have a high success potential. This method permits diagnosis and prognosis of an oil-lubricated system through wear-particle detection and analysis. The Ferrograph^{®*} was

*Trademark of the Foxboro Company, Burlington, MA

developed to separate wear debris and contaminant particles from a lubricant, and to arrange them on a transparent substrate (glass slide) for microscopic examination.

The Ferrograph selected for use at AMMRC was the duplex model having the greatest versatility of the various models available. The duplex Ferrograph Analyzer consists of two particle separators; on the right is a standard Ferrograph Analyzer, and on the left a Direct Reading (DR) Ferrograph. Figure 1 shows the duplex Ferrograph Analyzer and the accompanying microscope.

The Analytical Ferrograph

The standard Ferrograph Analyzer consists of a pump to deliver the lubricant sample at a flow rate of 0.25 ml per minute, a magnet that develops a high-gradient magnetic field near its pole, and a treated transparent substrate on which the particles are deposited. The lubricant sample, diluted with a special solvent to promote the precipitation of wear particles, is pumped across the transparent substrate which is mounted at a slight incline (Figure 2). The magnetic particles adhere to the substrate and are distributed according to size. After 4 ml of oil have been pumped across the slide, a washing-and-fixing cycle removes the residual oil and causes the wear particles to adhere permanently to the slide in a band approximately 50-mm long. The slide with the deposit is called a Ferrogram (Figure 3).

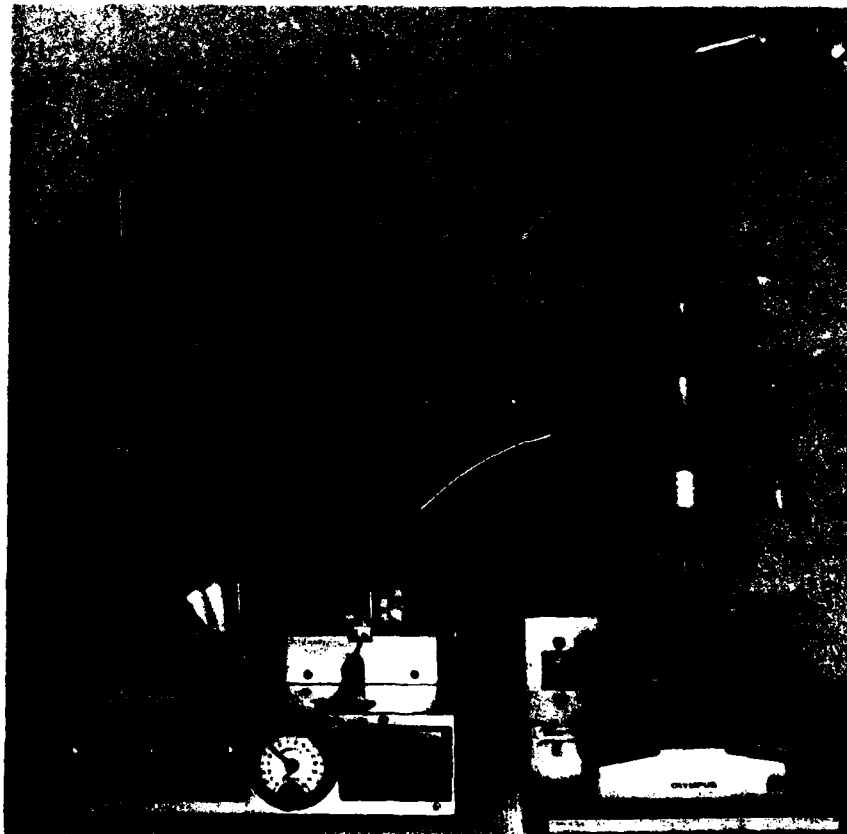

Figure 1. Duplex Ferrograph Analyzer.

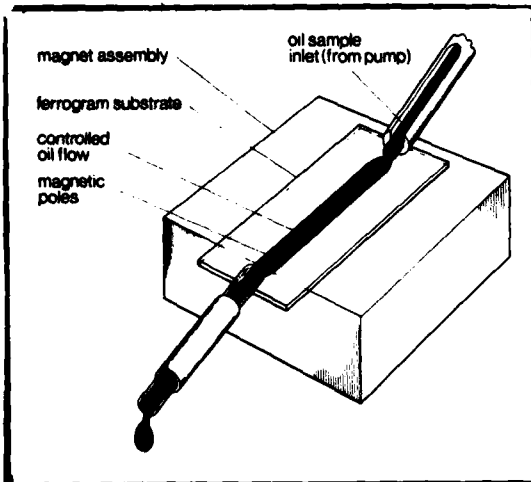

Figure 2. Ferrogram in process of being made.

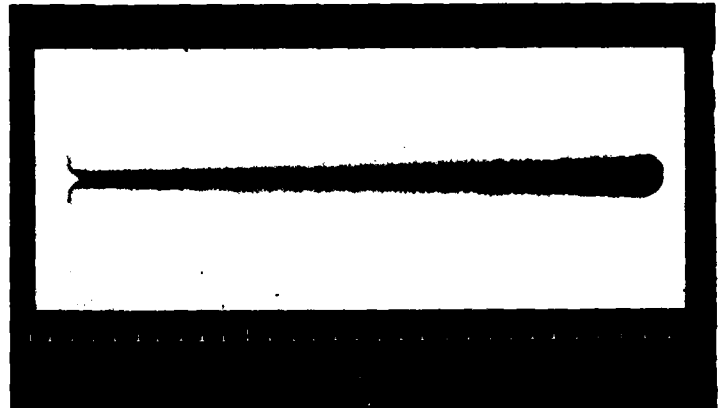

Figure 3. A typical Ferrogram.

The deposit typically contains a distribution of magnetic particles of various metals such as iron, nickel, and cobalt. Also deposited are various alloys, as well as nonferrous metals, oxides, and polymers which are weakly magnetic, either as a result of either rubbing against steel in the wearing process or because they are paramagnetic. The largest particles, usually steel, appear at the entry. As the oil flows down the Ferrogram, the size of the magnetic particles decrease continuously until only submicron-sized steel particles can be found scattered throughout the deposit. Particles resulting from severe wear situations may range in size up to several hundred microns while the smallest particles deposited may range down to 20 nanometers.

Proper exploitation of the Ferrogram involves three basic steps: (a) obtaining a representative oil sample; (b) making the Ferrogram; and (c) interpretation of the Ferrogram.

The sampling procedure is crucial. Oil samples must be taken immediately after the shutdown of equipment or within 15 minutes of shutdown to prevent particles from settling out of solution. An improperly taken sample can also introduce dirt or other contaminants and therefore confuse analytical results.

Making a Ferrogram is a relatively simple procedure that requires a certain amount of careful handling and exacting measurements. The oil sample must first be heated to 65°C, then shaken well; 3 ml of the oil must be removed and mixed with 1 ml of a fixed solution. This mixture is run through a pump and over a specially prepared glass slide to make a Ferrogram. Following a wash cycle, the Ferrogram is permitted to dry, numbered and carefully placed under the bichromatic microscope for examination and interpretation.

Interpretation, the most critical step in the process and the most important, reveals the wear condition of the component under examination. There are many interpretive techniques. The Ferrogram may be examined with a bichromatic microscope to assess the condition of a machine through direct examination of the wear particles. Certain modes of wear produce distinctive particles which indicate dangerous wear situations. Other types of particles are the result of much less serious or even innocuous wear.

For example, cutting wear (abrasive wear) can be detected before the metal content has reached one ppm. The bichromatic microscope may also be used to determine the source of wear particles. The source of the particles may often be determined by direct observation of the nature of the particles precipitated on the Ferrogram. Optical and thermal tests may be applied to the Ferrogram to differentiate between the various kinds of particles, thereby providing additional information as to their source and significance. Ferrography permits the classification of the various kinds of particles in the fluid and offers the possibility that the offending part of a malfunctioning machine may be identified without disassembly.

Particles on a Ferrogram can also be examined and analyzed in a scanning electron microscope (SEM). In combination with an energy dispersion X-ray apparatus, the SEM provides a tool for determining the elements of an individual particle.

The measurement of optical densities is another technique for analyzing Ferrograms. By observing the density changes at various locations along the Ferrogram, the amount and size distribution of particles may be obtained. If the distribution changes radically from its normal value, it is an indication that a new wear mechanism has started. In general, an accelerated buildup of particles larger than 5μ , in comparison with particles that are smaller than 2μ , signals a wear process that may result in relatively rapid failure of the equipment.

To obtain realistic oil samples, arrangements were made with maintenance personnel at Moore AAF, Fort Devens, Massachusetts, for samples from various components of helicopter lubricating systems such as engines, transmissions, gear boxes, and hydraulic systems. These components are monitored regularly, as required, in the Army's SOAP program.

It was learned later that most of the Fort Devens' samples were taken from units that had been sitting overnight, which allowed particles to settle, rather than from units that had just been shut down whose particles were still in suspension. This incurred doubt as to the representative quality of those samples. A change in sampling procedure was requested but never achieved.

Ferrograph samples were taken simultaneously with SOAP samples and sent to AMMRC for analysis. Over a six-month period, approximately 200 samples were submitted. Typical of the many samples examined was the photomicrograph in Figure 4 which shows the normal amount of wear debris accumulated after approximately eight hours of engine time.

In the course of the examination, one sample taken from the 90° gear box of UH-1H No. 69-15022 showed a high density of wear debris (Figure 5). SOAP results agreed with those obtained by Ferrography and the gear box was removed from service. Maintenance personnel at Fort Devens replaced the worn transmission and shipped it to a depot for overhaul prior to examination of the unit for corroborative evidence as to its actual wear condition. As discovered later, authorization to dismantle a transmission was a function of the depot operations and not field units. Subsequently, an attempt was made to trace the transmission to the Corpus Christi Army Depot (CCAD) without success.

The Fort Devens samples provided an opportunity for practical experience with on-line operating units and in dealing with on-line personnel, their conscientious attitude, and working restraints. It became obvious early in this effort that the Analytical Ferrograph was not an instrument for production use because of the length of time it took to make and interpret a Ferrogram, and because of the expense (\$7.50 at that time) for each kit. By contrast SOAP readings on automated equipment took a minute or two at a cost of slightly over a dollar.

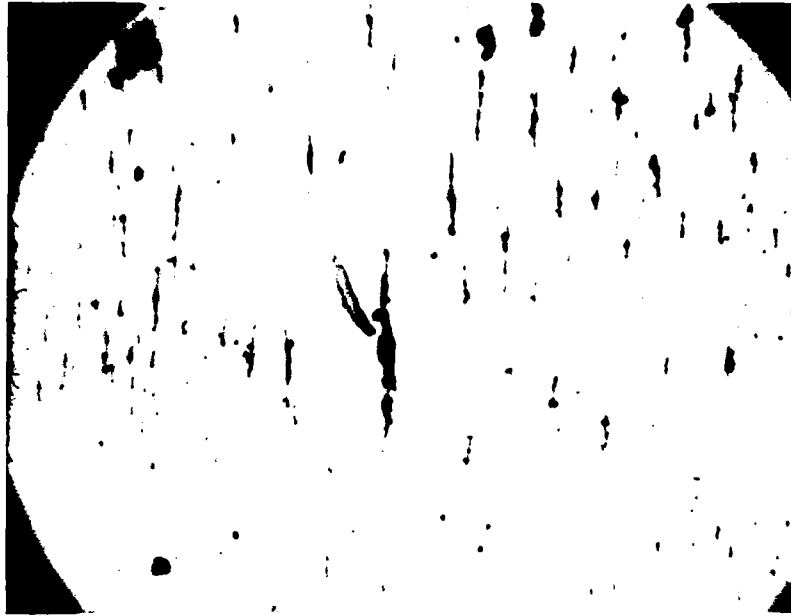

Figure 4. Typical example of wear debris.

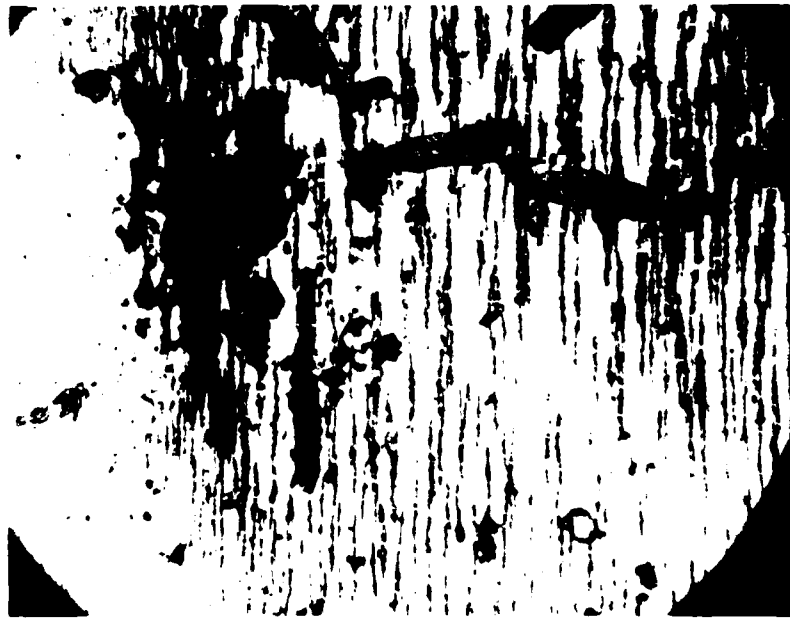

Figure 5. Wear debris from replaced transmission.

The Direct Reading (DR) Ferrograph

In the DR Ferrograph the debris is collected at two separate yet closely located positions, the large particles at one location, the small at the other. Light passing through the collection points is read out in digital form to provide readings relative to the large and small particles collected. The variability of the readings, difficulty obtaining reproducible readings, and the inability to relate the numbers to actual wear conditions negated further use of the DR Ferrograph.

The On-Line Ferrograph

Shortly after the development of the laboratory model of the Ferrograph, a Navy contract was let with Transonics, Inc. (now Foxboro Co.) to develop a model that could be flown as a real-time on-line monitoring device. The Foxboro Co. produced two models, a ground-based (test cell model) and a totally flyable model. Both work on the same principle.

The original contract called for provision of five models for field evaluation. Arrangements had been made with Navy personnel to obtain one of the models for evaluation by the Army. However, a cost overrun on the contract limited production to one model which the Navy received. The Foxboro Co., with the Navy's concurrence, made additional models available. AMMRC obtained a test cell model for use in an evaluation study on a helicopter engine at CCAD.

The purpose of the On-Line Ferrograph is to predict incipient machine failures by monitoring the concentration of metallic wear particles within a lubrication or hydraulic system. The unit consists of a sensor located on the helicopter engine and a wear analyzer located in the console room of the test cell (Figure 6). The sensor contains the hardware required to separate the wear debris from the oil and control the oil flow. The remotely located wear analyzer contains the electronic control and display unit together with an adjustable high concentration alarm that will indicate when debris levels exceed preset limits.

The wear debris is precipitated from the oil by a high gradient magnetic field, and quantitative measurement of the debris is achieved by a surface effect capacitance sensor. Since precipitation of the debris is such as to provide a distribution according to size, two quantitative measurements are made to provide information on size distribution, and thus the severity of wear mode within the system. The concentration of wear debris is determined by relating the total deposit of debris to the volume of oil which is mechanically regulated such that a combined time-and-temperature measurement enables the total volume to be computed. Since surface effect measurement of debris on the surface is nonlinear, system linearity is achieved by measuring the volume of lubricant required to precipitate a fixed quantity of debris. The On-Line Ferrograph is a cyclical device; once a complete measurement has been made, the system automatically recycles by flushing the sensing cell.

The unit undertakes a measurement over a period of time that automatically varies from 30 seconds to 30 minutes, depending on debris concentration and operating temperature. At the end of each cycle, three parameters are measured: large particles (LP), small particles (SP), and wear particle concentration (WPC). The units used for the large and small particles are arbitrary, the relevance of the information being the deviation from pre-established norms for that lubricating system. The three readings are remembered in individual registers and may be recalled and displayed individually. Each time a cycle is completed, the registers are updated with the most recent data. Figure 7 depicts the logic diagram of the On-Line Ferrograph.

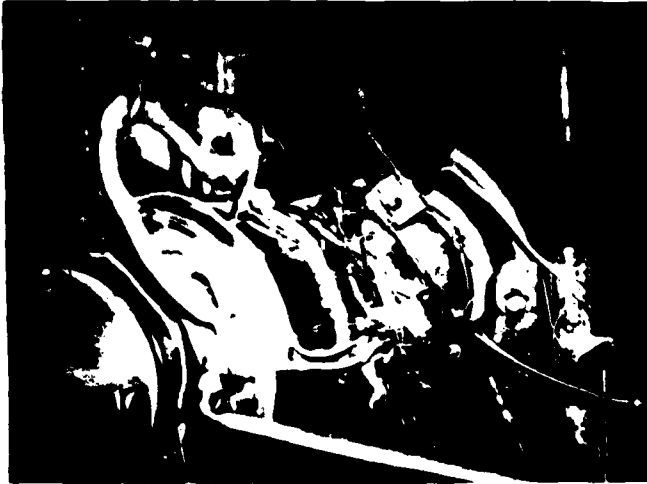

a. Sensor mounted on engine

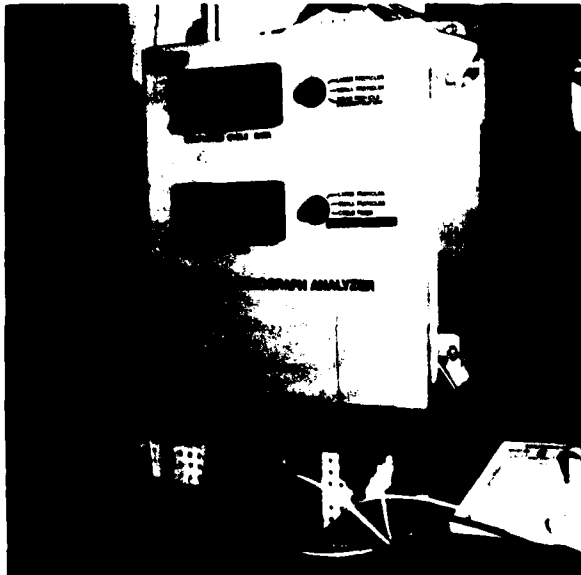

b. Analyzer

Figure 6. On-line unit and analyzer.

Corpus Christi Army Depot Participation

When the on-line unit was obtained, AMMRC, not having their own facilities, requested and received the cooperation of the Troop Support and Aviation Materiel Readiness Command (TSARCOM) to evaluate the unit on a helicopter engine in a test cell at CCAD. Without this cooperation by CCAD a proper evaluation of the on-line unit would not have been possible. To provide a means of verifying results of the on-line unit with those of the Analytical Ferrograph, AMMRC loaned their instrument to CCAD.

At CCAD a T53-L-13B helicopter engine was made available. However, before testing could begin several problems had to be overcome. The CCAD test cells had a lubrication supply system that was common to several test cells. Such a system was not suitable for this evaluation, therefore a test cell had to be modified to duplicate an actual aircraft lubrication system. A simulation of the UH-1H aircraft engine lubrication system was designed and fabricated by CCAD.

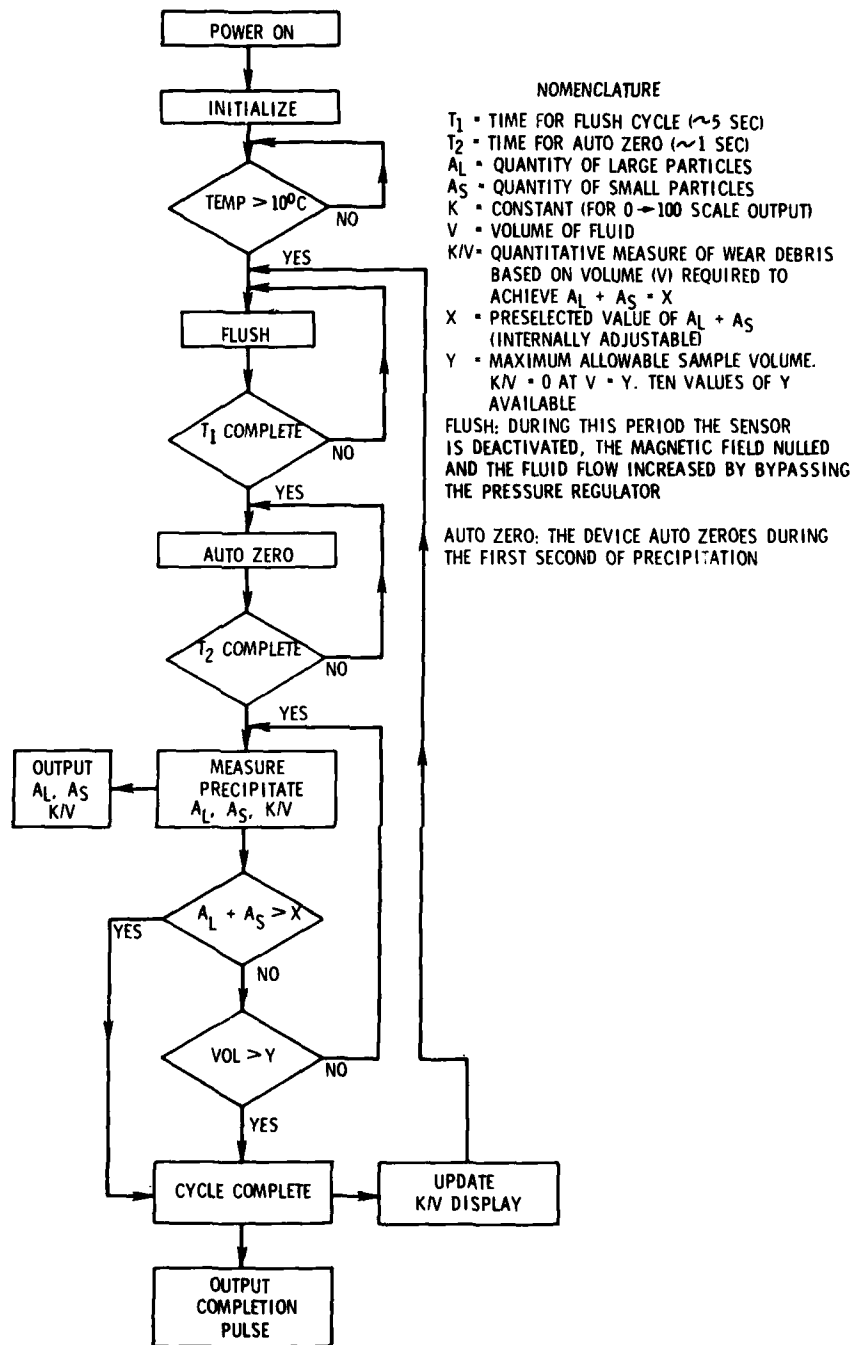

Figure 7. On-Line Ferrograph logic diagram.

Phase I

The first phase consisted of operating the test engine for 164 hours and 50 minutes. During this period the engine generated an extremely small quantity of wear metal. This allowed establishment of an On-Line Ferrograph data baseline for a "normal" engine. The LP readings were usually around a dimensionless reading of 0.05 or less although several times the readings exceeded 0.05 and in a few instances ranged as high as 0.10. An LP reading of 0.10 was established as baseline with readings above 0.10 indicating abnormal wear. The SP readings were usually around 0.01 and occasionally as high as 0.05. An SP reading of 0.05 was established as baseline; readings above 0.05 indicated abnormal wear. The WPC never went above the minimum reading of 1.0. Therefore 1.0 was established as the WPC baseline; anything above this indicated abnormal wear. Cycle time averaged approximately 30 minutes.

During the first phase of testing, a problem arose in which the initial signal from the analyzer at the beginning of a cycle was not "zeroing" the needle at the same place on the strip recorder. Because of the small amount of wear particles generated, the analyzer was operating at the extreme lower end of its sensitivity range. Upon completion of the first phase test, the analyzer was modified by the Foxboro Co. to improve "low end" sensitivity (this modification was one of the advancements made in later model Ferrograph Analyzers).

Since the analyzer provides digital readouts of both "in-process data" and "complete cycle data", the in-process LP and SP readings are constantly changing, identifying the quantity of debris as it is accumulated in the sensing head. When the sensing head becomes saturated, the cycle ends and the quantity of debris accumulated is compared to the volume of oil flow, a "debris per unit volume" value is calculated and identified as the WPC. The complete cycle LP, SP, and WPC values are updated at the end of each cycle. This is followed by a flush of the sensing head which "zeroes" the in-process data in preparation for the next cycle. In the case of very low wear particle generation in the oil system, a maximum oil flow will trigger the end of the cycle before the sensing head becomes saturated. In such cases the "in-process cycle timer" can be used to indicate the approaching end of the cycle due to maximum oil flow.

The sensing head never became saturated during the first testing phase; every cycle was terminated by reaching the maximum oil flow. Consequently, the WPC reading never rose above a minimum of 1.0.

The operating time it takes to achieve maximum oil flow will vary depending upon the temperature of the sensing head, which in turn depends upon the "oil-in" temperature, air temperature around the head, and heat conducted through a mounting bracket (which could be attached to a hot part of the operating machine). At the beginning of the first phase test, the sensing head was mounted just above the engine inlet housing (on engine mount ring) and even with warm July and August ambient temperatures the cycle time ranged approximately 30 minutes. In an attempt to shorten the cycle time, the sensing head was moved to the top of the oil cooler, but there was no significant change.

Phase II

Upon completion of the first phase of testing, the engine was partially disassembled to allow installation of "defective" bearings which were considered unfit for use and were expected to wear prematurely. The bearings were main ball bearings for positions 1 and 4, and a roller bearing for position 21.

After 165 hours into the second phase of testing, the LP and SP readings started to climb. Over a six-hour period the LP readings climbed from 0.05 to 0.37 and dwindled back to around 0.05; the SP readings climbed from 0.01 to 0.18 and dwindled back to 0.01. Even at peak LP and SP readings, the WPC never advanced beyond the 1.0 readings. Testing was stopped after 201 hours into the second phase. The defective bearings were not generating wear metals any faster than the original bearings. A position No. 4 main shaft ball bearing with more advanced degradation was selected and installed in the test engine. Testing was resumed and continued for 45 hours and 20 minutes.

During the last portion of the test considerable wear metals were generated. After 11.5 hours the WPC readings started increasing rapidly, peaking at 73.4 at approximately 14 hours. A problem arose with the analyzer due to the short cycle times that resulted from the increased WPC readings. Because of the short cycles (less than two minutes), the "flush" solenoid was not given ample opportunity to cool before being reactivated and, as a result, burned out. A design change was incorporated in later models to correct this. The analyzer was repaired and replaced in the system. Figure 8 depicts the results of this portion of the test.

During 401 hours of operation some lubricating oil had been added, but the oil had not been changed (see Figure 9). To determine the impact that an oil change would have, the lubrication system was flushed and clean filter elements were installed along with the fresh oil. The WPC rose above 1.0 after only 2 operating hours and during the next 5 operating hours the WPC readings ranged between 5.5 and 7.5. Suddenly the WPC reading jumped to 30.5 and during the final 3 hours of the test it stabilized around 14.5.

At this point it should be mentioned that SOAP samples were taken at least once a day during each test day and on some days were taken twice. During the last 10 hours of testing when the greatest wear was taking place, nine SOAP samples were taken. The SOAP values versus On-Line Ferrograph values are included in Figure 9.

In addition to SOAP samples, oil samples were taken for evaluation on the laboratory Ferrograph. It should be noted that the laboratory Ferrograph's small and large particle concentration readings do not correspond to the LP and SP readings from the On-Line Ferrograph. However, the On-Line Ferrograph's WPC readings, the laboratory Ferrograph's readings, and the iron content from the spectrometric analysis, all tend to increase and decrease together, but in varying degrees.

There was a considerable amount of fluctuation in the On-Line Ferrograph data. The data was affected significantly each time the engine was shut down, resulting in a series of fluctuating data curves. The laboratory Ferrograph data, taken from periodic oil samples, relates to data taken at random points from a series of fluctuating curves.

The wear particles in the Ferrogram ranged in size from 3 to 10 microns. This is the particle size associated with normal rubbing wear; however, these particles were being produced in massive quantities by the defective bearing. Particles in this size range are ideal for spectrographic identification. A moderate amount of dark metal-oxide "chips" were also present in the Ferrogram. These particles were produced by the spalling of hard steels such as are found in rolling elements. The test did not advance to the point where more of the larger type particles (metal spirals, chunks, or spheres) associated with advanced wear conditions would be generated. Difficulty is encountered in identifying the existence of these larger particles with the spectrograph. The On-Line Ferrograph may be more effective than the spectrograph in identifying their existence.

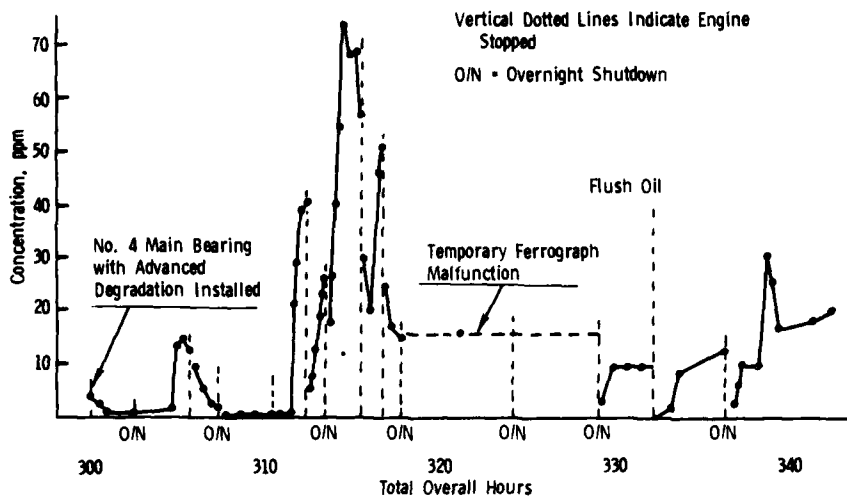

Figure 8. Data obtained with On-Line Ferrograph.

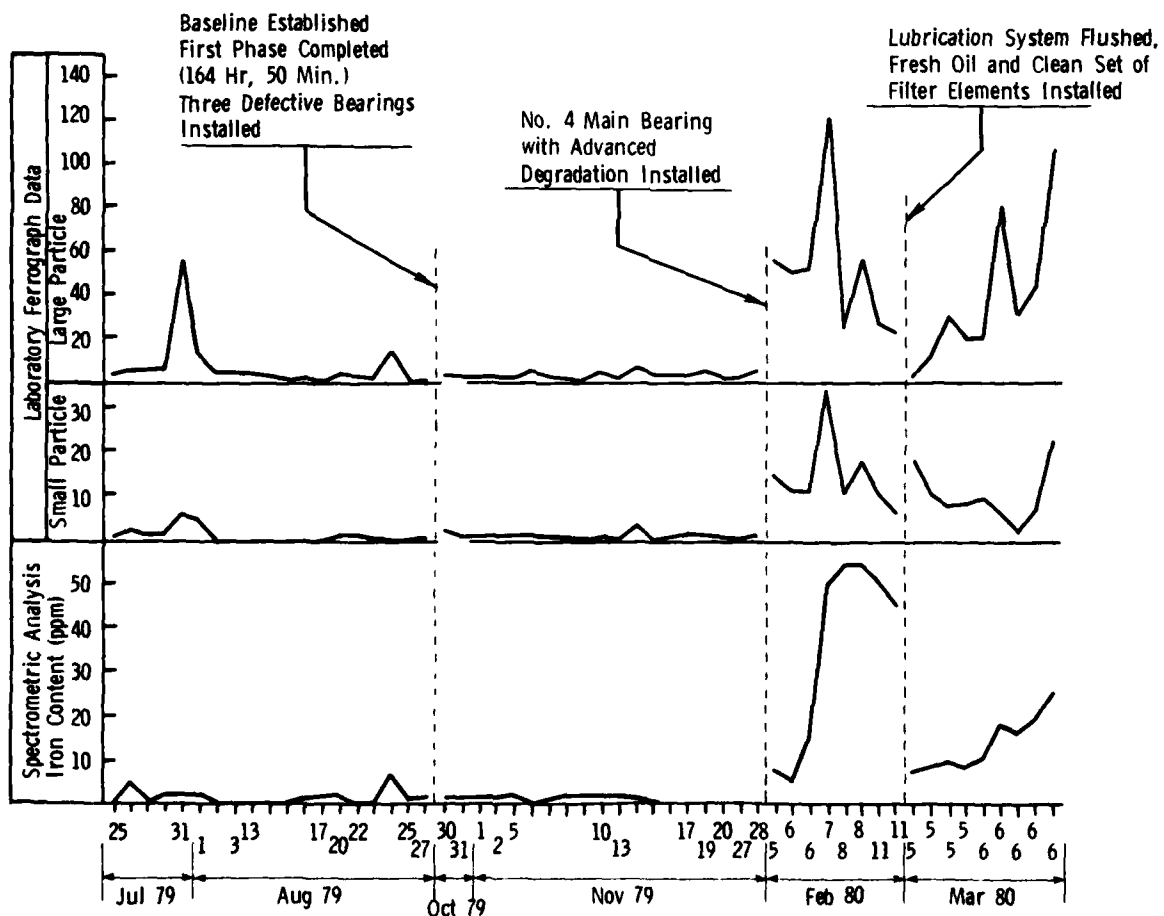

Figure 9. SOAP and laboratory Ferrograph data comparison.

CONCLUSIONS

Experiments with the Analytical Ferrograph showed the instrument to be an accurate indicator of the degree of wear of an oil-wetted system such as an engine or a transmission. However, the training required for preparing a Ferrogram and for interpretation is lengthy. The interpretation is particularly difficult and requires considerable training and experience before accuracy can be achieved. Preparation of the Ferrogram is time-consuming, requiring approximately 30 minutes to prepare and considerable hand manipulation. Kits for each Ferrogram cost approximately \$7.50. On the other hand, SOAP analysis takes a minute or so on automated equipment at a cost of slightly more than a dollar for a complete readout, exclusive of administrative costs. The Army in FY80 took approximately 350,000 SOAP readings. When one compares the labor and materials cost of SOAP versus the cost of Ferrography, it is easy to see that the monetary increase does not substantiate the gain in the quality of the readout. Moreover, the SOAP program is established and personnel in the field have been trained. Training of personnel is a major problem when new programs are implemented within the Armed Forces. Service-wide training of personnel would be a very expensive and time-consuming process.

Ferrography is an excellent complement to the SOAP program. It is not uncommon for a questionable SOAP evaluation to be verified by Ferrography, thereby preventing a possible needless overhaul or, conversely, recommending an overhaul if such was necessary. There have also been instances where Ferrography has detected an imminent failure that was missed by SOAP. To the best of our knowledge, no studies have been made or instances recorded where Ferrography missed a potential failure that was detected by SOAP. Thousands of SOAP samples are analyzed daily on automated equipment in the Armed Forces, whereas in the same time span only a few hand-processed Ferrograms are produced. No known attempts are being made by the instrument's manufacturer to automate or semi-automate the Analytical Ferrograph.

Therefore it can be concluded that the Analytical Ferrograph is a valuable complement to the Army's oil analysis program but cannot supplant the present SOAP program.

The On-Line Ferrograph was installed in the oil line of a helicopter engine to provide a near real-time indication of wear in that component. The Army ran only one test of the on-line unit because of the time and expense involved. The results, as frequently happens in a complex test of this sort, were a mixture of varying degrees of success and failure. The on-line unit provided the warning of impending failure as did the standard SOAP readings. The 46 operating hours on the defective No. 4 bearing represent about four to five weeks of aircraft operation, during which time SOAP samples would have been analyzed every 10 operating hours and the failure detected. Spectrometric analysis is the backbone of the Army oil analysis program and when a wear rate becomes abnormally high, a complementary Ferrogram analysis provides a more complete picture by identifying the type of wear. To supplant the present system, the on-line unit would have to be more responsive, or provide data that is more accurate and reliable, easier to evaluate and more indicative of a failure mode. It should also be more cost-effective in providing needed data that is not presently available.

On the positive side, the use of an On-Line Ferrograph could reduce the number of oil samples being processed by SOAP. The requirement for laboratory analysis of an oil sample every 10 operating hours could possibly be eliminated in favor of "on-condition" oil sampling which could be triggered by an on-line unit. However, such a system would require several sensing heads to monitor engines, transmissions, and hydraulic systems, and would be adding undesired weight to an aircraft.

The On-Line Ferrograph was a first-generation model and improvements have since been made. To carry through development of the unit to a flight-certified flying model would be very expensive and it is uncertain whether the end result would justify the expense. For example, testing of the On-Line Ferrograph would have to continue until it is determined that the unit functions successfully under the complete spectrum of wear conditions that occur in helicopter engines, transmissions, and hydraulic systems. Each test is lengthy and expensive in fuel and manpower use. A determination of long-term reliability under rugged field conditions would also have to be made. Experience has shown that any new system introduced into the field meets resistance from both the mechanics who have to monitor, repair, and replace the units, and the pilots who have to fly with them. Each claims they have enough to do and any added responsibilities are generally unwelcome.

The wisdom of further evaluation of the On-Line Ferrograph is complicated by a recent trend in the Army toward fine filtration lubricating systems of the order of 3 microns. Such filtration leaves too little debris in the lubricant for meaningful evaluation by either SOAP or Ferrography.

In the final analysis it can be concluded that the Analytical Ferrograph is a valuable complementary laboratory tool to the SOAP program, and should be continued as long as the SOAP program is active. The On-Line Ferrograph, on the other hand, requires a lengthy and expensive development and evaluation program whose long-term benefits over the present system are uncertain. Fine filtration systems presently under evaluation, if implemented throughout the Army, could substantially reduce or eliminate the SOAP program for aircraft as it now stands. Therefore, faced with such uncertainties, the effect of the fine filtration systems should be evaluated before final decisions are made on the relative merits of the spectrometric oil analysis program versus Ferrography.

DISTRIBUTION LIST

No. of Copies	To
	Metals and Ceramics Information Center, Battelle Columbus Laboratories, 505 King Avenue, Columbus, OH 43201
1	ATTN: Mr Harold Mindlin, Director
1	Mr. James Lynch, Assistant Director
12	Commander, Defense Technical Information, Center, Cameron Station, Building 5, 5010 Duke Street, Alexandria, VA 22314
	Commander, U.S. Army Research Science and Technology Center, 220 Seventh St., N.E., Charlottesville, VA 22901
1	ATTN: DRXST-SD3
	Office of the Deputy Chief of Staff for Research, Development, and Acquisition, Washington, DC 20310
1	ATTN: DAMA-ARZ-E
1	DAMA-CSS
	Commander, Army Research Office, P.O. Box 12211, Research Triangle Park, NC 27709
1	ATTN: Dr. George Mayer
1	Mr. J. J. Murray
	Commander, U.S. Army Materiel Development and Readiness Command, 5001 Eisenhower Avenue, Alexandria, VA 22333
1	ATTN: DRCQA-E
1	DRCQA-P
1	DRCDE-D
1	DRCDMD-FT
1	DRCLDC
1	DRCMT
1	DRCMM-M
	Commander, U.S. Army Electronics Research and Development Command, Fort Monmouth, NJ 07703
1	ATTN: DELSD-PA-E, Mr. Stan Alster
1	DELS-PA-E, Mr. J. Quinn
	Commander, U.S. Army Missile Command, Redstone Arsenal, AL 35809
2	ATTN: DRSMI-TB, Redstone Scientific Information Center
1	DRSMI-TK, Mr. J. Alley
1	DRSMI-M
1	DRSMI-ET, Mr. Robert O. Black
1	DRSMI-QS, Mr. George L. Stewart, Jr.
1	DRSMI-EAT, Mr. R Talley
1	DRSMI-QP
1	DRSMI-RLM
	Commander, U.S. Army Materiel Systems Analysis Activity, Aberdeen Proving Ground, MD 21005
1	ATTN: DRXSY-MP, H. Cohen

No. of
Copies

To

Director, U.S. Army Ballistic Research Laboratory,
Aberdeen Proving Ground, MD 21005
1 ATTN: DRDAR-TSB-S (STINFO)

Commander, U.S. Army Troop Support and Aviation Materiel Readiness Command,
4300 Goodfellow Boulevard, St. Louis, MO 63120
1 ATTN: DRSTS-PL(2), Mr. J. Corwin
1 DRSTS-Q
1 DRSTS-M

Commander, U.S. Army Natick Research and Development Laboratories,
Natick, MA 01760
1 ATTN: DRDNA-EM

Commander, U.S. Army Mobility Equipment Research and Development Command,
Fort Belvoir, VA 22060
1 ATTN: DRDME-D
1 DRDME-E
1 DRDME-G
1 DRDME-H
1 DRDME-M
1 DRDME-T
1 DRDNE-TQ
1 DRDME-V
1 DRDME-ZE
1 DRDME-N

Commander, U.S. Army Tank-Automotive Materiel Readiness Command, Warren, MI 48090
2 ATTN: DRSTA-Q

Commander, U.S. Army Armament Materiel Readiness Command, Rock Island, IL 61299
2 ATTN: DRSAR-QA
1 DRSAR-SC
1 DRSAR-RDP
1 DRSAR-EN
1 DRSAR-QAE

Commander, Rock Island Arsenal, Rock Island, IL 61299
1 ATTN: SARRI-EN, Mr. W. M. Kisner
1 SARRI-ENM, W. D. McHenry
1 SARRI-QA

Commander, U S Army Armament Research and Development Command, Dover, NJ 07801
1 ATTN: DRDAR-LC, Mr. E. Kelly
1 DRDAR-LCA, Dr. Sharkoff
1 DRDAR-LCE, Dr. Walker
5 DRDAR-QAS, Mr. F. Fitzsimmons
1 DRDAR-SCM, Mr. J. D. Corrie
1 DRDAR-TSP, Mr. B. Stephans
2 DRDAR-TSS (STINFO)
1 DRDAR-LCA, Mr. Harry E. Pebly, Jr , PLASTECH, Director

No. of
Copies

To

1 Commander, Chemical Systems Laboratory, Aberdeen Proving Ground, MD 21010
ATTN: DRDAR-CLD, Mr. W. E. Montanary

1 Commander, ARRADCOM, Product Assurance Directorate, Aberdeen Proving
Ground, MD 21010
ATTN: DRDAR-QAC-E, Dr. W. J. Maurits

1 Commander, Watervliet Arsenal, Watervliet, NY 12189
ATTN: DRDAR-LCB, Mr. T. Moraczewski
2 SARWV-PPI, Mr. L. Jette

1 Commander, U.S. Army Aviation Research and Development Command,
St. Louis, MO 63120
ATTN: DRDAV-EGX
1 DRDAV-QR
1 DRDAV-QP
1 DRDAV-QE

1 Commander, U.S. Army Tank-Automotive Research and Development Command,
Warren, MI 48090
ATTN: DRDTA-UL, Technical Library
1 DRDTA-RCKM, Mr. S. Goodman
1 DRDTA-RCKT, Mr. J. Fix
1 DRDTA-RTAS, Mr. S. Catalano
1 DRDTA-TTM, Mr. W. Moncrief
1 DRDTA-ZS, Mr. O. Renius
1 DRDTA-JA, Mr. C. Kedzior

1 Director, U.S. Army Industrial Base Engineering Activity, Rock Island, IL 61299
ATTN: DRXIB-MT, Mr. D. Brim

1 Commander, Harry Diamond Laboratories, 2800 Powder Mill Road, Adelphi, MD 20783
ATTN: DELHD-EDE, Mr. B. F. Willis

1 Commander, U.S. Army Test and Evaluation Command, Aberdeen Proving Ground,
MD 21005
ATTN: DRSTE-TD
1 DRSTE-ME

1 Commander, U.S. Army White Sands Missile Range, NM 88002
ATTN: STEWS-AD-L
1 STEWS-ID
1 STEWS-TD-PM

1 Commander, U.S. Army Yuma Proving Ground, Yuma, AZ 85364
ATTN: Technical Library

1 Commander, U.S. Army Tropic Test Center, Fort Clayton, Canal Zone
ATTN: STETC-TD, Drawer 942

1 Commander, Aberdeen Proving Ground, MD 21005
ATTN: STEAP-MT
1 STEAP-MT-M, Mr. J. A. Feroli
1 STEAP-MT-G, Mr. R. L. Huddleston

No. of
Copies

To

1	Commander, U.S. Army Cold Region Test Center, APO Seattle, WA 98733 ATTN: STECR-OP-PM
1	Commander, U.S. Army Dugway Proving Ground, Dugway, UT 84022 ATTN: STEDP-MT
1	Commander, U.S. Army Electronic Proving Ground, Fort Huachuca, AZ 85613 ATTN: STEEP-MT
1	Commander, Jefferson Proving Ground, Madison, IN 47250 ATTN: STEJP-TD-I
1	Commander, U.S. Army Aircraft Development Test Activity, Fort Rucker, AL 36362 ATTN: STEBG-TD
1	President, U.S. Army Armor and Engineer Board, Fort Knox, KY 40121 ATTN: ATZKOE-TA
1	President, U.S. Army Field Artillery Board, Fort Sill, OK 73503 ATTN: ATZR-BDOP
1	Commander, Anniston Army Depot, Anniston, AL 36202 ATTN: SDSAN-QA
1	Commander, Corpus Christi Army Depot, Corpus Christi, TX 78419 ATTN: SDSCC-MEE, Mr. Haggerty, Mail Stop 55
1	Commander, Letterkenny Army Depot, Chambersburg, PA 17201 ATTN: SDSLE-QA
1	Commander, Lexington-Bluegrass Army Depot, Lexington, KY 40507 ATTN: SDSLX-QA
1	Commander, New Cumberland Army Depot, New Cumberland, PA 17070 ATTN: SDSNC-QA
2	Commander, U.S. Army Depot Activity, Pueblo, CO 81001 ATTN: SDSTE-PU-Q
1	Commander, Red River Army Depot, Texarkana, TX 75501 ATTN: SDSRR-QA
1	Commander, Sacramento Army Depot, Sacramento, CA 95813 ATTN: SDSSA-QA
1	Commander, Savanna Army Depot Activity, Savanna, IL 61074 ATTN: SDSSV-S
1	Commander, Seneca Army Depot, Romulus, NY 14541 ATTN: SDSSE-R

No. of
Copies

To

1	Commander, Sharpe Army Depot, Lathrop, CA 95330 ATTN: SDSSH-QE
1	Commander, Sierra Army Depot, Herlong, CA 96113 ATTN: SDSSI-DQA
1	Commander, Tobyhanna Army Depot, Tobyhanna, PA 18466 ATTN: SDSTO-Q
1	Commander, Tooele Army Depot, Tooele, UT 84074 ATTN: SDSTE-QA
1	Director, DARCOM Ammunition Center, Savanna, IL 61074 ATTN: SARAC-DE
1	Naval Research Laboratory, Washington, DC 20375 ATTN: Dr. J. M. Krafft, Code 5830
1	Library, Code 2620
1	Commander, U.S. Air Force Wright Aeronautical Laboratories, Wright Patterson Air Force Base, OH 45433 ATTN: AFWAL/MLTM, Mr. W. Wheeler
1	AFWAL/MLLP, Mr. R. Rowand
1	Mr R. J. Zentner, EAI Corporation, 198 Thomas Johnson Drive, Suite 16, Frederick, MD 21701
2	Director, Army Materials and Mechanics Research Center, Watertown, MA 02172 ATTN: DRXMR-PL
1	DRXMR-D
1	DRXMR-FI
2	DRXMR-ST
1	DRXMR-STQ
1	DRXMR-STN
1	DRXMR-SS
1	DRXMR-S
1	DRXMR-M
1	DRXMR-OM, Mr. Valente
1	DRXMR-AT
3	Authors

AD
UNCLASSIFIED
UNLIMITED DISTRIBUTION
Key Words

AD
UNCLASSIFIED
UNLIMITED DISTRIBUTION
Key Words

Army Materials and Mechanics Research Center,
Watertown, Massachusetts 02172
MECHANICAL WEAR ASSESSMENT OF HELICOPTER
ENGINES BY FERROGRAPHY -
Charles P. Merhib, Samuel J. Acquaviva,
and Robert W. Ladner
Technical Report AMMRC TR 81-55, November 1981, 17 pp -
illus-table, D/A Project M796350,
AMCMS Code 539/0M6350

Army Materials and Mechanics Research Center,
Watertown, Massachusetts 02172
MECHANICAL WEAR ASSESSMENT OF HELICOPTER
ENGINES BY FERROGRAPHY -
Charles P. Merhib, Samuel J. Acquaviva,
and Robert W. Ladner
Technical Report AMMRC TR 81-55, November 1981, 17 pp -
illus-table, D/A Project M796350,
AMCMS Code 539/0M6350

Two Ferrograph analyzers, an analytical or laboratory Ferrograph® and an On-Line (quasi-real-time) Ferrograph, were evaluated. The analytical Ferrograph was found to be an effective supplement to the spectrometric oil analysis program (SOAP) since the Ferrograph analyzes particles in the range of 1 to over 100 microns while SOAP analyzes particles below 5 microns in size. Comments are also offered on a third analyzer, the Direct Reading (DR) Ferrograph. To evaluate the analytical Ferrograph, oil samples from helicopters at Fort Devens, Massachusetts, were analyzed. One transmission was found with excessive wear particles which was later verified by SOAP. The On-Line Ferrograph was tested in 410 hours of operation using a T53-L-138 helicopter engine in a test cell at the Corpus Christi Army Depot. After determining baseline data for the engine, defective bearings were substituted to enhance particle wear penetration. The particles subsequently generated were successfully detected by both the On-Line Ferrograph and SOAP.

Two Ferrograph analyzers, an analytical or laboratory Ferrograph® and an On-Line (quasi-real-time) Ferrograph, were evaluated. The analytical Ferrograph was found to be an effective supplement to the spectrometric oil analysis program (SOAP) since the Ferrograph analyzes particles in the range of 1 to over 100 microns while SOAP analyzes particles below 5 microns in size. Comments are also offered on a third analyzer, the Direct Reading (DR) Ferrograph. To evaluate the analytical Ferrograph, oil samples from helicopters at Fort Devens, Massachusetts, were analyzed. One transmission was found with excessive wear particles which was later verified by SOAP. The On-Line Ferrograph was tested in 410 hours of operation using a T53-L-138 helicopter engine in a test cell at the Corpus Christi Army Depot. After determining baseline data for the engine, defective bearings were substituted to enhance particle wear penetration. The particles subsequently generated were successfully detected by both the On-Line Ferrograph and SOAP.

AD
UNCLASSIFIED
UNLIMITED DISTRIBUTION
Key Words

AD
UNCLASSIFIED
UNLIMITED DISTRIBUTION
Key Words

Army Materials and Mechanics Research Center,
Watertown, Massachusetts 02172
MECHANICAL WEAR ASSESSMENT OF HELICOPTER
ENGINES BY FERROGRAPHY -
Charles P. Merhib, Samuel J. Acquaviva,
and Robert W. Ladner
Technical Report AMMRC TR 81-55, November 1981, 17 pp -
illus-table, D/A Project M796350,
AMCMS Code 539/0M6350

Army Materials and Mechanics Research Center,
Watertown, Massachusetts 02172
MECHANICAL WEAR ASSESSMENT OF HELICOPTER
ENGINES BY FERROGRAPHY -
Charles P. Merhib, Samuel J. Acquaviva,
and Robert W. Ladner
Technical Report AMMRC TR 81-55, November 1981, 17 pp -
illus-table, D/A Project M796350,
AMCMS Code 539/0M6350

Two Ferrograph analyzers, an analytical or laboratory Ferrograph® and an On-Line (quasi-real-time) Ferrograph, were evaluated. The analytical Ferrograph was found to be an effective supplement to the spectrometric oil analysis program (SOAP) since the Ferrograph analyzes particles in the range of 1 to over 100 microns while SOAP analyzes particles below 5 microns in size. Comments are also offered on a third analyzer, the Direct Reading (DR) Ferrograph. To evaluate the analytical Ferrograph, oil samples from helicopters at Fort Devens, Massachusetts, were analyzed. One transmission was found with excessive wear particles which was later verified by SOAP. The On-Line Ferrograph was tested in 410 hours of operation using a T53-L-138 helicopter engine in a test cell at the Corpus Christi Army Depot. After determining baseline data for the engine, defective bearings were substituted to enhance particle wear penetration. The particles subsequently generated were successfully detected by both the On-Line Ferrograph and SOAP.

Two Ferrograph analyzers, an analytical or laboratory Ferrograph® and an On-Line (quasi-real-time) Ferrograph, were evaluated. The analytical Ferrograph was found to be an effective supplement to the spectrometric oil analysis program (SOAP) since the Ferrograph analyzes particles in the range of 1 to over 100 microns while SOAP analyzes particles below 5 microns in size. Comments are also offered on a third analyzer, the Direct Reading (DR) Ferrograph. To evaluate the analytical Ferrograph, oil samples from helicopters at Fort Devens, Massachusetts, were analyzed. One transmission was found with excessive wear particles which was later verified by SOAP. The On-Line Ferrograph was tested in 410 hours of operation using a T53-L-138 helicopter engine in a test cell at the Corpus Christi Army Depot. After determining baseline data for the engine, defective bearings were substituted to enhance particle wear penetration. The particles subsequently generated were successfully detected by both the On-Line Ferrograph and SOAP.

**DAI
FILM**