

AD A111162

LEVEL II

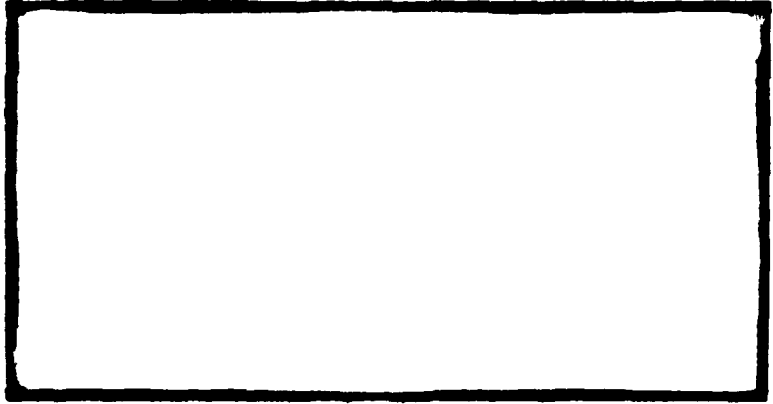

DTIC
ELECTE
FEB 18 1982
S D
E



DTIC FILE COPY

DEPARTMENT OF THE AIR FORCE
AIR UNIVERSITY (ATC)
AIR FORCE INSTITUTE OF TECHNOLOGY

Wright-Patterson Air Force Base, Ohio

This document has been approved
for public release and sale; its
distribution is unlimited.

82 02 18 062

AFIT/GAE/AA/81D-16

DESIGN, FABRICATION AND TESTING
OF AN
AXISYMMETRIC, ANNULAR, SUBSONIC
DIFFUSER
AND
ASSOCIATED INSTRUMENTATION SYSTEMS

THESIS

AFIT/GAE/AA/81D-16

John V. Kelley, Jr.
2nd Lt USAF

Approved for public release; distribution unlimited.

Preface

The annular diffuser research project was sponsored by the Aero Propulsion Laboratory, AFWAL/POTC, with Mr. Dale Hudson, the Laboratory coordinator. The research was an integral part of a six-year program to advance aerodynamic modeling for gas turbine combustion systems. The combustion system includes the diffuser and the combustor area. The investigation objective is to provide vital experimental data to aid in the design of annular diffusers typical of the combustor inlet diffusing section. Optimum design of the diffuser flow field is of utmost importance because total pressure losses occurring in the diffuser contribute directly to poor overall performance and reduced overall engine fuel efficiency. The data collected in the form of detailed aerodynamic parameters will be used to validate and expand the state of the art of advanced, analytical, three-dimensional, viscous flow models. The volume of specific data needed by these models to define boundary conditions and verify predicted phenomena far exceeds the details required in previous experimental practice. The development of a gas turbine combustion system (including its annular diffuser) requires five years of concentrated effort utilizing current computational capability. Advanced modeling, developed from and validated by extensive detailed aerodynamic data, has proven the potential of reducing these costs in time by two thirds.

This full potential can only be achieved if a new

generation of diffuser aerodynamic data can be created to support continued economical model development. The present annular diffuser investigation constitutes a beginning and will provide the specific data required by the program to advance gas turbine combustion system modeling.

Thanks are due to Dr. Harold Wright, my advisor, for his encouragement, understanding, guidance, and support. Dr. William Elrod and Dr. Milton Franke provided valuable suggestions as thesis committee members. Mr Dale Hudson, as the sponsor of this project provided financial aid and technical knowledge indispensable for completing this study. The extremely difficult task of fabricating an annular diffuser of a novel, very complex design was ably accomplished by Mr Frank Noll, a craftsman with the 4950th Test Wing Fabrication and Modification Shop. My sincere appreciation goes to Mr Carl Short, Mr John Brohas, Mr J. G. Tiffany, and Mr Ron Ruley of the AFIT Model Fabrication Division whom I continually plagued with sketchy drawings and ideas and who always came through with a finished product better than the original description. The Air Force Institute of Technology must also be recognized for providing laboratory facilities to carry out this work. Thanks are also due to Mr Gregg Tibbs who sacrificed his spare time for assisting in the design of the needed computer interface, and to Mr Leroy Cannon who constructed the interface and, with Mr Bill Baker, offered technician assistance in other areas. Last, but not least, my fiancée,

Miss Janet Arildsen, deserves my deepest gratitude for her love, support, and understanding throughout these challenging 18 months.

John V. Kelley, Jr.

Contents

Preface ii

List of Figures vi

List of Tables. viii

List of Symbols ix

Abstract xi

I. Introduction 1

II. Theory and Development of Diffusers 4

III. Design of Experimental Apparatus 10

IV. Instrumentation 18

V. Integrated Systems and Experimental Techniques 27

VI. Results and Discussion - System Evaluation 33

VII. Conclusions 39

VIII. Recommendations 40

Bibliography 41

Appendix A: Figures 45

Appendix B: Tables 68

Appendix C: Hot Film Turbulent Velocity Calculations 77

Vita 78

List of Figures

| <u>Figure</u> | | <u>Page</u> |
|---------------|--|-------------|
| 1 | Well Behaved Flow in a Diffuser | 46 |
| 2 | Unsteady Zones of Stall in a Diffuser | 46 |
| 3 | Steady Stall in a Diffuser | 46 |
| 4 | Jet Flow in a Diffuser | 46 |
| 5 | Two-Dimensional Straight Wall Diffuser Dimensions | 47 |
| 6 | Annular Diffuser Dimensions | 47 |
| 7 | Cross Sectional View of the Annular Diffuser Model and Instrumented Points | 48 |
| 8 | Inlet End View of the Annular Diffuser Model and Instrumented Stations | 49 |
| 9 | Exit End View of the Annular Diffuser Model | 50 |
| 10 | Diffuser Inlet Cone | 51 |
| 11 | Diffuser Insert | 52 |
| 12 | Pitot Tube | 53 |
| 13 | Pressure Transducer and Electronics | 54 |
| 14 | Hot Film Sensor and Electronics | 55 |
| 15 | Hot Film Sensor Calibration Curve | 56 |
| 16 | Laser, Optics and Platform | 57 |
| 17 | Control Volume for Laser. | 58 |
| 18 | Traversing Mechanism | 59 |
| 19 | Holder, Laser Window and Slot | 60 |
| 20 | LDV System Electronics | 60 |
| 21 | Radial Pressure Profiles for the Pitot Tube with Pressure Transducers | 61 |
| 22 | Radial Pressure Profiles for the Pitot Tube with Water Manometer | 62 |

| | <u>Page</u> |
|----|---|
| 23 | Radial Velocity Profiles for the Pitot Tube with Pressure Transducers 63 |
| 24 | Radial Velocity Profiles for the Pitot Tube with Water Manometer 64 |
| 25 | Radial Velocity Profiles for the Hot Film Sensor 65 |
| 26 | Pressure Transducer Calibration Curve - S.N. L160401 66 |
| 27 | Pressure Transducer Calibration Curve - S.N. L160407 66 |
| 28 | Hot Film Sensor and Pitot Tube Velocity Data . 67 |

List of Tables

| <u>Table</u> | <u>Page</u> |
|--|-------------|
| I. Geometrical Relationships for Flat, Conical and Annular Diffusers | 69 |
| II. Annular Diffuser Inlet Conditions | 69 |
| III. Diffusing Section Exit Velocities | 70 |
| IV. Diffuser Dump Flow Velocities | 70 |
| V. Pitot Tube with Pressure Transducers - Data . . . | 71 |
| VI. Pitot Tube with Water Manometer - Data | 72 |
| VII. Hot Film Sensor Data | 73 |
| VIII. Data Comparison at the Same Flow Conditions . . . | 74 |
| IX. Pressure Transducer Calibration Data S.N, L160401 | 75 |
| X. Pressure Transducer Calibration Data - S.N. L160407 | 76 |

Symbols

| | | |
|-----------------|-------------------------------|----------------------|
| A | area | ft ² |
| o A | angstroms | 10 ⁻¹⁰ m |
| AR | area ratio | |
| a | speed of sound in air | ft/sec |
| BEF | beam expansion factor | |
| BS | beam spacing | mm |
| C _p | pressure coefficient | |
| C _{PR} | pressure recovery coefficient | |
| df | fringe spacing | μm |
| dm | LDV control volume height | μm |
| FL | focal length | mm |
| FS | fringe spacing | μm |
| f _d | doppler frequency | Hz |
| HP | Hewlett Packard | |
| h | channel height | in |
| IGV's | inlet guide vanes | |
| k | ratio of specific heats | |
| L | length | in |
| LDV | laser doppler velocimeter | |
| lm | LDV control volume length | mm |
| M | Mach number | |
| m | mass flow rate | lb _m /sec |
| Pa | ambient pressure | psi |

| | | |
|-----------|---------------------------------------|--|
| P_s | static pressure | psi |
| P_t | total pressure | psi |
| R | gas constant for air | $\frac{\text{ft lb}}{^{\circ}\text{R lb}_m}$ |
| Re | Reynold's number | |
| RMS | root mean square | |
| T_a | ambient temperature | $^{\circ}\text{R}$ |
| T_s | static temperature | $^{\circ}\text{R}$ |
| T_t | total temperature | $^{\circ}\text{R}$ |
| V | velocity | ft/sec |
| X | distance along flat plate | in |
| δ | boundary layer height | in |
| η | diffuser efficiency | |
| κ | half angle of laser beam intersection | degrees |
| λ | wavelength | \AA |
| ρ | density | lbm/ft^3 |

Abstract

Aerodynamic parametric data of annular diffuser flow fields for gas turbine engines are not available in sufficient detail. They are badly needed for future high efficiency engine design.

A subsonic, axisymmetric, annular diffuser model was designed for the purpose of making such highly detailed information available. The objective of the design was to approximate an actual gas turbine engine diffuser. The diffuser was built according to these design specifications.

The instrumentation required to gather the necessary pressure, velocity, and turbulence parameters consisted of three pitot tube systems, a hot wire anemometer system and a laser doppler velocimeter (LDV) system using frequency counting. These three instrumentation systems were integrated into the diffuser to obtain data at each of three points along the longitudinal axis. At each point there were five stations around the annulus that were instrumented. A longitudinal traversing structure utilizing motorized traversers for radial positioning and the capability to integrate absolute encoders was used to access the flow area.

The three instrumentation systems have the capability to be integrated into a Hewlett Packard 9845/B

computer-controller for data acquisition and processing. The experimental apparatus, data acquisition and processing, and flow traversing were integrated and functional, as demonstrated by the preliminary data.

I Introduction

The flow for the case of an adverse pressure gradient, i.e., flow through a diffuser, has been of major interest to aerodynamic researchers for a considerable time. The diffuser is a very old but extremely useful device. It provides a means of reducing the velocity of a fluid stream while increasing its static pressure. The diffuser has resisted analysis even of the most modern nature. It has a very simple geometry and yet a large number of fundamental questions remain unsolved. Maximizing pressure recovery or efficiencies, defining confined swirling flows, swirl induced effects and multiple scale turbulence are just a few. Therefore, researchers must mainly rely on experimental methods to achieve some understanding of diffuser behavior and optimizing procedures.

Some of the earliest research in the field of flow with an adverse pressure gradient was done by Gibson and Eiffel (Ref 37) during the early part of the twentieth century. Since then, much work has been done on plane and conical diffusers. Kline was a leading researcher and many design groups still use his data (1959) in designing modern day diffusers. In more recent times, researchers had concentrated their investigations on plane and conical diffusers. Three-dimensional annular diffusers are only now receiving the

attention that is required. The relatively sparse amount of research work heretofore carried out on annular diffusers was compiled mainly by Cockrell (Ref 7) and Sovran and Klomp (Ref 8).

Interest in annular diffusers has greatly increased in recent years because of their application to turbomachinery. "There is considerable need in model development and design for reliable test data on the efficiency, stalling, and instability characteristics of annular diffusers" (Ref 20). Most investigations have been conducted under conditions where the inlet flow is fully developed and free from swirl. However, in many applications, the inlet flow to an annular diffuser is accompanied by swirling motion; such is the flow of interest in this investigation. The effect of swirl on annular diffusers has been primarily researched by Schwartz (Ref 9) and Srinath (Ref 10).

The objectives of this investigation are threefold. First, an annular diffuser is to be designed and built to model the annular diffuser arranged between the compressor exit and the combustor inlet in a gas turbine engine. The flow through the annular diffuser is to be subsonic and exhausting to ambient pressure and temperature. The annular diffuser model is to be equipped with a set of inlet guide vanes (IGV's) to produce up to ten deg of swirl and a removable

center section to change the area ratio of the diffusing section. The preliminary testing schedule calls for a 120 deg section in order to conserve the mass rate of air flow available at the AFIT laboratories. An inlet cone and accompanying inserts are to be constructed to provide air flow to the 120 deg section. This will enable data acquisition at up to two stations around the annulus simultaneously and a maximum inlet Mach number of 0.14.

Second, instrumentation is to be selected and integrated into the diffuser design in order to provide reliable and reproducible data for determining pressures, velocities and turbulence intensities at positions of interest along the axis and the periphery of the diffuser.

The third objective is to provide the capability for semiautomatic data acquisition and processing using a HP 9845/B computer-controller data acquisition system. A motorized traversing system that allows data acquisition at five stations around the annulus either simultaneously or individually is to be integrated into the system. Preliminary data shall be taken to validate the system and provide a baseline as well as ensure its support of both AFIT and the Aero Propulsion Laboratory.

Thus, the objectives of the investigation are outlined. The next topic considers diffuser development and preliminary testing.

II Theory and Development of Diffusers

A review of diffuser behavior was published by G. N. Patterson (Ref 31) in 1938. The review was the accepted guide to diffuser design until the early 1960's. Since then, there has been an improved analytical understanding of diffusers. The importance of efficiency criteria for conical and straight wall diffusers has been recognized. Research and development has turned increasingly in the direction of the annular diffuser during the last two decades. The annular diffuser is an important component in gas turbine combustion systems. The goal is to design an optimum system which considers efficiency, economy, and compactness of annular diffusers.

The adverse pressure gradient flow experienced in diffusers is irreversible because of wall friction. This flow may be accompanied by boundary layer separation or stall. Stall in a diffuser is backward motion of some part of the fluid stream. When this occurs, diffuser performance usually suffers seriously as observed by the loss of total pressure.

There are basically four types of flow in diffusers, determined by the rate at which the flow area increases. The boundary layer will remain well behaved as long as the pressure gradient in the flow direction does not exceed some experimental value of the pressure coefficient, C_p , defined

by

$$C_p = \frac{\Delta P_s}{1/2 \rho V^2} \quad (1)$$

where V is the free stream velocity and ΔP is the static pressure rise. The value of the pressure coefficient corresponding to separation lies in the range $0.4 < C_p < 0.8$. When the pressure gradient is not too large, viscous and shear stresses act on the slow moving fluid and keep it from stagnating. Under these conditions, the flow is well behaved (Fig 1). If the rate of area increase is large, the flow could experience unsteady zones of stall (Fig 2). The shear forces cannot overcome the pressure forces at all points in the flow. Therefore, local separation takes place. The main flow pattern changes due to the separation and relieves the pressure gradient. The boundary of the separation zone is usually unstable and the flow may become unsteady. However, sometimes the separation pattern becomes steady (Fig 3). Here the pressure coefficient, equation (1), is no longer valid. The flow will completely separate and behave much like a jet if the diffuser walls diverge rapidly (Fig 4). In this case, practically no static pressure rise takes place in the diffuser. Here again a pressure coefficient has no meaning.

In summary, stall in a diffuser should be avoided as it decreases the average stagnation pressure. This can be observed in the evaluation of the pressure coefficient which

represents an accepted figure of merit for the diffuser.

Kline describes relative diffuser performance in his experiments by means of a pressure recovery coefficient, C_{PR} , defined by (Ref 21)

$$C_{PR} = \frac{\frac{1}{A_2} \int_{A_2} PdA - \frac{1}{A_1} \int_{A_1} PdA}{\frac{1}{A_1} \int_{A_1} \frac{1}{2} \rho V^2 dA} \quad (2)$$

where A_1 and A_2 are the entrance and the exit areas, respectively, of the diffuser. There are various measures of diffuser performance or figures of merit. However, the two most commonly used are the pressure recovery coefficient, C_{PR} , just considered and the diffuser efficiency, η_D . The standard definition of diffuser efficiency, η_D , assumes that the diffuser exit velocity is negligible and the flow is a perfect gas (Ref 22).

$$\eta_D = \frac{\left(\frac{P_2}{P_1}\right)^{k-1/k} - 1}{\frac{k-1}{2} M_1^2} \quad (3)$$

Extensive diffuser research was performed by Kline during the late 1950's. He worked primarily with two dimensional straight wall and conical diffusers. Parametric

equations correlating two-dimensional straight wall, conical and annular geometries were developed (Ref 11). These will now be reviewed. Table I provides the geometrical relationship. The correlating variables are illustrated in Fig 5 for a two-dimensional straight wall diffuser and in Fig 6 for an annular diffuser. A common physical characteristic of the three types of diffusers is the area ratio. Kline's correlating equations (Ref 11) are

$$\text{Flat: } AR = \frac{A_2}{A_1} = 1 + 2 \frac{L}{W_1} \sin \theta \quad (4)$$

$$\text{Conical: } AR = 1 + 2 \frac{L}{R_1} \sin \theta + \left(\frac{L}{R_1}\right)^2 \sin^2 \theta \quad (5)$$

$$\text{Annular: } AR = \frac{1 + 2 \frac{L}{R_1} \sin \theta + \left(\frac{L}{R_1}\right)^2 \sin^2 \theta - \left(\frac{B_2}{R_1}\right)^2}{1 - \left(\frac{B_1}{R_1}\right)^2} \quad (6)$$

Kline indicates the model is in good agreement for correlating conical and flat units. Insufficient annular data existed to provide any real checks on the correlation suggested for flat and annular units (Ref 11). Thus another requirement for this annular diffuser data emerged. The data to be taken, when correlated to flat and conical diffusers using the above relationships, provides a basis for validating the per-

formance. At the same time, the data provides parameters for design. Numerous reports on two-dimensional plane wall and conical diffusers exist from which to obtain a data comparison. One of the best known was again one by Kline, Reneau, and Johnston published in 1967 (Ref 5). This study explored various flow regimes, locations of maxima of performance, varying length and area ratios, and recovery and loss coefficients.

The literature search indicated that four parameters need to be considered when analyzing diffuser type flow:

1. Minimum loss of total pressure for a given pressure rise
2. Maximum recovery for a given area ratio independent of length in the flow direction
3. Optimum recovery within a given length in the direction of flow
4. Optimum recovery for any possible geometry for the given inlet conditions.

The initial conditions or inlet conditions determine the nature of the flow and thus must be considered. Such parameters as boundary layer growth, swirl and turbulence intensities warrant attention.

Kline, as well as other researchers, has found that inlet turbulence has a significant effect on plane and conical diffuser performance. Although little is recorded in the literature about the effects of turbulence on annular diffusers, it is reasonable to assume a similar trend. In annular diffuser studies conducted thus far, it was found that the turbulence level, $\sqrt{\overline{v'^2}}/V$, is highest at the inner and outer radii and reaches a minimum near the center of the annular passage (Ref 33).

Diffuser flow has been and will continue to be an area of intense research. This is especially true for annular diffusers in gas turbine applications where availability and cost of fuel will put combustion efficiency at a premium.

Thus, it can be noted that diffuser research has been an on-going program since the early days of aerodynamics and continues to play a vital role in aerodynamic developments. Next, the design details of the apparatus developed in this investigation are presented.

III Design of Experimental Apparatus

The subsonic, axisymmetric, annular diffuser model was the culmination of design research. Requirements from AFWAL/POTC, the sponsor of the research under the guidance of Mr Dale Hudson, and input by the thesis committee were incorporated into the design.

Initial design constraints outlined by the sponsor included an inlet diameter of between 18 and 24 in, a one in minimum inlet channel height and an inlet Mach number range between 0.2 and 0.6. The mass flow rate at the maximum inlet Mach number could not exceed 22 lbm/sec.

Continuity was the major parameter which guided the design of the diffuser to meet the above specifications. Iterations on the continuity equation

$$\dot{m} = \rho AV \quad (7)$$

were performed. The optimum inlet diameter for the annular diffuser model was determined to be 20 in. With the one in inlet channel height, the effective flow area was 0.4145 ft².

Taking compressibility effects into account, the mass flow rate was expressed by (Ref 22)

$$\dot{m} = A \sqrt{\frac{k}{R}} \frac{P_s}{\sqrt{T_t}} M \sqrt{1 + \frac{k-1}{2} M^2} \quad (8)$$

For design calculations the static pressure and temperature were assumed to be ambient pressure and temperature.

Detailed data can be found in Table II. The maximum mass flow rate necessary was 20.2 lbm/sec. This provided a Mach .6 inlet condition. The minimum flow requirement was 6.75 lbm/sec which provided a Mach .2 inlet condition.

The constant area inlet section was made to be eight in long (Section A, Fig 7) to allow the establishment of a fully developed velocity profile. The length was a compromise between developing the flow and at the same time guarding against excessive boundary layer growth effects. The size of the boundary layer was estimated using flat plate theory at the outlet of the eight in section (Ref 34).

$$\frac{\delta}{x} = \frac{5}{\sqrt{Re}} \quad (9)$$

From this equation, the boundary layer height on one wall is 0.16 in.

Attached to the eight in inlet section was a four in diffusing section designed to be removable to allow testing various area ratios (Section B, Fig 7). The L/L ratio of the four in length is typical of gas turbine engine diffusing sections. The diffusing section had an area ratio of two. At the exit of the diffusing section the flow area was 0.8290 ft². This section was of most interest and is the heart of

the system. The velocity drop and the static pressure rise took place here and the effect of a full annular region on the flow behavior was of prime interest. The expected velocity at the exit of the diffusing section was calculated from

$$V = \frac{\dot{m}}{\rho A} \quad (10)$$

$$\rho = \frac{P}{RT} \quad (11)$$

Diffusing section exit conditions are found in Table III.

The four in diffusing section (Section B, Fig 7) opened into a dump with an area ratio of 4.5 (Section C, Fig 7.) This section models the entrance to the combustion region and provides the necessary mixing and additional velocity drop and static pressure rise for efficient combustion. For the dump area design calculations the density of the air was assumed to be ambient and the flow area was 1.865 ft². Diffuser dump flow conditions are found in Table IV. The dump extended for two ft beyond the four in diffusing section to prevent objects downstream from sending back pressure signals that might affect the flow in the diffuser. The annular diffuser model was created and built based on these calculations.

The final design of the diffuser model (Figs 7, 8,

and 9) was 20 in in diameter at the inlet. The axial annular sections consisted of an eight in constant area section with one in channel height, a four in diffusing section with an area ratio of two and a 24 in dump section with an area ratio of 4.5. The exit diameter was 23.5 in and the overall length was 36 in.

The apparatus was constructed around a superstructure consisting of a 48 in long, eight in diameter aluminum pipe with 1/4 in wall thickness. Built up around the superstructure was a wooden cylinder that formed the inside surface of the annulus at the front. The wooden cylinder tapered in at the diffusing section and cut in again at the dump. The built up wooden section was supported by plugs and metal beams. The beams extended to the front and rear of the apparatus and connected to vertical beams fastened to the table. The support struts were streamlined in order to reduce flow interference. The inside surface of the annulus (wood) was machined and smoothed to within 0.06 in of all specifications. In addition, the surface was painted with two coats of light-absorbing flat black enamel. This served a twofold purpose. One, the surface was made smooth and two, reflections from incident laser light would be kept to a minimum.

Plexiglass was used as the outside surface of the

annulus. This material was chosen over both metal and wood because of the necessity to have visual access to the flow. There were other advantages inherent to the plexiglass. Probes were aligned properly by visually positioning them with respect to the flow. Traversing the flow radially was completed with confidence by visually verifying a probe's position. In the event there were areas of flow separation, tufts could be installed and such zones located. This outer plexiglass shell was aligned such that all channel heights, area ratios, and other dimensions were as specified in the design (within 0.06 in).

As stated earlier, the apparatus had a removable diffusing section and thus was made in three parts: the inlet section, the diffusing section, and the dump section. There were flanges at the front and back of each section with bolts spaced no more than two in apart around the annulus to connect the flanges. There was a rubber gasket between each section to eliminate air leakage. The gasket was trimmed to provide a continuous inner surface.

The table that supported the diffuser was designed and built specifically for this project. It was 10 ft long and 18 in wide. The height to the midline of the diffuser was 40.75 in. This was necessary for the laser doppler velocimeter (LDV) access to the flow section. The laser beams were at a height of 40.75 in from the floor. The

table was leveled to provide absolutely parallel flow to the floor. It was also made to be a stable platform with no movement due to small disturbance forces.

In order to simulate the design flow field, inlet guide vanes (IGV's) were installed. The IGV system was attached to the front end of the diffuser by plexiglass flanges and bolts. The IGV's consisted of 66 symmetric airfoils with a solidity of 1 and a $3/4$ in chord length. NACA 0012 airfoils were used. The angle of attack of the IGV's could be adjusted from -10 to $+10$ deg. All airfoils could be moved simultaneously and a prescribed angle of attack input by means of set screws. The IGV's flow area and channel height were matched to the diffuser inlet. In addition to the rubber gasket, a foam rubber gasket was added to provide a smooth transition between the IGV's and the inlet. The vanes were used to both straighten and provide swirl to the flow. Beyond ten deg, flow separation from the IGV's could possibly become a problem and limit the turning. The vanes were fashioned out of wood and covered with enamel paint for smoothness.

Phase I of the testing was scheduled to use the house air of AFIT Building 640 where a limited mass flow rate is available ($0.5 - 1.5$ lbm/sec at 80 psia). Phase II of the testing will involve the new flow generating facility of AFIT Building 640 where a higher mass flow rate will be

available. The facility is in the final stages of development and will be available by mid-1982 for hook up to the diffuser apparatus.

To accommodate Phase I testing, the diffuser flow region was restricted to a 120 deg section. This allowed taking data at no more than two stations around the annulus at one time. The flow source was a three in inner diameter pipe. The flow was expanded from this pipe to the 120 deg annular section by means of a specially designed double cone section (Fig 10). First, two cones were turned on a lathe to match the outer and inner radii, respectively, of the diffuser inlet. Fiberglass was laid up on the plugs and a 120 deg section cut out of each fiberglass form. Walls were attached to enclose the flow area along with wooden flanges to bolt the cone onto the IGV's. The area ratio between the inlet to the diffuser and the pipe flow was 8.4. The inlet cone was acting as a diffuser and as such was subject to stall and flow separation. Using Kline's (Ref 30) work, the optimum length was approximately 36 in (Fig 10). The inlet cone was connected to the three in pipe source via a 12 in long flexible rubber connection and fastened with adjustable pipe clamps.

Necessary accessories to the 120 deg section inlet cone were diffuser inserts. They would keep the flow throughout the annular diffuser confined to a 120 deg section. The inserts were machined of wood and fit the contour of the flow

field in the radial direction. Heavy felt was attached to the edges of the inserts to seal the flow area (Fig 11). The inserts and the inlet cone were used for Phase I of the testing to drive the diffuser at the highest possible Mach number of .14.

The preliminary testing was accomplished at AFIT Building 640 with the 120 deg annular section in place. The second phase of the testing is planned at AFIT Building 640. With these two phases completed, the rig with experimental subsystems less automatic data acquisition will be moved to AFWAL/POTC for final testing.

Thus, the apparatus and complementary subsystems were designed and fabricated. The variety of instrumentation systems used will be considered next.

IV Instrumentation

The research program permitted a simultaneous development of the instrumentation package and the facility design. The instrumentation package provides inputs to an automatic data acquisition and processing system (ADAPS). This provided an opportunity for the instrumentation package and facility design to complement each other. For example, the outer shell of plexiglass provided flow visualization and visual positioning and alignment of the probes. Also, the inner shell was painted flat black to reduce reflected laser light from the LDV.

Three instrumentation systems were used in this project: pitot tube system, hot wire anemometer, and LDV system. In addition, the ADAPS was used due to its availability at both AFIT and AFWAL/POTC.

Three pitot tubes were used for the purpose of obtaining static and total pressures and mean velocities. The pitot tubes were of ASME test code design and manufactured by the United Sensor Company. The pitot tubes selected were 1/16 in diameter (Fig 12). This yielded between one and six percent blockage in the flow duct bounded by adjacent guide vanes and the inner and outer walls of the apparatus. Each pitot tube was equipped with both a total pressure port and static pressure ports. The pressure

signals from the pitot tubes were fed through tubing into electrical pressure transducers (Fig 13). One pressure transducer was provided for each pitot tube exit port. A water manometer system was installed parallel to the transducers as a backup and validating system for the preliminary work. The electrical signals from the pressure transducers were transmitted to digital voltmeters with the capability to be fed into the HP 9845/B. Calibration curves plotting pressure versus voltage (Figs 26, 27) were obtained for each pressure transducer. The voltages were converted to total and static pressures. The calibration curves were all found to be linear (Figs 26, 27). The transducers were differential pressure transducers in the 0-2 psid range. One pressure port on the transducer was connected to the pitot tube and the other port was left open to the atmosphere. The differential pressure from the transducer was added to ambient pressure for the actual pressure reading. By forming P_s/P_t and reading T_t from a thermometer inserted in the air supply and then with the aid of the Gas Tables (Ref 32), the Mach number, static temperature and velocity were obtained (Table 5). The velocity was derived from

$$V = a M = M \sqrt{k R T_s} = M \sqrt{k R \left(\frac{T_s}{T_t}\right) T_t} \quad (12)$$

The pressure transducers' complementary electronics included a 10 volt power supply and a 10 channel switching and balanc-

ing unit. The transducers required voltmeters with millivolt sensitivities.

The Thermo Systems Inc (TSI) model 1050 hot wire anemometer system was used for the dual purpose of obtaining velocities as well as turbulence intensities. The complete 1050 series instrument consists of a controlled bridge and amplifier circuit, a power supply and DC readout circuit. The transducer used with the 1050 series anemometer is a small resistance element which is heated and controlled at an elevated temperature. The amount of electrical energy dissipated in the sensor is a measure of the cooling effect of the fluid flowing past the heated sensor. This depends on both the mass flow and temperature difference between the sensor and the fluid. The relationship between bridge voltage and mass flow is as follows (Ref 35):

$$\frac{E^2 R}{(R + R_3)^2} = (A + B (\rho v)^{1/n}) (t_s - t_e) \quad (13)$$

where A, B = constants depending on fluid and type of sensor.

ρ = density of the gas or liquid

V = velocity

n = exponent (close to 2)

t_s = sensor operating temperature

t_e = fluid temperature

$t_s - t_e$ = typically 225°C in air

R = sensor operating resistance
R₃ = resistor in series with the sensor
E = bridge voltage

All tests were conducted with a hot film sensor (Fig 14). Hot film sensors have properties that are best for most applications. The hot film sensor used in Phase I testing was 0.001 in in diameter. This sensor provided the necessary frequency response and ruggedness for continuous use in the diffuser flow field. Included here were all Mach numbers of interest and the accompanying levels of turbulence. The hot film sensor was calibrated using the ADAPS and software developed by Captain Mike Kirchner (Ref Unpublished Thesis). Velocities between 2 and 222 ft/sec were plotted versus voltage(Fig 15). Using a polynomial curve fitting technique a fourth degree polynomial was found to fit the points (Fig 15). The polynomial is

$$V = A + B(\text{Volts}) + C(\text{Volts})^2 + D(\text{Volts})^3 + E(\text{Volts})^4 \quad (14)$$

The constants for the particular hot film sensor used in Phase I of the testing can be found in Fig 15.

The output voltage from the constant temperature anemometer was fed into the digital voltmeter and the readings entered into the fourth deg polynomial for mean velocities. The turbulent component of the velocity was found by inputting the voltage from the TSI model 1050 constant

temperature anemometer into an RMS voltmeter. This voltage was used in conjunction with a manipulated form of the fourth degree polynomial to calculate the turbulent component of velocity (Appendix C).

$$d \text{ (Vel)} = B + 2 C \text{ (Volts)} + 3 D \text{ (Volts)}^2 + 4 E \text{ (Volts)}^3 \quad (15)$$

Alternatively, the voltages could be fed into the ADAPS and processed by existing software.

The laser doppler velocimeter (LDV) is a non-intrusive tool and has gained support for use in aerodynamic research. The LDV has not by far reached its full usage potential. Its incorporation into the diffuser model is an effort to fully evaluate its potential while at the same time develop techniques that apply strictly to the diffuser flow problem. The LDV system employed was the TSI system 9100-6, single channel optics and a Spectra Physics 165-04 four watt Argon-Ion laser. Signal processing was accomplished by the TSI Model 1990 counter type signal processor. In this study, the LDV was operated in the on-axis backscatter mode at a wavelength of 4880 Å. This LDV system was selected because of the high degree of measurement sophistication inherent in the system. The frequency response of the counter type signal processor is 200 MHz. The optics and signal processing were complementary and provided one of the highest signal

to noise ratios available on the market today. This system was optimized for superior performance in the backscatter mode.

Obtaining useful data with the LDV depended on the following:

1. The transparent fluid flow field, including acceptable particle concentration and size.
2. The optics
3. The alignment of the laser and optics
4. The photodetector
5. The signal processor
6. The data reduction process.

Items 2, 4, and 5 were fixed parameters. Item 1, particle concentration and size, was an extremely important consideration. Preliminary checking on the air system indicated that the natural seeding was marginal. Nevertheless, testing is to continue as a flow seeding device is scheduled for early 1982. The data from the frequency counter were directly affected by the particles that reflected the laser light as they passed through the control volume. The control volume was formed by the intersection of two laser beams and had dimensions of 0.61 mm X 84 μ m X 84 μ m (Fig 17). The optimum particle concentration for this system was chosen to be a five percent probability of more than one particle in the

measuring volume (Ref 36). Particle size had a direct impact on the data because of its importance in relation to the fringe spacing in the control volume (Fig 17).

$$\begin{aligned}
 \text{FS} &= \frac{(\lambda) (\text{FL})}{(\text{BEF}) (\text{BS})} && (16) \\
 &= \frac{4880 \text{ \AA}}{(3.75) (35\text{mm})} && = 1.79 \text{ \mu m} \\
 &&& \frac{480.2\text{mm}}{480.2\text{mm}}
 \end{aligned}$$

The focal length of the lens was adjusted for the light bending effect of the laser windows. The particle size should be smaller than the fringe spacing to obtain the most accurate frequency count as the particle traverses the control volume.

The LDV was used to measure the velocity of the particles which was assumed to be identical to the velocity of the fluid. There are several methods of data processing used by LDV systems. This particular system used a frequency counting technique which measures the doppler frequency shift of each particle as it crosses the fringes in the control volume. Then the velocity can be found one of two ways. First, multiply the doppler frequency measured by the fringe spacing. This requires accurate determination of the fringe spacing. An alternative is to use

$$f_d = \frac{2 V \sin \kappa}{\lambda} \quad (17)$$

and solve for velocity. The resultant velocity component will be perpendicular to the fringes. This particular frequency counter had the capability for direct readout of velocities and was used during Phase I of the testing. The counter also had digital data lines. An interface to the HP 9845/B computer-controller has been designed and is near completion for use in Phase II of the testing. The desired end products were mean velocities and turbulence levels.

The LDV system can be expanded in future applications of this diffuser-instrumentation system. Additional optics to measure velocities in more than one direction would offer new insights into improved diffuser designs. Turbulent flow could be studied with a non-intrusive instrument.

The instrumentation systems provide the necessary capability to collect data for pressures, velocities, and turbulence intensities. Continued testing with the aid of this model will yield the required data to fully evaluate the performance capabilities of annular diffusers.

In an effort to provide accurate and varied instrumentation access along and around the diffuser, an axial traversing mechanism was designed and built (Fig 18). It was constructed so that all peripheral data stations at one axial point could be used either simultaneously or individually. The axial traversing system was moved manually along tracks

between axial points. These tracks were at floor level but were bolted to the diffuser table for stability and absolute positioning control. The traversing system could be locked into place at three axial locations. At four points on the axial traversing system, motorized traversers were bolted on (Fig 18). Once the axial traversing system was locked into place, the motorized traversers moved the hot film sensor and the pitot tubes radially through the flow. They were controlled through a switch box and could be activated both individually and together. Length scales on the motorized traversers determined radial position to within 1/16 of an in. The motor's speed was 1/10 in/sec. This allowed careful positioning in the diffuser flow area. To provide more capability for follow on researchers, two, two channel absolute encoders are available and can readily be integrated to the instrumentation to determine position within .001 in. The interface has been designed and fabricated.

Thus, the instrumentation was selected to gather the most informative data in the most efficient manner. The next chapter considers the integration of the diffuser and its instrumentation and experimental techniques.

V Integrated Systems and Experimental Techniques

The apparatus has been designed and fabricated. The instrumentation systems have been selected. Both were designed to provide the greatest determination of the flow parameters such as pressure coefficient, turbulence intensity, pressure gradient, total pressure gradient and velocity profiles. Three points along the axis of the diffuser were identified for the entry of the instrumentation systems (Fig 7). The first point was in the constant area inlet section three in downstream of the inlet section flange (Fig 7). Here, inlet conditions of pressure, velocity and turbulence intensities are to be measured. This will provide data on the nature of the flow provided by the 120 deg inlet cone and the IGV's. In addition, the impact of inlet conditions on the performance of the diffusing section could be evaluated. The second axial data point was one in downstream of the entrance to the diffusing section (nine in from the inlet flange). Ideally, data should be taken at many points all along the diffusing section. For preliminary testing, one point was chosen to provide the most informative data. The third point was two in downstream of the diffuser dump inlet flange (15 in from the inlet flange). The area ratio changed from 2 to 4.5 via a step function. This was the farthest downstream that meaningful data was needed. As the research program progresses and the need for additional axial data points arise, the

plexiglass outer shell is ideally suited for the addition of additional test stations. The design condition of three axial data points was instrumented with three pitot tube systems, a hot wire anemometer system and an LDV system. At each axial test point, five peripheral stations were chosen around the annulus to access the flow for the pitot tubes, the hot film sensor and the LDV laser beams (Fig 8).

Three of the five stations were chosen as the pitot tube access ports (Fig 8). One was located directly in the axial horizontal plane, one at 60 deg from the horizontal plane, and one at 135 deg from the horizontal. This spacing was necessary to detect the presence of cyclical flow behavior. The access holes were 1/4 in in diameter and rubber plugs prevented air leakage around the pitot tubes. In addition, a pitot tube could be used in the hot film sensor access port through a special adaptor plug. The pitot tubes traversed the flow radially by means of the motorized traversers. The alignment of the probes was done visually to ensure parallelism to the flow. Specially designed metal blocks held the pitot tubes rigidly to the motorized traversers. Plastic tubing connected the pitot tubes and the pressure transducers. Electronics to support the pitot tubes were the pressure transducers (Fig 13), a 10 channel switching and balancing unit (Fig 13), a 24 volt power supply (Fig 13), and one voltmeter for each pressure transducer.

The hot film sensor access port was located top vertical (Fig 8). The access port was 1/2 in in diameter and a rubber plug prevented air leakage around the hot film sensor. The hot film sensor traversed the flow radially by means of a motorized traverser. The alignment of the sensor was done visually to ensure perpendicularity to the flow. A specially designed metal block held the hot film sensor assembly rigidly to the motorized traverser. The output from the constant temperature anemometer was fed to both a digital voltmeter and an RMS voltmeter. The digital voltmeter read-out was entered into the fourth deg polynomial (Eqn 14) determined in Chapter 4. This converted the voltage to the steady state velocity. The RMS component of the voltage was used to find the turbulent velocity component (Eqn 15).

The LDV had the advantage of causing the least interference with the flow. The two LDV laser beams passed through interferometer quality, two in in diameter, glass windows. The windows were .389 in thick, nominal, and flat to within 1/20 of one sec of a deg. They were installed on the horizontal 180 deg from the axial horizontal pitot tube access (Fig 8). To avoid propagation of the two laser beams through the plexiglass, a 1.5 in by 3/16 in slot was cut out at each of the three LDV access stations. The laser window and its holder were attached to the outside plexiglass surface of the diffuser. The window and holder were centered over each slot and sealed with epoxy (Fig 19). A rubber gasket was

located between the window and the holder to seal the area. There will be a small cavity effect due to the slots cut out of the plexiglass. This should not affect the data as long as the LDV laser control volume is kept at least 1/4 in from the inside surface of the outer plexiglass wall. There were three windows and three specially designed plexiglass holders made to fit the contour of each of the three axial LDV data stations, respectively (Fig 19). The height from the floor to the slots was 40.75 in. The laser and optics were mounted on an aluminum breadboard mounting base. It was 72 in long, 24 in wide, 2.5 in high, and weighed 108 lbs (Fig 16). It provided a flat, rigid surface on which to position and align the laser and optics. This mounting base was placed on a table to provide a rigid and stable laser and optics platform. It also provided a laser beam height of 40.75 in from the floor. The accompanying laser power supply and LDV frequency counter plus oscilloscope were located directly adjacent to the laser and optics platform (Fig 20). The LDV laser beams were aligned with the windows and slots by manually moving the diffuser apparatus.

The five diffuser access stations for the three pitot tubes, one hot film sensor, and one LDV system were provided at each of the three data acquisition points along the axis of the diffuser.

The designed method of instrumentation allowed

simultaneous data acquisition at the five stations of one axial data point. The accurate determination of flow characteristics around the annulus was the goal. Radial velocity, turbulence intensity and pressure profiles could be determined at any instrumented point. The various instrumentation systems were used for two purposes. One was to analyze annular diffuser flow behavior. The other was to establish the attributes of each instrumentation system when used in an annular diffuser flow environment.

The inlet guide vanes (IGV's) could be used to both straighten and impart swirl to the inlet flow. In the zero deg swirl setting, the IGV's straightened the flow. Data taken with zero swirl during Phase I baseline testing could be compared with Phase II testing which will consider the effects of swirl.

The inlet cone expanded the three in pipe source flow to the 120 deg annular section. The data obtained in this configuration could be compared to that obtained with a different annular section.

Preliminary testing used two compressors for a one lbm/sec mass flow at 60 psi. This was the maximum capability of the air delivery system at the time and resulted in a maximum Mach number for the 120 deg annular section of 0.14. All preliminary testing was at this value. Once

steady state flow had developed (5 minutes), the probes and motorized traversers were zeroed with the probes positioned visually at the inner surface of the outer plexiglass wall. Radial profiles of pressure, velocity, and turbulence were obtained by observing the flow at five radial positions. This procedure was repeated at each axial data acquisition point.

The completed installation presented a fully integrated system of both test apparatus and instrumentation. In addition to the manual processing of raw data, the HP 9845/B could be integrated to the instrumentation. Appropriate software guidelines are on file in the Department of Aeronautics and Astronautics of AFIT/EN. This makes it possible in the future to analyze, examine, and compare a large volume of collected data for a thorough investigation of diffuser flow.

Thus, the preliminary data gathering was accomplished. In Chapter 6, the results of the preliminary testing which will provide a baseline will be discussed.

VI Results and Discussion - System Evaluation

The full 360 deg annular diffuser and associated instrumentation have been assembled and integrated. Preliminary testing was accomplished with the 120 deg section inlet cone in place for a total inlet area of 0.1382 ft². The mass flow rate was one lbm/sec at 60 psi which yielded a maximum Mach number of 0.14.

Some general comments are appropriate. The annular diffuser apparatus generated a high level of acoustic noise when operated. The level of noise occurring at such a low Mach number indicated flow separation either in the inlet cone or in the diffuser or both. The flow through the inlet cone did not fully expand and was limited to an approximately 90 deg section. This is an example of jet flow in a diffuser (Fig 4). The failure of the inlet cone to provide a fully expanded flow to the diffuser inlet suggests that another method be used to provide the inlet flow. This new method can be in the form of a 60 deg inlet cone or the addition of a plenum chamber just upstream of the IGV's. The impact of the present 120 deg inlet cone flow on the preliminary data could be large. The areas of separation in the inlet cone could be unsteady and therefore the inlet cone would provide varying inlet conditions to the diffuser. This could explain the disparity in pitot tube and hot film velocities which is

discussed below. Flow integrity (no leakage) was maintained throughout many transition sections (pipe and inlet cone, inlet cone and IGV's, IGV's and diffuser inlet). The axial traversing system positioned the motorized traversers and the probes exactly over the access ports to the diffuser flow field. The motorized traversers moved the probes radially through the flow to obtain pressure and velocity profiles (Figs 21-25). This was done at all three axial instrumentation points.

The operation of the diffuser is next considered in relation to each of the three instrumentation systems. The pitot tube system is considered first. The pitot tubes were easily mounted in the flow and accurately positioned. This was important due to the sensitivity of the pitot tube in relation to the flow direction. The Bell and Howell 0-2 psid pressure transducers did not yield the desired sensitivity at the low pressures that were encountered. Their reliability will increase as more mass flow becomes available. To counter any inaccuracies in the data obtained with the pressure transducers, a parallel water manometer was installed. The damping encountered in the water manometer system made the collection of reliable data possible. The data from both the water manometer system and the pressure transducer system showed the same general trends in the pressure and velocity profiles (Figs 21-24). Data for the pitot tube system with pressure trans-

ducers are found in Table V. Data for the pitot tube system with the water manometer are found in Table VI. Velocities derived from pressure ratios suffered in the pressure transducer data. This was due to the lack of precision in the pressure readings. Fluctuating voltmeters due to small ΔP caused the lack of precision. This will improve as m increases resulting in larger ΔP values.

A hot film sensor was used with the hot wire anemometer system. Calibration and data reduction were accomplished with the aid of the HP 9845/B computer-controller. The hot film sensor data indicated a higher inlet velocity than the pitot systems. However, the same trends were apparent in the velocity profiles measured by each of the instruments (Figs 23-25).

The laser doppler velocimeter (LDV) system's sensitivity to particle concentration and size was the limiting factor in data collection. Natural seeding was inadequate to obtain reliable and reproducible data with the LDV. The alignment of the optics at a laser wavelength of $+880 \overset{\circ}{\text{A}}$ was verified by procedures outlined by TSI, the manufacturer. The optical laser path to the diffuser flow field was exactly positioned through the slot cut out of the plexiglass diffuser wall. The only interference to the laser beams were the laser windows. These provided the least possible interference due to their quality and positioning. The addition

of a flow seeder in early 1982 will enable the collection of reliable and accurate data by the LDV system. Mean flow velocities may then be determined.

The comparison of velocity data for the hot film sensor and the pitot tube can be made from Table VIII and Fig 28. The velocity data showed general trends of the performance of the diffuser. The inlet velocity profile was fairly uniform (Figs 23-25). The turbulence intensity was .10 (Table VII). Upon entering the diffusing section, the velocity began to decrease and was non-uniform across the channel height (Figs 23-25). Some separation was indicated in the diffusing section. The flow velocity near the inside wall was 1/2 to 1/3 that of the rest of the radial velocity profile (Tables V-VI). The diffusing section turbulence intensity was also about .10 (Table VII). The diffuser dump data showed a turbulent region with separation (Tables V-VII). The flow velocity varied by as much as 600% in the radial direction in the dump section. The pitot tubes were yielding $P_s/P_t > 1$ (Tables V-VI). This indicated reverse flow. The turbulence intensities were as great as .50 in the dump section (Table VII).

Static pressure was increasing between the inlet and diffusing sections. The total pressure was remaining approximately constant. For this low speed flow Bernoulli's equation for incompressible flow was valid and could be used to deter-

mine velocities. In the dump section there were both static and total pressure drops. For an ideal one dimensional diffuser, C_{PR} can be expressed as (Ref 21)

$$C_{PR} = 1 - \left(\frac{A_1}{A_2}\right)^2 \quad (18)$$

This equation yielded an approximation of C_{PR} for the diffusing section of the annular diffuser of

$$C_{PR} = .75 \quad (19)$$

Preliminary testing with the 120 deg diffuser segment has verified that the instrumentation systems are performing as designed. Therefore, the next step is the integration of the HP 9845/B computer-controller to the test rig. Digital data lines for the hot wire anemometer and the pitot tube system are in place. A computer interface for the frequency counter in the LDV system is designed and near completion.

The annular diffuser has been built and is ready for full scale evaluation. The 120 deg segment of the diffuser, which was used in this investigation for evaluation of instrumentation systems and their adaptation for computer analysis of data, has some flow anomalies which must be corrected before it can be used for preliminary evaluation of the full-scale diffuser performance. The flow traversing mechanisms and data acquisition and processing electronics are operating and capable of furnishing the preliminary data.

The conclusions drawn from this investigation are listed in the next section.

VII Conclusions

The following conclusions can be made as a result of the design and preliminary testing.

1. A test facility with associated instrumentation has been designed, fabricated, and installed.
2. The final integration of the HP 9845/B computer-controller to the diffuser apparatus and instrumentation is ready to begin.
3. The total traversing system proved to be a stable platform that led to accurate positioning of the instrumentation and efficient data collection.
4. The laser doppler velocimeter system data acquisition depends on particulate matter in the flow. The natural seeding was not adequate for useful data collection. A flow seeding device is needed to effectively collect reliable LDV data.
5. The preliminary experimental results may be used as an indication of instrumentation suitability and capability.

VIII Recommendations

The following recommendations are made as a result of the present investigation.

1. Install plenum chamber and construct a 60 deg version of the 120 deg inlet cone.
2. Obtain a flow seeding device to control the size and density of particles in the flow.
3. Provide 4880 Å and 5145 Å color filters for the photodetector of the LDV system. This will improve the signal to noise ratio.
4. Incorporate frequency shifting into the LDV system to improve the signal to noise ratio.
5. Obtain screens for generating turbulence and insert upstream of the IGV's.
6. Expand the LDV system optics to two channel operation in order to obtain two components of velocity at one time.

Bibliography

1. Cocanower, A. B., Kline, S. J., and Johnston, J. P. "A Unified Method for Predicting the Performance of Subsonic Diffusers of Several Geometries." Stanford University, Report PD-10, May, 1965.
2. Titcomb, S. C., and Fox, R. W. "Prediction Methods for Turbulent Incompressible Flow in Conical Diffusers." Purdue Research Foundation, FMTR-65-2, July, 1965.
3. Reneau, L. R., Johnston, J. P., and Kline, S. J. "Performance and Design of Straight Two-Dimensional Diffusers." Stanford University, Report PD-8, September, 1964.
4. Sprenger, H. "Experimental Investigations of Straight and Curved Diffusers." Mitt, Inst. Aerodyn. Zurich, 1959.
5. Reneau, L. R., Johnston, J. P., and Kline, S. J. "Performance and Design of Straight, Two-Dimensional Diffusers." ASME Journal of Basic Engineering, March, 1967.
6. McDonald, A. T., Fox, R. W., and Van Dewoestine, R. V., Effects of Swirling Inlet Flow on Pressure Recovery in Conical Diffusers, AIAA Journal, 9 No. 10, 2014-2018, 1971.
7. Cockrell, D. J., and King, A. L., Flow Through Diffusers. Ruhr Universitat Fochum, Lehrstuhl Fur Stromungs Maschinen.
8. Sovran, G., and Klomp, E. D., Experimentally Determined Optimum Geometries for Rectilinear Diffusers with Rectangular, Conical or Annular Cross-Sections. Fluid Mechanics of Internal Flow, Sovran, G., ed., Elsevier, Amsterdam, 270-319, 1971.
9. Schwartz, I. R., Investigations of An Annular Diffuser-Fan Combination Handling Rotating Flow. NACA RM No. L9B28, 1949.

10. Srinath, T., An Investigation of the Effects of Swirl on the Flow Regimes and Performance of Annular Diffusers with Equal Inner and Outer Cone Angles. University of Waterloo, Ontario, Ph.D. Thesis, 1968.
11. Kline, S. J., Abbott, D. E., and Fox, R. W. "Optimum Design of Straight-Walled Diffusers." ASME Journal of Basic Engineering, September, 1959.
12. Schneider, U. H., Effects of Inlet Swirl on Annular Diffuser Performance. University of Windsor, Ontario, M.A.Sc. Thesis, 1971.
13. Brighton, J. A., and Jones, J. B., Fully Developed Turbulent Flow in Annuli, J. of B. Eng., 86, 835-844, 1964.
14. Johnston, I. H., The Effect of Inlet Conditions on the Flow in Annular Diffusers. National Gas Turbine Establishment, C, P. No. 178, Memorandum No. M. 167, 1953.
15. Henseler, H. J., and Howard, J. H. G., Flow Regimes and Performance of Annular Diffusers with Equal Inner and Outer Cone Angles. University of Waterloo, Research Report No. 3, 1966.
16. Howard, J. H. G., Henseler, H. J., and Thornton-Trump, A. B., Performance and Flow Regimes for Annular Diffusers. Trans. ASME, Paper No. 67-WA/FE-21, 1967.
17. Yeh, H., Boundary Layer Along Annular Walls in a Swirling Flow. Trans. ASME, 80 No. 4, 1958.
18. Sagi, C. J., and Johnston, J. P. "The Design and Performance of Two-Dimensional, Curved Diffusers." Parts I and II, ASME Journal of Basic Engineering, December, 1967.
19. Migay, V. K. "The Effect of Initial Turbulence on the Efficiency of Diffuser Flows." Izvestiya Vsshikh Uchebnykh Zavendeniy Energetika, No. 2, 1966.

20. Project Squid - DoD Colloquium on Gas Turbine Combustor Modeling. Report No. PU-RI-79, Purdue University, November, 1979.
21. Hill, P. G., and Peterson, C. R. Mechanics and Thermodynamics of Propulsion, Addison-Wesley Publishing Co, Inc, 1970.
22. Shapiro, A. H., The Dynamics and Thermodynamics of Compressible Fluid Flow, Vol. 1, Ronald Press Co., 1953.
23. McDonald, A. T., and Fox, R. W. "An Experimental Investigation of Incompressible Flow in Conical Diffusers." Int. J. Mech Sci., Vol 8, p 125-139, 1966.
24. Cockrell, D. J., and Markland, E. "A Review of Incompressible Diffuser Flow." Aircraft Engineering, October, 1963.
25. Waitman, B. A., Reneau, L. R., and Kline, S. J. "Effects of Inlet Conditions on Performance of Two-Dimensional Subsonic Diffusers." ASME Journal of Basic Engineering, p 349-360, September, 1961.
26. Okiiski, T. H., Serovy, G. K., "Experimental Study of Turbulent Flow Boundary Layer Development in Smooth Annuli." ASME - Paper 67 - WA/FE-10, Nov 12-17, 1967.
27. Clump, C. W., Kwasnoski, D., "Turbulent Flow in Concentric Annuli." A.I.Ch.E., J V14 n 1, p 164-168, January, 1968.
28. Migay, V. K. "On Improving the Effectiveness of Diffuser Flows with Separation." Mekhanika i mashinostroyeniye, No. 4, 1960.
29. Stevens, S. J., Williams, G. J., Nayak, U. S. L., "Influence of Inlet Conditions on the Performance of Annular Diffusers." Proc. Jt. Symp. on Design and Oper. of Fluid Mach., Colo. St. University, Ft Collins, Jun 12-14, 1978, Vol 1, p 277-290.

30. Kline, S. J., "On the Nature of Stall." *Journal of Basic Engineering*, 81, Series D, No. 3, September, 1959, pp 305-320.
31. Patterson, G. N., "Modern Diffuser Design", *Aircraft Engineering*, Vol 10, 1938, pp 267-273.
32. Keenan and Kaye, Gas Tables, Wiley and Sons, 1948.
33. Coladipietro, R., Schneider, J. H., Sridhar, K., "Effects of Inlet Flow Conditions on the Performance of Equiangular Annular Diffusers", CSME Paper No 73-CSME-84, EIC Accession No 1542, ASME-CSME Fluids Engineering Conference, Montreal, Quebec, May 13-15, 1974.
34. Schlichting, Hermann, Boundary Layer Theory, McGraw-Hill Book Co., 1979.
35. General System Information for 1050 Series Anemometry, TSI Inc.
36. Technical Bulletin 25, Laser Velocimetry Technical Data, TSI Inc.
37. Gibson

Appendix A

Figures

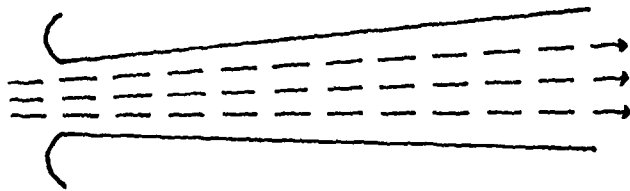

Figure 1. Well-Behaved Diffuser Flow

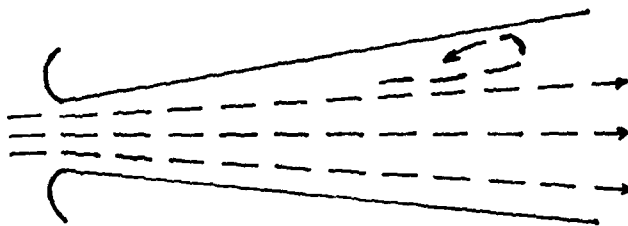

Figure 2. Unsteady Stall in a Diffuser

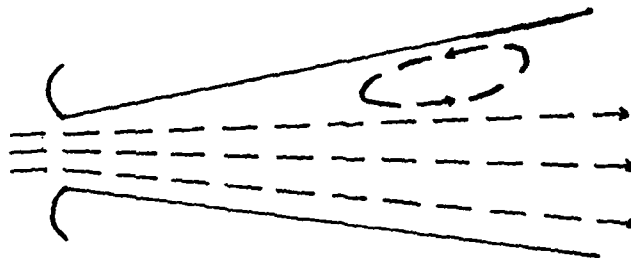

Figure 3. Steady Stall in a Diffuser

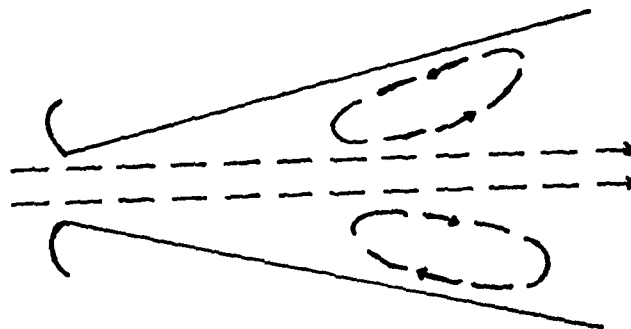

Figure 4. Jet Flow in a Diffuser

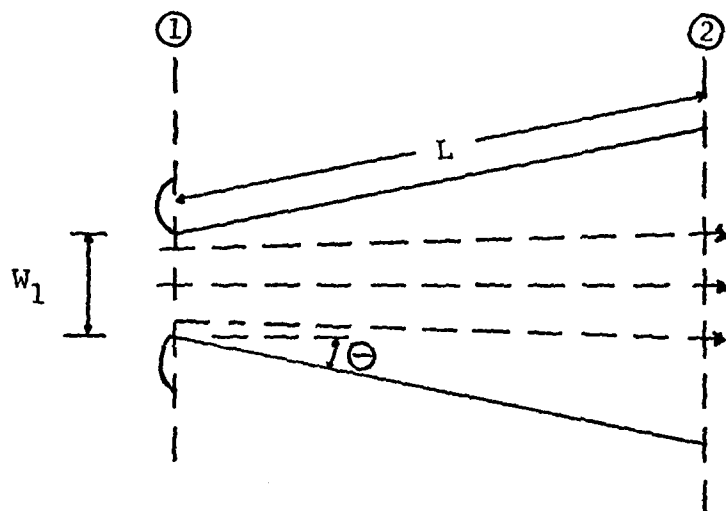

Figure 5. Two Dimensional Straight Wall Diffuser Dimensioning Nomenclature

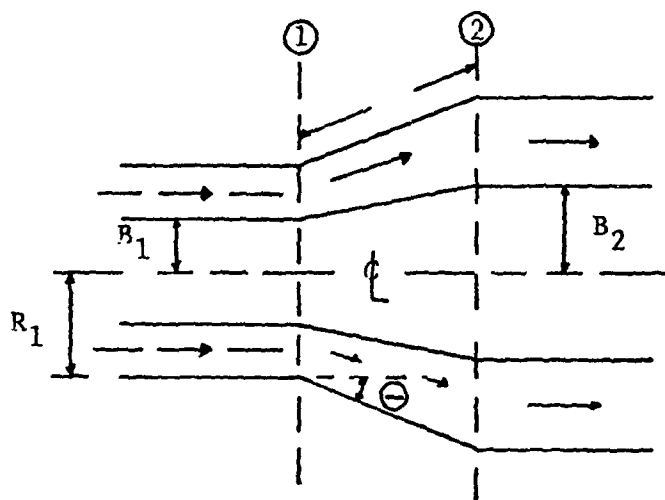

Figure 6. Annular Diffuser Dimensioning Nomenclature

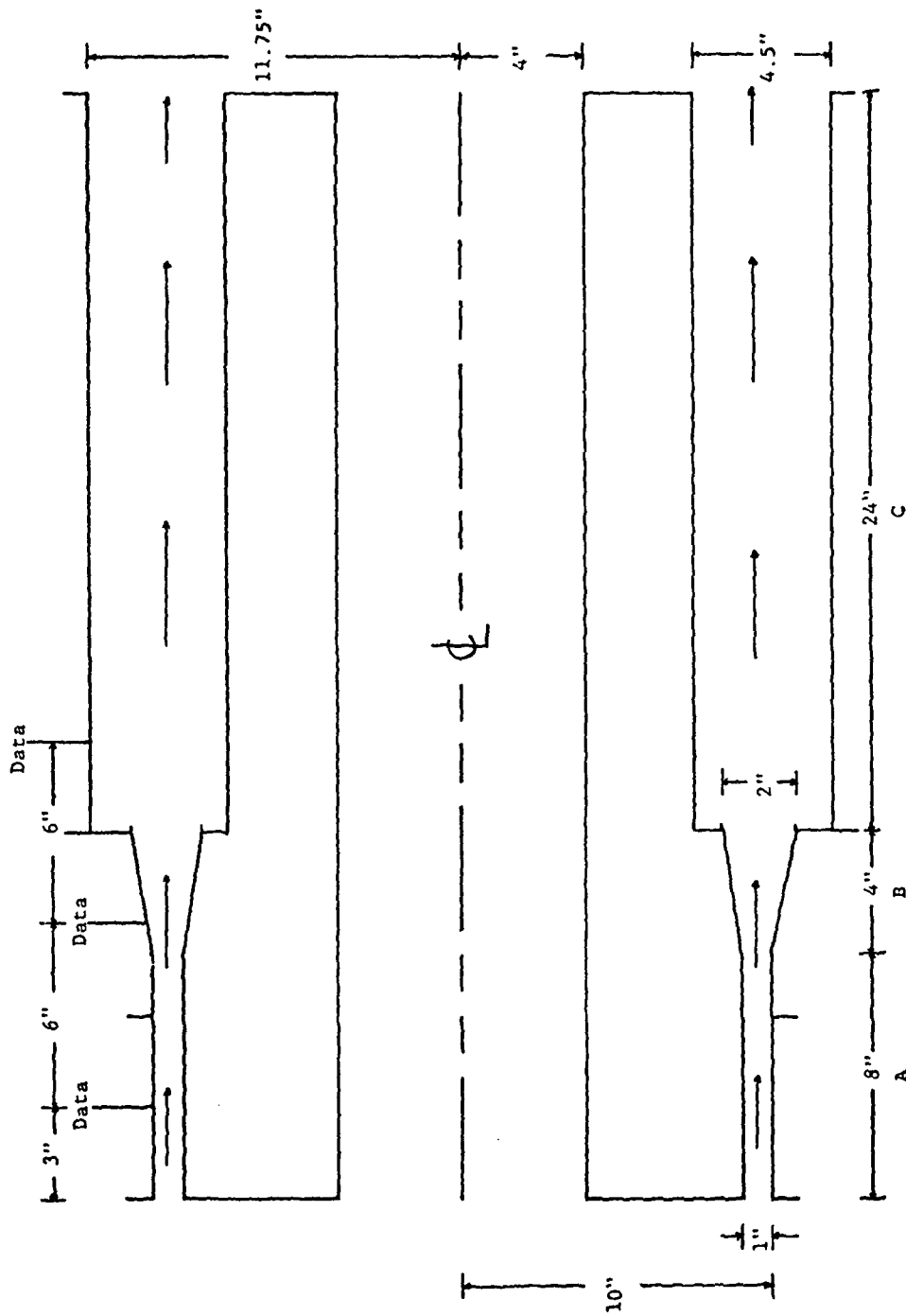

Figure 7. Cross Sectional View of Annular Diffuser

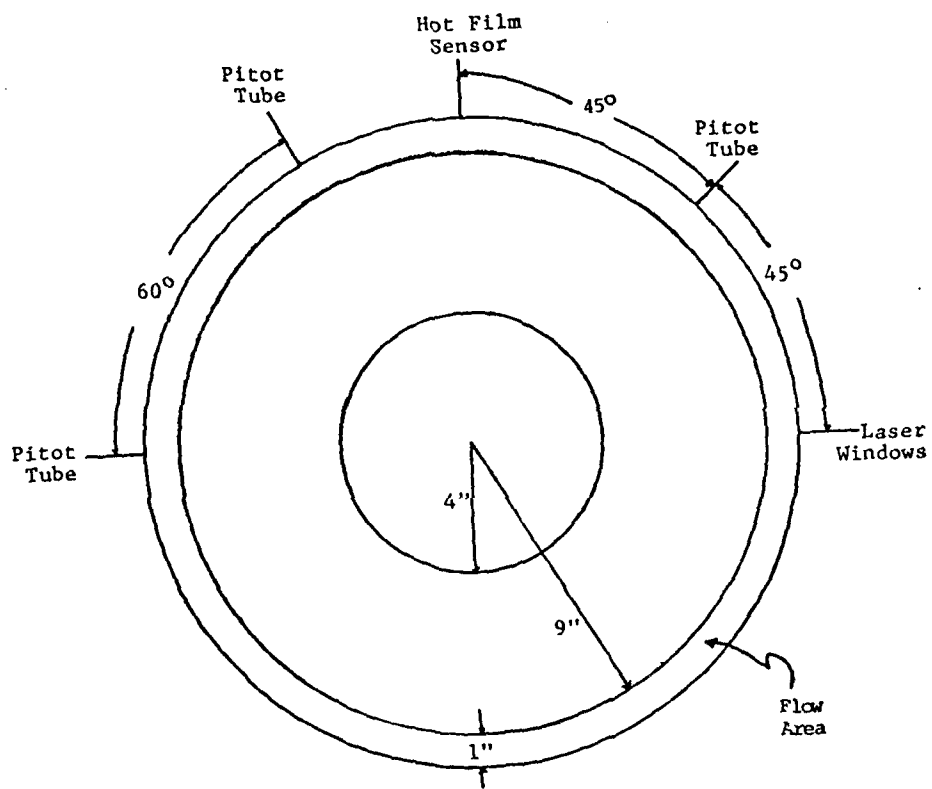

Figure 8. Inlet End View and Instrumented Stations

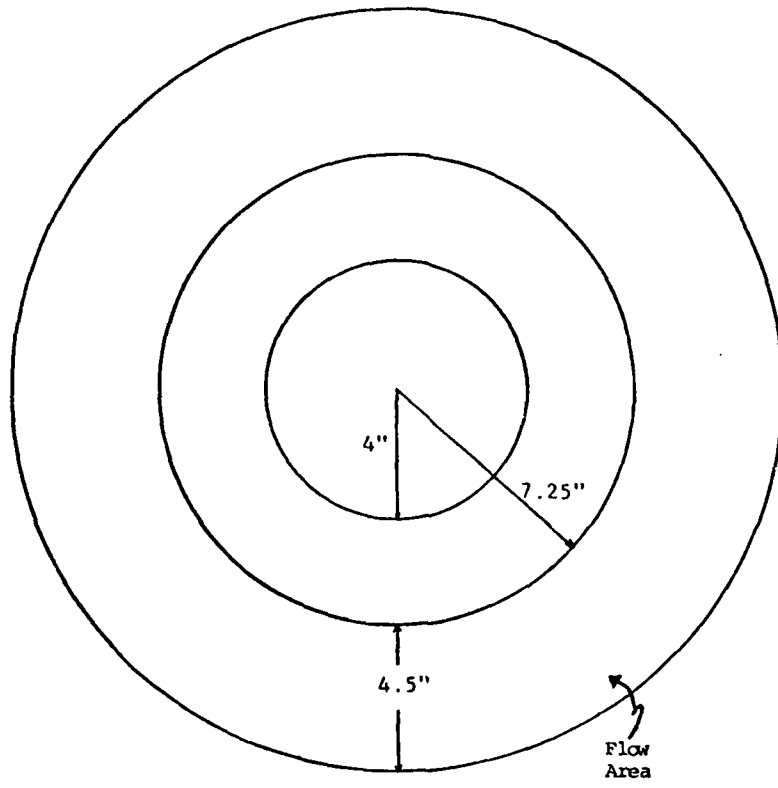

Figure 9. Exit End View

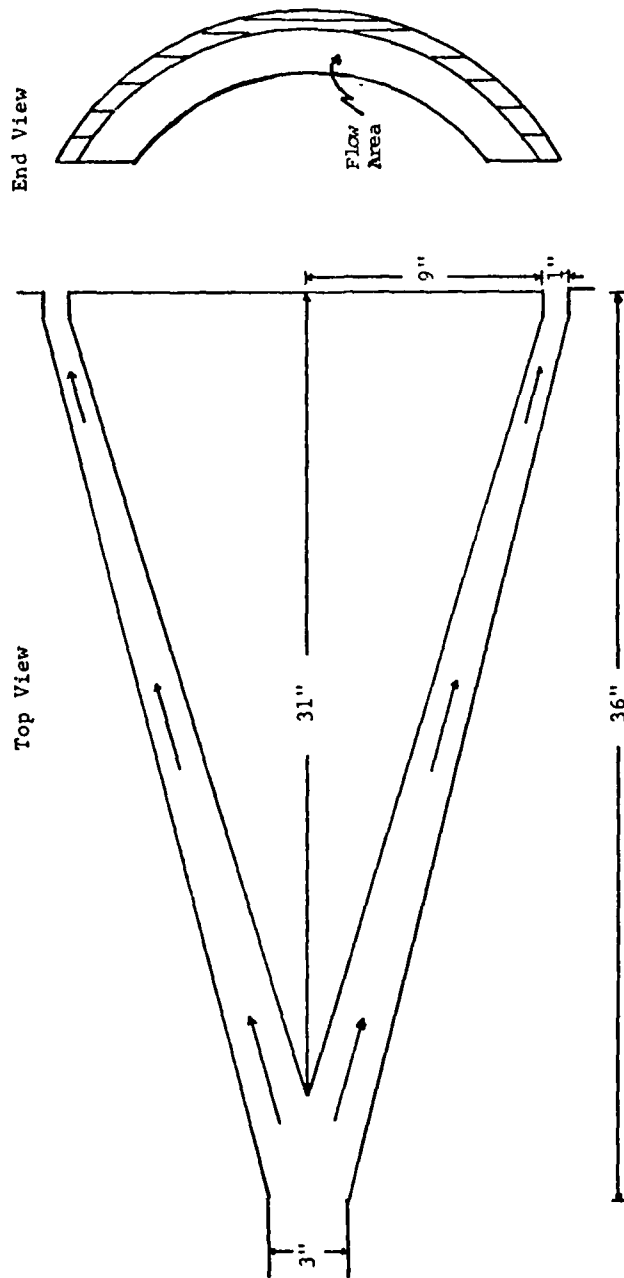

Figure 10. 120 Degree Inlet Cone

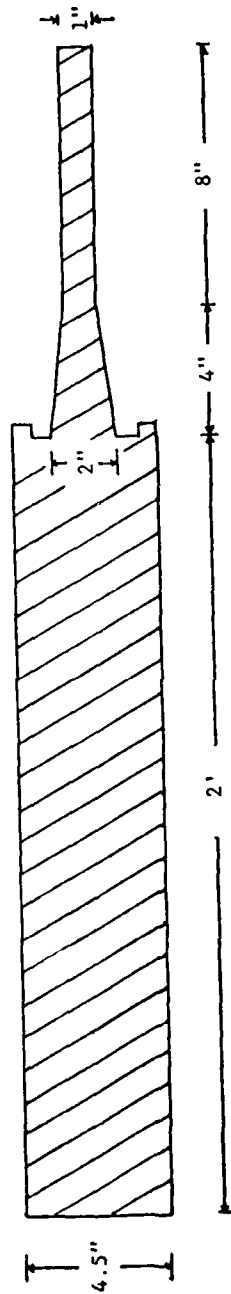

Figure 11. Diffuser Insert

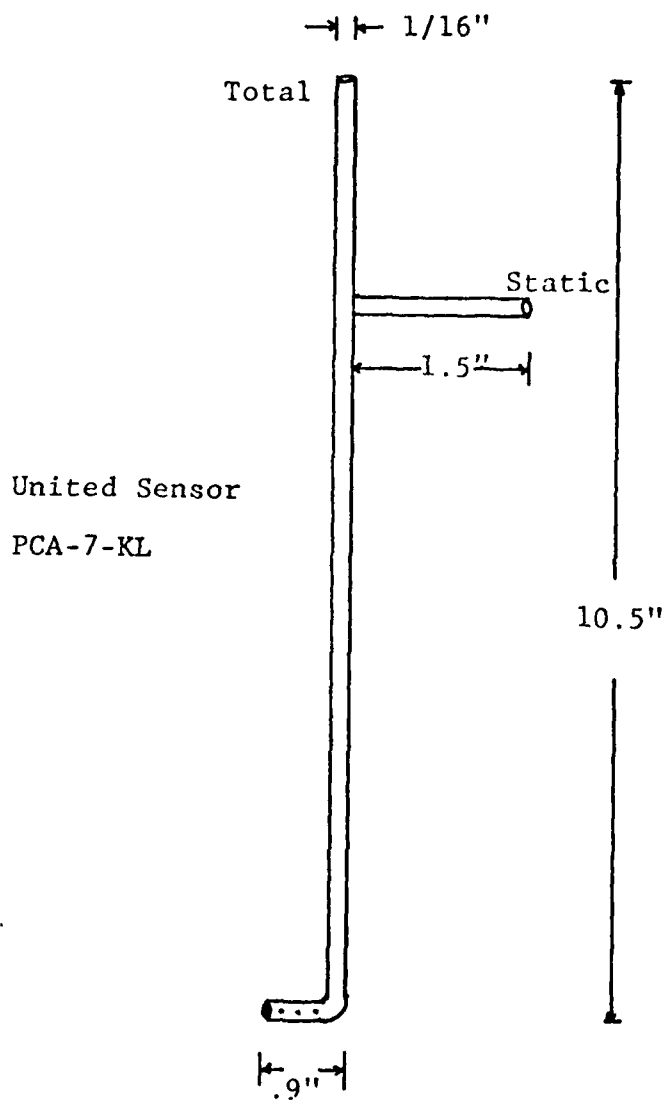

Figure 12. ASME Standard Pitot Tube

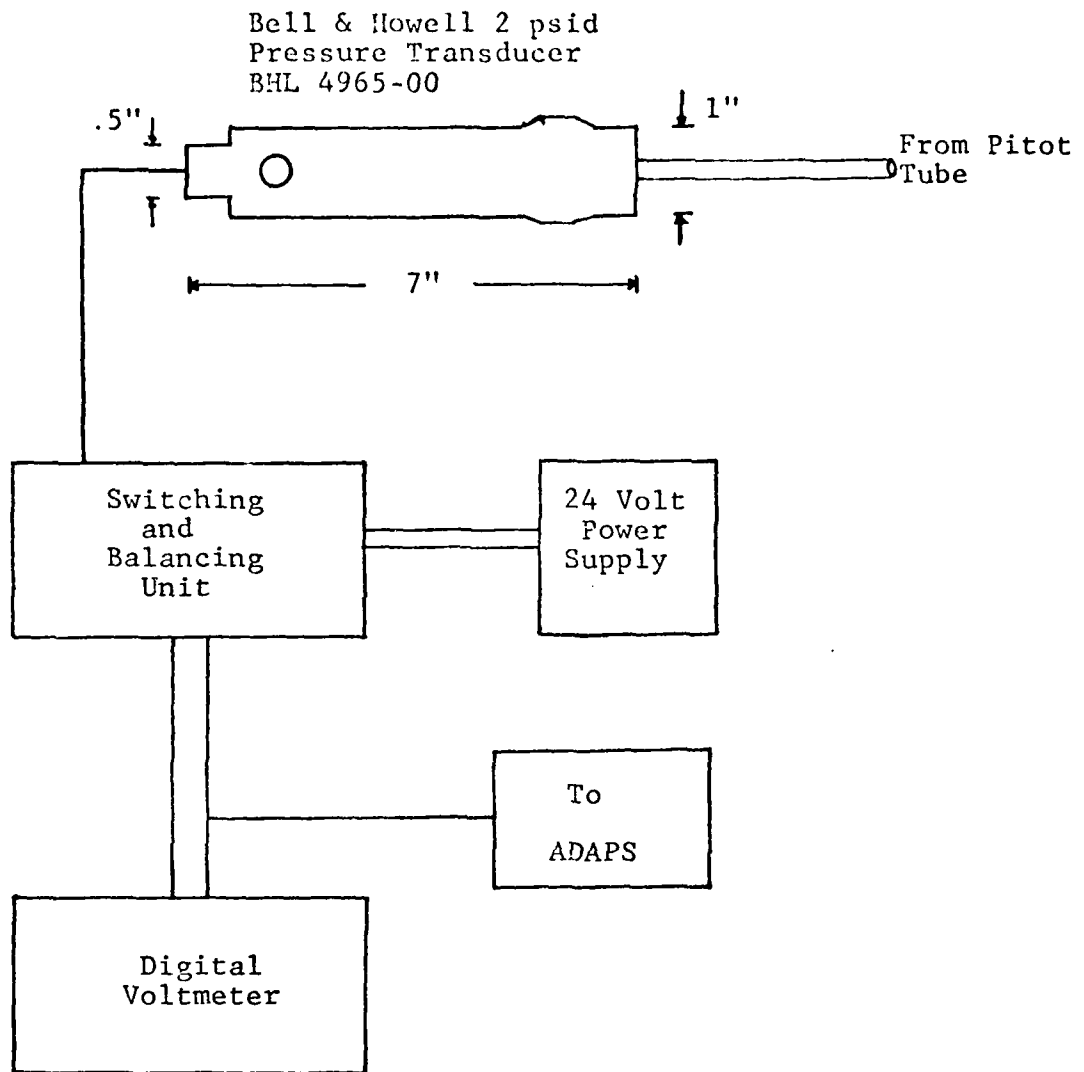

Figure 13. Pressure Transducer and Electronics

Hot Film
.0010 inches in Diameter

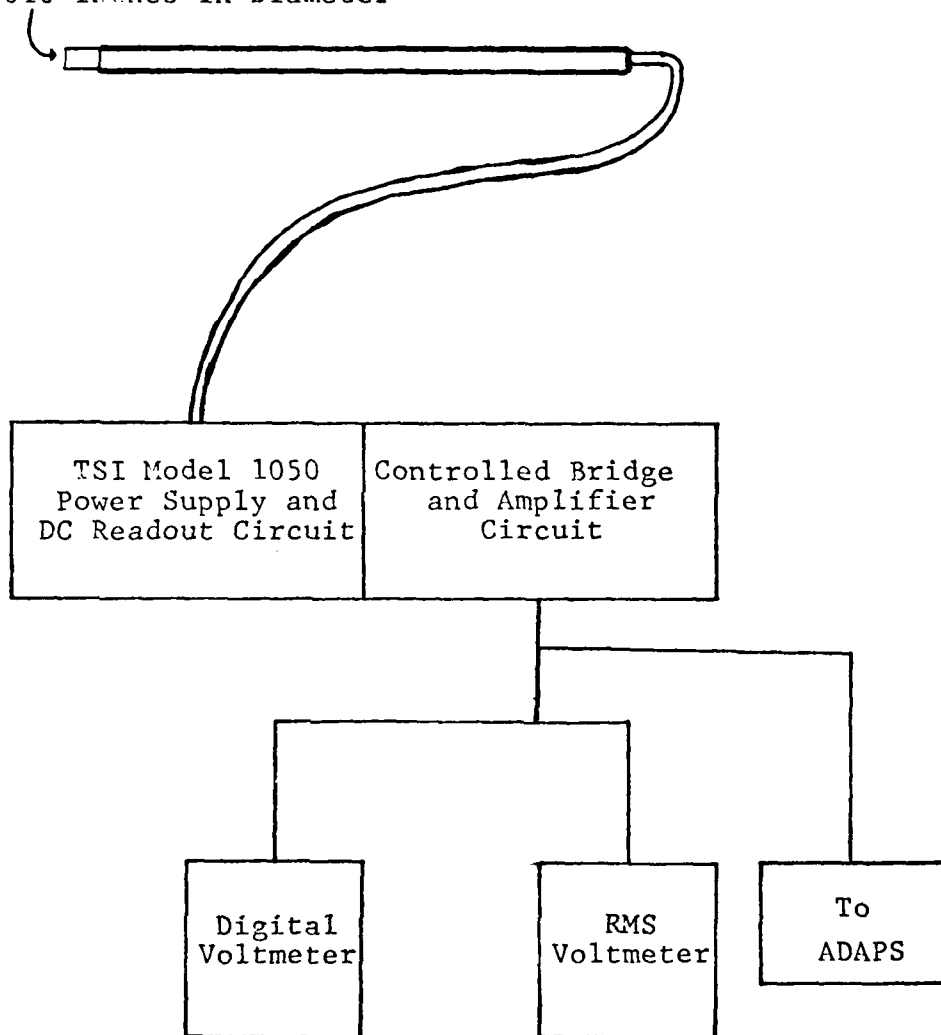
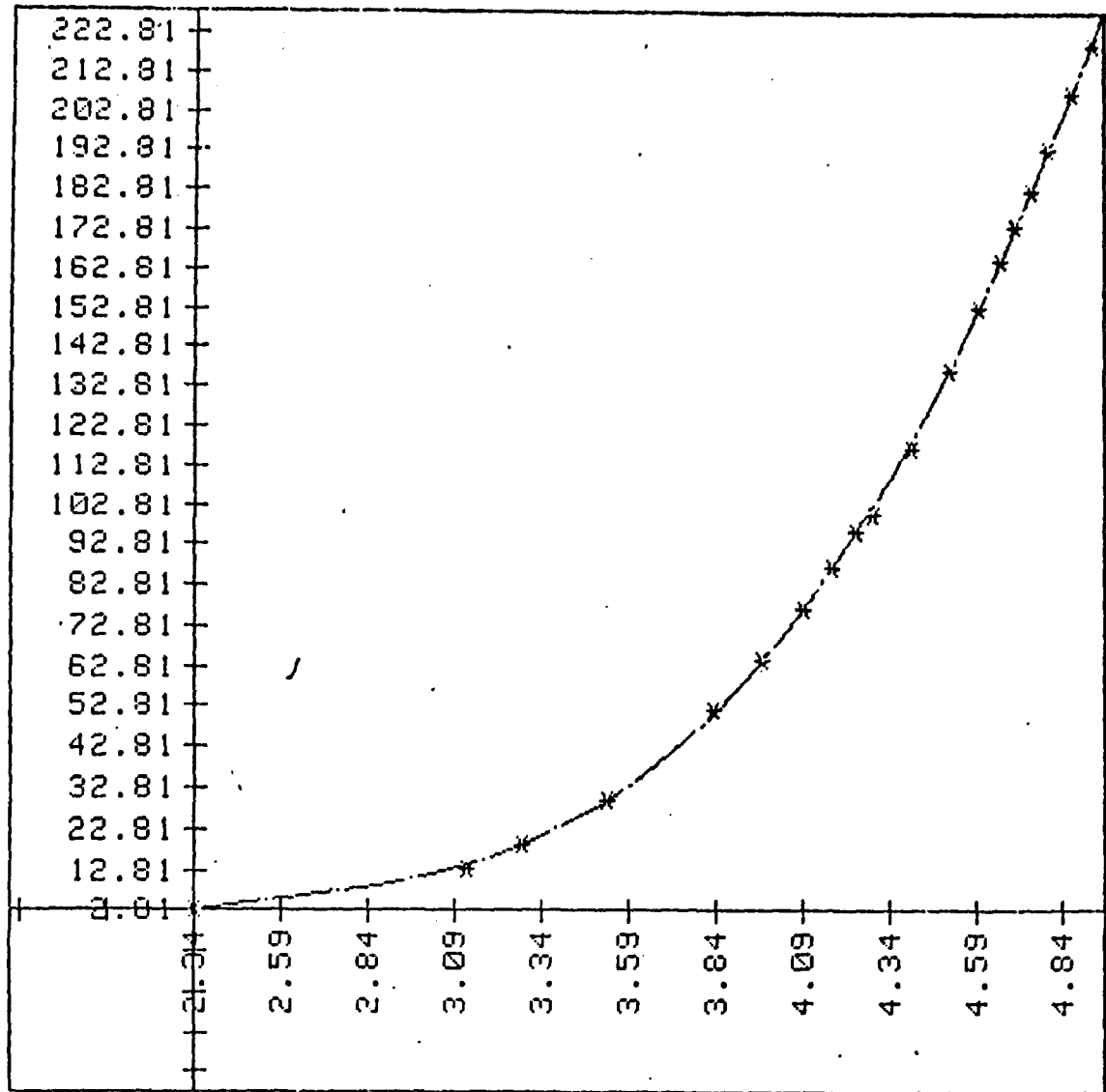

Figure 14. Hot Film Sensor and Electronics

POLYNOMIAL



FOR THE CALIBRATION CURVE:

The hotwire voltages are:

2.3378 3.1198 3.2858 3.5234 3.8338 3.9735 4.0903 4.1694 4.2382 4.2897
4.3584 4.5157 4.5987 4.6597 4.7329 4.7464 4.7987 4.8661 4.9299 4.9671

The velocities are:

2.81475078012 13.368503248 18.9852907041 30.0395236187 51.5995792703
64.4413518579 77.129042604 86.9370163033 95.9706928602 100.412775311
116.774246972 136.758789185 152.30872403 164.553132537 173.512019255
182.4570205 193.303546387 207.346180996 220.16327994 228.24358596

The equation to solve for velocity given voltage is:

$V_{ft/min} = 626.327 \cdot V^2 - 206.113 \cdot V + 43.3725 \cdot V^3 - 2.35194 \cdot V^4$

Figure 15. Hot Film Sensor Calibration

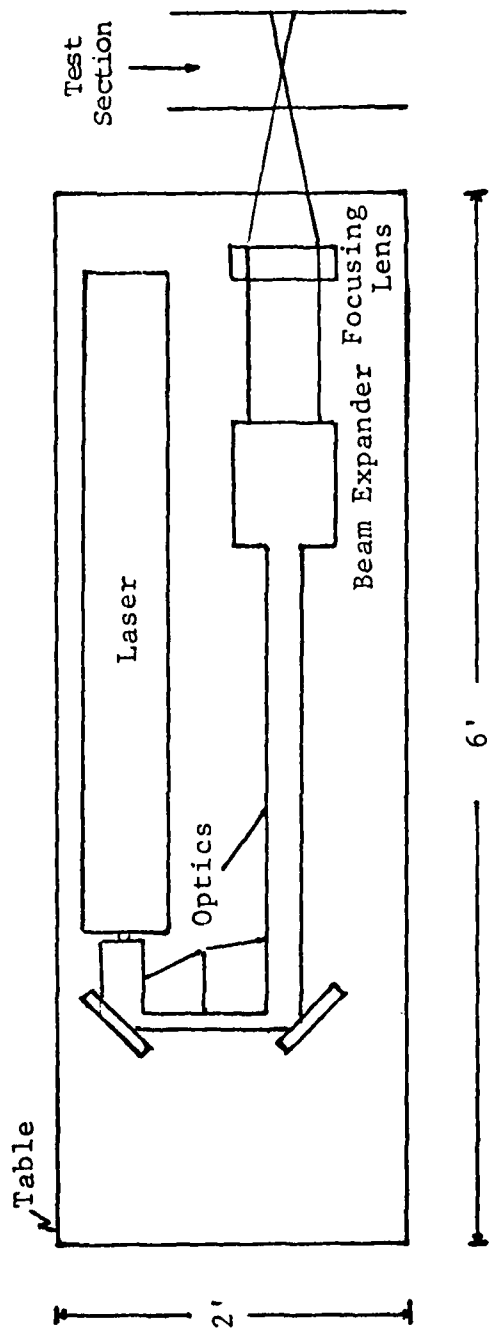
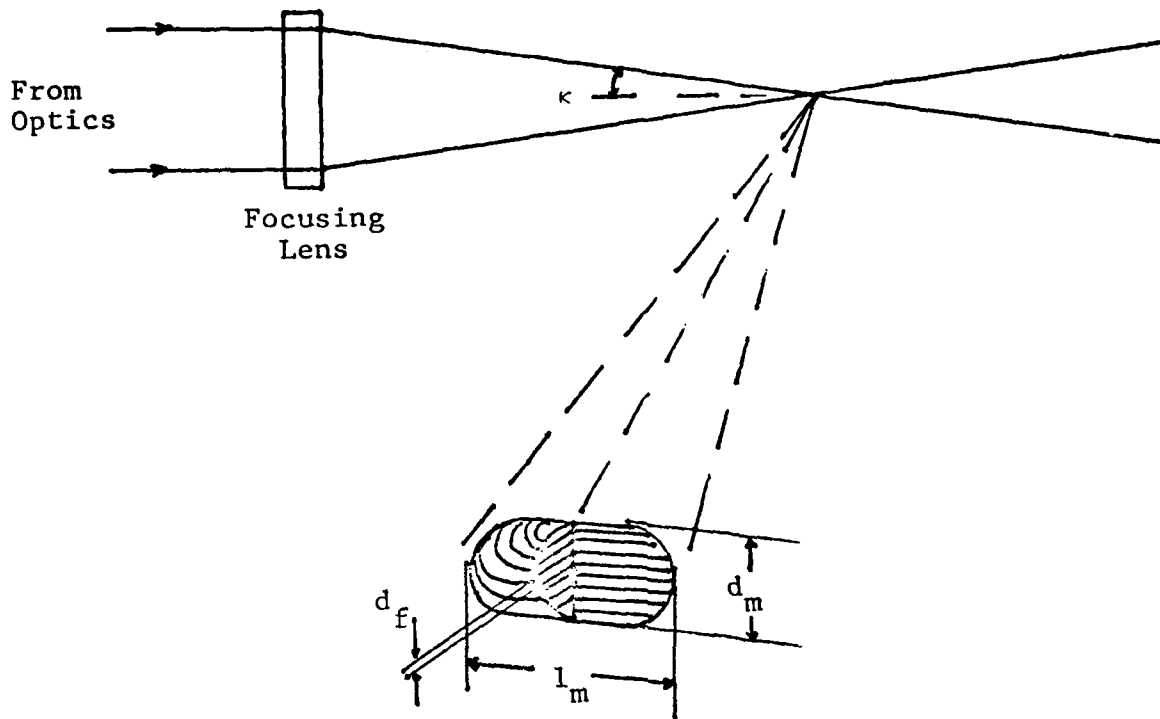

Figure 16. Laser, Optics and Platform



$$l_m = 0.61 \text{ mm}$$

$$d_f = 1.79 \text{ } \mu\text{m}$$

Figure 17. Control Volume for Laser

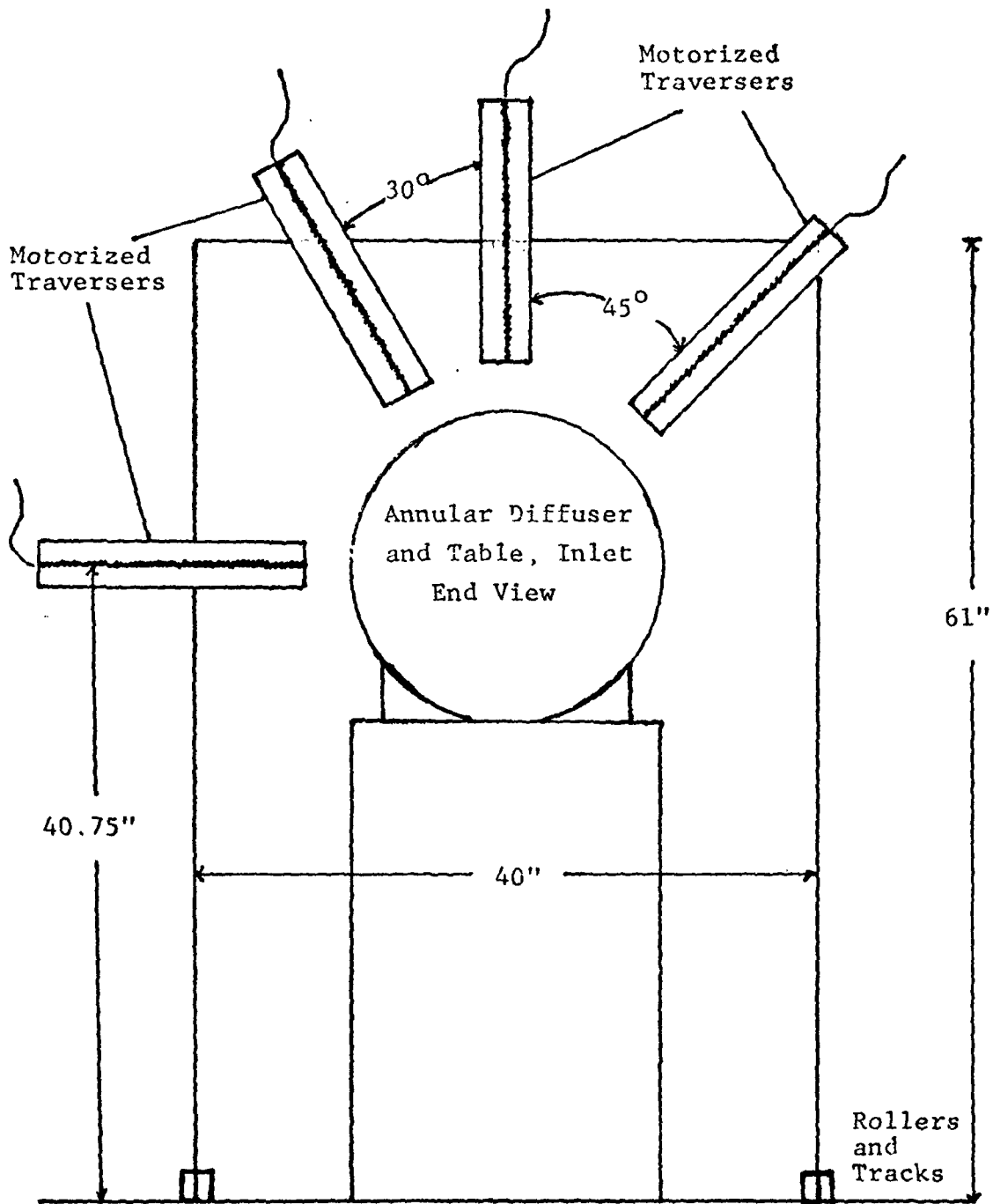

Figure 18. Traversing Mechanism

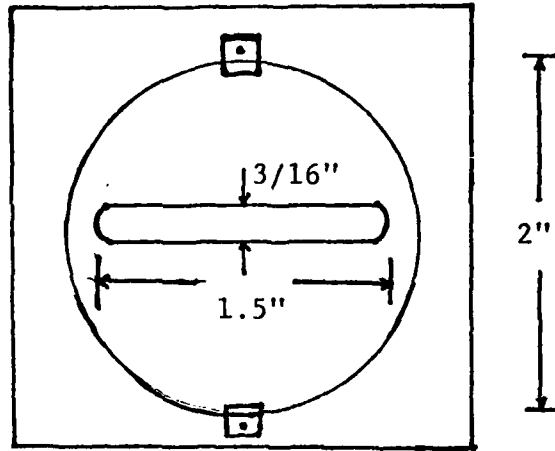

Figure 19. Holder, Laser Window and Slot

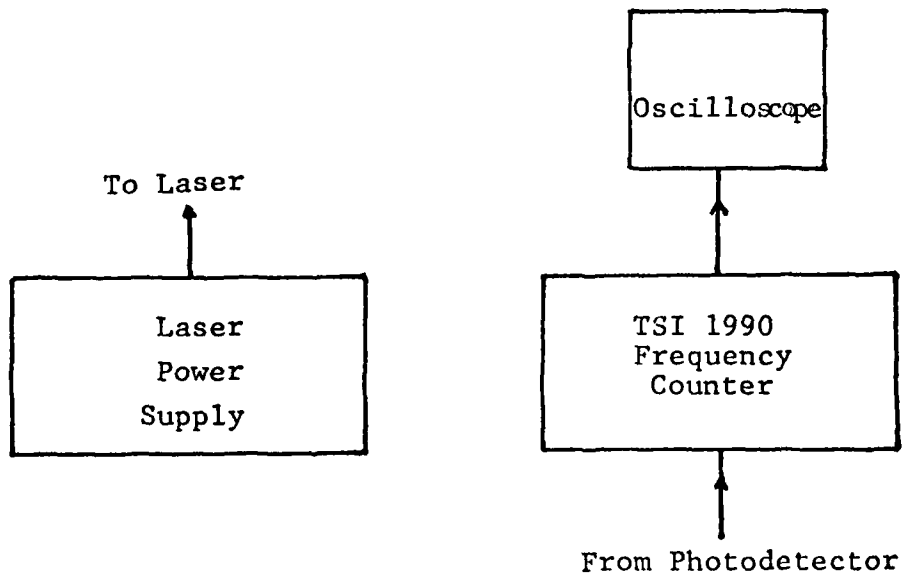

Figure 20. LDV System Electronics

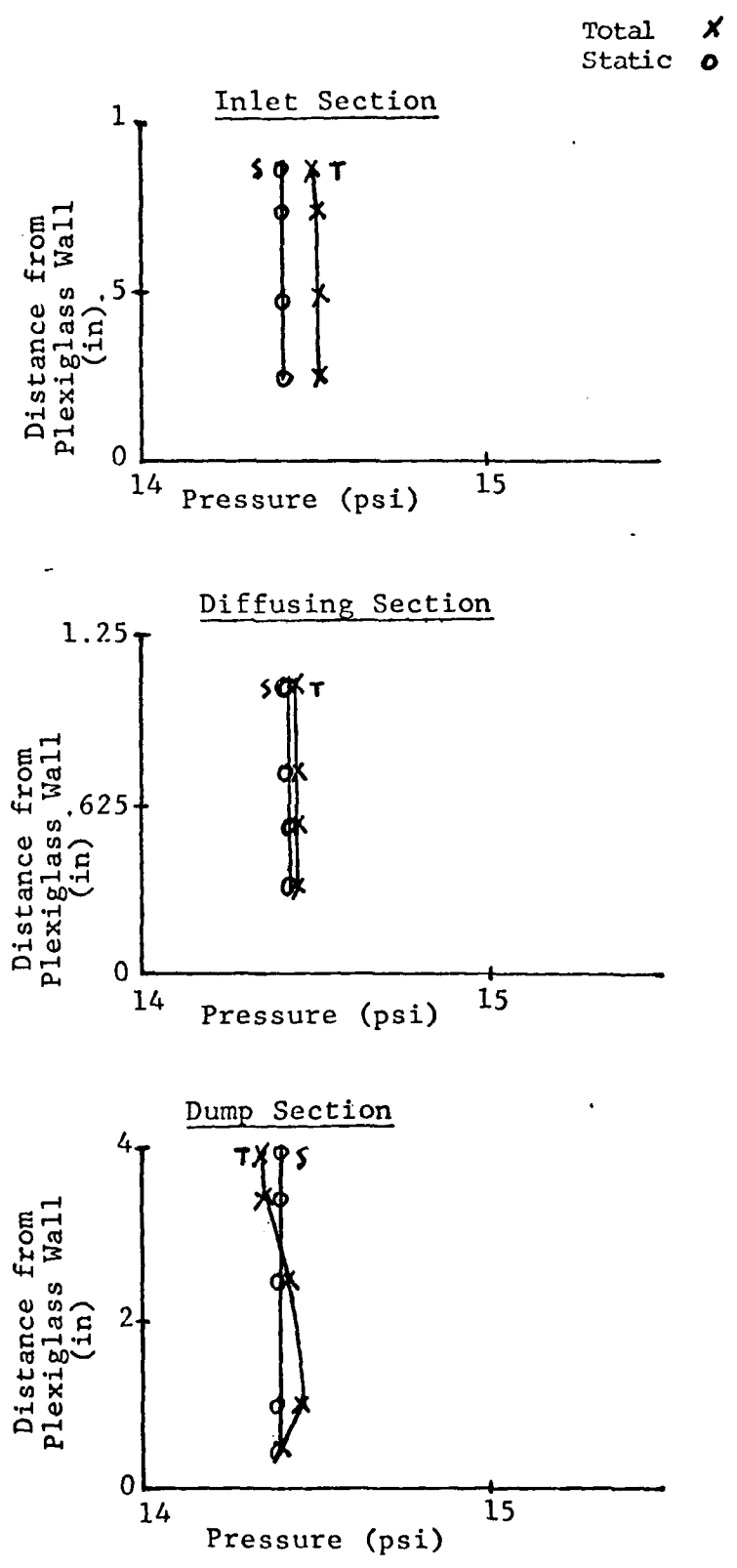

Figure 21. Radial Pressure Profiles for the Pitot Tube with Pressure Transducers

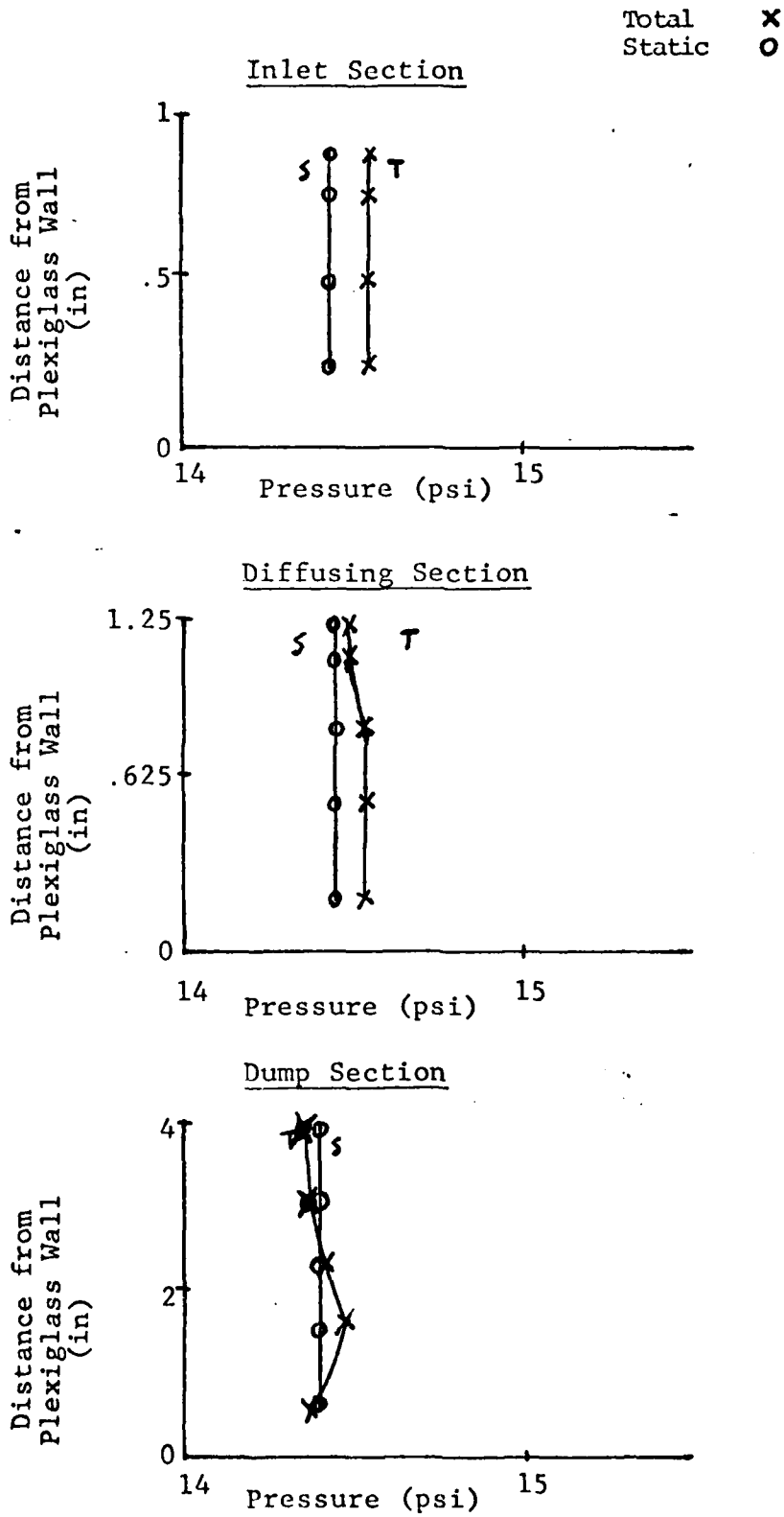

Figure 22. Radial Pressure Profiles for the Pitot Tube with Water Manometer

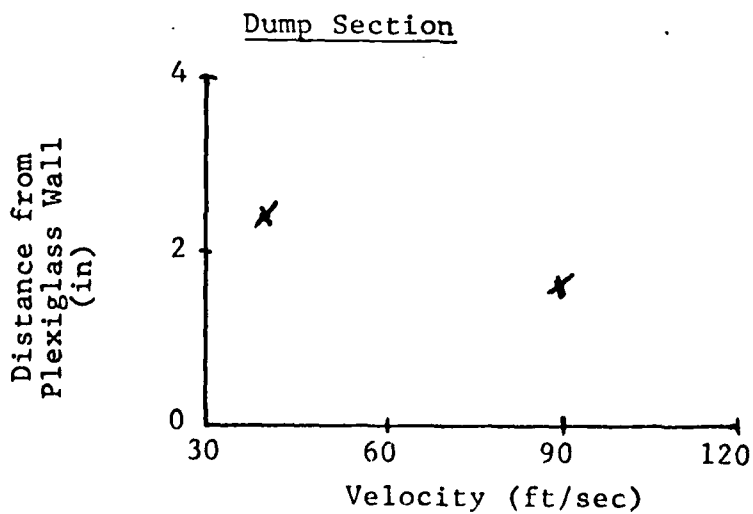
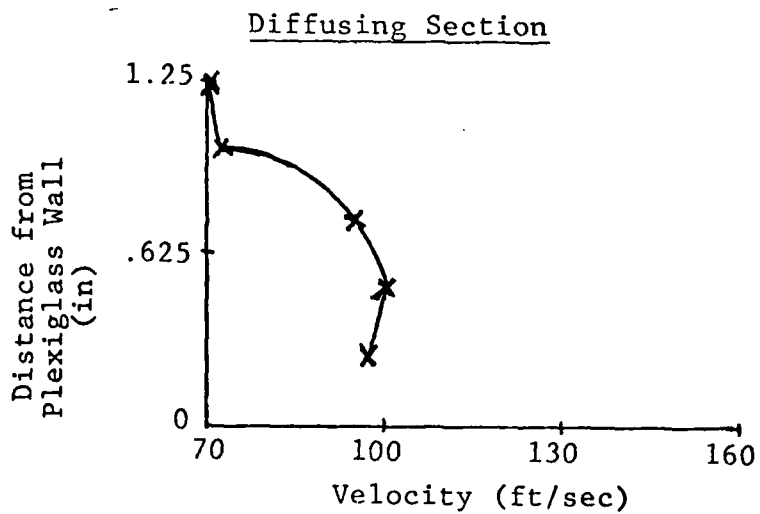
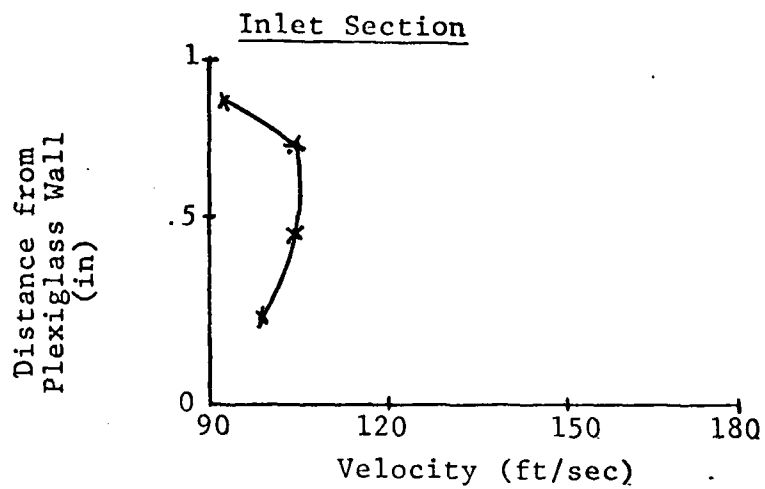

Figure 23. Radial Velocity Profiles for the Pitot Tube with Pressure Transducers

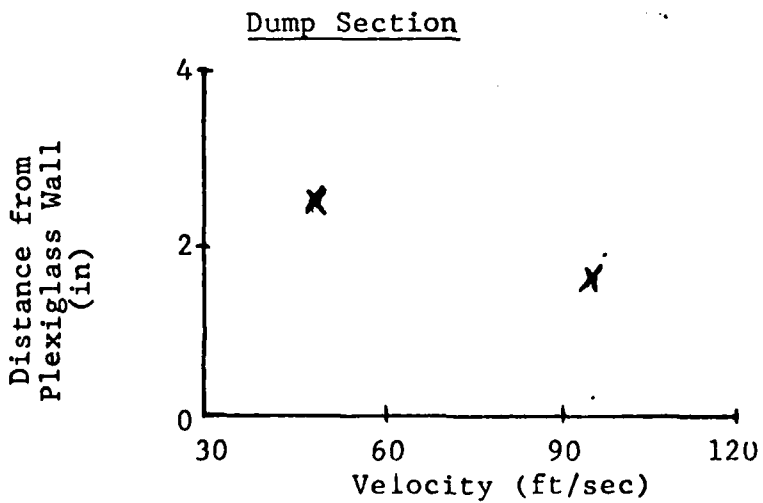
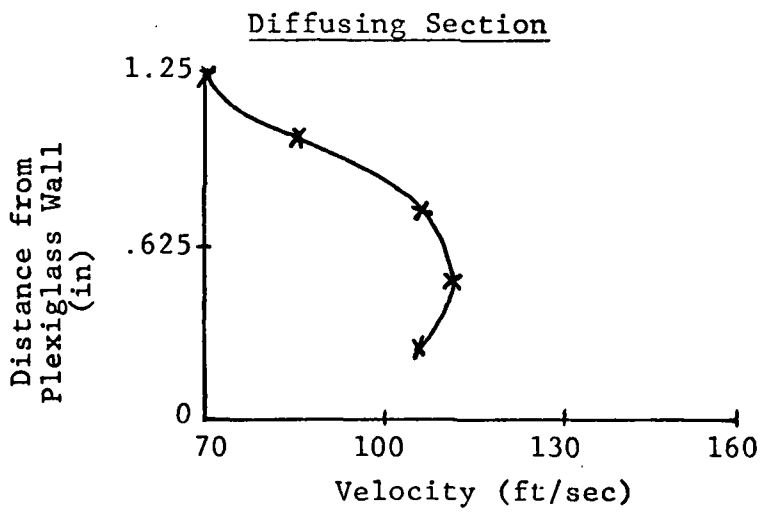
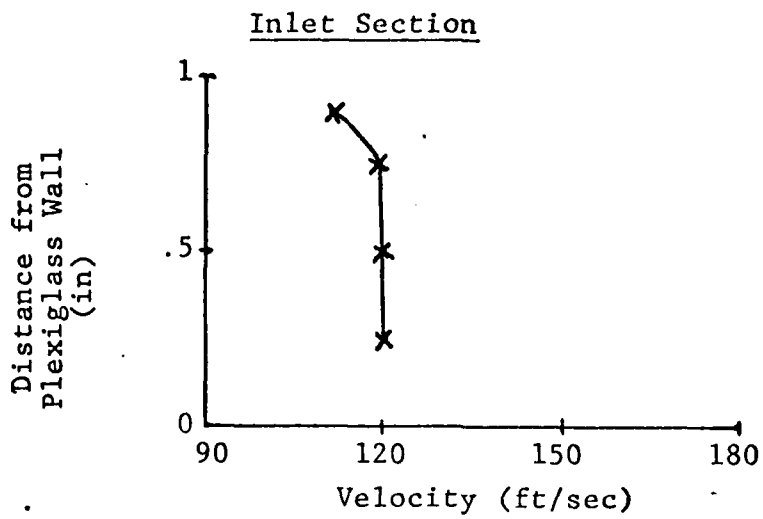

Figure 24. Radial Velocity Profiles for the Pitot Tube with Water Manometer

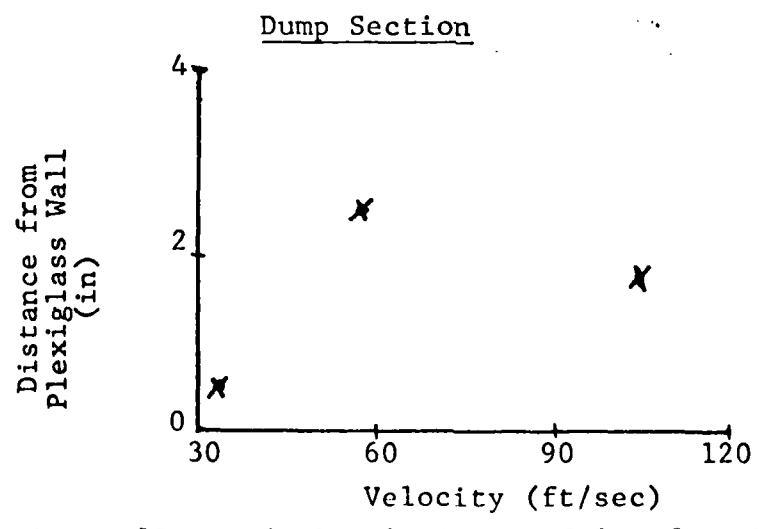
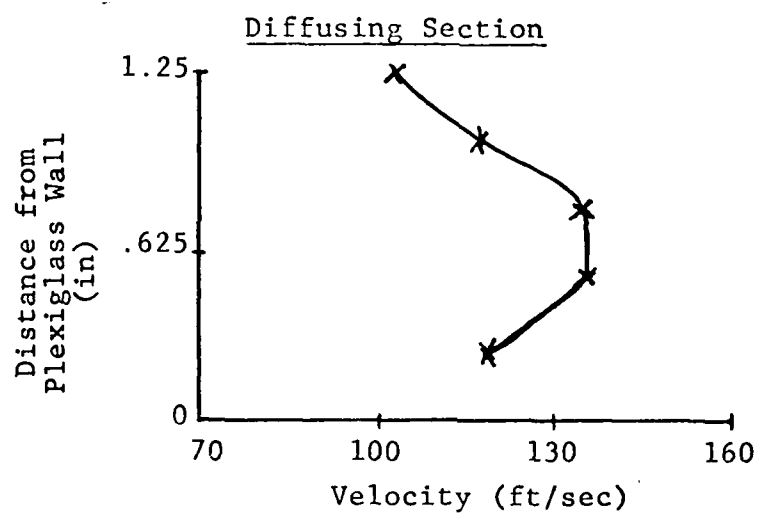
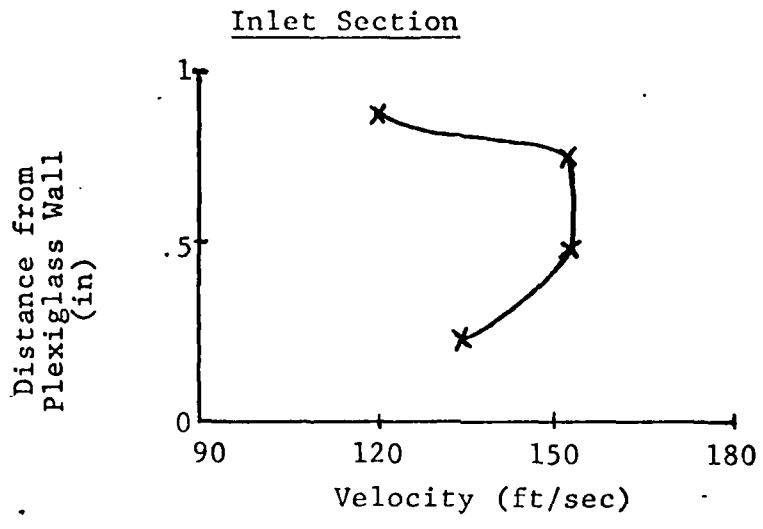

Figure 25. Radial Velocity Profiles for the Hot Film Sensor

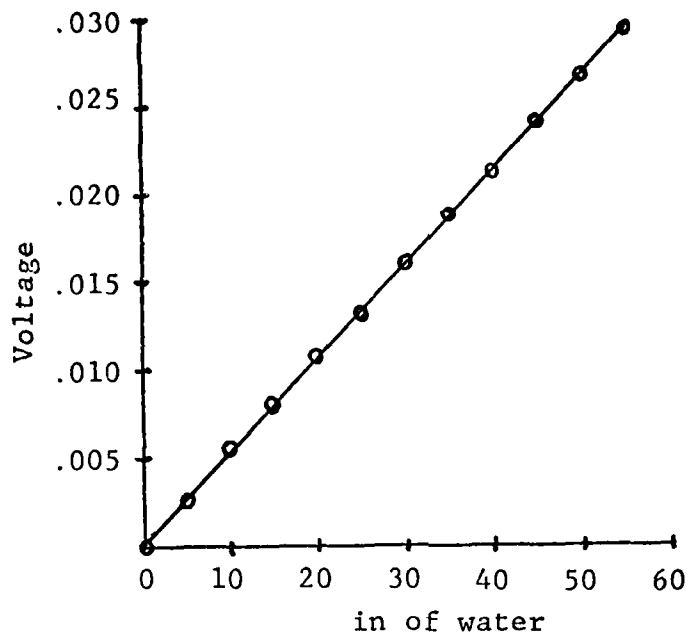

Figure 26. Pressure Transducer Calibration Curve - Bell & Howell ± 2 psid
S.N. L160401

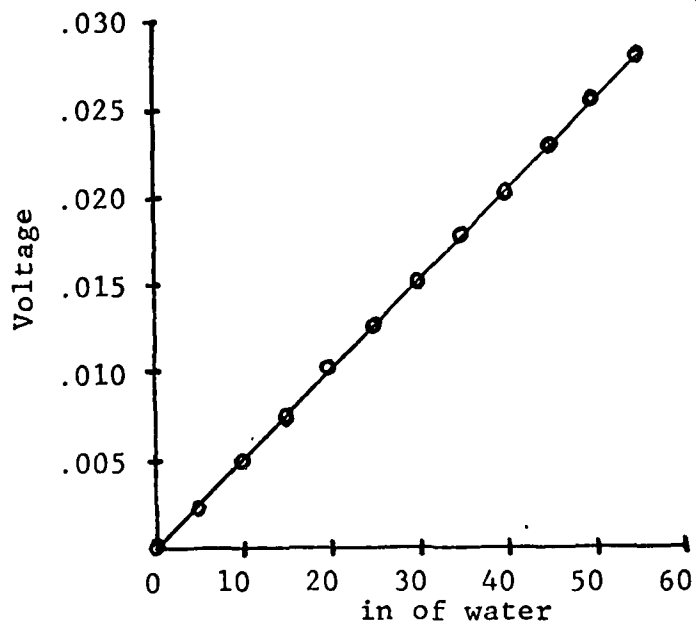

Figure 27. Pressure Transducer Calibration Curve - Bell & Howell ± 2 psid
S.N. L160407

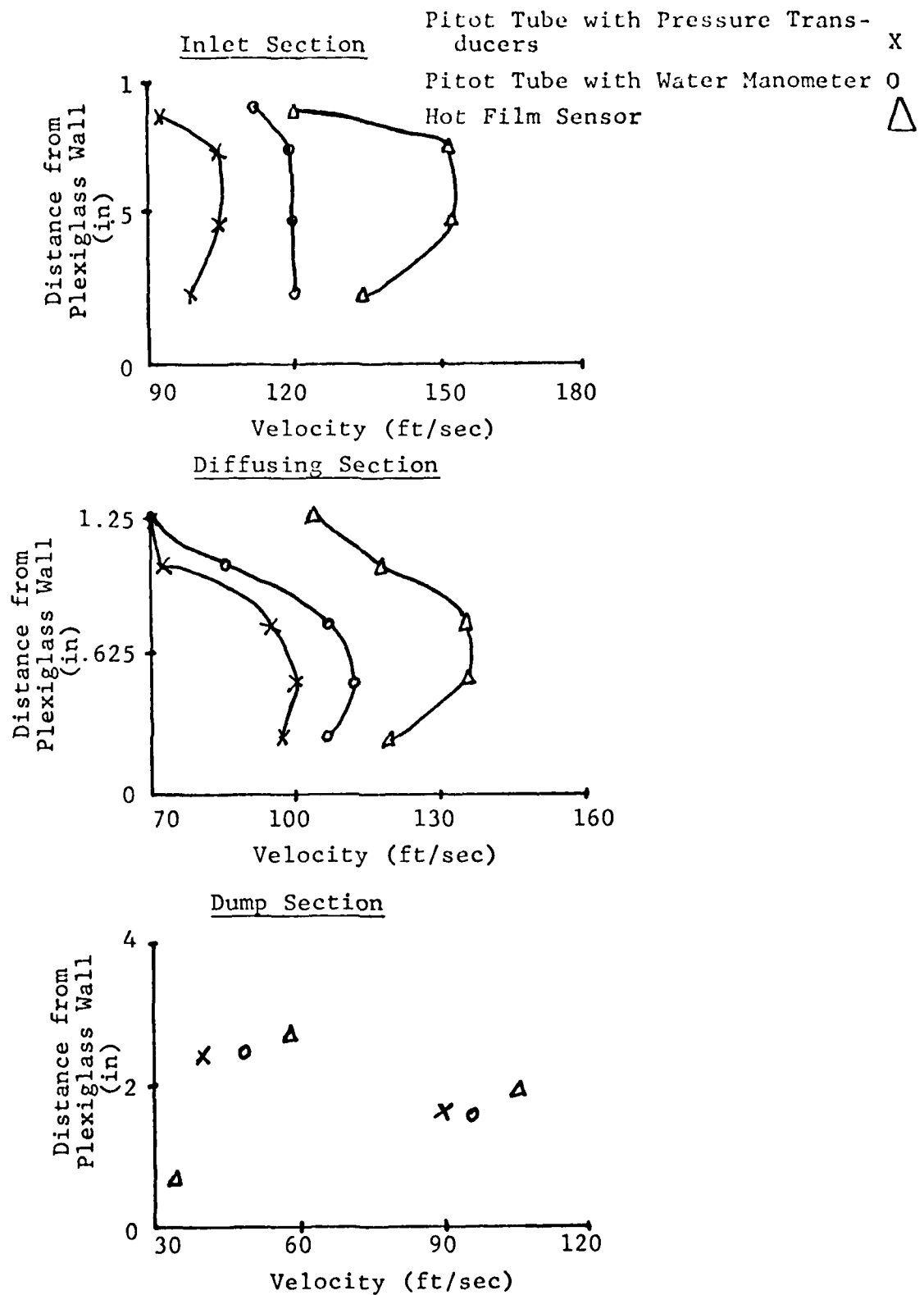

Figure 28. Hot Film Sensor and Pitot Tube Velocity Data

Appendix B

Tables

Tables

Table 1

Geometrical Relationships for Flat, Conical
and Annular Diffusers

| <u>Flat</u> | <u>Conical</u> | <u>Annular</u> |
|------------------|------------------|-------------------------------------|
| 2θ | 2θ | 2θ |
| L/W ₁ | L/R ₁ | L/(R ₁ +B ₁) |

Table II

Design of the Annular Diffuser: Inlet Conditions

Ta = 538°R

Pa = 14.24 psi

| <u>M_{inlet}</u> | <u>T_t (°R)</u> | <u>P_t (psi)</u> | <u>a (ft/sec)</u> | <u>V (ft/sec)</u> | <u>m (lbm/sec)</u> |
|--------------------------|---------------------------|----------------------------|-------------------|-------------------|--------------------|
| .2 | 542 | 14.64 | 1143 | 229 | 6.75 |
| .3 | 548 | 15.16 | 1147 | 344 | 10.1 |
| .4 | 555 | 15.90 | 1155 | 462 | 13.5 |
| .5 | 565 | 16.89 | 1165 | 583 | 16.8 |
| .6 | 577 | 18.16 | 1180 | 708 | 20.2 |

Table III

Design of the Diffusing Section: Exit Velocities

| <u>M_{inlet}</u> | <u>V (ft/sec)</u> |
|--------------------------|-------------------|
| .2 | 114 |
| .3 | 171 |
| .4 | 228 |
| .5 | 284 |
| .6 | 341 |

Table IV

Design of the Diffuser Dump: Flow Velocities

| <u>M_{inlet}</u> | <u>V (ft/sec)</u> |
|--------------------------|-------------------|
| .2 | 50.7 |
| .3 | 75.8 |
| .4 | 101 |
| .5 | 126 |
| .6 | 152 |

Table V

Pitot Tube with Pressure Transducers - Data

Pa = 14.39 psi Ta = 536°R T_t = 534°R

Location (Inches from inner surface of outer plexiglass shell)

| <u>Inlet Section</u> | <u>P_s (psi)</u> | <u>P_t (psi)</u> | <u>M</u> | <u>a(ft/sec)</u> | <u>V(ft/sec)</u> |
|--------------------------|----------------------------|----------------------------|----------|------------------|------------------|
| .25 | 14.42 | 14.50 | .088 | 1132 | 100 |
| .50 | 14.42 | 14.51 | .093 | 1132 | 105 |
| .75 | 14.42 | 14.51 | .093 | 1132 | 105 |
| .875 | 14.42 | 14.49 | .082 | 1132 | 93 |
| <u>Diffusing Section</u> | | | | | |
| .25 | 14.43 | 14.50 | .086 | 1132 | 97.4 |
| .50 | 14.43 | 14.51 | .089 | 1132 | 101 |
| .75 | 14.43 | 14.50 | .084 | 1132 | 95.1 |
| 1.00 | 14.43 | 14.58 | .065 | 1132 | 73.6 |
| 1.25 | 14.44 | 14.45 | .027 | 1132 | 30.6 |
| <u>Dump Section</u> | | | | | |
| .50 | 14.41 | 14.37 | - | 1132 | - |
| 1.50 | 14.40 | 14.47 | .080 | 1132 | 90.6 |
| 2.50 | 14.40 | 14.42 | .035 | 1132 | 39.6 |
| 3.50 | 14.40 | 14.38 | - | 1132 | - |
| 4.00 | 14.40 | 14.38 | - | 1132 | - |

Table VI

Pitot Tube with Water Manometer - Data

$P_a = 14.39 \text{ psi}$ $T_a = 536^{\circ}\text{R}$ $T_t = 534^{\circ}\text{R}$

Location (Inches from inner surface of outer plexiglass shell)

| <u>Inlet Section</u> | <u>P_s (psi)</u> | <u>P_t (psi)</u> | <u>M</u> | <u>a(ft/sec)</u> | <u>V(ft/sec)</u> |
|--------------------------|----------------------------|----------------------------|----------|------------------|------------------|
| .25 | 14.43 | 14.55 | .107 | 1132 | 121 |
| .50 | 14.43 | 14.55 | .107 | 1132 | 121 |
| .75 | 14.43 | 14.54 | .105 | 1132 | 119 |
| .875 | 14.43 | 14.53 | .099 | 1132 | 112 |
| <u>Diffusing Section</u> | | | | | |
| .25 | 14.44 | 14.53 | .094 | 1132 | 106 |
| .50 | 14.44 | 14.54 | .099 | 1132 | 112 |
| .75 | 14.44 | 14.53 | .095 | 1132 | 107 |
| 1.00 | 14.45 | 14.51 | .076 | 1132 | 86 |
| 1.25 | 14.45 | 14.47 | .036 | 1132 | 40.8 |
| <u>Dump Section</u> | | | | | |
| .50 | 14.41 | 14.36 | - | 1132 | - |
| 1.50 | 14.41 | 14.48 | .085 | 1132 | 96.2 |
| 2.50 | 14.41 | 14.43 | .045 | 1132 | 51.0 |
| 3.50 | 14.41 | 14.36 | - | 1132 | - |
| 4.00 | 14.41 | 14.36 | - | 1132 | - |

Table VII

Hot Film Sensor Data

Pa = 14.39 psi

Ta = 536^oR

T_t = 538^oR

Location (Inches from inner surface of outer plexiglass shell)

| <u>Inlet Section</u> | <u>Steady State V (ft/sec)</u> | <u>Turbulent V (ft/sec)</u> | <u>Turbulence Intensity</u> |
|--------------------------|--------------------------------|-----------------------------|-----------------------------|
| .25 | 135 | 15 | .11 |
| .50 | 153 | 15 | .098 |
| .75 | 153 | 15 | .098 |
| .875 | 119 | 14 | .12 |
| <u>Diffusing Section</u> | | | |
| .25 | 119 | 15 | .13 |
| .50 | 135 | 14 | .10 |
| .75 | 135 | 14 | .10 |
| 1.00 | 119 | 14 | .098 |
| 1.25 | 104 | 14 | .13 |
| <u>Dump Section</u> | | | |
| .50 | 33.9 | 17 | .50 |
| 1.50 | 104 | 25 | .24 |
| 2.50 | 57.0 | 28 | .49 |
| 3.50 | 16.2 | 6 | .38 |
| 4.00 | 16.2 | 6 | .38 |

Table VIII

Pitot Tube and Hot Film Data at the Same Flow Conditions

Location (Inches from inner surface of outer plexiglass shell)

| <u>Pitot Section</u> | <u>Pitot Tube with Pressure Transducers V (ft/sec)</u> | <u>Pitot Tube with Water Manometer V (ft/sec)</u> | <u>Hot Film Sensor V (ft/sec)</u> |
|--------------------------|--|---|---------------------------------------|
| .25 | 100 | 121 | 135 |
| .50 | 105 | 121 | 153 |
| .75 | 105 | 119 | 153 |
| .875 | 93 | 112 | 119 |
| <u>Diffusing Section</u> | | | |
| .25 | 97.4 | 106 | 119 |
| .50 | 101 | 112 | 135 |
| .75 | 95.1 | 107 | 135 |
| 1.00 | 73.6 | 86.0 | 119 |
| 1.25 | 30.6 | 40.8 | 104 |
| <u>Dump Section</u> | | | |
| .50 | - | - | 33.9 |
| 1.50 | 90.6 | 96.2 | 104 |
| 2.50 | 39.6 | 51.0 | 57 |
| 3.50 | - | - | 16.2 |
| 4.00 | - | - | 16.2 |

Table IX

Pressure Transducer Calibration Data

Bell & Howell + 2psid S.N. L160401 +10V Excitation

| <u>psi</u> | <u>in of water</u> | <u>voltage</u> |
|------------|--------------------|----------------|
| 0 | 0 | -.0000 |
| .1806 | 5 | +.0026 |
| .3613 | 10 | .0055 |
| .5419 | 15 | .0081 |
| .7225 | 20 | .0107 |
| .9032 | 25 | .0133 |
| 1.084 | 30 | .0160 |
| 1.265 | 35 | .0186 |
| 1.445 | 40 | .0212 |
| 1.626 | 45 | .0240 |
| 1.806 | 50 | .0266 |
| 1.987 | 55 | .0293 |

Table X
Pressure Transducer Calibration Data

| Bell & Howell <u>±</u> 2psid | S.N, L160407 | +10V Excitation |
|------------------------------|--------------------|-----------------|
| <u>psi</u> | <u>in of water</u> | <u>voltage</u> |
| 0 | 0 | -.0001 |
| .1806 | 5 | .0023 |
| .3613 | 10 | .0051 |
| .5419 | 15 | .0075 |
| .7225 | 20 | .0101 |
| .9032 | 25 | .0126 |
| 1.084 | 30 | .0152 |
| 1.265 | 35 | .0177 |
| 1.445 | 40 | .0203 |
| 1.626 | 45 | .0228 |
| 1.806 | 50 | .0254 |
| 1.987 | 55 | .0280 |

Appendix C

Hot Film Turbulent Velocity Calculations

The method used to find the turbulent component of the velocity from hot film data is found in the Ph.D. Dissertation "Turbulence and the Mixing of Binary Gas" by S. Zakanycz. This was performed at the Ohio State University in 1971.

Begin with the fourth degree polynomial used to determine steady state velocities.

$$\text{Velocity} = A + B (\text{Volts}) + C (\text{Volts})^2 + D (\text{Volts})^3 + E (\text{Volts})^4$$

Differentiate the above equation.

$$d (\text{Velocity}) = B + 2C (\text{Volts}) + 3D (\text{Volts})^2 + 4E (\text{Volts})^3$$

Now enter the DC component of the measured voltage into this equation. The resulting $d (\text{Velocity})$ value is then multiplied by the AC component of the measured voltage. This number is the fluctuating component of the velocity.

| REPORT DOCUMENTATION PAGE | | READ INSTRUCTIONS BEFORE COMPLETING FORM |
|---|------------------------------------|---|
| 1. REPORT NUMBER AFIT/GAE/AA/81D-16 | 2. GOVT ACCESSION NO. DD 411 /c | 3. RECIPIENT'S CATALOG NUMBER 2 |
| 4. TITLE (and Subtitle) Design Fabrication and Testing of an Axisymmetric, Annular Subsonic Diffuser and Associated Instrumentation Systems | | 5. TYPE OF REPORT & PERIOD COVERED MS Thesis |
| 7. AUTHOR(s) John V. Kelley, Jr., Lieutenant, USAF | | 6. PERFORMING ORG. REPORT NUMBER |
| 9. PERFORMING ORGANIZATION NAME AND ADDRESS Air Force Institute of Technology (AFIT/EN) Wright-Patterson Air Force Base, Ohio 45433 | | 8. CONTRACT OR GRANT NUMBER(s) |
| 11. CONTROLLING OFFICE NAME AND ADDRESS | | 10. PROGRAM ELEMENT, PROJECT, TASK AREA & WORK UNIT NUMBERS 62203F, 3066, 05 |
| 14. MONITORING AGENCY NAME & ADDRESS (if different from Controlling Office) | | 12. REPORT DATE December 1981 |
| | | 13. NUMBER OF PAGES 80 |
| | | 15. SECURITY CLASS. (of this report) UNCLASSIFIED |
| | | 15a. DECLASSIFICATION/DOWNGRADING SCHEDULE |
| 16. DISTRIBUTION STATEMENT (of this Report) Approved for public release; distribution unlimited. | | |
| 17. DISTRIBUTION STATEMENT (of the abstract entered in Block 20, if different from Report) APPROVED FOR PUBLIC RELEASE MAR 1984 | | |
| 18. SUPPLEMENTARY NOTES 28 JAN 1982 Chronic S. Lynch AFIT/EN 62203F | | |
| 19. KEY WORDS (Continue on reverse side if necessary and identify by block number) Annular Diffuser Turbulence Laser Doppler Velocimeter (LDV) Air Force Institute of Technology (AFIT) Wright-Patterson AFB, OH 45433 | | |
| 20. ABSTRACT (Continue on reverse side if necessary and identify by block number) Aerodynamic parametric data of annular diffuser flow field for gas turbine engines are not available in sufficient detail. They are badly needed for future high efficiency engine design. A subsonic, axisymmetric, annular diffuser model was designed for the purpose of making such highly detailed information available. The objective of the design was to approximate an actual gas turbine engine diffuser. The diffuser was built according to these design specifications. | | |

The instrumentation required to gather the necessary pressure, velocity, and turbulence parameters consisted of three pitot tube systems, a hot wire anemometer system and a laser doppler velocimeter (LDV) system using frequency counting. These three instrumentation systems were integrated into the diffuser to obtain data at each of three points along the longitudinal axis. At each point there were five stations along the annulus that were instrumented. A longitudinal traversing structure utilizing motorized traversers for radial positioning and the capability to integrate absolute encoders was used to access the flow area.

The three instrumentation systems have the capability to be integrated into a Hewlett Packard 9845/B computer-controller for data acquisition and processing. The experimental apparatus, data acquisition and processing, and flow traversing were integrated and functional, as demonstrated by the preliminary data.

UNCLASSIFIED