

AD-A111 469

ARINC RESEARCH CORP ANNAPOLIS MD F/O 1/8
IMPROVEMENT PROGRAM FOR THE C-141 NAVIGATION SELECTOR PANEL. (U)
JAN 82 H L RISER F09603-80-0-3530-0012
2315-11-1-2635 NL

UNCLASSIFIED

low
res



END
DATE
FILMED
DTIC

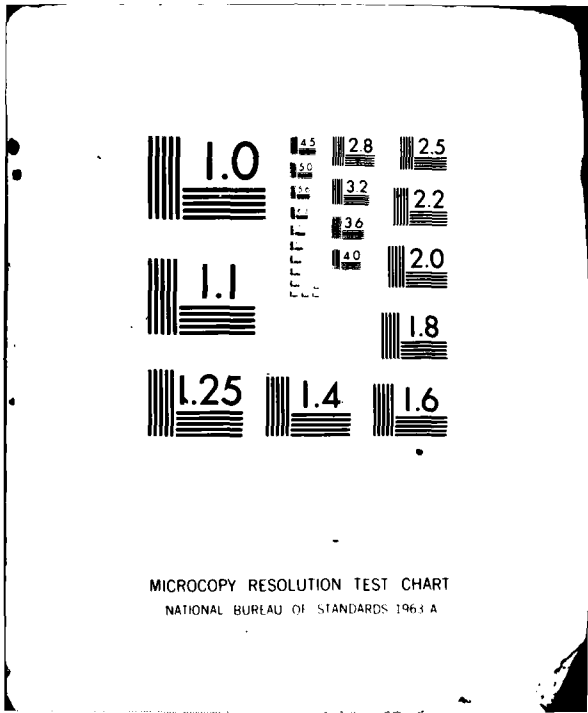

MICROCOPY RESOLUTION TEST CHART
NATIONAL BUREAU OF STANDARDS-1963-A

AD A111469



**FINAL ENGINEERING REPORT
IMPROVEMENT PROGRAM FOR THE
C-141 NAVIGATION SELECTOR PANEL**

January 1982

**Prepared for
RELIABILITY ENGINEERING BRANCH
ITEM MANAGEMENT DIVISION
MMIRCA-4
ROBINS AIR FORCE BASE, GEORGIA 31098
under Contract F09603-80-G-3338-0012**

Handwritten markings including the number '2' and other illegible scribbles.

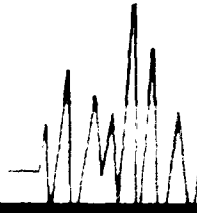

ARINC RESEARCH CORPORATION

APPROVED BY: _____
DATE: _____
INITIALS: _____

FINAL ENGINEERING REPORT

IMPROVEMENT PROGRAM FOR THE
C-141 NAVIGATION SELECTOR PANEL

January 1982

by

Henry L. Riser, Jr.

The investigation reported in this document was requested by the Reliability Engineering Branch, Item Management Division, MMIRCA-4, of Warner Robins Air Logistics Center, WR-ALC, Robins Air Force Base, Georgia, 31098, under Government Contract Number F09603-80-G-3338-0012. However, it does not necessarily bear the endorsement of the requesting agency.

ARINC Research Corporation
a Subsidiary of Aeronautical Radio, Inc.
2551 Riva Road
Annapolis, Maryland 21401
Publication 2315-11-1-2635

Unclassified

SECURITY CLASSIFICATION OF THIS PAGE (When Data Entered)

REPORT DOCUMENTATION PAGE		READ INSTRUCTIONS BEFORE COMPLETING FORM
1. REPORT NUMBER 2315-11-1-2635	2. GOVT ACCESSION NO. ADALL 469	3. RECIPIENT'S CATALOG NUMBER
4. TITLE (and Subtitle) Improvement program for the C-141 navigation selector panel		5. TYPE OF REPORT & PERIOD COVERED
		6. PERFORMING ORG. REPORT NUMBER 2315-11-1-2635
7. AUTHOR(s) Henry L. Riser, Jr.		8. CONTRACT OR GRANT NUMBER(s) F09603-80-G-3338-0012
9. PERFORMING ORGANIZATION NAME AND ADDRESS ARINC Research Corp. 2551 Riva Road Annapolis, Md. 21401		10. PROGRAM ELEMENT, PROJECT, TASK AREA & WORK UNIT NUMBERS
11. CONTROLLING OFFICE NAME AND ADDRESS Reliability Engineering Branch, Item Management Division, MMIRCA-4, Robins AFB, Georgia 21098		12. REPORT DATE January 1982
		13. NUMBER OF PAGES 22
14. MONITORING AGENCY NAME & ADDRESS (if different from Controlling Office)		15. SECURITY CLASS. (of this report)
		15a. DECLASSIFICATION/DOWNGRADING SCHEDULE
16. DISTRIBUTION STATEMENT (of this Report) Unlimited		
17. DISTRIBUTION STATEMENT (of the abstract entered in Block 20, if different from Report)		
18. SUPPLEMENTARY NOTES		
19. KEY WORDS (Continue on reverse side if necessary and identify by block number) AIRCRAFT-C-141 NAVIGATION SELECTOR PANEL NAVIGATION EQUIPMENT		
20. ABSTRACT (Continue on reverse side if necessary and identify by block number) This report presents the results of an engineering study to improve the reliability and maintainability of the Navigation Selector Panel, Part Number 75-89181, NSN 6605-01-038-6849JH, used in all models of the C-141 aircraft. The work described in this document was performed for the U. S. Air Force and specifically for the Reliability Engineering Branch, Item Management Division, MMIRCA-4, of Robins Air Force Base, Georgia, 31098. Maintenance data covering one year were obtained and analyzed. The items most often replaced were the lighted push-button switches in the assembly caused by poor switch design. Changes were recommended.		

DD FORM 1473
1 JAN 73

EDITION OF 1 NOV 65 IS OBSOLETE

Unclassified

SECURITY CLASSIFICATION OF THIS PAGE (When Data Entered)

Copyright © 1982

ARINC Research Corporation

This material may be reproduced by or for
the U. S. Government pursuant to the copy-
right license under DAR Clause 7-104.9(a)
(May 1981).

DTIC
ELECTE
MAR 1 1982
D
H

FOREWORD

This report presents the results of an engineering study to improve the reliability and maintainability of the Navigation Selector Panel, Part Number 75-89181, NSN 6605-01-038-6849JH, used in all models of the C-141 aircraft. The work described in this document was performed for the U.S. Air Force and specifically for the Reliability Engineering Branch, Item Management Division, MMIRCA-4, of Warner Robins Air Logistics Center, Robins Air Force Base, Georgia 31098, under Contract Number F09603-80-G-3338-0012.

The author was assisted in the work performed in this project by Mr. John Alcott of ARINC Research Corporation. Technical direction was provided by Mr. David Orr and Mr. James Rowland of Warner Robins Air Logistics Center. Assistance in testing was provided by Mr. James Tye, also of Warner Robins Air Logistics Center, and Mr. Robert Waters and base maintenance office personnel at McGuire AFB, New Jersey.

Accession For	
NTIS GRA&I	<input checked="" type="checkbox"/>
DTIC TAB	<input type="checkbox"/>
Unannounced	<input type="checkbox"/>
Justification	
By	
Distribution	
Availability Codes	
Dist	
A	

ABSTRACT

This report presents the results of an engineering study to improve the reliability and maintainability of the Navigation Selector Panel (NSP) for the C-141 aircraft. Maintenance data covering one year were obtained from Warner Robins Air Logistics Center (WR-ALC) and analyzed. The items most often replaced, other than lamps, were the lighted push-button switches in the assembly. We found the major cause of failure to be an inadequate switch design; the best solution was to replace the switches. We conducted a market survey, selected a military-specification-qualified switch, and ordered sufficient quantities to modify two NSPs. We designed and fabricated housing brackets and modified the edge-lit panel. The two modified NSPs were assembled and tested at McGuire AFB using the control unit tester and the test procedures outlined in T.O. 5N6-9-9-2, Intermediate Maintenance Instructions. A specification for a new switch assembly was developed. We reviewed the data package developed by Electrospace, Inc. (ESI), the prime contractor for the NSP, and made changes where necessary because of the new switch assembly. The report recommends an engineering change proposal to adopt the design for improved reliability and maintainability.

CHAPTER ONE

INTRODUCTION

1.1 BACKGROUND

The Navigation Selector Panel (NSP) for the C-141 aircraft has experienced chronic switch-assembly failures that have had an adverse effect on the availability of navigation systems. The failures are primarily of the lighted push-button switches and, to a lesser degree, the printed circuit board. Problems include sticking push buttons, shorting of internal switch contacts, and failure of the push-button retainer mechanism, which allows the push buttons to fall out of the switch housings. Printed circuit board failures include burned tracks and components.

The NSP (see Figure 1-1) consists of nine lighted push-button switches and one indicator mounted in two rows. Two NSPs are used on each C-141 aircraft to provide the pilot and copilot a means of switching navigation signals on their respective flight instruments. The NSP controls a bank of remotely located relays that perform the system switching. In addition, the unit contains relays for lamp testing and dimming, which are driven by lamp testing and dimming signals from the aircraft's electrical system. The NSP also contains a circuit board with diodes and resistors that control the electrical current to the lamps. A more complete description of the system can be found in the Technical Manual, Intermediate Maintenance Instructions with Illustrated Parts Breakdown, T.O. 5N6-9-9-2, dated 1 December 1979.

1.2 OBJECTIVE

The objective of the project was to provide engineering services and data to modify and improve the NSP in order to eliminate recurring failures and malfunctions. The project was divided into the following tasks:

- Task 1 - Analyze NSP operation and maintenance data compiled by Warner Robins Air Logistics Center (WR-ALC); identify faulty components requiring replacement or modification to improve overall reliability and maintainability.
- Task 2 - Design modifications to provide improved reliability and maintainability.

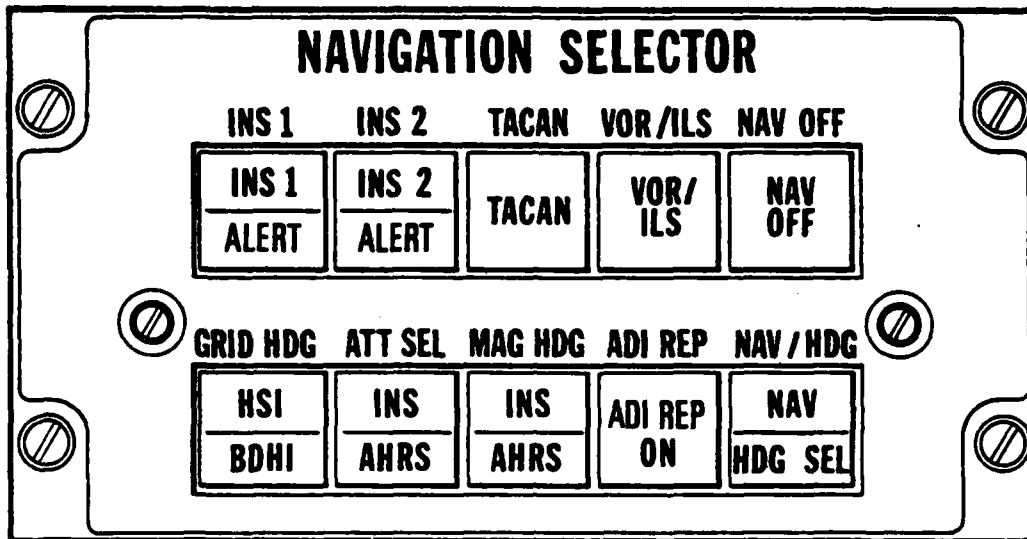

Figure 1-1. NAVIGATION SELECTOR PANEL (FRONT VIEW)

- Task 3 - Fabricate and assemble two modified NSP assemblies to demonstrate adequacy and compatibility of the improved configuration. Demonstrate that modified assemblies have the same form, fit, and functions as the original unmodified assemblies.
- Task 4 - Prepare a Level 3 data package in accordance with Data Item Description DI-E-7031, Drawings, Engineering and Associated Lists, dated May 1977, reflecting the changes introduced into the NSP.
- Task 5 - Prepare monthly status reports of work accomplished.
- Task 6 - Prepare a final status report of work accomplished.

Work on this contract was performed between 15 December 1980 and 31 December 1981.

1.3 REPORT ORGANIZATION

Chapter Two of this report reviews the efforts accomplished by describing the approach, discussing the actions and accomplishments, and explaining the results. Chapter Three presents the conclusions and recommendations.

CHAPTER TWO

DISCUSSION

2.1 APPROACH

The approach to the project was to identify the problem; find a solution; build prototypes and demonstrate that they satisfy existing form, fit, and function requirements for the Navigation Selector Panel; and document the results. The tasks listed in paragraph 1.2 of Chapter One of this report support this approach. Task 1 was to analyze existing data to identify faulty components and, in effect, determined the problem. Task 2 was to design modifications or, in other words, find a solution. Task 3 was to fabricate and assemble two modified NSPs and demonstrate that form, fit, and functions of the original NSP were maintained. Tasks 4, 5, and 6 were the documentation of the results.

2.2 ACCOMPLISHMENTS

2.2.1 Task 1

The data received from WR-ALC for analysis were contained in three automated reports: Detail Maintenance Actions For Selected Work Unit Codes, Reports Control Symbol (RCS) LOG-MMO<AR>7167; Detail Shop Actions For Selected Work Unit Codes and Parts Replaced During Repair, RCS LOG-MMO<AR>7168; and Summarized Maintenance Actions For Selected Work Unit Codes, RCS LOG-MMO<AR>7169. All three reports covered the twelve-month period ending 31 December 1979. Two of the reports were ambiguous so that it was not always possible to determine which component of the NSP failed or the exact nature of the problem. The other report, Parts Replaced During Repair, listed, by part number, the parts replaced and is summarized in Table 2-1. The part numbers listed in the report were separated into four categories: lamps belonging to the switches; components of the switch assembly, except for lamps; components of the circuit board assembly; and other. Disregarding the lamp failures, 73 percent of the parts replaced during the twelve-month period ending 31 December 1979 were switch assembly components.

We examined and inspected the switches and switch assemblies that were components of the two GFE NSPs provided by WR-ALC under the terms of the contract. The switches and switch assemblies used in the navigation selector panel are illustrated in Figure 2-1 and identified in Table 2-2.

Table 2-1. SUMMARY OF PARTS REPLACED

Part	Quantity	Percent of Total	Percent of Total Less Lamps
Lamp	389	46.6	--
Switch	325	39	73
Circuit Board	87	10.4	19.6
Other	33	4	7.4

A major problem can occur with this switch. The sleeve on the push-button module fits over the center pin in the switch body (see Figure 2-2) and is designed so that it snaps into place and is retained to the switch body by a ridge on the guide pin (see Figure 2-3). The dimensions of the push-button module, its sleeve, the switch body and its center guide pin are such that the module must be precisely aligned before any attempt is made to seat it. If not properly aligned, the sleeve does not fit over the pin but, instead, will slide alongside and will bend the guide pin as the module is pressed into the switch body. Eleven of the 20 guide pins in the assemblies examined were bent to some degree and two of them to such a degree that the push-button module could not be inserted into the switch body. There was one case of the sleeve being broken off the module and one case of the module being jammed into the switch body so that it could not be extracted. Both of these situations probably resulted from misalignment of the sleeve and guide pin.

We also discovered that the center guide pin could be bent so that contact was made with the lamp contacts, which could easily cause a short in a lamp circuit. This, in turn, could cause a component failure on the circuit board due to excessive current through the diodes and resistors. Although it was not possible to prove, it is speculated that this situation may have been a cause for some of the circuit board failures reported.

Maintenance was made more difficult and more expensive because the top row of interlocked switches (see No. 85 in Figure 2-1) were spot-welded together as required by the design of the mechanical interlock mechanism. As a result, if one of the switches failed, all five had to be discarded and a new assembly of five used to replace them. The assembly is not a repairable item and represents a considerable loss when discarded. In addition, the replacement of the assembly requires a considerable expenditure of time because 23 solder terminals must be disconnected and reconnected, some terminating more than one wire. As a result of these examinations, it was readily apparent that a replacement for the present switch assembly was needed.

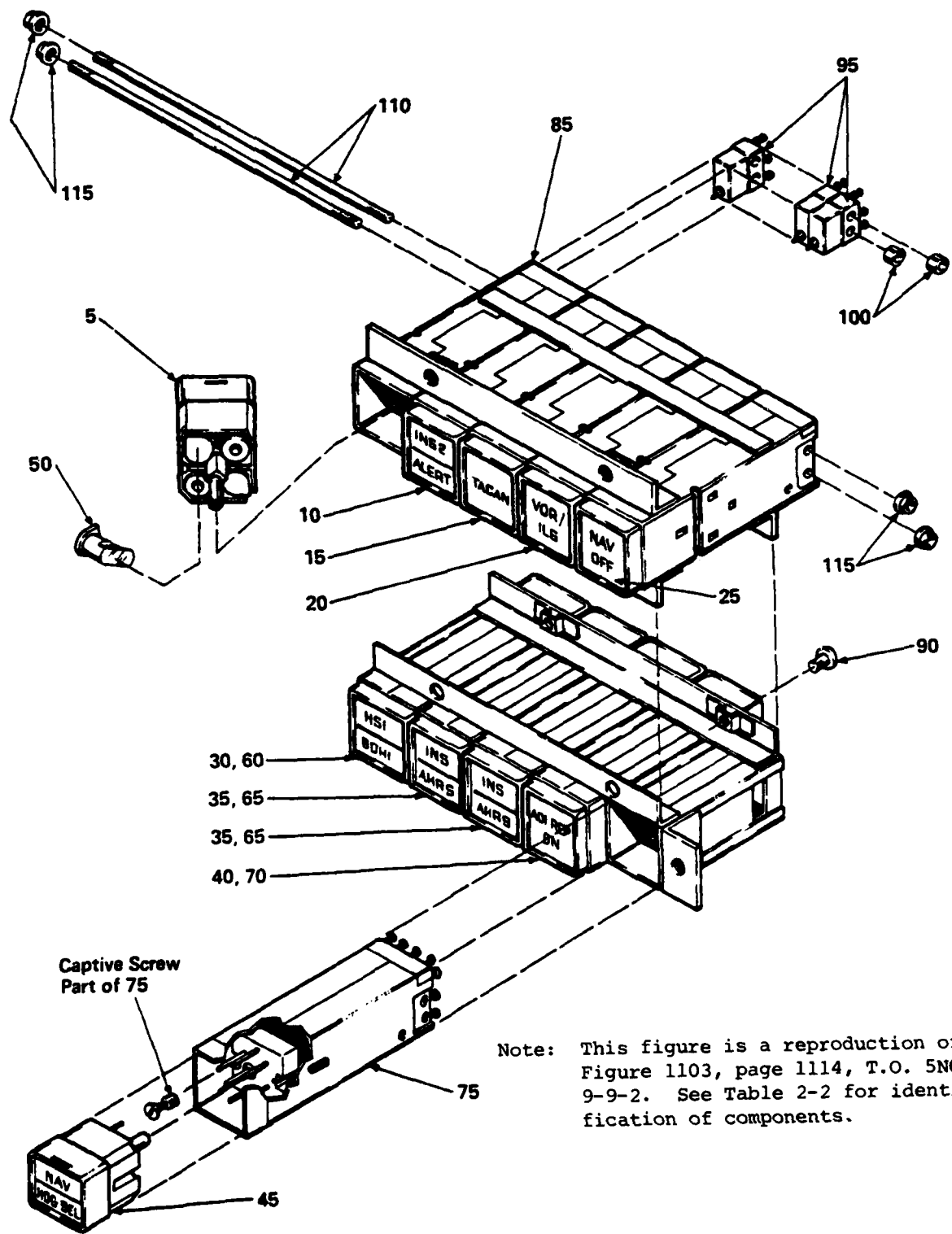

Figure 2-1. SWITCH ASSEMBLY

Table 2-2. PARTS IDENTIFICATION FOR SWITCH ASSEMBLY, FIGURE 2-1								
FIG. ITEM	PART NUMBER	1	2	3	4	5	6 7 NOMENCLATURE	UNITS PER ASSY
1103-1	311-711-2402-001	SWITCH ASSY (V81590) (75-89242-001) (See figure 1101 for NHA)						RF
5	711-2402-001	. CAP ASSY, INS1/ALERT (V81590) (75-89242-002)						1
10	711-2402-002	. CAP ASSY, INS2/ALERT (V81590) (75-89242-003)						1
15	711-2402-003	. CAP ASSY, TACAN (V81590) (75-89242-004)						1
20	711-2402-004	. CAP ASSY, VOR/ILS (V81590) (75-89242-005)						1
25	711-2402-005	. CAP ASSY, NAV OFF (V81590) (75-89242-006)						1
30	711-2402-006	. CAP ASSY, HSI/BDHI (V81590) (75-89242-007)						1
35	711-2402-007	. CAP ASSY, INS/AHRS (V81590) (75-89242-008)						2
40	711-2402-009	. CAP ASSY, ADI REP ON (V81590) (75-89242-010)						1
45	711-2402-010	. CAP ASSY, NAV/HDG SEL (V81590) (75-89242-011)						1
50	711-73	. . PLUG, Reflective lamp (V81590) (Used with items 5 thru 45)						20
55	311-2402-001	. BASE ASSY (V81590) (75-89242-012)						1
60	311-2402-162	. . INDICATOR (V81590) (75-89242-014)						1
65	311-2402-103	. . SWITCH (V81590) (75-89242-015)						2
70	311-2402-104	. . SWITCH (V81590) (75-89242-016)						1
75	311-2402-105	. . SWITCH (V81590) (75-89242-017)						1
80	311-97-19	. . FRAME ASSY (V81590)						1
85	311-2402-101	. . SWITCH ASSY, Interlock (V81590) (75-89242-013)						1
90	000-110-027	ATTACHING PARTS . . SCREW, RH 4-40						2
95	MS24547-4	. . . SWITCH ATTACHING PARTS						15
100		. . . FILLER, Space						8
110	311-204	. . . ROD, Threaded (V81590)						2
115	000-070-045	. . . NUT (V81590)						4

Note: This table is reproduced from the table on page 1115 of T.O. 5N6-9-9-2.

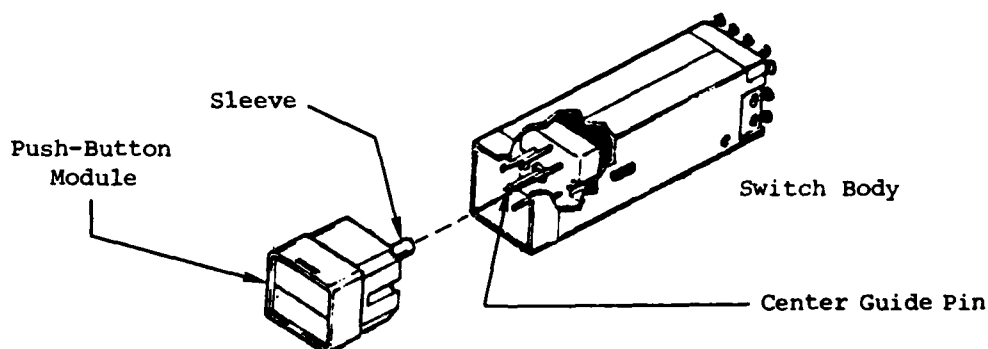

Figure 2-2. PRESENT SWITCH

Other actions completed as part of Task 1 included the acquisition of the Technical Manual, Intermediate Maintenance Instructions With Illustrated Parts Breakdown, T.O. 5N6-9-9-2, dated 1 December 1979, and the level 3 data package produced by Electrospace Systems, Inc. (ESI), the manufacturer

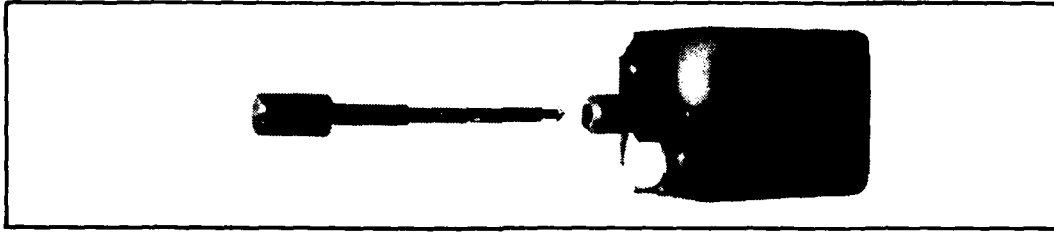

Figure 2-3. PUSH-BUTTON MODULE AND
CENTER GUIDE PIN

of the NSP. In addition, we conducted a market survey of switch manufacturers and requested samples in a search for a replacement for the present switches. Following is a list of manufacturers whose product lines we examined:

- Aerospace Optices, Inc., of Chicago, Illinois
- Airpax Electronics, Inc., of Cambridge, Maryland
- C&K Components, Inc., of Watertown, Maryland
- Compu-Lite Corporation of Costa Mesa, California
- EAO Switch Corporation of Milford, Connecticut
- Electro-Components Division, AMF, Inc., of Hollywood, Florida
- Grayhill, Inc., of LaGrange, Illinois
- IEE/Schadow, Inc., of Eden Prairie, Minnesota
- Jay-El Products, Inc., of Gardena, California
- Korry Manufacturing Company of Seattle, Washington
- Licon Division, Illinois Tool Works, Inc., of Chicago, Illinois
- Master Specialties Company of Costa Mesa, California
- Stacoswitch, Inc., of Costa Mesa, California
- Switchcraft, Inc., of Chicago, Illinois

2.2.2 Task 2

The design concept was to replace the present switches with switches possessing the following characteristics, if possible:

- Provide the same capabilities and operational characteristics as the present switches
- Fit into the spaces occupied by the present switches
- Cause no redesign or modification of the circuit board
- Cause no repositioning of components within the NSP
- Cause no redesign or modification of the front and edge-lit panels

This concept allows for correction of the major deficiency, at minimal expense, while satisfying the form, fit, and function requirements of the NSP. Other considerations were to find a solution to the maintainability problem presented by the interlocked switches and to use a switch that was qualified under the Military Specification, Switch, Push Button, Illuminated, General Specification for, MIL-S-22885C, dated 6 July 1971. A survey of the product lines of the manufacturers listed in paragraph 2.2.1 resulted in the selection of five switches that satisfied most of the characteristics. A comparison of these switches with the present switch is contained in Table 2-3. All six of the switches in Table 2-3 provided the same capabilities and operational characteristics except for the pushbutton module action. Some provide the feature of remaining depressed while the switch is active. None would necessitate a redesign or modification of the circuit board. The other characteristics are dealt with in the table.

We discussed the advantages and disadvantages of the various switches at the preliminary design review (PDR) at WR-ALC on March 12, 1981. As a result of the PDR, the Jay-EI switch was selected as the most satisfactory, and the development of the prototypes continued using that switch. The overriding considerations were that the switch is qualified under MIL-S-22885C, its use would cause no changes to the other components or layout of the NSP, and the use of a holding coil in an electrical interlock configuration would allow for individual replacement of switches.

The selection of the Jay-EI switch also determined the hardware requirements. A new switch housing bracket was designed to accommodate the switches and fabrication was ordered (see Figure 2-4 for new switch assembly design). The Jay-EI switches were also ordered (see paragraph 2.2.3 for a discussion of the fabrication and assembly actions).

Due to delays in delivery of the switches, the critical design review (CDR) was not held until September 10, 1981. By that time, the critical item product fabrication specification for the lighted pushbutton switch assembly had been drafted along with necessary drawings. The specification and drawings were presented at the CDR and no significant changes were made. Following final delivery of the switches and assembly of the two modified NSPs, they were taken to McGuire AFB for testing on the control unit tester (CUT). The CUT provides a means of fully checking the functional capabilities of the NSP. The test procedures used were those found in T.O. 5N6-9-9-2, pages 701 through 704. The testing demonstrated that the NSPs performed as required and that the CUT requires no modification to test the modified panels. Changes to the test procedures and manual will be minimal. Only fault indications for the holding coils need to be added.

2.2.3 Task 3

The efforts under this task were directed toward the acquisition of parts, assembly of two modified NSPs, demonstration of form, fit, and function, and delivery of the two modified NSPs to the Air Force.

Table 2-3. SWITCH COMPARISON

Switch Type	MIL SPEC Qualified?	Interlock Type	Panel Parts Need Relocation?	Front Panel Needs Modification?	Maintained Depressed Pushbutton	Published Life Mech/Elect. (Cycles)	Switch Length (Inches)	Special Considerations
Present Switch	Yes	Mechanical	No	No	Yes	100,000	2.57	- High failure rate due to mechanical design
Korfy 450 Series	No	Mechanical	No	Yes	Yes	100,000	2.33	- Two lamps instead of four - Nonmoving lamps
Vivisun 20/20	Yes (Assume Relays MIL SPEC Qualification)	None Supplied (Suggest Five Relays)	Yes (To Add Five Relays)	No	No	50,000/25,000	2.24	- High sunlight readability - Low touch temperature - Addition of five relays
Master Specialties Series 800	Not with Holding Coil	Holding Coil	Yes	Yes	No	100,000/25,000	3.07 (w/o coil)	- Plug-in switch replacement
Switchcraft 38000 Series	No	Mechanical	No	Yes	Yes	100,000	2.61	- Two lamps instead of four - Large plastic button
Jay-El Mark 8	Yes	Holding Coil	No	No	No	100,000/25,000	2.68	- Jay-El on QPL - Switch used on other Air Force equipment - Sunlight readability available

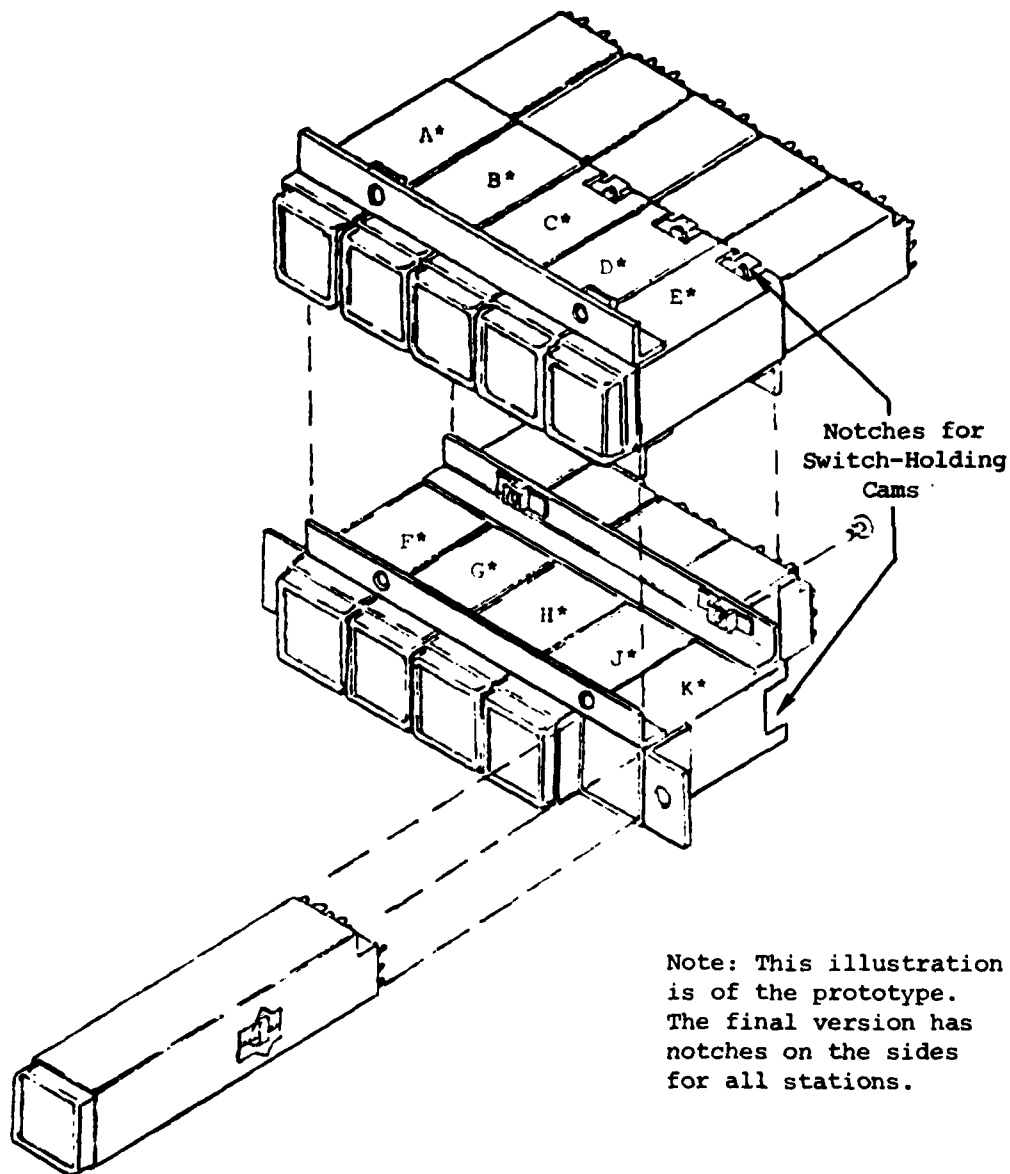

*Station designation.

Figure 2-4. SWITCH ASSEMBLY AND STATION LOCATIONS

As a result of efforts conducted under Tasks 1 and 2, the Jay-E1 Mark 8 series switch was selected as the replacement for the present switch. The first step under this task was to order the appropriate switches from Jay-E1. The indicator and four alternate action switches required for the

bottom row of the assembly and three of the top row switches with holding coils posed no ordering problems. Two of the top-row switches required a split-ground for the lamp circuits as well as a holding coil, and this was not a standard combination for Jay-El switches. Jay-El engineers said that it would not present a design or manufacturing problem, but it would be a special order and would take somewhat longer for delivery. In order to start work on the panels at the earliest possible time, two orders were placed. The first was for ten switches with holding coils, eight alternate action switches, and two indicators. Estimated delivery time was two months after receipt of the order (ARO). The second order was for five switches with holding coils and split-ground lamp circuits and pushbutton modules with the proper legends for all switches. The provision of proper legends made delivery within two months ARO impossible. This second order had an estimated delivery time of four months ARO. Both orders were placed in May, 1981, with projected delivery dates of July 8 for the first order and September 16 for the second.

The completed designs for the upper and lower housing brackets were used to order two of each of the brackets from a local Annapolis, Maryland, firm. The search for a company to make the brackets took nearly two months since most of the firms contacted were reluctant to take on such a small job for a special design. An order was finally placed on July 23, with a projected delivery date of August 5. The order was cancelled on August 27, when the firm could not guarantee delivery by August 31. Another company was selected, an order placed, and the brackets were delivered on September 4.

In the interim, Jay-El had experienced production problems and the delivery of the first order, due on July 8, was not received until August 14. The second order was delayed until November 6. The results of these delays were two contract extensions, the first to October 31 and the second to December 31. The main problem, according to Jay-El engineers, was that insulation used internally in the switches with a holding coil was defective and the first set of switches experienced internal shorting. By the time this problem was diagnosed and new materials were ordered, delivery of both orders was delayed two months.

The two switch assemblies and NSPs were completely assembled following delivery of the second order, and arrangements were made to take them to McGuire AFB for testing on the CUT using the test procedures in T.O. 5N6-9-9-2. The tests were conducted by Mr. H. Riser of ARINC Research Corporation and Mr. J. Tye of WR-ALC on December 9. During the course of the test, one switch was found to be defective and was replaced with a spare. Another problem occurred when a lamp circuit in one of the switches was short-circuited. Displaced insulation on one of the lamp terminals on the switch was the cause. The insulation was replaced and both panels operated properly. The legends on three modules, stations C, D, and E in Figure 2-4 (see item numbers 15, 20, and 25 on Figure 2-1), were rotated 90 degrees clockwise because of a mistake in ordering. When the orders were initially prepared, we mistakenly believed that a certain legend style was needed that required that the switch body be rotated 90 degrees.

It did not have to be. The design of the upper housing bracket has been corrected to allow proper installation of the switch bodies. Figure 2-4 shows the rotation of the switches as they were assembled. Compare the notches for the switch holding cams in Station E with Station K. All should be like Station K.

Following completion of the tests the two assembled NSPs were turned over to Mr. J. Tye of WR-ALC, who delivered them to WR-ALC on December 14.

2.2.4 Task 4

This task covered the documentation of the changes made in the NSP. The primary changes are reflected in the Critical Item Fabrication Specification, Assembly, Switch, Lighted Pushbutton, 29562-2315-11-2563, dated 30 November 1981. We completely reviewed the ESI data package and made required changes. The method of change was, in most cases, the replacement of an ESI drawing with an ARINC Research Corporation drawing. A summary of the changes is contained in Table 2-4.

The two critical item fabrication specifications were delivered 4 January 1982. Preliminary copies of all drawings were delivered to Mr. J. Tye on 10 December 1981. Upon receipt of comments and approval of changes by WR-ALC, final copies of the drawings will be provided in accordance with the terms of this contract.

2.2.5 Tasks 5 and 6

These tasks were the preparation of the monthly status reports and the final report and need no further explanation.

2.3 RESULTS

The major result of this project is the design of a modification to the NSP that will provide a replacement for the switches that are causing 39 percent of all replacement actions and 73 percent of all replacements excluding lamps. Although it was not within the scope of the contract to test the reliability of the switch, we asked several other users of the Jay-El Mark 8 switch and indicator if they had experienced any reliability problems with the switch or indicator.

The indicator is used in the F-15 and the switch in the ALR-46 and ALR-69 programs. Offices contacted at WR-ALC included MMARB, MMRSB, and MMRRBA. All users reported no problems with the indicator or switches. In addition, Applied Technology, Inc. (ATI) has selected the switch for use in the Wild Weasel system. Mr. J. McLaughlin of ATI was very positive about the reliability of the switch and said that ATI had no problems with it.

The design allows for individual replacement of switches in the top row, which will improve the maintainability of the NSP as less time is required to remove and replace one switch rather than all five. This should also decrease parts costs for replacement since the Jay-El switch is approximately \$65.00, while the top assembly is approximately \$350.00.

Table 2-4. DOCUMENTATION CHANGES

ESI Drawing		ARINC Research Corporation Drawing	
Number	Title	Number	Title
75-89101	Navigation Selector Assembly	002975	Navigation Selector Assembly
75-89184	Edgelight Panel	002981	Edgelight Panel
75-89198	Wiring, Point-to-Point	002982	Wiring, Point-to-Point
75-98199 75-89246	Wiring Diagram Wiring Diagram	002986	Wiring Diagram (Replaces both 75-89199 and 75-89246)
75-89200	Test Procedure	002983	Test Procedure
75-89201	Data Sheet	002984	Data Sheet
75-89215 75-89242	Switch Assembly Switch Assembly	Specification 29562-2315- 11-2563	Critical Item Fabrication Specification, Assembly, Switch, Lighted Pushbutton (Replaces both ESI drawings 75-89215 and 75-89242)
75-89221	Specification	Specification 29562-2315- 11-2569	Critical Item Fabrication Specification, Panel, Navigation Selector, for C-141 Aircraft
Additional Drawings (Required by Specification 29562-2315-11-2563)			
		002976	Lighted Pushbutton Switch Assembly
		PL-002977	Parts List for Lighted Pushbutton Switch Assembly
		002978	Wiring and Interconnecting Diagram
		002979	Upper Matrix Housing Bracket
		002980	Lower Matrix Housing Bracket

The critical item fabrication specification and referenced drawings prepared as part of this study can be used to procure new switch assemblies, which can be retrofitted into the NSPs. This could be accomplished by intermediate maintenance shops using a time compliance technical order (T.C.T.O.) and done all at once or as replacement actions for faulty NSPs. Since no other components except the edge-lit panel in the NSP have been modified or repositioned, there is no need to procure new NSPs. The only modification to the edge-lit panel is an enlargement of the holes for the switches. This can be accomplished in less than an hour with a file and a template that could be provided as part of the modification kit. The area enlarged would have to be spot painted with a primer and flat black paint. This modification is well within the capabilities of a base maintenance shop.

In the event new NSPs must be procured, the data package has been updated and is ready to be used in a procurement action.

CHAPTER THREE

CONCLUSIONS AND RECOMMENDATION

3.1 CONCLUSIONS

The following conclusions have been made as a result of this project:

- Replacement of the present switches would enhance the reliability and maintainability of the NSP.
- The concept and design developed by this project provide a feasible solution to the switch problem.

3.2 RECOMMENDATIONS

It is recommended that an engineering change proposal be initiated to adopt the concept and design developed by this project to replace the present switches and switch assembly.

FILMED
— 8