

AD-A11 484

VANDERBILT UNIV NASHVILLE TN DEPT OF PSYCHOLOGY
THE CONSTANCY OF STEREOSCOPIC DEPTH PERCEPTION. (U)
JAN 82 R H CORMACK

F/6 5/10

N00014-81-C-0001

NL

UNCLASSIFIED

1 of 1
50
5/1/82

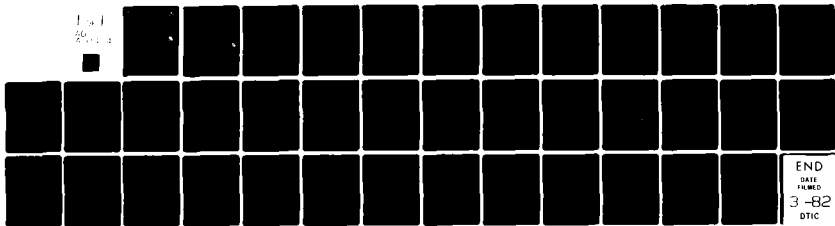

END
DATE
FILMED
3-82
DTIC

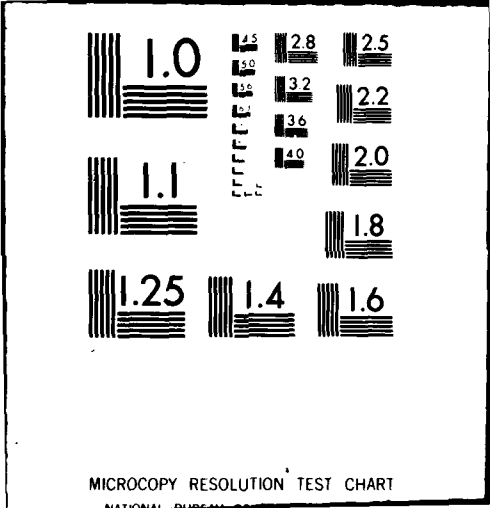

AD A111484

Report #00014-02-C-01

The Constancy of Stereoscopic Depth Perception

Robert H. Cormack

Department of Psychology
Vanderbilt University
Nashville, Tennessee 37240

DTIC
COLLECTED
MAR 2 1962

FILE COPY

January 1962

Technical Report

AD A111484

Final Report

AD A111484

08 02 030

Unclassified

SECURITY CLASSIFICATION OF THIS PAGE (When Data Entered)

REPORT DOCUMENTATION PAGE		READ INSTRUCTIONS BEFORE COMPLETING FORM
1. REPORT NUMBER N00014-82-C-01	2. GOVT ACCESSION NO. AD-A111484	3. RECIPIENT'S CATALOG NUMBER
4. TITLE (and Subtitle) The Constancy of Stereoscopic Depth Perception	5. TYPE OF REPORT & PERIOD COVERED Technical Report	
7. AUTHOR(s) Robert H. Cormack	6. PERFORMING ORG. REPORT NUMBER	
9. PERFORMING ORGANIZATION NAME AND ADDRESS Vanderbilt University Nashville, Tennessee 37240	8. CONTRACT OR GRANT NUMBER(s) N00014-81-C-0001	
11. CONTROLLING OFFICE NAME AND ADDRESS Engineering Psychology Programs, ONR 800 North Quincy Street, Code 455 Arlington, Virginia 22217	10. PROGRAM ELEMENT, PROJECT, TASK AREA & WORK UNIT NUMBERS	
14. MONITORING AGENCY NAME & ADDRESS (if different from Controlling Office)	12. REPORT DATE 1982 January, 1981	
	13. NUMBER OF PAGES 36	
16. DISTRIBUTION STATEMENT (of this Report) For public release; distribution unlimited	15. SECURITY CLASS. (of this report) Unclassified	
	15a. DECLASSIFICATION/DOWNGRADING SCHEDULE	
17. DISTRIBUTION STATEMENT (of the abstract entered in Block 20, if different from Report)		
18. SUPPLEMENTARY NOTES		
19. KEY WORDS (Continue on reverse side if necessary and identify by block number) Depth constancy Stereopsis Afterimages Visual space perception Retinal disparity Depth perception		
20. ABSTRACT (Continue on reverse side if necessary and identify by block number) Depth constancy is said to occur when the apparent depth in a scene remains the same as viewing distance changes. Studies of depth constancy have left unanswered questions regarding the range of viewing distances over which depth constancy can operate and the role of retinal disparity in preserving apparently constant depth. In this study, stereoscopic		

DTIC
SELECTED
MAR 2 1982
D
H

DD FORM 1 JAN 73 1473

EDITION OF 1 NOV 65 IS OBSOLETE
S/N 0102-014-6601

Unclassified

SECURITY CLASSIFICATION OF THIS PAGE (When Data Entered)

Unclassified

SECURITY CLASSIFICATION OF THIS PAGE(When Data Entered)

→ afterimages were exploited to confront these questions. Afterimages containing depth information in the form of retinal disparity were produced and viewed at various fixation distances. Apparent depth in the afterimage was measured by asking observers to set a depth probe equidistant to the afterimage. This technique permitted holding retinal disparity constant as viewing distance changed. It allowed testing at very large viewing distances in the presence of multiple depth cues.

The results indicate that stereoscopic depth constancy can be preserved at viewing distances at least as great as 27 meters (the largest used). These changes were veridical and demonstrate that the relationship between perceived depth and retinal disparity is consistent with the geometry describing stereopsis. These findings set requirements for theories of depth constancy. Specifically, they demand that such theories show how retinal disparity can be correctly recalibrated on the basis of distance information available in the visual array.

Accession For	
NTIS GRA&I	<input checked="" type="checkbox"/>
DTIC TAB	<input type="checkbox"/>
Unannounced	<input type="checkbox"/>
Justification	
By	
Distribution/	
Availability Codes	
Dist	Avail and, or Special
A	



Unclassified

SECURITY CLASSIFICATION OF THIS PAGE(When Data Entered)

The Constancy of Stereoscopic Depth Perception

Perhaps the most widely known source of depth information is stereopsis, which refers to the perception of relative depth induced solely by the disparity that results from horizontally separated eyes. Stereopsis provides unique depth information unavailable to a single eye and it is an extremely sensitive phenomenon--angular differences between objects in space of only a few seconds of arc can be discriminated. Yet these discriminations yield only information about the relative differences between the objects. To provide absolute or metric information about the veridical distances between them requires supplementation of stereopsis by information about the absolute distance between the observer and the objects. This requirement is analogous to the case of size perception wherein the size of the proximal stimulus must be supplemented by information about its distance from the observer to obtain a veridical perception of size. The process through which veridical size perception occurs is referred to in the literature as the phenomenon of size constancy. Similarly, the veridical perception of stereoscopic depth intervals requires the phenomenon of depth constancy.

The question of whether depth constancy is operative for stereoscopic depth has received surprisingly little attention in view of the considerable research activity stereopsis has generated. Only a small number of experiments have investigated the constancy question directly and these have recently been summarized and reviewed by Ono and Comerford (1977). The general conclusion derived from these studies is that constancy is present at relatively short viewing distances on the order of 200 cm, but is absent at longer distances. This is a puzzling finding in view of the

much greater distances over which stereopsis, at least in theory, could operate. It should be noted, however, that these experiments used impoverished stimulus situations in which the cues for absolute distance were effective only over short distances.

In the research described in this report, depth constancy in stereopsis was investigated by methods that permitted absolute depth information to be effective over much greater distances. Under these conditions the results clearly indicate that constancy is essentially perfect for distances of up to at least 27 meters, the largest value tested.

Before turning directly to a description of that research, however, it will be helpful to review briefly the geometrical relationships underlying retinal disparity and the way they define the requirements that a depth constancy mechanism must fulfill.

Figure 1 illustrates the simplest case for the determination of retinal disparity. The two eyes are shown as R.E. (right eye) and L.E. (left eye). Interpupillary distance (IPD) typically ranges from 6.0 to 7.0 cm. We may take 6.5 cm as a convenient average. The square and hexagon are two objects or targets in space. If the two eyes are fixating the square, as in Fig. 1A, then the images of the square in the two eyes will fall on corresponding points (center of fovea) while the images of the hexagon will fall on non-corresponding points. Fixation distance is represented by "D" while the depth interval is " Δ ". Since the images of the square and hexagon fall in the same location in the left eye, the angular separation of these images in the right eye (δ) represents the retinal disparity. Gamma is easily determined by subtracting angle "a" from angle "b". The tangent of angle "a" is the ratio of D (side opposite) to IPD (side adjacent). Therefore, angle "a" is equal to the arc tangent of this ratio. By the

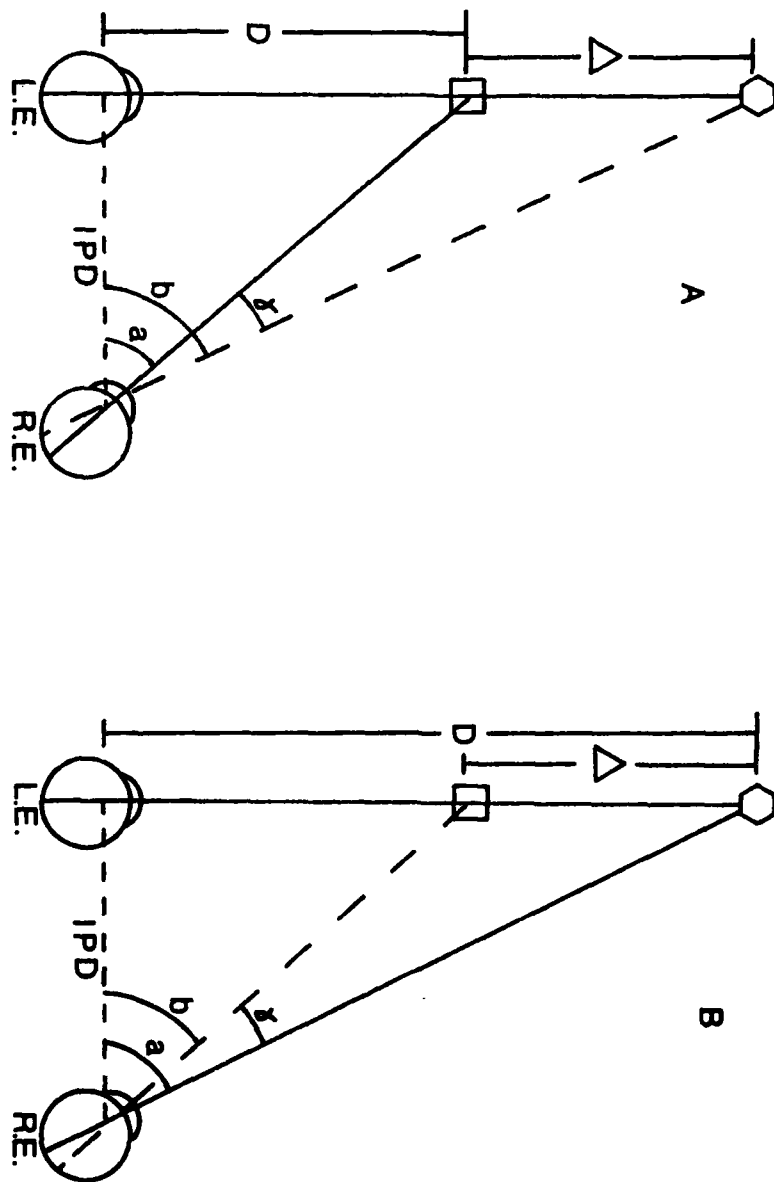

Figure 1. Simplest case for calculating retinal disparity. D = fixation distance; Δ = depth interval; IPD = interpupillary distance; δ = retinal disparity. Figure 1A represents uncrossed disparity. Figure 1B represents crossed disparity.

same argument, angle "b" is equal to the arc tangent of the ratio of $D + \Delta$ (side opposite) to IPD (side adjacent). This leads to the following formula for retinal disparity:

$$1) \delta = \text{ATN}((D + \Delta) / \text{IPD}) - \text{ATN}(D / \text{IPD})$$

The case described is, by convention, termed "uncrossed disparity". This simply refers to the case where the object fixated is nearer the object whose images fall on disparate retinal locations. Were the eyes to fixate the hexagon the disparity would be crossed. This is shown in Fig. 1B. Fixation distance (D) is now the distance to the hexagon. The depth interval (Δ) is the same but in the opposite direction, i.e., the disparate target is nearer. If the depth interval is expressed as a negative value, we may still use formula 1 and retinal disparity (δ) will assume a negative value, thereby indicating crossed disparity.

A more realistic case is shown in Fig. 2. Here the targets are not lined up with one eye but instead are in the median plane bisecting the two eyes. Convergence is symmetrical; i.e., the two eyes turn inward equally. If both eyes fixate the square, as in Fig. 2A, then the disparity of the images of the hexagon will be shared equally by the two eyes. Angle "C" will thus represent one-half of the retinal disparity. Note that angle "C" may be determined exactly as gamma was determined in Fig. 1, except that the side adjacent is one-half the interpupillary distance. Retinal disparity for Fig. 2A may be calculated by formula 2.

The crossed disparity case (Fig. 2B) is also covered by formula 2. As in the simpler case, the depth interval is expressed as a negative value, and disparity similarly becomes negative.

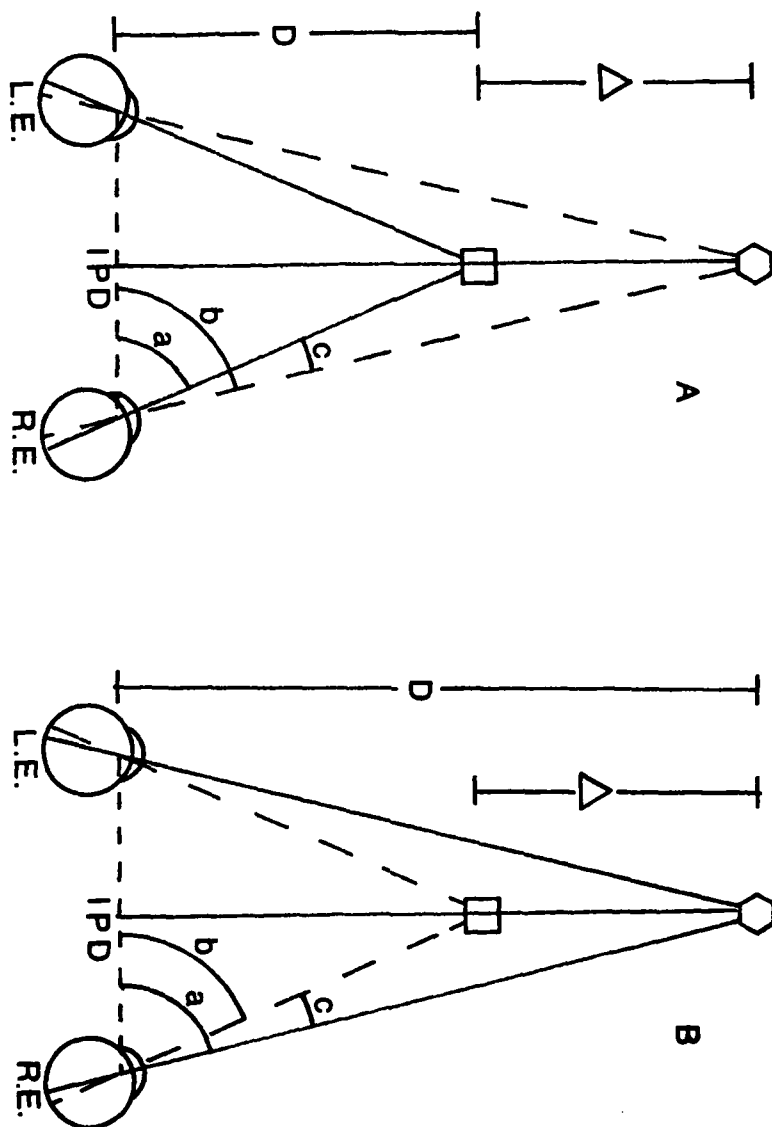

Figure 2. Geometry of retinal disparity used in this paper. D = fixation distance; Δ = depth interval; IPD = interocular distance. Angle C equals one-half the retinal disparity. Figure 2A represents uncrossed disparity. Figure 2B represents crossed disparity.

When neither target is in the median plane, and when convergence is not symmetrical, the calculation of retinal disparity can become more complicated. Two points should be noted. First, regardless of the locations of the target, the function relating target distances and depth intervals to retinal disparity is the same trigonometric one. I shall describe this function in more detail below. Second, so long as the depth interval (Δ) is small relative to fixation distance (D) and so long as convergence is roughly symmetrical (within a few degrees) the formula 2 provides a good approximation to gamma (δ). I shall therefore use formula 2 for the remainder of this discussion.

Look now at the trigonometric function relating " δ " to " D " and " Δ ". Figure 3 shows what happens to the retinal disparity (δ) produced by a fixed depth interval (Δ) as fixation distance is varied. The depth interval is 5 cm., disparity is uncrossed. Notice that disparity decreases dramatically as the fixation distance goes from 15 cm. to 60 cm., but drops less rapidly thereafter. Replotting these data into logarithmic form will allow a greater range of values and make clearer the nature of the relationship.

Figure 4 shows the same function plotted in Log (base 10) Form. The abscissa gives log distance and the ordinate gives log retinal disparity in degrees. The depth interval is still 5 cm. The solid line is the same curve shown in Fig. 4. The dashed line is a straight line whose slope is minus two, i.e., an inverse square law. The two lines deviate only for small viewing distances (<100 cm.), showing that, in general, retinal disparity decreases as the square of fixation distance.

The function shown in Figs. 3 and 4 is important for an understanding

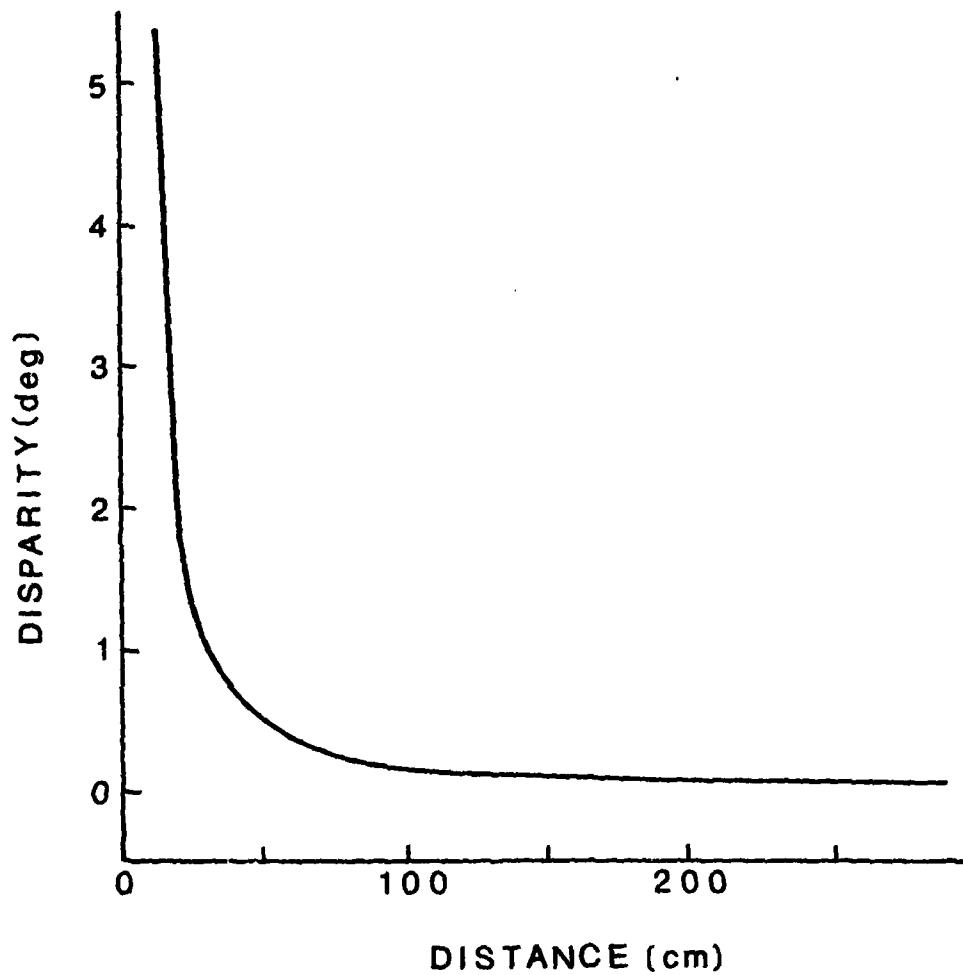

Figure 3. Retinal disparity in degrees as a function of fixation distance in cm for a depth interval of 5 cm.

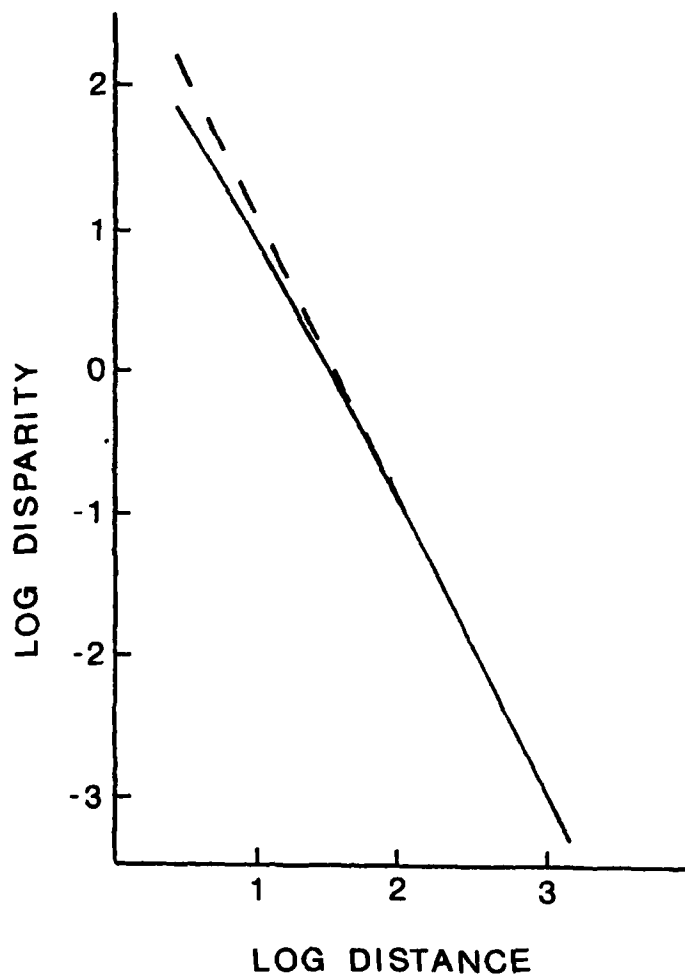

Figure 4. Retinal disparity as a function of fixation distance plotted in Log-Log coordinates. The solid line is the function from Figure 3. The dotted line has a slope of -2, representing an inverse square relationship.

of depth constancy for it shows that disparity must be corrected for viewing distance to yield veridical depth judgements. Just as a given image size represents larger objects at greater viewing distances, so a given retinal disparity must represent greater depth intervals at greater viewing distances. But unlike the case of image size in which the object represented grows linearly with distance, depth intervals represented by a given retinal disparity must increase in accordance with the function shown in Figs. 3 and 4, i.e., nearly as the square of the distance. This is illustrated in Fig. 5, in which the function is recast to show the relationship between depth interval and viewing distance for a given retinal disparity in Log units. The dotted line in Fig. 5 has a slope of two and thus illustrates what would happen if depth increased as the square of viewing distance. The two curves show the actual relationship between viewing distance and the depth interval represented by 15 min of retinal disparity. The two curves are necessary because the relationship is different for crossed and uncrossed disparity.

In the case of uncrossed disparity, it should be evident that if the viewing distance is so great that the convergence angle of the eyes is equal to the disparity, then the depth interval becomes infinite. In Fig. 5 this is shown by the upper curve which becomes vertical at ≈ 3.0 Log cm. With crossed disparity the situation is quite different. Clearly the depth interval cannot increase as the square of the viewing distance without bound, for in that case the disparate object would eventually fall behind the head of the viewer (when the depth interval exceeded the viewing distance). In fact, geometry dictates that at short viewing distances the depth interval grows at nearly the square of viewing distance and then

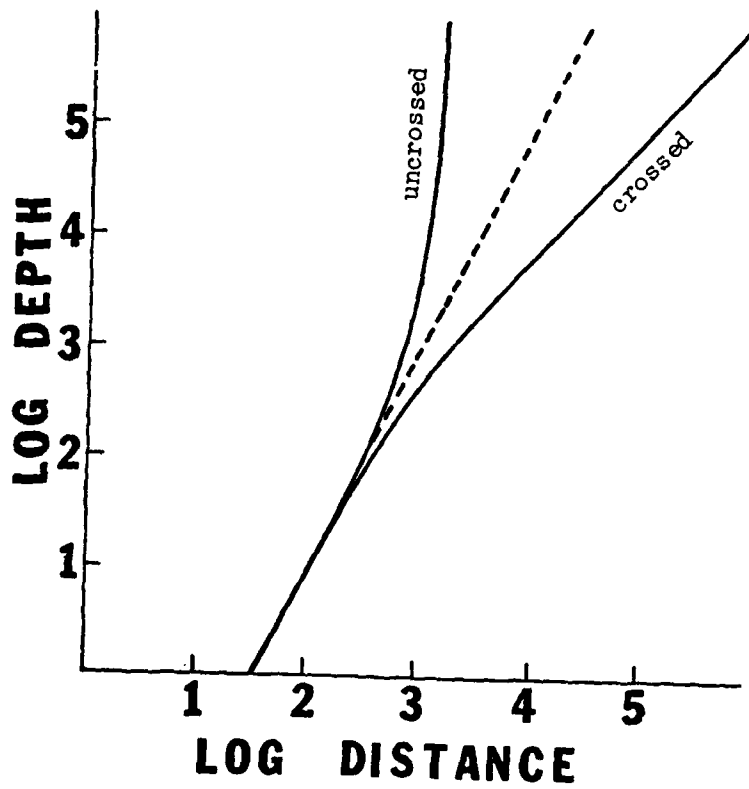

Figure 5. Depth interval required to produce 15 min. retinal disparity as a function of fixation distance. Dotted line has a slope of 2.

more slowly approaching a linear function. The effect of this is that at sufficiently great viewing distances the object in crossed disparity appears at a nearly constant egocentric distance (distance from the observer) even though fixation distance continues to increase. This is shown in Fig. 6 for two values of retinal disparity.

What I have discussed thus far might be termed the geometry of retinal disparity. It describes what occurs in the two retinae as fixation distances, depth intervals and retinal disparities vary. This geometry has been known since the work of Wheatstone (1838) and Helmholtz (1866). Except for minor details (e.g., how to measure IPD) there is no controversy regarding the geometry. There is controversy as to whether this geometry correctly describes perceived depth, especially as mentioned previously, at large viewing distances. This controversy will be treated in some detail in the Discussion section.

In this study I have attempted to test directly whether the perceived depth interval produced by a given retinal disparity grows with fixation distance as it must if stereoscopic depth constancy operates. The nature of this growth is compared to the growth predicted by the geometry of stereopsis. In order to hold retinal disparity constant a stereoscopic afterimage was employed. Such an afterimage containing depth information can be induced at one distance and then viewed at another. Disparity cannot change; it is, as it were, painted on the retina. This technique allowed the use of extremely long viewing distances in the presence of multiple depth cues. The approach bears a close similarity to the classical Emmert's law experiment in which the apparent size of an afterimage varies with its apparent distance. In the present case, the question is whether the apparent depth in an afterimage varies with apparent distance

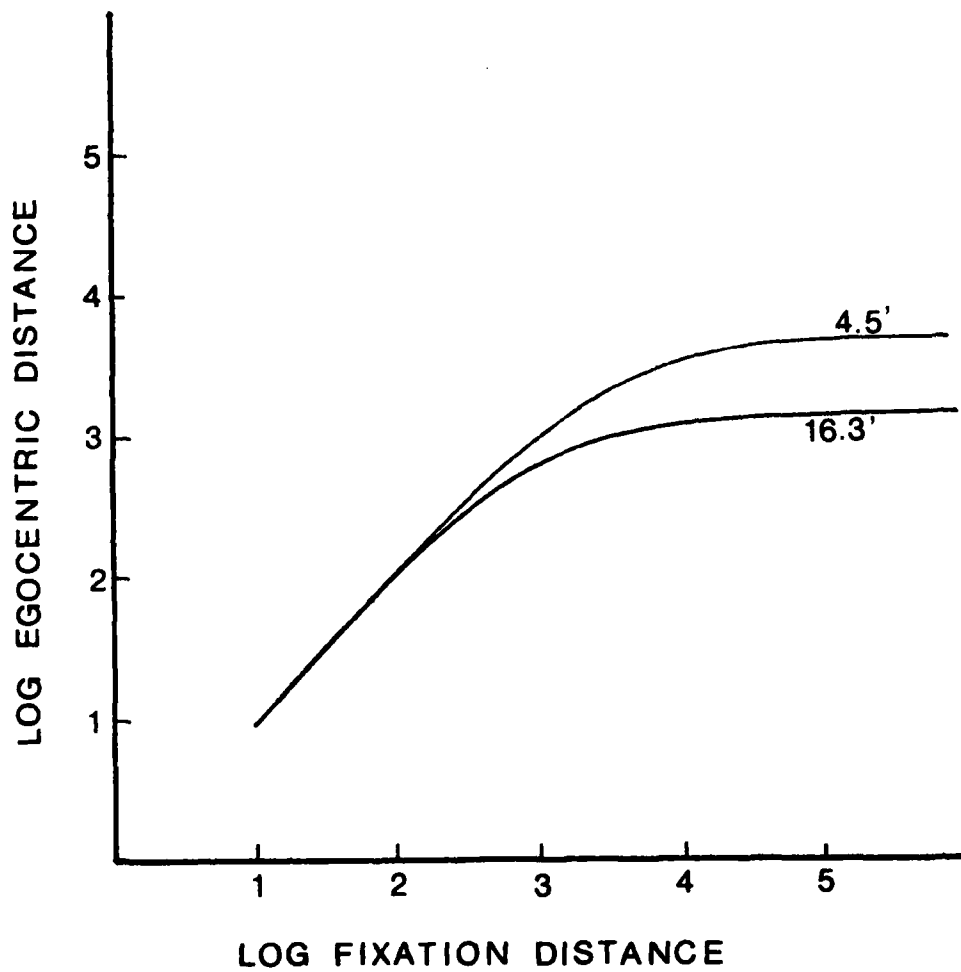

Figure 6. Egocentric distance of a target in crossed disparity as a function of fixation distance for 4.5 min. and 16.3 min. of disparity.

in accordance with the functions described in Fig. 5.

Method

The inspection stimulus (I-fig) used to produce an afterimage is shown in Fig. 7. The circles were punched into black vinyl tape and mounted on a glass plate as shown in Fig. 8A. The fixation point and the ends of the horizontal bar (Fig. 8B) were also made of black vinyl tape and were mounted on another glass plate. The plates were then placed one behind the other with spacers between them to produce the desired separation in depth. This glass sandwich was mounted at eye level on an optical bench (see Fig. 9). Immediately behind the target was a white plastic diffusing screen and behind that a Honeywell Strobonar 800 flashgun, and a small dim light which transilluminated the target. In front of the target at the end of the optic bench were mounted a chin rest and head stabilizer. A subject-controlled pushbutton triggered the flashgun and initiated a 5 hz flickering light.

Two test stimuli were employed. For test distances < 450 cm, the arrangement shown in Fig. 10 was employed. A 6 mm white fixation point was mounted on a thin (1 cm) vertical rod. This rod was located on a long (255 cm) table so arranged that by turning 90° from the inspection target the observer could look down the table to the test fixation point. A second vertical rod lacking a fixation point served as a depth probe and was located to the right of the fixation target. This rod could be moved toward or away from the observer until it appeared in the plane of the afterimage of the circles. A chin rest was mounted at the observer's end of the table, and a black shield occluded the observer's view of the table surface. A flashing (5 hz) 75-watt incandescent bulb maintained afterimage

Inspection target. Background is opaque.
 Translucent circles stand out in depth
 from the center fixation square and trans-
 lucent horizontal bar.

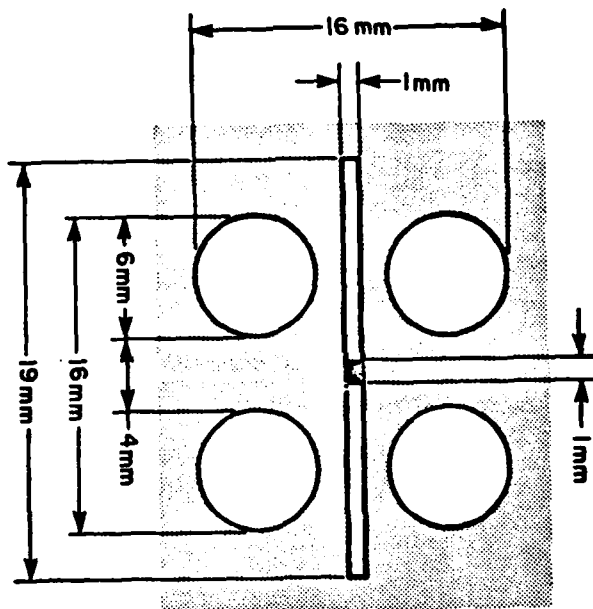

Figure 7. Inspection target. Background is opaque. Translucent circles are in a different depth plane than the center fixation square and translucent horizontal bar.

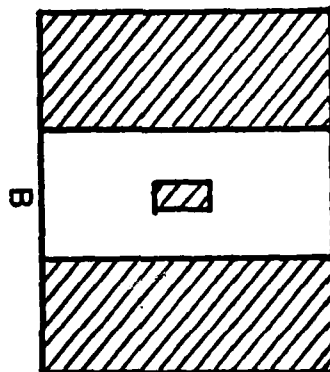
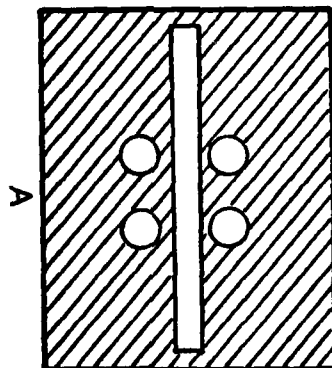

Figure 8. Glass plates which together form the stimulus shown in Figure 7. Ruled regions are opaque.

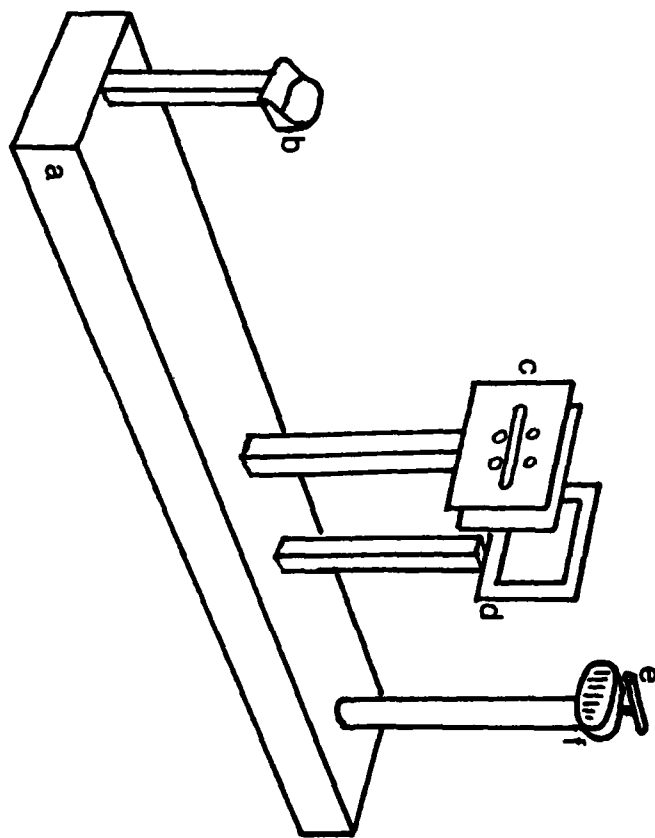

Figure 9. Apparatus for producing a stereoscopic after-image: a = optic bench; b = chin rest; c = target; d = diffusing and reduction screen; e = small dim light source; f = flashgun.

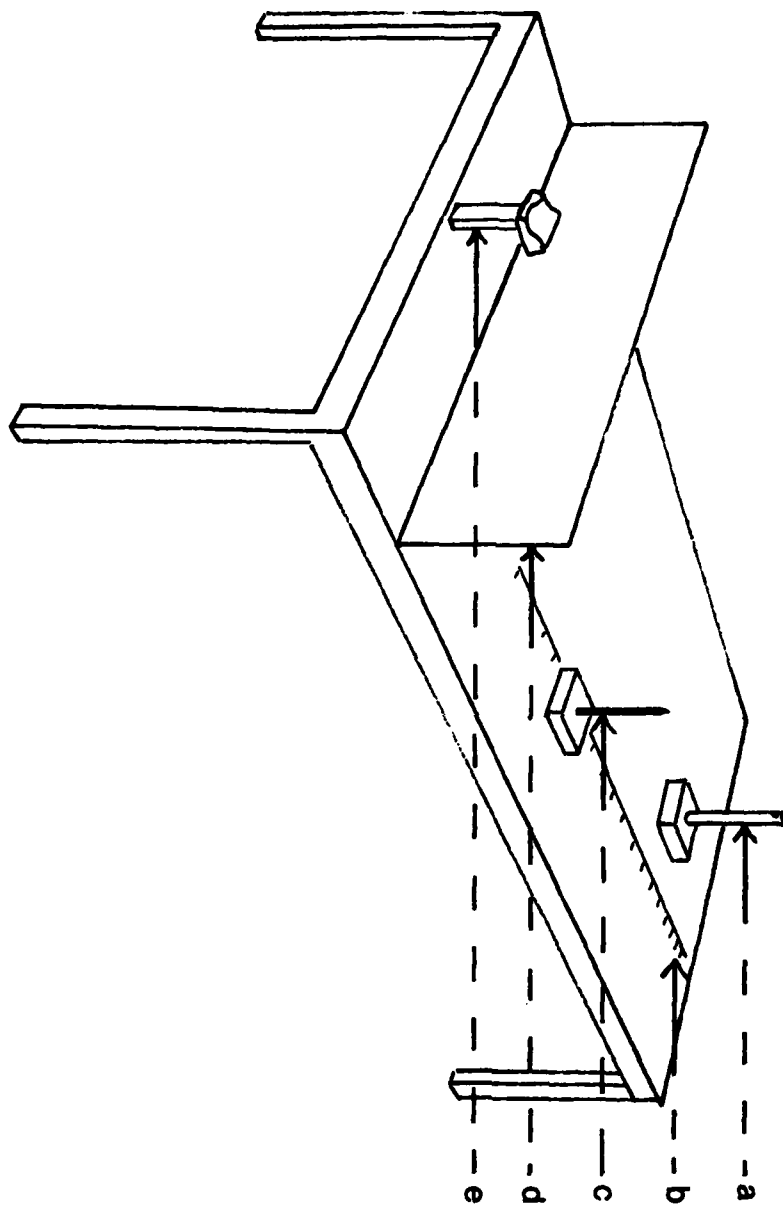

Figure 10. Test apparatus for measuring depth in after-images: a = fixation rod; b = scale; c = depth probe; d = occluding screen; e = chin rest.

visibility.

For longer test distances (>450 cm) a different arrangement was necessary. Near one end of a 30 m hallway (1.7 m wide x 2.3 m high) was suspended a white sheet illuminated by a Data Display Systems strobe (model 1091) flashing at ~ 5 Hz. One meter in front of this sheet was a chair on which was mounted a 6 cm wide black cardboard vertical strip with a white square (4 cm^2) fixation point 1.5 m from the floor. A meter stick with a 25 cm x 5 cm black and white striped ~~target~~ held by the experimenter served as the depth probe. Both the room and hallway were rich in depth cues: cement block walls, ceiling tiles, light fixtures, doors, and the like.

Observers

Three males and two females served as observers. Four were experienced psychophysical observers (faculty and graduate students) who were knowledgeable about stereopsis and afterimages. One observer was naive concerning the concepts underlying the experiment and inexperienced as a psychophysical observer. All scored in the normal range for stereopsis on the Orthorater and the Julesz random element stereogram series (Julesz, 1971). All had visual acuity at or corrected to 20/20. Observers who wore glasses normally used them during the experiment. Not all observers participated in all trials.

Procedure

Observers were tested individually. Before each trial the observer dark-adapted for at least two minutes, and then placed his or her chin in a head rest with head stabilizer. The small dim light above the flashgun allowed the observer to see the target clearly. When good fixation on

the 1 mm square fixation point was achieved, the observer depressed a push button which triggered the flashgun. This same push button also initiated the 5 hz flashing light which helped maintain afterimage visibility. The appearance of the afterimage with the circles floating in space in front of the fixation rod is simulated in Fig. 11. Then the observer fixated the test fixation point and directed the experimenter to move the depth probe nearer or farther away until it appeared to be in the depth plane of the circles.

For short inspection distances (≤ 450 cm) the observer had only to turn 90° from the inspection figure and place his or her chin on the chin rest at the end of the test table (see Fig. 10). For larger inspection distances the observer instead stepped out into the hallway and walked to a spot, marked by the experimenter, at a predetermined distance from the fixation rod at the end of the hall. In this case the experimenter walked backward or forward along the side of the hallway under the direction of the observer, until the observer judged that the depth probe held by the experimenter was in the plane of the afterimage.

Great care was taken to insure that a good afterimage was obtained. If the flashgun happened to be triggered when the eyes were moving or when they were not pointed directly at the fixation point, erroneous judgements could result. Observers were cautioned to obtain good fixation before triggering the flashgun. In addition, a second check on the quality of the afterimage was made by asking observers if the afterimage of the fixation point and horizontal bar appeared in the plane of the test fixation point. Often it was not, indicating the presence of fixation disparity or some other anomaly during the flash. Whenever the

Observer

Afterimage
in Depth

Fixation

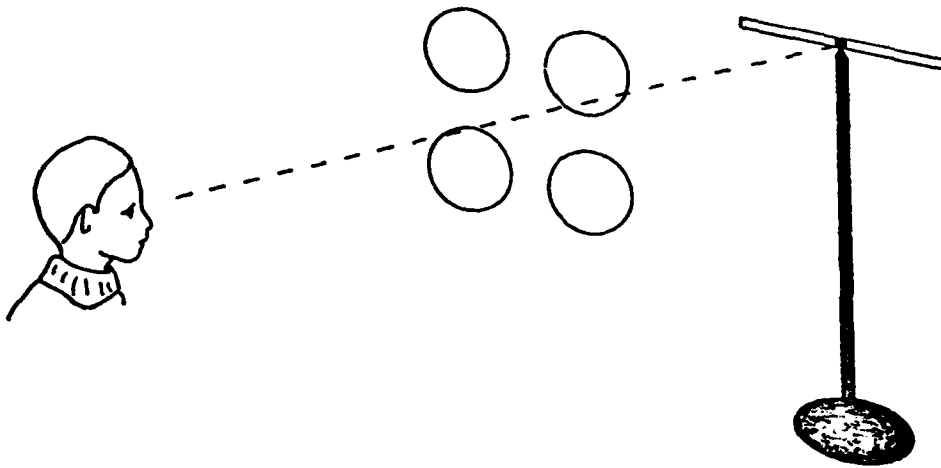

Figure 11. Appearance of afterimage with circles in crossed disparity.

observer was unable to see the afterimage fixation point in the plane of the test fixation point, the trial was aborted.

All observers were given at least one hour of practice before data were collected. Usually with practice, observers could make judgements rapidly enough to make two judgements before the afterimage faded significantly. They were urged not to try to make judgements if the afterimage was not clear. Inter-trial intervals varied but were always sufficient to allow the afterimage to fade beyond detectability. Experimental sessions were always less than 1 hour and no person participated in more than two sessions per day. For the main experiment two I-figs. were employed. For one the circles were .88 cm in front of the fixation point, which was 35 cm from the observer. This yielded $\approx 16.3'$ crossed retinal disparity. The other presented $\approx 4.5'$ of disparity by placing the circles .5 cm in front of the fixation point, which was 50 cm from the observer. The disparities are approximate because interpupillary distances vary from observer to observer.

Four observers made 8 depth judgements at each of 12 test fixation distances ranging from 1 to 27 meters for each I-fig. Test distances were randomized across trials for each observer; ascending and descending trials were counterbalanced. The 450 cm test distance was employed for both test conditions (in the small room and in the hall) to check for consistency. Trials in which the observer occluded one eye before triggering the flash-gun provided monocular control.

Results

The curves in Fig. 12 give the predicted depth values as a function of fixation distance (log units) for the two values of retinal disparity

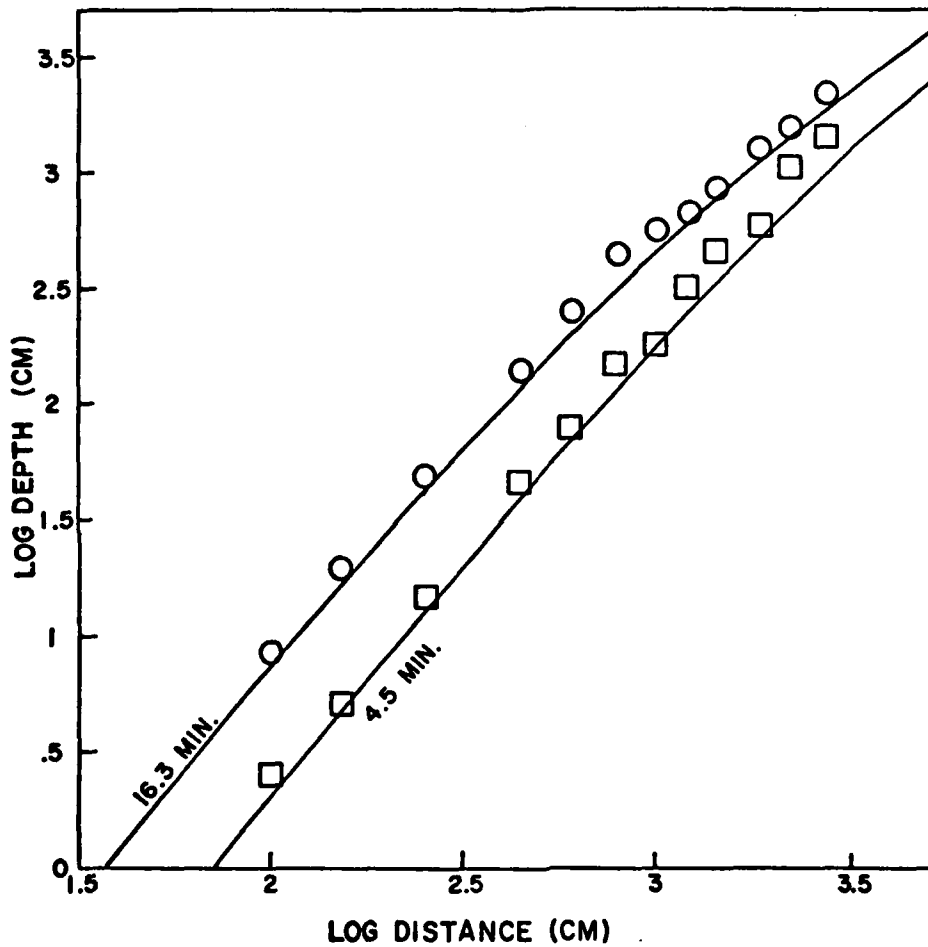

Figure 12. Apparent depth in a stereoscopic afterimage as a function of fixation distance for crossed retinal disparities of 4.5 and 16.3 min. Curves represent predicted values. Data points are based on 8 trials for each of four observers. Standard errors across observers averaged 6.5% (range 3.7 to 11.0) of mean apparent depth.

used in the experiment. The circles and squares give the obtained depth intervals for the fixation distances employed. Each data point represents the mean of eight trials for each of four observers. The standard errors across observers ranged from 3.7 to 11 per cent of the mean apparent depth and averaged 6.5 per cent. Thus, variability increased consistently with fixation distance and/or apparent depth. The results from the naive observer did not differ in any systematic way from those from the experienced observers.

The main point illustrated in Fig. 12 is the close agreement between the predicted and obtained values. Except for the two largest depth values in the 4.5' disparity condition all the data points are very close to the predicted curves. Clearly perceived depth in stereoscopic afterimages grows as expected according to the geometry of stereopsis.

It will be noticed that there is a consistent tendency for the obtained values to exceed the predicted values. In other words, the observers reliably reported greater depth than the theory would predict. One possible explanation for this may be found in a difficulty observers experienced in performing the task. This difficulty is analogous to the situation which occurs when one attempts to look at a conventional afterimage which is not centered in the visual field. Each eye movement, of course, moves the afterimage and one finds oneself pursuing the afterimage like a dog chasing its own tail.

In the present experiment, observers were concentrating on an image closer than the fixation plane and found themselves trying to fixate on this nearer plane rather than the fixation point provided. This attempt merely moved the afterimage of the circles even nearer, thereby triggering

greater fixation attempts. The result was a zooming effect in which the afterimage moved nearer and nearer. This can only be prevented by firmly keeping fixation on the test fixation point. Observers reported that they had to constantly remind themselves to do this.

Of special interest relative to these data is the dramatic magnification of apparent depth which is not immediately apparent in Fig. 12. For 16.3' of retinal disparity the depth in the I-fig. was only .88 cm at a viewing distance of 35 cm. The depth was only 2.5% of the viewing distance. At a fixation distance of 14 meters the afterimage appeared halfway between the fixation point and the observer, i.e., the apparent depth was 50% of the viewing distance. At 27 meters, the greatest used, the circles appeared to be almost 22 meters in front of fixation, that is, the apparent depth was 22 meters, over 80% of the fixation distance. By contrast, if depth increased linearly with fixation distance, the apparent depth at 27 meters would be a mere 68 cm.

All observers reported that the appearance of the afterimage agreed with the depth probe matches. That is, they agreed that at 27 meters fixation distance, the circles seemed to be floating in space about 5 to 8 meters away from themselves. They reported noticing the dramatic shrinking of the depth as they walked down the hallway while looking at the fixation object. These observations are important for they demonstrate that the observers were not merely making disparity matches between the depth probe and the circles but that the depth probe settings reflected the apparent position of the disparate circles.

Additional Observations

In this section I will describe the results of a small experiment using stereoscopic afterimages with uncrossed disparity, some observations

made using a variety of different stereoscopic afterimages and some problems associated with the use of stereoscopic afterimages.

The main experiment was confined to afterimages with crossed disparity, the disparate object was nearer the observer than the fixation point. In two separate series of trials, perceived depth in a stereoscopic afterimage as a function of viewing distance was measured for 15.5' uncrossed disparity. The experimental procedure was identical to that described earlier. The I-fig was the same except that the fixation point was .88 cm in front of the circles and was viewed at 3.5 cm. This produced about 16' of disparity. Measures were made at test distances of 75, 150 and 350 cm. All measures used the test apparatus shown in Fig. 11. Four observers made 8 judgements, each for all three test distances. The mean apparent depths were 3.6 cm at 75 cm; 12.3 cm at 150 cm; and 61.7 cm at 350 cm. The predicted values for these fixation distances are 4.07, 17.18 and 110.3 respectively. The agreement with predictions is not as close as was obtained for crossed disparity but follows the same pattern. All observers agreed that the uncrossed condition was more difficult. In fact, one observer could not perform the task in the uncrossed condition because for her the afterimage of the circles always appeared to be on the wall behind the fixation point.

Several observations were made using an inspection figure containing both crossed and uncrossed disparity. The I-fig had the same configuration as Fig. 7 but the two upper circles were .5 cm behind the fixation point while the lower circles were .5 cm in front of fixation. No measures were taken using the depth probe. All observers (4) agreed that in the afterimage the upper circles appeared in front of fixation and the lower circles

appeared behind fixation. They also reported that the depth intervals appeared to be about the same as those seen with I-figs containing only one disparity.

Another interesting observation involved the afterimage of a skeletal cube. The wire outline of a cube was mounted in place at the I-fig in front of the diffusing screen (see Fig. 9). When the flashgun was triggered, observers reported a clear afterimage of a cube with very realistic depth. We expected that if this were viewed at a larger fixation distance the cube would appear distorted. The reasoning was that the size of the cube orthogonal to the line of sight should grow linearly with distance but its depth defined by disparity should grow approximately with the square of the distance. This did not occur. All observers (6) reported that the cube remained an undistorted cube at all fixation distances. It did grow in overall size but retained its integrity as a cube. Perhaps other depth cues overwhelmed disparity, or perhaps the observers' knowledge of, or familiarity with the cube, resisted distortion.

Workers using stereoscopic afterimages should be made aware of a couple of potential problems. My first attempts to obtain and measure depth in stereoscopic afterimages failed. The test fixation point for these early attempts was a small dot on the wall. Under this condition there is a strong tendency for the whole afterimage to appear to be on the wall. For fleeting intervals it may stand out, but most of the time it appears in the plane of the wall. It is possible that some sort of equidistance tendency is operating under this condition (Gogel, 1965). In any case it appears important to provide a fixation point out in space, away from a surface.

It is also important to keep critical parts of the afterimage close to the center of the visual field. Observers found it much easier to make depth judgements for circles close to fixation. In some early I-figures the four circles were more widely spread out. Judgements were much more variable and observers complained about the difficulty of the task.

Discussion

In this section I shall discuss stereoscopic depth constancy and show how the results of the present study relate to this concept and to theories regarding it.

Depth constancy refers to the notion that depth intervals appear to remain the same or constant with changes in viewing distance. For example, suppose an observer judges one object to be 5 meters away and another to be 6 meters away in the same direction. Obviously, the two objects are separated in depth by 1 meter. The observer backs away 10 meters. If perfect depth constancy is obtained the observer would still judge the two objects to be separated in depth by 1 meter.

Stereoscopic depth constancy is a more limited version of the same concept. It refers to the judgement of depth intervals mediated or signaled by retinal disparity. Thus, if two objects are separated in depth and the only cue to the depth interval is retinal disparity, will this depth interval remain phenomenally constant with changes in viewing distance? If it does, then stereoscopic depth constancy has occurred.

Any complete theory of stereoscopic depth constancy must show how retinal disparity is recalibrated so as to signal different depth intervals at different apparent egocentric distances. In general, such theories

would first seek to identify the source of information used to judge viewing distance and, second, state the rule and/or mechanism by which retinal disparity is rescaled as a function of apparent viewing distance. Of the theories discussed by Ono and Comerford, some address the first point, some the second, while very few address both.

Let us look first at the question of the information used by the observer to judge viewing distance or rescale disparity. Three different hypotheses have been popular. One suggests that oculomotor cues provide the needed information (Richards, 1967). The rescaling of disparity could be a one- or two-stage process. In the one case, disparity could be rescaled directly by convergence. In the other, convergence could be used to judge absolute distance, which in turn would be used to rescale disparity. In either case, convergence provides the necessary information. Convergence and accommodation can provide direct information about absolute egocentric distance, but only at short distances. Thus if depth constancy holds only at short distances this theory gains support.

As mentioned above, Ono and Comerford (1977) have reviewed studies of depth constancy and have concluded that stereoscopic depth constancy holds only at short (≈ 200 cm) viewing distances. This conclusion, if valid, would support oculomotor theories of depth constancy.

Another view suggests that perceived size is the critical cue. As with oculomotor cues, perceived size might be used directly (with retinal angle) to rescale disparity or might instead serve as a cue to viewing distance which would then be used to rescale distance. Gogel (1960) has presented data which show the importance of perceived size in depth judgments.

A third view is that disparity is rescaled on the basis of perceived distance and that any cues which provide egocentric distance information affect disparity scaling (Foley, 1978). According to this view, oculomotor cues might play a part in depth constancy at small fixation distances but not at greater ones. Familiar size, perspective, motion parallax and all the other sources of distance information could contribute to apparent distance which would then be used to calibrate retinal disparity.

It is worth considering the possibility that depth intervals may not be the primary output of retinal disparity processing. An alternative is that retinal disparity in conjunction with apparent distance yields directly an egocentric distance for disparate objects. The depth interval would then be a derivative judgement made by comparing the egocentric distances of the fixated point and the disparate point (or for that matter, two different disparate points).

Turning now to the rule by which disparity is calibrated, we find several alternatives. The simplest rule says that disparity is not rescaled. That is, a given disparity always signals the same depth interval. No more need be said about this, other than to point out that a myriad of studies, in addition to the present one, have demonstrated that perceived depth does change without changes in disparity (Ono & Comerford, 1977).

The most-oft stated rule for scaling disparity is the distance squared rule. This rule, which dates back at least to Von Kries (1866), and championed more recently by Wallach and Zuckerman (1963), is based on the inverse square law. The inverse square law states that the retinal disparity produced by a given depth interval decreases as the square of fixation

distance. This law is a simplification of the geometry of retinal disparity and provides a good approximation to it under certain conditions. However, a consideration of this rule as applied to afterimages shows that it cannot possibly hold at extreme conditions. Consider Figure 12. At 27 meters the inverse square law would give a depth interval value for 16.3' crossed disparity of over 52 meters. This places the afterimage \approx 25 meters behind the head of the observer: Obviously this cannot happen. The data for the 16.3' condition deviate considerably from a prediction based on the inverse square law. The data from the 4.5' condition fit an inverse square law about as well as they fit the curve shown, but with only 4.5' of disparity the difference between the inverse square law and the curve given is not great for the range of values used.

In summary, I conclude that depth constancy is a real phenomenon and holds for a wide range of apparent distances (at least up to 27 meters). I conclude further that whatever cues are used to scale retinal disparity, they involve more than oculomotor cues, and that the rule by which retinal disparity is recalibrated is in accord with the geometry describing retinal disparity and stereopsis. This rule is closely approximated by the inverse distance square rule only for small disparities and short viewing distances.

REFERENCES

- Foley, J.M. Primary distance perception. In R. Held, H. Leibowitz, & H.-L. Teuber (Eds.), Handbook of Sensory Physiology, Vol. 8. Berlin: Springer-Verlag, 1978.
- Gogel, W.C. Equidistance tendency and its consequences. Psychological Bulletin, 1965, 64, 153-163.
- Gogel, W.C. Perceived frontal size as a determiner of perceived binocular depth. Journal of Psychology, 1960, 50, 119-131.
- Helmholtz, H. von. Handbook of Physiological Optics (J.P.C. Southall, editor and translator). New York: Dover, 1962 (originally published 1866).
- Kries, J. von. Notes on perception of depth. In H. von Helmholtz (Ed.), Handbook of Physiological Optics, Vol. 3 (J.P.C. Southall, editor and translator). New York: Dover, 1962 (originally published 1866).
- Ono, H., & Comerford, T. Stereoscopic depth constancy. In W. Epstein (Ed.), Stability and Constancy in Visual Perception: Mechanisms and Processes.
- Richards, W. Apparent modifiability of receptive fields during accommodation and convergence and a model for size constancy. Neuropsychologia, 1967, 5, 63-72.
- Wallach, H., & Zuckerman, C. The constancy of stereoscopic depth. The American Journal of Psychology, 1963, 76, 404-412.
- Wheatstone, C. On some remarkable and hitherto unobserved phenomena of binocular vision. London Society of Philosophy Transactions, 1938, 394.

OFFICE OF NAVAL RESEARCH

Code 442

TECHNICAL REPORTS DISTRIBUTION LIST

OSD

CDR Paul R. Chatelier
Office of the Deputy Under Secretary
of Defense
OUSDRE (E&LS)
Pentagon, Room 3D129
Washington, D.C. 20301

Department of the Navy

Engineering Psychology Programs
Code 442
Office of Naval Research
800 North Quincy Street
Arlington, VA 22217 (5 cys)

Communication & Computer Technology
Programs
Code 240
Office of Naval Research
800 North Quincy Street
Arlington, VA 22217

Manpower, Personnel and Training
Programs
Code 270
Office of Naval Research
800 North Quincy Street
Arlington, VA 22217

Statistics and Probability Program
Code 411-S&P
Office of Naval Research
800 North Quincy Street
Arlington, VA 22217

Information Systems Program
Code 433
Office of Naval Research
800 North Quincy Street
Arlington, VA 22217

Department of the Navy

Physiology & Neuro Biology Program
Code 441B
Office of Naval Research
800 North Quincy Street
Arlington, VA 22217

Special Assistant for Marine
Corps Matters
Code 100M
Office of Naval Research
800 North Quincy Street
Arlington, VA 22217

Commanding Officer
ONR Eastern/Central Regional Office
ATTN: Dr. J. Lester
Barnes Bldg.
495 Summer St.
Boston, MA 02210

Commanding Officer
ONR Branch Office
ATTN: Dr. C. Davis
1030 East Green St.
Pasadena, CA 91106

Commanding Officer
ONR Western Regional Office
ATTN: Dr. E. Gloye
1030 East Green Street
Pasadena, CA 91106

Office of Naval Research
Scientific Liaison Group
American Embassy, Room A-407
APO San Francisco, CA 96503

Director
Naval Research Laboratory
Technical Information Division
Code 2627
Washington, D.C. 20375 (6 cys)

Department of the Navy

Dr. Robert G. Smith
Office of the Chief of Naval
Operations, OP987H
Personnel Logistics Plans
Washington, D.C. 20350

Dr. Jerry C. Lamb
Combat Control Systems
Naval Underwater Systems Center
Newport, RI 02840

Naval Training Equipment Center
ATTN: Technical Library
Orlando, FL 32813

Human Factors Department
Code N215
Naval Training Equipment Center
Orlando, FL 32813

Dr. Stanley C. Collyer
Code N-732
Naval Training Equipment Center
Orlando, FL 32813

Dr. Alfred F. Smode
Training Analysis and Evaluation
Group
Naval Training Equipment Center
Code N-00T
Orlando, FL 32813

Dr. Albert Colella
Combat Control Systems
Naval Underwater Systems Center
Newport, RI 02840

Dr. Gary Poock
Operations Research Department
Naval Postgraduate School
Monterey, CA 93940

Dean of Research Administration
Naval Postgraduate School
Monterey, CA 93940

Mr. Paul Heckman
Naval Ocean Systems Center
San Diego, CA 92152

Mr. Warren Lewis
Human Engineering Branch
Code 8231
Naval Ocean Systems Center
San Diego, CA 92152

Dr. John Silva
Naval Ocean Systems Center
San Diego, CA 92152

Dr. Ross L. Pepper
Naval Ocean Systems Center
Hawaii Laboratory
P.O. Box 997
Kailua, HI 96734

Dr. A.L. Slafkosky
Scientific Advisor
Commandant of the Marine Corps
Code RD-1
Washington, D.C. 20380

Mr. Arnold Rubinstein
Naval Material Command
NAVMAT 0722 - Rm. 508
800 North Quincy Street
Arlington, VA 22217

Commander
Naval Air Systems Command
Human Factors Programs
NAVAIR 340F
Washington, D.C. 20361

Commander
Naval Air Systems Command
Crew Station Design,
NAVAIR 5313
Washington, D.C. 20361

Mr. Phillip Andrews
Naval Sea Systems Command
NAVSEA 0341
Washington, D.C. 20362

Commander
Naval Electronics Systems Command
Human Factors Engineering Branch
Code 4701
Washington, D.C. 20360

CDR Robert Biersner
Naval Medical R&D Command
Code 44
Naval Medical Center
Bethesda, MD 20014

Department of the Navy

Dr. Arthur Bachrach
Behavioral Sciences Department
Naval Medical Research Institute
Bethesda, MD 20014

Dr. George Moeller
Human Factors Engineering Branch
Submarine Medical Research Lab
Naval Submarine Base
Groton, CT 06340

Head
Aerospace Psychology Department
Code L5
Naval Aerospace Medical Research Lab
Pensacola, FL 32508

Dr. James McGrath
CINCLANT FLT HQS
Code 04E1
Norfolk, VA 23511

Dr. Robert Blanchard
Navy Personnel Research and
Development Center
Command and Support Systems, Code 304
San Diego, CA 92152

Dr. Julie Hopson
Human Factors Engineering Division
Naval Air Development Center
Warminster, PA 18974

Mr. Jeffrey Grossman
Human Factors Branch
Code 3152
Naval Weapons Center
China Lake, CA 93555

Human Factors Engineering Branch
Code 1226
Pacific Missile Test Center
Point Mugu, CA 93042

Mr. J. Williams
Department of Environmental
Sciences
U.S. Naval Academy
Annapolis, MD 21402

Department of the Navy

Human Factors Section
Systems Engineering Test
Directorate
U.S. Naval Air Test Center
Patuxent River, MD 20670

Human Factor Engineering Branch
Naval Ship Research and Development
Center, Annapolis Division
Annapolis, MD 21402

CDR W. Moroney
Code 55MP
Naval Postgraduate School
Monterey, CA 93940

Department of the Army

Mr. J. Barber
HQS, Department of the Army
DAPE-MBR
Washington, D.C. 20310

Dr. Joseph Zeidner
Technical Director
U.S. Army Research Institute
5001 Eisenhower Avenue
Alexandria, VA 22333

Director, Organizations and
Systems Research Laboratory
U.S. Army Research Institute
5001 Eisenhower Avenue
Alexandria, VA 22333

Technical Director
U.S. Army Human Engineering Labs
Aberdeen Proving Ground, MD 21005

ARI Field Unit-USAREUR
ATTN: Library
C/O ODCSPER
HQ USAREUR & 7th Army
APO New York 09403

Department of the Air Force

U.S. Air Force Office of Scientific
Research
Life Sciences Directorate, NL
Bolling Air Force Base
Washington, D.C. 20332

Chief, Systems Engineering Branch
Human Engineering Division
USAF AMRL/HES
Wright-Patterson AFB, OH 45433

Air University Library
Maxwell Air Force Base, AL 36112

Dr. Earl Alluisi
Chief Scientist
AFHRL/CCN
Brooks AFB, TX 78235

Foreign Addressees

Director, Human Factors Wing
Defence & Civil Institute of
Environmental Medicine
Post Office Box 2000
Downsview, Ontario M3M 3B9
CANADA

Dr. A. D. Baddeley
Director, Applied Psychology Unit
Medical Research Council
15 Chaucer Road
Cambridge, CB2 2EF
ENGLAND

Other Government Agencies

Defense Technical Information Center
Cameron Station, Bldg. 5
Alexandria, VA 22314 (12 cys)

Dr. Craig Fields
Director, System Sciences Office
Defense Advanced Research Projects
Agency
1400 Wilson Blvd
Arlington, VA 22209

Other Government Agencies

Dr. Lloyd Hitchcock
Federal Aviation Administration
ACT 200
Atlantic City Airport, NJ 08405

Dr. M. Montemerlo
Human Factors & Simulation
Technology, RTE-6
NASA HQS
Washington, D.C. 20546

Other Organizations

Dr. Jesse Orlansky
Institute for Defense Analyses
400 Army-Navy Drive
Arlington, VA 22202

Dr. T. B. Sheridan
Department of Mechanical Engineering
Massachusetts Institute of Technology
Cambridge, MA 02139

Dr. Arthur I. Siegel
Applied Psychological Services, Inc.
404 East Lancaster Street
Wayne, PA 19087

Dr. Harry Snyder
Department of Industrial Engineering
Virginia Polytechnic Institute and
State University
Blacksburg, VA 24061

Dr. W. S. Vaughan
Oceanautics, Inc.
422 6th Street
Annapolis, MD 21403

Dr. Robert T. Hennessy
NAS - National Research Council
2101 Constitution Ave., N.W.
Washington, DC 20418

Dr. M. G. Samet
Perceptronic, Inc.
6271 Variel Avenue
Woodland Hills, CA 91364

Other Organizations

Dr. Robert Williges
Human Factors Laboratory
Virginia Polytechnic Institute
and State University
130 Whittemore Hall
Blacksburg, VA 24061

Dr. William R. Uttal
Institute for Social Research
University of Michigan
Ann Arbor, MI 48109

Dr. Alphonse Chapanis
Department of Psychology
The Johns Hopkins University
Charles and 34th Streets
Baltimore, MD 21218

Journal Supplement Abstract Service
American Psychological Association
1200 17th Street, N.W.
Washington, D.C. 20036 (3 cys)

Dr. Christopher Wickens
University of Illinois
Department of Psychology
Urbana, IL 61801

Dr. Babur M. Pulat
Department of Industrial Engineering
North Carolina A&T State University
Greensboro, NC 27411

Dr. Richard W. Pew
Information Sciences Division
Bolt Beranek & Newman, Inc.
50 Moulton Street
Cambridge, MA 02238

Dr. David J. Getty
Bolt Beranek & Newman, Inc.
50 Moulton Street
Cambridge, MA 02238

Dr. Douglas Towne
University of Southern California
Behavioral Technology Laboratory
3716 S. Hope Street
Los Angeles, CA 90067

Dr. Stanley N. Roscoe
New Mexico State University
Box 5095
Las Cruces, NM 88003

**DAT
ILM**