

MICROCOPY RESOLUTION TEST CHART

AD A111514

5

HDL-SR-81-8
December 1981

Improved Design AURORA Modification Program (IDAMP)

by Stewart E. Graybill
George A. Huttlin
Klaus G. Kerris
Alexander G. Stewart
Denis A. Whittaker

DTIC
SELECTED
MAR 3 1982
S A D



This project was sponsored by the
Defense Nuclear Agency under subtask
IAXYX, work unit 00001, AURORA Operations.

U.S. Army Electronics Research
and Development Command
Harry Diamond Laboratories
Adelphi, MD 20783

Approved for public release; distribution unlimited.

82 03 02 035

AD A111514

The findings in this report are not to be construed as an official Department of the Army position unless so designated by other authorized documents.

Citation of manufacturers' or trade names does not constitute an official indorsement or approval of the use thereof.

Destroy this report when it is no longer needed. Do not return it to the originator.

UNCLASSIFIED

SECURITY CLASSIFICATION OF THIS PAGE (When Data Entered)

REPORT DOCUMENTATION PAGE		READ INSTRUCTIONS BEFORE COMPLETING FORM
1. REPORT NUMBER HDL-SR-81-8	2. GOVT ACCESSION NO. AD-4111514	3. RECIPIENT'S CATALOG NUMBER
4. TITLE (and Subtitle) Improved Design AURORA Modification Program (IDAMP)		5. TYPE OF REPORT & PERIOD COVERED Special Report
		6. PERFORMING ORG. REPORT NUMBER
7. AUTHOR(s) Stewart E. Graybill Alexander G. Stewart George A. Huttlin Denis A. Whittaker Klaus G. Kerris		8. CONTRACT OR GRANT NUMBER(s)
9. PERFORMING ORGANIZATION NAME AND ADDRESS Harry Diamond Laboratories 2800 Powder Mill Road Adelphi, MD 20783		7. PROGRAM ELEMENT, PROJECT, TASK AREA & WORK UNIT NUMBERS Program Ele.: 6.27.15.H
11. CONTROLLING OFFICE NAME AND ADDRESS Director Defense Nuclear Agency Washington, DC 20305		12. REPORT DATE December 1981
		13. NUMBER OF PAGES 28
14. MONITORING AGENCY NAME & ADDRESS (if different from Controlling Office)		15. SECURITY CLASS. (of this report) UNCLASSIFIED
		15a. DECLASSIFICATION/DOWNGRADING SCHEDULE
16. DISTRIBUTION STATEMENT (of this Report) Approved for public release; distribution unlimited.		
17. DISTRIBUTION STATEMENT (of the abstract entered in Block 20, if different from Report)		
18. SUPPLEMENTARY NOTES HDL Project: 201124 MIPR: 81-559 This project was sponsored by the Defense Nuclear Agency under sub-task IAXYX, work unit 00001, AURORA Operations.		
19. KEY WORDS (Continue on reverse side if necessary and identify by block number) AURORA Pulsed power High-intensity electron beam High-intensity ion beam Microwave source Gamma source SREMP simulator Source-region electromagnetic pulse		
20. ABSTRACT (Continue on reverse side if necessary and identify by block number) The AURORA High-Intensity Flash Ray Facility could be modified to provide a high-energy, medium (2 to 10 Ω) impedance, multiterawatt pulse power source. This Improved Design AURORA Modification Program (IDAMP) could be achieved with only modest restructuring of the existing AMP water-insulated pulser. Transformer oil, rather than deionized water, would be the insulating medium. A power output of >5 TW in a pulse of <5 MV amplitude and		

DD FORM 1 JAN 73 1473

EDITION OF 1 NOV 65 IS OBSOLETE

UNCLASSIFIED

1 SECURITY CLASSIFICATION OF THIS PAGE (When Data Entered)

UNCLASSIFIED

SECURITY CLASSIFICATION OF THIS PAGE(When Data Entered)

20. ABSTRACT (cont'd)

> =140 ns FWHM is feasible in either positive or negative polarity. This power source could be applied to high-intensity electron, ion, and microwave beams.

Handwritten notes and a large handwritten letter 'A' are present in the lower-left quadrant of the page.

DTIC
COPY
INSPECTED
2

UNCLASSIFIED

2 SECURITY CLASSIFICATION OF THIS PAGE(When Data Entered)

CONTENTS

	<u>Page</u>
1. INTRODUCTION	5
2. PHYSICAL DESCRIPTION OF PROPOSED IDAMP LINE MODIFICATION	8
3. POWER FLOW ANALYSIS	11
3.1 Circuit	11
3.2 Pulse-Forming Line	19
3.3 Diode	19
4. APPLICATIONS	20
4.1 Ion Diode	20
4.2 Thermal Structures Response	20
4.3 Radiation Effects	21
4.4 Source-Region Electromagnetic Pulse	21
4.5 Microwaves	22
5. AURORA FACILITY MODIFICATIONS FOR IDAMP	22
6. CONCLUSIONS AND RECOMMENDATIONS	22
DISTRIBUTION	25

FIGURES

1. Final design configuration of AMP	6
2. IDAMP: proposed design configuration and simplified equivalent circuit	7
3. Existing AMP front end	9
4. Front end modifications for IDAMP	10
5. Comparison of IDAMP front end with existing AMP front end	11
6. IDAMP circuit schematic diagram used for preliminary analysis	13
7. Calculated voltage and energy flow at 90-kV Marx charge with 5- Ω load	15
8. Calculated voltage and energy flow at 105-kV Marx charge with 3.5- Ω load	17

1. INTRODUCTION

There is a growing requirement for multiterawatt power sources with bimodal polarity and variable output-voltage profiles into load impedances in the 2- to 10- Ω range. Variable pulse durations up to 150 ns with very fast rise times (<20 ns) also are needed. Typical of the applications that can be considered within these parameter regimes are (1) high-intensity, fast rise γ simulators for source-region electromagnetic pulse (SREMP) investigations, (2) large-area electron beams for thermal structural response studies, and (3) ion diodes for inertial-confinement fusion studies.

To meet these requirements, several proposals have been suggested by the Harry Diamond Laboratories (HDL) for modifying the existing AURORA High-Intensity Flash X-Ray Facility. One proposal is that, in each of the AURORA Blumleins, the intermediate cylinder be electrically tied to the corresponding inner cylinder at its output end, thus reducing each Blumlein to a simple 8.5- Ω line source. With a new and suitable switch between these lines and the high-voltage end of the insulator stack, these 8.5- Ω sources could deliver significantly more power into a low-impedance load than the existing AURORA in positive polarity. Disadvantages of this proposal are the high cost of the conversion and the adverse impact that it would have on normal AURORA operations.

Another proposal is to reestablish the AURORA Modification Program (AMP) as a subohm source. The conversion to the low-impedance mode would be accomplished by the addition of a water-insulated pulse-forming network attached to the Marx output (fig. 1). Apart from serious reservations about the cost of this program, it is technically very questionable whether ion diodes can be effectively designed to operate efficiently at the subohm level. Moreover, the problem of ensuring the complete integrity of the pulser against major oil and water spills is a very difficult one, given the complexity of operation of the existing differential-pressure control system and the vulnerability to rupture of the dielectric diaphragm and the prepulse suppression slab.

The Improved Design AURORA Modification Program (IDAMP) is a simple, effective alternative proposed to permit both of the prime objectives to be met: (1) It would operate as a multiterawatt power source in both positive and negative polarities with variable output-voltage profiles into 2- to 10- Ω load impedances. (2) It would operate that way with minimal cost and operational impact on present AURORA operations. For IDAMP, transformer oil is substituted for the water, and a new pulse-forming line (PFL) is created to replace much of the old internal AMP structure (fig. 2). Although water, as a dielectric medium, is superior to oil for low-impedance operation, oil is superior for the impedance regime of interest here, 2 to 5 Ω . Also, removing the rupturable diaphragm and prepulse slab virtually eliminates spill problems. These advantages are offered by IDAMP:

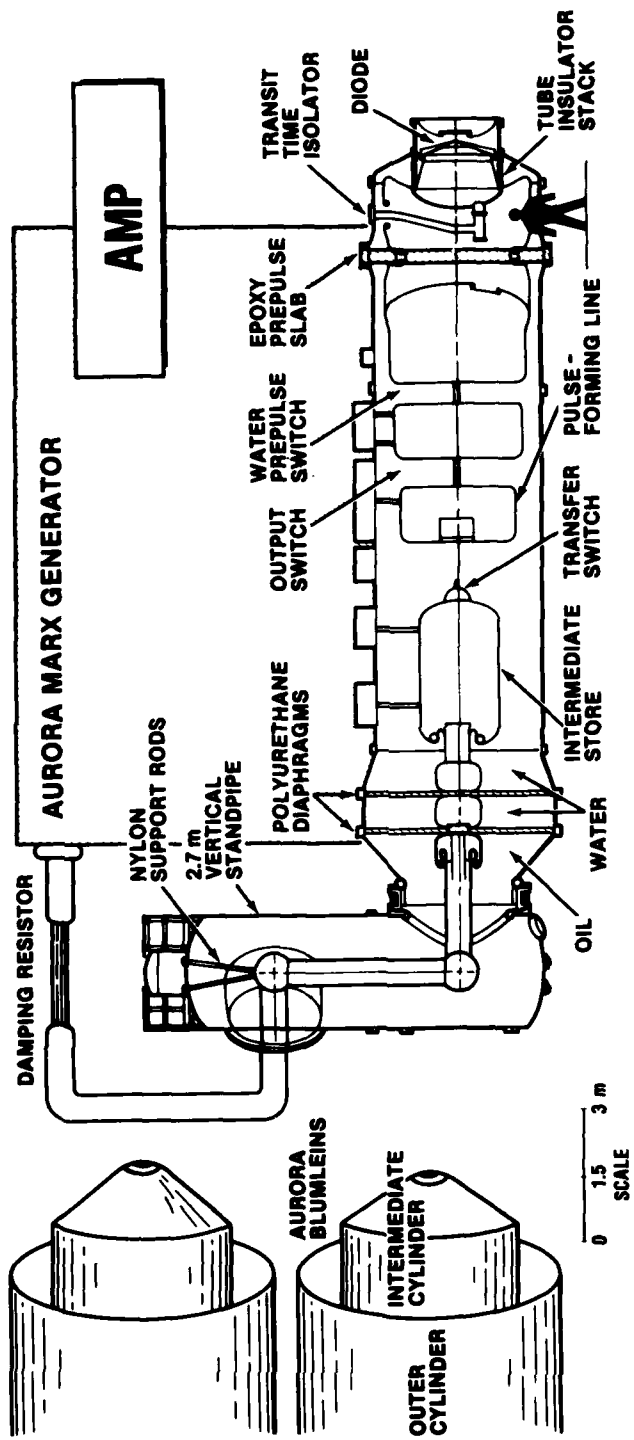

Figure 1. Final design configuration of AMP.

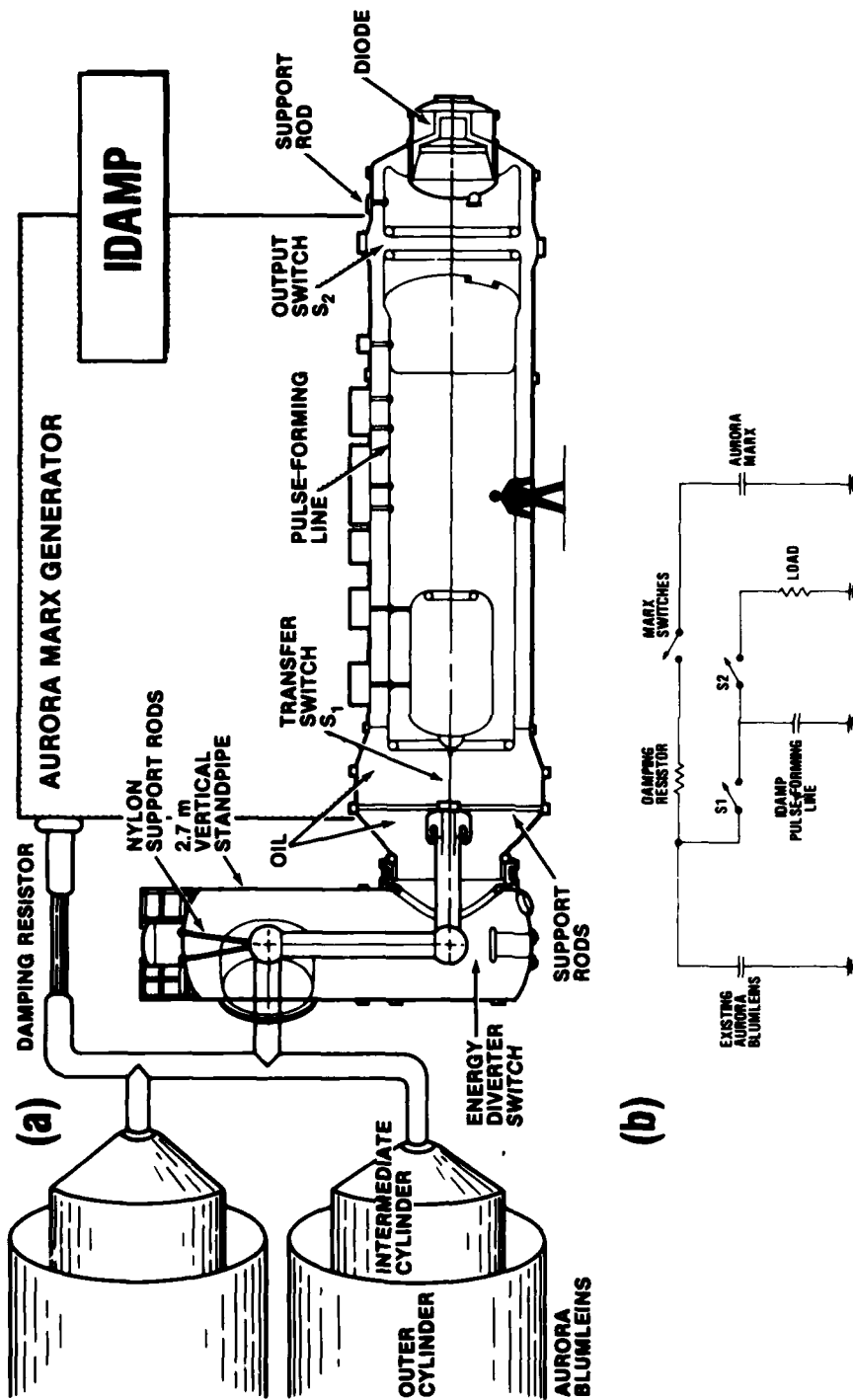

Figure 2. IDAMP: (a) proposed design configuration and (b) simplified equivalent circuit.

- The machine modifications and the experimental work can be performed off line with much less disruption to AURORA operations than would be associated with alternative in-line modifications.

- IDAMP can produce a power output of >5 TW at proven levels of AURORA positive-polarity operation. (Volume breakdown in the Blumleins has not been observed for Marx charge levels up to +110 kV.)

- Since there is only one input switch and one output switch, there is no need for high-resolution, high-reliability synchronization of switches within the pulser.

This alternative modification and its advantages are detailed in section 2.

2. PHYSICAL DESCRIPTION OF PROPOSED IDAMP LINE MODIFICATION

The AURORA Blumlein intermediate cylinders will be electrically tied together and their combined outputs will feed the center electrode of the 9-ft (2.7-m) vertical standpipe (fig. 2a). At the base of the standpipe, an energy diverter switch assembly will be installed to remove, if desired, the low-energy, late-time transients delivered by the Blumleins. The AMP intermediate store will be turned 180 deg and, nested inside, it will thus help support the new PFL, which now runs almost the entire length of the old AMP line. The input switch to this new line, S_1 , will be formed by the central conductor of the 2.7-m standpipe and the field-enhanced movable electrode on the intermediate store. At the other end of this new PFL, a switch set, S_2 , will take the place of the AMP prepulse slab. Some hardware modifications will be required to relocate the existing output switch hardware to these new switch sites, but no major restructuring of the hardware is anticipated. The transit time isolator (TTI), also, will need to be replaced by an inductive isolator; however, the existing TTI port can be effectively used for providing clearance for the rod that supports the final transformer line section. For positive-polarity operation, the tube insulator rings will need to be inverted for high flashover strength. For performance exceeding 5 MV, additional insulator stages will probably need to be added to the insulator stack. A simplified equivalent circuit for IDAMP is shown in figure 2(b).

Reconfiguring the vacuum feed region of the present AMP hardware should present no major problems. For $5\text{-}\Omega$ electron and ion-beam load impedances, the existing AMP front end (fig. 3), which had been designed for imploding plasma loads, requires these changes (fig. 4):

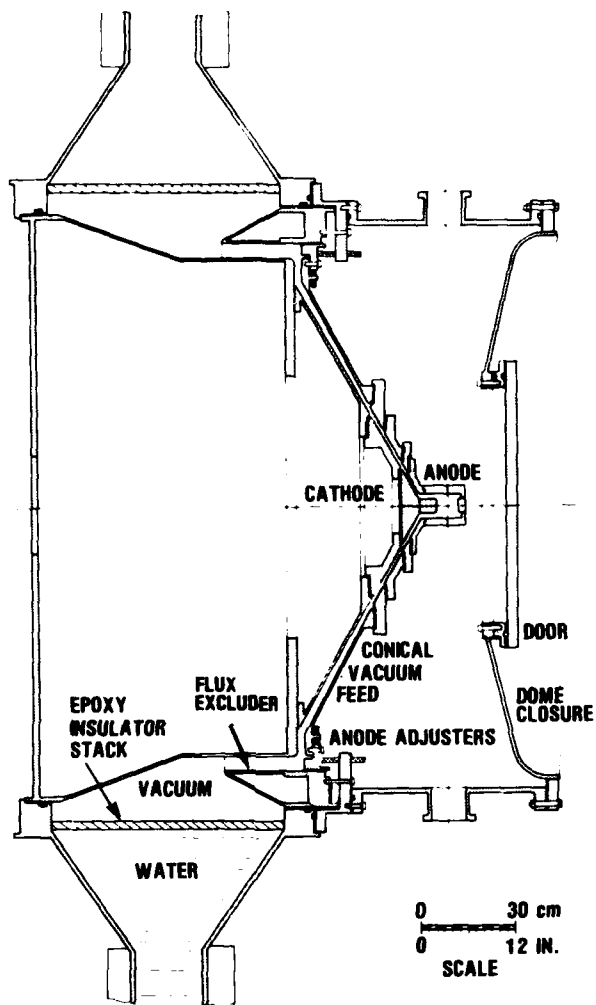

Figure 3. Existing AMP front end.

- Shorten the cathode support assembly 2 in. (5 cm) and adjust the anode cone to its extreme forward position to open up the anode-cathode (A-K) gap from 1 to 10 cm.
- Remove the flux excluder.
- Replace the conical imploding-plasma-load vacuum-feed section with a short 20- Ω vacuum coaxial feed section.
- Reverse the diagnostic-chamber dome closure to provide extra room for the electron- or ion-beam diode.

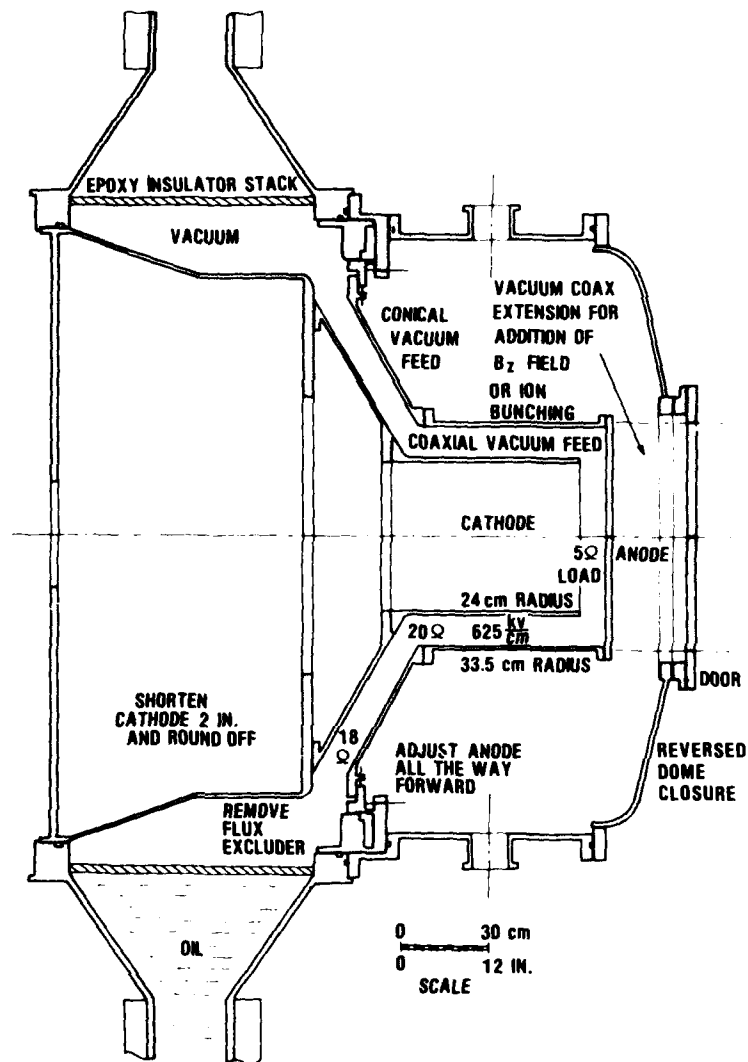

Figure 4. Front end modifications for IDAMP.

These modifications can be accomplished with a minimum of machining. These modifications can be compared directly with the existing AMP front end in figure 5. Especially attractive is that this modification preserves the existing anode centering and alignment apparatus. Additional flexibility can easily be provided with IDAMP by extending the 20- Ω coaxial vacuum-feed section through the 75-cm-diameter door opening in the dome closure. This extension will permit the addition of external magnetic-field (B_z) coils for high-fluence electron beams or the addition of an evacuated drift tube for ion focusing and bunching.

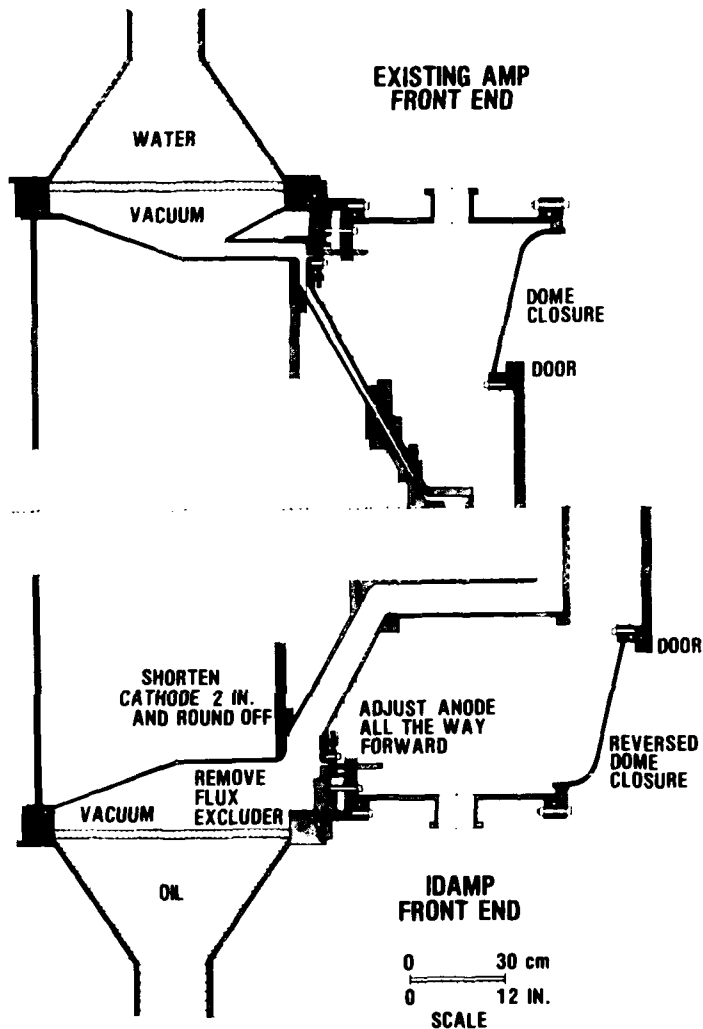

Figure 5. Comparison of IDAMP front end with existing AMP front end.

3. POWER FLOW ANALYSIS

3.1 Circuit

Figure 6 shows a schematic diagram of the IDAMP pulser including the AURORA Marx and Blumleins and the IDAMP modifications to the existing AMP water line. The intermediate cylinder in each of the four Blumleins is connected in parallel with the other three intermediate cylinders, giving a total capacitance to ground of 55 nF. It is

estimated that the interconnection between the intermediate cylinders and their connection to the vertical coaxial transmission line has an inductance of 6.75 μH .

As proposed, IDAMP would function in much the same way as the AMP water line. The intermediate cylinders of the Blumleins act as intermediate storage capacitors. This intermediate store dumps its energy into a 7-nF PFL, which consists of virtually all of AMP up to the position of the epoxy prepulse slab. This slab is replaced with an oil output switch estimated to be 65 nH and consisting of 12 electrodes that discharge the new PFL into the load through the epoxy-vacuum interface. The flux excluders of AMP are removed to shape the front end as shown in figure 4.

For this report, the circuit of figure 6 was analyzed by using the general circuit analysis program NET II. To facilitate an auxiliary analysis using the HDL adaptation of the Naval Research Laboratory transmission-line transient analysis program, some inductors and capacitors were modeled as short transmission lines.

For the analysis, calculations were run in three stages. In the first stage, a computer run was done of the Marx-to-Blumlein energy transfer without any switching in AMP. From this first run, a voltage was chosen for which it appeared there would be an optimal transfer to the new PFL. In the second stage, a run was done for which the main switch fired at that voltage, but for which the output switch remained open. From this second stage run, a firing voltage for the output switch was chosen on which the third stage run was based. This third stage run simulated the entire sequence from the charge of the Blumleins to the discharge to the load. In figure 6, the coaxial Blumlein cylinders represent the parallel combination of the four actual Blumlein networks.

Two cases for using IDAMP were analyzed. The first case corresponded to charging the Marx to 90 kV (a moderate voltage for both positive and negative polarities) and assumed a 5- Ω load, main switch closure at 1820 ns, and output switch closure at 2500 ns. The second case corresponded to charging the Marx to 105 kV and assumed a 3.5- Ω load, main switch closure at 1880 ns, and output switch closure at 2730 ns. These sets of parameters kept the voltage across the oil-epoxy-vacuum interface to a maximum around the 5 MV for which it was designed.

Figure 7 shows the voltage traces from the third stage run of the 90-kV case. Also shown as a function of time is the accumulated electromagnetic energy flowing downstream past various points in the pulser. Similar traces are shown in figure 8, corresponding to the 105-kV case.

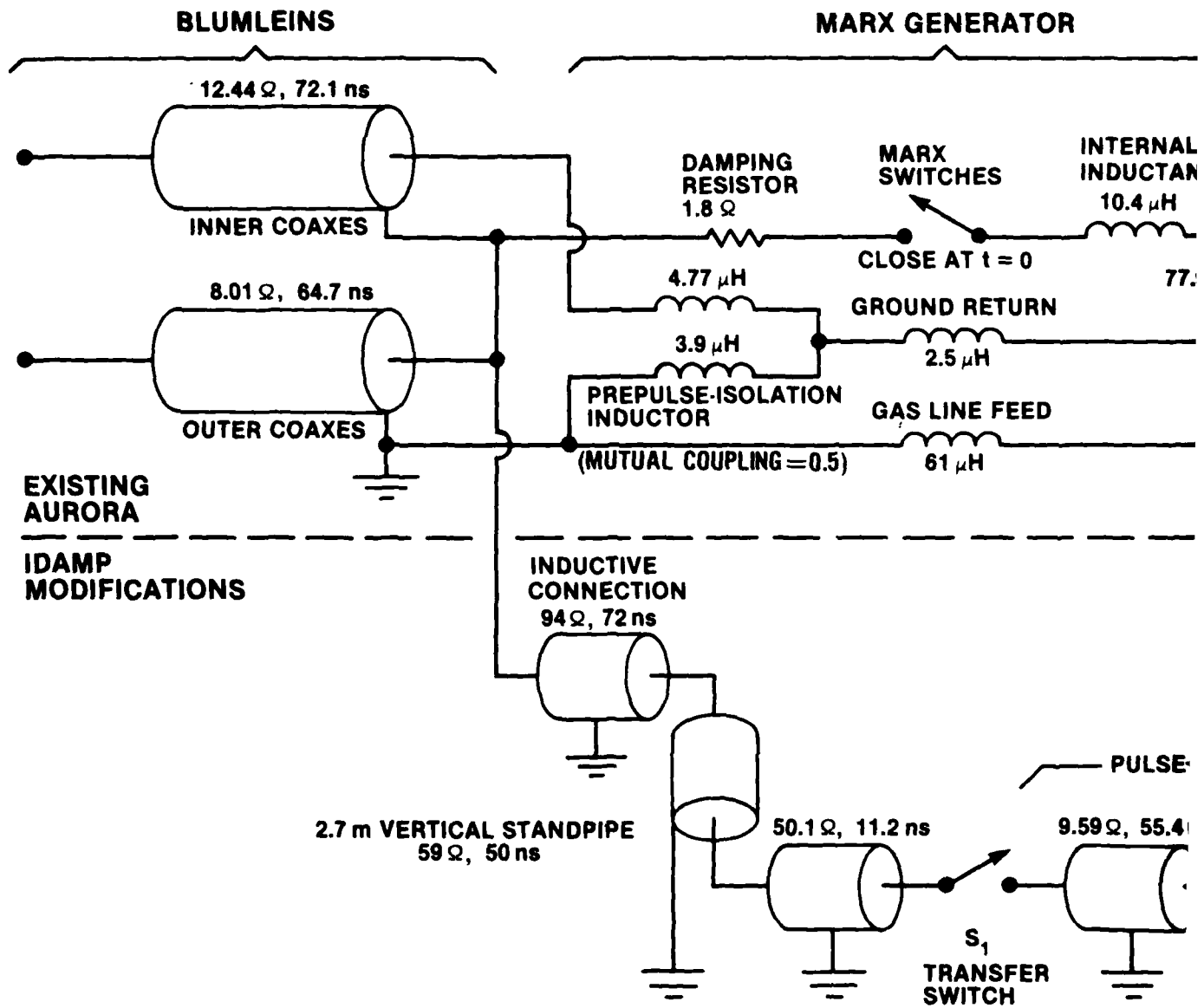
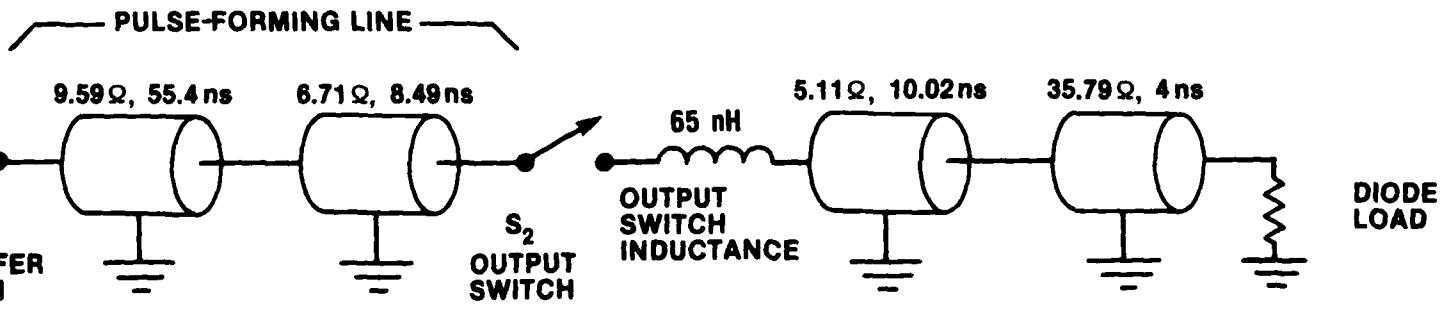
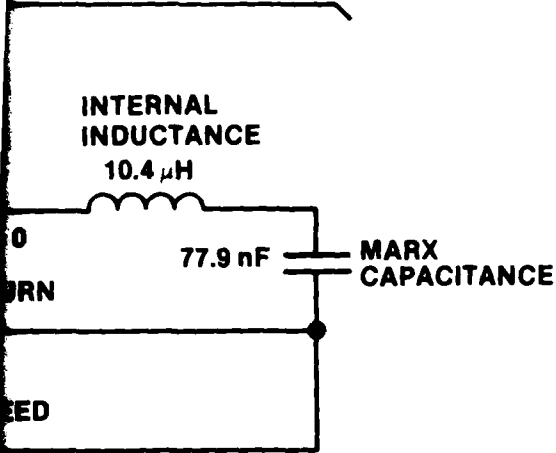

Figure 6. IDAMP circuit schematic diagram.

TOR



ematic diagram used for preliminary analysis.

2

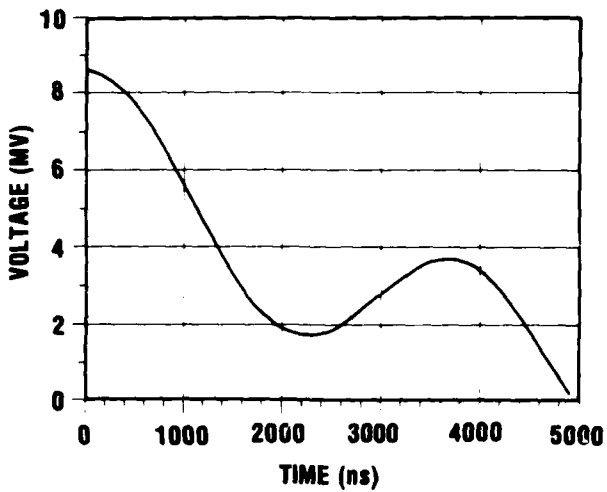

(a) ERECTED MARX GENERATOR

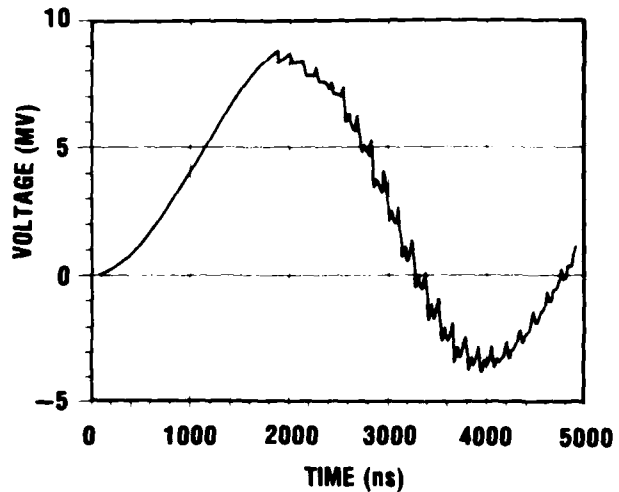

(b) BLUMLEINS (INTERMEDIATE STORE)

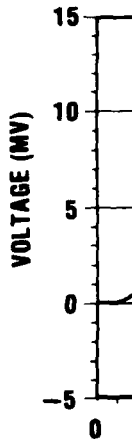

(c) 1

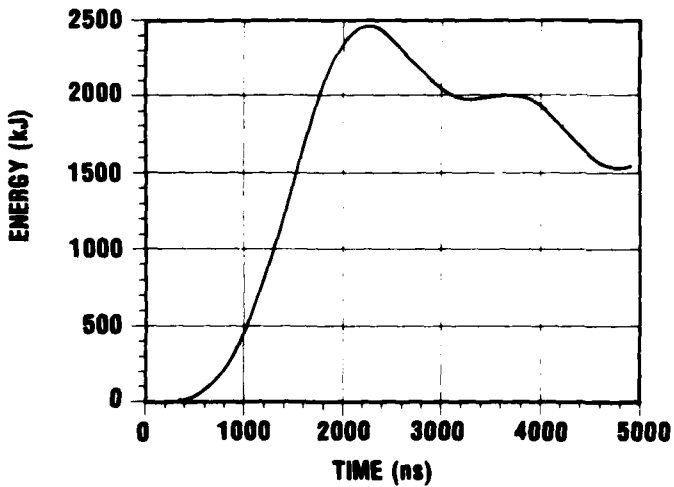

(f) TRANSFERRED FROM MARX

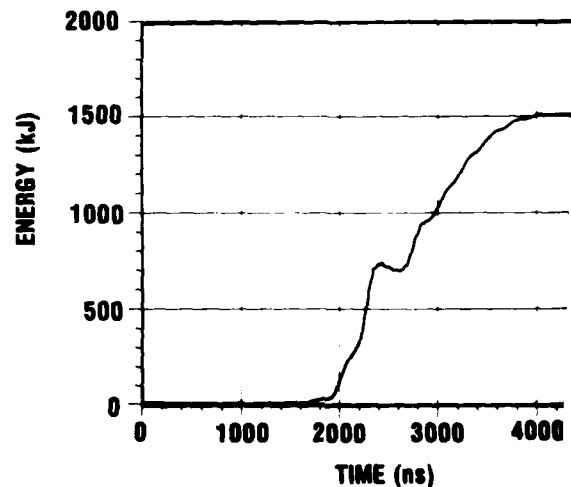

(g) TRANSFERRED THROUGH TRANSFER

Figure 7. Calculated volt.

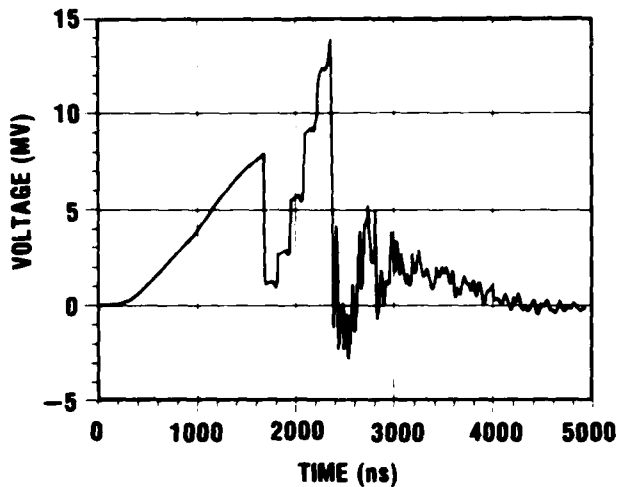

(c) TRANSFER SWITCH, S₁ (MARX SIDE)

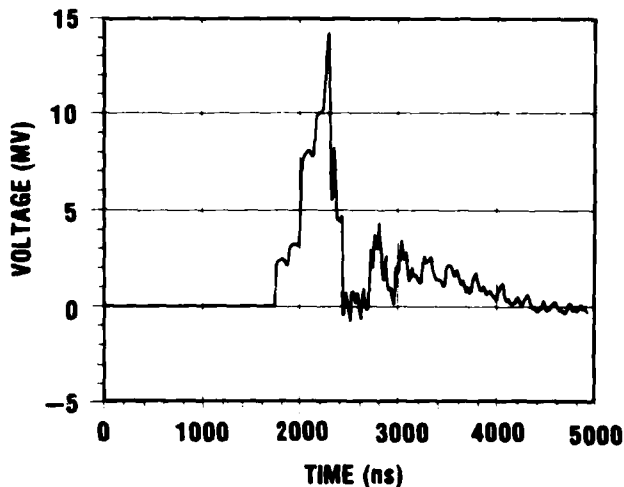

(d) OUTPUT SWITCH, S₂ (MARX SIDE)

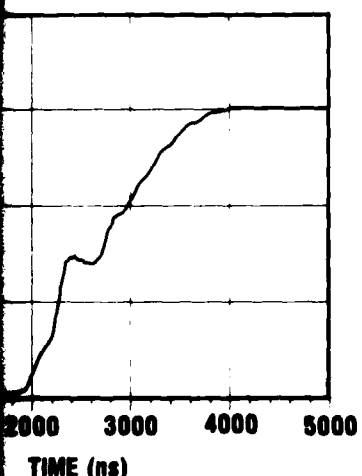

(e) THROUGH TRANSFER SWITCH

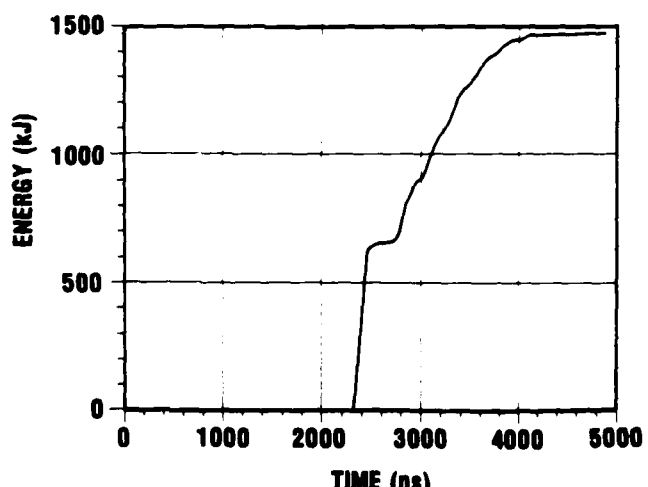

(h) TRANSFERRED TO LOAD

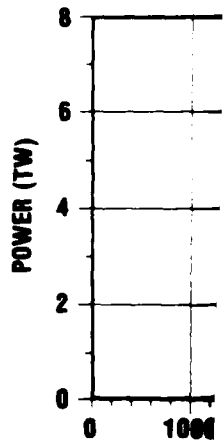

calculated voltage and energy flow at 90-kV Marx charge with 5-Ω load.

12

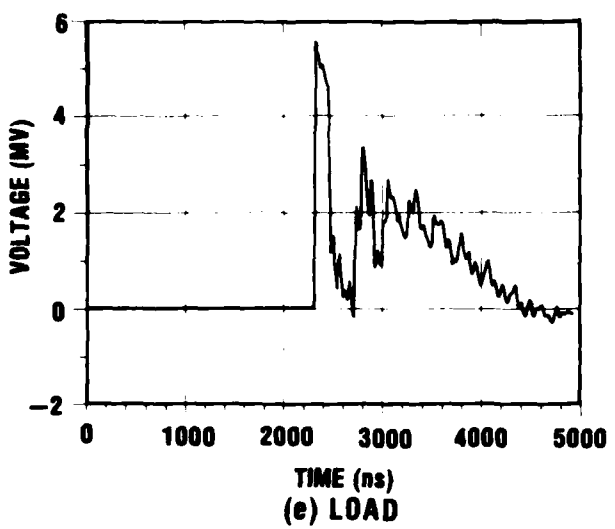

X SIDE)

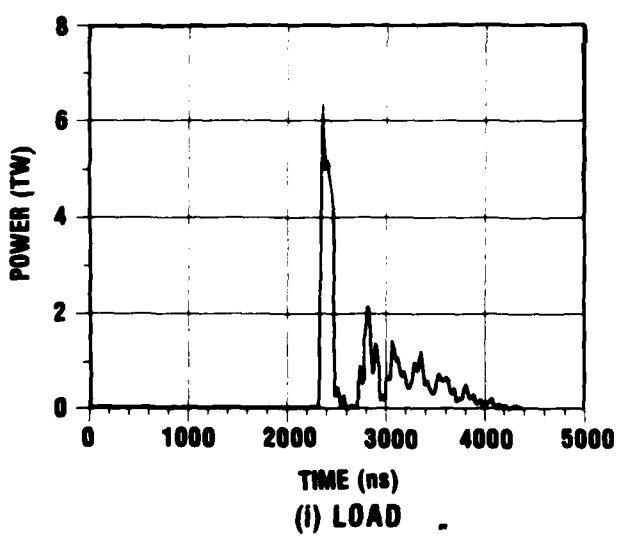

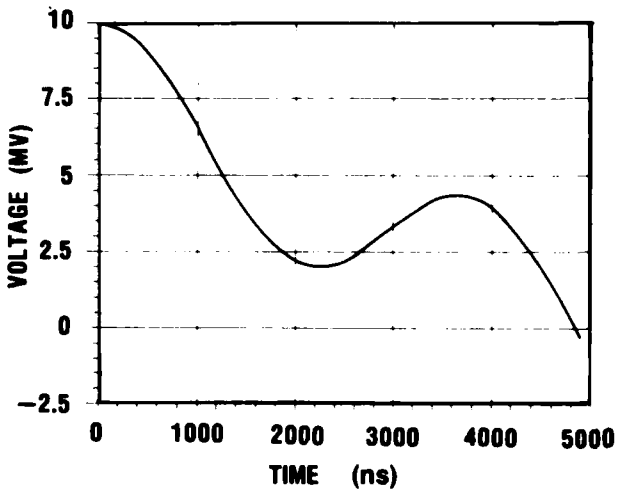

(a) ERECTED MARX GENERATOR

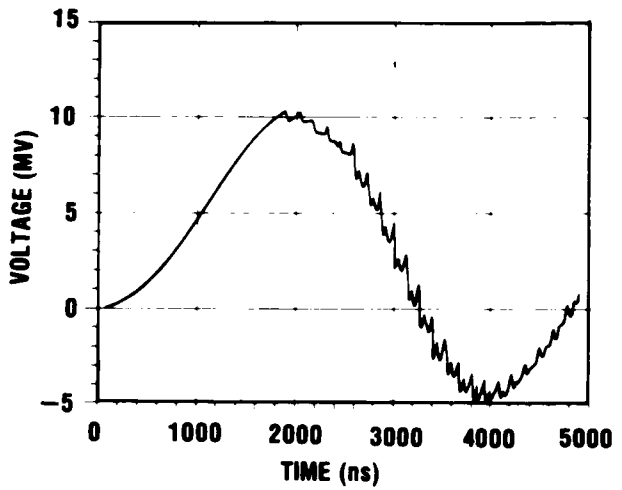

(b) BLUMLEINS (INTERMEDIATE STORE)

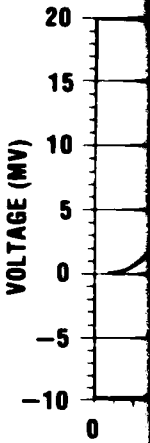

(c) TRANSFER

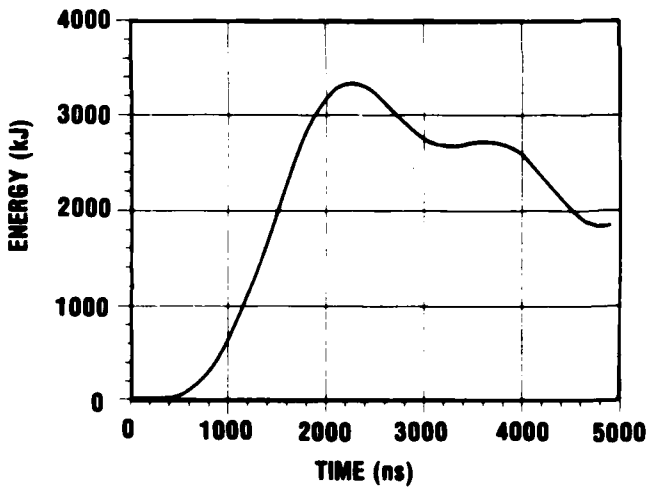

(f) TRANSFERRED FROM MARX

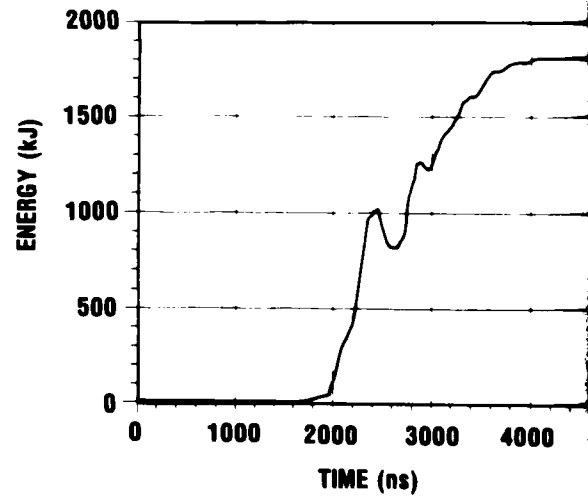

(g) TRANSFERRED THROUGH TRANSFER

Figure 8. Calculated voltage

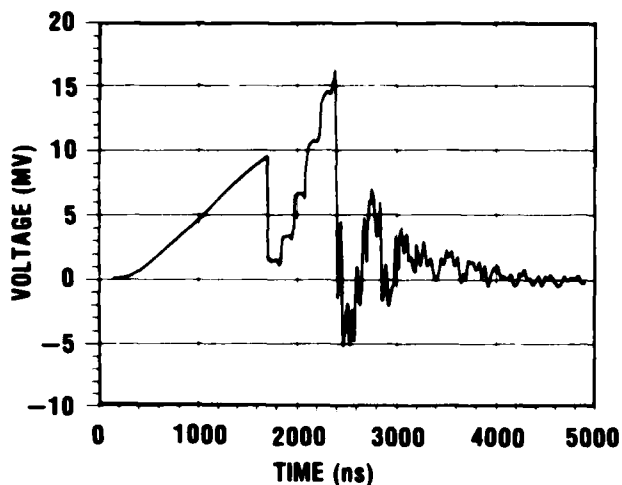

(c) TRANSFER SWITCH, S_1 (MARX SIDE)

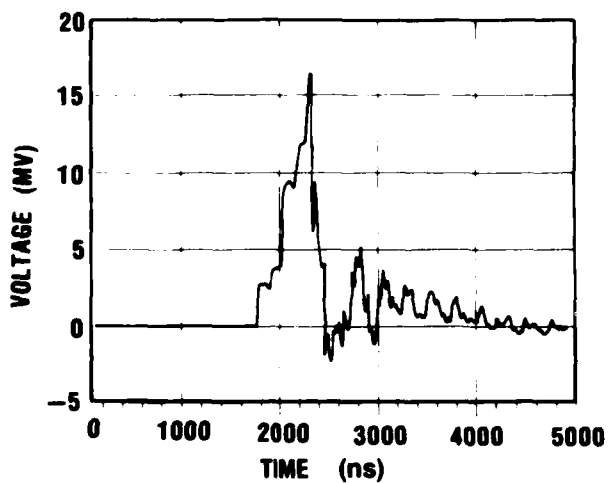

(d) OUTPUT SWITCH, S_2 (MARX SIDE)

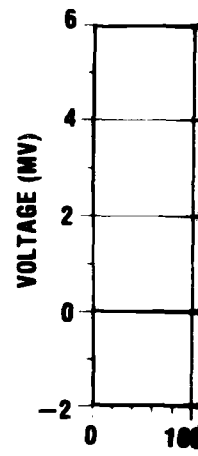

STORE)

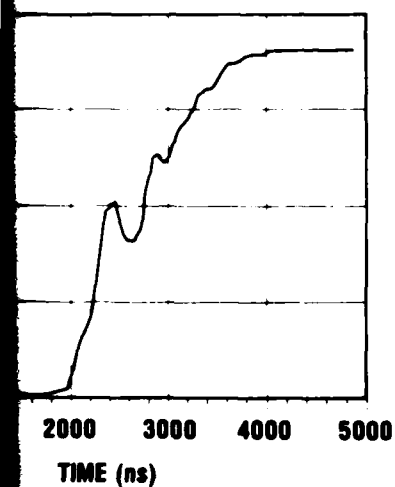

THROUGH TRANSFER SWITCH

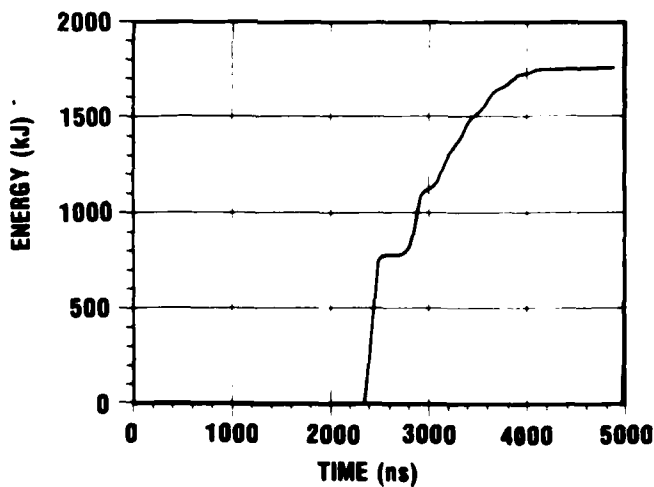

(h) TRANSFERRED TO LOAD

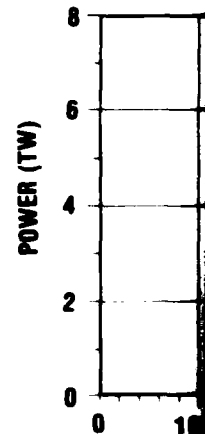

Calculated voltage and energy flow at 105-kV Marx charge with $3.5\text{-}\Omega$ load.

12

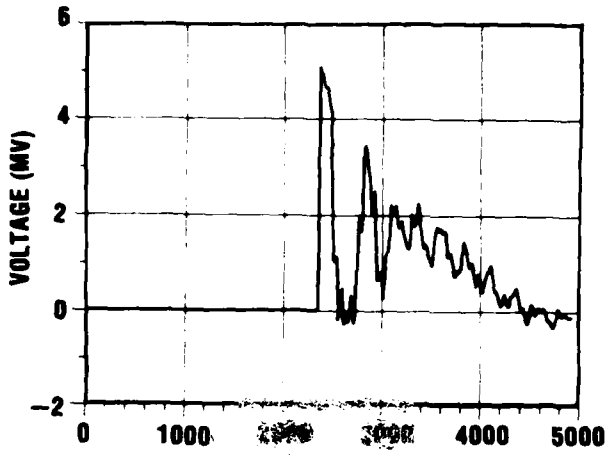
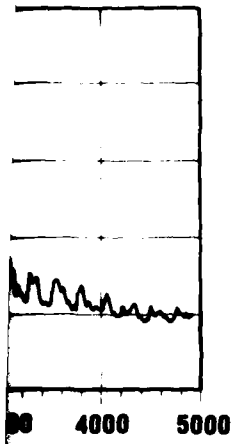

2 (MARX SIDE)

(i) LOAD

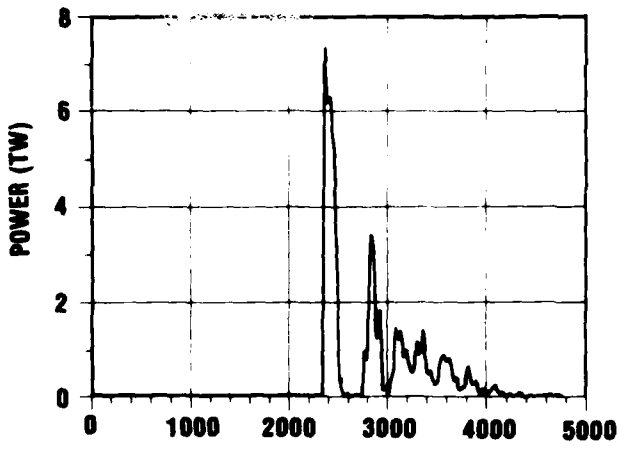

TIME (ns)

(i) LOAD

load.

1 3

3.2 Pulse-Forming Line

To achieve a power output of ≥ 5 TW while holding the diode tube voltage to < 5 MV, it is necessary to reach a voltage level of ≈ 14 MV on the IDAMP PFL before the switch closes. At this voltage, the electric field on the inner line is 32 MV/m (negative polarity) and 25 MV/m (positive polarity) on the outer coaxial cylinder. The intermediate cylinders of the AURORA Blumleins operate reliably when subjected to fields of at least 20 MV/m (negative polarity) and 17.5 MV/m (positive polarity). Allowing for the much shorter effective time to which the IDAMP PFL is subjected (200 versus 700 ns) and the much smaller ($< 1/6$) electrode areas exposed to the high electric field, the tolerable electric fields in IDAMP should be at least a factor of 1.65 over those obtained in AURORA. That is, IDAMP electric fields of 33 MV/m (negative polarity) on the inner coaxial cylinder and 28 MV/m (positive polarity) on the outer coaxial cylinder should be as practical as conventional AURORA operation. These values permit PFL voltages in excess of 14 MV on IDAMP.

3.3 Diode

The following values of the diode parameters could easily be obtained with the IDAMP pulser:

Peak electron energy	5 MeV	3 MeV
Peak current	1 MA	1.2 MA
Load impedance	5 Ω	2.5 Ω
Peak power	5 TW	3.6 TW
FWHM (power pulse)	150 ns	150 ns
Energy to load	750 kJ	540 kJ
Ratio of current to Alfvén current, I/I_A	5.4	10

By using the relativistically correct, one-dimensional space charge limit derived by Jory and Trivelpiece¹ and assuming a uniform current density inside the radius r , the diode gap impedance is to a close approximation

$$\frac{Zr^2}{d^2} = \frac{117\phi}{(\gamma^{1/2} - 0.85)^2}, \text{ for } \phi > 0.5 \text{ MeV},$$

¹H. R. Jory and A. W. Trivelpiece, *J. Appl. Phys.*, 40 (1969), 3924.

where

Z = gap impedance,

r = cathode radius,

d = A-K gap,

ϕ = cathode voltage (megavolts),

$\gamma = e\phi/mc^2 + 1$.

For a 5- Ω load at 5 MV, $r/d = 4.4$. For a 2.5- Ω load at 3 MV, $r/d = 6.7$.

If the anode and cathode plasmas are both closing at 2 cm/ μ s, the impedance will decrease about 40 percent in the 150-ns pulse width, with an A-K gap of 3 cm. So at 2.5 Ω , the cathode must be at least 20 cm in radius; at 5 Ω , at least 13 cm in radius. As seen in figure 4, a 24-cm-radius cathode is available with little modification to the present AMP, allowing a 5.5-cm gap at 5 Ω . The suggested 20- Ω vacuum coaxial feed section should provide magnetic insulation for either 5 or 2.5 Ω . As noted in figure 4, the present door at the rear of the chamber is large enough to permit an extension of the vacuum coaxial feed section.

4. APPLICATIONS

4.1 Ion Diode

The trend in ion diodes at Sandia National Laboratories and the Naval Research Laboratory is toward medium impedances of a few ohms at 1 to 10 MeV. With this proposed IDAMP 5-TW diode, at 5 MeV one could obtain ion beams suitable for transport, bunching, and target response experiments. Depending on the pulse shape obtained, bunching will require 1 to 4 m of drift distance, which is obtainable with the present location of AMP.

4.2 Thermal Structures Response

The use of electron beams to simulate the effect of x-rays on structures requires a beam with an average electron energy of ≈ 3 MeV and a delivered energy of >0.5 MJ (according to the Defense Nuclear Agency). The only pulser in the United States to provide this beam would be IDAMP. A longitudinal magnetic flux density of about 1 T would be needed for this application. The magnetic field would probably be pulsed and would require an energy store of greater than 1/2 MJ. Discussions with Maxwell Laboratories, Inc., indicate that this magnetic field is readily obtainable.

4.3 Radiation Effects

The current in IDAMP will be approximately equal to the sum of all four of the diodes on the conventional AURORA. The present AURORA has tube voltages of about 8 MV at a 90-kV Marx charge and 10 MV at a 110-kV Marx charge. The IDAMP bremsstrahlung radiation field at distances greater than the source diameter will then be about 25 percent of the present AURORA field at 90-kV operation and 15 percent of the AURORA field at 110-kV operation. (A modified insulator stack to hold off 5 MV would greatly enhance the bremsstrahlung production.) The rise time will be much faster than that of the present AURORA. The tube could be run in a pinched beam mode to produce very high dose, dose rate, and derivative of dose rate (D , \dot{D} , \ddot{D}) over a smaller area. This would be a more practical operation than that of the present AURORA because of the comparative ease of cleaning the tube insulators after a high-current density shot.

The diode could be used in conjunction with a thin foil converter to provide an intense source of low-energy photons. This soft x-ray source could be enhanced by lowering the gap impedance below 2Ω , although doing so would require a somewhat more extensive vacuum-feed modification than is described here.

There would be an added advantage to IDAMP as a radiation effects facility in that large objects such as tanks could be brought through the 22-ft (6.6-m) rollup door. High-quality cables exist from the proposed IDAMP front end running to the data room.

4.4 Source-Region Electromagnetic Pulse

The short rise time predicted for this pulser will make the bremsstrahlung output suitable for SREMP experiments. In addition, the withdrawing of the energy diverter could provide a long fall time to the pulse.

The IDAMP pulser in the electron-beam mode would make a useful addition to the present facility for injecting electrons into the test area for fast-rising air ionization for SREMP applications. The present AURORA would continue to be used for large-value air ionization, while IDAMP could address the problem of injecting electron beams into an antenna with no built-in return current paths as exist in the present test cell. This addition would allow research into the problem being faced in a proposed SREMP facility prior to its construction.

Once again, the ability to bring large objects into the test area and the existence of cables are major advantages.

4.5 Microwaves

Present techniques of generating intense bursts of microwaves are aimed toward repetitively pulsed or continuous wave operation and do not use very high peak power pulses. However, future research in free electron lasers and on microwaves from reflex triodes and diodes at HDL may benefit from the long-pulse, high-voltage source where the current can be varied by the use of dummy loads. In particular, if the directed energy weapon use of microwaves continues to be of interest, a high-output energy pulser will be needed for feasibility studies. According to Sullivan, the flat-topped voltage pulse is desirable.²

5. AURORA FACILITY MODIFICATIONS FOR IDAMP

The necessary electricity and water provided for AMP can be used for IDAMP, so no further expense need be incurred. High-quality signal and machine diagnostic cables are in place from AMP to the AURORA data and control rooms, and they can be used for IDAMP.

The only significant IDAMP modification will be for radiation shielding. Since AMP was a driver for a low-impedance wire load, the bremsstrahlung was contained by a steel door. The proposed 5-MeV broad source application will require more radiation shielding. Concrete blocks can be used, and possibly the area ahead of AMP can be cleared for each shot. Direct and sky-shine radiation were calculated by AURORA personnel for AMP and were included in the environmental impact statement. The necessary computer codes are available, and the shielding calculations can be upgraded to the 5-MeV operation.

6. CONCLUSIONS AND RECOMMENDATIONS

The preliminary analysis presented here indicates that, for a modest expenditure and by using the existing AMP hardware, IDAMP could be built as a 5-TW, 5-MV pulse power source.

This proposed off-line medium-impedance IDAMP pulser could be operated with a minimum disruption of normal AURORA operations, could be operated in positive polarity, and with only one output switch would be capable of high-resolution synchronization with user experiments.

²D. J. Sullivan, *Bull. Am. Phys. Soc.*, 25 (October 1980), 948.

Applications for this new pulser are extensive. Examples of potential uses for this proposed machine are ion diode (positive polarity), thermal structures response, SREMP bremsstrahlung, and high-intensity low-energy x-rays. All of these are either not possible or only marginally possible with AURORA at present.

It is recommended that a more detailed study be conducted to determine the critical elements and possible problem areas associated with the implementation of this very promising research and testing tool.

DISTRIBUTION

ADMINISTRATOR
DEFENSE TECHNICAL INFORMATION CENTER
ATTN DTIC-DDA (12 COPIES)
CAMERON STATION, BUILDING 5
ALEXANDRIA, VA 22314

COMMANDER
US ARMY RSCH & STD GP (EUR)
ATTN CHIEF, PHYSICS & MATH BRANCH
FPO NEW YORK 09510

COMMANDER
US ARMY ARMAMENT MATERIEL
READINESS COMMAND
ATTN DR SAR-LEP-L, TECHNICAL LIBRARY
ROCK ISLAND, IL 61299

COMMANDER
US ARMY MISSILE & MUNITIONS
CENTER & SCHOOL
ATTN ATSK-CTD-F
REDSTONE ARSENAL, AL 35809

DIRECTOR
US ARMY MATERIEL SYSTEMS ANALYSIS
ACTIVITY
ATTN DRXSY-MP
ABERDEEN PROVING GROUND, MD 21005

DIRECTOR
US ARMY BALLISTIC RESEARCH LABORATORY
ATTN DR DAR-TSB-S (STINFO)
ABERDEEN PROVING GROUND, MD 21005

US ARMY ELECTRONICS TECHNOLOGY
& DEVICES LABORATORY
ATTN DELET-DD
FT MONMOUTH, NJ 07703

HQ, USAF/SAMI
WASHINGTON, DC 20330

TELEDYNE BROWN ENGINEERING
CUMMINGS RESEARCH PARK
ATTN DR. MELVIN L. PRICE, MS-44
HUNTSVILLE, AL 35807

ASSISTANT TO THE SECRETARY OF DEFENSE
(ATOMIC ENERGY)
ATTN EXECUTIVE ASSISTANT
WASHINGTON, DC 20301

DIRECTOR
DEFENSE INTELLIGENCE AGENCY
ATTN DT-1B, R. RUBENSTEIN
WASHINGTON, DC 20301

DIRECTOR
DEFENSE NUCLEAR AGENCY
ATTN TITL
ATTN DLST
ATTN RAEV
ATTN STNA
WASHINGTON, DC 20305

COMMANDER
FIELD COMMAND
DEFENSE NUCLEAR AGENCY
ATTN PEPR
KIRTLAND AFB, NM 87115

CHIEF
FIELD COMMAND
DEFENSE NUCLEAR AGENCY
LIVERMORE BRANCH
ATTN POPPL
P.O. BOX 808,
LIVERMORE, CA 94550

DIRECTOR
JOINT STRATEGY PLANNING STAFF
OFFUTT AFB
ATTN JLA
ATTN JSAS
OMAHA, NE 68113

UNDER SECY OF DEF FOR RSCH & ENGRG
DEPARTMENT OF DEFENSE
ATTN STRATEGIC & SPACE SYST
WASHINGTON, DC

DEP CH OF STAFF FOR RSCH DEV & ACQ
DEPARTMENT OF THE ARMY
ATTN DAMA-CSS-N
WASHINGTON, DC 20310

COMMANDER
US ARMY MISSILE COMMAND
ATTN DRCPM-PE-EA
ATTN RSIC
REDSTONE ARSENAL, AL 35809

COMMANDER
US ARMY NUCLEAR & CHEMICAL AGENCY
ATTN LIBRARY
7500 BACKLICK ROAD
BUILDING 2073
SPRINGFIELD, VA 22150

COMMANDER
US ARMY TEST AND EVALUATION COMMAND
ATTN DRSTE-EL
ABERDEEN PROVING GROUND, MD 21005

DISTRIBUTION (cont'd)

COMMANDER
NAVAL INTELLIGENCE SUPPORT CTR
4301 SUTLAND ROAD, BLDG 5
ATTN NISC-45
WASHINGTON, DC 20390

DIRECTOR
NAVAL RESEARCH LABORATORY
ATTN CODE 4701, J. BROWN
ATTN CODE 7550, J. DAVIS
ATTN CODE 6770, G. COOPERSTEIN
WASHINGTON, DC 20375

COMMANDER
NAVAL SURFACE WEAPONS CENTER
ATTN CODE R40, RADIATION DIV
ATTN CODE F31
WHITE OAK, MD 20910

COMMANDER
NAVAL WEAPONS CENTER
ATTN CODE 233, TECH LIB
CHINA LAKE, CA 93555

OFFICE OF THE CHIEF OF NAVAL OPERATIONS
ATTN OP 604E14, R. BLAISE
WASHINGTON, DC 20350

AFWL/DYC
ATTN SUL
ATTN CA
ATTN DYC
ATTN NT
ATTN DYP
KIRTLAND AFB, NM 87117

BALLISTIC MISSILE OFFICE/MN
AIR FORCE SYSTEMS COMMAND
(MINUTEMAN)
ATTN MNNH
ATTN MNRTE
NORTON AFB, CA 92409

DEPUTY CHIEF OF STAFF
RESEARCH & DEVELOPMENT
DEPARTMENT OF THE AIR FORCE
ATTN AFRDQSM
WASHINGTON, DC 20330

HEADQUARTERS SPACE DIVISION/IN
AIR FORCE SYSTEMS COMMAND
PO BOX 92960
WORLDWAY POSTAL CENTER
(INTELLIGENCE)
ATTN IND, D. MUSKIN
LOS ANGELES, CA 90009

HEADQUARTERS SPACE DIVISION/SK
AIR FORCE SYSTEMS COMMAND
PO BOX 92960
WORLDWAY POSTAL CENTER
(SPACE COMM SYSTEMS)
ATTN SKF, P. STADLER
LOS ANGELES, CA 90009

DEPARTMENT OF ENERGY
ATTN OFC OF INERT FUSION, T. GODLOVE
ATTN OFC OF INERT FUSION, C. HILLAND
ATTN OFC OF INERT FUSION, S. KAHALAS
WASHINGTON, DC 20545

ADVANCED RESEARCH & APPLICATIONS CORP
1223 E. ARQUES AVENUE
ATTN R. ARMISTEAD
SUNNYVALE, CA 94086

AVCO RESEARCH & SYSTEMS GROUP
201 LOWELL STREET
ATTN LIBRARY A830
WILMINGTON, MA 01887

BDM CORP.
7915 JONES BRANCH DRIVE
ATTN CORPORATE LIBRARY
MCLEAN, VA 22102

BOEING CO.
PO BOX 3707
ATTN AEROSPACE LIBRARY
SEATTLE, WA 98124

DIKEWOOD CORPORATION
1613 UNIVERSITY BLVD, NE
ATTN L. DAVIS
ALBUQUERQUE, NM 87102

EG&G WASHINGTON ANALYTICAL
SERVICES CENTER, INC.
PO BOX 10218
ATTN LIBRARY
ALBUQUERQUE, NM 87114

GENERAL ELECTRIC CO.
SPACE DIVISION
VALLEY FORGE SPACE CENTER
PO BOX 8555
ATTN J. PEDEN
PHILADELPHIA, PA 19101

INSTITUTE FOR DEFENSE ANALYSES
400 ARMY-NAVY DRIVE
ATTN CLASSIFIED LIBRARY
ARLINGTON, VA 22202

DISTRIBUTION (Cont'd)

IRT CORP.
PO BOX 81087
ATTN R. MERTZ
SAN DIEGO, CA 92138

JAYCOR
11011 TORREYANA ROAD
PO BOX 85154
ATTN E. WENAAS
SAN DIEGO, CA 92138

JAYCOR
205 S. WHITING STREET, SUITE 500
ATTN R. SULLIVAN
ALEXANDRIA, VA 22304

KAMAN SCIENCES CORP.
PO BOX 7463
ATTN A. BRIDGES
ATTN J. HOFFMAN
ATTN D. BRYCE
ATTN W. WARE
COLORADO SPRINGS, CO 80933

KAMAN TEMPO
2560 HUNTINGTON AVE - SUITE 506
ATTN DASIAC
ALEXANDRIA, VA 22303

LAWRENCE LIVERMORE NATIONAL LABORATORY
PO BOX 808
ATTN DOC CON FOR L-47, L. WOUTERS
ATTN DOC CON FOR TECHNICAL INFORMATION
DEPT LIBRARY
ATTN DOC CON FOR L-153
ATTN DOC CON FOR L-153, D. MEEKER
ATTN DOC CON FOR L-545, J. NUCKOLLS
ATTN DOC CON FOR L-401, W. PICKLES
LIVERMORE, CA 94550

LOCKHEED MISSILES & SPACE CO., INC.
3251 HANOVER STREET
ATTN L. CHASE
PALO ALTO, CA 94304

LOCKHEED MISSILES & SPACE CO., INC.
PO BOX 504
ATTN S. TAIMUTY
SUNNYVALE, CA 94086

LOS ALAMOS NATIONAL SCIENTIFIC LABORATORY
MAIL STATION 5000
PO BOX 1663
ATTN DOC CON FOR MS222, J. BROWNELL
LOS ALAMOS, NM 87545

MAXWELL LABS, INC.
9244 BALBOA AVENUE
ATTN A. MILLER
ATTN P. KORN
ATTN A. KOLB
SAN DIEGO, CA 92123

MCDONNELL DOUGLAS CORP.
5301 BOLSA AVENUE
ATTN S. SCHNEIDER
HUNTINGTON BEACH, CA 92647

MISSION RESEARCH CORP.
PO DRAWER 719
ATTN C. LONGMIRE
ATTN W. HART
SANTA BARBARA, CA 93102

MISSION RESEARCH CORP.
EM SYSTEM APPLICATIONS DIVISION
1400 SAN MATEO BLVD, SE, SUITE A
ATTN B. GODFREY
ALBUQUERQUE, NM 87108

MISSION RESEARCH CORP.--SAN DIEGO
PO BOX 1209
(VICTOR A. J. VAN LINT)
ATTN V. VAN LINT
LA JOLLA, CA 92038

NORTHROP CORP.
NORTHROP RESEARCH & TECHNOLOGY CTR
1 RESEARCH PARK
ATTN LIBRARY
PALOS VERDES PENINSULA, CA 90274

PHYSICS INTERNATIONAL CO.
2700 MERCED STREET
ATTN S. PUTNAM
ATTN P. SPENCE
ATTN B. BERNSTEIN
ATTN C. STALLINGS
ATTN K. CHILDERS
ATTN A. TOEPFER
SAN LEANDRO, CA 94577

R & D ASSOCIATES
PO BOX 9695
ATTN W. GRAHAM, JR.
ATTN L. SCHLESSINGER
ATTN C. MACDONALD
MARINA DEL REY, CA 90291

DISTRIBUTION (Cont'd)

SANDIA NATIONAL LABORATORIES
PO BOX 5800
ATTN MAIL SERVICES SECT FOR 3141
ATTN MAIL SERVICES SECT FOR G. YONAS
ATTN MAIL SERVICES SECT FOR G. KUSWA,
ORG 5240
ATTN MAIL SERVICES SECT FOR M. CLAUSER,
ORG 5241
ALBUQUERQUE, NM 87185

SCIENCE APPLICATIONS, INC.
PO BOX 2351
ATTN J. BEYSTER
LA JOLLA, CA 92038

SPIRE CORP.
PO BOX D
ATTN R. LITTLE
BEDFORD, MA 01730

SRI INTERNATIONAL
333 RAVENSWOOD AVENUE
ATTN S. DAIRIKI
MENLO PARK, CA 94025

SYSTEMS, SCIENCE & SOFTWARE, INC.
PO BOX 1620
ATTN A. WILSON
LA JOLLA, CA 92038

TEXAS TECH UNIVERSITY
PO BOX 5404, NORTH COLLEGE STATION
ATTN T. SIMPSON
LUBBOCK, TX 79417

TRW DEFENSE & SPACE SYS GROUP
ONE SPACE PARK
ATTN TECHNICAL INFORMATION CENTER
REDONDO BEACH, CA 90278

US ARMY ELECTRONICS RESEARCH
& DEVELOPMENT COMMAND
ATTN TECHNICAL DIRECTOR, DRDEL-CT

HARRY DIAMOND LABORATORIES
ATTN CO/TD/TSO/DIVISION DIRECTORS
ATTN RECORD COPY, 81200
ATTN HDL LIBRARY, 81100 (2 COPIES)
ATTN HDL LIBRARY, 81100 (WOODBRIDGE)
ATTN TECHNICAL REPORTS BRANCH, 81300
ATTN CHAIRMAN, EDITORIAL COMMITTEE
ATTN LEGAL OFFICE, 97000
ATTN MORRISON, R., 13500 (GIDEP)
ATTN CHIEF, 21000
ATTN CHIEF, 21100
ATTN CHIEF, 21200
ATTN CHIEF, 21300
ATTN CHIEF, 21400
ATTN CHIEF, 21500
ATTN CHIEF, 22000
ATTN CHIEF, 22100
ATTN CHIEF, 22300
ATTN CHIEF, 22800
ATTN CHIEF, 22900
ATTN CHIEF, 20240
ATTN EISEN, H., 22800
ATTN MCGARRITY, J., 22300
ATTN KERRIS, K. G., 22900 (100 COPIES)

ATE
LMED
-8