

AD-A111 784

BOEING MILITARY AIRPLANE CO SEATTLE WA
CURRENT STATUS OF INLET FLOW PREDICTION METHODS, (U)
MAY 81 © C PAYNTER

F/G 21/5

UNCLASSIFIED

NL

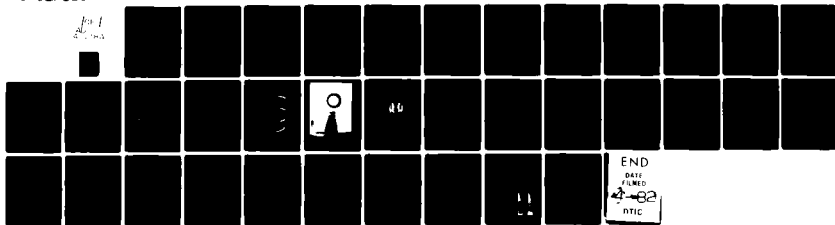

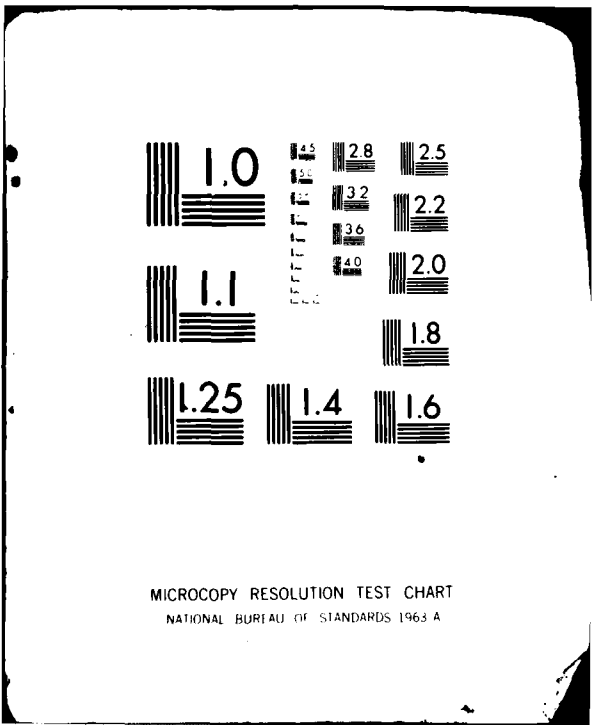

MICROCOPY RESOLUTION TEST CHART
NATIONAL BUREAU OF STANDARDS 1963 A

22

CURRENT STATUS OF INLET FLOW PREDICTION METHODS

Gerald C. Paynter
Boeing Military Airplane Company
Seattle, Washington 98124

AD A111784

ABSTRACT

18 June 81

The increasing availability of large computers, advances in numerical fluid mechanics, and the rapidly escalating cost of wind tunnel testing are responsible for a trend toward the use of parametric analysis rather than parametric testing to support the design of inlet systems. With an emphasis on the transonic and supersonic speed regimes, current approaches to inlet flow analysis are discussed in the context of the inlet design process. Results from typical procedures now under development for supersonic inlet flows are presented along with a discussion of the advantages and disadvantages of each for design. The requirements for experimental validation of a procedure and analysis problem areas are reviewed. Recent developments which may lead to an improved inlet flow analysis capability are discussed.

INTRODUCTION

Inlet performance may be defined in terms of inlet recovery, distortion, drag, weight, maneuverability, controllability, stability, starting characteristics, etc. The function of the inlet is to prepare the flow for the engine by capturing and compressing a desired weight flow rate to a chosen state while minimizing losses associated with the compression process and the inlet installation. Inlet performance is usually closely related to the boundary layer development through and around the inlet. A boundary layer developing through the adverse pressure gradients associated with an inlet will thicken more rapidly and have a velocity profile distribution which is less "full" than a boundary layer developing through a constant pressure region. For high adverse pressure gradients, boundary layer separation may occur with high loss of inlet total pressure and high distortion.

In a typical design problem, the losses associated with the compression process are minimized by limiting the thickening and distortion of the boundary layer as the flow develops through the inlet. This is done by contouring the inlet surfaces to control the local gradients in static pressure and by the use of boundary layer control. Constraints on the design are typically the weight, length, location, and drag of the installation. The radar cross-section of an inlet installation is also a constraint for certain military aircraft.

The traditional approach to inlet design is illustrated in Figure 1. In this approach, the geometry of a design concept is varied parametrically and tested at model scale. Configurations are selected on the basis of the model scale test results for full scale validation and optimization. Problems with this approach are the rising cost of wind tunnel testing, uncertain scaling of

FILE COPY

This document has been approved for release and sale; its distribution is unlimited.

II-1

82 08 09



MAR 8 1982

OPTIC ELECTE

A

test results, and the constraints imposed on new designs by the existing test data base. Advanced aircraft, for example, those shown in Figure 2, require inlet systems of a type not in the present data base. Test based design of new inlet systems implies high development cost, high design risk or both.

An alternative to test based design is to replace parametric model scale testing with parametric analysis. This "analysis based" approach is also illustrated in Figure 1. The increasing availability of large computers and advances in numerical fluid mechanics have made possible the use of analysis based design. Major advantages of this approach are lower development cost, a better understanding of the inlet flow processes, and the removal of the existing test data base as a design constraint.

In practice, a design study is usually a composite of both the test and analysis based approaches. The available analysis is used to reduce the required test matrix to the smallest possible number of configurations. Testing is used to evaluate configurations in flow regimes outside the range of the available analyses. As computer size and speed increase and analyses become more powerful, less and less testing is required to achieve a successful design. This trend is illustrated in Figure 3 for the design of conventional subsonic inlets for commercial aircraft.

The goals of inlet flow analyses for design include:

- o analysis of all important flow phenomena
- o programs which are easy to use and understand
- o low computer cost per case
- o easy modification of inlet geometry and flow boundary conditions
- o easy identification of cause and effect relationships

In the sections which follow, the historical development of numerical fluid mechanics and the current status of inlet flow analysis are reviewed. Analysis problem areas are discussed and current approaches toward extending the present capability are described. Promising developments which may lead to significant improvements in capability are briefly discussed.

HISTORICAL DEVELOPMENT

Inlet design prior to 1970 was based on one-dimensional analysis and parametric model scale testing. Key events which led to the use of more powerful flow analyses in the design process were:

- o 1968 Stanford Conference on Computation of Turbulent Boundary Layers
- o The availability of powerful digital computers
- o The American SST program.

The 1968 Stanford Conference produced a set of checked-out standard test cases for a wide range of 2-D or axisymmetric turbulent boundary layer flows. This quickly led to accurate and widely available boundary layer methods. As noted above, accurate prediction of the boundary layer development through an inlet is essential for inlet performance prediction.

The American SST effort started about 1960 and ended in 1971 with the decision by the U.S. Congress to discontinue the project. This effort was

significant because of the major involvement by both Government and Industry to develop SST technology. Commercially viable aircraft required inlets with very high performance. The aerospace industry, faced with this difficult design task, successfully applied the available flow analysis capability including the boundary layer methods which resulted from the 1968 Stanford Conference to the design of the SST inlets. This was the first application of a primarily analysis based design philosophy to the development of a complex inlet system. The striking success of this approach for the development of the SST inlet system was widely recognized.⁽¹⁾

With the cancellation of the SST program, the technology and the design philosophy were infused into other projects through the transfer of people from the program. As illustrated in Figure 3, this has led to major revisions in inlet design practice in the last decade.

The growth in the use of Computational Fluid Dynamics, CFD, for inlet design over the last decade or so paralleled development of CFD technology. This development is illustrated in Figure 4. CFD technology for design has only existed since the early 1960's. Progress, in terms of the number and range of flows predicted, has been slow but steady over the last two decades.

CURRENT STATUS

In the context of the design process, we can at present predict many 2-D or axisymmetric inlet flows and some 3-D inlet flows with sufficient accuracy for many engineering purposes. It is worth noting that the lead time for analysis development is very long. Most methods developed over the last decade are still in use and still under development. Experience has shown that the impact of a new analysis on the design process is to reduce the amount of wind tunnel testing required. New analyses usually do not displace previously useful analyses, which is a point usually not well understood by the research community. The designer will invariably use the simplest and least costly analysis applicable for a given flow. The availability of a powerful but expensive and difficult-to-implement Navier-Stokes procedure, for example, does not negate the usefulness of simpler procedures for design.

The current inlet flow analysis capability is illustrated below through several example flow predictions. These example flows include a subsonic V/STOL inlet at high angle-of-attack, a subsonic diffuser with a rectangular-to-round geometry transition and supersonic axisymmetric inlets operating at low speed, at transonic speed, and at cruise speed.

Example - Subsonic V/STOL Inlet - An asymmetric V/STOL inlet shown in Figure 5 was tested through a range of free stream Mach numbers, angles-of-attack and compressor face Mach numbers.⁽²⁾ In the example flow selected, $M_\infty = .19$, the angle-of-attack was 60° and the compressor face Mach number was .39. This example illustrates that inviscid flow properties characteristic of a 3-D inlet geometry operating at high angle of attack with local regions of transonic flow can be accurately predicted. The 3-D full potential flow analysis of Forester⁽³⁾ was used to compute the surface static pressure distribution through the inlet for the selected test case. This analysis features a body fitted mesh system, solution by SLOR and solution acceleration by Lyusternik extrapolation.



<input checked="" type="checkbox"/>	DTIC
<input type="checkbox"/>	COPY
<input type="checkbox"/>	INSPECTED
	Availability Codes
	Avail and/or
	Special
	A

The computational mesh, Figure 6, was generated using a cubic connecting function mesh generator by Kowalski.⁽⁴⁾ A number of grid densities and domain dimensions were investigated to ensure that the computed results were independent of the mesh and the solution domain. Note that the body fitted mesh system allows high mesh density to be focused in regions where high solution accuracy is required. Since the computational cost is a function of the total number of computational cells used, the ability to use a dense mesh in regions of interest and a sparse mesh where desired, results in a very efficient computational procedure. Computed results for the local surface Mach number in axial planes at three circumferential locations are shown in Figure 7. The results shown required about 30 min. CPU time on a Cyber 175 computer.

Example - Subsonic Diffuser with a Geometry Transition - Subsonic diffusers with geometry transitions were tested by MacMiller⁽⁵⁾ to simulate the subsonic diffusers of supersonic aircraft with rectangular external compression inlets. In the selected example flow, the free stream Mach number at the diffuser entrance was .605 and the boundary layer thickness on all four surfaces of the rectangular diffuser entrance was .5 inches. This example illustrates that a diffuser flow with a geometry transition can be at least qualitatively predicted. A detailed evaluation of this (or any) procedure for this type of flow is not possible because suitable data is not available.

The 3-D parabolized Navier-Stokes procedure of Roberts and Forester⁽⁶⁾ was used to compute this example flow. The analysis features a body fitted mesh system and simulation of turbulent stresses with a $k-\epsilon$ turbulent model. The solution is "marched" down the duct using an iterative ADI procedure. The computational mesh for the example problem was generated with a Thompson et al⁽⁷⁾ mesh generator.

The duct geometry and computed results for the diffuser flow are shown in Figure 8. Again, mesh refinement was done to ensure the computed results were independent of the mesh. Agreement between predicted and measured static pressure distributions on the duct surface along the plane of symmetry is very good. Separation was observed experimentally about two thirds of the way along the duct and this was accurately predicted. Good agreement was obtained between computed and measured boundary layer pitot profiles along the plane of symmetry. This calculation required about 20 minutes CPU time on a Cyber 175 computer.

Example - Supersonic Inlet at Low Speed - An axisymmetric mixed compression inlet, Figure 9, designed for a cruise Mach number of 2.65, will be tested at low speed in early 1982 as part of the NASA Supersonic Cruise Research program.⁽⁸⁾ This low speed test program, to be conducted at the NASA Lewis 9x15 low speed wind tunnel, will be used to provide data on the noise, performance and aerodynamic characteristics of the inlet under low speed operating conditions. The inlet features a translating centerbody, traveling bleed system and take-off doors. In preparation for the low speed test, the inlet flow was analyzed at a number of free stream Mach numbers, inlet flow rates, and centerbody positions to determine the throat Mach number in the inlet as a function of these parameters. This example illustrates that a Navier-Stokes procedure can be practically applied to the analysis of low speed inlet flows.

The 2-D/axisymmetric Navier-Stokes procedure of Peery and Forester⁽⁹⁾ was used to compute the desired inlet flows. Steady state solutions are obtained to the Navier-Stokes equations using an explicit time marching relaxation procedure. The analysis features the use of wall functions and zonal algebraic turbulence modeling for computational efficiency. Computed results for the Mach number distribution through the inlet with the centerbody fully retracted are shown in Figure 10 for free stream Mach numbers of 0. and 0.3. Note that with a static free stream Mach number the analysis predicts a lip separation and high throat flow distortion. At a free stream Mach number of 0.3, the lip separation has nearly disappeared and the throat flow is much more uniform. Work is underway on a mesh refinement study and the inclusion of a two equation turbulence model in the analysis. Detailed comparison of computed and measured flow properties through the inlet are planned when the test data becomes available.

Example - Supersonic Inlet at Transonic Speed - Flow interference between engine nacelles and an airframe has an important effect on the aerodynamic efficiency of an aircraft operating in the transonic speed regime. NASA conducted an extensive wind tunnel test program⁽¹⁰⁾ to evaluate aerodynamic performance penalties associated with the propulsion system installation in the NASA Ames 11x11 foot wind tunnel. The model used, Figure 11, is a .024 scale model of the 1971 U.S. SST. The model selected for the present example had sharp-lip flow-through nacelles. The mass flow through each nacelle could be controlled by means of a variable position exit plug.

In the low supersonic speed regime and with inlet capture mass flow ratios less than one (spillage), it was found that a panel potential flow method alone provides a poor simulation of the wing surface pressure distribution and thus a poor simulation of nacelle interference effects on lift, drag and pitching moments. An example flow was selected at a Mach number of 1.4 and a mass flow ratio of 0.8 to illustrate that a Navier-Stokes procedure can be used with a panel method to provide an improved simulation.

Kulfan⁽¹¹⁾ simulated the model flow field with the PANAIR panel method. As shown in Figure 12, Kulfan used the Navier-Stokes procedure of Peery and Forester⁽⁹⁾ in a small region near the inlet to predict the shock shape and location, local Mach number distribution and streamline pattern about the nacelle as a function of free stream Mach number and mass flow ratio through the inlet. The Navier-Stokes procedure was found to give an accurate simulation of the shock shape and stand-off distance for the range of upstream Mach numbers and mass flow ratios of interest, as shown in Figure 12. Kulfan then used the Navier-Stokes results to locate a stream tube about the nacelle where the flow on the stream tube surface was everywhere supersonic. As shown in Figure 13, Kulfan modified the PANAIR paneling to treat this stream tube as an inlet of larger diameter positioned further forward. The results of the PANAIR simulation, modified by the use of the Navier-Stokes procedure, are shown in Figure 14 for a Mach number of 1.4 and a capture mass flow ratio of 0.8. The new simulation gives a much improved prediction of the under surface pressure distribution.

Example - Supersonic Inlet at Cruise Speed - An axisymmetric mixed compression inlet similar to that shown in Figure 9 was tested at a Mach number of 2.65 as part of a NASA inlet technology development.⁽¹²⁾ The inlet features a translating centerbody and a traveling bleed system. This

example was selected to show that a very accurate simulation of at least some high speed inlet flows is possible and that this capability has been available for at least a decade.

Reyhner and Hickcox⁽¹³⁾ simulated this inlet flow with a procedure that uses method-of-characteristics to compute the core flow, a finite difference solution for the boundary layer development, and control volume analyses for the shock/boundary layer interactions. Boundary layer bleed is accounted for in the analysis as well as the displacement of the shock system due to viscous effects. With reference to the Historical Development section above, it should be noted that this analysis procedure was developed to support design of the inlet system for the American SST.

Comparisons between computed results and test data for the static pressure distributions on the cowl and centerbody are shown in Figure 15. Note that the combined flowfield solution procedure of Reyhner and Hickcox provides a very accurate simulation of the inlet static pressure distribution. The forward translation of the shock system due to viscous effects is also shown.

Comparisons between computed results and test data for boundary layer pitot profiles on cowl and centerbody surfaces at a number of axial locations are shown in Figure 16. The simulation accounted for boundary layer bleed and for shock/boundary layer interactions and agreement between computed results and test data is excellent. This good agreement is not accidental, as an extensive validation of each component of the overall analysis procedure was conducted before any attempt was made to construct the overall inlet analysis procedure.

PROBLEM AREAS

We are now progressively acquiring the capability to predict 3-D flows associated with inlets and with propulsion system installations in the subsonic, transonic and supersonic speed regimes. Geometry description has been and continues to be a problem in all speed regimes. Highly integrated blended installations imply geometries for which it is very difficult to obtain either an analytic description of the surface or the coordinates of points on the surfaces. The acquisition of an analytic surface representation or the surface coordinates are an essential step in the analysis of almost every flow of interest. Experience has shown that a substantial portion of the time spent in completing a given flow analysis is spent dealing with geometry.

Viscous flow phenomena are important in all speed regimes. With only a few exceptions, available turbulence models were developed for 2-D flow phenomena.⁽¹⁴⁾ These models are currently being used to simulate 3-D flows without adequate validation and thus achieving only a mixed degree of success. Data for modeling or validation of 3-D viscous phenomena are generally not available or are to a large degree inadequate. Detailed experimental investigations of the following flows are essential if we are to extend our present inlet flow analysis capability in the supersonic regime to include inlets at angle-of-attack and 3-D inlet geometries:

- o Glancing (3-D) shock/boundary layer interactions
- o Swept shock/boundary layer or shear layer interactions
- o BLC (bleed, V.G.'s, etc.) for 3-D boundary layers
- o Separation
- o Pressure driven secondary flows in ducts with offsets, diffusion and geometry variation

The final flow on this list is, of course, that of a subsonic diffuser with geometry variation and offset. This particular flow cries for a definitive experimental study because it is of current interest for many new military aircraft, especially those with an RCS constraint. As was shown above, procedures⁽⁶⁾ exist which will qualitatively predict such flows. Effective use of these procedures for design is impeded by the current lack of detailed data.

Great care must be taken in the interpretation of computed results for viscous flows. Turbulence modeling has in many instances become a catch-all for numerical truncation errors (inadequate mesh density and/or a bad mesh-algorithm interaction), residual errors (inadequate convergence) or a poor selection of boundary conditions. In too many instances, a mesh is selected on the basis of the available computer storage, the maximum number of iterations selected to satisfy a budget constraint, and any differences between computed and measured results attributed to the turbulence modeling. The high cost of computing 3-D flows with adequate numerics make the use of such erroneous procedures very attractive. We should be careful not to buy the "fools gold" of carelessly conducted and interpreted studies.

In the numerics area, although large class 6 computers are now becoming widely available, the high cost of computing many flows of practical interest impedes the use of CFD for inlet design. Experience indicates that the cost of acquiring design information analytically must be less than about 10% of the cost of an equivalent wind tunnel simulation if parametric analysis is to be considered for a design study. Formal methods need to be developed to define automatically the residual and truncation errors associated with a numerical procedure for a given mesh. The process of acquiring such information is at present very tedious and as noted above, the failure to conduct such studies has led to problems in the interpretation of computed results. Methods should be developed to adjust the grid adaptively to satisfy input limits on residual and truncation error.

Interest in computing aircraft/inlet flow interactions has focused attention on the use of zonal modeling techniques since such flows are generally beyond the capacity of the largest available computers with a single procedure. While zonal modeling makes the calculation of such flows possible by dividing the flow field of interest into subdomains each with an appropriate analysis (the PANAIR/Navier-Stokes coupling used in the nacelle interference example above), much work needs to be done to develop zonal modeling techniques for design. For many flows, solution domains must overlap and the solutions in the various subdomains must be iterated. The selection of subdomain boundaries, the handling of boundary conditions, mesh generation, interpolation of properties between non-coincident meshes in regions of overlap, and the acquisition of numerical error information as the solution progresses are all important questions to be answered if zonal strategies are to be utilized.

In many instances, the designer is not able to apply the available analysis capability effectively in a design study. Many flows that can be computed are difficult for even the experienced fluid analyst. How can a designer hope to compute such flows in the context of a design study? One possible method is to make available the analysis capability through a group of expert users. The designer doesn't expect the keys to the wind tunnel when he wants design information from an experimental study. He should also not expect the keys to the computer building when design information is wanted from an analysis study.

Another problem is that computer codes useful for design have not proven to be very portable as noted in a March 9, 1981 article in Business Week. Flow codes developed for industry by government or university researchers unfamiliar with the intended application are invariably deficient for design studies. Experience indicates that the intended user should work very closely with the code developer to ensure the code developed satisfies the user's needs. Progress in the use of analysis for design has been much slower than necessary because of the general failure of industry, government and university researchers to cooperate effectively to produce flow codes for design. Computer system differences and code requirements which vary from user-to-user contribute to the problem.

SUPERSONIC INLET FLOWS - CURRENT APPROACHES

A review of current analysis approaches to inlet flows in all speed regimes is beyond the scope of the present paper. Because inlets operating in the supersonic speed regime are of high current interest, a brief discussion of the more popular approaches to the analysis of these flows is included in the present article. Current approaches can be grouped into three categories:

- o Zonal modeling
- o Navier-Stokes
- o Space marching

Because these approaches are at different stages of development, conclusions as to the relative merits of the approaches are not drawn. An example and a discussion of each of these approaches follows below.

Zonal Modeling - As noted above, a zonal modeling strategy was used very successfully to develop an inlet system for the American SST. This procedure has been further developed and refined over the last decade as shown in Figure 17. The procedure was applied to the design of a Mach 3.5 axisymmetric mixed compression inlet and bleed system in the mid-1970's.⁽¹⁵⁾ The application of this procedure resulted in a detail definition of the bleed system geometry, such as number of bleed holes, hole size, hole spacing, and bleed exit area, for each individual bleed region. The bleed mass flows, bleed plenum pressures and the effect of the individual bleed regions on the boundary layer development were also predicted. These predictions were made not only at the design Mach number but across the entire started Mach number range. A wind tunnel test of a 1/3 scale model of the analytically designed inlet showed excellent agreement with the theoretical predictions, thus validating the analytical design procedure. Work is underway at Boeing to extend this analysis procedure to predict the flow of an axisymmetric mixed

compression inlet at angle-of-attack. This work, part of the NASA Supersonic Cruise Research program, was selected as an example of a zonal approach to a difficult supersonic inlet flow. The improved analysis will provide flow properties for inlet design, instrumentation definition and digital control system using a detailed inlet simulation in a model following controller concept and for control signal synthesis. It will also improve the inlet design and control procedures by allowing inlet performance to be computed at off design conditions.

The planned analysis for the inlet at angle-of-attack is illustrated in Figure 18. A 3-D method-of-characteristics program⁽¹⁶⁾ will be used for the core flow. Boundary layer and shock/boundary layer interaction programs are being developed for the viscous flow development through the supersonic diffuser. The 3-D parabolized Navier-Stokes procedure of Roberts and Forester⁽⁶⁾ will be used for the subsonic diffuser.

The NASA Mach 2.65 "P" inlet bleed system has been redesigned and the inlet instrumented and tested at a number of Mach number and angle of attack conditions to provide validation data for the overall analysis procedure, when complete. Detailed experimental studies of the swept and normal shock/boundary layer interactions have been proposed to NASA and a detailed experimental study of the subsonic diffuser will be proposed.

The asymmetry of the shock structure in an axisymmetric mixed compression inlet at angle-of-attack is shown in Figure 19. Note the substantial modification of the shock structure induced by a small (3°) angle-of-attack at Mach 3.0. The shock structure at angle-of-attack was computed with the 3-D method-of-characteristics program.⁽¹⁶⁾

Navier-Stokes - A numerical procedure under development by Knight⁽¹⁷⁾ for the simulation of 2-D mixed compression inlet flows for the Air Force was selected as an example of a Navier-Stokes approach. Knight's analysis solves the compressible Navier-Stokes equations using the explicit finite difference operator of MacCormack. The method features an algebraic eddy viscosity turbulence model and a body fitted mesh system. Boundary layer bleed is accounted for in the analysis. The method has been validated for flat plate boundary layer and 2-D shock/boundary layer interaction flows.

Knight⁽¹⁸⁾ applied this two-dimensional procedure to a rectangular high speed inlet investigated experimentally by Carter and Spong.⁽¹⁹⁾ As shown in Figure 20, the model consisted of a supersonic diffuser formed by two plates at an angle to one another followed by a constant area throat. The upper and lower surfaces were considered analogous to ramp and cowl surfaces of a high speed inlet. The "cowl" plate was hinged to permit variation of the cowl angle, δ_c . Boundary layer bleed was used on the ramp and cowl surfaces and on the inlet sideplates to control the boundary layer development on these surfaces.

A comparison between computed results and experimental data for the cowl and ramp surface pressure distributions is presented in Figure 20. For this case, the free stream Mach number was 3.5 and δ_c was 6° . Good agreement was obtained between computed and measured static pressure for the first shock interactions on both the ramp and cowl surfaces. The analysis substantially underpredicts the static pressure rise through the second and third shock

interactions on the ramp and through the second shock interaction on the cowl. The analysis also appears to "smear" the static pressure distribution in the vicinity of these interactions.

A comparison between computed and measured pitot profiles on the ramp and cowl surfaces is presented in Figure 21. Good agreement was obtained for the stations reported.

This analysis required several hours CPU time on a Cyber 175 computer. Work is underway to vectorize the algorithm for the NASA Langley STAR computer which should substantially reduce the cost of the analysis.

Space Marching - A 3-D numerical procedure by Buggeln et al⁽²⁰⁾ was selected as an example of a space marching analysis. In this analysis, a primary flow direction is assumed and diffusion in that direction is neglected. The simplified equations which retain the viscous stress terms are solved using a marching procedure. The analysis features the use of a curvilinear orthogonal coordinate system and a mixing length turbulence model. The total enthalpy is assumed constant through the solution region to avoid solving an energy equation.

Anderson and Towne⁽²¹⁾ applied the analysis to a two-dimensional (rectangular) inlet configuration, Figure 22, at Mach 3.0. This inlet flow, at a high Reynolds number, had a complex internal shock structure and a large "core" of inviscid flow. Anderson ran three mesh densities for the inlet. The finest mesh had over 70,000 grid point, however, only six mesh planes were used between the sidewall and the symmetry plane. The total computing time on a UNIVAC 1100/42 was about 3 hours for the finest mesh.

Computed Mach number profiles for coarse and medium mesh solutions are shown in Figure 22. The predicted shock system appears to move forward as the mesh is refined. A comparison between computed and measured cowl and ramp static pressure distributions is shown in Figure 23. Good agreement was obtained for both meshes with the experimental data.

Each of the above procedures under development for analysis of supersonic inlet flows offers advantages and disadvantages. The advantages of the zonal approach are that it is well understood, very efficient, and it is usually easy to sort out cause and effect relationships in a design study. This usually means deciding whether to change the contours or the bleed system for optimum performance. Disadvantages are that a complex coupling of the component analyses is required, the analysis is restricted in application to only a few types of geometries, and a number of flow phenomena of practical interest cannot typically be predicted (local separation or a local subsonic pockets).

The advantages of the Navier-Stokes procedures are that modeling of complex viscous-inviscid interactions is unnecessary and that no restrictions (theoretically) are placed on the flow phenomena or geometries which can be computed. Major disadvantages are the high cost, difficulty in recognizing and controlling numerical errors, the difficulty of applying the analysis successfully, and the difficulty in making "bleed vs geometry" modification decisions.

The potential advantages of space marching procedures are that complex viscous inviscid interactions don't have to be modeled and that only a few restrictions (no separation) are placed on flows or geometries which can be analyzed. While this approach is less developed than the others, the computing costs reported are disappointing. The method also appears to position the shocks at shock/boundary layer interactions too far downstream. Whether this can be corrected by mesh refinement (or other means) remains to be determined.

PROMISING DEVELOPMENTS

Events which should lead to a significant improvement in our present inlet flow analysis capability are:

- o 1980-81 AFOSR-HTTM-Stanford Conference on Complex Turbulent Flows
- o New schemes to improve the efficiency of numerical solution procedures
- o Wide availability of Class 6 computers

The Stanford Conference will make available a number of data sets reviewed and selected by the leading experimentalists to support either improved modeling or code validation. Current numerical procedures and turbulence models will be applied to these data. The computed results will be evaluated to gain insight into where further modeling or experimental work is required. The Stanford Conference could be a significant step toward improved modeling of 3-D viscous flow phenomena. A strategy should, however, be developed so that improved modeling of 3-D flows of interest is not left to chance.

Tremendous progress has been reported recently toward the development of algorithms which could reduce the cost of computing difficult flows down to a level practical for design. These include implicit algorithms, self adaptive meshes, and multigrid schemes. Automated numerical error assessment is essential if we are to make much of the present analysis capability available for design.

Class 6 computers are now commercially available. Vectorization of existing algorithms on these computers has resulted in about an order-of-magnitude reduction in the CPU time necessary for a given problem. The large fast core available on these machines implies that greater mesh densities or larger flow regions can be computed than before. The combination of the new large computers and improved numerical algorithms should lead to a substantial improvement in the range of flows which can be computed as well as a marked reduction in the cost of computing a given flow.

CONCLUSIONS AND RECOMMENDATIONS

There is an increasing trend toward the use of parametric analysis rather than parametric testing for inlet design. This trend, driven by the high cost of wind tunnel testing, is expected to continue. We can, at present analyze many 2-D and some 3-D inlet flows. Many of the available flow analyses are, however, not being utilized for design. The high skill level required to successfully apply many existing flow analyses effectively blocks their use for design.

Greater care must be taken to ensure that computed flow properties are not contaminated with numerical errors. Analyses should be applied only to those flow phenomena for which they have been validated. Adequate experimental validation data for many flows (especially 3D flows) of current interest is not available.

REFERENCES

1. Tjonneland, E., "The Design, Development and Testing of a Supersonic Transport Inlet System,"
2. Syberg, J. and Koncsek, J. L., "Low Speed Tests of a Fixed Geometry Inlet for a Tilt Nacelle V/STOL Airplane," NASA Contract Report NASA CR-151922, January 1977.
3. Forester, C. K., "Body Fitted 3-D Full Potential Flow Analysis of Complex Ducts and Inlets," AIAA Paper 81-0002, presented to the 19th Aerospace Sciences Meeting, January 12-15, 1981.
4. Kowalski, E. J., "Boundary Fitted Coordinate Systems For Arbitrary Computational Regions," Workshop on Grid Generation, NASA Langley Research Center, October 6-7, 1980.
5. MacMiller, C. J., "Investigation of Subsonic Duct Distortion," AFFDL-TR-69-21, 1969, pp. 218-221.
6. Roberts, D. W., and Forester, C. K., "Parabolic Procedure for Flow in Ducts with Arbitrary Cross-Sections," AIAA J., V. 17, No. 1, pp. 33-40, January 1979.
7. Thompson, J. F., Thames, F. C., and Mastin, C. W., "Automatic Numerical Generation of Body Fitted Curvilinear Coordinate System for Field Containing Any Number of Two-Dimensional Bodies," J. of Computational Physics, V. 15, 1974, pp. 299-319.
8. Syberg, J. and Turner, L., "Supersonic Test of a Mixed Compression Axisymmetric Inlet at Angles of Incidence," NASA CR 165686, April 1981.
9. Peery, K. M. and Forester, C. K., "Numerical Simulation of Multi-Stream Nozzle Flows," AIAA J., V. 18, No. 9, September 1980, pp. 1088-1093.
10. Bencze, D. P., "Wind Tunnel Investigation of Nacelle Airframe Interference of Mach Numbers of 0.9 to 1.4", NASA TMX-62, 489, 73, 147, 088, 3321; 1976-1977.
11. Kulfan, R. M. and Sigalla, A., "Airframe Propulsion System Aerodynamic Interference Predictions at High Transonic Mach Numbers Including Off-Design Engine Airflow Effects," AGARD Symposium on Aerodynamics of Power Plant Installation, Toulouse, France, May 1981.
12. Koncsek, J. L. and Syberg, J., "Transonic and Supersonic Test of a Mach 2.65 Mixed Compression Axisymmetric Intake," NASA CR-1977, March 1972.

13. Reyhner, T. A. and Hickcox, T. E., "Combined Viscous-Inviscid Analysis of Supersonic Inlet Flowfields," AIAA J. of Aircraft, V. 9, No. 8, August 1972, pp. 589-595.
14. Birch, S. F., "Turbulence Models - Progress and Problems," Computer Methods in Fluids, Pentech Press Ltd., 1980, pp. 285-307.
15. Syberg, J. and Koncsek, J. L., "Experimental Evaluation of a Mach 3.5 Inlet," NASA Cr-2563, July 1975.
16. Vadyak, J. and Hoffman, J. D., "Calculation of the Flowfield in Supersonic Mixed-Compression Inlets at Angle-of-Attack using the Three-Dimensional Method of Characteristics with Discrete Shock Wave Fitting," NASA CR-135425, June 1978.
17. Knight, D. D., "Improved Calculation of High Speed Inlet Flows. Part 1: Numerical Algorithm," AIAA J., V. 19, No. 1, January 1981, pp. 34-41.
18. Knight, D. D., "Improved Calculation of High Speed Inlet Flows. Part II: Results," AIAA J., V. 19, No. 2, February 1981, pp. 172-179.
19. Carter, T. D. and Spong, E. D., "High Speed Inlet Investigation. Vol. I: Description of Program and Results. Vol. II: Data Summary," AFFDL-TR-77-105, November 1977.
20. Buggeln, R. C., Kreskovsky, J. P. and McDonald, H., "Computation of Three-Dimensional Viscous Supersonic Flow in Inlets," AIAA paper 80-0194, January 1980.
21. Anderson, B. H. and Towne, C. E., "Numerical Simulation of Supersonic Inlets Using a Three-Dimensional Viscous Flow Analysis," AIAA Paper 80-0384

DESIGN PROCEDURES FOR PROPULSION INSTALLATIONS

TO DEVELOP A GIVEN DESIGN CONCEPT ...

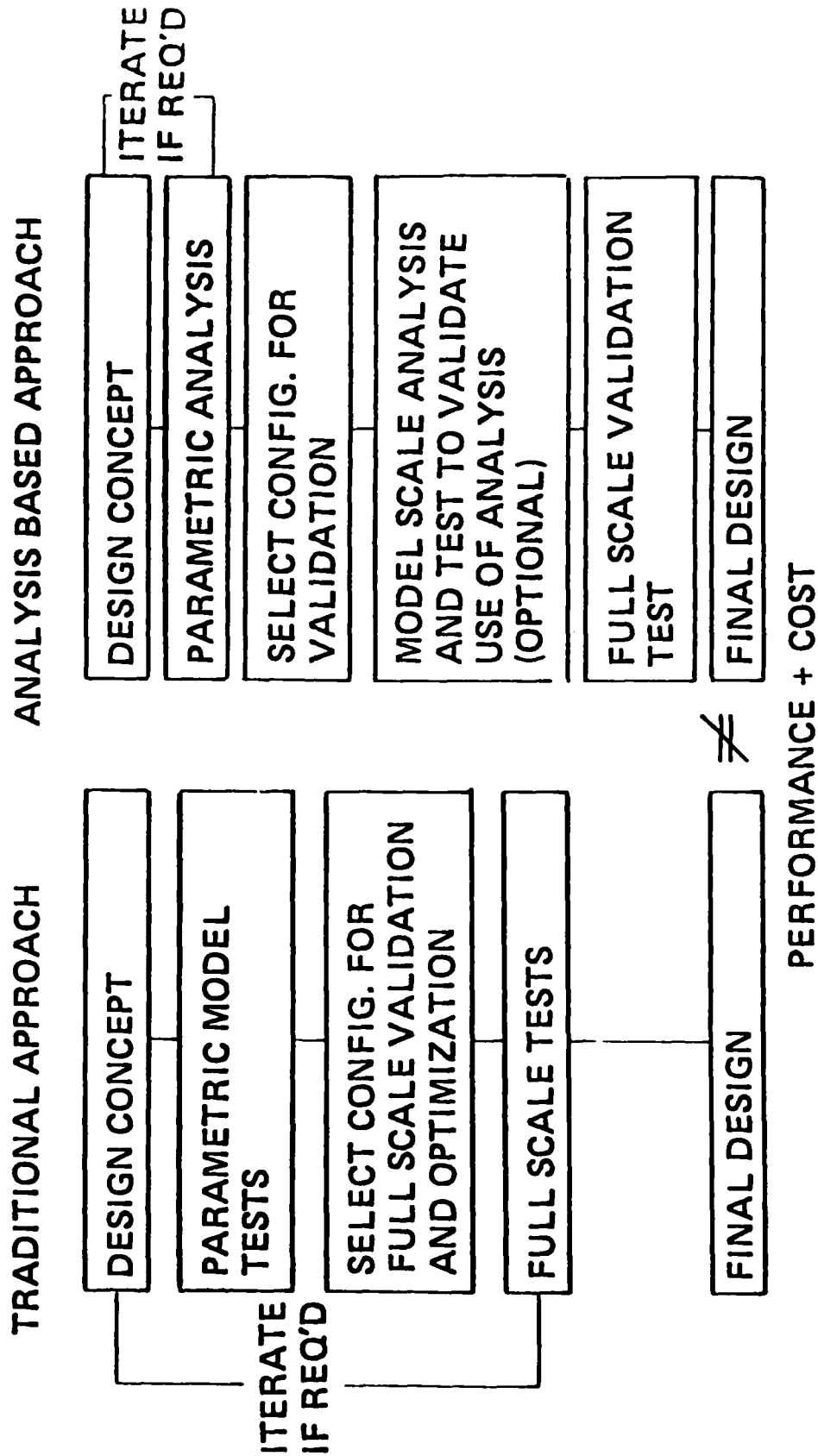

FIGURE 1.



FIGURE 2. ADVANCED AIRCRAFT CONCEPTS



EVOLUTION OF THE INLET DESIGN PROCEDURE

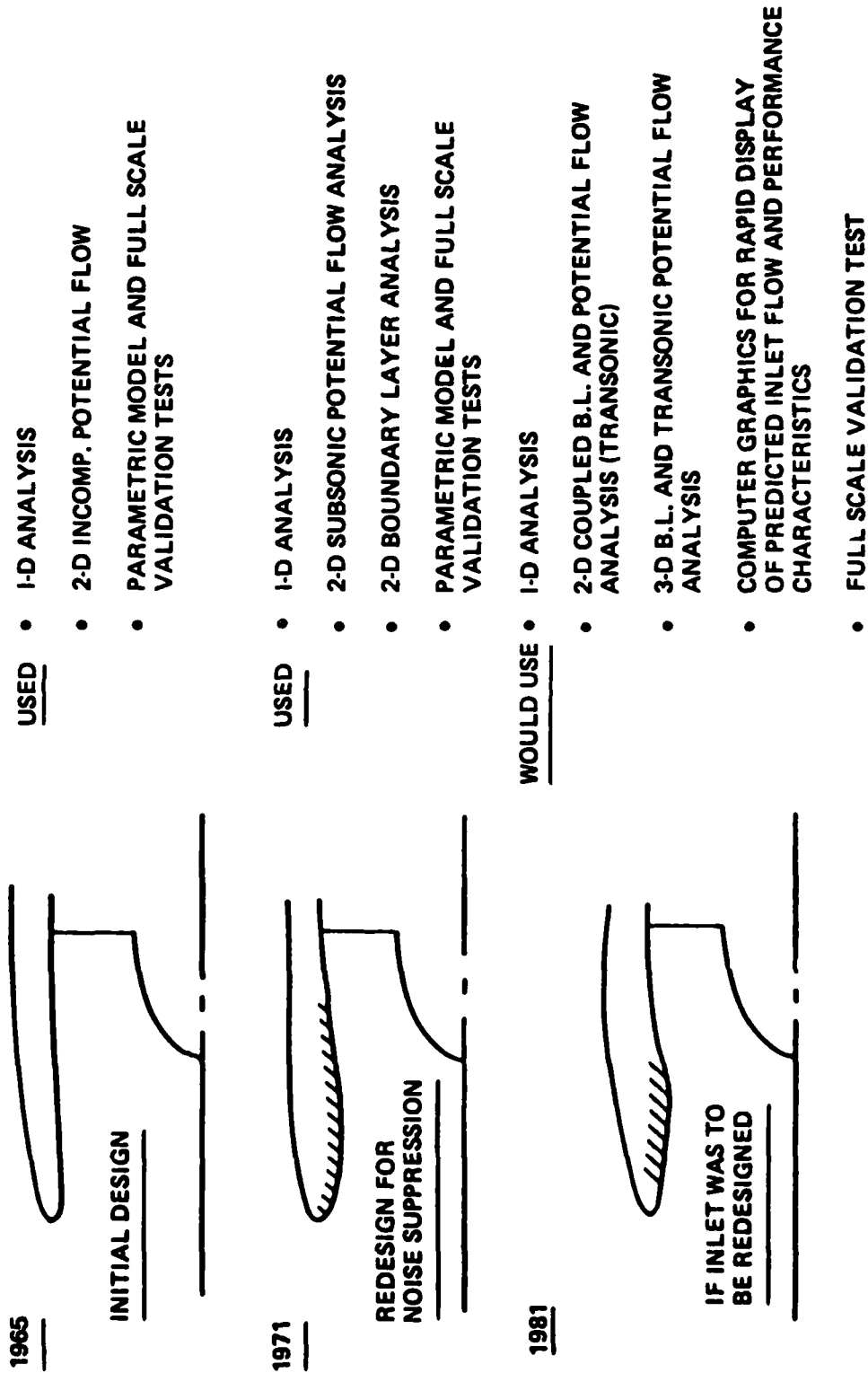

FIGURE 3.

Historical Development Numerical Fluid Mechanics

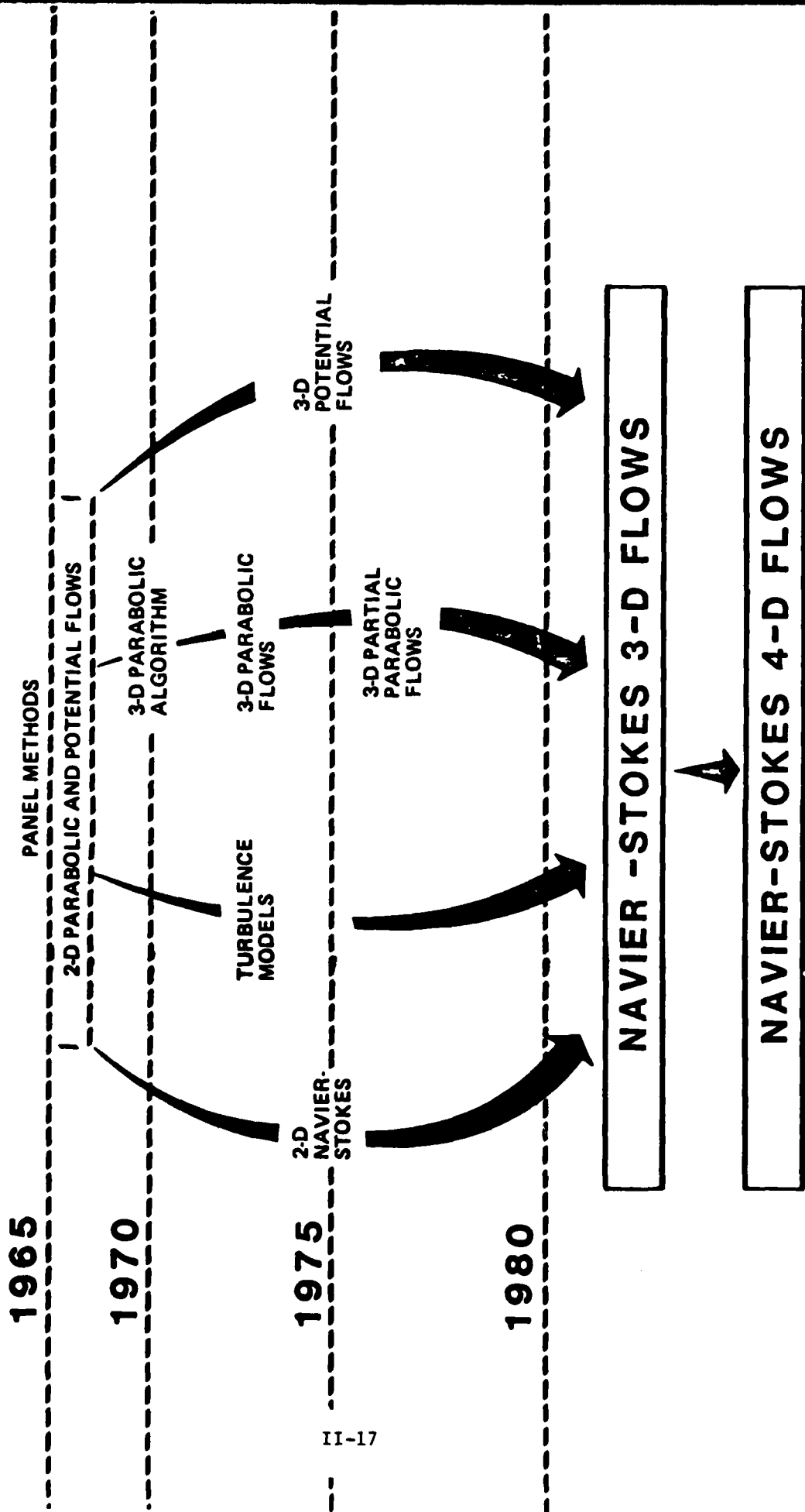

FIGURE 4.

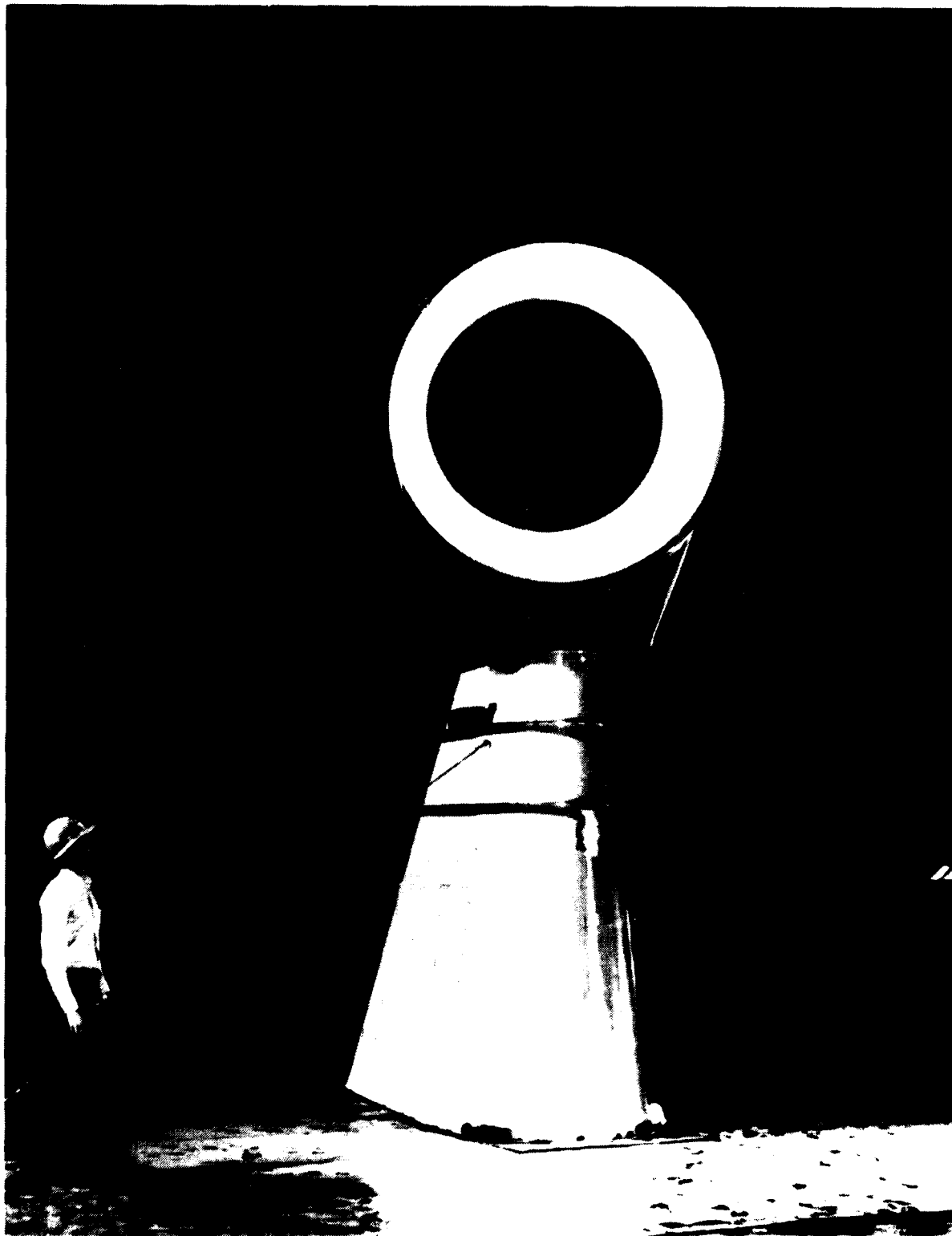

FIGURE 5. **Asymmetric V/STOL Inlet Model**

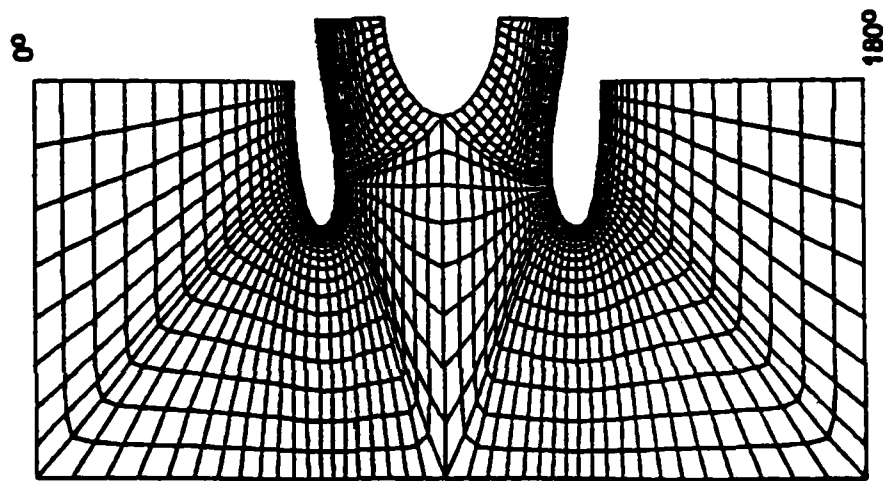

FIGURE 6. THE COMPUTATIONAL MESH

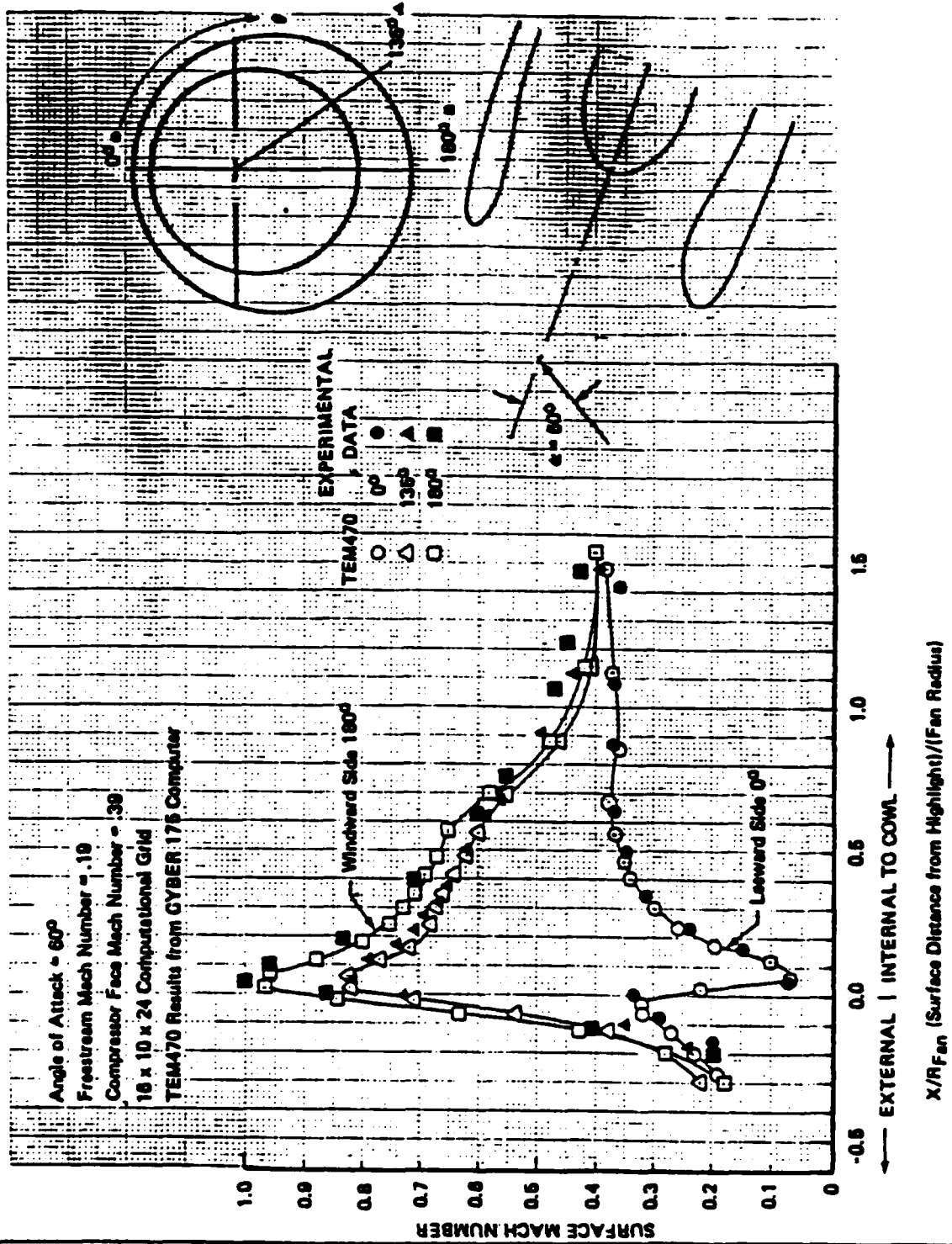

FIGURE 7.

CALC	EJK	REVISED	DATE	Cowl Surface Mach Number Distribution for an Asymmetric V/STOL Airplane Inlet.	Figure 7.
CHECK					
APPD					PAGE
APPD					

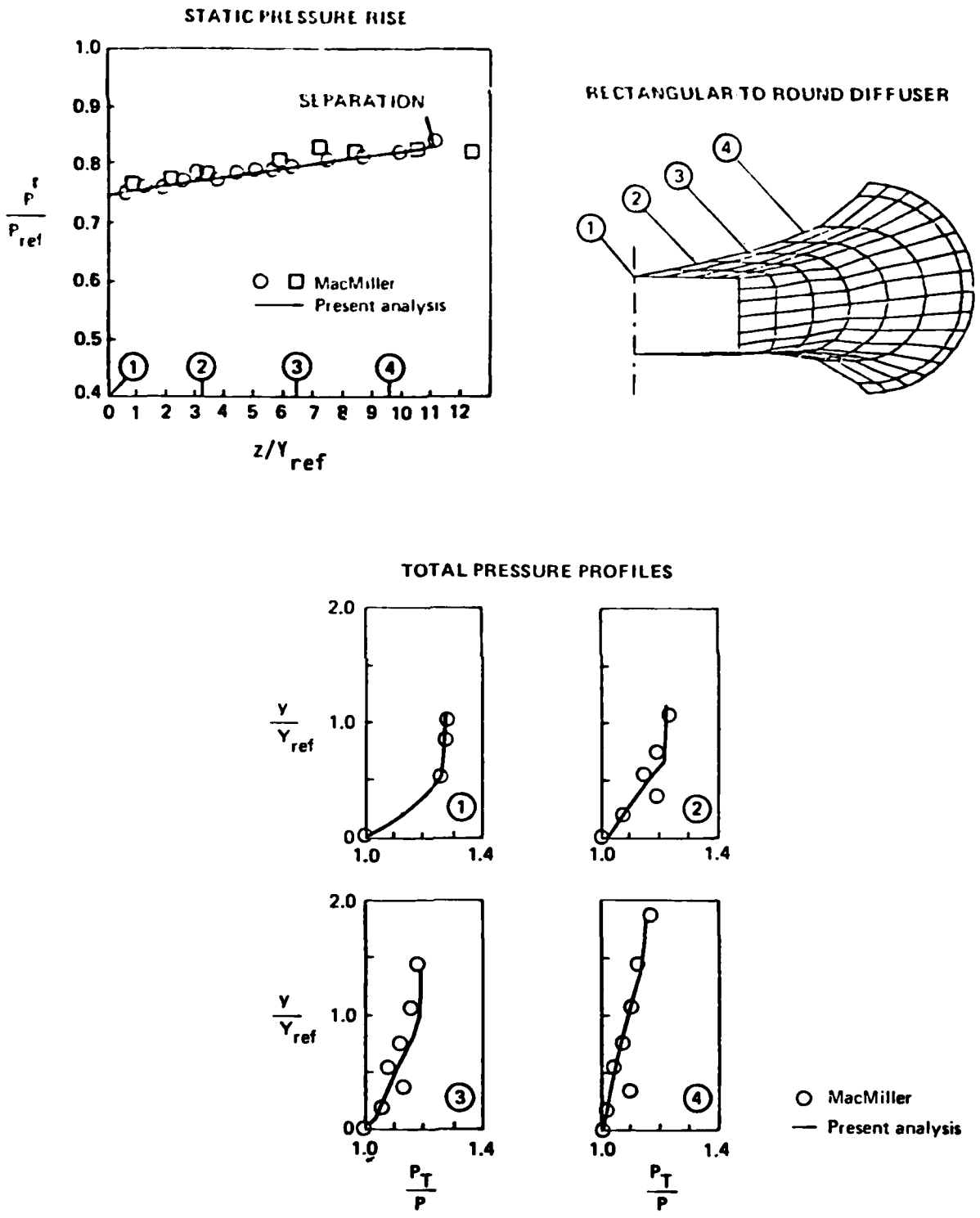

Figure 8. Analysis Results for a Diffuser With a Cross-Section Geometry Transition

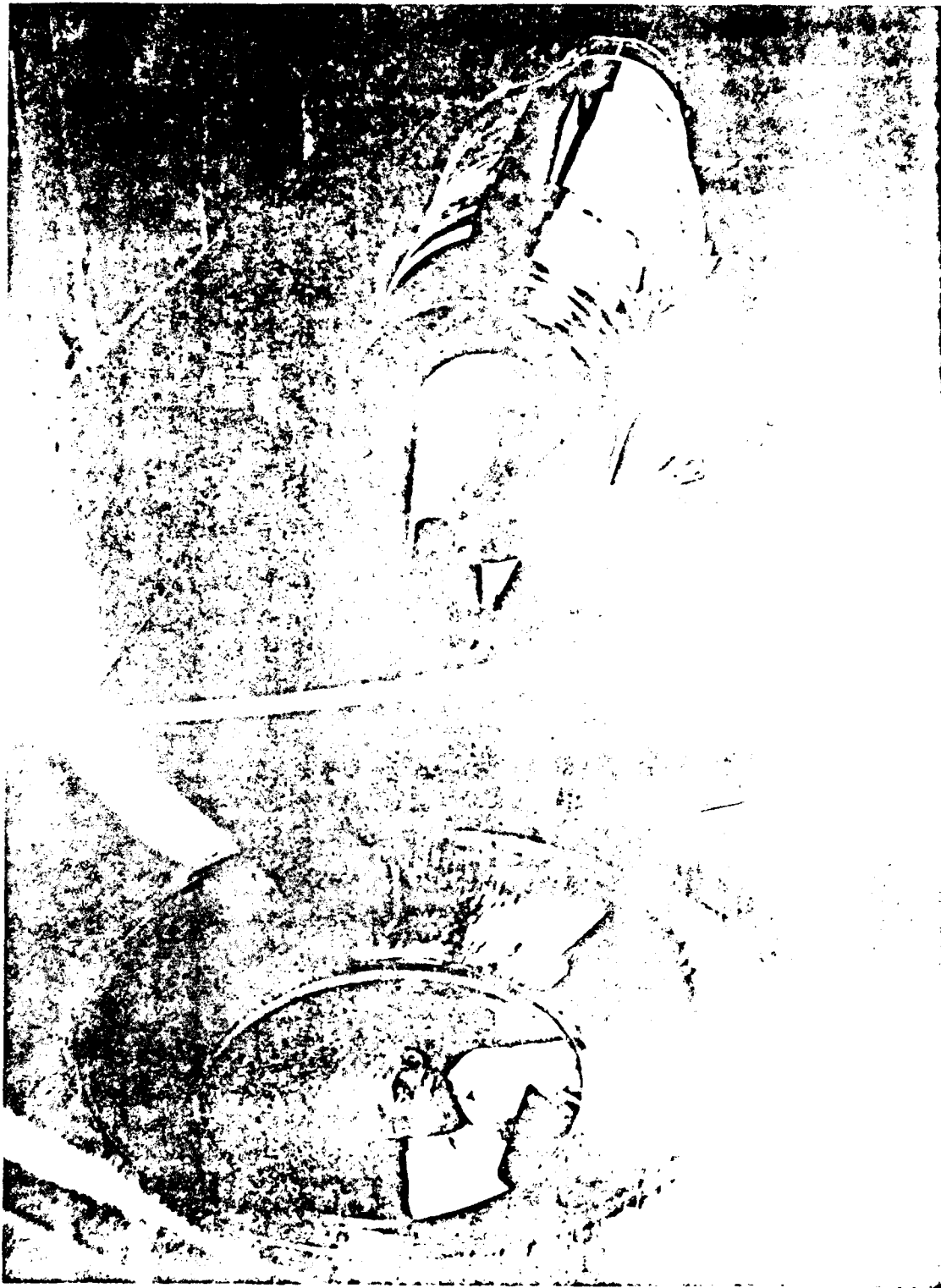
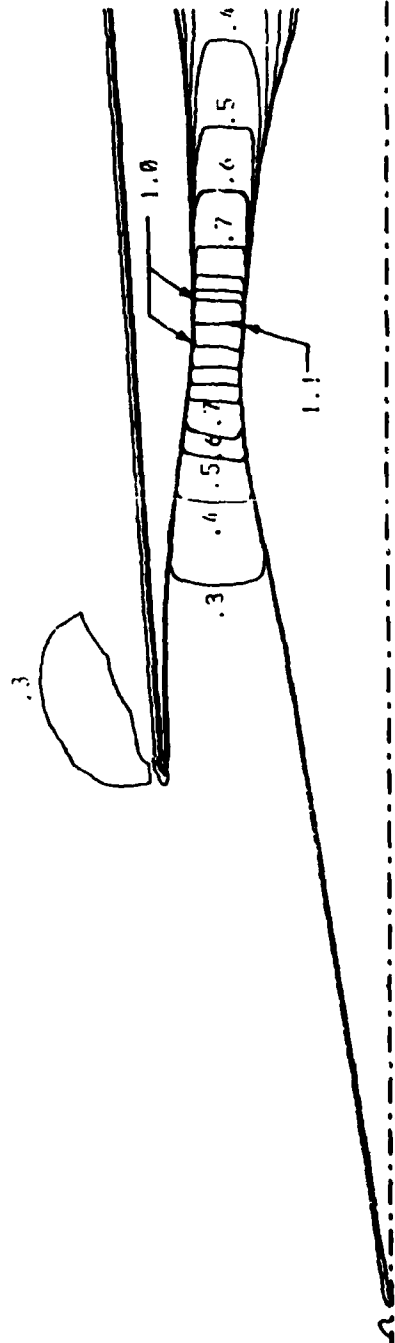

Figure 9, P-Inlet Installed in NASA-Lewis 10- by 10-ft Supersonic Wind Tunnel

Supersonic Cruise Inlet Mach Number Profiles

Noise Abatement Mode—Spike Fully Retracted

MACH = 0.3



II-23

MACH = 0.0

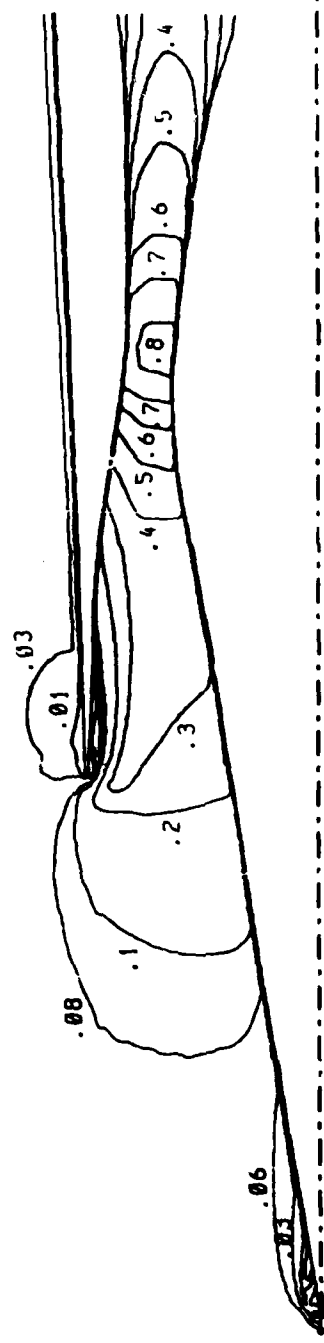

BOEING

FIGURE 10.

NASA NACELLE AIRFRAME INTERFERENCE WIND TUNNEL MODEL

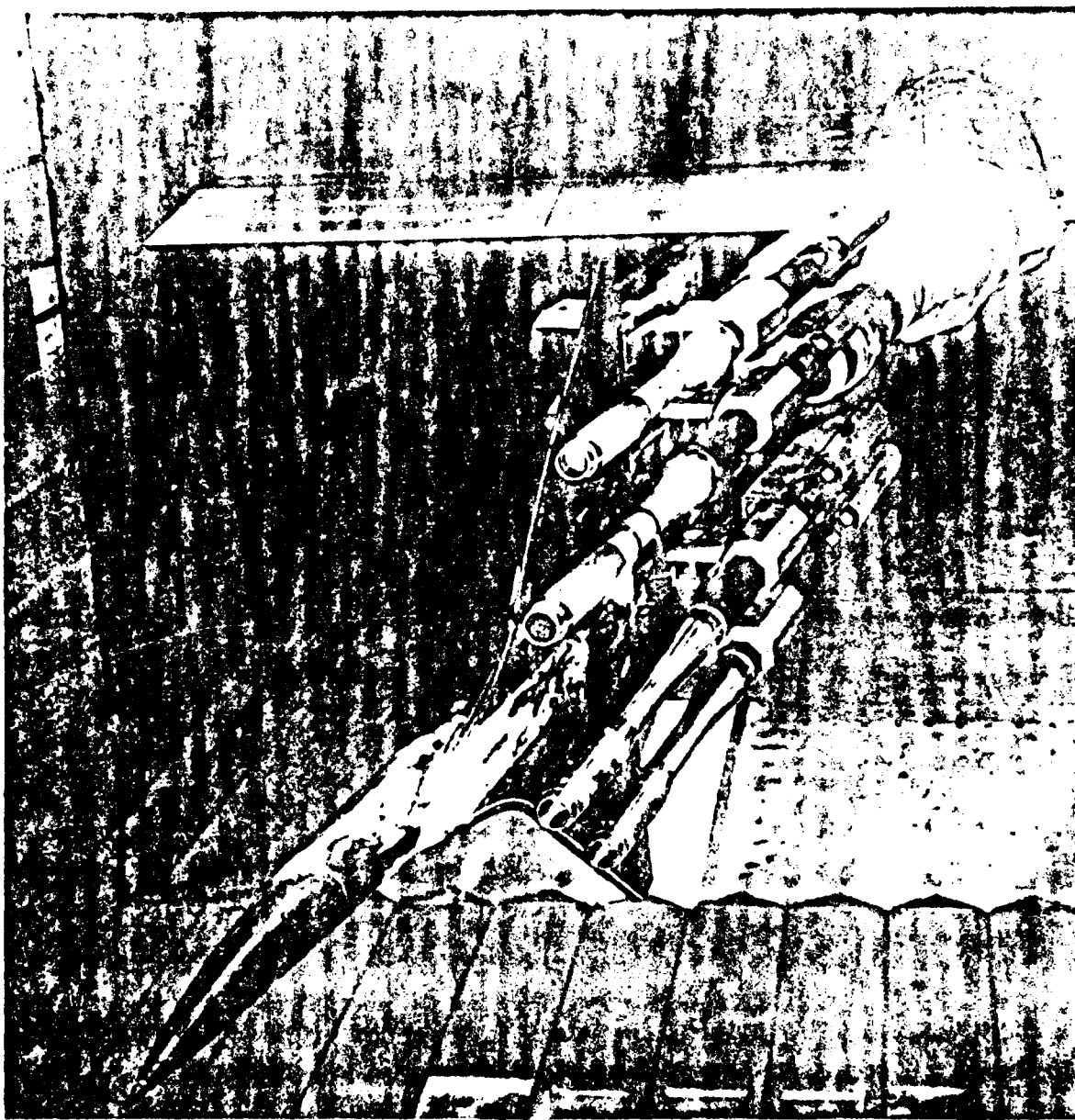

FIGURE 11.

VERIFICATION OF THE MIXED-FLOW THEORY

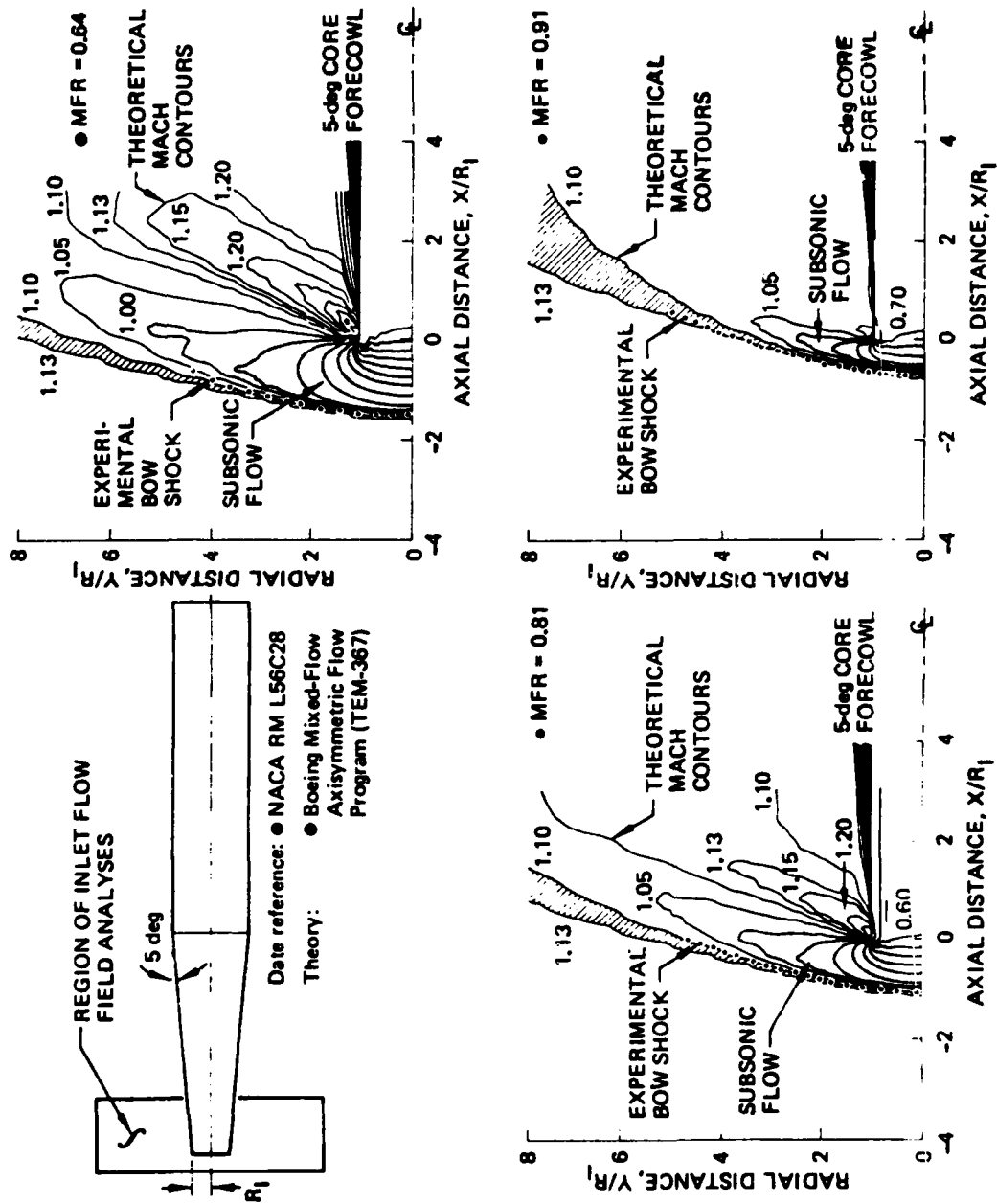

FIGURE 12.

COMPARISON OF PREDICTED BOW-SHOCK SHAPES FOR MASS-FLOW RATIOS OF 0.7 AND 0.8 AT MACH 1.4

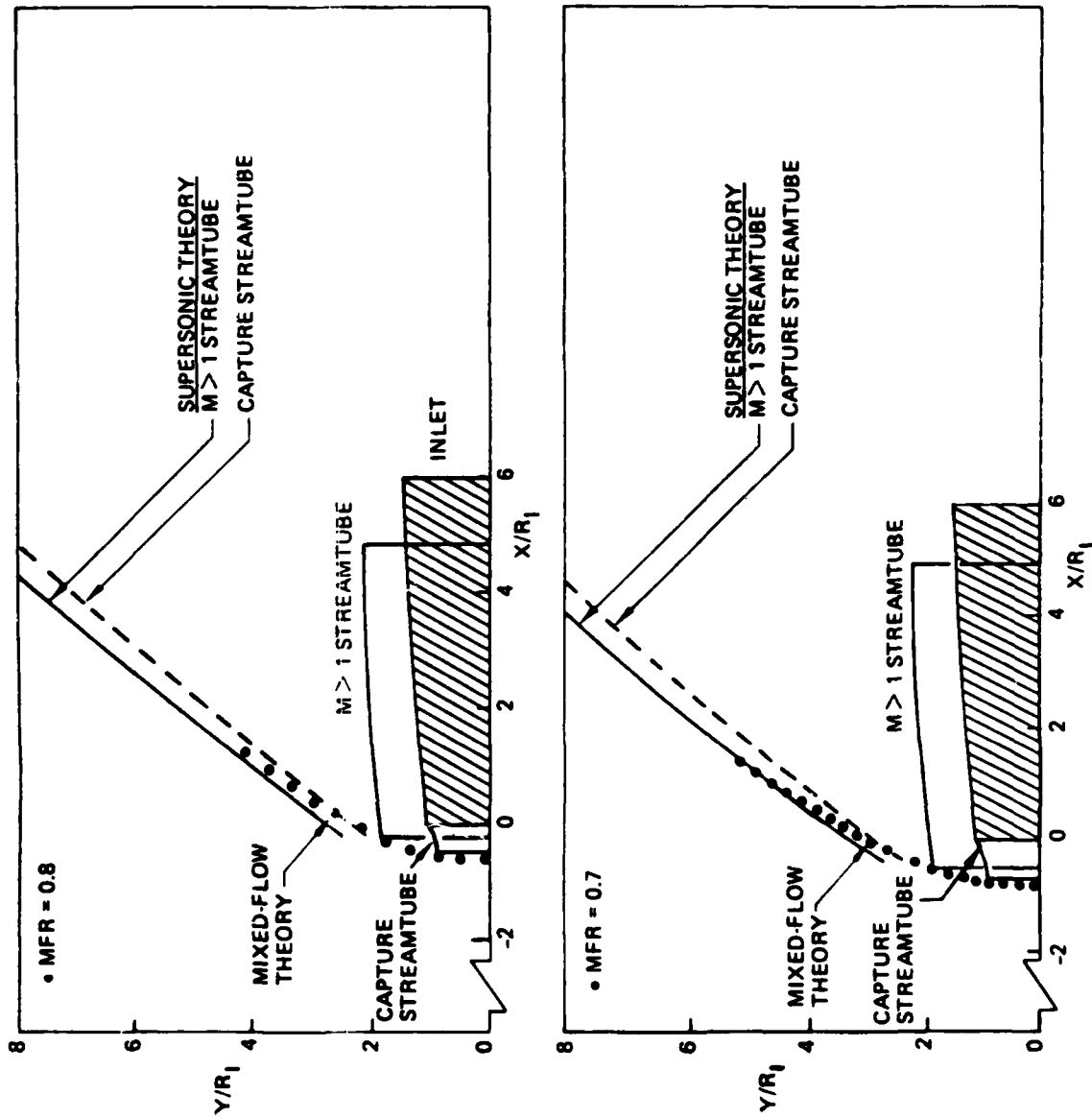

FIGURE 13.

EFFECT OF NORMAL-SHOCK SPILLAGE ON ISOLATED NACELLE PRESSURES & WING LOWER SURFACE PRESSURES AT MACH 1.4, ZERO ANGLE OF ATTACK, & A MASS FLOW RATIO OF 0.8

THEORY: SUPERSONIC THEORY WITH
CAPTURE STREAMTUBE
PSEUDO-NACELLE GEOMETRY

Interference Pressures: $MFR \approx 0.8$

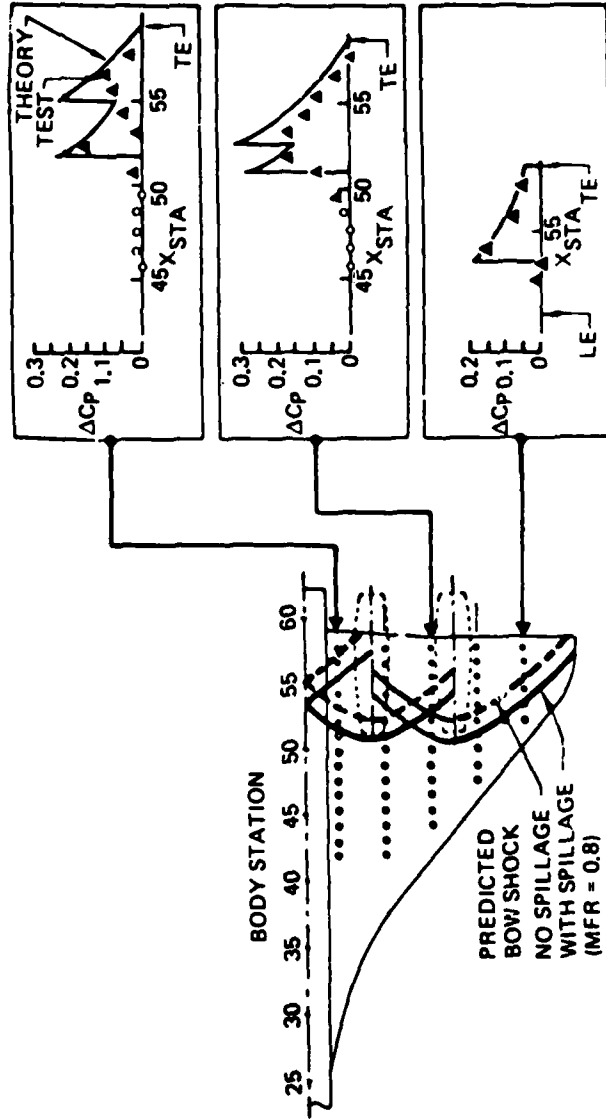
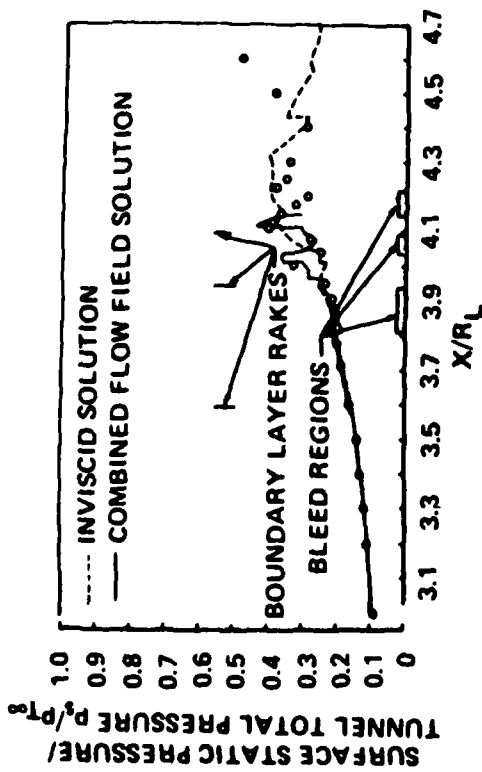
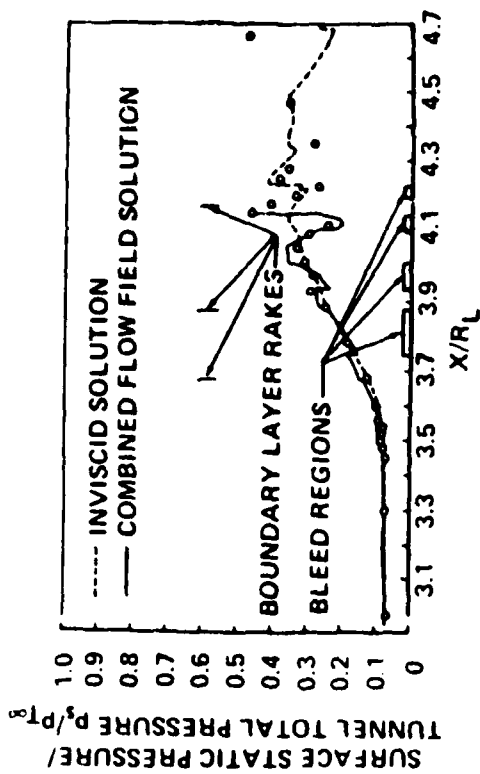

FIGURE 14.

Comparison of analytic predictions with experiment for cowl static pressure distribution (Ref. 6, $M_x = 2.65$.)



82-II-28



Comparison of analytic predictions with experiment for centerbody static pressure distribution (Ref. $M_x = 2.65$.)

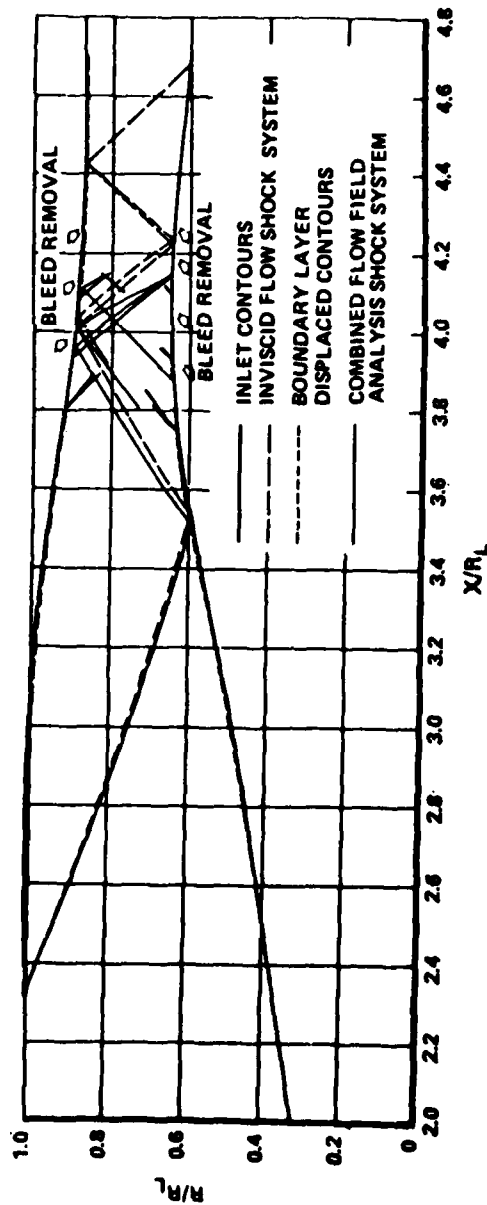

Comparison between inviscid flow and Combined Flowfield Analysis predictions for shock and expansion wave locations (Ref. $M_x = 2.65$.)

FIGURE 15. COWL AND CENTERBODY PRESSURE DISTRIBUTIONS FOR A MACH 2.65 AXISYMMETRIC INLET

Comparison of predicted boundary layer with experimental results (Ref. $M_r = 2.65$).

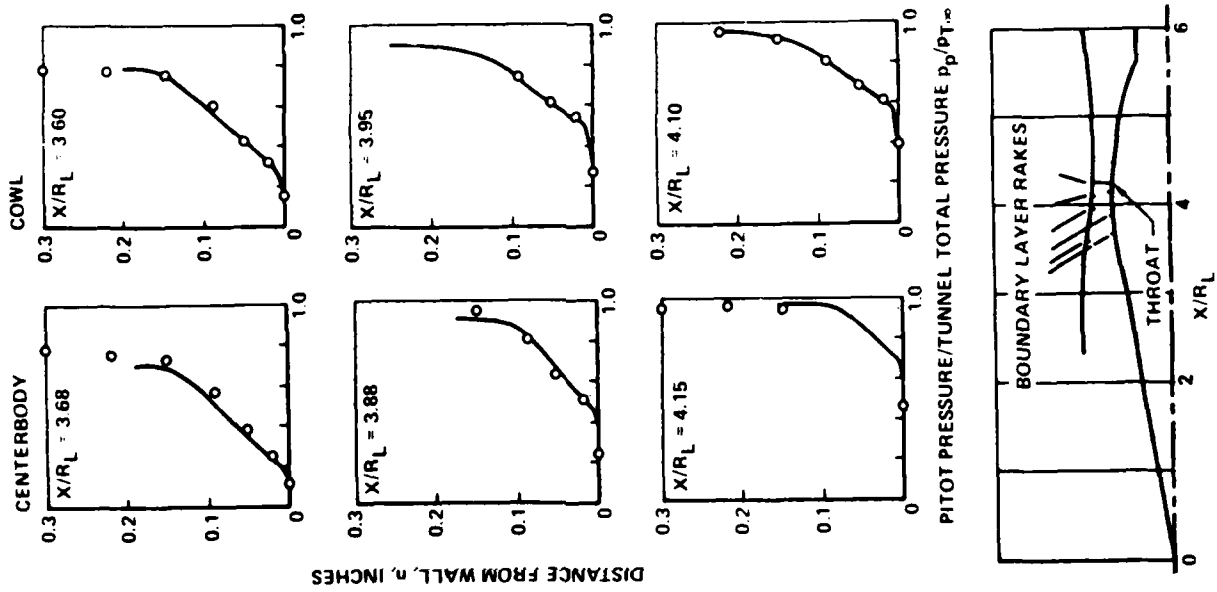

FIGURE 16.



Boeing Supersonic Inlet Technology Programs

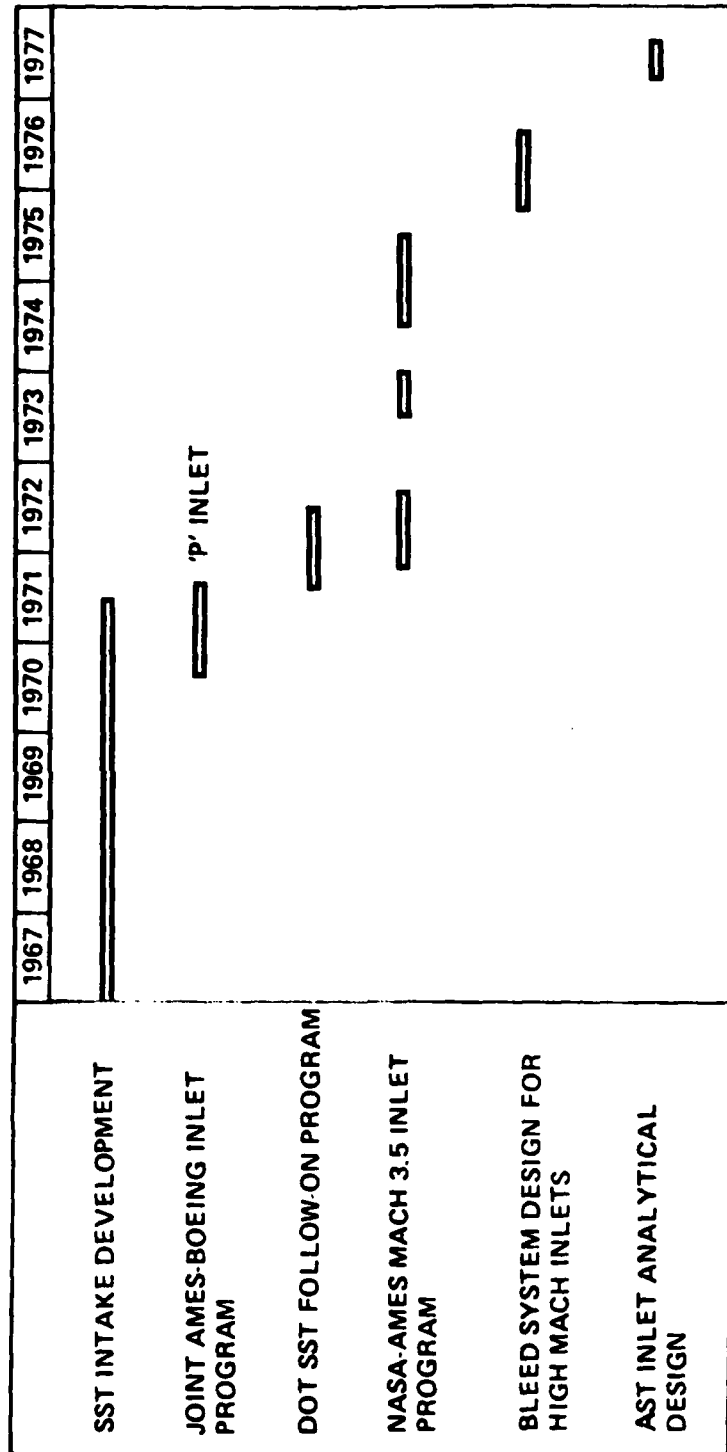

FIGURE 17.

BOEING

• : • : •



Analysis of Inlet Flow at Off-Design

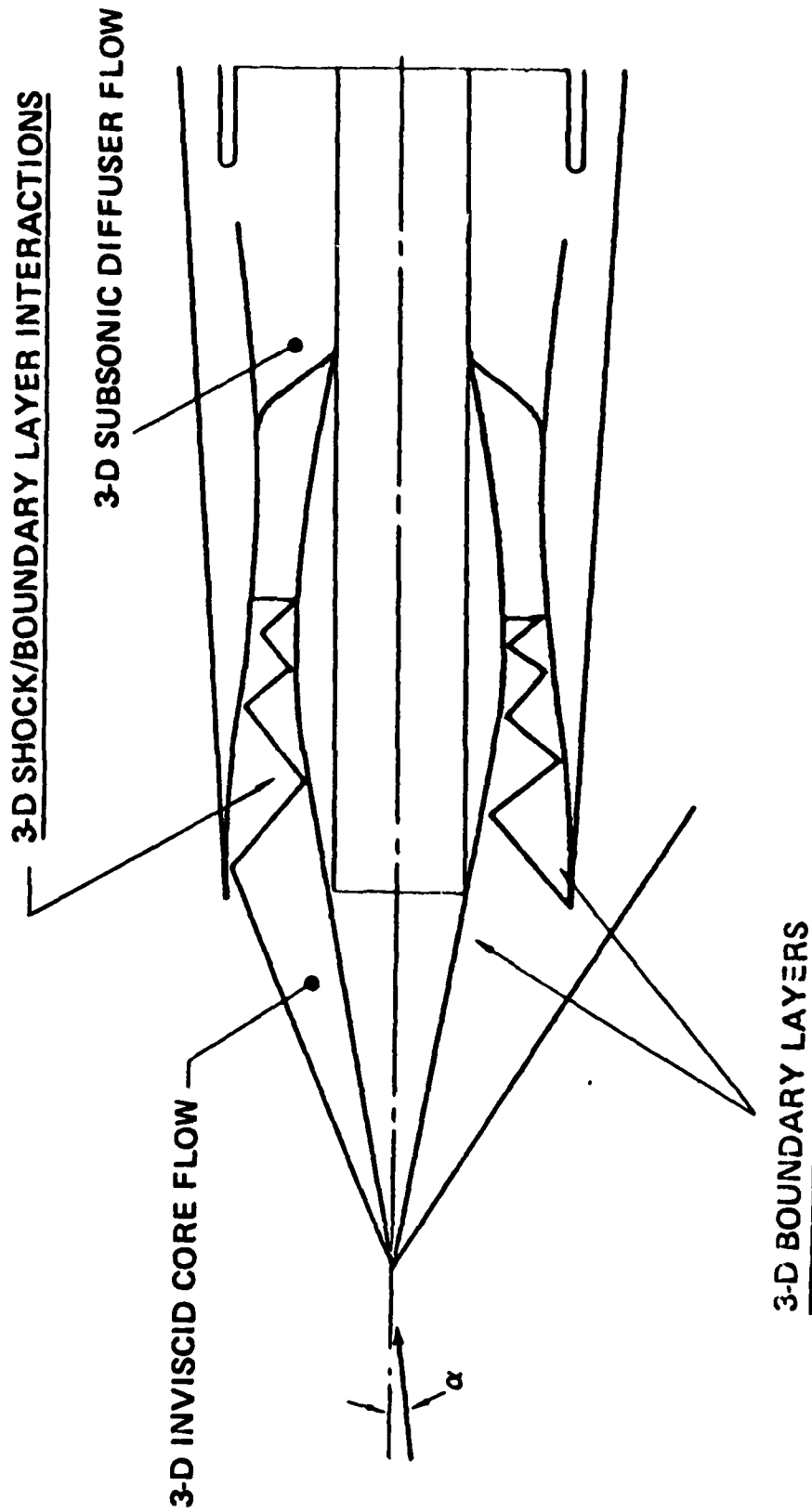

II-31

BOEING

FIGURE 18.

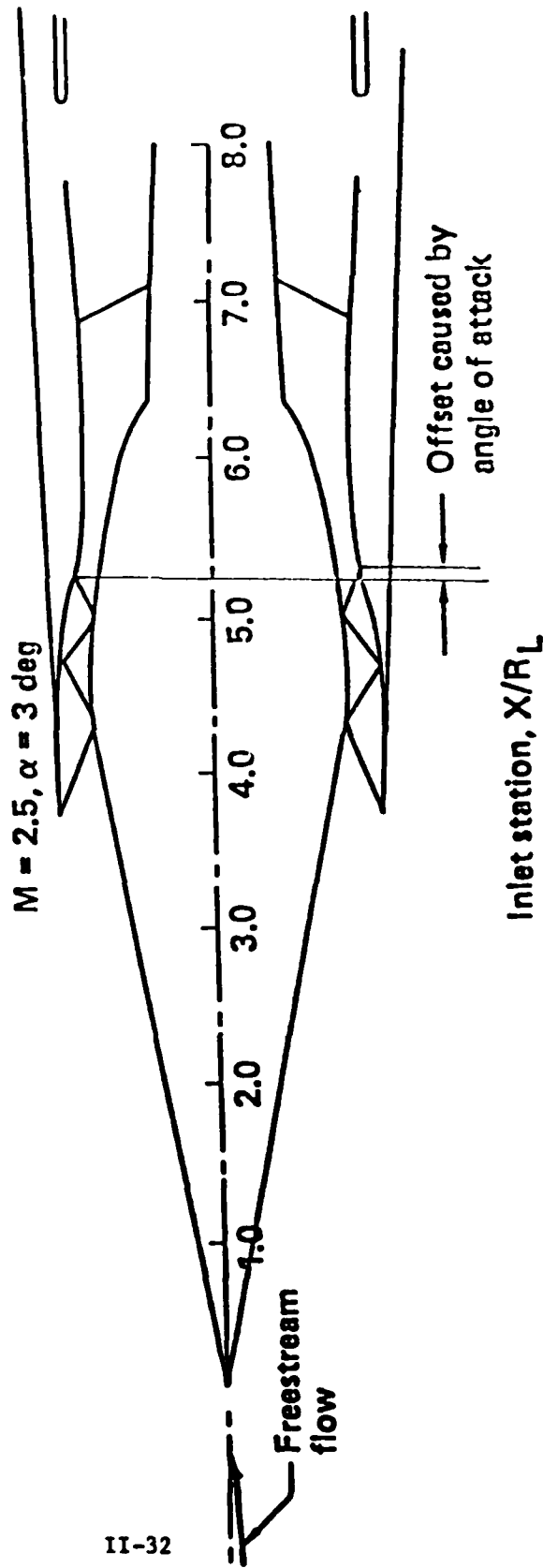

11-32

FIGURE 19. SHOCK LOCATION PREDICTION-METHOD OF CHARACTERISTICS

11-32

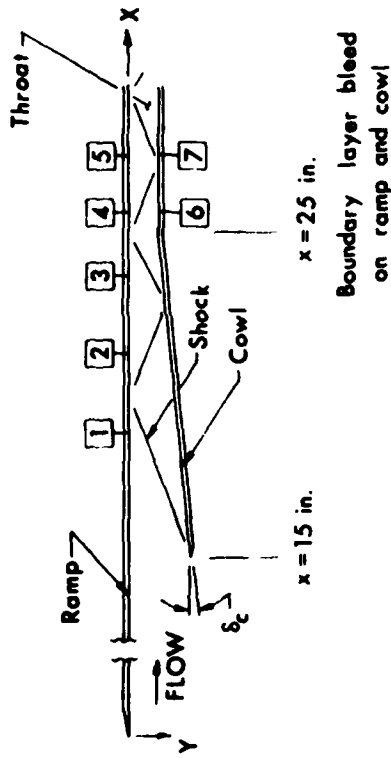

Geometry of High Speed Inlet

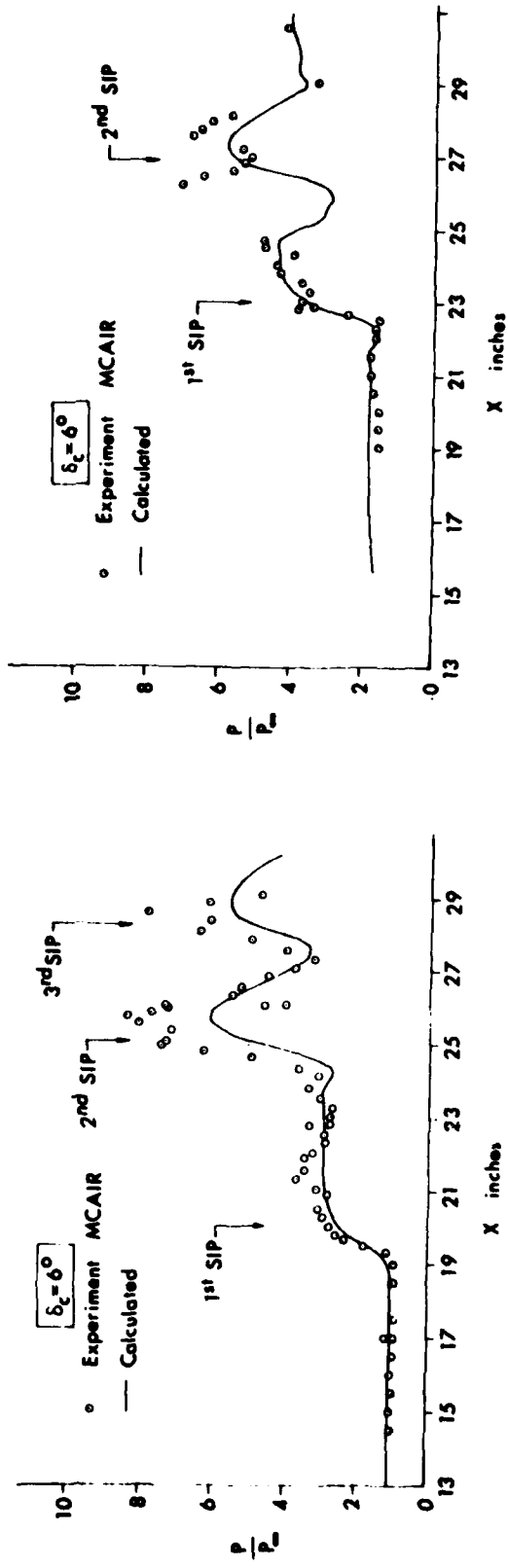
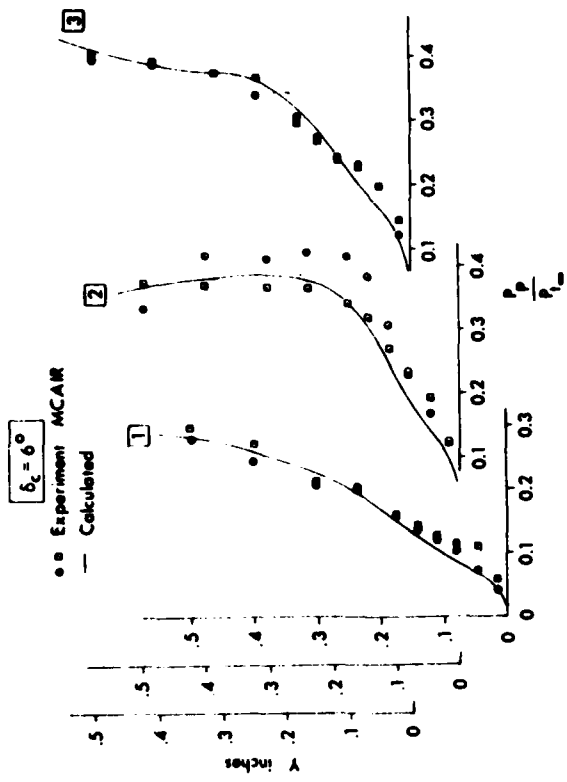
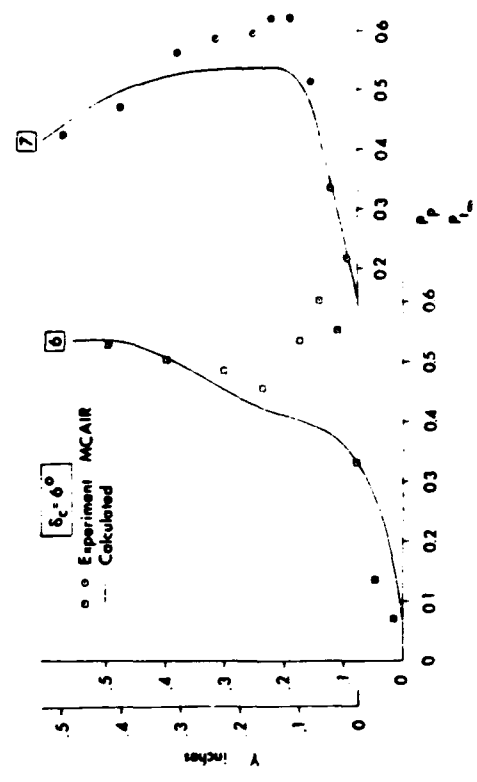

FIGURE 20. INLET STATIC PRESSURE DISTRIBUTIONS USING A NAVIER-STOKES ANALYSIS



Pitot Pressure Profiles on Ramp at Stations 1 through 3 for $\delta_c = 6^\circ$



Pitot Pressure Profiles on Cowl at Stations 6 and 7 for $\delta_c = 6^\circ$

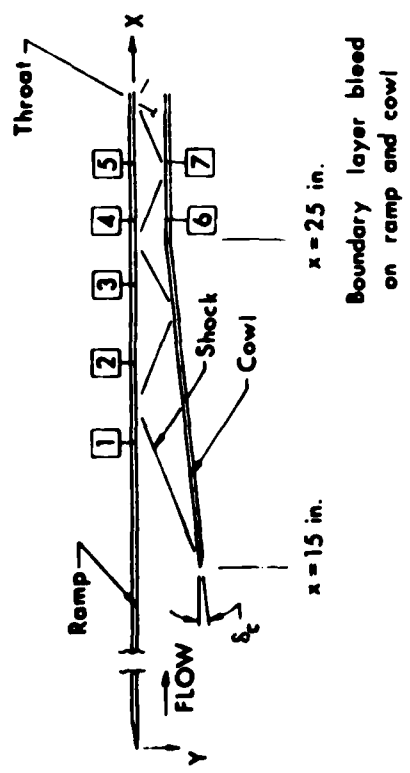

Geometry of High Speed Inlet

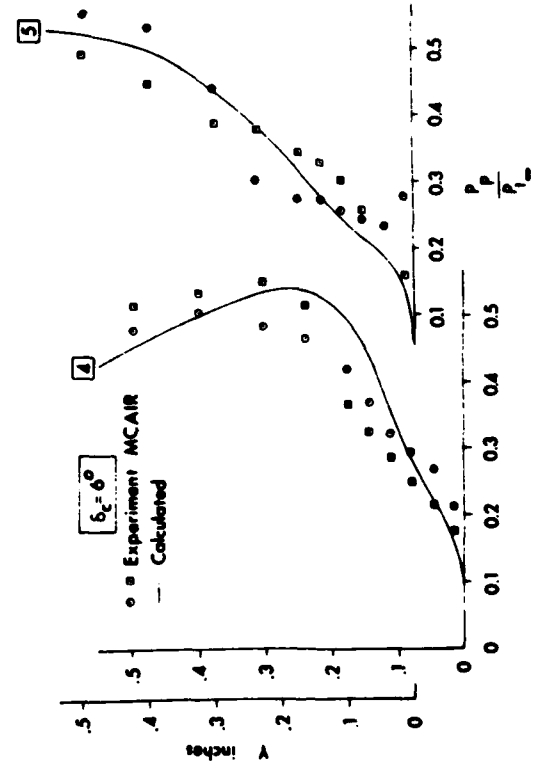

Pitot Pressure Profiles on Ramp at Stations 4 and 5 for $\delta_c = 6^\circ$

FIGURE 21. INLET BOUNDARY LAYER DEVELOPMENT USING A NAVIER-STOKES PROCEDURE

FIGURE 22. - Schematic diagram of M3 inlet configuration showing inviscid shock structure.

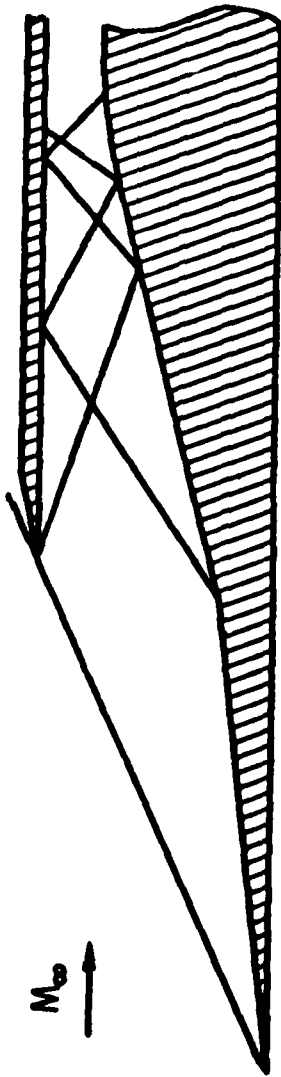

COMPARISON OF COARSE AND MEDIUM MESH USED IN COMPUTATION OF M3 INLET FLOW FIELD

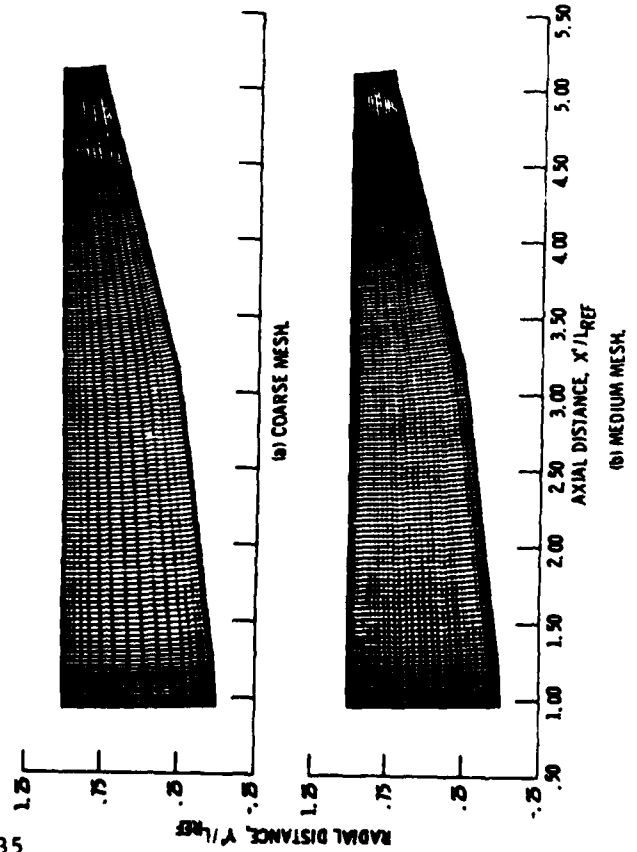

MACH NO. PROFILES IN CENTER PLANE OF M3 INLET CONFIGURATION $M_\infty=3.0$, $RE=7.2 \times 10^6 / m$ ($2.2 \times 10^6 / ft$)

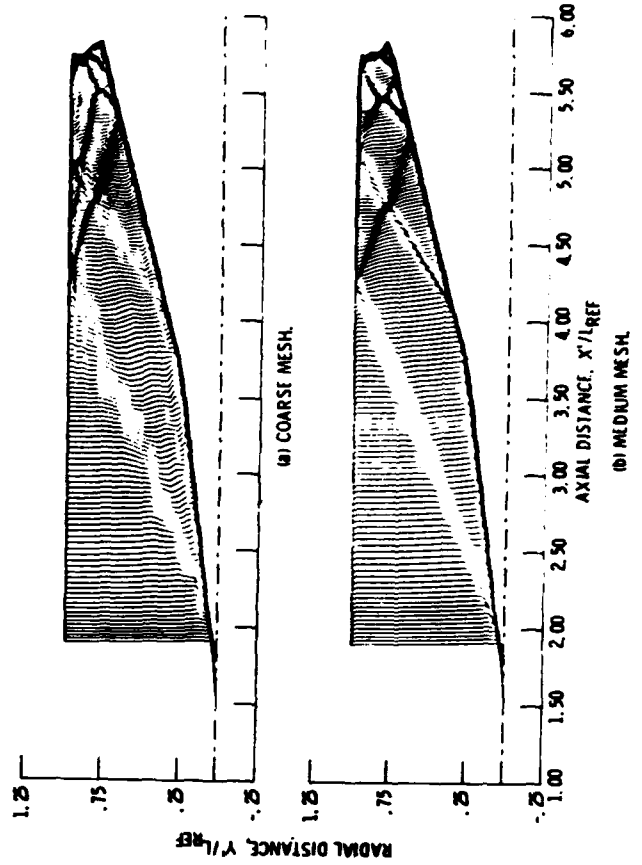

- Schematic diagram of M3 inlet configuration showing inviscid shock structure.

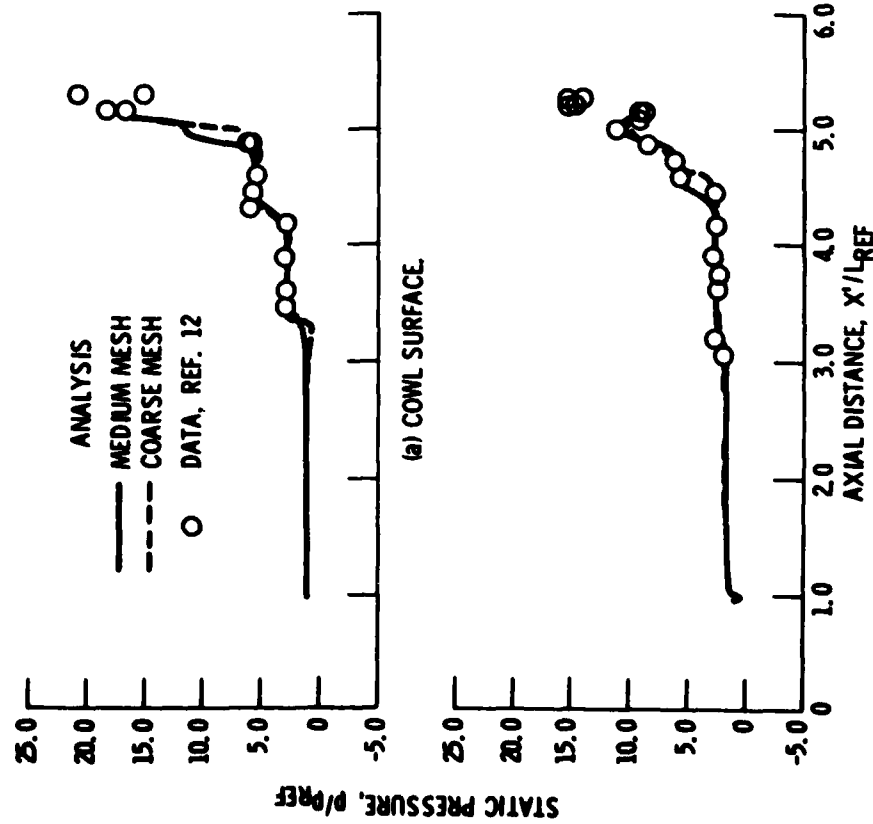
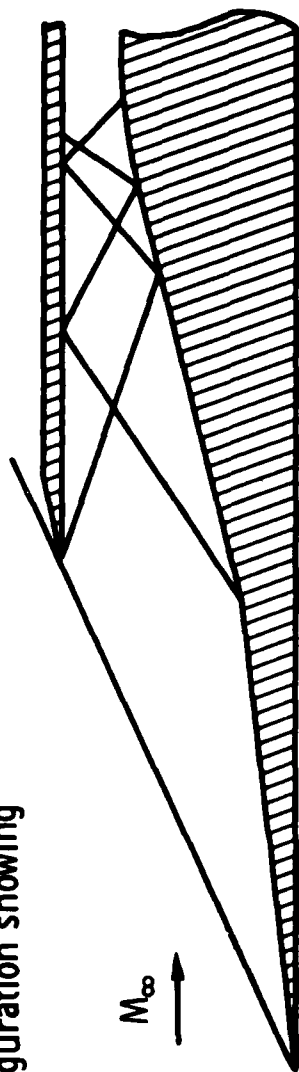

- Effect of mesh on the wall static pressure distribution in center plane of M3 inlet configuration.

FIGURE 23.

