

AD-A111 843

ARNOLD ENGINEERING DEVELOPMENT CENTER ARNOLD AFS TN F/G 14/2
FLOW FIELD INVESTIGATIONS OF A SIMULATED WEAPONS CAVITY AT MACH—ETC(U)
DEC 81 W A CROSBY

UNCLASSIFIED

AEDC-TSR-81-V37

NL

1 of 1
AD-A111 843

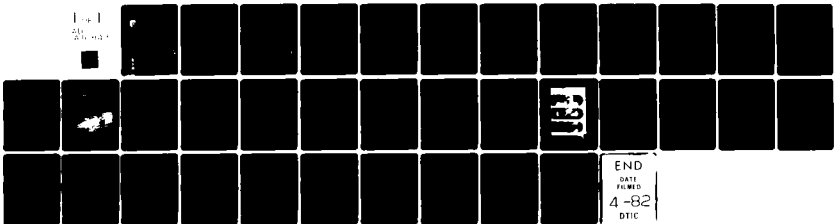

END
DATE
FILMED
4-82
DTIC

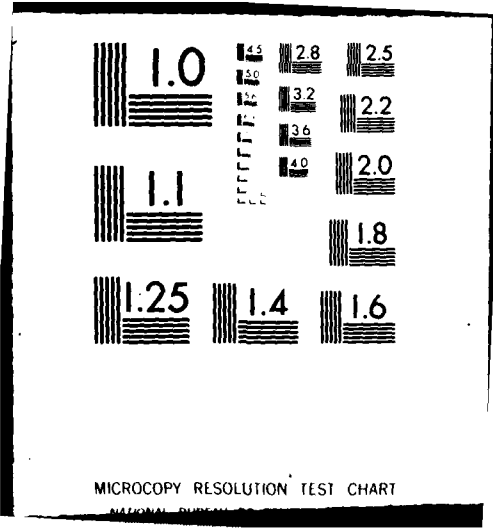

MICROCOPY RESOLUTION TEST CHART

NATIONAL BUREAU OF STANDARDS-1963-A

AEDC-TSR-81-V37

2

FLOW FIELD INVESTIGATIONS OF A
SIMULATED WEAPONS CAVITY AT MACH 3

W. A. Crosby
Calspan Field Services, Inc.



AD A111843

November 1981

Final Report for Period 27 October 1981

Approved for public release; distribution unlimited.

SDTIC
ELECTE
MAR 10 1982
H D

ARNOLD ENGINEERING DEVELOPMENT CENTER
ARNOLD AIR FORCE STATION, TENNESSEE
AIR FORCE SYSTEMS COMMAND
UNITED STATES AIR FORCE

82 03 09 029

FILE COPY

NOTICES

When U. S. Government drawings, specifications, or other data are used for any purpose other than a definitely related Government procurement operation, the Government thereby incurs no responsibility nor any obligation whatsoever, and the fact that the Government may have formulated, furnished, or in any way supplied the said drawings, specifications, or other data, is not to be regarded by implication or otherwise, or in any manner licensing the holder or any other person or corporation, or conveying any rights or permission to manufacture, use, or sell any patented invention that may in any way be related thereto.

References to named commercial products in this report are not to be considered in any sense as an endorsement of the product by the United States Air Force or the Government.

This report has been reviewed by the Information Office (OI) and is releasable to the National Technical Information Service (NTIS). At NTIS, it will be available to the general public, including foreign nations.

APPROVAL STATEMENT

This report has been reviewed and approved.

J. J. Best

J. T. BEST
Aeronautical Systems Branch
Deputy for Operations

Approved for publication:

FOR THE COMMANDER

John M. Rampy
JOHN M. RAMPY, Director
Aerospace Flight Dynamics Test
Deputy for Operations

UNCLASSIFIED

SECURITY CLASSIFICATION OF THIS PAGE (When Data Entered)

REPORT DOCUMENTATION PAGE		READ INSTRUCTIONS BEFORE COMPLETING FORM
1. REPORT NUMBER AEDC-TSR-81-V37	2. GOVT ACCESSION NO. AD-7111743	3. RECIPIENT'S CATALOG NUMBER
4. TITLE (and Subtitle) FLOW FIELD INVESTIGATIONS OF A SIMULATED WEAPONS CAVITY AT MACH 3		5. TYPE OF REPORT & PERIOD COVERED Final Report 27 October 1981
		6. PERFORMING ORG. REPORT NUMBER
7. AUTHOR(s) W. A. Crosby, Calspan Field Services, Inc.		8. CONTRACT OR GRANT NUMBER(s)
9. PERFORMING ORGANIZATION NAME AND ADDRESS Arnold Engineering Development Center Air Force Systems Command Arnold Air Force Station, TN 37389		10. PROGRAM ELEMENT, PROJECT, TASK AREA & WORK UNIT NUMBERS Program Element 61101F Control Number 0100
11. CONTROLLING OFFICE NAME AND ADDRESS AFWL/NTSAC Kirtland Air Force Base, NM 87117		12. REPORT DATE December 1981
		13. NUMBER OF PAGES 33
14. MONITORING AGENCY NAME & ADDRESS (if different from Controlling Office)		15. SECURITY CLASS. (of this report) UNCLASSIFIED
		15a. DECLASSIFICATION/DOWNGRADING SCHEDULE N/A
16. DISTRIBUTION STATEMENT (of this Report) Approved for public release; distribution unlimited.		
17. DISTRIBUTION STATEMENT (of the abstract entered in Block 20, if different from Report)		
18. SUPPLEMENTARY NOTES Available in Defense Technical Information Center (DTIC).		
19. KEY WORDS (Continue on reverse side if necessary and identify by block number) cavity flow supersonic flow probe		
20. ABSTRACT (Continue on reverse side if necessary and identify by block number) Flow field investigations of a simulated weapons cavity were performed at Mach 3 in the von Karman Facility Supersonic Tunnel A. Surface pressure measurements, cavity acoustic environment, and flow field pressure and temperature data were obtained on various cavity configurations. Included were studies of suppression fence height and simplified store sizes in an open-sided cavity with length-to-depth ratio of 2.25.		

DD FORM 1473
1 JAN 73

EDITION OF 1 NOV 65 IS OBSOLETE

UNCLASSIFIED

SECURITY CLASSIFICATION OF THIS PAGE (When Data Entered)

CONTENTS

	<u>Page</u>
NOMENCLATURE	2
1.0 INTRODUCTION	5
2.0 APPARATUS	
2.1 Test Facility	5
2.2 Test Article	6
2.3 Test Instrumentation	6
3.0 TEST DESCRIPTION	
3.1 Test Conditions	7
3.2 Test Procedures	7
3.3 Data Reduction	8
3.4 Uncertainty of Measurements	9
4.0 DATA PACKAGE PRESENTATION	9

APPENDIXES

I. ILLUSTRATIONS

Figure

1. Tunnel A	11
2. Cavity Model Details	12
3. Cavity Store Shapes with Pylon	15
4. Probe Holder Details	16
5. Details of Cone Probe	17
6. Installation Sketch	18
7. Installation Photograph	19
8. Artist's Conception of the VKF/CTS Installed in Tunnel A	20
9. Grid Survey Stations	21

II. TABLES

Table

1. Data Transmittal Summary	23
2. Cavity Instrumentation Summary	24
3. CTS Motion Capabilities in Tunnel A	25
4. Estimated Uncertainties	26
5. Test Summary	29

III. SAMPLE TABULATED DATA

Sample

1. Tunnel Conditions and Position Data	31
2. Cavity Surface Pressure Data	32
3. Cavity Acoustic and Probe Parameter Data	33

NOMENCLATURE

A	Cavity acoustic data-type
ALPHAC	Cavity model angle of attack or CTS pitch drive, deg
ALPHAP	Probe angle of attack, deg
CODE	Model configuration number
CONFIG	Model configuration designation
DPP	Pitch plane cone probe differential pressure, PCS1-PCS3, psia
DPY	Yaw plane cone probe differential pressure, PCS2-PCS4, psia
ETAC	CTS aft yaw drive, deg
FE'ICE	Suppression fence height in percent of estimated boundary layer thickness ($\delta = 0.468$ in.)
GRID	A predetermined set of probe positions used to command the CTS motion in computer control
M	Free-stream Mach number
MC	Computed cone probe Mach number
MP	Computed rearward-facing pitot probe Mach number
P	Free-stream static pressure, psia or probe data-type
PCSi	Cone probe static pressures, i=1-4, psia
PCSA	Average cone probe static pressure, psia
PCT	Cone probe total pressure, psia
PHICB	CTS roll drive, deg



Accession For	
NTIS GRA&I	<input checked="" type="checkbox"/>
DTIC TAB	<input type="checkbox"/>
Unannounced	<input type="checkbox"/>
Justification	<input type="checkbox"/>
By _____	
Distribution/	
Availability Codes	
Dist	Avail and/or
A	1

PHIP	Probe roll angle, deg
PN	Data point number
PPT	Rearward-facing probe total pressure, psia
PT2	Stagnation pressure downstream of a normal shock, psia
PT	Tunnel stilling chamber pressure, psia
PW	Cavity static pressure data-type
Q	Free-stream dynamic pressure, psia
RE	Free-stream unit Reynolds number, ft^{-1}
RUN	Data set identification number
STORE	Percent of cavity cross section area occupied by store shape (total area = 36 in. ²)
T	Free-stream static temperature, °R
Txxx	Cavity static pressure tap number
TxxxA	Cavity acoustic pressure tap number
TPT	Total temperature probe temperature, °R
TRIP	Boundary layer trip size, in.
TT	Tunnel stilling chamber temperature, °R
X	Axial drive position, in.
XC	CTS axial drive, in.
XO	Cavity model axial coordinate, positive aft from model leading edge, in.
XPC,XPP,XPT	Axial position of cone, pitot, and temperature probes, respectively, from cavity model leading edge, in.

Y	Lateral drive position, in.
YAWC	Cavity model yaw angle or CTS forward yaw drive, deg
YAWP	Probe yaw angle, deg
YO	Cavity model lateral coordinate, positive right (looking upstream) from model centerline, in.
YPC,YPP,YPT	Lateral position of cone, pitot, and temperature probe, respectively, from cavity model centerline, in.
Z	Vertical drive position, in.
ZC	CTS vertical drive, in.
ZO	Cavity model vertical coordinate, positive up from the top of cavity, in.
ZPC,ZPP,ZPT	Vertical position of cone, pitot, and temperature probes, respectively, from the top of the cavity, in.
δ	Theoretically estimated turbulent boundary layer thickness, in.

1.0 INTRODUCTION

The work reported herein was performed by the Arnold Engineering Development Center (AEDC), Air Force Systems Command (AFSC), under Program Element 61101F, Control Number 0100, at the request of Air Force Weapons Laboratory (AFWL), Kirtland Air Force Base, New Mexico 87117. The AFWL/NTSAC project manager was Mr. J. W. Doran. The results were obtained by Calspan Field Services, Inc./AEDC Division, operating contractor for the Aerospace Flight Dynamics testing effort at the AEDC, AFSC, Arnold Air Force Station, Tennessee. The test was performed in the von Karman Gas Dynamics Facility (VKF) Supersonic Tunnel A on 27 October 1981, under AEDC Project number C146VA.

The test objective was to provide experimental data to support verification of Lockheed General Interpolants Method (GIM) computer code for two-dimensional flow in a simulated weapons cavity.

Testing was accomplished at Mach 3, Reynolds number $3.0 \times 10^6 \text{ ft}^{-1}$ at zero incidence to the free-stream. Vertical flow-field surveys were made forward, aft, and within the cavity utilizing a probe mounted on the VKF Captive Trajectory System (CTS). The instrumented cavity length-to-depth ratio was 2.25. Data were obtained on configurations of varying store sizes (relative to cavity cross section area) and suppression fence height. Photographic data were obtained at all test data points. Expected cavity wave motion was not detectable either acoustically or optically during the test. However, a subsequent review of the high speed schlieren (4000 fps) movies obtained indicates that a typical cavity wave motion was present.

All test data have been transmitted to the sponsor/user as described in Table 1. Inquiries to obtain copies of the test data should be directed to AFWL/NTSAC, Kirtland Air Force Base, NM 87117. A microfilm record of the tabulated data has been retained in the VKF at AEDC.

2.0 APPARATUS

2.1 TEST FACILITY

Tunnel A (Fig. 1) is a continuous, closed-circuit, variable density wind tunnel with an automatically driven flexible-plate-type nozzle and a 40- by 40-in. test section. The tunnel can be operated at Mach numbers from 1.5 to 6 at maximum stagnation pressures from 29 to 200 psia, respectively, and stagnation temperatures up to 750°R at Mach number 6. Minimum operating pressures range from about one-tenth to one-twentieth of the maximum at each Mach number. The tunnel is equipped with a model injection system which allows removal of the model from the test section while the tunnel remains in operation. A description of the tunnel and airflow calibration information may be found in the Test Facilities Handbook*.

*Test Facilities Handbook (Eleventh Edition). "von Karman Gas Dynamics Facility Vol. 3" Arnold Engineering Development Center, June 1979.

2.2 TEST ARTICLE

The test article (Fig. 2) was a simulated weapons cavity of length-to-depth ratio 2.25 cut out from a flat-top wedge designed and fabricated at AEDC. The stainless steel model was instrumented with 40 static pressure orifices and five acoustic microphones (Table 2). The static pressure orifices were arranged in 5 rays to obtain cross flow pressure distribution. The cavity was located 30.0 in. from the flat plate leading edge. The rear wall was situated 9.0 in. downstream of the cavity edge. A boundary layer trip consisting of a CarborundumTM grit (#60, 0.0160 in. height) strip 0.25 in. wide was located 1.5 in. from the leading edge to induce transition of the boundary layer. Model configuration variables included suppression fences and simple store shapes. Interchangeable fences (Fig. 2d) of 0.0, 0.5, and 1.0 boundary layer thickness were provided (boundary layer thickness, δ , was estimated as 0.47 in.). The 0.5 δ fence was not used. Simplified store shapes (Fig. 3) with pylon attachments were built corresponding to 25, 50, and 75 percent of the total cavity cross-section area (36.0 in.²). The 75 percent store was not used. The baseline configuration was the empty cavity without the fence.

Flow field surveys were made using the probes shown in Fig. 4. The probes mounted on the CTS consisted of a 5-hole Mach number/flow angularity 20 deg half-angle cone probe, an unshielded Chromel®-Alumel® total temperature probe, and a 0.093 in. OD rearward facing Mach number pitot probe. Details of the cone probe are provided in Fig. 5.

An installation sketch of the model in Tunnel A is provided in Fig. 6, and an installation photograph is shown in Fig. 7.

2.3 TEST INSTRUMENTATION

The cavity model was instrumented with 40 surface static pressure taps longitudinally spaced in 0.5 in. (or greater) increments on five lateral rays. The lateral rays were required to check for three dimensional flow effects. The primary instrumentation ray was along the model centerline. In addition, five dynamic pressure transducers were located in the cavity model and used to record acoustic environment and average cavity sound pressure level. Model angle of attack was set to zero as indicated by an on-board inclinometer.

The flow field probe (details provided in Section 2.2) was mounted on the VKF Captive Trajectory System (CTS). The CTS* consists of a model support with electro-mechanical drive systems for six degrees of freedom and is attached to the top of the tunnel as shown in the conceptual drawing given in Fig. 8. The axial and vertical motions (XC and ZC) are obtained using linear drive units while lateral motion is achieved by rotating the roll-pitch-yaw support arm about the vertical support axis with the aft yaw mechanism (ETAC) and compensating for the resulting yaw with the forward yaw mechanism (YAWC). The forward yaw

*Billingsley, J. P., Burt, R. H., and Best, J. T. "Store Separation Testing Techniques at the Arnold Engineering Development Center, Volume III: Description and Validation of Captive Trajectory Store Separation Testing in the von Karman Facility." AEDC-TR-79-1, March 1979.

and pitch (ALPHAC) motions are obtained through two knuckle joints with axes 90 deg to each other (the pitch axis is upstream of the yaw axis), and finally the most upstream motion of the system is the roll (PHICB). Only the axial, vertical, and pitch motions were required to achieve the test objectives. The excursion bands and rates of travel of the CTS drives are given in Table 3. The measuring devices, recording devices, calibration methods, and estimated measurement uncertainties of the six degree of freedom motions of the CTS are given in Table 4.

The measuring devices, recording devices, and calibration methods used for all other measured parameters are also listed in Table 4 along with their estimated measurement uncertainties.

Model flow-field photographs were obtained using the VKF Tunnel A double-pass optical flow visualization system. Color schlieren 70mm stills were made using this system at all test data points. High speed (4000 fps) 16 mm color schlieren movies were obtained on each configuration without the influence of the probe. A video cassette recording of the entire test was also made with this system.

3.0 TEST DESCRIPTION

3.1 TEST CONDITIONS

A summary of the nominal test conditions is given below.

<u>M</u>	<u>PT, psia</u>	<u>TT, °R</u>	<u>Q, psia</u>	<u>P, psia</u>	<u>RE x 10⁻⁶/ft</u>
3.0	18.8	530	3.201	0.505	3.0

At some test conditions, particularly at sub-atmospheric stagnation pressures, the air humidity level affects the test section Mach number. The Tunnel A sidewall Mach number probe is used periodically when testing at these conditions to monitor deviations from the standard calibrated Mach numbers. When a deviation is measured, the free-stream conditions are corrected and the actual Mach number is printed on the data tabulations.

A test summary showing all configurations tested and the variables for each is presented in Table 5.

3.2 TEST PROCEDURES

3.2.1 General

For CTS tests in the VKF continuous flow wind tunnels (A, B, C), the parent (cavity) model is mounted on a sting support mechanism in an installation tank directly underneath the tunnel test section. The tank is separated from the tunnel by a pair of fairing doors and a safety door.

When closed, the fairing doors, except for a slot for the pitch sector, cover the opening to the tank and the safety door seals the tunnel from the tank area. After the parent model is prepared for a data run, the personnel access door to the installation tank is closed, the tank is vented to the tunnel flow, the safety and fairing doors are opened, the model is injected into the airstream, and the fairing doors are closed. The parent model was leveled to zero angle of attack and the data obtained. After this, the sequence is reversed and the tank is vented to atmosphere to allow access to the model in preparation for the next data set. The sequence is repeated for each configuration change. Flow field probe attitude and positioning and data recording were accomplished using the CTS in the grid mode of operation. The grid matrices, which are tables of model attitude and position, were loaded into the VKF DEC 10 computer prior to the test. During the test, the required grid was selected and the positioning of the model was controlled by the computer which automatically recorded all the data inputs at each grid point location. Grid survey stations are shown in Fig. 9. Vertical probe surveys were accomplished by driving the CTS in 0.250 in. increments when inside the cavity and in 0.125 in. increments when the probe centerline was at or above $Z_0 = 0.00$ in. Probe centerline was typically 0.250 in. (0.336 in. for 50 percent store) above the model or store surface at the initiation of the survey. All vertical surveys were terminated 1.125 in. above the top of the cavity. The process was repeated until the grid matrix was completed. The data recording for the cavity model was accomplished using the tunnel data acquisition system which was also automatically controlled by the computer.

Initial alignment of the probe and cavity model was achieved through a "touch" docking technique utilizing the CTS electrical grounding circuit. Once the cavity model was leveled the probe was moved to precision wind-off alignment positions. Axial location was checked optically with a scope and the probe driven vertically downward until contact was made with the cavity model, thus completing the ground loop circuit and stopping all drives. The probe was then raised 0.100 in. from the model surface using known linear drive potentiometer settings. Air-on docking positions were recorded such that subsequent dockings were repeated precisely.

3.2.2 Data Acquisition

As described in Section 3.2.1, data were taken in the grid mode of operation using the CTS and tunnel data systems. Data were obtained at predetermined values of probe positions. Dynamic pressure measurements in the cavity (without probe interference) were recorded on analog tape over a time period of 30 sec. Pressure data and probe position data utilized 1 and 10 samples, respectively, taken over a 1 sec time span.

3.3 DATA REDUCTION

Cavity model and probe pressure/temperature data were obtained utilizing the CTS data acquisition system as described in Section 3.2. Cavity surface static pressure data were normalized by free-stream static pressure. Cavity acoustic environment was converted to sound pressure level. Probe parameters were true readings. Cone probe differential pressures were also provided.

Cone-derived Mach number (MC) was evaluated by a technique developed at VKF for this probe and is described in AEDC-TR-80-52*. Rearward facing pitot probe Mach number was evaluated but was nominally zero.

Relative probe positions were given in inches referenced to the centerline point on the cavity model leading edge (Fig. 9).

3.4 UNCERTAINTY OF MEASUREMENTS

In general, instrumentation calibrations and data uncertainty estimates were made using methods recognized by the National Bureau of Standards (NBS)**. Measurement uncertainty is a combination of bias and precision errors defined as:

$$U = \pm (B + t_{95}S)$$

where B is the bias limit, S is the sample standard deviation, and t_{95} is the 95th percentile point for the two-tailed Student's "t" distribution (95-percent confidence interval), which for sample sizes greater than 30 is taken equal to 2.

Estimates of the data uncertainties in the basic measurements of this test are given in Table 4a. Data uncertainties are determined from in-place calibrations through the data recording system and data reduction program.

Propagation of the bias and precision errors of measured data through the calculated data are made in accordance with the reference** below and the results are given in Table 4b.

4.0 DATA PACKAGE PRESENTATION

The data package contains tabulated cavity model and probe pressure data along with tunnel condition and position data. Sample tabulations are given in Appendix III.

* Gray, J. D. and Billingsley, J. P. "Internal Drag Experiments for Data Correlation, ASALM PTV/TVV," AEDC-TR-80-52, May 1981.

** Thompson, J. W. and Abernethy, R. B. et al., "Handbook Uncertainty in Gas Turbine Measurements." AEDC-TR-73-5 (AD755356), February 1973.

APPENDIX I

ILLUSTRATIONS

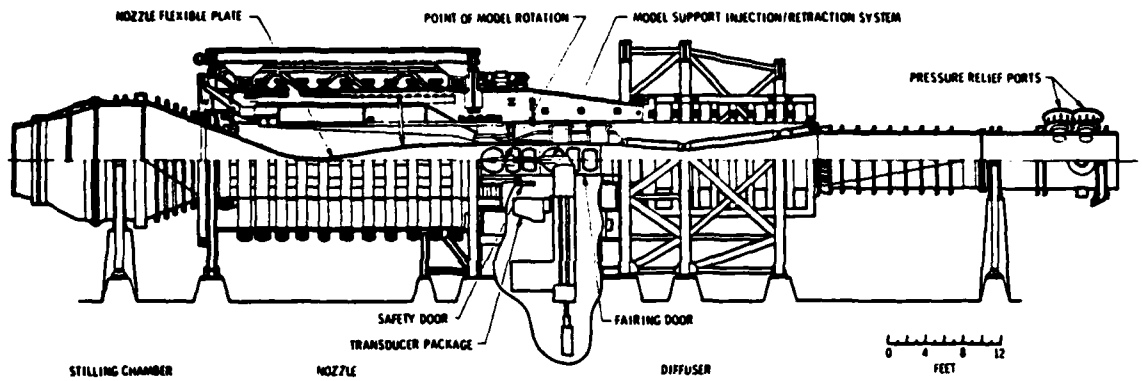

a. Tunnel assembly

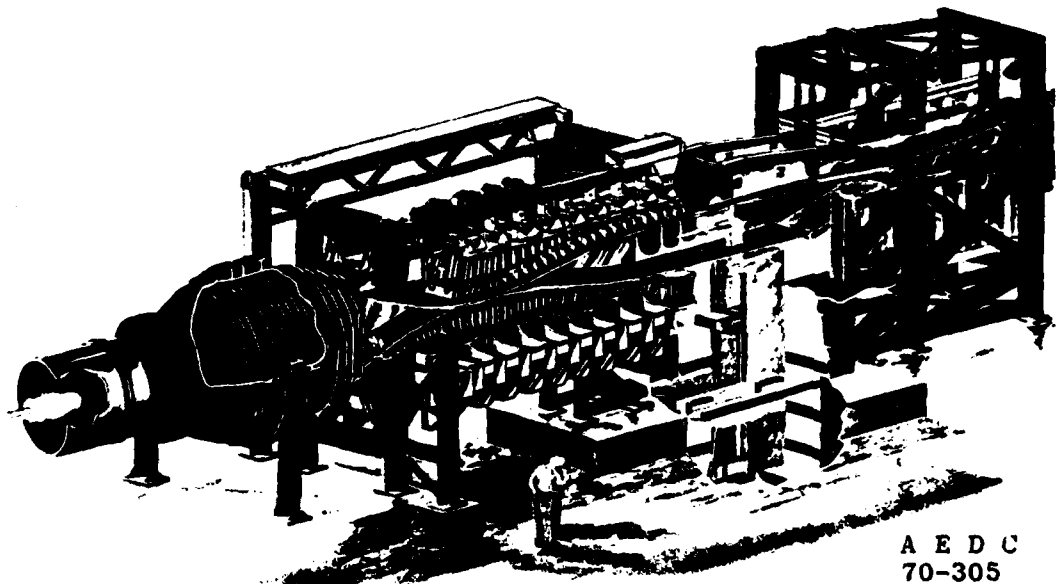

b. Tunnel test section
Fig. 1 Tunnel A

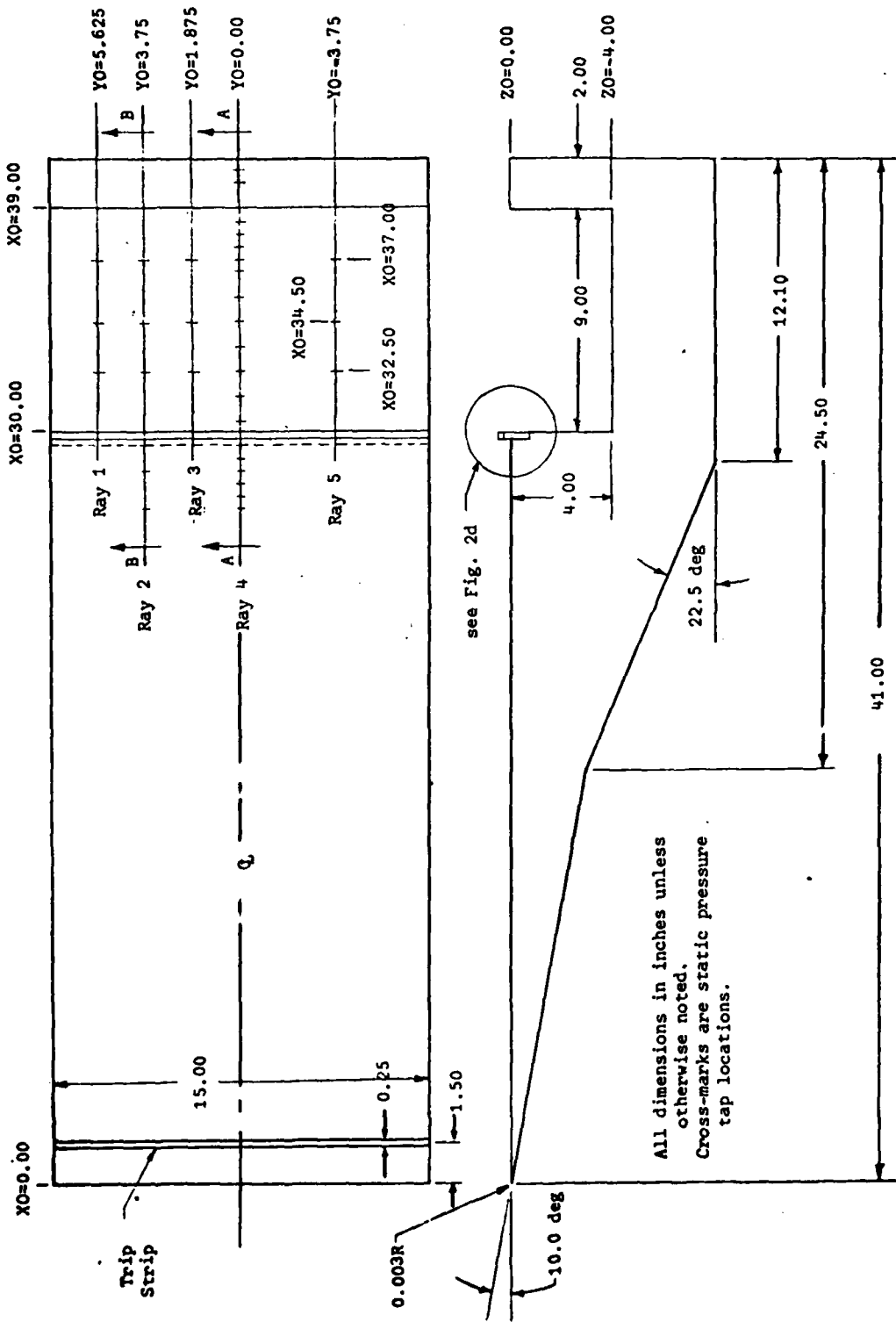

a. Cavity
 Figure 2. Cavity Model Details

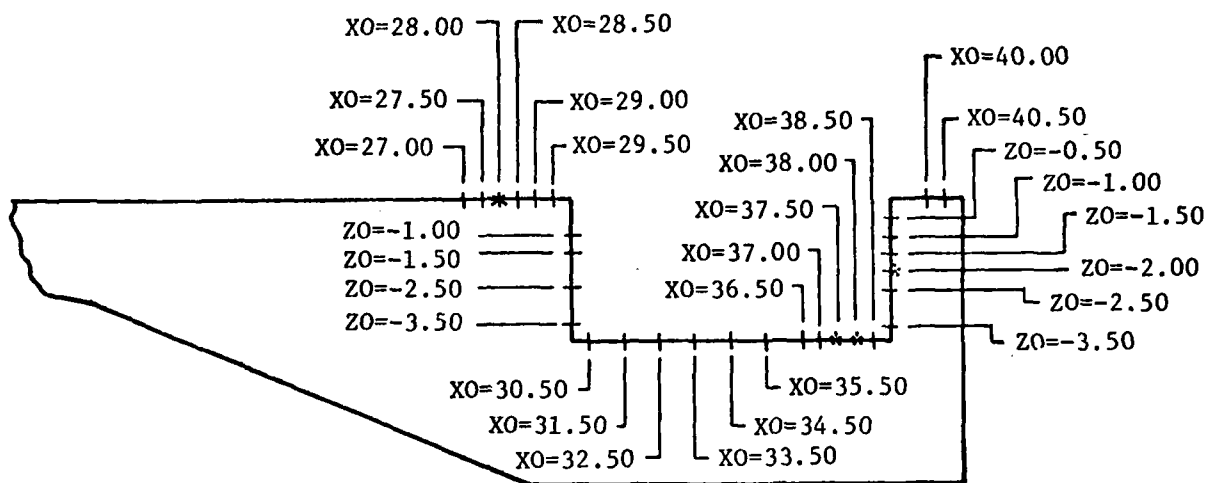

View A-A

b. Ray 4 Detail (YO=0.00)

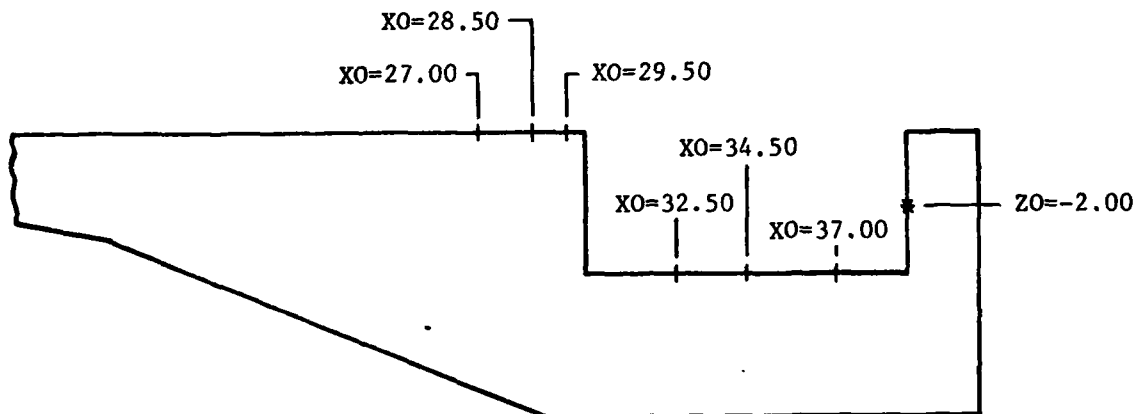

View B-B

c. Ray 2 Detail (YO=3.75)

Cross-marks are static pressure tap locations.
 "*" denotes dynamic pressure transducer.
 Rays 1, 3, 5 detail given on Fig. 2a.

Figure 2. Continued

Fences extend full span of cavity (15.00in.).
 δ = Estimated turbulent boundary layer height.

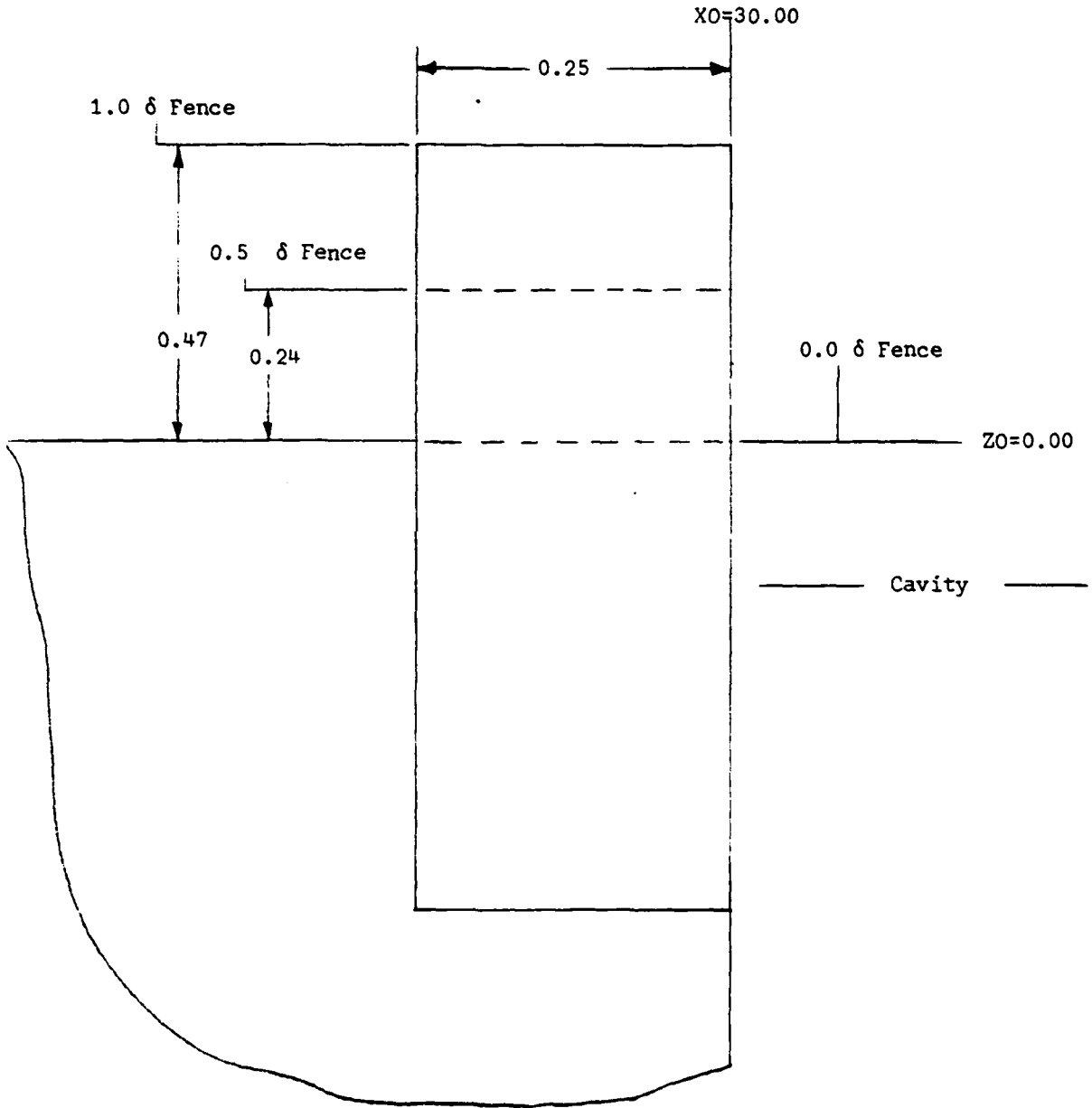
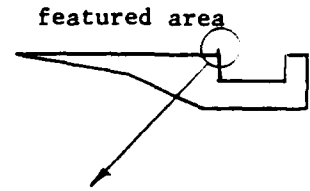

d. Enlarged View of Suppression Fence

Figure 2. Concluded

All dimensions in inches unless otherwise noted.
 Store sizes relative to 36in.² cavity cross-section area.
 Store shapes are full span of cavity (15.00 in.).

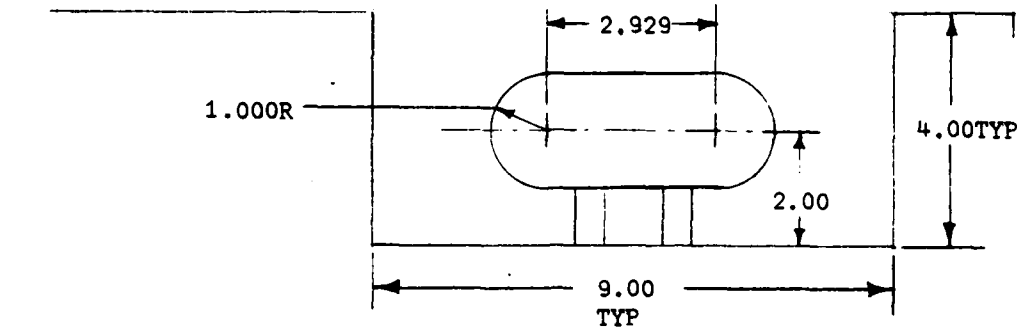

a. 25% Store

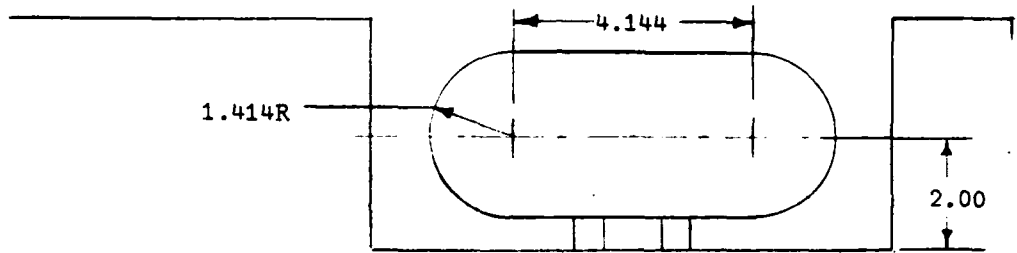

b. 50% Store

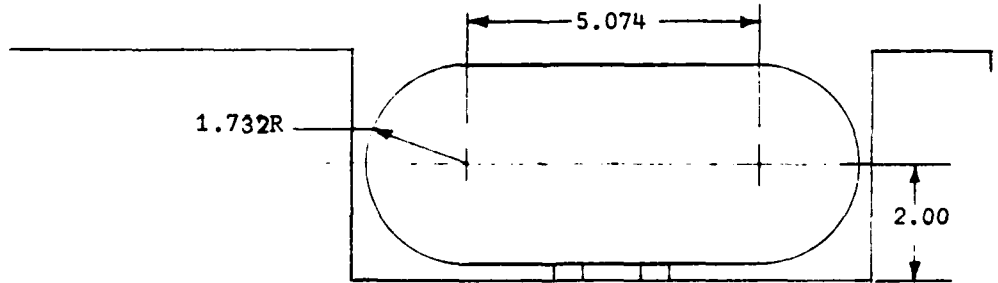

c. 75% Store

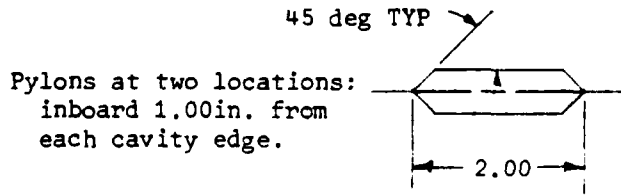

d. Store Pylon

Figure 3. Cavity Store Shapes with Pylon

All dimensions in inches unless otherwise noted.

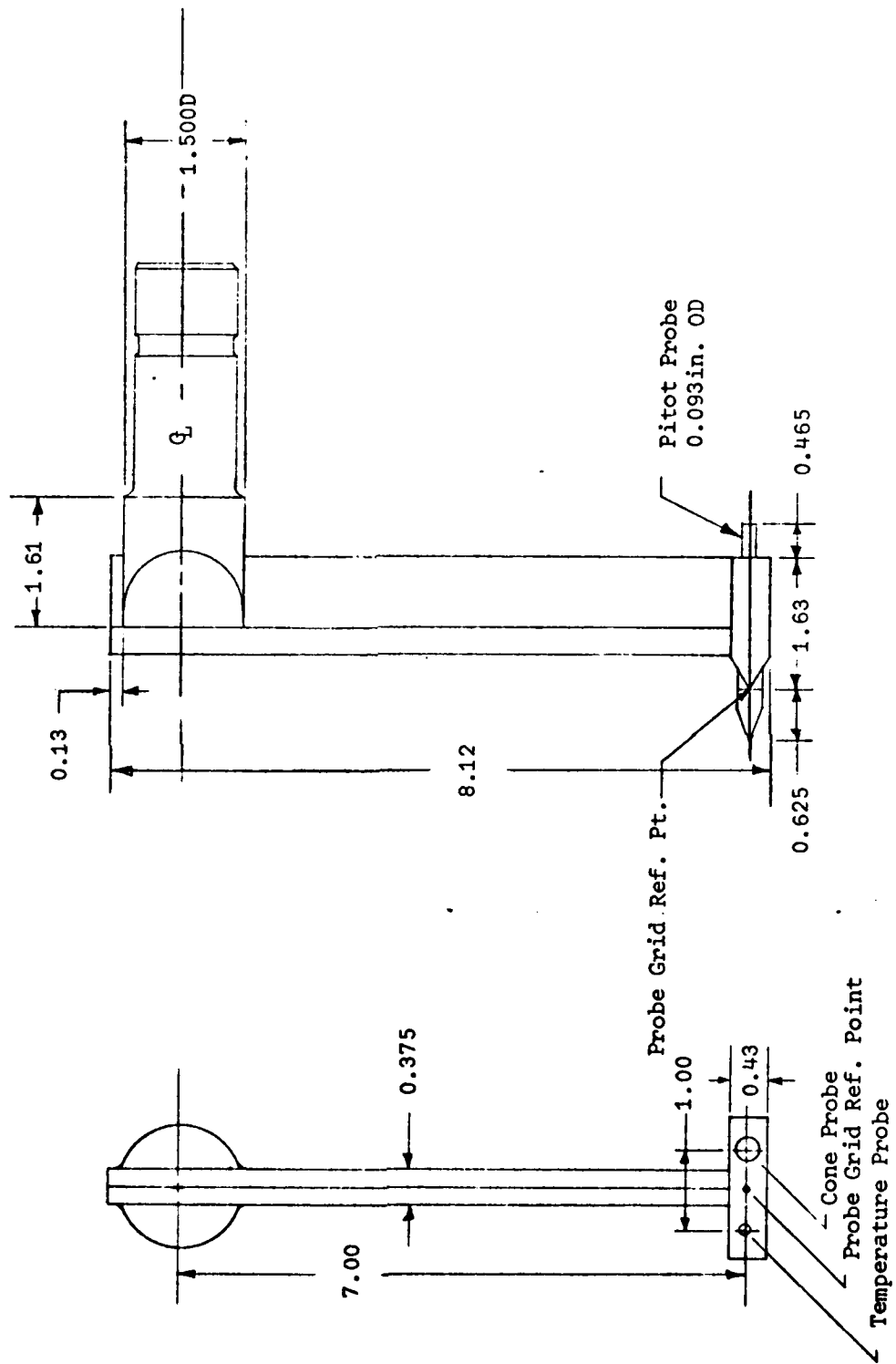
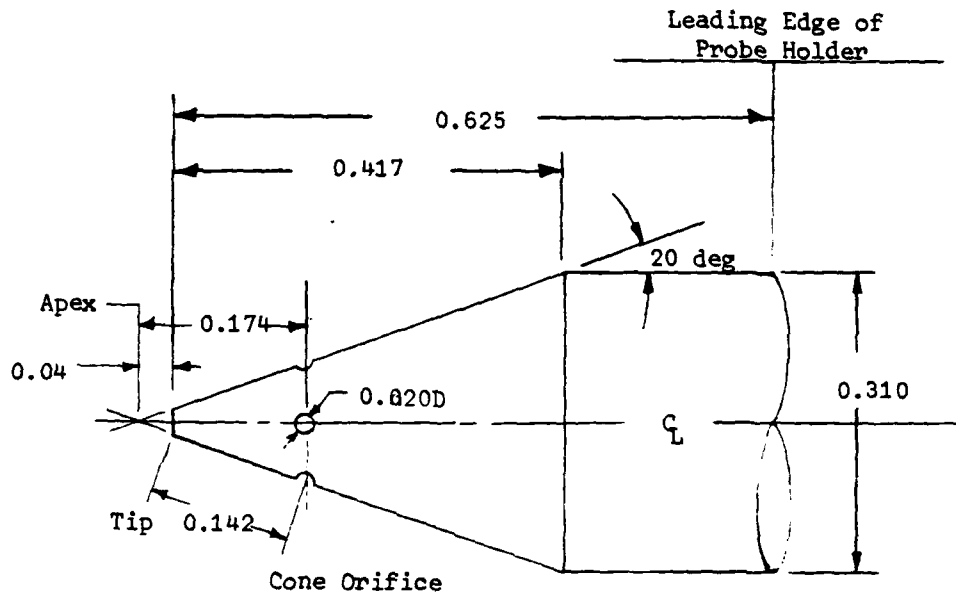

Figure 4. Probe Holder Details



All dimensions in inches unless otherwise noted.

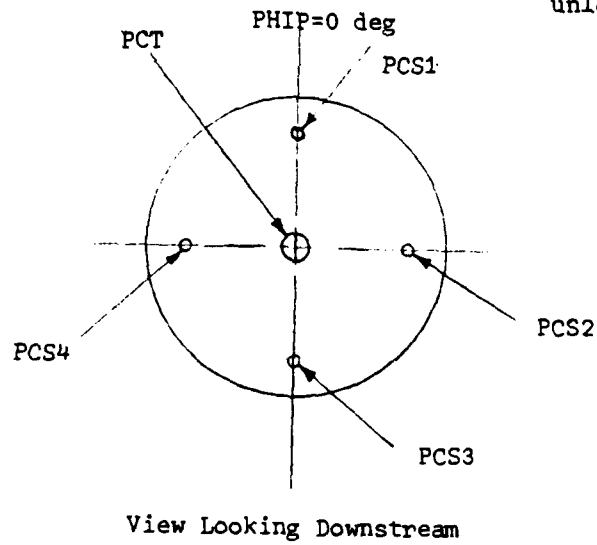

Figure 5. Details of Cone Probe

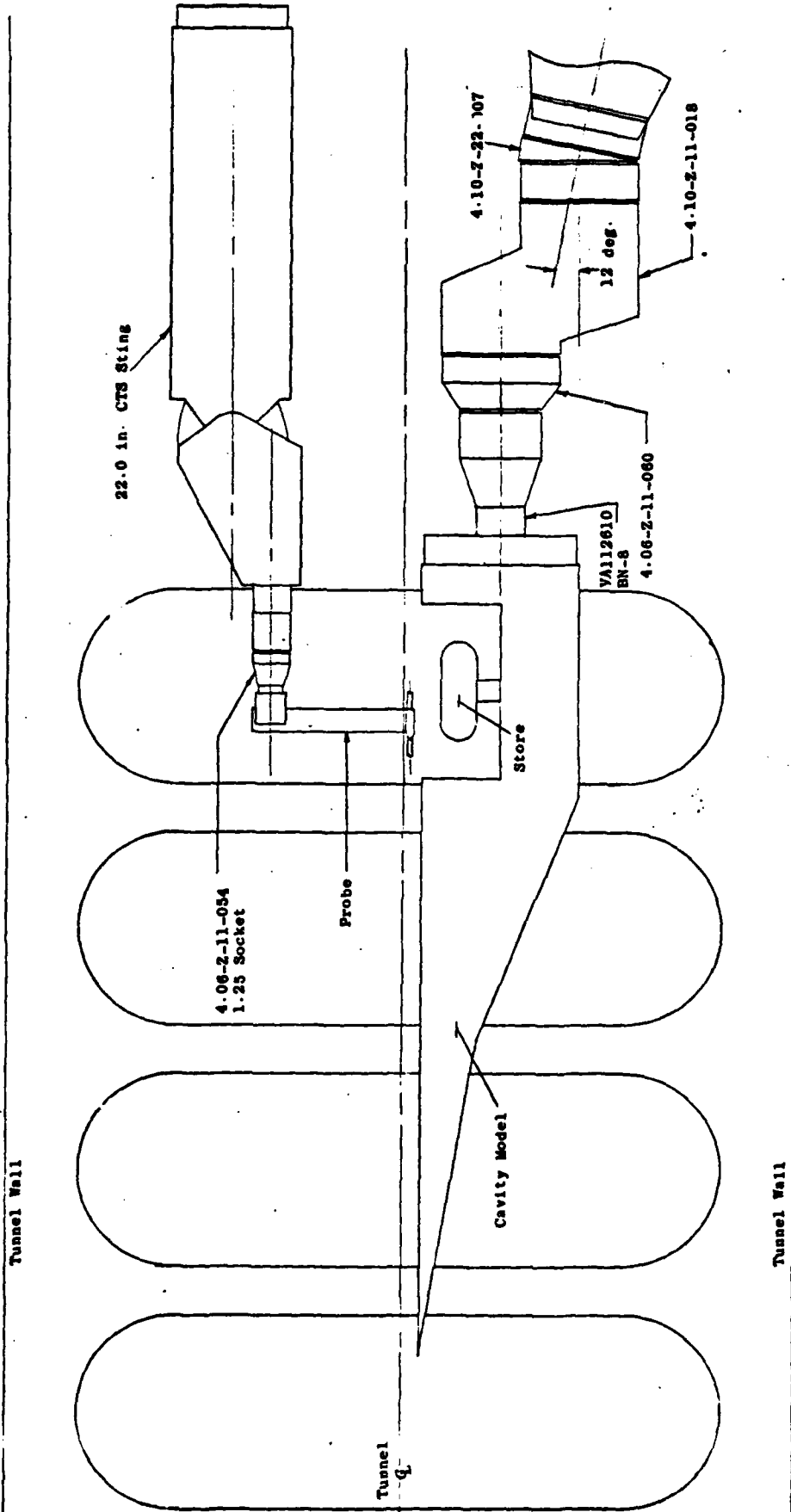

Figure 6. Installation Sketch



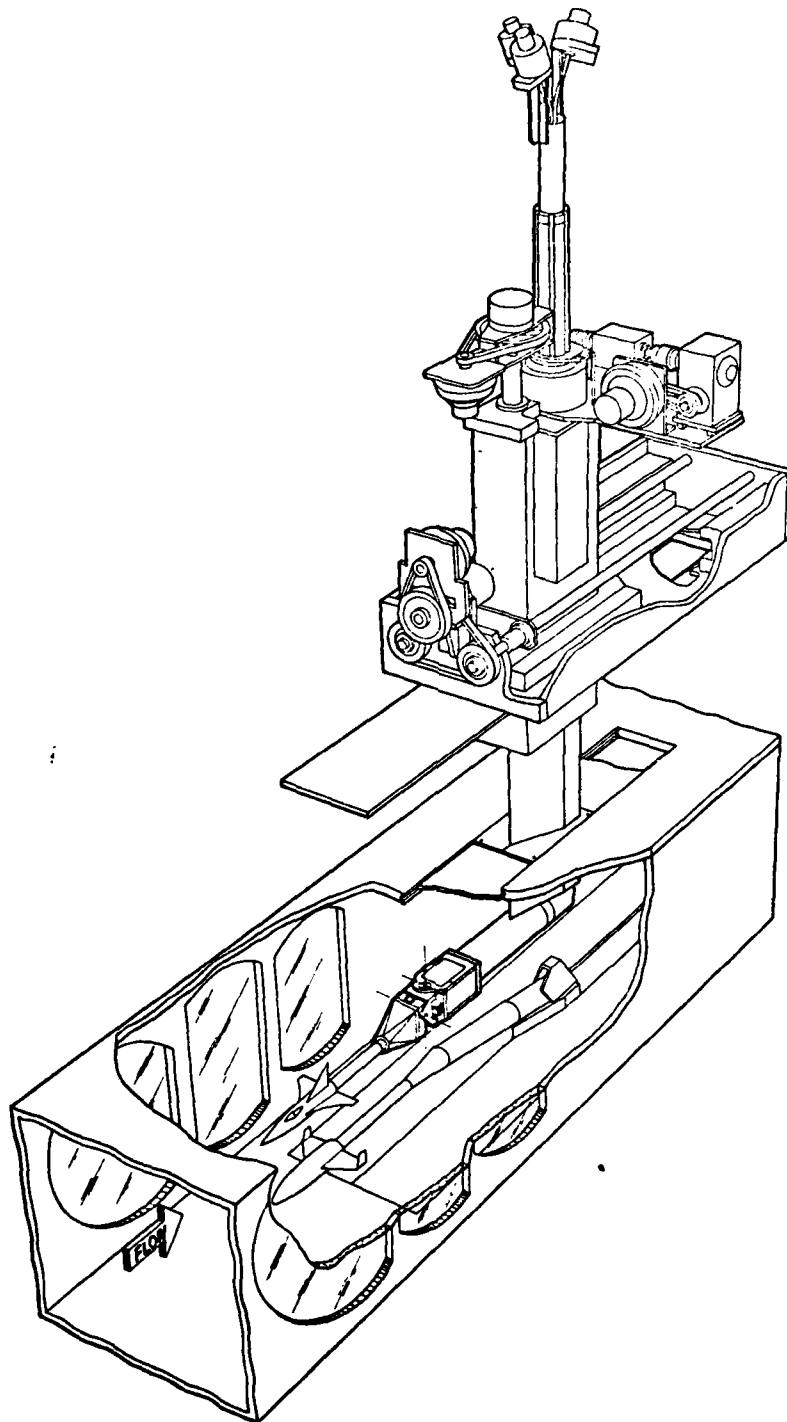
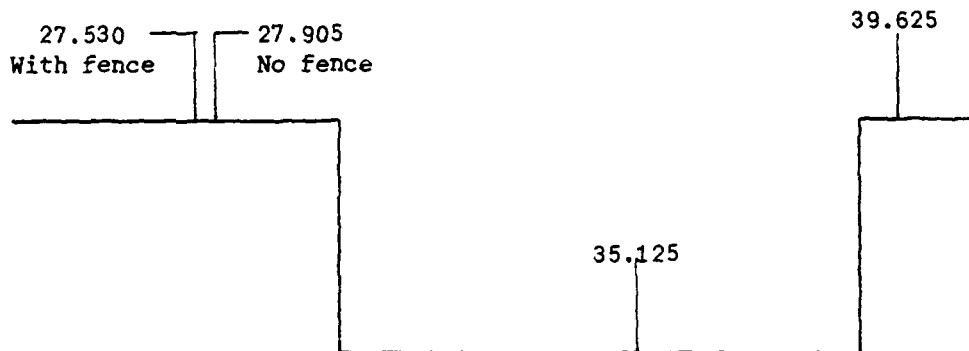

Figure 8. Artist's Conception of the VKF/CTS
Installed in Tunnel A



Actual probe tip locations are given by the following since orientations (ALPHAP, YAWP, PHIP) are zero or negligible.

<u>Cone Probe</u>	<u>Pitot Probe</u>	<u>Temperature Probe</u>
XPC = X-0.625	XPP = X+2.095	XPT = X-0.625
YPC = Y-0.500	YPP = Y-0.500	YPT = Y+0.500
ZPC = Z	ZPP = Z	ZPT = Z

All survey stations have probe grid reference point on model centerline, $Y_0 = 0.00$. Axial locations are for probe grid reference point from leading edge of flat plate, $X_0 = 0.00$. Probe grid reference point shown in Figure 4.

Figure 9. Grid Survey Stations

APPENDIX II

TABLES

TABLE 1. Data Transmittal Summary

The following items were transmitted to the Sponsor/User.

<u>Item</u>	<u>Sponsor/User</u>	<u>No. of Copies</u>
	Mr. J. W. Doran AFWL/NTSAC Kirtland AFB, NM 87117	
Final Tabulated Data, Runs 1-20*,+		2 (Others: 1 copy)
Data Transit Tape+		1
Sample Tape Printout+		1
Data Transit Tape Format+		1
70mm Schlieren Stills* Roll No. 0052		1 Contact Print 1 Duplicate Negative
16mm Schlieren Movies: Reel Nos. 4548-4553		1 Optical Master 1 Work Print*
Photographic Data Log		1
Video Cassette, Runs 1-20		1
Model Installation Photographs, 8x10 prints*,+		2 (Others: 1 copy)

Other Data Distribution:

* Mr. L. L. Shaw
AFWAL/FIBE
Wright Patterson AFB, OH 45433

+ Mr. Alan Ratliff
LMSC
4800 Bradford Blvd.
Huntsville, AL 35807

TABLE 2. Cavity Instrumentation Summary

T _{xxx}	X ₀	Y ₀	Z ₀
101	32.50	5.625	-4.00
102	34.50	↓	↓
103	37.00	↓	↓
201	27.00	3.75	0.00
202	38.50	↓	↓
203	29.50	↓	↓
204	32.50	↓	-4.00
205	34.50	↓	↓
206	37.00	↓	↓
207A	39.00	↓	-2.00
301	32.50	1.875	-4.00
302	34.50	↓	↓
303	37.00	↓	↓
401	27.00	0.00	0.00
402	27.50	↓	↓
403A	28.00	↓	↓
404	28.50	↓	↓
405	29.00	↓	↓
406	29.50	↓	↓
407	30.00	↓	-1.00
408	↓	↓	-1.50
409	↓	↓	-2.50
410	↓	↓	-3.50

T _{xxx}	X ₀	Y ₀	Z ₀
411	30.50	0.00	-4.00
412	31.50	↓	↓
413	32.50	↓	↓
414	33.50	↓	↓
415	34.50	↓	↓
416	35.50	↓	↓
417	36.50	↓	↓
418	37.00	↓	↓
419A	37.50	↓	↓
420A	38.00	↓	↓
421	38.50	↓	↓
422	39.00	↓	-3.50
423	↓	↓	-2.50
424A	↓	↓	-2.00
425	↓	↓	-1.50
426	↓	↓	-1.00
427	↓	↓	-0.50
429	40.00	↓	0.00
430	40.50	↓	0.00
501	32.50	-3.75	-4.00
502	34.50	↓	↓
503	37.00	↓	↓

TABLE 3. CTS Motion Capabilities in Tunnel A

<u>MOTION</u>	<u>MAXIMUM¹ TRAVEL LIMITS</u>	<u>MAXIMUM² RATE OF TRAVEL</u>
XC	±20 in.	1.2 in.-sec ⁻¹
ZC	±15 in.	1.2 in. - sec ⁻¹
ETAC ³	±25 deg	2.7 deg-sec ⁻¹
YAWC ³	±45 deg	10.4 deg-sec ⁻¹
ALPHAC	±45 deg	11.7 deg-sec ⁻¹
PHICB	±180 deg	20.5 deg-sec ⁻¹

- NOTES:
1. Travel limits are set up for each test as a function of model location in the tunnel and the test requirements.
 2. Rates are continuously variable up to the values shown and can be computer controlled to allow all drives to reach a commanded point simultaneously.
 3. YAWC and ETAC combine to provide a lateral motion of ±15 in.

CTS Motion Nomenclature

ALPHAC	CTS pitch drive, deg
ETAC	CTS aft yaw drive, deg
PHICB	CTS roll drive, deg
XC	CTS axial drive, in.
YAWC	CTS forward yaw drive, deg
ZC	CTS vertical drive, in.

TABLE 4. ESTIMATED UNCERTAINTIES
a. Basic Measurements

Parameter Designation	STEADY-STATE ESTIMATED MEASUREMENT*						Type of Measuring Device	Type of Recording Device	Method of System Calibration	
	Precision Index $\pm (S)$		Bias $\pm (B)$		Uncertainty $\pm (B + 1.95S)$					Range
	Percent of Reading	Unit of Measurement	Degree of Freedom	Percent of Reading	Unit of Measurement	Unit of Measurement				
PT, psia	0.007	30	0.2	0.0021	0.2	0.014	15-60	Bell and Howell Force Balance Pressure Transducer	Analog to Digital (A-D) Converter into Digital Data Acquisition System (DEAS)	In-flow application of multipoint calibration levels using a pressure device (DEAS)
TT, °F	1.0	30		0.0021	2.0	4.0	70-300	Chromel [®] -Alumel [®] Thermocouple	Digital scanner via microprocessor based DEAS computer multiplexer via Fluke Instrumentation digital thermometer	Fluke calibration levels using a pressure device (DEAS)
CTS Drives										
XC, in.	0.0040	30		0.0021		0.0101	±20	Potentiometer	Digital scanner via A/D converter	Fluke calibration levels using a pressure device (DEAS)
ZC, in.	0.0056	30		0.0004		0.0116	±15			
PH(CB, deg)	0.0877	30		0 ⁺		0.1754	N/A			
ALPPAC, deg	0.0295	30		0.0102		0.0632	±45			
VAC, deg	0.0204	30		0 ⁺		0.0408	N/A			
LEAC, deg	0.0148	30		0 ⁺		0.0296	N/A			
ALPPAC, deg (cavity)	0.005	30		0.05		0.06	±4	Shaeffler Servo inclinometer		Fluke calibration levels using a pressure device (DEAS)
VAC, deg (cavity)	0.25	30		0 ⁺		0.30	±0.5	Precision inclinometer gage reading	Manual	Fluke calibration levels using a pressure device (DEAS)
Txxx, psia	0.0015	30	0.15			0.15Txxx + 0.0030	0-15	Bell and Howell differential capacitance pressure transducer	A/D Converter into DEAS	Fluke calibration levels using a pressure device (DEAS)
PCSI-PCS4, PCT, PPT, psia	0.003	30		0.005		0.011	0-15	Kistler Force Balance Pressure Transducer		Fluke calibration levels using a pressure device (DEAS)
TPT, °F	1.0	30		2.0		4.0	70-300	Chromel [®] -Alumel [®] Thermocouple	Fluke digital thermometer into Fluke Scanner into DEAS	Fluke calibration levels using a pressure device (DEAS)
TxxxA, dB	0.5	30		0 ⁺		1.0	105-180	Gulton microphone	R/S voltmeter into A/D converter into DEAS	Fluke calibration levels using a pressure device (DEAS)

*Thompson, J. W. and Abernethy, R. B. et al. "Handbook Uncertainty in Gas Turbine Measurements," AHDC-TR-73-5 (AD 750556), February 1973.

Assumed to be zero

TABLE 4. Continued
a. Concluded

Parameter Designation	STEADY-STATE ESTIMATED MEASUREMENT*						Range	Type of Measuring Device	Type of Recording Device	Method of Standard Calibration	
	Precision Index (S)		Bias (B)		Uncertainty $\pm(B + 1.96S)$						
	Percent of Reading	Unit of Measurement	Degree of Freedom	Percent of Reading	Unit of Measurement	Percent of Reading	Unit of Measurement				
DYNAMIC PRESSURE MEASUREMENT, dB	0.5		30	0 ⁺		1.0		105-180	Gulton microphone	Bell & Howell VR-3700 Analok magnetic tape machine	BBN & KESL PISTON PRESSURE LAB

*Thompson, J. W. and Abernethy, R. B. et al. "Handbook Uncertainty in Gas Turbine Measurements." AEDC-TR-73-5 (AD 735356), February 1973.

TABLE 4. Concluded
b. Calculated Parameters

Parameter Designation	Precision Index (\$)				Bias (B)				Uncertainty $\pm(B + 1.95S)$				
	Percent of Reading	Unit of Measure	Degree of Freedom	Percent of Reading	Unit of Measure	Percent of Reading	Unit of Measure	Percent of Reading	Unit of Measure	Percent of Reading	Unit of Measure	Percent of Reading	Unit of Measure
M		0.005			0 ⁺			0.016				0.016	
P, psia		0.0060			0.0010			0.0100				0.0100	
Q, psia		0.0214			0.0064			0.0492				0.0492	
PT2, psia		0.0422			0.0122			0.0966				0.0966	
REX10-6, ft ⁻¹		0.0655			0.1287			0.2597				0.2597	
X, XPC, XPP, XPT		0.010			0.004			0.024				0.024	
Y, YPC, YPP, YPT		0.018			0 ⁺			0.036				0.036	
Z, ZPC, ZPP, ZPT		0.015			0.004			0.034				0.034	
ALPHAP		0.046			0.010			0.102				0.102	
YAWP		0.025			0 ⁺			0.050				0.050	
PHIP		0.088			0 ⁺			0.176				0.176	

Abernethy, R. B. et al. and Thompson, J. W. "Handbook Uncertainty in Gas Turbine Measurements," AEDC-TR-73-5 (AD 755356), February 1973.

Assumed to be Zero

Revised (AEDC-TR-73-5) 9-79

TABLE 5. Test Summary

M = 3, RE = $3.0 \times 10^6 \text{ft}^{-1}$, ALPHA = 0.0 deg

Configuration: Cavity Flow Model (No Probe)

STORE ¹	FENCE ²	RUN
0	0	12
0	1	11
25	0	1,20
25	1	6
50	1	16
-	-	5 ³

Configuration: Cavity Flow Model (With Probe)

STORE ¹	FENCE ²	SURVEY STATION ⁴		
		FWD	MID	AFT
0	0	15	14	13
25	0	4	3	2
25	1	9,10	8	7
50	1	19	18	17

NOTES:

1. STORE - Percent of cavity cross-section area occupied by store shape. Total area = 36.0 in.²
2. FENCE - Suppression fence height normalized by estimated boundary layer thickness. $\delta = 0.47$ in.
3. RUN 5 - Probe calibration in free-stream. ALPHAP = -5.0 to 5.0 deg
4. SURVEY STATION - Location of probe grid survey in inches from model leading edge.
 FWD - 27.905 in. (no fence); 27.530 in. (with fence)
 MID - 35.125 in.
 AFT - 39.625 in.

APPENDIX III

SAMPLE TABULATED DATA

DATE COMPUTED 9-NOV-81
 TIME COMPUTED 14:32:20
 DATE RECORDED 27-OCT-81
 TIME RECORDED 5:40:30
 PROJECT NUMBER V A-22

VON KARNAN GAS DYNAMICS FACILITY
 ARMOLO AIR FORCE STATION, TENNESSEE
 AFWL CAVITY FLOW

PAGES 1 CHID 1- 1

RUN CODE M PT TT Q P PT2 T RE
 13 6 3.01 18.76 539.7 3.191 0.503 6.107 191.9 0.291E+07
 CONFIG STORE STROKE TRIP DATA TYPE
 CAVITY FLOW MODEL 0 0.0 .0160 P+PW+A

CAVITY MODEL
 -ATTITUDE:-
 * - TUNNEL CONDITIONS *
 * - PRORES *
 * - POSITIONS -

PR	ALPHAC	YAVC	PT	TI	Q	P	PT2	X	Y	Z	ALPHAP	YAMP	PHIP
1	0.01	0.00	18.76	539.7	3.191	0.503	6.1066	39.6234	-0.0096	0.2535	-0.0185	-0.0256	-0.0118
2	0.01	0.00	18.75	539.7	3.189	0.503	6.1042	39.6234	-0.0091	0.3791	-0.0200	-0.0241	-0.0118
3	0.01	0.00	18.75	539.7	3.189	0.503	6.1030	39.6235	-0.0096	0.5015	-0.0189	-0.0256	-0.0118
4	0.01	0.00	18.75	539.7	3.189	0.503	6.1042	39.6234	-0.0101	0.6285	-0.0200	-0.0270	-0.0170
5	0.01	0.00	18.76	539.7	3.191	0.503	6.1078	39.6232	-0.0091	0.7537	-0.0200	-0.0241	-0.0118
6	0.01	0.00	18.75	539.7	3.189	0.503	6.1042	39.6234	-0.0091	0.8768	-0.0196	-0.0241	-0.0118
7	0.01	0.00	18.76	539.7	3.191	0.503	6.1066	39.6234	-0.0100	1.0025	-0.0196	-0.0267	-0.0118
8	0.01	0.00	18.77	539.7	3.192	0.503	6.1089	39.6234	-0.0106	1.1265	-0.0189	-0.0285	-0.0118

DATE COMPUTED 9-NOV-81
 TIME COMPUTED 14:32:20
 DATE RECORDED 27-OCT-81
 TIME RECORDED 5:40:30
 PROJECT NUMBER V A-22

VON KARMAN GAS DYNAMICS FACILITY
 ARNOLD AIR FORCE STATION, TENNESSEE
 AFWL CAVITY FLOW

PAGE 3 GPID 1-1

RUN CODE M PT TT O P PT2 T RE
 13 6 3.01 18.76 539.7 3.191 0.503 6.107 191.9 0.291E+07

CONFIG STORE FENCE TRIP DATA TYPE
 CAVITY FLOW MODEL 0 0.0 .0160 P-PM-A

• • CAVITY MODEL ACOUSTIC GAUGES • •
 (SHUND PRESRIUPE LEVEL, DR)

PH	T207A	T403A	T419A	T420A	T424A
1	150.76	120.22	145.73	131.22	144.65
2	150.40	120.38	145.78	131.26	144.75
3	150.80	120.22	145.73	131.26	144.70
4	150.85	120.38	145.78	131.22	144.60
5	150.78	120.38	145.73	131.22	144.65
6	150.67	120.22	145.63	131.22	144.60
7	150.74	120.22	145.73	131.26	144.79
8	150.76	120.38	145.78	131.26	144.70

• • CUNE

ZPC	XPC	YPC	ZPP	XPP	YPP	ZPT	XPT	YPT
0.254	41.718	-0.510	0.254	41.718	-0.510	0.254	38.998	0.490
0.379	41.718	-0.509	0.379	41.718	-0.509	0.379	38.998	0.491
0.505	41.719	-0.510	0.505	41.719	-0.510	0.505	38.999	0.490
0.629	41.718	-0.510	0.629	41.718	-0.510	0.629	38.998	0.490
0.754	41.718	-0.509	0.754	41.718	-0.509	0.754	38.998	0.491
0.877	41.718	-0.509	0.877	41.718	-0.509	0.877	38.998	0.491
1.003	41.718	-0.510	1.003	41.718	-0.510	1.003	38.998	0.490
1.127	41.718	-0.511	1.127	41.718	-0.511	1.127	38.998	0.489

• • RELATIVE PROBE POSITIONS • •
 PITOT

TEMPERATURE

MP	PPT/PT2	PPT	TPT	TPT/TT
0.000	0.042	0.254	502.7	0.978
0.000	0.039	0.239	509.7	0.978
0.000	0.034	0.206	517.7	0.978
0.000	0.028	0.179	523.7	0.978
0.000	0.028	0.174	524.7	0.978
0.000	0.028	0.169	521.7	0.978
0.000	0.026	0.159	519.7	0.978
0.000	0.024	0.148	518.7	0.978

• • PROF. PARAMETERS • •

PH	PCS1	PCS2	PCS3	PCS4	PCSA	PCT	PCS/PCT	PCT/PT2	MC	DPP/PCT	DPY/PCT	PPT	PPT/PT2	MP	TPT	TPT/TT
1	0.764	0.717	0.662	0.788	0.733	1.252	0.585	0.205	1.273	0.082	-0.057	0.254	0.042	0.000	502.7	0.978
2	0.824	0.774	0.711	0.843	0.788	1.906	0.413	0.312	1.692	0.059	-0.036	0.239	0.039	0.000	509.7	0.978
3	0.929	0.877	0.825	0.944	0.894	2.797	0.370	0.458	2.142	0.037	-0.024	0.206	0.034	0.000	517.7	0.978
4	1.073	1.024	0.997	1.096	1.048	4.016	0.261	0.658	2.611	0.019	-0.018	0.179	0.028	0.000	523.7	0.978
5	1.191	1.170	1.184	1.244	1.197	5.182	0.231	0.848	2.981	0.001	-0.014	0.174	0.028	0.000	524.7	0.978
6	1.266	1.285	1.355	1.361	1.317	5.816	0.226	0.953	3.052	-0.015	-0.013	0.169	0.028	0.000	521.7	0.978
7	1.249	1.346	1.462	1.426	1.383	6.064	0.228	0.993	3.024	-0.027	-0.013	0.159	0.026	0.000	519.7	0.978
8	1.316	1.384	1.528	1.465	1.423	6.197	0.230	1.014	3.000	-0.034	-0.013	0.148	0.024	0.000	518.7	0.978

Sample 3: Cavity Acoustic and Probe Parameter Data