



2.8 2.5



METRIC BY RESOLUTION TEST CHART
1963-A

14

DOT/FAA/CT-82/11
MTR-81T7

Terminal Air Traffic Control With Surveillance Data From The Mode S System - Results Of System Demonstrations To Field Controllers

Verne Tallio
Haim Gabrieli (Mitre Corp.)

February 1982

Final Report

This document is available to the U.S. public
through the National Technical Information
Service, Springfield, Virginia 22161.

DTIC
ELECTE
MAR 30 1982
S B



US Department of Transportation
Federal Aviation Administration
Technical Center
Atlantic City Airport, N.J. 08405

AD A112632

DTIC FILE COPY

00 00 00 011

NOTICE

This document is disseminated under the sponsorship of the Department of Transportation in the interest of information exchange. The United States Government assumes no liability for the contents or use thereof.

The United States Government does not endorse products or manufacturers. Trade or manufacturer's names appear herein solely because they are considered essential to the object of this report.

1. Report No.		2. Government Accession No. AD-A112 632		3. Recipient's Catalog No.	
4. Title and Subtitle TERMINAL AIR TRAFFIC CONTROL WITH SURVEILLANCE DATA FROM THE MODE S SYSTEM - RESULTS OF SYSTEM DEMONSTRATIONS TO FIELD CONTROLLERS				5. Report Date February 1982	
7. Author(s) H. GABRIELI (MITRE), V. TALLIO (FAA)				6. Performing Organization Code	
9. Performing Organization Name and Address The MITRE Corporation FAA Technical Center Atlantic City Airport, NJ 08405				8. Performing Organization Report No. MTR-81T7	
12. Sponsoring Agency Name and Address				10. Work Unit No. TRAIS	
				11. Contract or Grant No. DTFA01-81-C-10001	
				13. Type of Report and Period Covered System Demonstration Report - May 1981	
				14. Sponsoring Agency Code ARD-100 and ARD-200	
15. Supplementary Notes					
16. Abstract <p>This report describes the results of a series of system demonstrations of a modified version of the ARTS III system (ADS2) which was developed to operate with target reports provided by the Mode S system. The demonstrations were conducted at the FAA Technical Center with field controllers from the Philadelphia ARTS III facility. The report contains a compilation of the controllers' opinions and comments on the operational characteristics of the new system. This demonstration cannot be considered a comprehensive test and evaluation effort; however, with regard to those system capabilities which were demonstrated, the controllers found no major technical or operational obstacles which would impact the system implementation in an operational environment.</p>					
17. Key Words Mode S, ARTS III, ADS2, Surveillance, Air Traffic Control			18. Distribution Statement Document is available to the U.S. Public through the National Technical Information Service, Springfield, Virginia 22161		
19. Security Classif. (of this report) Unclassified		20. Security Classif. (of this page) Unclassified		21. No. of Pages 68	22. Price

METRIC CONVERSION FACTORS

Approximate Conversions to Metric Measures		Approximate Conversions from Metric Measures	
When You Know	Multiply by	When You Know	Multiply by
Symbol	Symbol	Symbol	Symbol
LENGTH			
inches	2.5	millimeters	0.04
feet	30	centimeters	0.4
yards	0.9	meters	3.3
miles	1.6	kilometers	1.1
AREA			
square inches	6.5	square centimeters	0.16
square feet	0.09	square meters	1.2
square yards	0.8	square kilometers	0.4
square miles	2.6	hectares (10,000 m ²)	2.5
acres	0.4		
MASS (weight)			
ounces	28	grams	0.035
pounds	0.45	kilograms	2.2
short tons (2000 lb)	0.9	tonnes (1000 kg)	1.1
VOLUME			
teaspoons	5	milliliters	0.03
tablespoons	15	liters	2.1
fluid ounces	30	quarts	1.06
cups	0.24	liters	0.26
pints	0.47	gallons	35
quarts	0.95	cubic meters	1.3
gallons	3.8		
cubic feet	0.03		
cubic yards	0.76		
TEMPERATURE (exact)			
Fahrenheit temperature	5/9 later subtracting 32)	Celsius temperature	9/5 (then add 32)

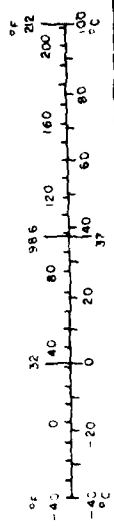
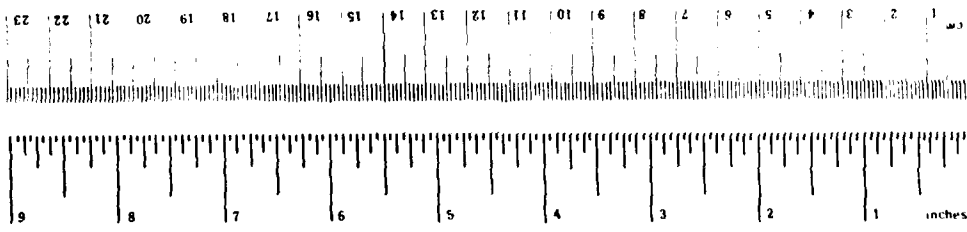

TABLE OF CONTENTS

	<u>Page</u>
INTRODUCTION	1
Purpose	1
Background	1
Scope	2
Report Structure	2
DESCRIPTION OF THE DEMONSTRATION MISSIONS	3
Demonstration Configurations	3
Video Delay	3
Full Reconstitution	5
Demonstration Modes	7
ARIES	7
Live Flight	7
Demonstration Conduct	7
Controller Questionnaire Areas	9
SUMMARY OF DEMONSTRATION RESULTS	10
Comparison with ARTS III	11
Adequacy	11
Surveillance Quality	11
Tracking Quality	12
Full Reconstitution Configuration	12
Video Delay Configuration	13
Radar Tracking	13
Effect on ATC Procedures	14
Effect on Controllers' Workload	14
Alphanumeric Displays	14
Weather Display	15
Keyboard Entries	15
Demonstration Conduct	16
CONCLUSIONS	18

APPENDIX A: DEMONSTRATION RESULTS	A-1
INTRODUCTION	A-1
COMPILATION OF LOG SHEET RESPONSES, VIDEO DELAY	A-1
Track Position Symbols	A-1
Displayed Datablocks	A-1
Tabular Lists	A-2
Jitter and Automatic Offset	A-3
Weather Display	A-3
Video Displays	A-4
Keyboard Entries	A-4
Target Recognition	A-5
Surveillance Quality	A-5
Surveillance Delays	A-6
Miscellaneous Comments, Video Delay	A-6
COMPILATION OF THE DEBRIEFING FORMS RESPONSES, VIDEO DELAY	A-9
Rating of Evaluation Areas	A-10
Questions and Answers	A-13
COMPILATION OF LOG SHEET RESPONSES, FULL RECONSTITUTION	A-19
Track Position Symbol	A-19
Displayed Datablocks	A-19
Tabular Lists	A-19
Target Trail	A-20
Weather Display	A-20
Video Displays	A-20
Keyboard Entries	A-21
Surveillance Quality	A-21
Miscellaneous Comments, Full Reconstitution	A-22
COMPILATION OF DEBRIEFING FORMS RESPONSES, FULL RECONSTITUTION	A-22
Ratings of Evaluation Areas	A-23
Questions and Answers	A-26
SUMMARY OF DEBRIEFING SESSIONS	A-31
Debriefing Session of May 19	A-31
Debriefing Session of May 21	A-34

APPENDIX B: SCHEDULE OF THE DEMONSTRATION ACTIVITIES	B-1
APPENDIX C: DEMONSTRATION PARTICIPANTS	C-1
APPENDIX D: PHOTOGRAPHS OF CONTROLLERS' SCOPES	D-1

LIST OF ILLUSTRATIONS

FIGURE 1	VIDEO DELAY CONFIGURATION	4
FIGURE 2	FULL RECONSTITUTION CONFIGURATION	6
FIGURE D-1	EXAMPLE 1 OF CONTROLLER SCOPE IN VIDEO DELAY CONFIGURATION	D-2
FIGURE D-2	EXAMPLE 2 OF CONTROLLER SCOPE IN VIDEO DELAY CONFIGURATION	D-3
FIGURE D-3	EXAMPLE 1 OF CONTROLLER SCOPE IN FULL RECONSTITUTION CONFIGURATION	D-4
FIGURE D-4	EXAMPLE 2 OF CONTROLLER SCOPE IN FULL RECONSTITUTION CONFIGURATION	D-5
FIGURE D-5	EXAMPLE 3 OF CONTROLLER SCOPE IN FULL RECONSTITUTION CONFIGURATION	D-6

Accession For	
NTIS GRA&I	<input checked="" type="checkbox"/>
DTIC TAB	<input type="checkbox"/>
Unannounced	<input type="checkbox"/>
Justification	<input type="checkbox"/>
By	
Distribution/	
Availability Codes	
Avail and/or	
Dist	Special
A	

INTRODUCTION

During the week of May 18, 1981, a series of system demonstrations was conducted with a modified version of the Automated Radar Terminal System (ARTS III) which operates with Mode S surveillance data. These demonstrations took place at the Federal Aviation Administration (FAA) Technical Center with the participation of six field controllers from the Philadelphia Terminal Radar Approach Control (TRACON) facility. This report describes the system configurations used in the demonstrations and the conduct of the demonstrations, and summarizes the opinions and comments provided by the controllers.

Purpose

The purpose of the demonstration was to obtain an assessment by field controllers of some of the ATC-related aspects of the Mode S system operating in the terminal environment in order to determine whether or not any significant inadequacies or adverse impacts on the ATC function are evident in the system design.

Background

Mode S was developed by the FAA to provide improved surveillance. Three engineering models of the Mode S sensor were installed at, and in the vicinity of, the FAA Technical Center. These engineering models can provide surveillance reports to be processed at the Terminal Automation Test Facility (TATF), or the En Route System Support Facility (ESSF) at the Technical Center. The Technical Center has performed extensive technical as well as operational tests and evaluations to verify the performance of Mode S and its interfaces with both the terminal and en route facilities.

During the spring of 1981, ARD-100 and ARD-200 agreed that the experimental terminal system at the TATF, which was configured to operate with surveillance reports from the Mode S sensor, was adequate for an operational demonstration to field controllers. Such a demonstration, it was felt, would be useful to insure that the total Terminal ATC/Mode S system would not contain elements which may be objectionable in an operational environment. The system was then demonstrated to representatives of the Air Traffic Service from the FAA headquarters, who also concurred that controllers from the Philadelphia TRACON be given demonstrations of the system and be solicited for comments and opinions.

Scope

The demonstrations were deliberately of a limited nature, and should not be construed as a complete evaluation of the Terminal ATC/Mode S system. The intent was to show the system to controllers for a brief preliminary review and to obtain their first impressions of the system and its new features. Only two of the possible configurations were demonstrated, namely, the Video Delay and Full Reconstitution configurations, as described below. Only Time-Shared displays were presented, thus excluding Full-Digital display presentations. In addition, only the Mode S sensor located at the Technical Center was used to interface with the TATF in a single sensor configuration. The primary (search) radar data source was the Moving Target Detector (MTD) equipment located adjacent to the sensor at the Technical Center. The Radar Digital Acquisition System (RDAS) was not demonstrated.

Report Structure

The report contains four main sections and four appendices. The first section, Introduction, discusses the purpose, background and scope of this activity, and the structure of the report. The second section, Description of the Demonstration Missions, outlines the two configurations that were used with simulated and live flights, how the demonstrations were conducted, and the controllers' questionnaire areas. The third section, Summary of Demonstration Results, contains excerpts of the most important comments and observations for each of thirteen major functional areas. The fourth section, Conclusions, briefly states the major findings from the demonstrations. The appendices include a compilation of the controllers' comments and opinions collected during and after the runs, a schedule of the demonstration activities, a list of participants, and photographs of representative controllers' scopes for the two configurations.

DESCRIPTION OF THE DEMONSTRATION MISSIONS

Demonstration Configurations

Two system configurations were demonstrated, Video Delay and Full Reconstitution, as described below.

Video Delay

In this configuration, as depicted in Figure 1, primary radar returns are displayed through video delay equipment, while beacon reports (ATCRBS as well as Mode S) are processed by the Mode S sensor and transmitted to both the terminal system and the Video Reconstitutor for display on the controllers' scopes. The terminal system is ADS2, namely, version 2 of the All Digital (terminal) System. ADS2 is a non-correlating user, meaning that all target-to-track correlations are performed by the Mode S sensor which assigns a surveillance file number (SFN) to each target report transmitted to ADS2. ADS2 performs tracking (i.e., smoothing and prediction) and displays the standard alphanumeric and target symbol information on the controller's scope. This information includes the track data blocks, tabular lists, system displays, and keyboard entry preview area. Photographs of these displays are shown in Appendix D.

The primary radar returns, coming through the ASR-7 equipment, are processed by the Video Delay Generator (VDG). The VDG delays the normal radar returns prior to their display on the scopes. This is done to bring radar video and reconstituted beacon video into registration on the controllers' displays.

In the Video Delay configuration, the analog video display (broadband) of the primary radar returns appears similar to today's ARTS III display. The beacon slashes, however, are synthetic displays produced by the Video Reconstitutor unit. The Video Reconstitutor receives digital target data from the Mode S sensor via modems and a telephone line and then produces an analog beacon slash of 46 azimuth change pulses (ACPs) in azimuth extent. Each ACP is equivalent to 0.088 degrees. The azimuth extent of the slash is a site-adaptable parameter. Uncorrelated reports (i.e., no surveillance file number) are displayed as slashes with half azimuth extents. Pictures of the display in the Video Delay configuration are shown in Appendix D.

FIGURE 1
VIDEO DELAY CONFIGURATION

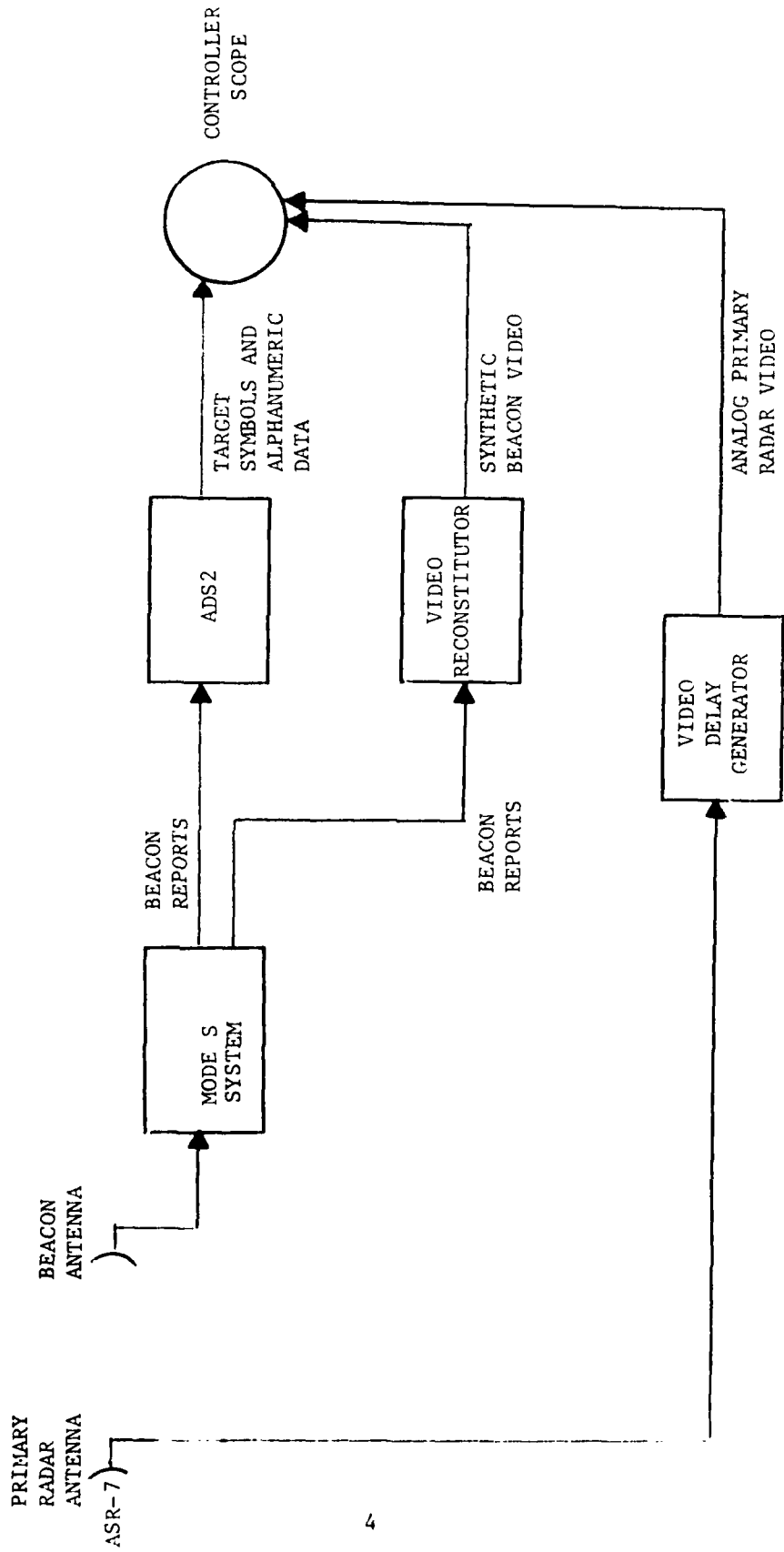

Two versions of the Video Delay configuration exist, i.e., with or without primary radar tracking. In the demonstrations, ADS2 did not perform tracking of non-beacon equipped aircraft (i.e., primary radar only) while in the Video Delay configuration.

Full Reconstitution

In this configuration, as depicted in Figure 2, reconstituted beacon as well as reconstituted radar video data are displayed on the controllers' scopes. Digitized radar target reports and weather messages are generated by the MTD and transmitted to the Mode S sensor. This sensor tracks the beacon and radar targets, and creates target reports for processing by the ADS2 system. ADS2 processes these messages and displays the appropriate symbols and alphanumeric data on the controllers' scopes (see Appendix D).

Tracking of radar targets, i.e., aircraft not equipped with a beacon transponder, is provided, as ADS2 tracks all aircraft that were successfully correlated by the Mode S sensor. Unassociated radar tracks are displayed as virgules (/). The controller can manually assign an aircraft identification (ACID) to an unassociated radar track, thereby converting it to an associated track displayed with a standard full datablock except that the letters "RDR" are displayed in place of the altitude on the second line of the datablock.

The Video Reconstitutor generates analog target slashes representing beacon and radar returns. Beacon slashes are 46 ACPs (system parameter) in azimuth extent as discussed in the preceding section, while radar slashes are 30 ACPs (system parameter) in azimuth extent and 1/16 nm in range extent.

In addition to reconstituting beacon and radar target reports, the Video Reconstitutor processes the digitized weather reports generated by the MTD and transmitted through the Mode S sensor, and also creates a synthetic image of the weather display. The Video Reconstitutor also provides a parallel radar channel to the display in the event of an ARTS III failure. During the week of May 18, no significant adverse weather was present in the vicinity of the Technical Center so this feature was not demonstrated. Photographs of the display (taken subsequent to the demonstration), including the weather representation produced by the Video Reconstitutor, are shown in Appendix D.

FIGURE 2

FULL RECONSTITUTION CONFIGURATION

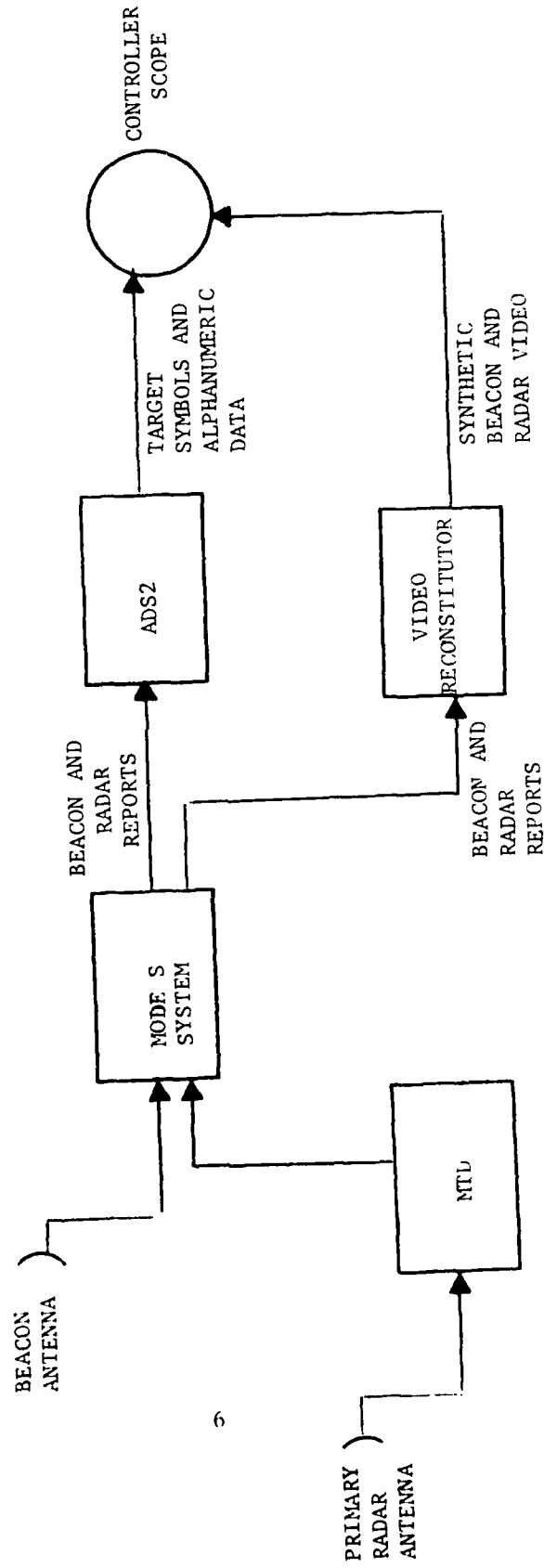

Demonstration Modes

The demonstrations presented to the field controllers included two modes of operation: Simulation using the Aircraft Reply and Interference Environment Simulator (ARIES) equipment at the Technical Center, and live flights using an aircraft equipped with a Mode S transponder. These modes are described below.

ARIES

The ARIES was used to simulate Mode S and ATRBS aircraft at approximately a 50/50 mix. The simulated scenario was built to resemble aircraft arrival and departure patterns as normally experienced in the Philadelphia International Airport environment. In addition to the simulated aircraft, the system detected and processed targets of opportunity at a radius of approximately 50 nm around the Technical Center.

Live Flight

Several runs were made using an aircraft (Cessna 172, rented by the Technical Center) equipped with a TRU-2 Mode S transponder. The pilot was in radio communication with the flight coordinator stationed at the TATF. During the run, the aircraft performed various typical maneuvers, such as, radial and tangential flights, flying in the cone-of-silence, touch-and-go flights, flying over ground clutter areas, and landings and takeoffs at the Ocean City and Smithville airports. During some of these flights the Mode S transponder was disabled, and the aircraft was displayed as a radar-only track. In addition to the test aircraft, the beacon and radar returns for targets of opportunity in the vicinity of the Technical Center were detected and processed by the system and displayed on the controllers' scopes.

Demonstration Conduct

The demonstrations were conducted over a four-day period, May 18 to May 21, 1981. Two groups of three controllers each participated in two days of demonstrations and discussions. Each group of controllers was presented with an orientation briefing discussing the general characteristics of Mode S, the configurations to be demonstrated, and the differences between ARTS III and the demonstrated system. Each orientation session concluded with a visit to the Mode S sensor site.

Four demonstration runs were presented to each group of controllers:

1. ARIES - Video Delay configuration
2. ARIES - Full Reconstitution configuration
3. Live flight - Full Reconstitution configuration
4. Live flight - Video Delay configuration

During the demonstration runs, each controller was assigned an observer who assisted in filling out the log sheets and answering any questions relating to the new display characteristics. After each run, the controllers and observers filled out debriefing questionnaires summarizing the observations made during the run and responding to specific questions on the various characteristics of the system.

Due to a temporary malfunction in the TATF, a planned side-by-side presentation of the demonstrated system vs. the current ARTS III was not possible. However, broadband video (search and beacon) as in the current ARTS III system was displayed at all times on three scopes along the left wall of the TATF.

A debriefing meeting with the controllers and observers was held at the conclusion of each two-day series of the demonstration sessions. This was done in order to offer the participants an opportunity to express their opinions on the demonstrated system, to review the controllers' reactions on the various characteristics of the system, and to discuss any issues related to terminal ATC operations in Mode S surveillance environment.

Controller Questionnaire Areas

The controller questionnaires and log sheets were structured so as to focus the controllers' attention and their comments on the overall system capabilities and characteristics which must be determined in order to guarantee a successful operational deployment of the future terminal system when operating with Mode S surveillance data. In reference to each of the system characteristics, as listed below, the demonstration participants were requested to consider the system from two perspectives:

- 1) Comparison with ARTS III - Relative to the present ARTS III system, does the demonstrated system offer the same, improved, or degraded capabilities?
- 2) Adequacy - Would the demonstrated system be adequate for use in an operational terminal ATC facility? What functions, if any, should be added, modified, or eliminated?

The controllers were asked to consider the following characteristics of the demonstrated system:

- (1) Surveillance Quality (e.g., detection, false targets, etc.)
- (2) Tracking Quality (e.g., track drops, swaps, coasts, time to initiate)
- (3) Reconstituted Video
- (4) Effect (if any) on ATC Procedures
- (5) Effect (if any) on Controllers' Workload
- (6) Alphanumeric Displays (e.g., datablocks, tabular lists, target symbols, etc.)
- (7) Keyboard Entries

In addition to the above, the controllers were encouraged to consider any other characteristics of the demonstrated system which might have an operational significance on the system adequacy from the technical aspect as well as its man-machine interface features.

SUMMARY OF DEMONSTRATION RESULTS

This section summarizes the most important comments and observations made by the demonstration participants. The summary includes general statements on the overall performance and utility of the demonstrated system as well as specific observations on some special components of the system which may need further work. Where applicable, references are made to other sections in the report in which the specific areas are discussed in more detail.

To facilitate the reviewing of the general and specific findings, the comments and observations were grouped into thirteen areas, as follows:

1. Comparison with ARTS III
2. Adequacy
3. Surveillance Quality
4. Tracking Quality
5. Full Reconstitution Configuration
6. Video Delay Configuration
7. Radar Tracking
8. Effect on ATC Procedures
9. Effect on Controllers' Workload
10. Alphanumeric Displays
11. Weather Display
12. Keyboard Entries
13. Demonstration Conduct

Comparison With ARTS III

In general, the majority of the participants felt that the system in either of the two configurations which were demonstrated, was for the most part equal, and in some respect better, than ARTS III. The capability to track and display datablocks and tabular lists for non-beacon equipped aircraft, not currently provided in ARTS III, was considered to be a definite improvement over ARTS III.

The surveillance delays introduced in both configurations (i.e., lag in displays of the reconstituted beacon and radar slashes and the broadband primary radar slashes) did not appear significant in the controllers' opinions (see subsection on Surveillance Delays in Appendix A, section on Compilation of Log Sheet Responses, Video Delay, and item 10 in Appendix A, section on Debriefing Session of May 19).

Adequacy

In general, the participants felt that the demonstrated system, in either of the two configurations, is conceptually adequate for ATC operations, and it could be deployed without any substantial impact on the controller. However, it was also stated that a comprehensive test and evaluation activity is needed.

Surveillance Quality

The demonstrated system provides improved surveillance relative to the current ARTS III in Philadelphia in terms of detection probability, radar reflections, and ground clutter. Also, the altitude (Mode C) reports in the demonstrated system appear to be more reliable (see item 4 in Appendix A, section on Debriefing Session of May 21). The question was raised whether the improved surveillance was due to a better system or different environmental conditions in the Technical Center relative to Philadelphia. Further testing of surveillance performance under stringent conditions similar to those existing at Philadelphia is needed (see item 3 in Appendix A, section on Debriefing Session of May 21).

A suggestion was made that future tests be conducted to verify surveillance and tracking in weather conditions and ground clutter areas.

Tracking Quality

Tracking in the demonstrated system was generally felt to be better than tracking at Philadelphia, although this should be attributed, to a great degree, to the improved surveillance of the demonstrated system relative to Philadelphia (see preceding section on Surveillance Quality).

The controllers were in favor of the track-all capability (not currently available in ARTS III) in the demonstrated system, and the resultant ability to display groundspeed and altitude (if Mode C equipped) for unassociated tracks (i.e., no flight identification).

Several instances were observed in which tracking performance was questionable (see items 14 and 15 in Appendix A, section on Miscellaneous Comments, Video Delay).

No continuity exists between a Mode S track and the subsequent radar-only track if the transponder is disabled (see item 2 in section on Miscellaneous Comments, Full Reconstitution). The same comment also applies to the case where an ATRBS track converts to a Mode S track (see item 3 in Appendix A, section on Miscellaneous Comments, Full Reconstitution, and response to Question No. 5 in Questions and Answers in Appendix A, section on Compilation of Debriefing Forms Responses, Full Reconstitution. Also, item 7 in Appendix A, section on Debriefing Session of May 19).

Full Reconstitution Configuration

Generally, the Full Reconstitution configuration was felt to be better than ARTS III and the Video Delay configuration. The primary reasons: (1) The elimination of radar clutter provides for a "cleaner" display, and (2) the capability to track radar-only aircraft (i.e., non-beacon equipped) was considered by the controllers to be a significant improvement.

The controllers did not consider as objectionable the fact that, unlike the analog target displays in the current ARTS III, all beacon slashes look alike and all radar slashes look alike, regardless of the strength of the beacon and radar returns.

A suggestion was made that the overlap or the amount of offset between the beacon and radar slashes be controller-adjustable (see item 6 in Appendix A, section on Miscellaneous Comments, Video Delay, and item 11 in Appendix A, section on Debriefing Session of May 19).

Several suggestions were made regarding the size of the beacon slash: (1) Reduce the length of the beacon slash especially at the longer ranges (see subsection on Video Displays in section on Video Delay Configuration); (2) Make the length of the slash controller-adjustable (see item 7 in section on Miscellaneous Comments, Video Delay); (3) Set the length of the slash as a function of the azimuthal accuracy of the target reports (see item 12 in Appendix A, section on Debriefing Session of May 19); (4) Make the slash fixed in length beyond a specified range on the scope (see item 6 in Appendix A, section on Debriefing Session of May 21).

One controller suggested that the double beacon slash indicating a "squawk ident" be changed to a wide (i.e., filled in) slash (see item 13 in Appendix A, section on Miscellaneous Comments, Video Delay).

Video Delay Configuration

In this configuration, the display characteristics were generally similar to ARTS III with some exceptions. One such exception, the reconstituted beacon slash, was felt to be acceptable.

Several suggestions were made in reference to the length of the reconstituted beacon slash (see the preceding section on Full Reconstitution Configuration).

Radar Tracking

Tracking of non-beacon equipped aircraft was demonstrated in the Full Reconstitution configuration. (The Video Delay configuration did not include radar-only tracking. However, a version of the system exists at the Technical Center which provides radar-only tracking in the Video Delay configuration.) The controllers' consensus was that radar-only tracking is a worthwhile feature in ATC operations.

However, several controllers noted that the occurrences of false radar tracks might be objectionable and distracting to the ATC controller (see Appendix A, subsection on Video Displays in section on Compilation of Log Sheet Responses, Full Reconstitution, and item 14 in Appendix A, section on Debriefing Session of May 19. Also, item 7 in Appendix A, section on Debriefing Session of May 21).

Effect on ATC Procedures

The controllers felt that no major procedural changes will be required for terminal ATC under Mode S surveillance, except for the following areas (see items 3 and 5 in Appendix A, section on Debriefing Session of May 19):

- 1) Handoff procedures involving Mode S-equipped aircraft
- 2) Phraseology for enunciating the Mode S address
- 3) Communications between Mode S and ARTS facilities
- 4) Inclusion of Mode S address in flight plans

Effect on Controllers' Workload

Most controllers felt that the system as demonstrated is expected to make no significant difference on controllers' workload. However, it was noted that the new ATC procedures which need to be developed to handle Mode S aircraft (see preceding section on Effect on ATC Procedures) may imply an increased level of controllers' workload. This area needs to be explored further (see item 10 in Appendix A, section on Debriefing Session of May 21).

Alphanumeric Displays

Generally, the participants noted that the displays of datablocks and tabular lists are similar to ARTS III. The several new display characteristics were considered either acceptable (e.g., hexagon indicating Mode S) or better than ARTS III (e.g., altitude display in the suspense list).

The radar-only track symbol (i.e., virgule) in the Full Reconstitution configuration was generally considered acceptable. One controller, however, suggested that this symbol be changed to reduce the clutter at the center of the scope (see subsection on Track Position Symbol in Appendix A, section on Compilation of Log Sheet Responses, Full Reconstitution).

Most controllers suggested that the full datablocks include a special indicator to denote a Mode S-equipped aircraft (see subsection on Displayed Datablocks in Appendix A, section on Compilation of Log Sheet Responses, Video Delay, and item 2 in Appendix A, section on Debriefing Session of May 19).

No reservations were expressed with regard to the display of "RDR" in the datablock to indicate track updates based on radar substitution reports.

Several other observations which were felt by the controllers to warrant future investigation are listed below:

- 1) The demonstrated system does not display virgules in the arrival and departure list for aircraft with duplicate ATCRBS code (see subsection on Tabular Lists in Appendix A, section on Compilation of Log Sheet Responses, Video Delay).
- 2) The Mode S address is displayed in duplicate upon entry of "multi-function, B, enter". It was suggested that the display be changed to include the ATCRBS code and a Mode S address (see item 8 in Appendix A, section on Miscellaneous Comments, Video Delay).
- 3) Blinking of ATCRBS code when a datablock is initiated for a Mode S-equipped aircraft (see item 1 in Appendix A, section on Debriefing Session of May 19).

Weather Display

No significant adverse weather conditions existed during the demonstration period, and, therefore, the new weather display characteristics could not be shown to the controllers. Future evaluations should include a thorough examination of the weather displays in both configuration (see subsections on Weather Display in Appendix A, sections on Compilation of Log Sheet Responses, Video Delay, and Compilation of Log Sheet Responses, Full Reconstitution, and item 13 in Appendix A, section on Debriefing Session of May 19).

Keyboard Entries

Some, but not all, keyboard entries were used in the demonstrations. The controllers noted that, generally, the keyboard entries were similar to those in ARTS III.

The implied track drop entry, a useful feature in ARTS III, does not work in the demonstrated system. This should be corrected (see subsection on Keyboard Entries in Appendix A, section on Compilation of Log Sheet Responses, Video Delay).

It is not possible to identify a Mode S address in the keyboard entry if the first character of the address is alphabetic (see subsection on Keyboard Entries in Appendix A, section on Compilation of Log Sheet Responses, Full Reconstitution).

The error message "ILL Mode S" should be displayed instead of "ILL 3/A" when a Mode S address is entered instead of an ATCRBS code.

Demonstration Conduct

In general, the controllers felt that the demonstration was worthwhile and that it was suitable for demonstrating the operational capabilities of the terminal ATC system when interfaced with Mode S surveillance.

Several suggestions were made with regard to future such demonstrations:

- 1) Demonstrate the system to controllers from a variety of terminal sites (see item 13 in Appendix A, section on Debriefing Session of May 21).
- 2) Demonstrate handoff procedures for Mode S aircraft.
- 3) Use several Mode S-equipped aircraft with a variety of flight maneuvers (see item 17 in Appendix A, section on Debriefing Session of May 19).
- 4) For a better comparative evaluation, provide ARTS III displays alongside the demonstrated system (see item 19 in Appendix A, section on Debriefing Session of May 19, and item 14 in Appendix A, section on Debriefing Session of May 21).
- 5) Demonstrate a backup mode for cases of subsystem failures (see item 15 in Appendix A, section on Debriefing Session of May 21).
- 6) Investigate the operational need for 1212-decoder type display (see item 4 in Appendix A, section on Debriefing Session of May 19).
- 7) Emphasize the role of live flights in future demonstrations, rather than simulation runs (see item 16 in Appendix A, section on Debriefing Session of May 21).

Several comments were made relative to the quality of the test bed used for the demonstrations. Most importantly, the reliability of the test bed was questioned since several system outages occurred during the demonstrations. Also, the time to restart the system after an abort was felt to be excessive (see items 4, 10, and 12 in Appendix A, section on Miscellaneous Comments, Video Delay, and seventh response to Question No. 5 in Questions and Answers in Appendix A, section on Compilation of Debriefing Forms Responses, Video Delay. Also, item 1 in Appendix A, section on Debriefing Session of May 21).

The controllers' scopes in the TATF had the following deficiencies:

- 1) The left-most scope was of poor quality (see item 5 in Appendix A, section on Miscellaneous Comments, Video Delay, and item 18 in Appendix A, section on Debriefing Session of May 19).
- 2) Occasionally, there was noticeable jitter of alphanumeric displays (see subsection on Jitter and Automatic Offset in Appendix A, section on Compilation of Log Sheet Responses, Video Delay, and item 1 in Appendix A, section on Miscellaneous Comments, Video Delay).
- 3) The scopes appeared to be set at an excessively high intensity level (see Appendix A, subsection on Surveillance Quality in section on Compilation of Log Sheet Responses, Video Delay, and item 8 in Appendix A, section on Debriefing Session of May 19).
- 4) The MTI gate control does not appear to function properly (see item 3 in Appendix A, section on Miscellaneous Comments, Video Delay, and item 1 in Appendix A, section on Miscellaneous Comments, Full Reconstitution. Also, item 20 in Appendix A, section on Debriefing Session of May 19).
- 5) The radar sweep stops intermittently (see item 9 in Appendix A, section on Miscellaneous Comments, Video Delay).

CONCLUSIONS

The purpose of the demonstration was to obtain an assessment by field controllers of some of the ATC related aspects of the Mode S system in order to determine whether or not any significant inadequacies or adverse impacts on the ATC function are evident in the system design.

While the demonstration was intentionally limited in scope, both from the standpoint of system capabilities demonstrated and the number of controllers involved, the following conclusions can be drawn:

1. The demonstrated system is conceptually adequate for ATC operations.
2. Of the two configurations demonstrated, the Full Reconstitution Configuration was generally preferred over the video Delay Configuration and was also considered an improvement over the current ARTS III in the following respects:
 - a. The targets of uniform brightness and the reduction of radar clutter produce a "cleaner" display.
 - b. The capability to track and display datablocks and tabular lists for non-beacon equipped aircraft was considered an improvement over the current ARTS III.
3. The demonstrated system appears to the controllers to provide improved surveillance in terms of detection probability, radar reflections, ground clutter and Mode C altitude report reliability as compared with the Philadelphia ARTS III.*
4. There were no apparent significant negative impacts of the demonstrated system features on either ATC procedures or controller workload.
5. Beacon targets and radar targets of uniform brightness, regardless of the strength of the beacon and radar returns, were not objectionable to controllers.

* It is reasonable to assume that part of this perceived improved performance is attributable to the more benign environment at the Technical Center as compared to the Philadelphia terminal area.

6. The small delays required to generate and display the reconstituted beacon and radar targets was insignificant to the controllers.
7. A more comprehensive evaluation would be required to provide quantitative measures of system performance and to more adequately assess important design areas (e.g., weather display, radar tracking) bearing on the operational acceptability of introducing Mode S into the ATC system.*

* See section on "Summary of Demonstration Results" for a list of controllers suggestions relative to a more comprehensive evaluation.

APPENDIX A

DEMONSTRATION RESULTS

INTRODUCTION

This Appendix contains a compilation of the controllers' opinions and comments collected during and after the demonstrations. The first subsection of this appendix presents a compilation of the log sheet responses and debriefing forms responses related to the Video Delay configuration. The next subsection presents the same information for the Full Reconstitution configuration. The last subsection is a transcript of the two debriefing sessions held in May 19 and May 21 at the conclusion of each series of demonstration runs.

COMPILATION OF LOG SHEET RESPONSES, VIDEO DELAY

The log sheet responses, collected during the runs, are grouped by separate functional areas related to the various display characteristics, keyboard entries, and surveillance aspects.

Track Position Symbols

In the Video Delay configuration, one new track position symbol was displayed, i.e., "○" indicating an unassociated Mode S track. All other position symbols (i.e., *, +, □, △) indicating unassociated tracks were the same as in the current ARTS III. Since no radar tracking was performed in ADS2 in this configuration, the special symbol (/) for a radar-only track was not displayed.

The general consensus was that the display of the unassociated Mode S symbol (○) was acceptable, although it usually appears more like a circle.

Displayed Datablocks

The controllers were requested to consider the displays of full and limited datablocks for Mode S and ATRBS tracks. For unassociated aircraft, limited datablocks containing groundspeed and altitude, if reported, could be obtained through a slewball-and-enter action. Since radar-only aircraft were not tracked in the Video Delay configuration, no datablocks were displayed unless the aircraft were beacon-equipped (i.e., ATRBS or Mode S).

The general consensus was that the datablock displays are essentially similar to those in ARTS III and are acceptable. A comment was made that restarting a track from the suspense list was immediate, as opposed to the standard ARTS III, and that this is a good feature of the ADS2 system.

Several controllers commented that no distinction exists between Mode S and ATRBS full datablocks. It was suggested that an indicator should be provided in the full datablock to denote a Mode S-equipped aircraft. (Note: Subsequent discussions with the controllers revealed that no compelling reason exists to require such an indicator, unless the data-link capability is operational.)

A comment was made that the full datablock for a Mode S aircraft should contain information on radio failure or emergency similar to the indication provided for ATRBS aircraft.

A comment was made that the displayed groundspeed and altitude (if Mode C-equipped) in the limited datablock (upon a slewball-and-enter action) for unassociated tracks was a good feature. (Note: This is due to the fact that ADS2, unlike ARTS III, tracks all aircraft, associated as well as unassociated.)

Tabular Lists

The tabular lists include information on coasted tracks (if coasted for more than a parameter number of scans), suspended tracks, and the status of arrival and departure flight plans. Essentially, the lists are similar to those in the ARTS III system, except for new symbols indicating Mode S and radar-only tracks: The hexagon (◻) for Mode S, and the letter "R" for a radar-only tracks. In the Video Delay configuration, only beacon-equipped aircraft (Mode S and ATRBS) appeared in the lists since no radar tracking was performed in this configuration.

The general consensus was that the displayed tabular lists were acceptable. One controller noted that the special indication given to coasted and suspended Mode S tracks was a good feature. Also, the reacquisition of a suspended track was much quicker than in the current ARTS III (Note: This is due to the track-all feature in ADS2).

It was noted that a virgule (/) was not displayed in the arrivals and departures list next to an aircraft with a duplicated discrete beacon code. In the current ARTS III, virgule is displayed to indicate a duplicate discrete beacon code.

It was also noted that when a Mode S aircraft is reacquired from the track suspense list, the ATRCBS code blinks in the datablock. Normally, an ATRCBS code blinks when the assigned beacon code is different from the reported code.

One controller observed that reacquisition of a suspended ATRCBS track was slower than that of a Mode S track.

One controller commented that, unlike the ARTS III track suspense list, the altitudes are displayed in the ADS2 suspense list. It was felt that this is a good feature.

A comment was made that the BRITE display tabular list was not shown in the demonstration. The current ARTS III provides on the BRITE scopes a list containing the ACIDs and aircraft types for the last three aircraft crossing the arrival automatic track drop parameter for the primary and secondary runways. (Note: No BRITE scopes were used in the demonstrations.)

Jitter and Automatic Offset

It was felt that the jitter in target position was acceptable, and generally similar or better than at the Philadelphia TRACON. One controller noted that occasionally there was a noticeable jitter in the tabular lists and in the controller symbol on some datablocks. Also, at times, the preview area had noticeable jitter. (A TATF trouble report was filed.)

The controllers noted that the automatic offset function was acceptable.

Weather Display

In the Video Delay configuration, normal weather clutter is generated through the ASR-7 equipment and then the Video Delay Generator for display on the controller scope. No weather processing is performed in the MTD or the Video Reconstitutor. Therefore, in this configuration, the weather display is expected to be essentially the same as in the current ARTS III. During the demonstration runs, no significant weather conditions existed except for several hours on the morning of May 19 when a light weather cell appeared approximately 30 nm northeast of the antenna. The display of this weather cell as generated through the ASR-7 was identical to that generated through the ASR-4 on the auxiliary system displays (along the left wall of the TATF display room).

Video Displays

In the Video Delay configuration, the primary radar slashes are broadband displays which are delayed by the Video Delay Generator, while the beacon slashes for Mode S and ATRBS aircraft are created through the Video Reconstitutor.

Generally, the controllers felt that the reconstituted beacon slashes were good. The broadband primary radar slashes appeared generally to be better (i.e., more distinct, clearer, and more consistent) than at Philadelphia.

The displays of half-size slashes indicating uncorrelated reports were acceptable as these are usually displayed only for a period of one or two scans.

One controller felt that the length of the beacon slash should be reduced, especially at longer ranges from the antenna.

The ground clutter in the Video Delay configuration was generally felt to be less severe than at Philadelphia.

Keyboard Entries

During the demonstrations, the controllers were requested to enter at random some of the most frequently used keyboard entries and to compare subjectively, based on their experience, the keyboard input operations in ADS2 with ARTS III.

It was found that the implied track drop entry, which causes a track drop in ARTS III upon a slewball-and-enter action, does not work in ADS2. The controllers felt that this feature should be available in ADS2 since it is heavily used in normal ATC operations.

Other than as stated above, the keyboard operations--although only a few keyboard entries were used--appeared generally to be similar to ARTS III. Response time appeared to be slightly faster in ADS2 than in ARTS III. However, one controller noticed a delay when a Mode S track was reacquired from the track suspense list when the ATRBS code was used for the reacquisition.

Target Recognition

The ability to distinguish and identify targets based on the reconstituted beacon slash and the broadband primary radar slash was generally felt to be better in comparison to the ARTS III in Philadelphia.

Surveillance Quality

Unanimously, the controllers felt that the overall surveillance quality of the demonstrated system was better than that at the Philadelphia ARTS III facility. The following is a collection of comments made by the controllers:

- 1) The demonstrated system had far fewer coasting tracks than at Philadelphia.
- 2) Detection in the cone-of-silence is much better in the demonstrated system.
- 3) Ground clutter is much reduced relative to Philadelphia.
- 4) Detection upon landing and take-off is better in the demonstrated system.
- 5) Track initiation time is faster in the demonstrated system.
- 6) Track/target correlation is better in the demonstrated system; in Philadelphia the track position at times seems to "drift off".
- 7) Frequency of tracks dropping into TAB-COAST is much less in the demonstrated system.
- 8) Detection of primary radar-only targets is better in the demonstrated system.
- 9) The occurrences of false radar targets are less in the demonstrated system.
- 10) Better detection of primary radar targets at a range of 20 nm and beyond, as compared to Philadelphia.

- 11) Philadelphia has more radar noise, reflections, and misdetections.
- 12) The demonstrated system detected primary radar-only aircraft (i.e., non-beacon equipped) flying at 2000 feet at a range of 35 nm. Such aircraft are not normally detected in Philadelphia.
- 13) There was good tracking of two Mode S aircraft when both were in the same range and azimuth (separated by altitude). They went into coast for only one scan. In Philadelphia, two beacon aircraft in such proximity would go into coast for most of the time.

One controller felt that the beacon and radar slashes for the same aircraft should be closer in proximity.

In all the runs, a number of beacon and radar reflections were observed southeast of the antenna. (Note: This is a known area of reflections at the Technical Center.)

One controller commented that the scope contained a high degree of electronic noise (exhibited as many dots following the sweep) because the intensity level of the display was too high. (Note: This is a test bed problem. If the intensity level is reduced, then the display of video slashes is too weak.)

Surveillance Delays

In the demonstrated system, unlike ARTS III, the video displays of target positions are updated after the alphanumeric datablock information. This is due to the lag between the actual antenna position and its display on the scope. The controllers were requested to observe this delay and to note whether they felt the delay was acceptable, negligible, or significant. Unanimously, the controllers responded that the delay seemed to be negligible and of no significance to ATC operations.

Miscellaneous Comments, Video Delay

Other comments made by the controllers on the log sheets are provided below.

- 1) There was an unsteady flicker of the background lighting of the scope. This could be due to high setting of the display intensity level.

- 2) No 1212-decoder equipment was used in the demonstrations (see item 4 in Appendix A, section on Debriefing Session of May 19).
- 3) In the Video Delay configuration, the MTI gate control, on the upper left corner of the scope, functions in a manner opposite to standard ARTS III. Normally, in ARTS III, the gate is used to inhibit clutter in the vicinity of the antenna, while at the TATF the gate control inhibits clutter beyond the radius defined by the gate. (A TATF trouble report was filed.)
- 4) There seems to be a test bed reliability problem. It takes a relatively long time to bring up the system.
- 5) The first scope from the left is not of good quality. The analog data displays do not show very well. Also, the intensity of ground clutter is far below what it should be, and the persistency of the video display is below normal. (A TATF trouble report was filed.)
- 6) Some controllers preferred that the beacon and primary radar slashes be slightly offset for easier distinction, while others felt that the slashes should completely overlap. In the current ARTS III system, the offset is controlled through hardware and can be adjusted by the radar technician. Each ARTS III site has the option to select the amount of offset, and the setting varies from site to site. A suggestion was made that a controller-adjusted offset capability should be provided.
- 7) One controller suggested that the length of the beacon slash should be adjustable by the controller through a special switch on the scope's controls panel.
- 8) Currently, the Mode S address of an associated Mode S aircraft is displayed twice when the controller keys in "Multi-Function, B, enter". It was suggested that, instead, the ATRBS code should be displayed next to the Mode S address. This would also facilitate the pointing out of a Mode S aircraft when handed off to a non-Mode S facility.

- 9) It was noted by the controllers that during the morning test on May 19 (Video Delay configuration) the radar sweep on all the scopes stopped and restarted intermittently many times. (A TATF trouble report was filed.)
- 10) It was noted by the controllers that on May 20 at 13:40, during the Video Delay run, all alphanumeric data displays on all the scopes were lost for approximately 10 minutes. (Note: A quick patch was supplied by UNIVAC to correct the problem.)
- 11) A comment was made that in the current ARTS III the controller can observe the "code train" for ATCRBS aircraft when the Analog/Beacon switch on the scope control panel is on the analog position. Since, in both Video Delay and Full Reconstitution configurations, all beacon slashes were reconstituted, the "code train" display could not be invoked by the controllers in the demonstration. However, the controllers noted that the "code train" display does not appear to be a necessary feature and its elimination is likely to be operationally acceptable. Note that the Video Reconstitutor can put out the "code train" display through a special switch setting provided in the hardware.
- 12) It was noted that on May 21 at 11:00, during the Video Delay run, all ATCRBS returns suddenly disappeared. It took ten minutes to restart the system.
- 13) The Video Reconstitutor displays a double beacon slash to indicate a "squawk ident" action. In the present ARTS III, a "squawk ident" is indicated by a wide (filled in) beacon slash. One controller suggested that the double slash be filled in since the wide beacon slash used in current ARTS III is more readily noticeable. However, another controller commented that the display of a double beacon slash was better (presumably, stronger intensity) than the "ident" indication in the current ARTS III display.
- 14) During the May 18 run, at time 13:42, an uncorrelated beacon return was observed at approximately 35 nm range and 205 degrees in azimuth. The aircraft remained uncorrelated for approximately five minutes before a track was started. (A TATF trouble report was filed.)

- 15) During the May 20 run, at 13:50, a radar-reinforced target was observed at a range of approximately 28 nm. No track was started on this target for approximately 15 minutes. Eventually, a track was started but automatically dropped and then restarted and so on again several times. (A TATF trouble report was filed.)
- 16) A noticeable jitter was observed on some of the characters included in the T&E table display (invoked using an F16 keyboard entry). (A TATF trouble report was filed.)

COMPILATION OF THE DEBRIEFING FORMS RESPONSES, VIDEO DELAY

At the conclusion of each run, the controllers and observers were requested to fill out debriefing forms summarizing observations and comments from the various demonstration areas. They were also requested to respond to specific questions included in the debriefing forms. The following is a compilation of the responses provided in the debriefing forms. Note that the responses include those of the six controllers from the Philadelphia TRACON plus two observers from the Technical Center who were certificated ATC specialists. The following information applies to the Video Delay configuration.

Rating of Evaluation Areas

The controllers were requested to rate, on a scale of 1 to 5, the Mode S/ATC performance as compared with today's ARTS III (ATCRBS tracking) system. Each controller assigned a subjective rating to each of the evaluation areas listed on the form. The forms were then analyzed to obtain the number of responses with 1 rating, 2 rating, etc., for each evaluation area. The table below reflects total responses for four Video Delay runs. In some cases, forms were not completely filled out. The ratings were as follows:

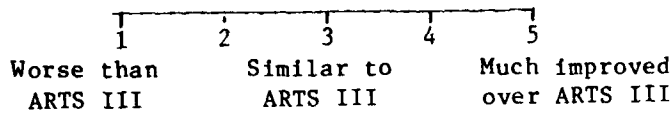

Evaluation Area	Rating*					Improvements Over ARTS III	Deficiencies as Compared with ARTS III	Controllers' Comments
	1	2	3	4	5			
<u>DISPLAYS</u>								
TARGET POSITION								
1) BEACON SLASH		1	8	5	2	Target resolution is better		The slashes** were too far apart
2) PRIMARY SLASH		1	6	5	2			
3) DIGITAL POSITION		1	7	4				
DATA BLOCKS			14	1				Symbol needed to identify Mode S aircraft. Same as ARTS III
WEATHER			5					Light weather present in one run
MAP			12					
TABULAR LISTS			16					Slight jitter
GENERAL DISPLAY QUALITY			10	4	2			

(*) Number of controllers' responses for each of the five ratings.

(**) Presumably refers to primary and beacon slashes for the same aircraft.

(continued)

Evaluation Area	Rating					Improvements Over ARTS III	Deficiencies as Compared with ARTS III	Controllers' Comments
	1	2	3	4	5			
<u>SURVEILLANCE</u>								
<u>DETECTION</u>								
TARGET DETECTION								
MODE S			6	8	1		No change in clutter or weather environment	
ATCRBS			5	9	1			
SEARCH			5	7	2			
FALSE TARGETS								
MODE S		1	3	6	2		Ground clutter problem	Only two false targets noted. Numerous false beacon targets in all quadrants
ATCRBS		2	3	6	2			
SEARCH		2	4	4	2			
MISSING TARGETS								
MODE S			4	5	2			
ATCRBS			4	5	2			
SEARCH			3	4	2			
<u>TRACKING</u>								
<u>COASTS</u>								
MODE S			4	5	5	Coast only for short durations. Definite improvement.		ARTS III can go into coast to suspend list
ATCRBS			5	5	4			
SEARCH			4	4	3			
TRACK DROPS								
MODE S	1		1*	5	3	2	Implied track drop does not work	
ATCRBS	1			5	4	2		
SEARCH				4	4	2		
TRACK INITIATION								
MODE S			5	4	2			
ATCRBS			6	4	2			
SEARCH			5	3	2			

(*) As recorded on the controllers' questionnaire forms.

(continued)

Evaluation Area	Rating					Improvements Over ARTS III	Deficiencies as Compared with ARTS III	Controllers' Comments
	1	2	3	4	5			
<u>CONTROLLER WORKLOAD</u>								
1) VOICE COMMUNICATIONS			8	1				No voice used No significant change
2) KEYBOARD ENTRIES			13					
3) OTHERS			2					

Questions and Answers

The controllers' responses to the questions are contained below. These were compiled from responses relative to four Video Delay runs. In some cases, forms were not completely filled out.

Question No. 1: Was the mission suitable for demonstrating the operational implications of Mode S/ATC?

Responses:

YES - 14 responses
PARTLY - 1 responses

Explanations and Comments:

"Mode S can be used without any substantial impact on controller"

"Track into ground clutter and weather"

"However compared to Philadelphia, this is a very uncluttered area"

"The ACY airspace lacks the clutter and traffic of Philadelphia. It is hard to get the true picture of the effectiveness of the system"

"It might be suggested to have the controller interact with the system in a realistic simulation or have an ARTS III that is in the field side by side with ARTS III using Mode S"

Question No. 2: In your opinion, can the system as demonstrated in this mission be used to upgrade an ARTS III facility?

Responses:

YES - 13 responses
"No change" - 1 response

Explanations and Comments:

"Only as far as Philadelphia is concerned. I believe other controllers from other facilities should be shown the system"

"No obvious major benefit to the controller. Search and beacon target displays are much better than Philadelphia"

"Apparent from the controller reaction that this system could upgrade the Philadelphia ARTS III system, but I don't have any opinion now"

"Mode S appeared to eliminate coast problems and provide service that was at least as good as ARTS III in all these areas"

"Yes. Assuming the stated accuracy is there (hardware-wise)"

Question No. 3: In your opinion, can today's separation standards be maintained with Mode S/ATC?

Responses:

YES - 13 responses

Explanations and Comments:

"As good as ARTS"

"No difference as for separation"

"Video delay (configuration) is very superior to Philadelphia"

"Without reservations, today's separation standards can easily be maintained"

Question No. 4: Please state the improvements which Mode S/ATC provides relative to today's ARTS III (ATCRBS tracking) system?

Responses:

"As good as ARTS III, but don't know if it is better"

"Mode S provides a more uniform target presentation and appears to have eliminated problems inherent in ARTS III"

"Less coast and track drops and false altitude readouts"

"Beacon reinforcement and better resolution"

"Better tracking close to the antenna at low altitude"

"Minimum time in coast"

"Speed and altitude acquire faster in data block. Much better search and beacon target display especially close to the antenna"

"Better retention of primary and beacon targets"

Question No. 5: Please state any problems or potential problems which exist, in your opinion, in the Mode S/ATC system.

Responses:

"What effect does shielding of the radar (i.e., blockage by tall structures, etc.) have on Mode S system?"

"Mode S indication in FDB needed"

"Interfacility automatic handoff procedures between Mode S and ARTS facilities" (Note: Apparently, the controller felt that this might be a problem.)

"Real primary aircraft target" (Note: It is not clear what the controller meant by this comment.)

"No problem noted"

"It appeared to have more jitter than normal (alphanumerics)"

"The system went down too often and it took awhile to restart"

Question No. 6: Do you foresee any potentially serious ATC problems and/or disadvantages which may develop should Mode S/ATC (as configured in today's mission) be implemented in the field?

Responses:

NO - 11 responses
YES - 1 response

Explanations and Comments:

"Only interfacility handoff" (Note: Apparently, the controller felt that this might be a problem.)

Question No. 7: Does the Mode S/ATC system increase, decrease, or make no difference relative to the workload of the ATC controller?

Responses:

NO DIFFERENCE - 12 responses
DECREASE - 1 response

Explanations and Comments:

"Mode S system seems to reduce many targets, such as birds and temperature inversion"

"However, datablocks have to be dropped with keyboard (entries) instead of slew"

"In a static demonstration as this, it is hard to evaluate effect on workload, if any"

Question No. 8: What new ATC procedures, if any, will be needed if Mode S/ATC were implemented in the field?

Responses:

NONE - 10 responses
"Cannot think of any" - 2 responses
"Need briefing on 6 digit code" - 1 response

Question No. 9: To what degree do you feel that replacement of today's ARTS III system with Mode S/ATC, as configured in today's mission, would enhance the terminal ATC operations?

Responses:

"Not obvious"

"Mode S would enhance terminal ATC operations to a small degree"

"It enhances it because you have an option" (Note: It is not clear what the controller meant by this comment.)

Explanations and Comments:

"Seems to be better radar coverage and less coasts"

"Don't think this mode would really enhance the system that much"

"At this time do not know if it would enhance terminal ATC operations"

"Mode S appears to acquire and hold a target better than ARTS III; more reliability"

"If an aircraft's Mode S equipment is not working he could return to beacon system with his transponder"

Question No. 10: Do you have any additional comments on the characteristics, implications, and adequacy of the Mode S/ATC system?

Responses:

NO - 8 responses

"In certain areas Mode S might drastically improve radar coverage which otherwise would not exist with ARTS III"

"The network concept has potential for improved safety"

Question No. 11: Do you have any suggestions on improvements which should or could be made to Mode S/ATC?

Responses:

NONE - 6 responses

"Interfacility handoff"

"Provide symbology in the FDB for Mode S-equipped aircraft"

"Have ID feature fill in double slash"

COMPILATION OF LOG SHEET RESPONSES, FULL RECONSTITUTION

Many of the comments made for the Full Reconstitution runs are virtually the same as those for the Video Delay runs. For the sake of brevity, the following compilation of controller responses includes only those comments which were not recorded previously. For a complete review of controllers' notes referring to each demonstration area, the reader should refer to the applicable subsection in the preceding section on Compilation of Log Sheet Responses, Video Delay.

Track Position Symbol

The only new track position symbol, in the Full Reconstitution configuration, was the virgule (/) representing a primary (i.e., radar-only) track. Generally, the controllers felt that this symbol was acceptable. One controller, however, suggested that the symbol be changed (presumably, to a smaller symbol) to reduce the clutter (arising from virgules generated due to ground clutter) about the center of the scope.

Displayed Datablocks

The controllers felt that the ability of the system to provide a datablock and groundspeed for radar-only targets was a definite improvement over ARTS III.

One controller noted that the display of the beacon code in the limited datablock for unassociated ATCRBS tracks is a good feature. This is not provided in Philadelphia.

Tabular Lists

In the Full Reconstitution configuration, the tabular lists (i.e., coast, suspense, arrivals and departures lists) apply equally as well to radar tracks, and special symbols are provided to indicate the radar-only tracks in the lists. The controllers felt that inclusion of radar-only tracks in the lists and the symbology that was used were good.

Target Trail

One controller felt that the video trail for search aircraft needs improvement. He noted that he believed the scope display equipment needed tuning.

Weather Display

In the Full Reconstitution configuration, the weather is processed by the MTD and the resultant weather messages are transmitted through the Mode S sensor to the Video Reconstitutor. This unit then generates a synthetic weather display on the controllers' scopes.

No severe weather conditions existed during the week of the demonstration. However, in the May 19 morning demonstration, a large cell of weather appeared northeast of the Technical Center. A call to the local weather bureau revealed that this was light weather (level 1). Although the weather area was clearly visible on the scope in the Video Delay configuration, no reconstituted weather was displayed in the Full Reconstitution configuration. The MTD technician explained that this was due to the setting of the threshold level in the MTD. However, one controller commented that the displayed weather in the Video Delay configuration appeared *sufficiently strong* to warrant the sending of weather advisories to aircraft in that area.

Video Displays

Several controllers felt that the number of occurrences of false radar tracks should be reduced. A radar track is displayed as a virgule (/). Usually, false tracks result in displayed virgules that are short-lived (2 to 3 scans) and have erratic moving patterns. The occurrences of such virgules are especially noticeable about the center of the scope, but they also appear intermittently at different ranges and azimuths. Several controllers noted that when a primary track symbol appeared they were not sure whether it was false or came from a real aircraft. This could be confusing and distracting. To insure safety, the controllers would have to vector aircraft around these false track symbols. This could result, according to the controllers, in increased controllers workload and unnecessary vectoring.

The controllers noted that the ground clutter, in the Full Reconstitution configuration, is much reduced and the display is much cleaner in appearance as compared with the Video Delay configuration and the current ARTS III display.

One controller questioned whether the high level of ground clutter in Philadelphia (relative to the Technical Center) would result in an excessive number of false radar tracks, even more than shown with the demonstrated system. Also, if an associated radar track exists in the vicinity of other false radar tracks, it would seem likely that some track swaps would occur causing a datablock to associate with some false track. One controller suggested that all virgules be inhibited in the area near the antenna to reduce clutter and false radar tracks at small ranges.

Another controller, on the other hand, remarked that "you can live with the false tracks around the antenna", but the number of occurrences of false tracks at longer ranges appears to be excessive since they require special attention from the controller and may contribute to increased workload.

Keyboard Entries

The controllers liked the fact that most of the keyboard entries that apply to beacon tracks also can be used for radar-only tracks.

One controller noted that ADS2 rejects all keyboard entries in which the aircraft identity is the Mode S address unless the first character of the address is a number from 0 to 9. Thus, for all aircraft whose Mode S address starts with the letters A through F, the identification by Mode S address cannot be used in the keyboard entries. (Note: This problem has been known for some time and a Mode S trouble report is outstanding. No adequate solution has yet been found.)

The new feature in ADS2 providing instant reacquisition of a track from the track suspense list was considered as a desirable improvement over ARTS III.

Surveillance Quality

The controllers liked the automatic tracking function for radar-only (no beacon) aircraft, and the related feature of being able to associate a radar-only target with an ACID. Also, the display of groundspeed for radar-only aircraft is a new feature, not currently available in ARTS III, and this capability was well received by the controllers.

Miscellaneous Comments, Full Reconstitution

- 1) In the Full Reconstitution configuration, the operation of the MTI on/off switch on the scope control panel is totally different from present ARTS III since the switch must be in the "on" position to display reconstituted primary slashes. Several controllers found this to be confusing.
- 2) When the Mode S transponder is turned off, the Mode S track drops and several scans later an unassociated radar-only track will start. The controller then has to manually associate the radar-only track with the appropriate ACID in order to invoke a full datablock display. By design, no track continuity is maintained between the Mode S track and the subsequent radar-only track. The controllers felt that the Mode S/radar track continuity should be maintained by the system.
- 3) Related to the above comment is the transition from an ATCRBS track to a Mode S track. Such transition occurred when the ATCRBS transponder was disabled and the Mode S transponder turned on. The ATCRBS track dropped after existing for several scans as a radar-substituted track, i.e., a beacon track based (temporarily) on radar-only target reports ("RDR" displayed in the datablock). Subsequently, a new unassociated Mode S track was started. The controllers felt that Mode S/ATCRBS track continuity should be maintained.
- 4) On May 21, when a datablock was created for the stationary Mode S transponder in Mizpah (address "FAADAB"), the MSAW inhibit indicator (an asterisk following the ACID) appeared automatically. This does not seem to be correct. (A TATF trouble report was filed.)

COMPILATION OF DEBRIEFING FORMS RESPONSES, FULL RECONSTITUTION

The following is a compilation of the debriefing responses received from the controllers and observers for the Full Reconstitution demonstrations.

Ratings of Evaluation Areas

The controllers were requested to rate, on a scale of 1 to 5, the Mode S/ATC performance as compared with today's ARTS III (ATCRBS tracking) system. (See explanation on the corresponding table in the preceding section on Compilation of Debriefing Forms Responses, Video Delay.) The compiled ratings from controllers' responses as collected from three Full Reconstitution runs were as follows:

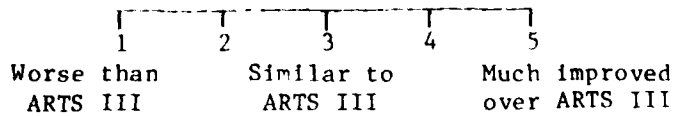

Evaluation Area	Rating*					Improvements Over ARTS III	Deficiencies as Compared with ARTS III	Controllers' Comments
	1	2	3	4	5			
<u>DISPLAYS</u>								
TARGET POSITION								
1) BEACON SLASH			5	5	1			Better clarity. If possible reduce length of beacon slash
2) PRIMARY SLASH			5	4	1			
3) DIGITAL POSITION			5	3				
DATA BLOCKS			8					
WEATHER			1	2	1	Light rain eliminated		Cleaner scope on significant weather
MAP			7	1				
TABULAR LISTS			10					
GENERAL DISPLAY QUALITY			3	6	2	Reduced clutter for same resolu- tion of primary targets		No ground clutter. Less clutter

(*) Number of controllers' responses for each of the five ratings.

(continued)

Evaluation Area	Rating					Improvements Over ARTS III	Deficiencies as Compared with ARTS III	Controllers' Comments
	1	2	3	4	5			
<u>SURVEILLANCE</u>								
<u>DETECTION</u>								
TARGET DETECTION								
MODE S			4	5				
ATCRBS			4	5				
SEARCH			1	5	4			
FALSE TARGETS								
MODE S	1	3	2	4				A number of false radar targets near the antenna
ATCRBS	1	3	2	3				
SEARCH	1	2	4	1				
MISSING TARGETS								
MODE S			3	3	2			
ATCRBS			3	3	2			
SEARCH			2	4	1			
OTHER								
					1			
<u>TRACKING</u>								
<u>COASTS</u>								
MODE S			3	3	4			
ATCRBS			3	3	4			
SEARCH			2	4	2			
TRACK DROPS								
MODE S	2	2	4	2				No implied track drop function
ATCRBS	2	2	4	2				
SEARCH	1	2	4	2				
TRACK INITIATION								
MODE S	1	4	3	2				4096 code flash
ATCRBS		4	4	2				
SEARCH		4	3	2				

(continued)

Evaluation Area	Rating					Improvements Over ARTS III	Deficiencies as Compared with ARTS III	Controllers' Comments
	1	2	3	4	5			
<u>CONTROLLER WORKLOAD</u>						No effect		No implied track drop
1) VOICE COMMUNICATION			5					
2) KEYBOARD ENTRIES		2	8					
3) OTHERS			1					

Questions and Answers

The compiled responses to questions for three Full Reconstitution runs were as follows:

Question No. 1: Was the mission suitable for demonstrating the operational implications of Mode S/ATC?

Responses:

YES - 9 responses
Not exactly - 1 response
Somewhat - 1 response
Partly - 1 response

Explanations and Comments:

"A Mode S aircraft entering the system would possibly increase workload initially but, if interfacility handoffs were possible, it would reduce workload later". (Note: Apparently, the controller was unsure as to how handoff procedures would work in Mode S environment.)

"I was still unable to see tracking through weather areas and ground clutter"

"There was only one live Mode S aircraft"

Question No. 2: In your opinion, can the system as demonstrated in this mission be used to upgrade an ARTS III facility?

Responses:

YES - 10 responses
MAYBE - 1 response

Explanations and Comments:

"Although unfamiliar with ARTS IIIA, ability to track primary targets is a definite improvement"

"More capability"

"A significant improvement noted"

Question No. 3: In your opinion, can today's separation standards be maintained with Mode S/ATC?

Responses:

YES - 11 responses

Explanations and Comments

"Although this appears to pertain to reliability, I observed no problem with Mode S maintaining targets"

"Mode S has better primary and beacon retention"

Question No. 4: Please state the improvements which Mode S/ATC provides relative to today's ARTS III (ATCRBS tracking) system?

Responses:

"Cleaner scope"

"Improved tracking"

"Track primary"

"Ability to track primary targets, enhanced WX display, updating tag position first then correlating this with the beacon target"

"Elimination of ground clutter"

"Ability to have network of sensors"

"Weather returns appear more beneficial in the vicinity of significant weather". (Note: It is not clear what the controller meant by this comment.)

"Better primary and beacon targets, with less coasts"

Question No. 5: Please state any problems or potential problems which exist, in your opinion, in the Mode S/ATC system.

Responses:

"When the beacon (transponder) is shut off, the track should not go into coast; it should track (based on) primary (returns)"

"None" - 4 responses

"Reference handoff procedures"

"Data-link instruction would seem to be cumbersome in terminal area, especially on the final vector". (Note: Apparently, the controller refers to transmitting an ATC advisory via a keyboard entry relative to the quicker controller-to-pilot voice communication.)

"System went down too often and took awhile to restart"

"Primary tracking unreliable, tracks ground clutter or drops off"

"No major improvements"

Question No. 6: Do you foresee any potentially serious ATC problems and/or disadvantages which may develop should Mode S/ATC (as configured in today's mission) be implemented in the field?

Responses:

NO - 10 responses

Explanations and Comments:

"Basically same as ARTS except the ability to expand is greater"

"Virgules should be eliminated close to the antenna"

"Tracking primary targets may be problem; didn't know if tracking primary target or ground clutter"

Question No. 7: Does the Mode S/ATC system increase, decrease, or make no difference relative to the workload of the ATC controller?

Responses:

"No difference" - 9 responses
"Minor decrease in workload" - 1 response

Explanations and Comments:

"Due to improved tracking and ability to track the non-beacon aircraft, Mode S is improvement over ARTS III"

Question No. 8: What new ATC procedures, if any, will be needed if Mode S/ATC were implemented in the field?

Responses:

"None" - 9 responses
"Brief controllers on six digit code"

Question No. 9: To what degree do you feel that replacement of today's ARTS III system with Mode S/ATC, as configured in today's mission, would enhance the terminal ATC operations?

Responses:

"Slight difference"
"It enhances because you have an option" (Note: It is not clear what the controller meant by this comment.)
"Possibility exists for interfacility handoff of tower en route traffic" (see above note)
"No major change"
"Better target/data block identification. More reliability"
"No visual difference"

Explanations and Comments:

"The ability to track a primary target would not enhance the system because it is being done today" (Note: Apparently, the controller refers to the ARTS IIIA system in which radar tracking is provided.)

"Mode S would moderately enhance ATC operations"

"If A/C Mode S transponder system is not working he could return to beacon system with his transponder"

"Enhancement is more a part of the hardware of Mode S"

Question No. 10: Do you have any additional comments on the characteristics, implications, and adequacy of the Mode S/ATC system?

Responses:

NO - 7 responses

Explanations and Comments:

"Much less clutter, cleaner scope with single antenna system. However this is no change to the problem of bad radar coverage areas"

Question No. 11: Do you have any suggestions on improvements which should or could be made to Mode S/ATC?

Responses:

NO - 4 responses

"Put Mode S ID symbol in data block"

"Remove auto offset. It is easier to offset manually than it is to read data blocks like these - AL259 BR15"

"Track primary with beacon turned off"

"When an aircraft loses the Mode S beacon, radar track of primary with previous track should last longer. It does flash 'RDR' when it first detects a failure, however it should keep tracking until the controller initiates action to update tag"

SUMMARY OF DEBRIEFING SESSIONS

At the conclusion of each two-day demonstration series, a debriefing meeting was held to review the controllers' comments and observations. The following is a summary of the relevant issues discussed in these meetings.

Debriefing Session of May 19

The following issues were discussed:

- 1) Several times in the demonstration runs, when a datablock was initiated for a Mode S-equipped aircraft, the ATRBS code started blinking as part of the datablock. This appears to be a programming error and should be corrected. (A TATF trouble report was filed.)
- 2) Several controllers stated that they would like to see something in the datablock indicating that the aircraft is Mode S-equipped. Currently, no distinction exists in the datablock display between associated Mode S and ATRBS aircraft. According to the controllers, one instance where such a feature would be useful is during a handoff action, upon transitioning from a system based on a Mode S surveillance to an ATRBS-based system. Of course, when the data-link function becomes available, each Mode S track will have to be clearly identified as such to indicate to the controller which aircraft can receive uplink messages.
- 3) Handoff procedures in Mode S environment need to be developed and evaluated for operational acceptability. Also, interfacility communications (i.e., Mode S/ATRBS and Mode S/Mode S facilities) and intrafacility procedures (i.e., sector to sector) for identifying Mode S-equipped aircraft need to be analyzed and formulated. Future demonstrations should include all of these functions.

- 4) The "1212-decoder" equipment (also referred to as the "ten channel decoder") was not used in the demonstrations. This equipment produces a special indication on the beacon slash to identify controller-selected beacon codes. It is not clear whether or how such a capability will be required or used in the demonstrated system. An investigation should be undertaken to determine whether there exists an operational need to provide 1212-decoder type display on the demonstrated system.
- 5) Procedures need to be developed and evaluated for flight plan filing and processing for Mode S-equipped aircraft. Various operational issues should be clarified: Will the Mode S address be included in the flight plan? Will the bulk store file include Mode S addresses? If so, appropriate means for entering and processing the Mode S address in the flight plans should be developed. If the controller is required to enter the Mode S address, would this increase his workload?
- 6) The quality of the primary radar surveillance is much better than at Philadelphia. The antenna in Philadelphia is at sea-level and the displays contain a lot of ground clutter. There is an area (the northside) where no primary targets are detected. Also, the number of track coasts in the demonstrated system was much less than at Philadelphia.
- 7) When the Mode S transponder is disabled, a new radar track is created but the datablock is not transferred to the new radar track. Thus, no continuity is maintained between the Mode S and radar tracks. This should be corrected.
- 8) One controller noted that the radar display intensity was at a much higher level than usual. This resulted in brighter primary target displays than in Philadelphia, but also caused an increased level of electronic noise on the scope.
- 9) The overall controller display quality in the Video Delay configuration is essentially the same as in today's ARTS III. In the Full Reconstitution configuration, the display is much cleaner since the ground clutter is virtually eliminated.

- 10) The existence of the built-in delay (in both configurations) did not seem to be a problem. In most cases, the controller did not even notice the fact that the sweep lagged behind the digital symbols updates.
- 11) The separation or overlap of the beacon and radar video slashes for radar-reinforced beacon returns is a matter of controller's preference. Some controllers prefer a complete overlap of the two slashes, while others favor a small separation between the slashes so that the radar and beacon returns can be distinguished easily. The radar/beacon slash offset is hardware-adjustable and depends on site practices.
- 12) Some controllers felt that the length of the beacon slash should be reduced, especially at the higher ranges (e.g., 40 nm). It was also noted that, since the controllers separate aircraft based on the ends of the beacon slashes (see Air Traffic Control handbook, FAA 7110.65A, Section 6, Paragraph 721), the length of the slash should be relative to the accuracy of the system; improved accuracy means that shorter slashes would be appropriate. The controllers also noted that the width (thickness) of the slash was acceptable.
- 13) No appreciable weather was displayed in either configuration. Future demonstrations must include weather presentations and evaluations of the adequacy of weather displays in both configurations.
- 14) It was suggested that, in order to reduce the display clutter at the center of the scope, the display of unassociated radar tracks (i.e., virgules) be inhibited up to a prespecified (system parameter) range. The broadband slashes, however, as well as the reconstituted slashes, would continue to be displayed. The operational adequacy of such a capability should be evaluated.
- 15) The implied track drop keyboard entry function should be included in ADS2.

- 16) When a Mode S address was inadvertently used in a keyboard entry for a radar-only track, the message "ILL 3/A" was displayed. This should be corrected to display "ILL Mode S".
- 17) In future demonstrations of the terminal system with Mode S surveillance, several Mode S-equipped aircraft should be used to demonstrate the system performance. These aircraft should exercise a variety of flight maneuvers, e.g., climbs, descents, criss-crossings, turns, etc.
- 18) The left-most display used in the demonstrations needs to be adjusted. Unlike the other displays, no weather clutter was seen on this display in the video delay configuration.
- 19) In future demonstrations, the present ARTS III should run on the other system in the TATF so that a good comparison can be made between that system and the demonstrated system. (This had been planned for this demonstration, but, due to a temporary technical malfunction in the TATF, the ARTS III system could not be operated.)
- 20) The MTI gate in the demonstrated system works in an opposite fashion to that in ARTS III. This should be corrected. Also, unlike ARTS III, the broadband displays are stronger in intensity with the MTI switch on than when the MTI switch is off. The MTI intensity levels should be adjusted.

Debriefing Session of May 21

In the second debriefing session held with the second group of Philadelphia controllers, the following comments and suggestions were made:

- 1) During the demonstration runs, the system failed (aborted) several times. In fact, one of the scheduled runs (i.e., Full Reconstitution on May 20) was cancelled because the Mode S sensor could not be made to function properly. Every time the system failed, it took upward of ten minutes before the run was resumed. Obviously, better reliability of the system must be convincingly demonstrated prior to operational deployment.

- 2) Generally, the controllers concurred that the demonstrated system had better surveillance capability than the ARTS III in Philadelphia. Detection was better, as was tracking over clutter. Also, radar clutter was improved in the demonstrated system.
- 3) One controller questioned whether the improved surveillance in the demonstrated system relative to Philadelphia was due to different terrain characteristics (the land about the Technical Center is mostly flat) or indeed the system is better. No technical analysis has been performed to resolve this issue. One controller stated that, if in fact the improved surveillance is a result of a better radar system, then the demonstrated system indeed provides "very good" surveillance.
- 4) Today, the controller cannot procedurally rely on the altitude display in the datablock. The altitude must be verified on initial contact and during handoff the receiving controller must ask what is the current altitude even if the altitude is displayed in the datablock. Often, the scopes in Philadelphia display unreasonable ("enormous") altitudes (Note: This is probably due to transmission garble). The controllers noted that, if the altitude provided by the Mode S sensor can be relied upon, then the controller's workload would be reduced.
- 5) The general consensus was that the Full Reconstitution configuration was superior to the Video Delay. Full Reconstitution offers "cleaner and neater displays", and also provides a new capability not currently available in ARTS III, namely, tracking of radar-only aircraft.
- 6) The controllers felt that the lengths and widths of the reconstituted slashes were acceptable. It was suggested, however, that the size of the slash be constant over the longer ranges (currently, the length of the slash is a function of the range). But at closer ranges the slash should be short.

- 7) There was disagreement over the effect of false radar tracks displayed in the system. One controller felt that the number of false radar tracks displayed in the demonstrated system was small and would not interfere with controller actions. Another controller, however, "had a hunch" that such tracks would interfere with ATC operations.
- 8) The controllers agreed that tracking of radar-only aircraft is a good feature. One controller noted favorably that the test aircraft used in the run was tracked "all the way to the ground" as a radar-only track.
- 9) Track initiation time in the demonstrated system was much better than that in Philadelphia.
- 10) The controllers did not anticipate any operational or human-factors problems in the introduction of Mode S surveillance in the field. However, one controller indicated that the introduction of data-link might require the controller to "take his eyes off the scope" in order to type in an uplink message and to verify what was typed prior to transmission. This would increase the controller's workload and might also cause an unacceptable time delay for message transmission.
- 11) The controllers did not notice any improved track smoothness (i.e., reduced jitter) due to the increased accuracy of Mode S reports. (Note, however, that the frequency of coasting tracks was reduced in the demonstrated system relative to ARTS III in Philadelphia.)
- 12) One controller noted that he "did not see that much of an improvement" with the Mode S concept. He stated that ATC is performed according to defined procedures, and the airspace is highly sectorized and stratified. Therefore, unique addressing of aircraft does not seem to offer a significant improvement.
- 13) The controllers suggested that, in future demonstrations, the system be shown to controllers from terminal sites known to have good surveillance performance. This would provide a better comparative evaluation of Mode S surveillance against the present ARTS III.

- 14) It was suggested that, in future demonstrations, an ARTS III system be operated alongside the demonstration system in order to facilitate a comparative evaluation of the Mode S system against ARTS III. (Note: This had been planned for the demonstration, but, due to a temporary malfunction in the TATF, the ARTS III system was inoperative during the week of the demonstration.)
- 15) A backup capability should be provided with the demonstrated system to insure continued operations in the event that the Mode S sensor or another subsystem fails. Also, future demonstrations should show how the system will function in the backup mode.
- 16) The controllers stated that it would be preferred that future demonstrations include tests with real aircraft rather than simulated flights.

APPENDIX B

SCHEDULE OF THE DEMONSTRATION ACTIVITIES

SERIES I

May 18, 1981

9:00 to 12:00 : Orientation session and Mode S site
visit.
13:00 : Video Delay run started (without
ARIES)
13:45 : ARIES started
14:45 : Video Delay run completed
15:35 to 16:00 : Full Reconstitution run (with ARIES)

May 19, 1981

9:45 to 10:30 : Full Reconstitution run (with a Mode S
aircraft)
11:00 to 12:00 : Video Delay run (with a Mode S aircraft)
13:00 to 15:00 : Debriefing session

SERIES II

May 20, 1981

9:00 to 12:00 : Orientation session and Mode S site
visit
13:20 to 14:30 : Video Delay run (with ARIES)
15:00 : Full Reconstitution run cancelled due
to an unknown Mode S sensor failure

May 21, 1981

9:15 to 10:35 : Full Reconstitution run (with two
Mode S aircraft)
10:55 to 12:00 : Video Delay run (with two Mode S
aircraft)
13:00 to 15:00 : Debriefing session

APPENDIX C

DEMONSTRATION PARTICIPANTS

SERIES I:

May 18 and May 19

Controllers:

Tom Mooney (PHL)
Donald Reese (PHL)
Don Sullivan (PHL)

Observers:

Steve Devlin (ACT-200)
Haim Gabrieli (MITRE)
Paul Vollmer (ACT-100)

Demonstration Coordinator:

Verne Tallio (ACT-100)

SERIES II:

May 20 and May 21

Controllers:

Ben Calamia (PHL)
Bill McNeil (PHL)
Bill Phillips (PHL)

Observers:

Steve Devlin (ACT-200)
Haim Gabrieli (MITRE)
Paul Vollmer (ACT-100)

Demonstration Coordinator:

Verne Tallio (ACT-100)

APPENDIX D

PHOTOGRAPHS OF CONTROLLERS' SCOPES

This Appendix contains five photographs of the controllers' scopes, four of which include weather presentation. These photographs were taken subsequent to the demonstrations at the FAA Technical Center. No significant weather conditions existed during the demonstrations, and, therefore, weather display could not be evaluated by the controllers. The photographs are as follows:

1. Video Delay Configuration, at time 11:38
2. Video Delay Configuration, at time 11:54
3. Full Reconstitution Configuration, at time 11:28
4. Full Reconstitution Configuration, at time 11:43
5. Full Reconstitution Configuration, at time 10:29

Note that the display in the Video Delay configuration is virtually the same as in today's ARTS III with only minor changes. Mode S-equipped aircraft are not shown. Of special interest is the significant difference of the weather display between the two configurations. Two brightness intensities of weather areas can be seen in the Full Reconstitution displays. A few radar track symbols (/) appear in the Full Reconstitutions photographs mostly near the antenna. Due to the display persistency, some symbols were subject to double exposure. The analog (broadband) beacon and radar slashes cannot be seen in the first four photographs but some slashes are visible in the fifth picture.

FIGURE D-1 EXAMPLE 1 OF CONTROLLER SCOPE IN VIDEO DELAY CONFIGURATION

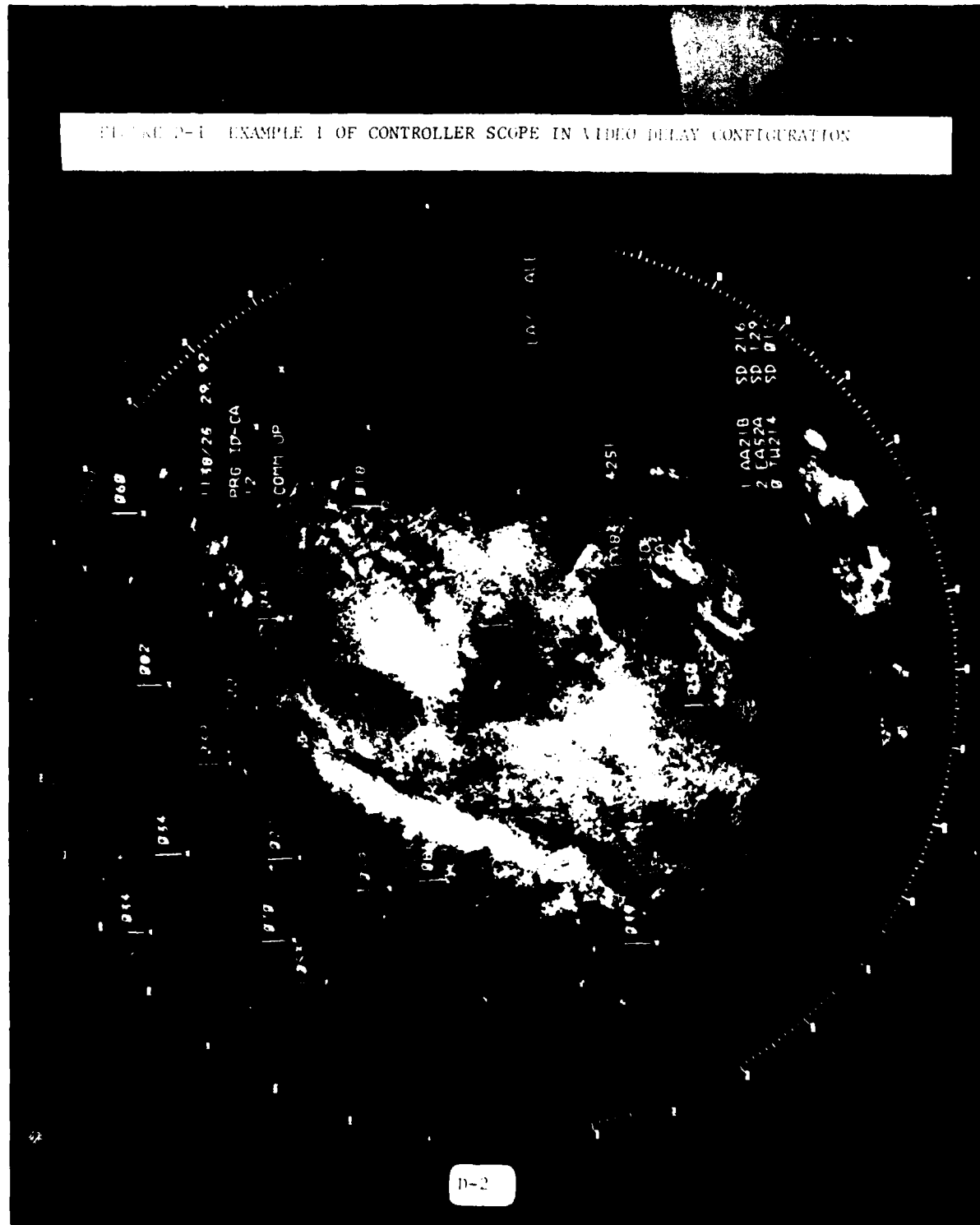

FIGURE D-2 EXAMPLE 2 OF CONTROLLER SCOPE IN VIDEO TELEY CONFERENCE

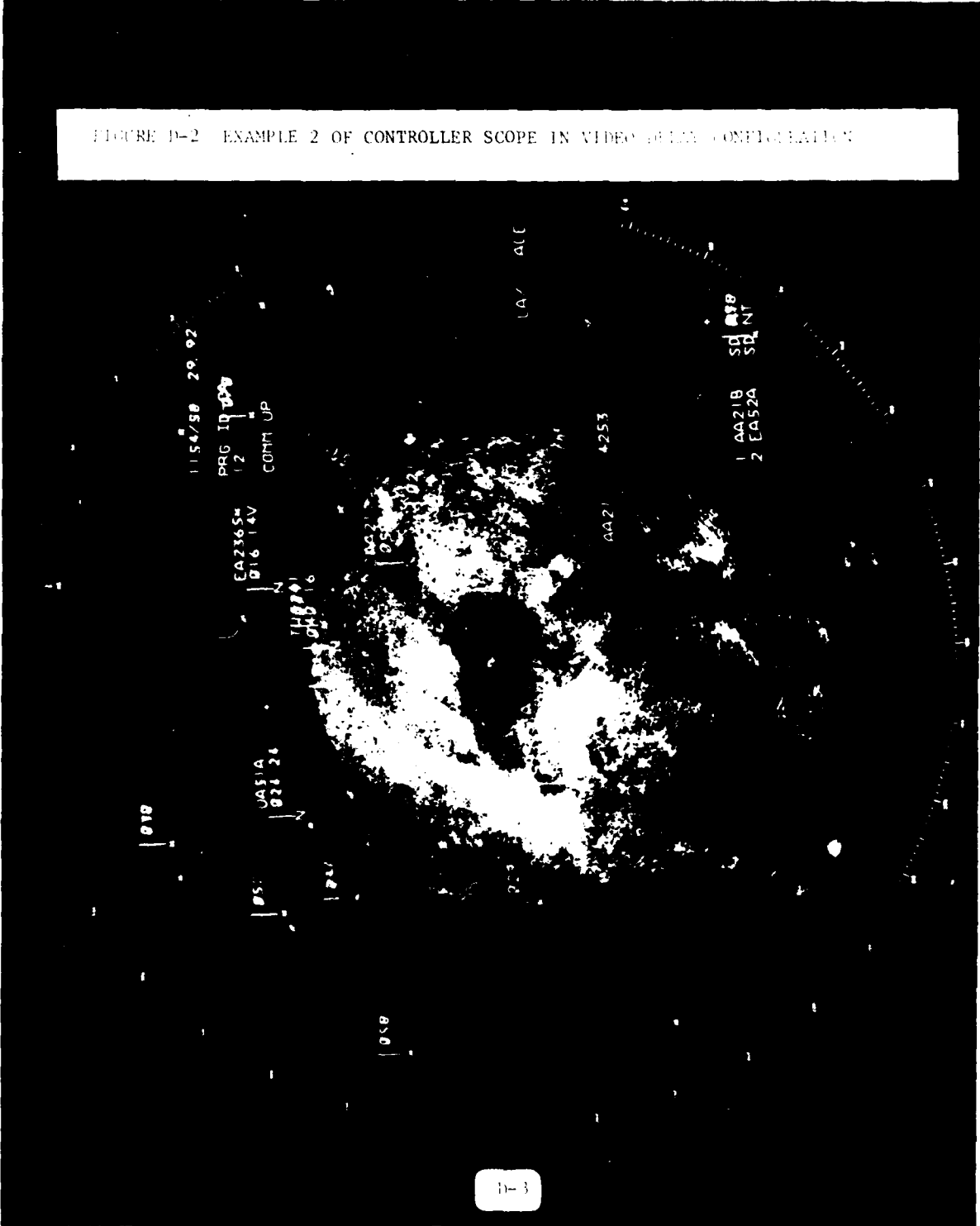
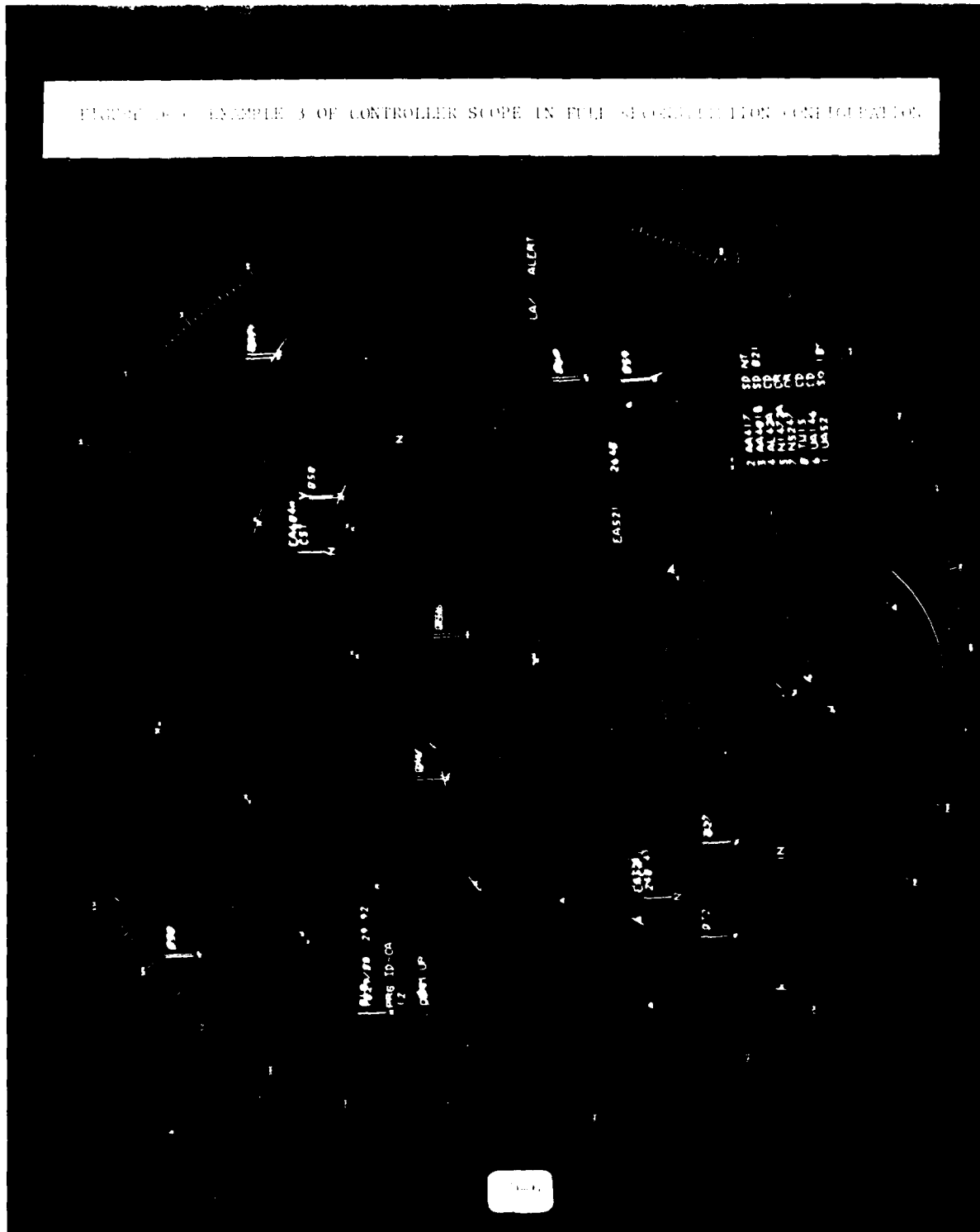

FIGURE 3. EXAMPLE 3 OF CONTROLLER SCOPE IN FULL SELECTION/CONTROL CONFIGURATION.



**DATE
FILMED**

4-8