

AD-A112 700

ARMY ENGINEER WATERWAYS EXPERIMENT STATION VICKSBURG--ETC F/G 13/2
CACHE RIVER PUMPING STATION, SOUTH OF MOUND CITY, ILLINOIS; HYD--ETC(U)
JAN 82 E D ROTHWELL, B P FLETCHER

UNCLASSIFIED

WES/TR/HL-82-1

NL

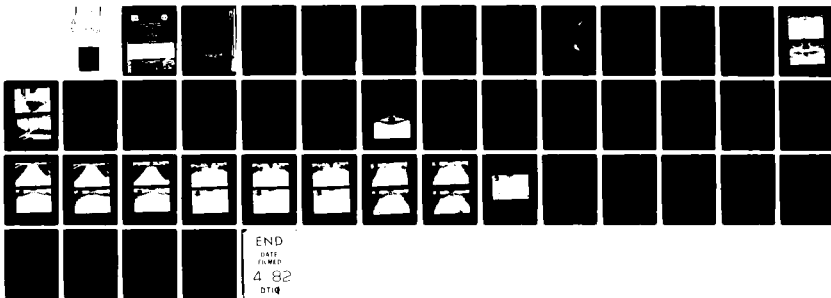

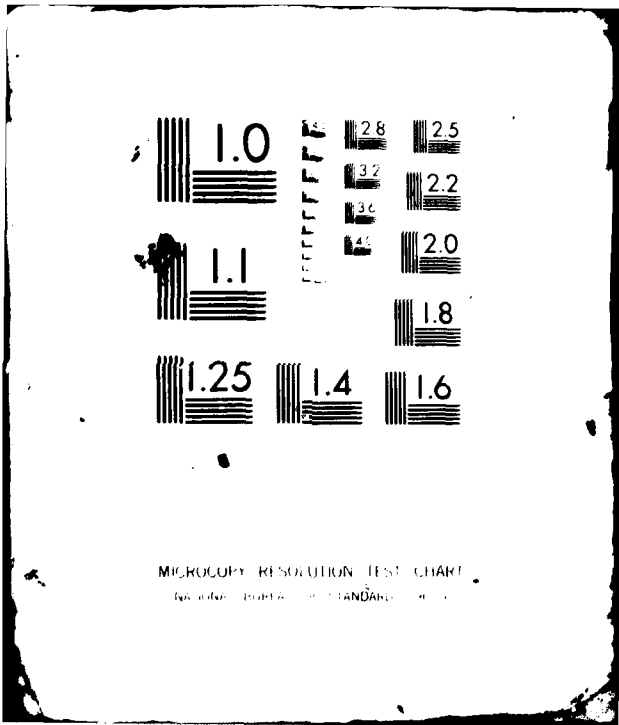

MICROCOPY RESOLUTION TEST CHART
ANSI AND ISO STANDARDS

ADA112700

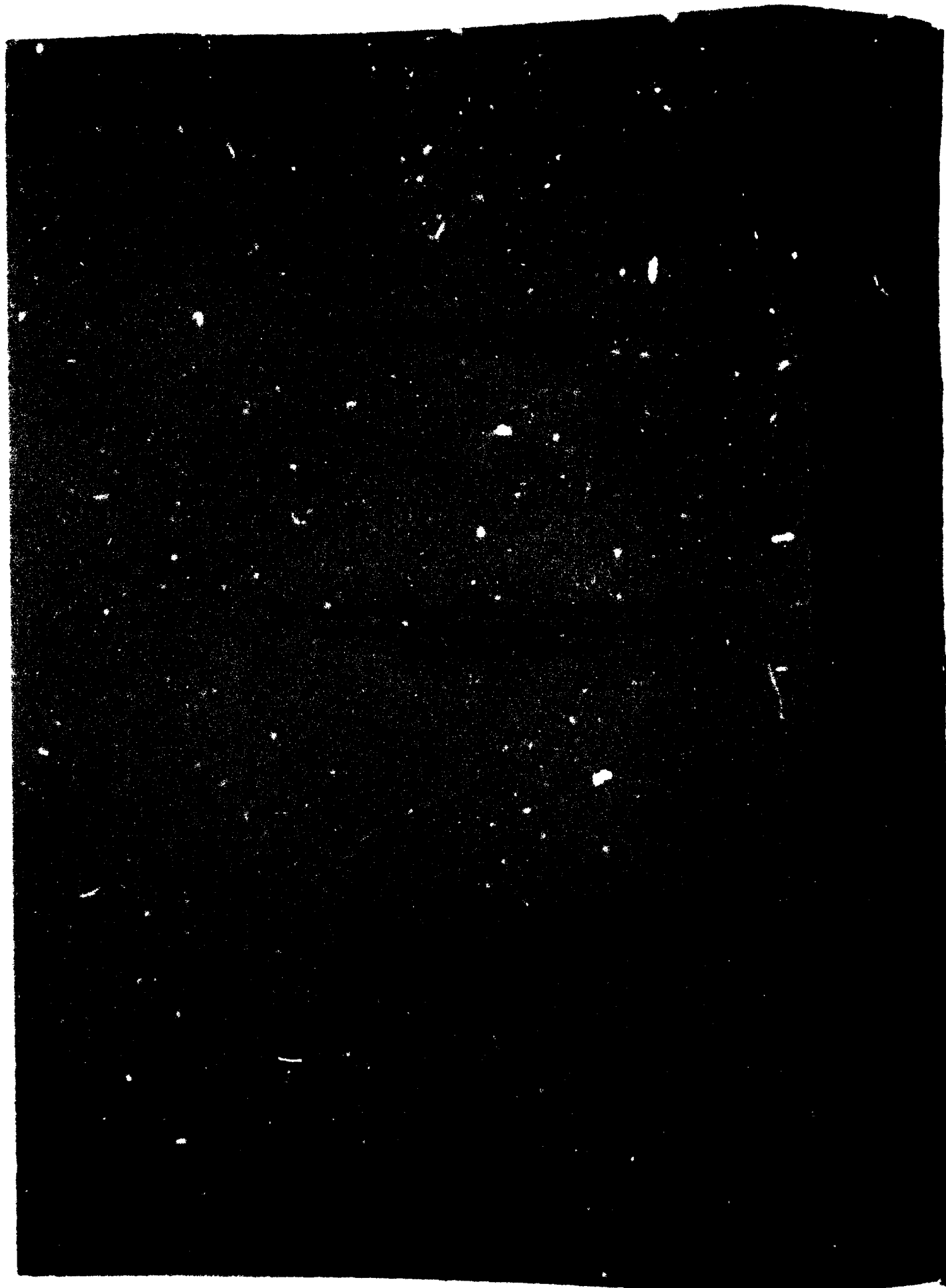

Unclassified

SECURITY CLASSIFICATION OF THIS PAGE (When Data Entered)

REPORT DOCUMENTATION PAGE		READ INSTRUCTIONS BEFORE COMPLETING FORM
1. REPORT NUMBER Technical Report HL-82-1	2. GOVT ACCESSION NO. AD-A112700	3. RECIPIENT'S CATALOG NUMBER
4. TITLE (and Subtitle) CACHE RIVER PUMPING STATION, SOUTH OF MOUND CITY, ILLINOIS; Hydraulic Model Investigation		5. TYPE OF REPORT & PERIOD COVERED Final report
		6. PERFORMING ORG. REPORT NUMBER
7. AUTHOR(s) Edward D. Rothwell Bobby P. Fletcher		8. CONTRACT OR GRANT NUMBER(s)
9. PERFORMING ORGANIZATION NAME AND ADDRESS U. S. Army Engineer Waterways Experiment Station Hydraulics Laboratory P. O. Box 631, Vicksburg, Miss. 39180		10. PROGRAM ELEMENT, PROJECT, TASK AREA & WORK UNIT NUMBERS
11. CONTROLLING OFFICE NAME AND ADDRESS U. S. Army Engineer District, Memphis 668 Clifford Davis Federal Building Memphis, Tenn. 38103		12. REPORT DATE January 1982
		13. NUMBER OF PAGES 39
14. MONITORING AGENCY NAME & ADDRESS (if different from Controlling Office)		15. SECURITY CLASS. (of this report) Unclassified
		15a. DECLASSIFICATION/DOWNGRADING SCHEDULE
16. DISTRIBUTION STATEMENT (of this Report) Approved for public release; distribution unlimited.		
17. DISTRIBUTION STATEMENT (of the abstract entered in Block 20, if different from Report)		
18. SUPPLEMENTARY NOTES Available from National Technical Information Service, 5285 Port Royal Road, Springfield, Va. 22151.		
19. KEY WORDS (Continue on reverse side if necessary and identify by block number) Cache River Pumping Station Hydraulic models Pumping stations Sumps		
20. ABSTRACT (Continue on reverse side if necessary and identify by block number) A 1:10-scale hydraulic model study was conducted to investigate performance of the original design pumping station sump and, if necessary, develop modifications required to provide satisfactory flow to the pump intakes. Satisfactory sump performance was indicated for all anticipated water-surface elevations with either single or multiple pump operations. Adverse sump performance was not evident until the water surface was lowered 3 ft below the minimum anticipated. (Continued)		

DD FORM 1473 EDITION OF 1 NOV 65 IS OBSOLETE

Unclassified
SECURITY CLASSIFICATION OF THIS PAGE (When Data Entered)

Unclassified

SECURITY CLASSIFICATION OF THIS PAGE(When Data Entered)

20. ABSTRACT (Continued).

The model indicated that the approach wing walls to the sump could be constructed of either sheet piling or concrete as originally designed.

The size and extent of approach channel riprap protection required for stability with all anticipated flow conditions were also determined.

Unclassified

SECURITY CLASSIFICATION OF THIS PAGE(When Data Entered)

PREFACE

The model investigation reported herein was authorized by the Office, Chief of Engineers (OCE), U. S. Army, on 12 May 1976, at the request of the U. S. Army Engineer District, Memphis.

The study was conducted intermittently during the period May 1976 to July 1979 in the Hydraulics Laboratory of the U. S. Army Engineer Waterways Experiment Station (WES) under the direction of Messrs. H. B. Simmons, Chief of the Hydraulics Laboratory, and J. L. Grace, Jr., Chief of the Hydraulic Structures Division, and under the direct supervision of Mr. N. R. Oswalt, Chief of the Spillways and Channels Branch. The project engineers for the model study were Messrs. E. D. Rothwell and B. P. Fletcher, assisted by Messrs. R. L. Bryant and E. Jefferson. This report was prepared by Messrs. Rothwell and Fletcher.

During the course of the investigation, Messrs. H. Wardlaw and C. Thomas of the Memphis District visited WES to observe the model in operation and discuss results of model tests.

Commanders and Directors of WES during the conduct of the study and the preparation and publication of this report were COL G. H. Hilt, CE, COL John L. Cannon, CE, COL Nelson P. Conover, CE, and COL Tilford C. Creel, CE. Technical Director was Mr. F. R. Brown.

Accession For	
NTIS GRA&I	<input checked="" type="checkbox"/>
DTIC TAB	<input type="checkbox"/>
Unannounced	<input type="checkbox"/>
Justification	
By _____	
Distribution/	
Availability Codes	
Dist	Avail and/or Special
A	

DTIC
COPY
INSPECTED
2

CONTENTS

	<u>Page</u>
PREFACE	1
CONVERSION FACTORS, U. S. CUSTOMARY TO METRIC (SI)	
UNITS OF MEASUREMENT	3
PART I: INTRODUCTION	5
The Prototype	5
Purpose of Model Study	5
PART II: THE MODEL	7
Description	7
Interpretation of Results	7
PART III: TESTS AND RESULTS	11
Sump Performance	11
Approach Wing Walls	14
Stone Protection (Approach Channel)	16
PART IV: SUMMARY	17
TABLES 1-3	
PHOTOS 1-11	
PLATES 1-8	

CONVERSION FACTORS, U. S. CUSTOMARY TO METRIC (SI)
UNITS OF MEASUREMENT

U. S. customary units of measurement used in this report can be converted to metric (SI) units as follows:

<u>Multiply</u>	<u>By</u>	<u>To Obtain</u>
acres	4046.856	square metres
cubic feet per second	0.02831685	cubic metres per second
feet	0.3048	metres
feet per second	0.3048	metres per second
gallons (U. S. liquid) per minute	3.785412	cubic decimetres per minute
inches	25.4	millimetres
miles (U. S. statute)	1.609344	kilometres
pounds (force) per square inch	6894.757	pascals
pounds (mass)	0.4535924	kilograms
square miles (U. S. statute)	2.589988	square kilometres

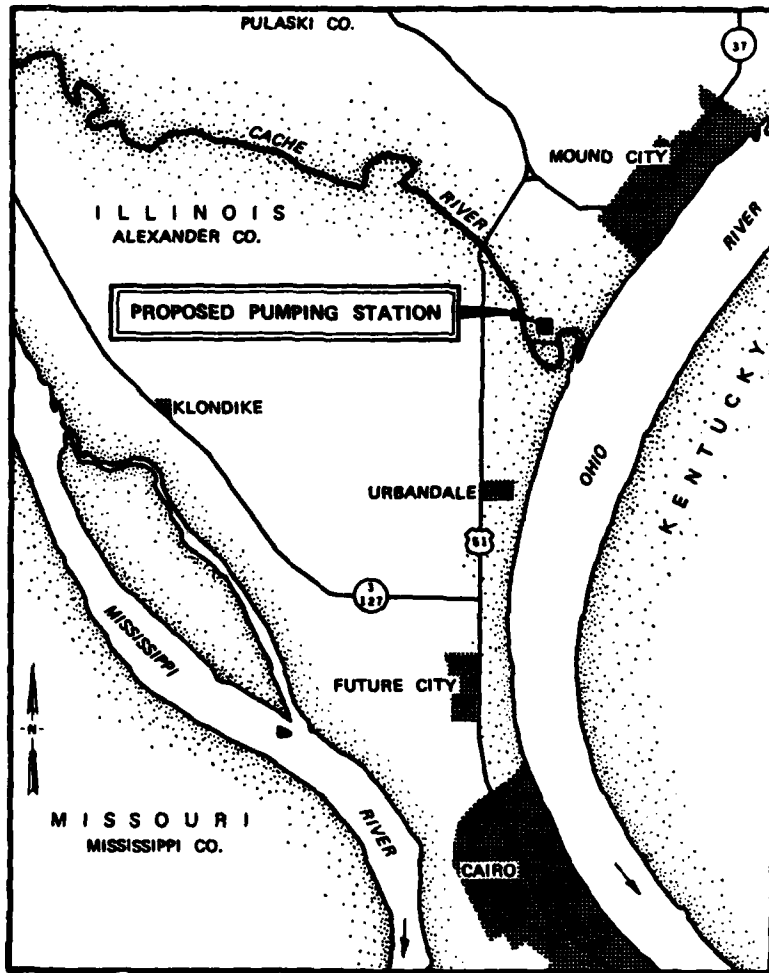

Figure 1. Location map

CACHE RIVER PUMPING STATION
SOUTH OF MOUND CITY, ILLINOIS
Hydraulic Model Investigation

PART I: INTRODUCTION

The Prototype

1. Cache River pumping station will be located south of Mound City, in Pulaski County, Illinois, between the confluence of the Mississippi and Ohio Rivers. The area will be bounded on the south by the Cache River, on the east by the Ohio River, and on the north and west by levees along the Mississippi River (Figure 1). The pumping station drainage area consists of about 7,730 acres* (12.08 square miles). The general plan, model limits, and details of the original design pumping station are shown in Plates 1-4.

2. The proposed pumping station will be of the wet-pit (sump) type and will employ three vertical-shaft, mixed-flow-type pumps to provide a pumping capacity of 89,760 gpm. Trashracks will be provided for protection of the pump intakes from debris. The pump intakes, at el 298.5,** will be separated by divider walls extending the length of the station. The floor slabs of the pump bays and approach channel are at el 297.0. The proposed design has incorporated two approach wing walls which extend upstream approximately 52 ft at an angle of 45 deg from the pumping station. The pumps will discharge through three 36-in.-diam discharge pipes constructed over the existing levee.

Purpose of Model Study

3. The model study was conducted to evaluate the characteristics

* A table of factors for converting U. S. customary units of measurement to metric (SI) units is presented on page 3.

** All elevations (el) cited herein are in feet referred to the National Geodetic Vertical Datum (NGVD).

of inflow to the original sump and to develop modifications, if necessary, for improving the flow distribution to the pump intakes. In addition, the model was used to determine the upstream riprap protection and alternate approach wing wall design.

PART II: THE MODEL

Description

4. The model of Cache River pumping station (Figure 2a), constructed to an undistorted linear scale ratio of 1:10, reproduced approximately 600 ft of the approach channel, the detailed geometry of the upstream approach wing walls (Figure 2b), and the pumping station. The proposed pumping station (Figure 3), which consists of the sump chamber and three pump intakes, was fabricated of transparent plastic to permit visual observation of flow approaching and entering the pump intakes. Flow through each pump intake was provided by individual suction pumps that permitted simulation of various flow rates through one or more pump intakes. Trashracks were simulated with metal strips forming a mesh screen. Access ladders were formed from brass rods.

5. Water used in the model was stored and recycled through a concrete sump and centrifugal pump and piping system. Discharges were measured by turbine flowmeters. Water-surface elevations were measured by staff and point gages. Velocities were measured by timing the linear displacement of dye injected into the water and confetti sprinkled on the water surface. Pressure fluctuations at the pump intakes were measured with 15-psia electronic pressure cells installed flush with the sump floor directly below the center line of the pump column and were recorded on an oscillograph. Rotational characteristics of the flow entering the suction bell intakes were measured by vortimeters (free rotating propellers with zero-pitch blades) located inside each pump intake at the approximate position of the prototype pump propeller. Locations of the pressure cell and vortimeter are shown in Figure 4.

Interpretation of Results

6. The predominant forces affecting flows in the approach channel and pump chambers are inertia and gravity. Under these conditions, hydraulic similarity between model and prototype requires that the ratio

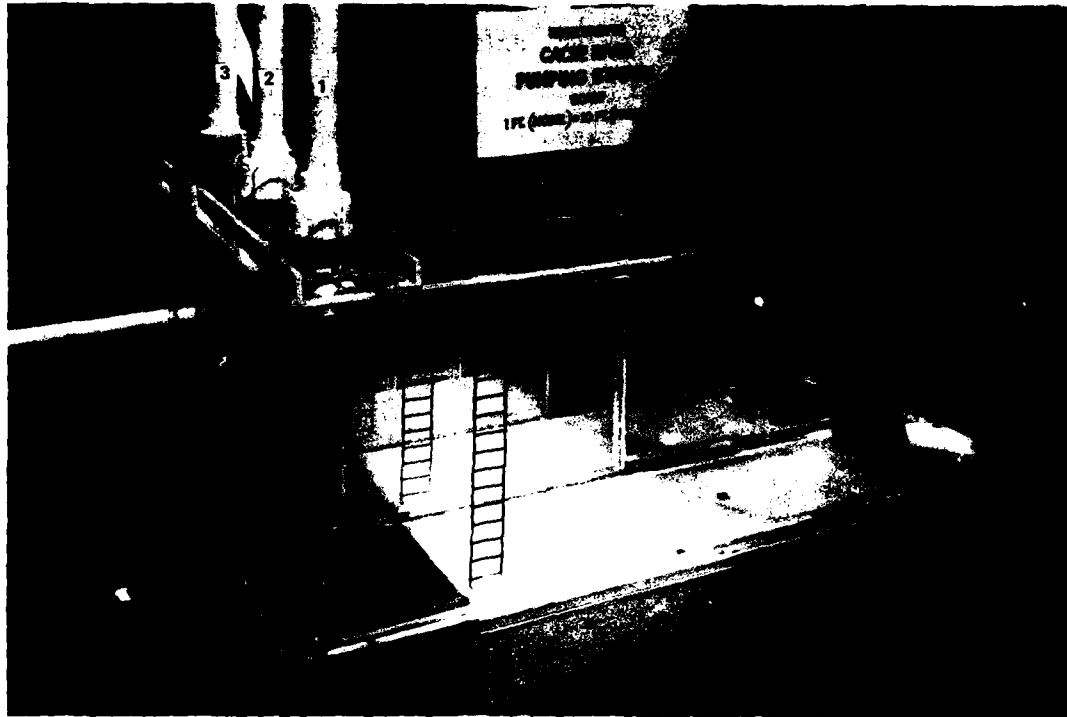

Figure 3. Model of original design pumping station

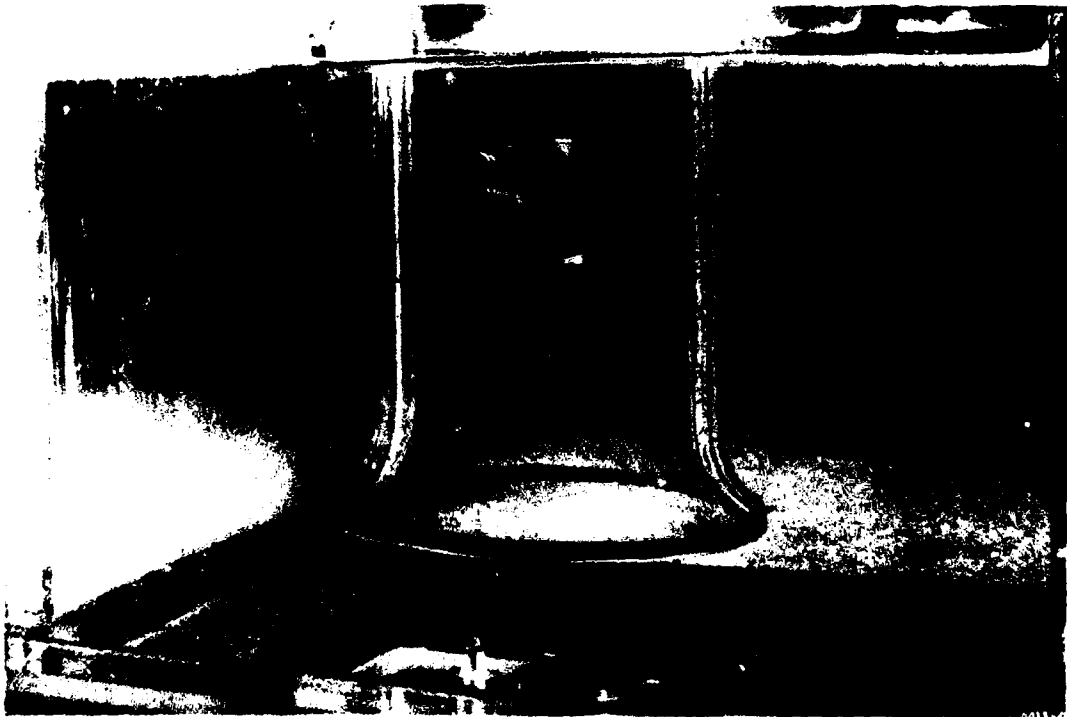

Figure 4. Flow conditions, original design; pump 3 operating, water-surface el 301 (5 ft below minimum sump)

of inertial to gravitational forces, defined as the Froude number of flow, be identical in both model and prototype. Therefore, the accepted equations of hydraulic similitude, based upon the Froudian criteria, were used to express the mathematical relationships between the dimensions and hydraulic quantities of the model and the prototype. The general relations are as follows:

<u>Dimension</u>	<u>Ratio</u>	<u>Scale Relation</u>
Length	L_r	1:10
Area	$A_r = L_r^2$	1:100
Velocity	$V_r = L_r^{1/2}$	1:3.16
Discharge	$Q_r = L_r^{5/2}$	1:316.23
Time	$T_r = L_r^{1/2}$	1:3.16
Pressure	$P_r = L_r$	1:10
Frequency	$f_r = \frac{1}{L_r^{1/2}}$	1:0.316

Measurement of discharge, water-surface elevations, heads, velocities, pressure, and frequency can be transferred quantitatively from model to prototype equivalents by these scale relations.

PART III: TESTS AND RESULTS

Sump Performance

Original design

7. The 1:10-scale reproduction of the original design of the pump sump including the three 36-in.-diam pump intakes, pumps numbered as indicated, is presented in Figure 3. The pumps will operate within the range of the minimum sump water-surface elevation of 306.0 and the maximum sump water-surface elevation of 313.7 at a capacity of 200 cfs. Hydraulic performance of the pump sump was evaluated by visual observations of flow conditions and measurements of velocities and flow distributions, pressure fluctuations on the floor of the sump directly below the vertical axis of the pump column, and rotational flow tendencies (swirl).

8. Pressure fluctuations (expressed as feet of water) and rotational flow tendencies (expressed as revolutions per minute in the prototype intakes) measured with the type 1 (original) design sump are presented in Table 1. Details of the type 1 (original) design and type 2 design pump intakes are presented in Figure 5. The type 2 design pump intake consisted of increasing the distance between the floor (el 297.0) and the suction bell to 3.6 ft or 0.8 of the diameter of the suction bell; results of the type 2 design pump intake are presented in Table 2. Results of these sump performance tests indicate that satisfactory flow distribution would be provided with either of the pump intakes. No significant difference in hydraulic performance was apparent with the suction bell located 0.33 and 0.80 of the diameter of the suction bell above the floor of the sump. The pressure fluctuations and swirl observed showed essentially no instability or rotation of flow in the vicinity of the intakes with the anticipated water-surface elevations of 306.0, 309.9, and 313.7. Flow patterns in the approach channel observed with a 10-sec (prototype) time exposure and the type 1 (original) design sump are presented in Photos 1-6 for various combinations of pumping operations. Surface currents are depicted by confetti floating on the surface during a 10-sec (prototype) time exposure.

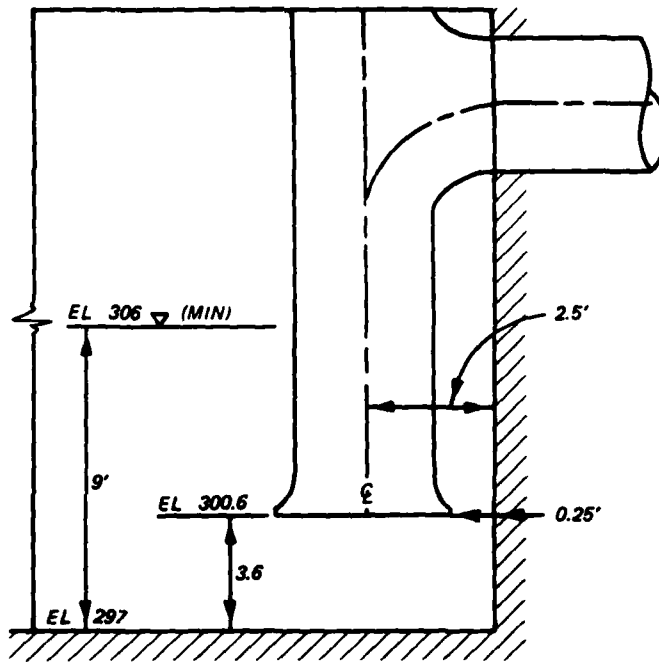

TYPE 2 DESIGN

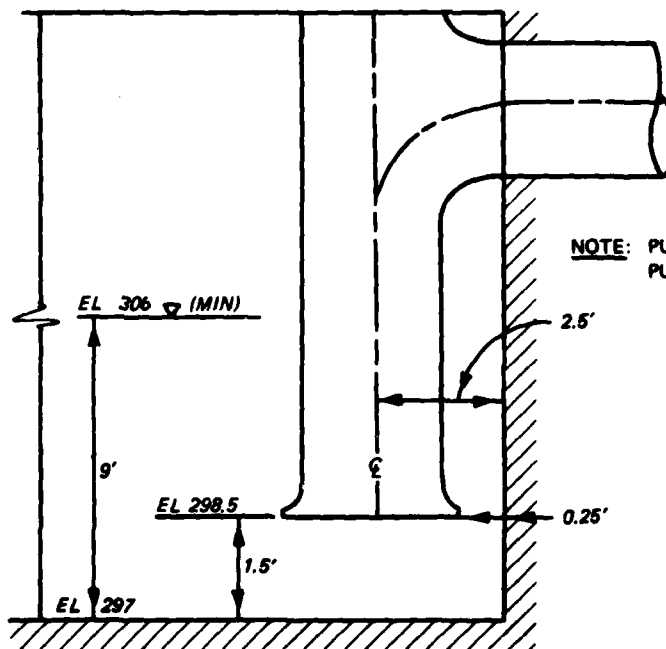

NOTE: PUMP COLUMN DIAMETER = 3.0'
PUMP BELL-MOUTH DIAMETER = 4.5'

ORIGINAL TYPE 1 DESIGN

Figure 5. Details of type 1 (original) and type 2 design pump intakes

9. Additional tests were conducted with the type 1 (original) design sump to identify the water-surface elevation below which unsatisfactory flow conditions at the pump intakes would result. Results of these tests are presented below:

Water-Surface El ft NGVD	Sump Performance Indicator	Pump		
		1	2	3
305.1	Pressure fluctuation, ft	1.5	1.3	1.3
	Swirl, rpm	1.9→	0.4→	0.6→
	Stage of vortex	--	--	--
304.0	Pressure fluctuation, ft	1.6	1.3	1.3
	Swirl, rpm	1.6→	0.3→	0.2→
	Stage of vortex	A	A	A
302.5	Pressure fluctuation, ft	2.0	1.3	1.4
	Swirl, rpm	2.5→	1.9→	0.1→
	Stage of vortex	B	B	A
302.0	Pressure fluctuation, ft	2.0	1.3	1.3
	Swirl, rpm	2.5→	3.8→	0.6→
	Stage of vortex	C	B	A
301.5	Pressure fluctuation, ft	2.5	1.0	1.3
	Swirl, rpm	4.4→	1.9→	0.6→
	Stage of vortex	C	B	B
301.0	Pressure fluctuation, ft	2.6	1.0	1.5
	Swirl, rpm	4.4→	3.2→	1.3→
	Stage of vortex	D	C	B

Note: → = clockwise rotation.

Air-entraining vortices (Figure 4) occurred intermittently at the pump intake with water-surface el 301.0, which is 5 ft below the minimum water-surface el 306.0. Figure 6 shows the stages in the development of an air-entraining vortex from a small depression (A) in the water surface which gradually becomes deeper until air bubbles intermittently break away, forming a continuous air core extending into the pump intake (E). The stages of a vortex discussed above and illustrated below were used to define the flow conditions observed in the model.

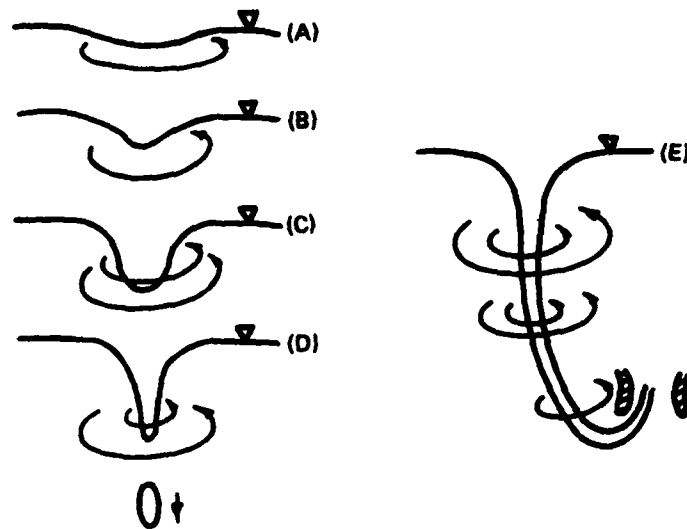
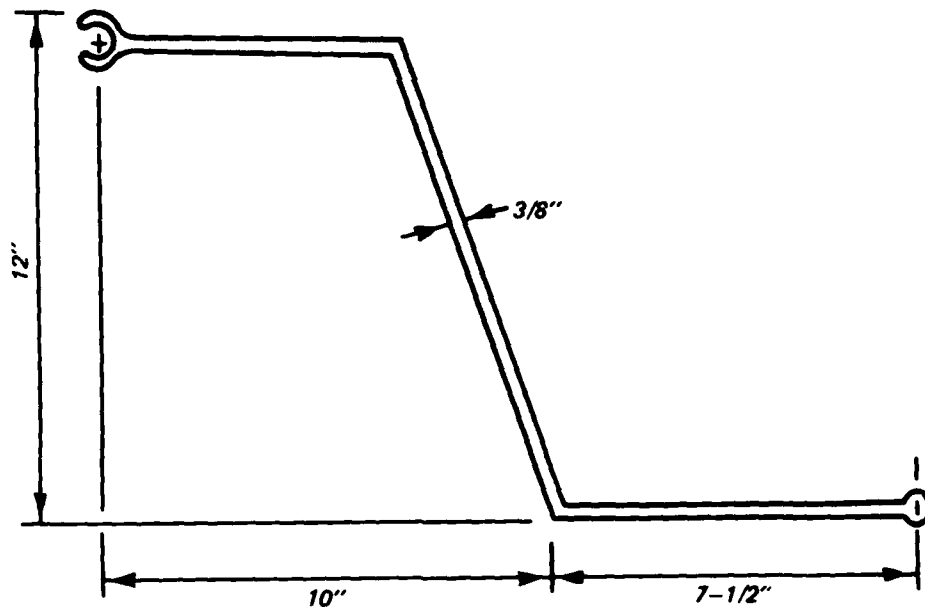

Figure 6. Stages in development of air-entraining vortex

Approach Wing Walls

10. The type 1 (original) design approach wing walls (Plate 2 and Figure 2b) consisted of reinforced concrete. For reasons of economy, engineers of the U. S. Army Engineer District, Memphis, requested additional tests to evaluate the hydraulic feasibility of using sheet piling wing walls (type 2 design) in lieu of the original design.

11. The geometric shape of the proposed PZ-27 sheet piling (Figure 7) used for the type 2 wing walls was simulated in the model as shown in Figure 8. Location and height of the type 2 wing walls were identical to the original type 1 wing walls. Observations of flow conditions with the type 2 wing walls for various combinations of pumps (type 1 intake design) operating at various sump elevations indicated that small-scale turbulence generated at the offsets in the sheet piling did not significantly affect the flow distribution or hydraulic performance of the sump. Approach channel flow patterns for various combinations of operating conditions obtained with a 50-sec (prototype) time exposure are shown in Photos 7-11. The type 2 wing walls tended



PLAN

Figure 7. Typical sheet piling section (PZ-27) section for type 2 wing walls

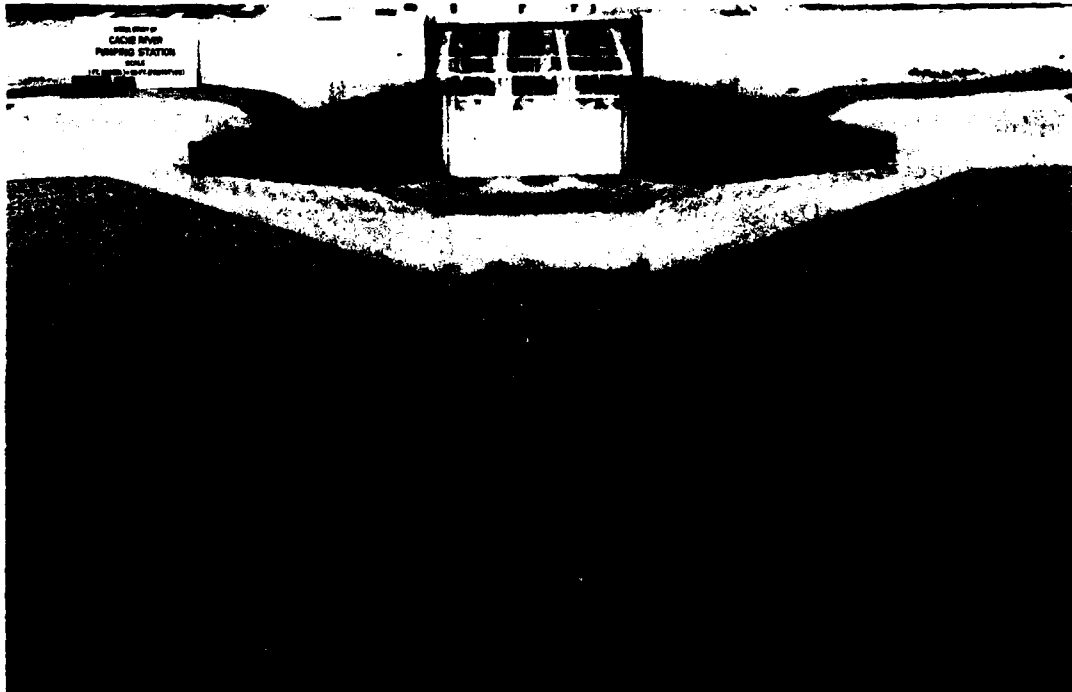

Figure 8. Sheet piling approach wing walls (type 2)

to concentrate flow in the center of the approach as shown in Photo 10 compared with Photo 3; however, sump performance was not adversely affected. Pressure fluctuations and swirl measured at the pump intakes are presented in Table 3 and are similar to those obtained with the type 1 (original) design sump in Table 1. An analysis of these data indicates that satisfactory sump performance can be expected with either the type 2 sheet piling or the type 1 (original) concrete wing walls.

Stone Protection (Approach Channel)

12. Tests were conducted in the 1:10-scale model to evaluate the proposed approach riprap protection plan. The type 1 (original) riprap protection (Plate 2) consisted of a 20-ft length of riprap, with a maximum stone weight of 691 lb ($d_{100} = 24$ in.).

13. Velocities measured with the minimum anticipated water-surface elevation (el 306.0) for various combinations of pumping operations are presented in Plates 5-7. These velocities (prototype) were measured 1 ft above the approach channel and floor of the sump. Based on these velocity measurements and visual observations of flow with sand in the approach (Figure 8), a 20-ft length of minimum riprap gradation having a 12-in. thickness with a maximum stone weight of 86 lb* (type 2 riprap protection) will remain stable under all anticipated pumping operations. Details of the type 2 riprap protection plan are presented in Plate 8.

* Office, Chief of Engineers. ETL-110-2-120, 4 May 1971, "Additional Guidance for Riprap Channel Protection."

PART IV: SUMMARY

14. Hydraulic performance of the pump sump was evaluated by visual observations of flow conditions and measurements of flow distributions, pressure fluctuations, and swirl. An analysis of these results indicates that satisfactory sump performance would be provided with either the type 1 (original) or the type 2 pump intakes. There was no apparent significant difference in hydraulic performance with the suction bell located 0.33 and 0.80 of the diameter of the suction bell above the floor of the sump.

15. Additional tests were conducted to evaluate the hydraulic feasibility of using sheet piling (PZ-27) wing walls (type 2 design) in lieu of the original concrete wing walls (type 1 design). Model results indicate that satisfactory sump performance can be achieved with either the type 2 sheet piling or the type 1 (original) concrete wing walls.

16. Based upon an analysis of velocities and visual observations of approach flow conditions, the minimum riprap gradation with a 12-in. thickness and a maximum stone weight of 86 lb* (type 2 riprap protection) was considered adequate to ensure stability of the approach for all anticipated pumping conditions.

* See footnote on page 16.

Table 1
Sump Performance, Type 1 (Original) Design

Water-Surface El ft NGVD	Sump Performance Indicator	Pump No.		
		1	2	3
306.0	Pressure fluctuation*	1.3	X	X
	Rotational flow tendency, rpm**	0.6→		
306.0	Pressure fluctuation	1.2	1.4	X
	Rotational flow tendency	1.3→	0.6→	
306.0	Pressure fluctuation	1.3	1.4	1.0
	Rotational flow tendency	0.9→	0.3→	0.6→
306.0	Pressure fluctuation	X	1.0	X
	Rotational flow tendency		0.1→	
306.0	Pressure fluctuation	1.3	X	0.8
	Rotational flow tendency	0.6←		1.3→
306.0	Pressure fluctuation	X	X	0.7
	Rotational flow tendency			0.5→
309.9	Pressure fluctuation	0.9	X	X
	Rotational flow tendency	1.9→		
309.9	Pressure fluctuation	1.0	1.3	X
	Rotational flow tendency	1.3→	0.6←	
309.9	Pressure fluctuation	1.0	1.2	1.1
	Rotational flow tendency	1.9→	0.6→	0.2→
309.9	Pressure fluctuation	X	1.3	X
	Rotational flow tendency		0.6→	
309.9	Pressure fluctuation	1.0	X	0.9
	Rotational flow tendency	1.9→		0.6→

(Continued)

Note: All magnitudes are expressed in terms of prototype equivalents.
 → = clockwise rotation; ← = counterclockwise rotation; X = pump not operating.

* Pressure fluctuation is in feet of water.

** rpm is revolutions per minute and is a measure of swirl. Discharge per pump 66.7 cfs or 29,920 gpm.

Table 1 (Concluded)

Water-Surface El ft NGVD	Sump Performance Indicator	Pump No.		
		1	2	3
309.9	Pressure fluctuation	X	X	0.9
	Rotational flow tendency			1.3→
313.7	Pressure fluctuation	1.25	X	X
	Rotational flow tendency	1.9→		
313.7	Pressure fluctuation	1.5	0.8	X
	Rotational flow tendency	2.2→	0.2←	
313.7	Pressure fluctuation	1.75	0.7	1.0
	Rotational flow tendency	1.9→	0.6→	0.2←
313.7	Pressure fluctuation	X	0.5	X
	Rotational flow tendency		0.6←	1.3→
313.7	Pressure fluctuation	X	X	0.9
	Rotational flow tendency			1.3→

Table 2
Sump Performance, Type 2 Design Pump Intake

Water-Surface El ft NGVD	Sump Performance Indicator	Pump No.		
		1	2	3
306.0	Pressure fluctuation*	1.0	X	X
	Rotational flow tendency, rpm**	1.6→		
306.0	Pressure fluctuation	1.25	1.0	X
	Rotational flow tendency	1.9→	0.9→	
306.0	Pressure fluctuation	1.0	1.0	1.25
	Rotational flow tendency	2.2→	0.6→	0.5→
306.0	Pressure fluctuation	X	0.9	X
	Rotational flow tendency		0.9→	
306.0	Pressure fluctuation	1.0	X	1.0
	Rotational flow tendency	0.6→		1.9→
306.0	Pressure fluctuation	X	X	0.5
	Rotational flow tendency			1.3→
309.9	Pressure fluctuation	0.5	X	X
	Rotational flow tendency	0.6→		
309.9	Pressure fluctuation	1.9	1.0	X
	Rotational flow tendency	2.2→	0.3→	
309.9	Pressure fluctuation	1.5	1.0	1.25
	Rotational flow tendency	1.9→	0.6→	0.3→
309.9	Pressure fluctuation	X	0.55	X
	Rotational flow tendency		0.1→	
309.9	Pressure fluctuation	0.63	X	0.75
	Rotational flow tendency	0.6→		0.6→

(Continued)

Note: All magnitudes are expressed in terms of prototype equivalents.

→ = clockwise rotation; X = pump not operating.

* Pressure fluctuation is in feet of water.

** rpm is revolutions per minute and is a measure of swirl. Discharge per pump 66.7 cfs or 29,920 gpm.

Table 2 (Concluded)

Water-Surface El ft NGVD	Sump Performance Indicator	Pump No.		
		1	2	3
309.9	Pressure fluctuation	X	X	0.75
	Rotational flow tendency			0.9→
313.7	Pressure fluctuation	1.0	X	X
	Rotational flow tendency	0.2→		
313.7	Pressure fluctuation	1.3	1.00	X
	Rotational flow tendency	0.3→	0.1→	
313.7	Pressure fluctuation	1.2	1.0	1.25
	Rotational flow tendency	0.9→	0.3→	0.6→
313.7	Pressure fluctuation	X	0.75	X
	Rotational flow tendency		0.1→	
313.7	Pressure fluctuation	1.0	X	0.75
	Rotational flow tendency	0.6→		0.6→
313.7	Pressure fluctuation	X	X	0.75
	Rotational flow tendency			0.6→

Table 3
Sump Performance with Type 2 Wing Walls
Type 2 Intake Design

Water- Surface El ft NGVD	Sump Performance Indicator	Pump No.		
		1	2	3
306.0	Pressure fluctuation*	1.1	X	X
	Rotational flow tendency, rpm**	0.5→		
306.0	Pressure fluctuation	1.0	1.4	X
	Rotational flow tendency	0.9→	0.8→	
306.0	Pressure fluctuation	1.4	1.5	1.3
	Rotational flow tendency	0.7→	0.6→	0.6→
306.0	Pressure fluctuation	1.2	X	1.2
	Rotational flow tendency	0.6←		1.0→
313.7	Pressure fluctuation	1.6	0.8	0.9
	Rotational flow tendency	1.4→	0.6→	0.5→

Note: All magnitudes are expressed in terms of prototype equivalents.
→ = clockwise rotation; ← = counterclockwise rotation; X = pump not operating.

* Pressure fluctuation is in feet of water.

** rpm is revolutions per minute and is a measure of swirl. Discharge per pump 66.7 cfs or 29,920 gpm.

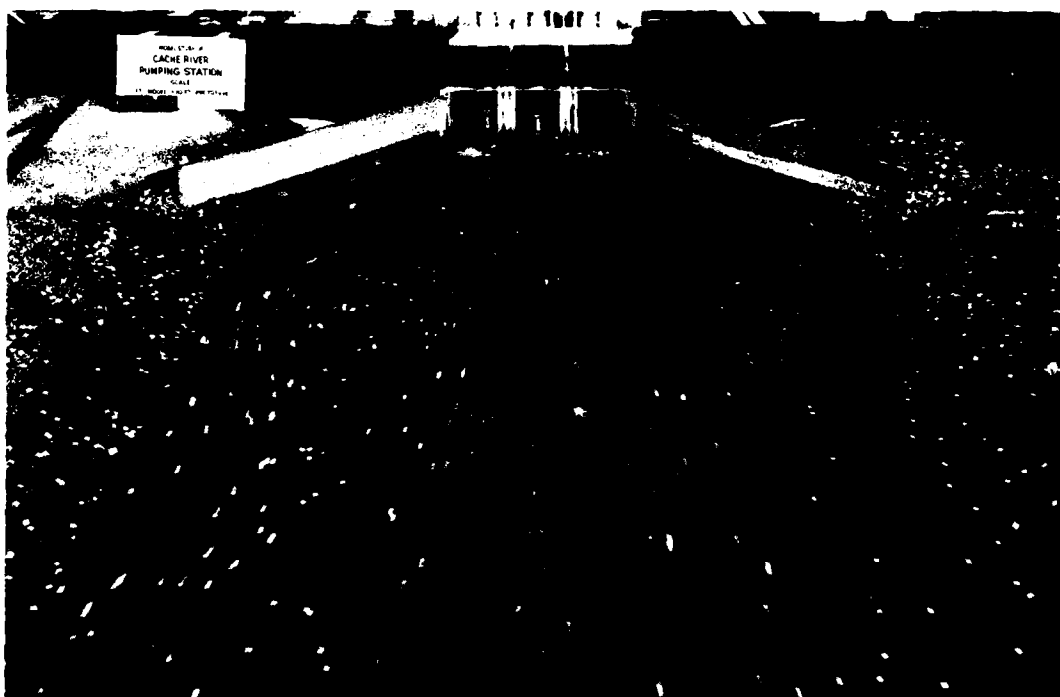

Photo 1. Flow patterns in approach channel, type 1 (original) design; water-surface el 306.0, pump 3 operating, 10-sec (prototype) exposure

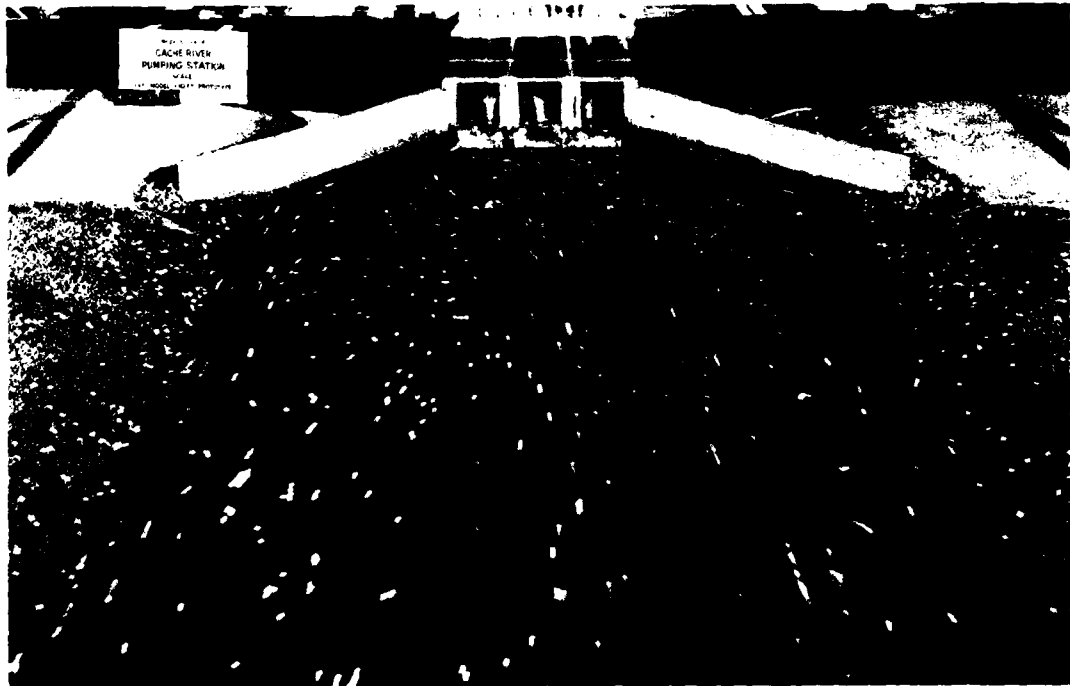

Photo 2. Flow patterns in approach channel, type 1 (original) design; water-surface el 306.0, pumps 1 and 3 operating, 10-sec (prototype) exposure

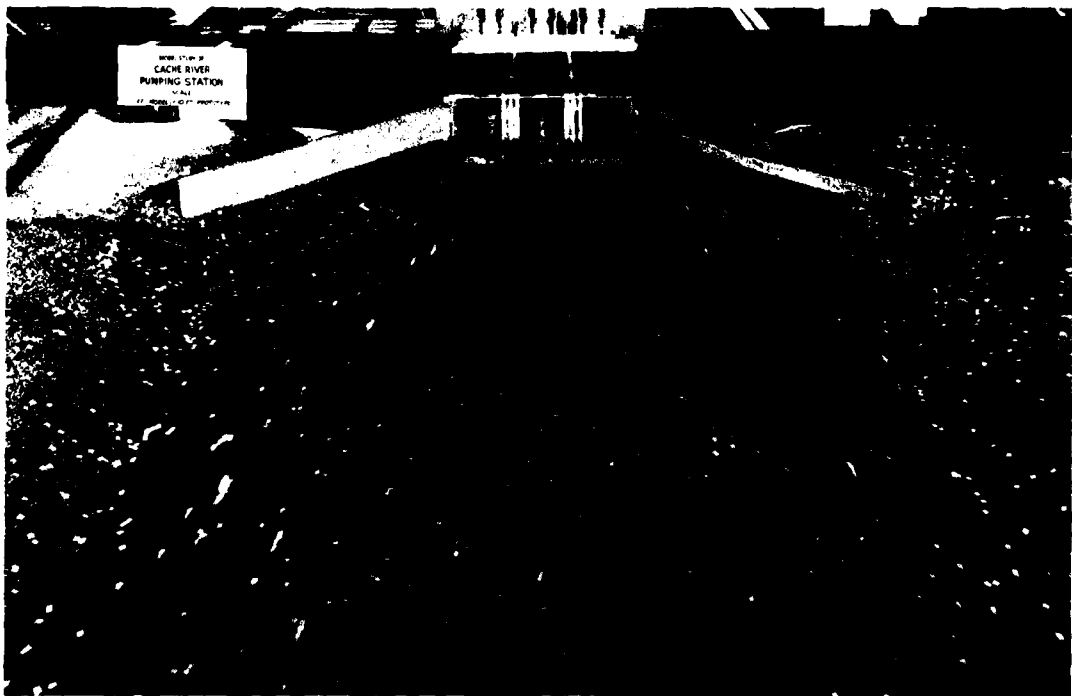
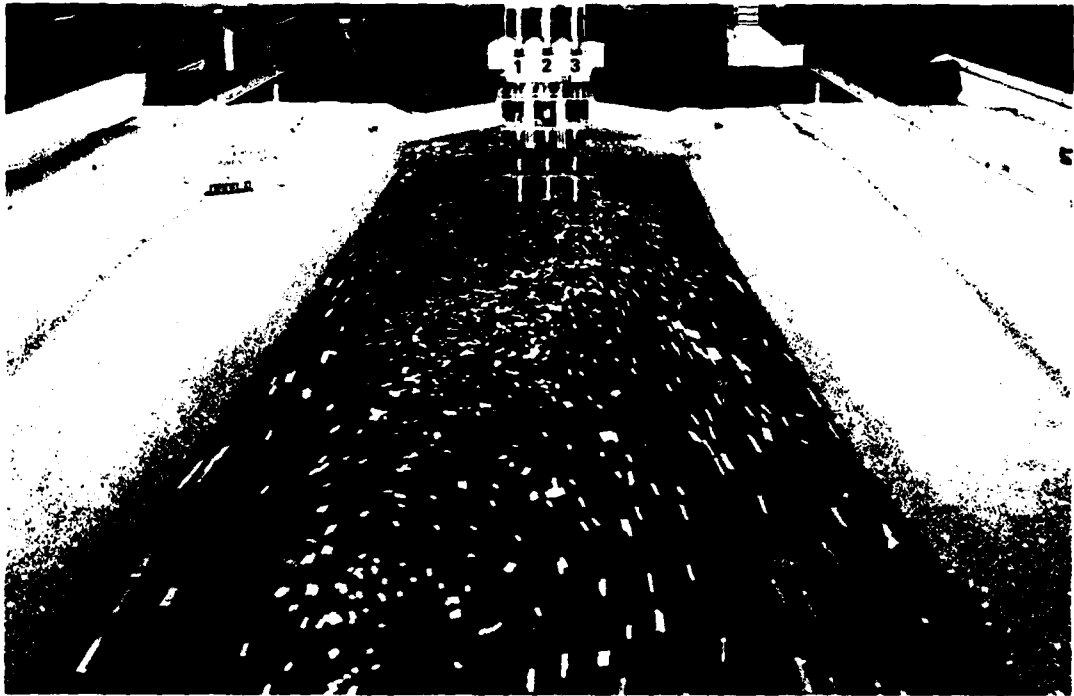

Photo 3. Flow patterns in approach channel, type 1 (original) design; water-surface el 306.0, pumps 1, 2, and 3 operating, 10-sec (prototype) exposure

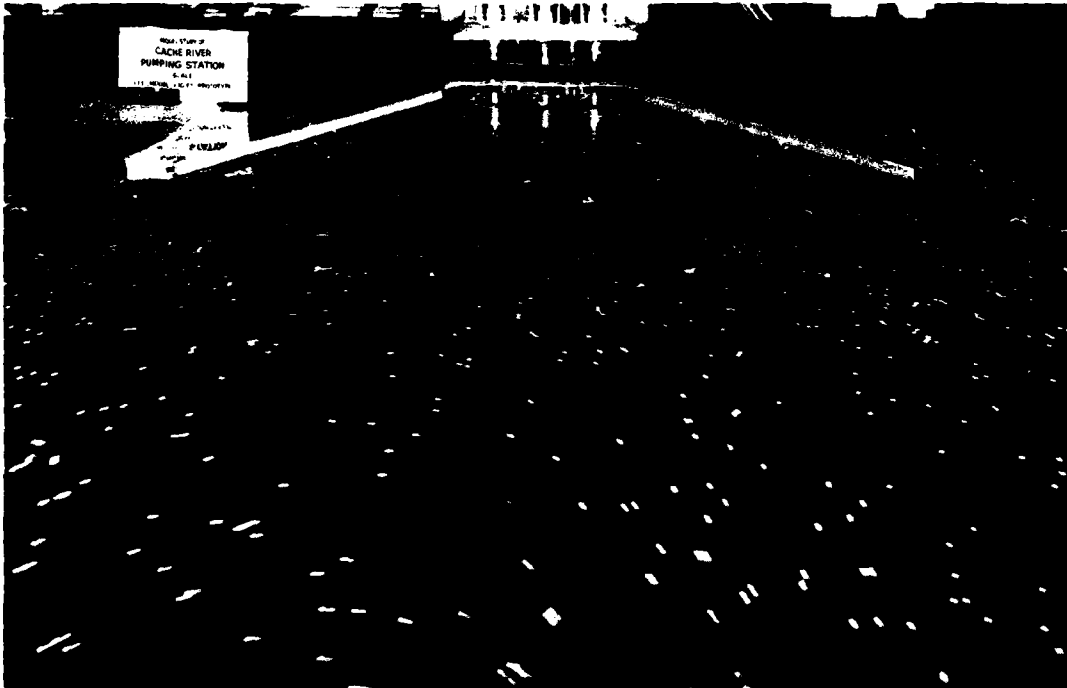
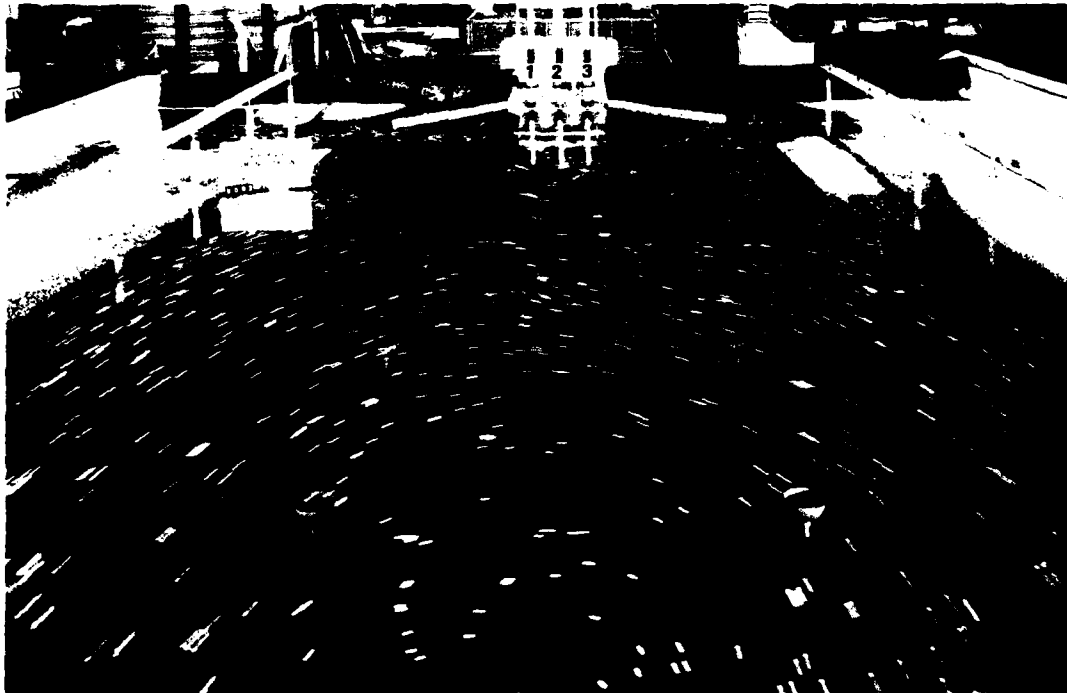

Photo 4. Flow patterns in approach channel, type 1 (original) design; water-surface el 313.7, pump 3 operating, 10-sec (prototype) exposure

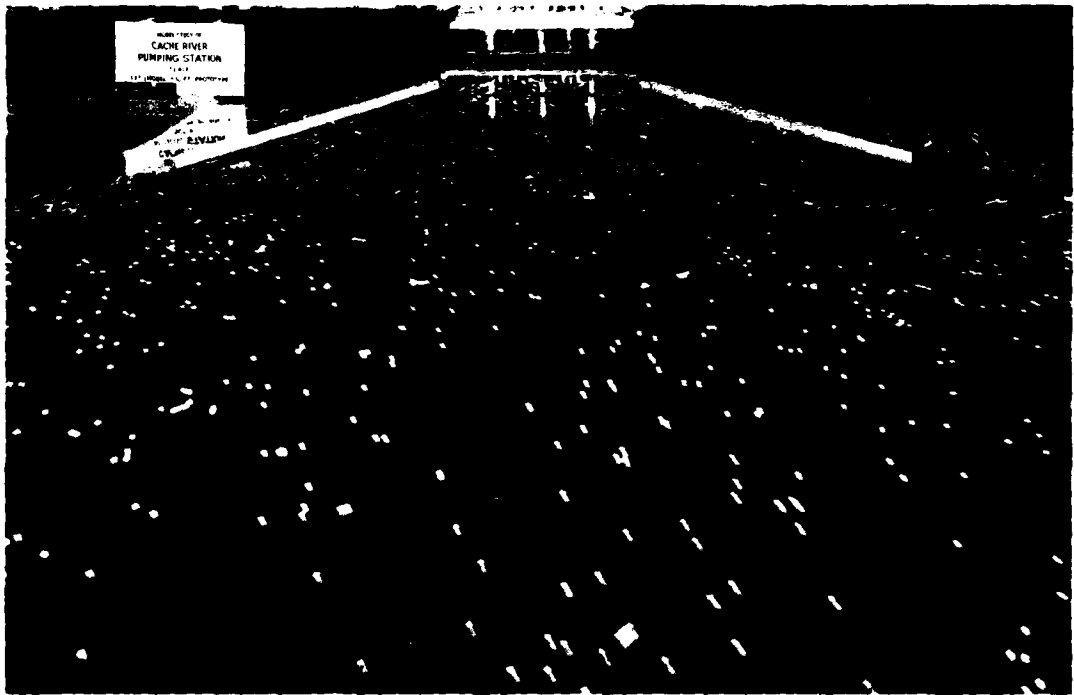
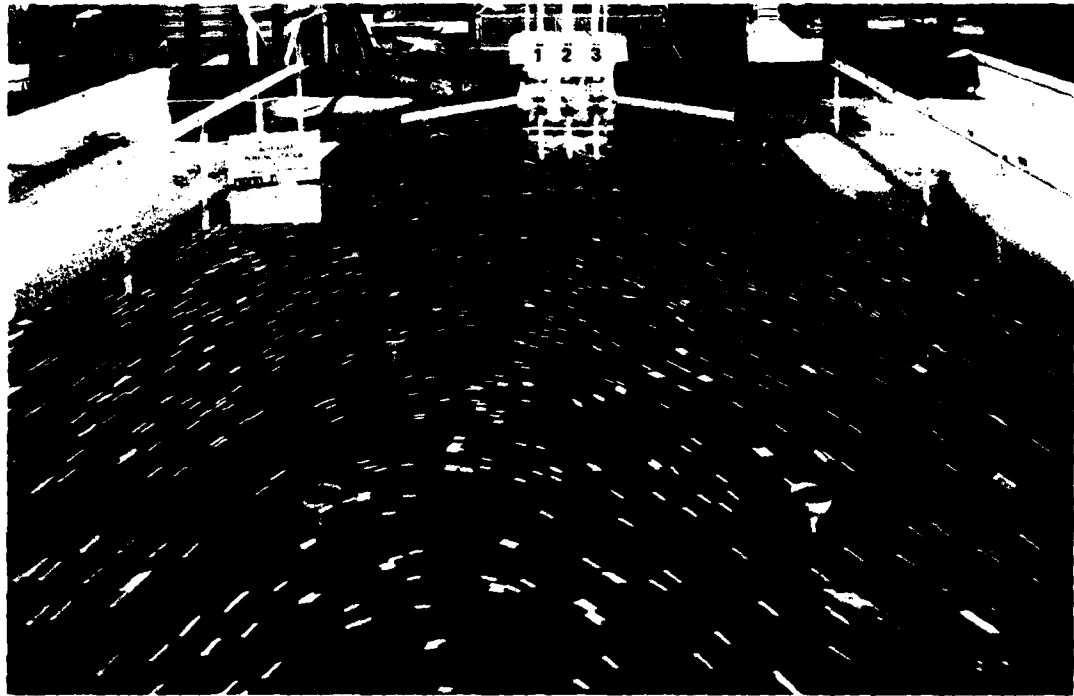

Photo 6. Flow patterns in approach channel, type 1 (original) design; water-surface el 313.7, pumps 1, 2, and 3 operating, 10-sec (prototype) exposure

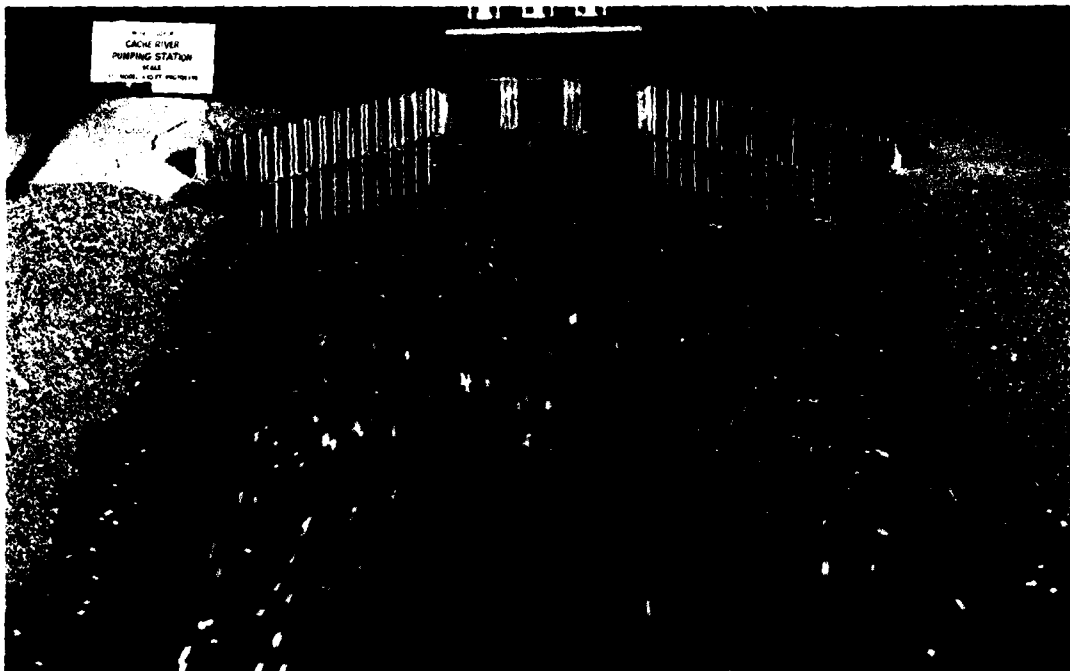

Photo 7. Flow patterns in approach channel, type 2 wing walls; water-surface el 306.0, pump 3 operating, 50-sec (prototype) exposure

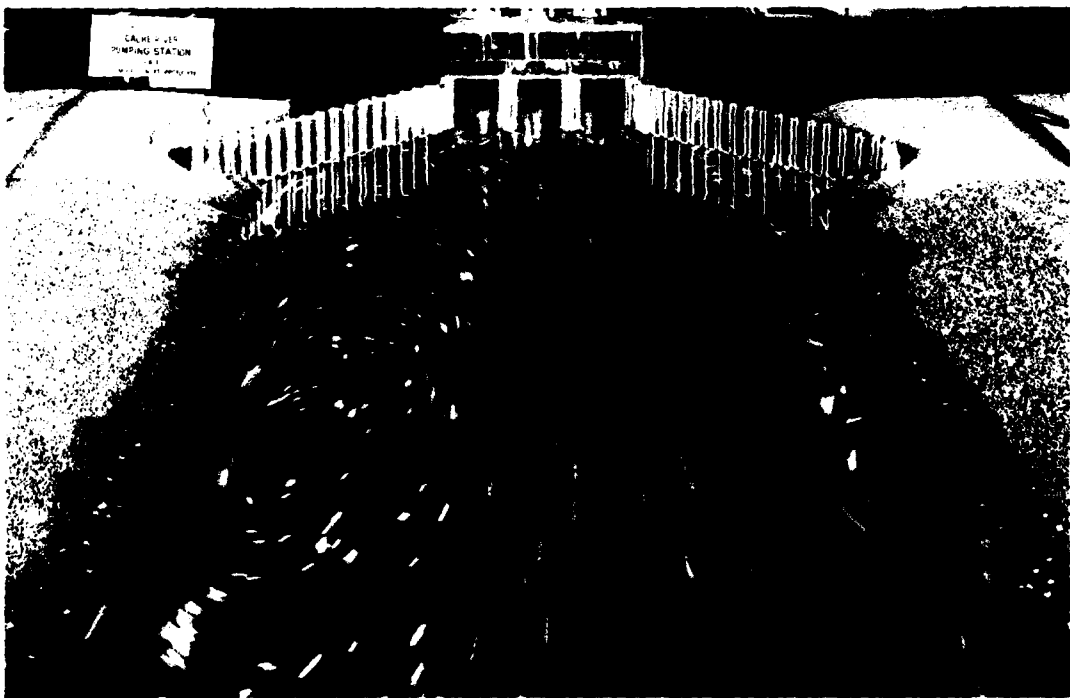

Photo 8. Flow patterns in approach channel, type 2 wing walls; water-surface el 306.0, pumps 2 and 3 operating, 50-sec (prototype) exposure

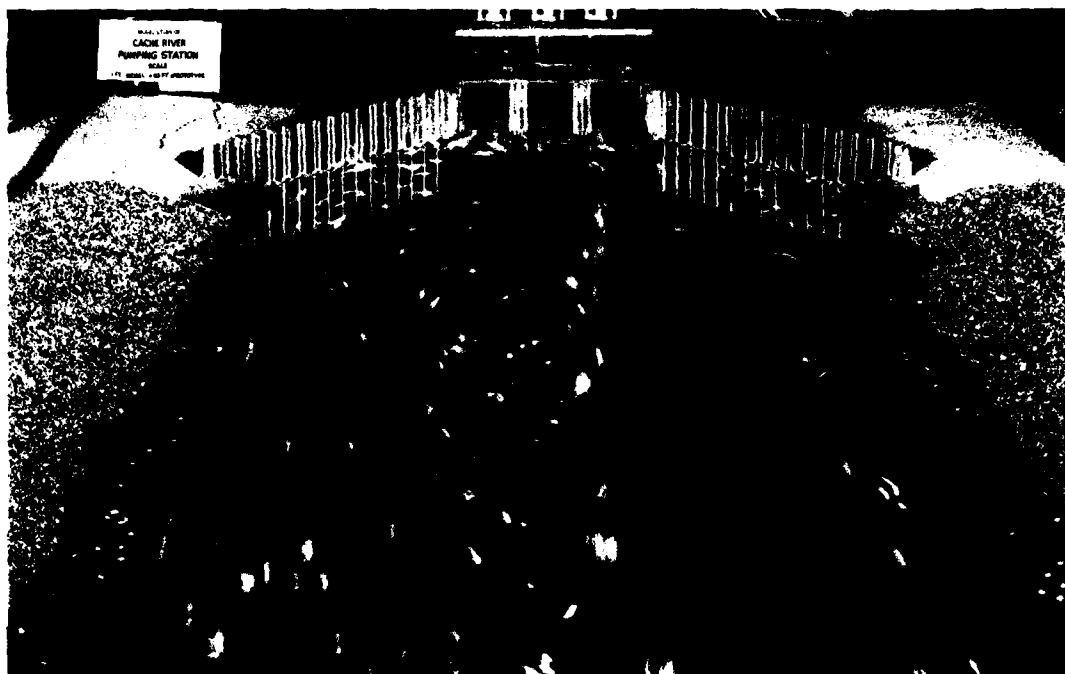

Photo 9. Flow patterns in approach channel, type 2 wing walls; water-surface el 306.0, pumps 1 and 2 operating, 50-sec (prototype) exposure



Photo 10. Flow patterns in approach channel, type 2 wing walls; water-surface el 306.0, pumps 1, 2, and 3 operating, 50-sec (prototype) exposure

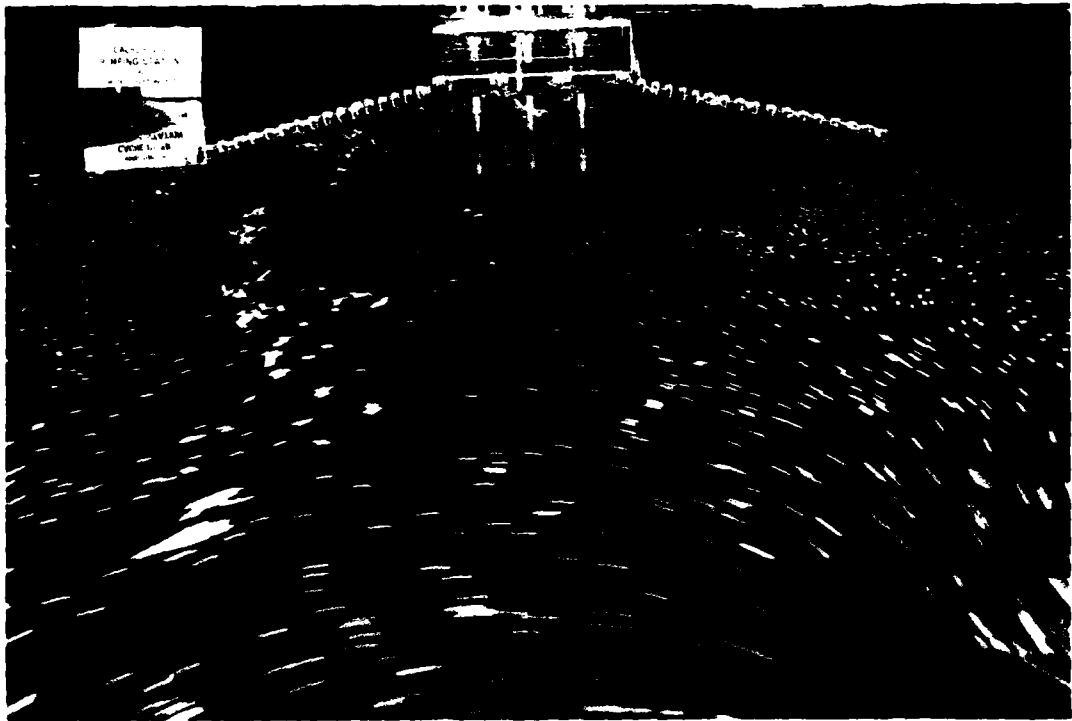
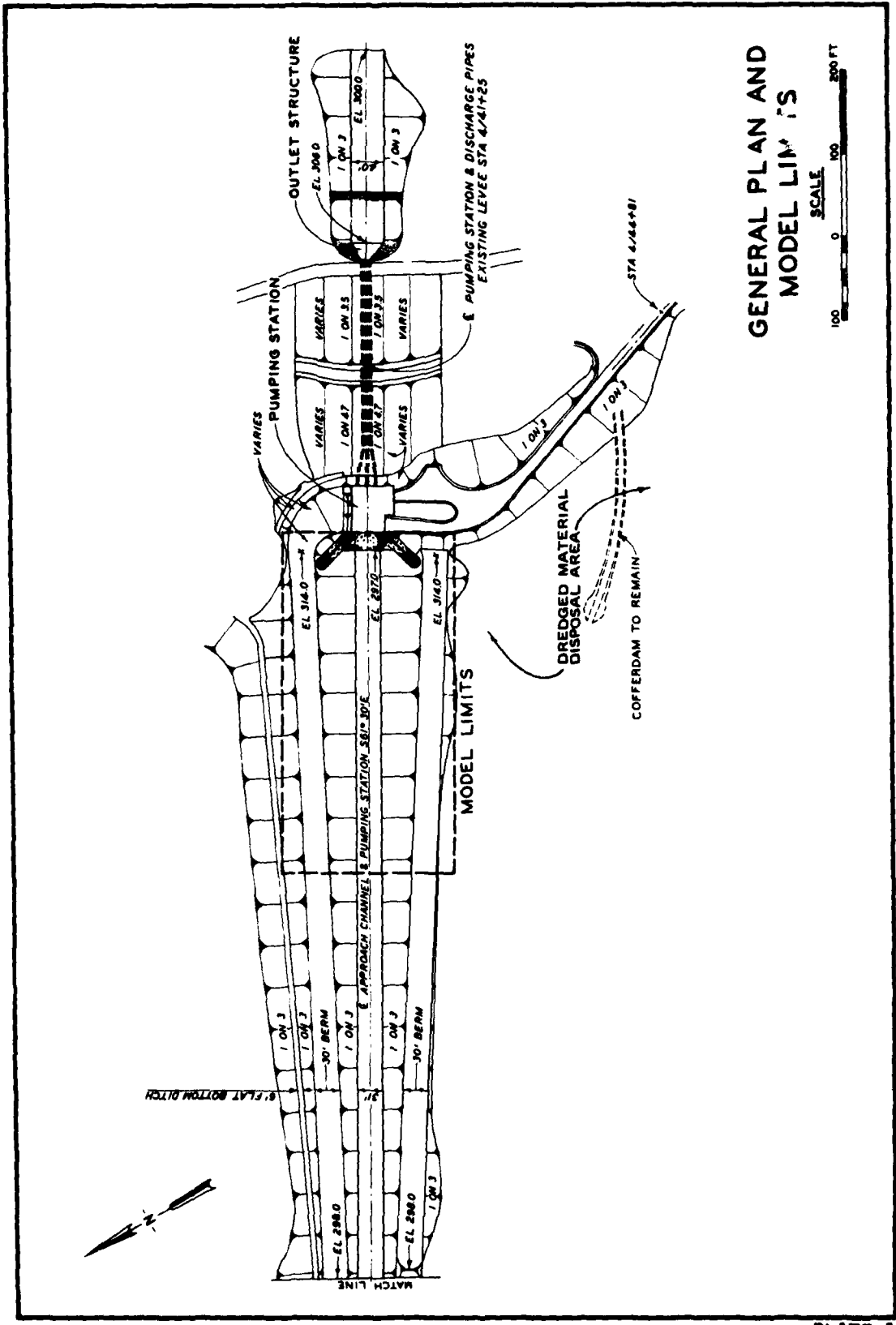

Photo 11. Flow patterns in approach channel, type 2 wing walls; water-surface el 313.7, pumps 1, 2, and 3 operating, 50-sec (prototype) exposure



**GENERAL PLAN AND
MODEL LIMITS**



PLATE 1

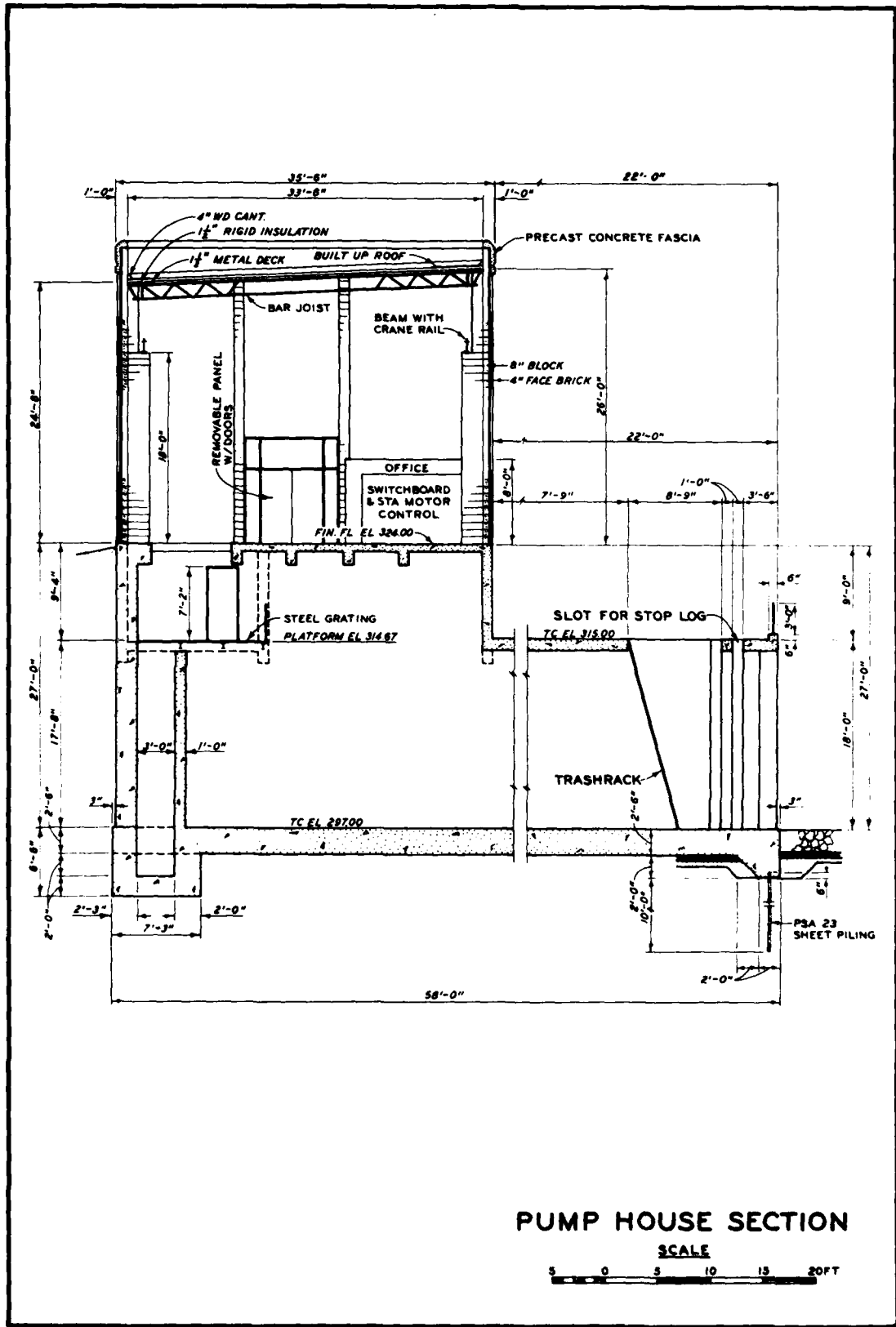
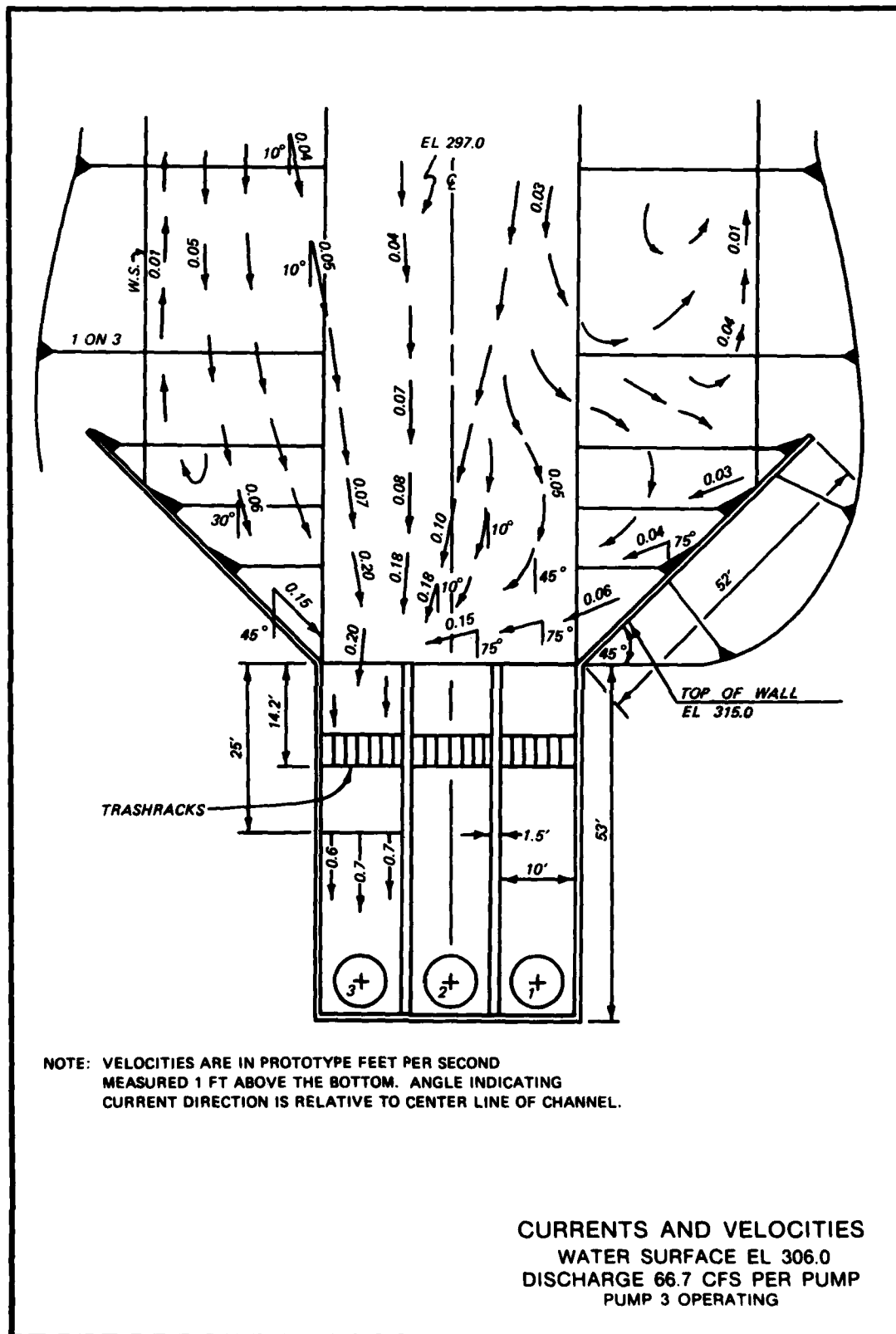

PLATE 4



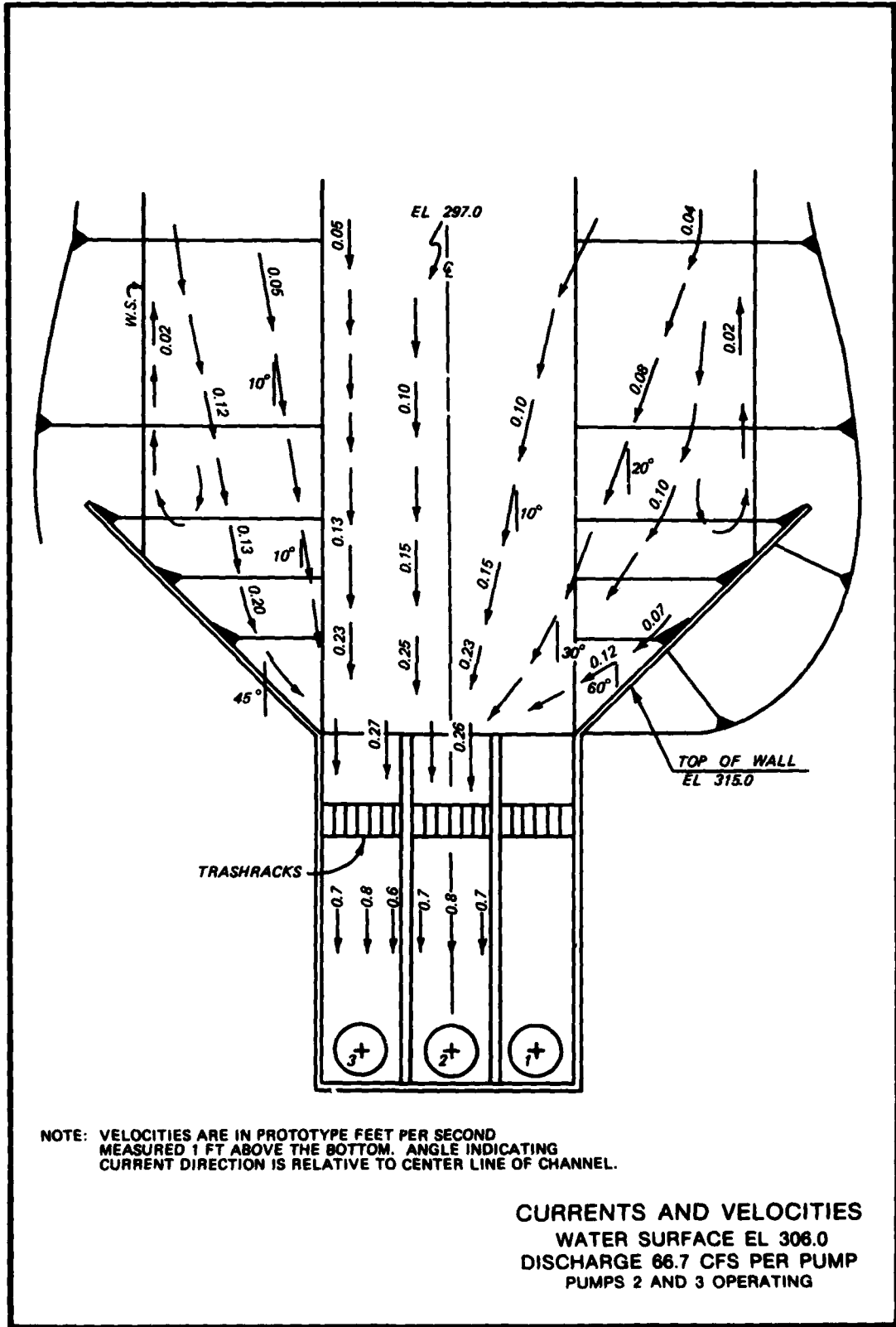
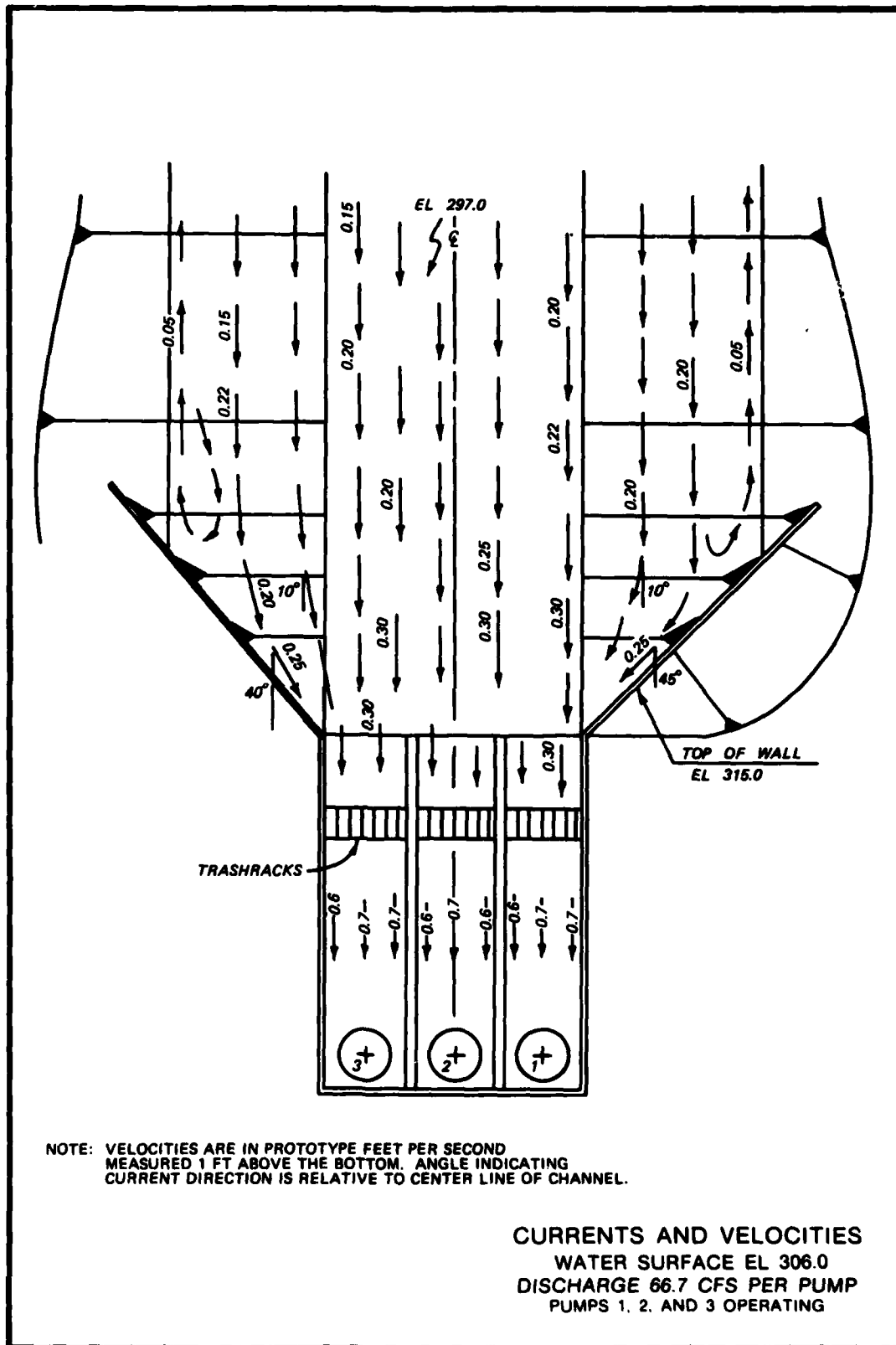

PLATE 6



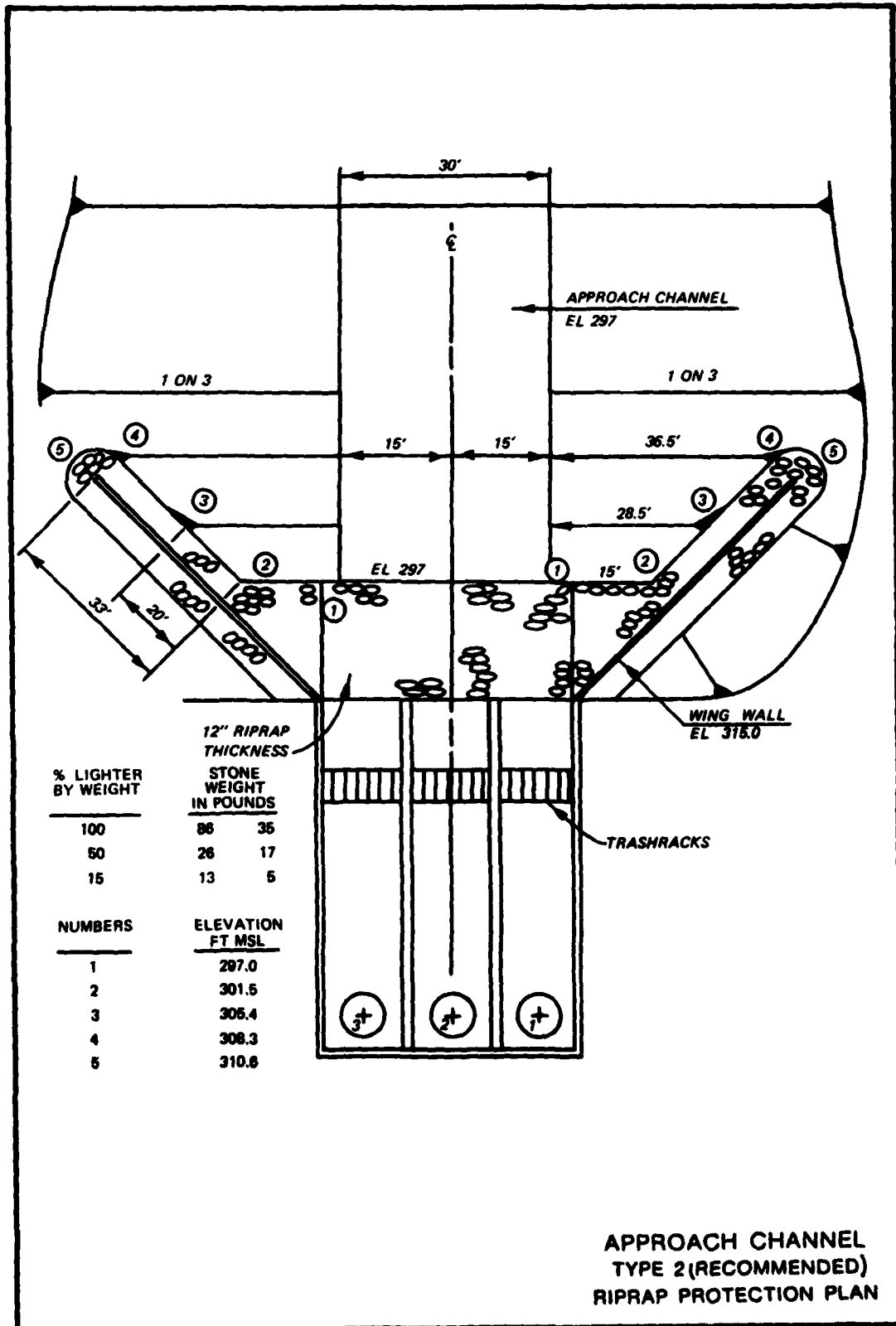

PLATE 8

In accordance with letter from DAEN-RDC, DAEN-ASI dated 22 July 1977, Subject: Facsimile Catalog Cards for Laboratory Technical Publications, a facsimile catalog card in Library of Congress MARC format is reproduced below.

Rothwell, Edward D.

Cache River Pumping Station south of Mound City, Illinois : Hydraulic model investigation / by Edward D. Rothwell, Bobby P. Fletcher (Hydraulics Laboratory, U.S. Army Engineer Waterways Experiment Station). -- Vicksburg, Miss. : The Station ; Springfield, Va. : available from NTIS, 1982.

17, [14] p., 8 p. of plates : ill. ; 27 cm. -- (Technical report ; HL-82-1)

Cover title.

"January 1982."

Final report.

"Prepared for U.S. Army Engineer District, Memphis."

1. Cache River Pumping Station. 2. Hydraulic models. 3. Pumping stations. I. Fletcher, Bobby P. II. United States. Army. Corps of Engineers. Memphis District. III. U.S. Army Engineer Waterways Experiment Station. Hydraulics Laboratory. IV. Title V. Series:

Rothwell, Edward D.

Cache River Pumping Station south of Mound City : ... 1982.
(Card 2)

Technical report (U.S. Army Engineer Waterways Experiment Station) ; HL-82-1.
TA7.W34 no.HL-82-1