



2.8 2.5

3.2 2.2

3.6 2.0

4.0 1.8

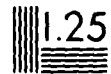

MIKROFILM-REPRODUKTION
VERFAHREN

12

DOT/FAA/RD-82/1
DOT/FAA/CT-81/33

Software Functional Description of Mass Weather Dissemination System Exploratory Engineering Model

ADA112706

L. Delemarre

Prepared By
FAA Technical Center
Atlantic City Airport, N.J. 08405

Final Report

February 1982

This document is available to the U.S. public
through the National Technical Information
Service, Springfield, Virginia 22161.

DTIC FILE COPY



U.S. Department of Transportation
Federal Aviation Administration
Systems Research & Development Service
Washington, D.C. 20590

DTIC
ELECTRONIC
MAR 31 1982
E

NOTICE

This document is disseminated under the sponsorship of the Department of Transportation in the interest of information exchange. The United States Government assumes no liability for the contents or use thereof.

The United States Government does not endorse products or manufacturers. Trade or manufacturer's names appear herein solely because they are considered essential to the object of this report.

Technical Report Documentation Page

1. Report No. DOT/FAA/CT-81/33		2. Government Accession No. 10 2000 006		3. Recipient's Catalog No.	
4. Title and Subtitle SOFTWARE FUNCTIONAL DESCRIPTION OF MASS WEATHER DISSEMINATION SYSTEM EXPLORATORY ENGINEERING MODEL				5. Report Date February 1982	
				6. Performing Organization Code	
7. Author(s) Louis Delemarre				8. Performing Organization Report No. DOT/FAA/CT-81/33	
9. Performing Organization Name and Address Federal Aviation Administration Technical Center Atlantic City Airport, New Jersey 08405				10. Work Unit No. (TRAIS)	
				11. Contract or Grant No. 131-401-835	
12. Sponsoring Agency Name and Address U.S. Department of Transportation Federal Aviation Administration Systems Research and Development Service Washington D.C. 20590				13. Type of Report and Period Covered Final	
				14. Sponsoring Agency Code	
15. Supplementary Notes					
16. Abstract This report describes the Mass Weather Dissemination System Exploratory Engineering Model software currently being evaluated in the Flight Service Station Engineering Laboratory. The object of this effort is to investigate, through development, test and evaluation, the application of digital technology to the dissemination of meteorological and aeronautical information. The prototype model is a fully-automated system designed to transfer a significant amount of workload from the flight service station specialist to system hardware/software in order to provide better service to the flying public.					
17. Key Words Flight Service Station Automation Utterance Recognition Device Pilots Automatic Telephone Weather Answering Service Multitasking Operating System			18. Distribution Statement Document is available to the U.S. public through the National Technical Information Service, Springfield, Virginia 22161		
19. Security Classif. (of this report) Unclassified		20. Security Classif. (of this page) Unclassified		21. No. of Pages 50	22. Price

METRIC CONVERSION FACTORS

Approximate Conversions to Metric Measures

Symbol	When You Know	Multiply by	To Find	Symbol
LENGTH				
in	inches	*2.5	centimeters	cm
ft	feet	30	centimeters	cm
yd	yards	0.9	meters	m
m	miles	1.6	kilometers	km
AREA				
m ²	square inches	6.5	square centimeters	cm ²
ft ²	square feet	0.09	square meters	m ²
yd ²	square yards	0.8	square meters	m ²
mi ²	square miles	2.6	square kilometers	km ²
	acres	0.4	hectares	ha
MASS (weight)				
oz	ounces	28	grams	g
lb	pounds	0.45	kilograms	kg
	short tons (2000 lb)	0.9	tonnes	t
VOLUME				
teaspoon	teaspoons	5	milliliters	ml
fl oz	tablespoons	15	milliliters	ml
c	fluid ounces	30	milliliters	ml
pt	cups	0.24	liters	l
qt	pints	0.47	liters	l
gal	quarts	0.95	liters	l
ft ³	gallons	3.8	liters	l
yd ³	cubic feet	0.03	cubic meters	m ³
	cubic yards	0.76	cubic meters	m ³
TEMPERATURE (exact)				
*F	Fahrenheit temperature	5/9 after subtracting 32)	Celsius temperature	*C

Symbol	When You Know	Multiply by	To Find	Symbol
LENGTH				
mm	millimeters	0.04	inches	in
cm	centimeters	0.4	inches	in
m	meters	3.3	feet	ft
m	meters	1.1	yards	yd
km	kilometers	0.6	miles	mi
AREA				
cm ²	square centimeters	0.16	square inches	in ²
m ²	square meters	1.2	square yards	yd ²
km ²	square kilometers	0.4	square miles	mi ²
ha	hectares (10,000 m ²)	2.5	acres	
MASS (weight)				
g	grams	0.035	ounces	oz
kg	kilograms	2.2	pounds	lb
t	tonnes (1000 kg)	1.1	short tons	
VOLUME				
ml	milliliters	0.03	fluid ounces	fl oz
l	liters	2.1	pints	pt
l	liters	1.06	quarts	qt
m ³	liters	0.26	gallons	gal
m ³	cubic meters	35	cubic feet	ft ³
m ³	cubic meters	1.3	cubic yards	yd ³
TEMPERATURE (exact)				
*C	Celsius temperature	9/5 (then add 32)	Fahrenheit temperature	*F

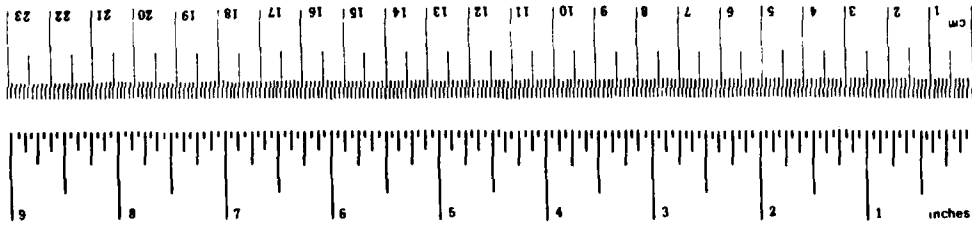

*In 1.254 exactly. For other exact conversions and more detailed tables, see NBS Mon. Publ. 75-350, Units of Weights and Measures, Pt. 2, Sec. 2.5, 3D, Circular No. C1, 3-10-286.

TABLE OF CONTENTS

	Page
INTRODUCTION	1
Purpose	1
Background	1
HISTORICAL DEVELOPMENT OF THE SYSTEM	4
General	4
Minicomputer Selection	6
File Management Description	7
Functional Description of the Mass Weather Dissemination Exploratory Engineering Model	9
Description of Program Flow Chart for the Mass Weather Dissemination Exploratory Engineering Model	10
Description of the Manual Voice Input Subsystem Flow Diagrams of the Mass Weather Dissemination System	22
Functional Description of System Tasks and Devices	34
CONCLUSIONS	44
RECOMMENDATIONS	45



Accession For	
NTIS GRA&I	★
DTIC TAB	□
Unannounced	
Justification	
By _____	
Distribution/	
Availability Codes	
Dist	Avail and/or Special
A	

LIST OF ILLUSTRATIONS

Figure		Page
1	Functional Description of the Trial PATWAS Operations	2
2	Mass Weather Dissemination Exploratory Engineering Model	4
3	Program Flow Chart for the Mass Weather Dissemination Exploratory Engineering Model (9 pages)	11
4	Manual Voice Input Subsystem Flow Diagram (11 pages)	23
5	Functional Block Diagram of System Software	35

INTRODUCTION

PURPOSE.

The purpose of this document is to provide a concise functional software description of the Mass Weather Dissemination Exploratory Engineering Model.

BACKGROUND.

The New York City Pilots Automatic Telephone Weather Answering Service (PATWAS) test provided some valuable information pertaining to pilot acceptance and manpower savings of such an automated system. A functional description of the PATWAS system as it existed in New York City has been excised from the final report No. FAA-RD-77-80,1 (reference 1) and is quoted below.

"Each of the three trial PATWAS messages is composed of five message segments arranged to provide for rapid message update. Each segment is recorded on an endless-loop magnetic tape cartridge. During the message segment recording process, a cue tone is placed immediately at the end of each message segment. The cue tone is used to trigger the start of the next message segment. The detection of the cue tone and start of the next message segment is so rapid as to be undetectable by the listener.

"The trial PATWAS is an assemblage of data acquisition equipment, studio quality recording/playback equipment, and telephone company equipment. Briefing data are acquired from the Weather Message Switching Center (WMSC) via a 110-baud American Standard Code for Information Interchange (ASCII) dedicated line. The data are received by a Hazeltine 2000 cathode ray tube (CRT) terminal equipped with a thermal printer. Software changes made at the WMSC computers facilitated an automatic text preparation for the update of the various recordings.

"Message segments are read from a prepared script into a microphone. The resulting utterances are recorded on a separate cartridge recorder/player. Immediately following the recording process, the message segments are auditioned for content and clarity. The updated message segment is then manually loaded into the appropriate cartridge slot in the message player, replacing the former segment.

"Access to the message player is through the telephone company supplied barge-in equipment. The system operates as shown in figure 1. A pilot calls the appropriate telephone number. If no one else is connected to the message he has dialed, completion of his call starts the message at the beginning. From that time, each message segment is sequenced until he terminates the call. After he hangs up, the message will continue to sequence to the end of the last segment and then stop. If additional pilots should call while the initiating pilot is still connected to the system, the system will continue to play as long as anyone remains connected. As described elsewhere, pilots acquiring the system through the barge-in equipment do not always get the message at the beginning — hence the term barge-in."

The conclusions given at the end of the report on the New York City PATWAS test, stated that positive acceptance of the PATWAS system among the general aviation community was indicated and a substantial decrease in the number and length of

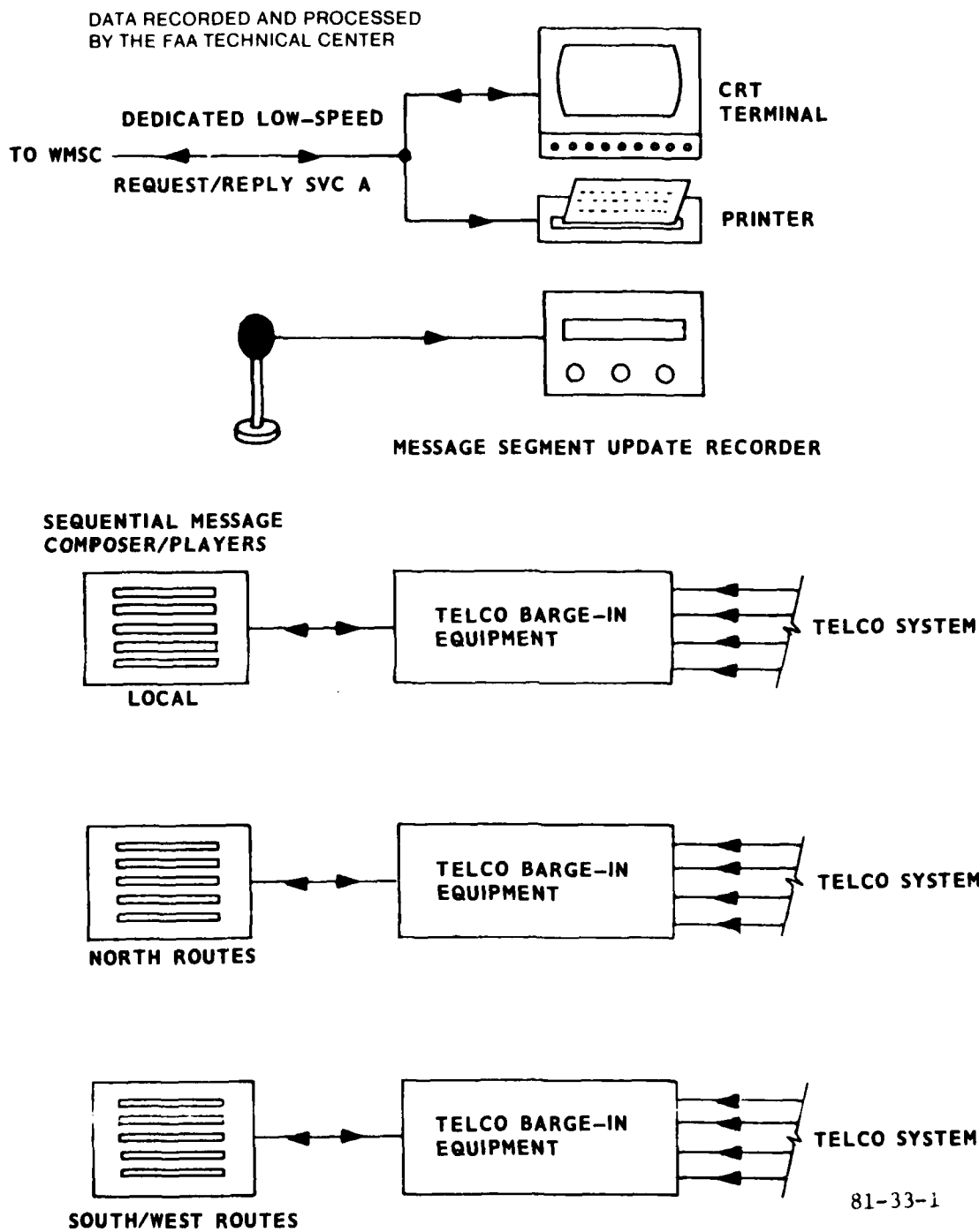

FIGURE 1. FUNCTIONAL DESCRIPTION OF THE TRIAL PATWAS OPERATIONS

Flight Service Station (FSS) person-to-person briefings was achieved as a direct result of the PATWAS system. It was also noted that the general aviation public strongly favored the route-oriented briefing technique incorporated in the system.

A few shortcomings were also observed in the New York City PATWAS system and were pointed out as potential areas for improvement in any future work in this facet of the FSS automation effort. Some of the more important areas of improvement are noted below:

1. The "barge-in" connection was found to be inconvenient to the pilot, since it had a tendency to increase his line-hold time to obtain complete message content, which increases line costs of the system making it undesirable as a functional in-the-field system.
2. The speech quality of the recordings need improvement with respect to speech consistency and audio recording levels.
3. "One-call" service was considered to be a desirable feature by many of the subjects that used the system.

The New York City PATWAS test proved without a doubt that a system configuration of this type would meet with general aviation public acceptance and would reduce the workload of the FSS specialist by a significant amount. It was further observed that research and development of the system should be conducted in the following areas:

- a. Noninterrupting fast-time updating of weather information
- b. Multiple message storage
- c. Accessing message at beginning
- d. Multiple message availability of any telephone line
- e. One telephone number access
- f. Automatic message composition
- g. Centralized message composition
- h. User selection of specific message segments.

The conclusions and recommendations found in this report provided the impetus for the mass weather dissemination exploratory engineering model developed at the Federal Aviation Administration (FAA) Technical Center and described in this report.

The reader is referred to figure 2 for clarification of interrelationship of system elements in the following development discussion.

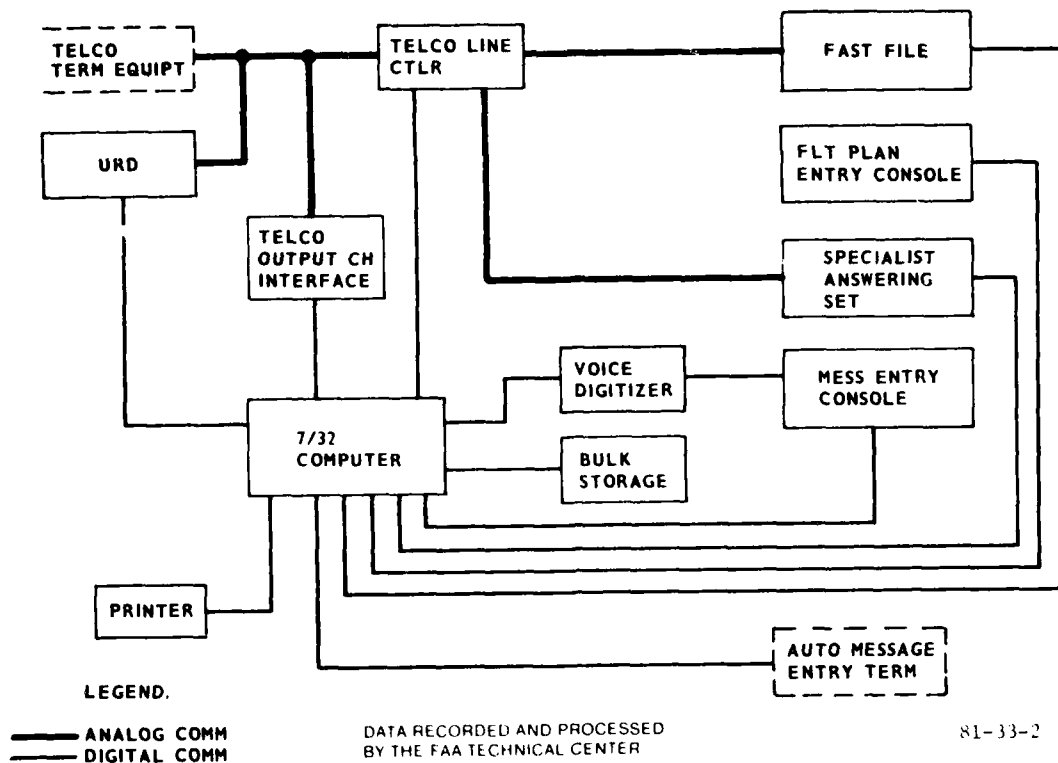

FIGURE 2. MASS WEATHER DISSEMINATION EXPLORATORY ENGINEERING MODEL

HISTORICAL DEVELOPMENT OF THE MASS WEATHER DISSEMINATION SYSTEM

GENERAL.

The mass weather dissemination system exploratory engineering model developed at the FAA Technical Center was modeled after the magnetic tape cassette system used for experiment at LaGuardia. This PATWAS system incorporated some innovative concepts, but also had some severe limitations. The PATWAS tape system's major advantage is the ability to update segments of the total message, rather than the entire message, due to the fact that the tape transport sequenced through a number of cassettes via queue tone controls recorded on the tape along with the audio data. This feature allowed for the segmentation of a route-oriented briefing into a subset of message segments, thus allowing for partial message update capability.

The major drawbacks to this tape system were that each tape transport which constitutes a route-oriented briefing, is attached to a Telephone Company (Telco) barge-in system. Severe system limitations were experienced, due to the

hardwired nature of fabrication and the lack of artificial intelligence to make decisions. Two of the most prominent problems which plagued the system are described below.

1. When the first pilot accesses a quiescent tape transport constituting a briefing, he initiates the message and proceeds to sequence through the tapes comprising this briefing; if now a second pilot accesses this briefing, he barges-in picking up the briefing at the point in time that the first pilot has progressed into the message. Since the second pilot is listening to the message out of context, he more than likely will have to sequence through the briefing which is inconvenient to the pilot and increases his line-hold time which is costly to the government.

2. The other major problem encountered in the system is the inability to have message-to-line multiplexing. What is meant by this is that each barge-in system has a number of phone lines hard-wired to it and if a pilot calls a briefing system which is fully utilized, he will receive a busy signal even though other lines on different briefing systems may be available. This inability to switch a desired briefing to a designated line mandates inefficient line utilization at an FSS installation.

With these thoughts in mind, it was decided to try to incorporate the ability to update a portion of a briefing, rather than recording the entire message, and in addition, have synchronous access and message-to-line multiplexing utilizing digital technology as the artificial intelligence of the system. Synchronous access is now readily available since the artificial intelligence, a general purpose minicomputer, can randomly access the binary data which constitutes a particular briefing from a mass storage media, transfer this binary data to an audio output channel which converts this data from the digital domain back into analog signals, reproducing the original spoken word content of the briefing. In addition, assuming a man-machine interface exists between pilot and system, the minicomputer can ascertain that the pilot requires a northbound route-oriented briefing; and randomly access this particular data from the mass storage media and disseminate this information to the pilot via the audio output board, thus achieving the goal of switching a designated message to a designated phone line. The man-machine interface mentioned above could be either a Touch-Tone™ mechanism or a word recognition device.

Some additional system options could now be included because of the artificial intelligence incorporated into the system. Since the ability exists to interrogate the pilot as to how the system can be of service to him, he now has the ability, along with obtaining a route-oriented briefing, to request to file, close out, amend a flight plan, or to talk to a specialist to assist him in matters not obtainable, otherwise, in the system. In order to incorporate these functions into the system, three devices would have to be included in the system architecture which are specified below:

1. A digitally-controlled analog tape recorder had to be developed that could be directed to perform specific functions, depending on system file options requested by the pilot. Among the commands required would be record, rewind, replay, and filemark. With this repertoire of commands and the interaction of man and system, it is possible to file and review a flight plan without human intervention.

2. A digitally-controlled handset that the computer could sense, if available and if so, generate an alert signal to a specialist that a pilot required human assistance. In addition, the handset would have to communicate back to the system that the specialist-pilot communication was done or the specialist had to go off-line and would not accept the call. The computer could then take the appropriate action to further assist the pilot.

3. A crosspoint switch mechanism would have to be fabricated and incorporated into the system, again under computer control, in order to achieve the audio switching necessary to get a specified phone line to a specific system option.

With the inclusion of these items in the system, it is evident that the pilot has a much broader range of services available to him, than those available in the magnetic tape PATWAS system. The pilot could now have the ability to acquire a route-oriented briefing and file a flight plan, with or without specialist assistance, by a single call access to the system.

MINICOMPUTER SELECTION.

The minicomputer selected as the artificial intelligence of the system was the Perkin-Elmer Interdata 7/32. Some of the salient features of this computer, which made it desirable for our particular applications, are listed below.

1. The ability to communicate with up to 1,024 peripheral devices attached to the computer's multiplexer bus.
2. A 32-bit machine architecture making possible the ability to directly address multiple megabytes of memory.
3. An operating system that provided many desirable features built-in, along with a real-time, multitasking environment.

After the audio input/output boards were designed and fabricated to be compatible with the bus structure and interrupt protocols of the interdata machine, it was necessary to produce a software driver for the boards which would allow a new operating system to be generated. This new "SYSGENED" operating system could then treat the alien devices as though it were any standard interdata driver/peripheral product, allowing the system to handle the audio input/output boards as "logical units," thereby making them attachable to tasks present in the multitasking environment. This marriage of the in-house designed audio boards to the operating system was necessary in order to take advantage of the powerful features built into the operating system software.

One of the features of the operating system that was very desirable was the support of a multitasking environment. This environment was necessary since the overall system would produce a number of interrupts, some of which were time-critical while others were not. An example of a time-critical interrupt is one from an audio board. The board has two on-board buffers, one of which is playing out as audio; the other to be filled with the next sequential binary data. From this it can be seen that if the second buffer is not filled by the time the first buffer is exhausted, an interruption in audio output will result. An example of a nontime-critical interrupt is a communication entered by the specialist to the system, from his display terminal. The system intercepts these interrupts at the firmware level

and processes them into system queues which are then disseminated to the appropriate tasks' queue list. The system works in an asynchronous nature with respect to these interrupts which would result in a mix of time-critical and nontime-critical queues in the tasks' queue list. Since the task has to handle its queue list in a sequential fashion, rather than on a priority basis, it is evident that a time-critical queue could miss getting serviced within the given time window. Since the operating system along with being multitasking, allows the tasks to be assigned a system priority, it is seen that the problem of servicing this mix of system queues can be resolved. The solution is to segregate time-critical queues to tasks with a high system priority and nontime-critical queues in tasks with lower system priority. In this manner, the critical queues will be serviced by the system before the nontime-critical queues get system attention.

Another feature of the operating system which was felt would greatly enhance our development time of the mass weather dissemination exploratory engineering model was the file management software incorporated as part of the operating system environment. In order to achieve system throughput efficiency to the level necessary to service the required 20 audio boards simultaneously, a marriage had to be made between existing file management software in the operating system and a pseudo-file management software package developed in-house.

FILE MANAGEMENT DESCRIPTION.

The first file management technique experimented with was the indexed file structure, since this provided the most ease of implementing and provided the most efficient utilization of the storage media. When this file management method was employed to handle the briefing data, it was determined that each audio board required 20 percent of the overall system for file management and other system overhead. This large overhead figure was, in large part, due to the double buffering of the data, once at the system level and again at the task level. The manner in which indexed files are generated is another reason which contributes to the slow response. A data request may require multiple seeks on the storage device because of the random nature in which it is written on the media; thus increasing the total response time by the additional seeks being done. Since this tremendous overhead would reduce the number of boards that could be serviced simultaneously down to five boards; the indexed file management technique had to be aborted, despite its very efficient utilization of the storage media and ease of implementation.

The next file management technique pursued was the contiguous file manager. This management scheme does not encounter the problems inherent in the indexed file management. The information is not double buffered; it is transferred directly from the storage media to the task's storage buffer. In addition, because of the nature of a contiguous file, information within the file can be positioned randomly; and then read in a sequential manner from that point to satisfy the request, thus eliminating additional seek times to the overall response time of a read request. The contiguous file management overhead, for these reasons, is drastically reduced. The total system overhead per board was reduced from 20 percent to 5 percent, which brought the system much closer to the desired specification of being able to simultaneously service 20 audio boards.

The contiguous file management is not without its short comings, however. The major drawback to this management method is that in order to allocate a contiguous file on the storage media, the size of the file has to be known at time of allocation, since a continuous physical area of the specified size has to be found on the media. This phenomenon generates some severe problems. Most obvious of these problems becomes evident immediately; i.e., the specialist does not know the time duration of a message segment until he speaks it into the system; therefore, a contiguous file cannot be allocated for this segment beforehand.

The solutions to this aforementioned problem, although rectifying the condition, are not considered viable solutions due to either excessive overhead or inefficient utilization of the storage media. One such solution would be to attach an indexed file first and speak the segment allowing the system to expand the indexed file, as necessary, to accommodate the segment and upon completion, now knowing the size of the file, allocate a contiguous file of sufficient capacity to then transfer the indexed file counterpart; the indexed file could then be deleted. It is evident that this technique would incur a great deal of system overhead. Another possible solution is to preallocate contiguous files on the storage media of various time durations; i.e., 1 minute, 2 minutes, etc. It is obvious that this would be both very cumbersome to the specialist to have to fit a message segment within a specified time slot or by attaching a file of considerably larger capacity than anticipated for the segment, cause inefficient utilization of the storage media. Additional system overhead is also incurred from the attaching and closing of these contiguous files to a specified task and deletion of noncurrent segment files.

In order to take advantage of the efficiencies obtained by using the contiguous file manager and not incur the deficiencies just described, a pseudo-file manager was conceived and developed in-house and implemented into the system at the task level. The mass storage media eluded to in the previous discussion is a fixed head disc. One track of the 256 tracks on the fixed head disc holds approximately 4 seconds worth of digitally encoded speech. On this basic premise, an algorithm was written to maintain records on track utilization. The name given to this track management algorithm was random-contiguous track management.

The first order of business was to allocate a contiguous file on the disc of a size that required all of the available storage area on the media. Now, by attaching five files to a task, since the system has five fixed head discs, 20 megabytes of binary data (85 minutes worth of speech) is available to this task. Next, it is necessary to have a track map in core for each of the discs to indicate which tracks are available for use and which tracks are dedicated to an already existing segment. Finally, a segment table is required to indicate the sequence of tracks to play out to generate a specified segment within a desired route-oriented briefing.

In essence, the algorithm would go through the following sequence. Once it is ascertained which route-oriented briefing is desired, the route table is accessed to see if the first segment is active and if it is, fetches its segment block address within the segment table. Within this segment block are a number of binary words which indicate both the disc and track number that should be accessed and disseminated. When this track is exhausted, the next word is fetched and a similar operation is performed. In this manner, tracks are sequenced through until the last track is accessed, indicated by a bit within the word. Embedded within the

word is also the information of how much of the last track to play out in order to eliminate dead time at the end of the segment. The algorithm would then access the route table to see if the next segment is active and if it is, go through a similar process just described. In this manner, the entire briefing would be disseminated, playing all segments within it that are presently active.

By the nature in which the algorithm functions, it is evident that a segment can be of any duration, within the bounds of available storage, because of the process of looking for an available track anywhere within the five media. If a segment block is filled, the algorithm will automatically look for another available segment block within the segment table and use the last word of the old segment block to point to the new segment block which will contain the remainder of the track/disc information for that segment.

A final point that should be noted is that additional overhead is eliminated because no file manipulations are performed, such as attaching or closing out a file to a task. Additionally, when an out-dated segment is to be deleted, no action is taken on the physical media; instead, the tracks which constituted this segment are made available again in the appropriate track maps, making deletions a very expeditious procedure.

FUNCTIONAL DESCRIPTION OF THE MASS WEATHER DISSEMINATION EXPLORATORY ENGINEERING MODEL.

The mass weather dissemination exploratory engineering model is composed of the following functional components:

1. Telco line controller
2. Telco output channel interface
3. Interdata 7/32 computer
4. Printer
5. Bulk store
6. Voice digitizer
7. Fast file
8. Flight plan entry console
9. Specialist answering set
10. Message entry console

Figure 2 shows the interrelationship of these elements as a system.

The Telco line controller and output channel interface are the elements that connect the system to the outside world. The Telco line controller alerts the computer of such conditions as ring detect, customer disconnect, and also provides pickup condition for the phone line. The Telco output channel interface is the device that converts the digital speech data in the bulk storage back into analog signals compatible with the phone line environment.

The Interdata 7/32 computer is the decisionmaking element of the system and controls the flow of the caller through the system, depending on options specified by the pilot calling in. The computer is capable of switching the caller to any of the system options specified, via use of a crosspoint switch array and crosspoint controller. The computer also decides what system question, statement, or weather message will be disseminated to the pilot over the output channel interface.

The message entry console, voice digitizer, and bulk store constitute the elements necessary to enter weather messages into the system for dissemination over the phone line. The specialist issues commands from his position which are interpreted by the computer and executed to fulfill the request. An example of such a transaction would be as follows:

The specialist would "talk" a valid segment name which constitutes one of the components of a route-oriented briefing. The computer would accept the binary information from the voice digitizer, store this information on an available area of the bulk storage devices; and finally, place pointers in memory for retrieval by the playback algorithm so that this information can be disseminated at the appropriate time in the specified route-oriented briefing.

The fast-tape recorder, flight plan entry console, and printer comprise the elements necessary for handling flight plans in the system. When a pilot says "file," the computer switches him, via the crosspoint switch/controller, to an analog tape recorder which is under digital control by the computer. By use of this configuration, the system can record a flight plan, allow the pilot to review or amend a flight plan; and finally, to close out a flight plan. The flight plan entry position allows the specialist to enter the flight plan information from the analog tape into the system, by means of a keyboard/display terminal. The information is processed and properly formatted for transmission on the service "B" circuit. A hard copy of the flight plan can also be obtained from the printer for local retention of the flight plan at the originating FSS.

The specialists' answering sets are an in-house automatic telephone call distributor system handled in the software domain. When a pilot requests a "specialist," the computer looks for an available position and issues a ring command to that position. If the specialist picks up the handset, the computer connects the pilot's telephone line to the appropriate handset, via the crosspoint switch/controller. At completion of the communication between pilot and specialist, the handset sends a signal to the computer which prompts the playing of a "system" question asking the pilot if the system can be of any further assistance. If the specialist, at the time of a "ring" condition on his handset has a higher priority task to perform, he can place his handset "off-line," which alerts the computer that this position is now not available and to scan the system for another available handset. If a handset cannot be found, the pilot is placed on a "wait" list until a handset becomes available.

DESCRIPTION OF PROGRAM FLOW CHART FOR THE MASS WEATHER DISSEMINATION EXPLORATORY ENGINEERING MODEL.

To describe the program logic flow of the system, a narrative description of a typical transaction between pilot and system, with multiple options selected, will be given. For the sake of clarity, perfect recognition will be assumed and the short form of the questions and statements will be requested. The interested reader can follow the flow sequence for these circumstances in the flow chart (figure 3) and listings of the system questions and statements, included here for the reader's convenience.

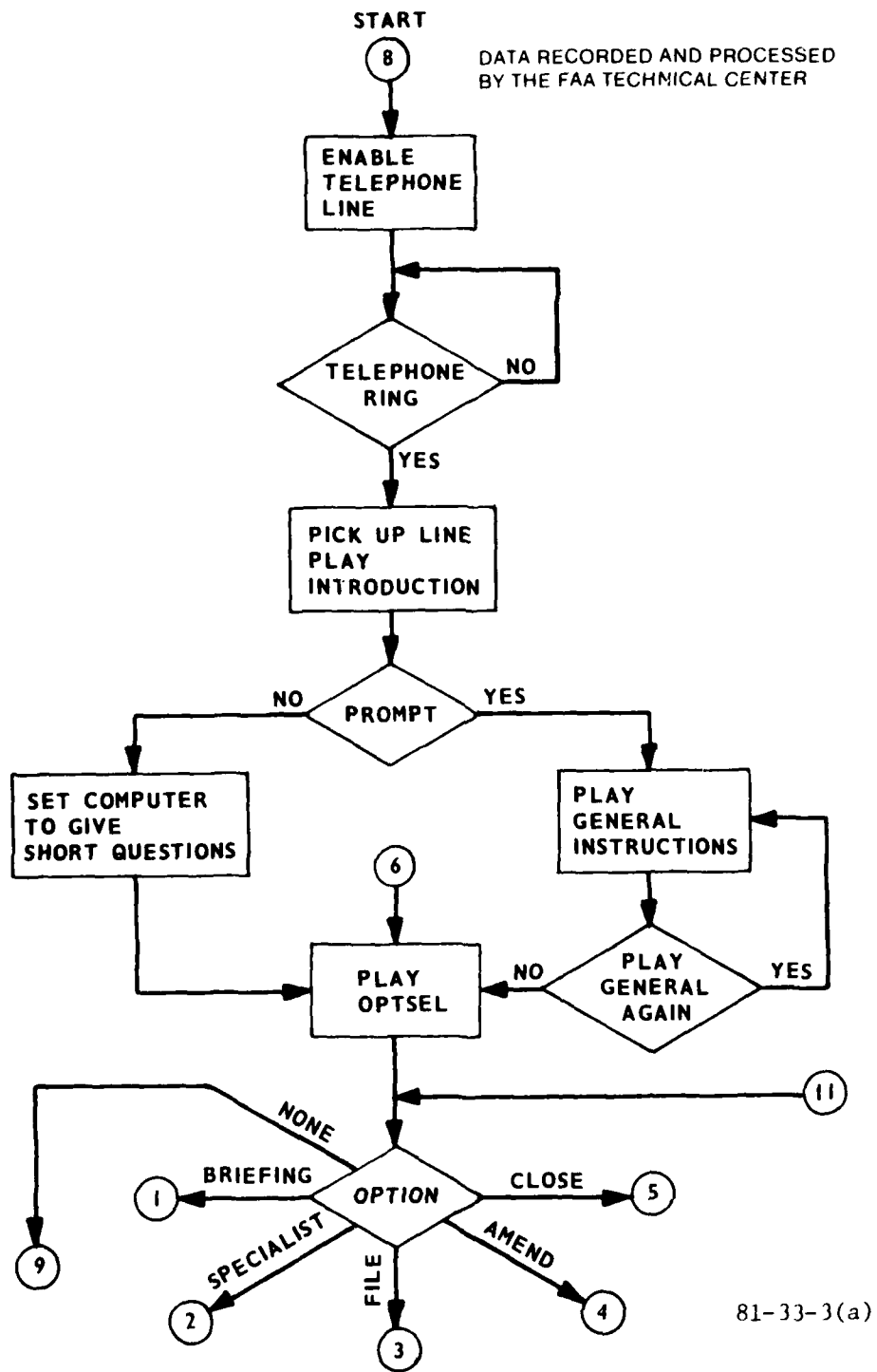

FIGURE 3. PROGRAM FLOW CHART FOR THE MASS WEATHER DISSEMINATION EXPLORATORY ENGINEERING MODEL (1 of 9)

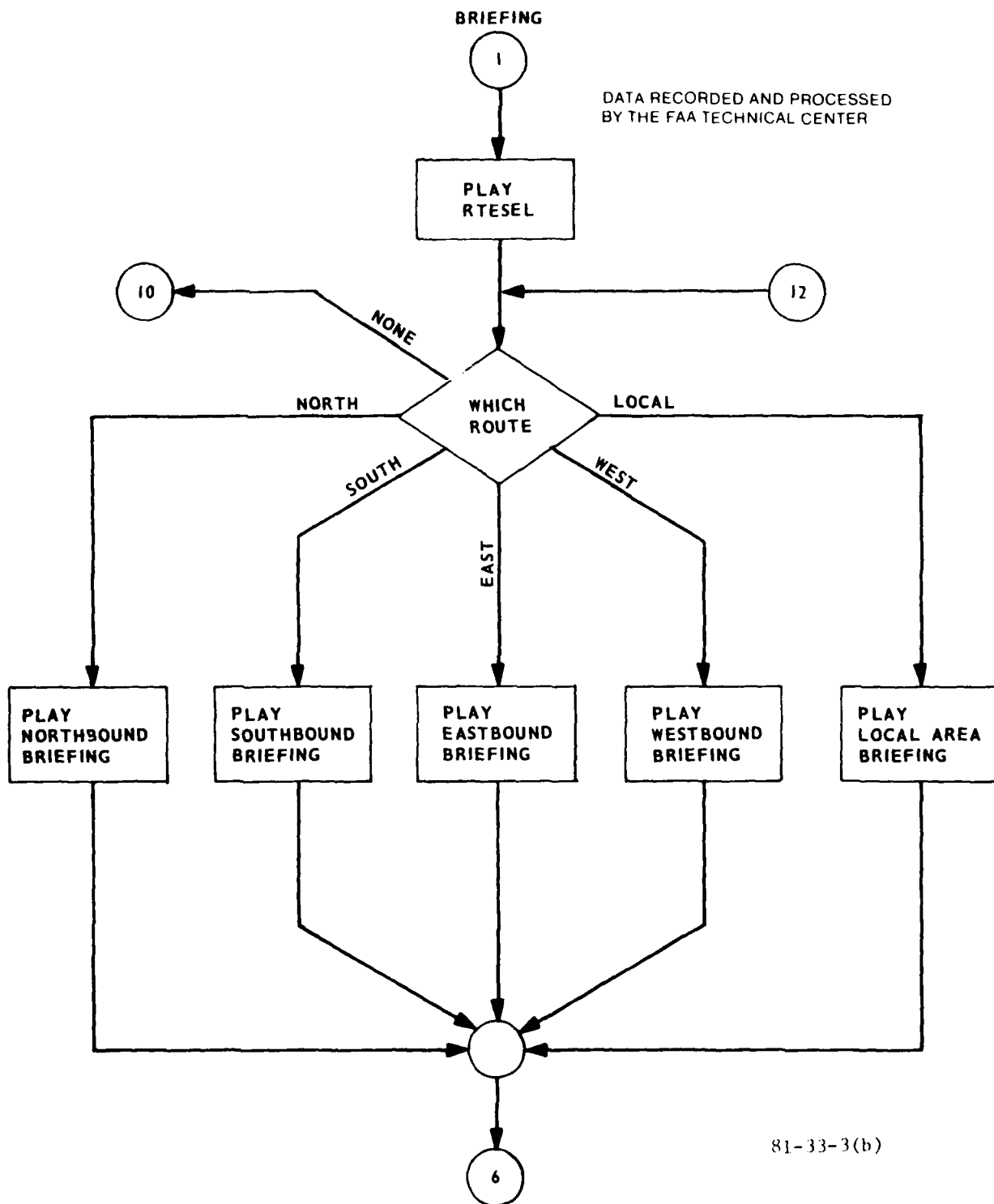

FIGURE 3. PROGRAM FLOW CHART FOR THE MASS WEATHER DISSEMINATION EXPLORATORY ENGINEERING MODEL (2 of 9)

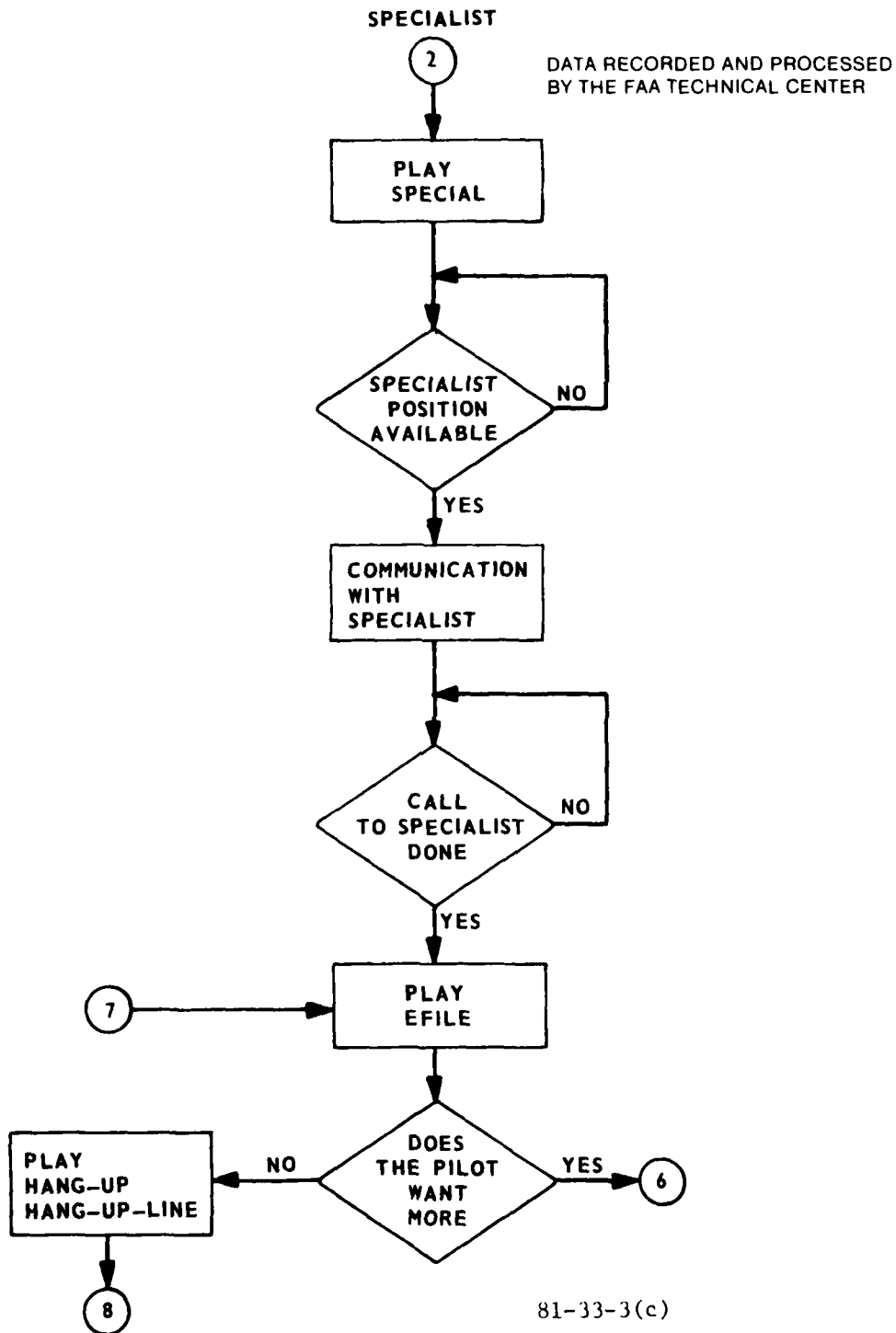

FIGURE 3. PROGRAM FLOW CHART FOR THE MASS WEATHER DISSEMINATION EXPLORATORY ENGINEERING MODEL (3 of 9)

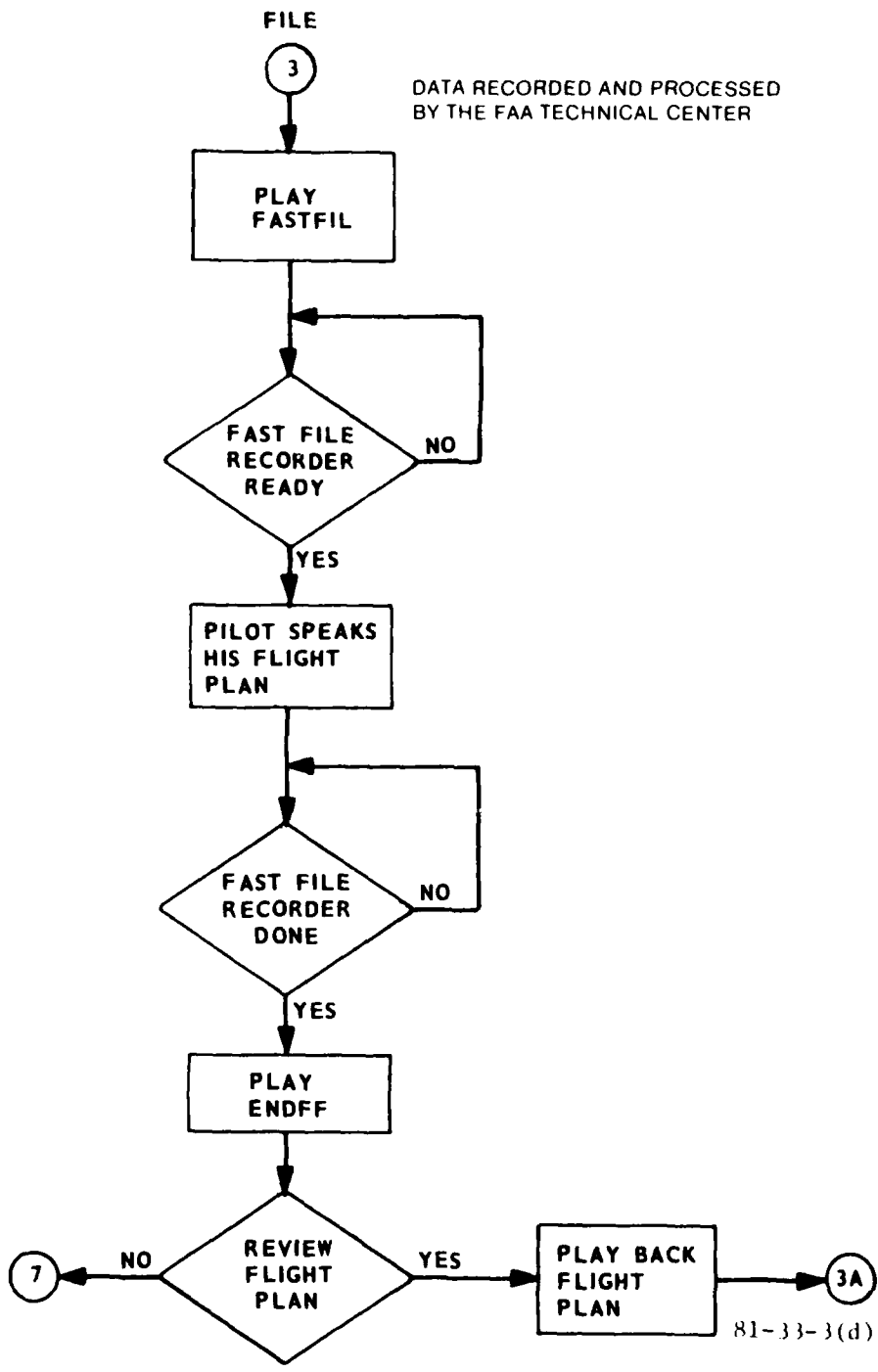

FIGURE 3. PROGRAM FLOW CHART FOR THE MASS WEATHER DISSEMINATION EXPLORATORY ENGINEERING MODEL (4 of 9)

DATA RECORDED AND PROCESSED
BY THE FAA TECHNICAL CENTER

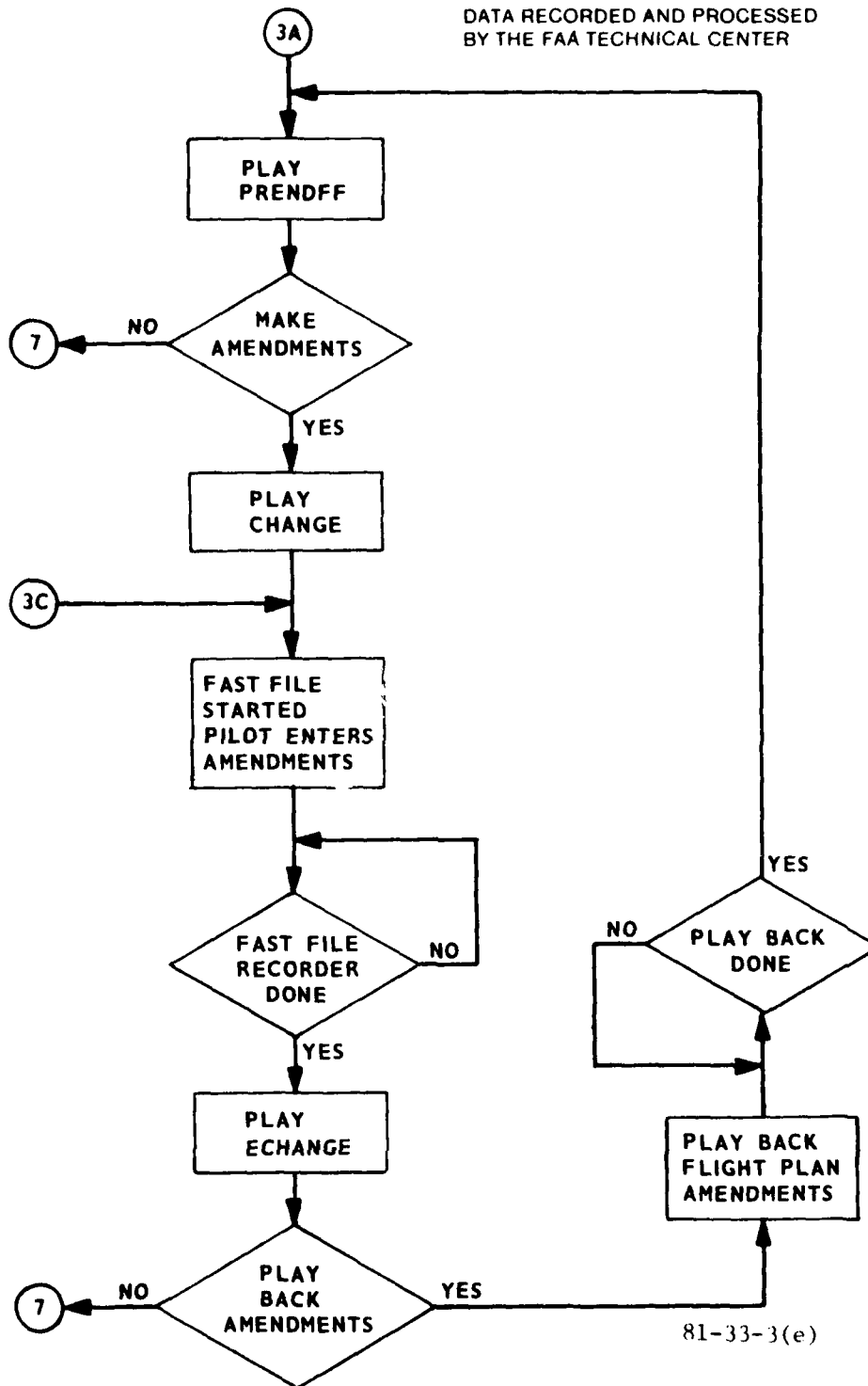
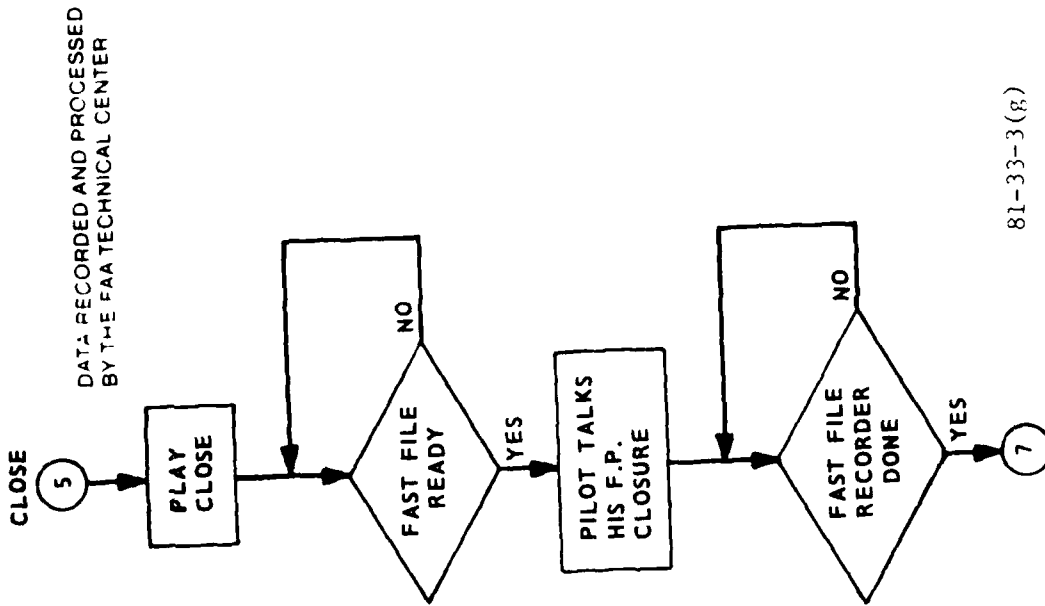
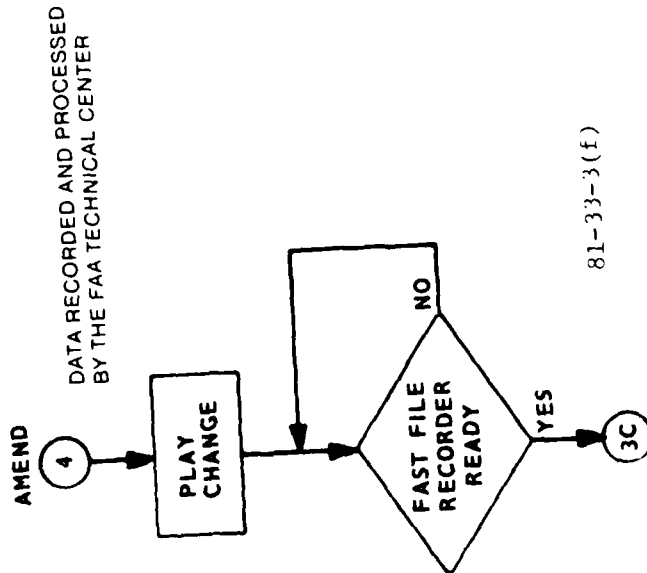

FIGURE 3. PROGRAM FLOW CHART FOR THE MASS WEATHER DISSEMINATION EXPLORATORY ENGINEERING MODEL (5 of 9)



81-33-3(g)

FIGURE 3. PROGRAM FLOW CHART FOR THE MASS WEATHER DISSEMINATION EXPLORATORY ENGINEERING MODEL (7 of 9)



81-33-3(f)

FIGURE 3. PROGRAM FLOW CHART FOR THE MASS WEATHER DISSEMINATION EXPLORATORY ENGINEERING MODEL (6 of 9)

ERROR CORRECTION

OPTION CORRECTION

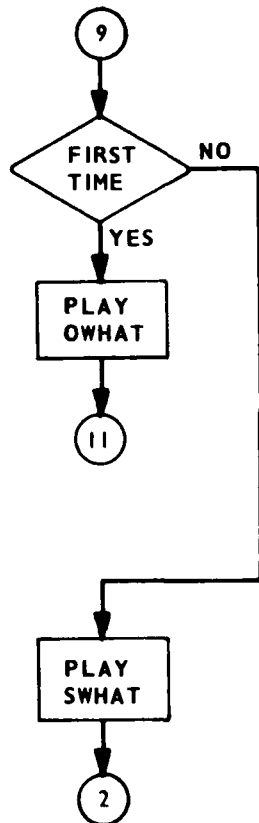

ROUTE CORRECTION

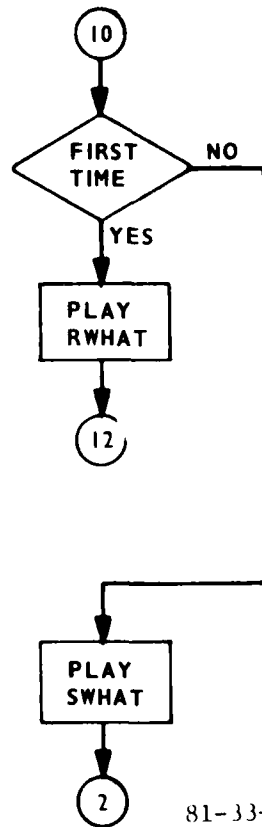

81-33-3(h)

DATA RECORDED AND PROCESSED
BY THE FAA TECHNICAL CENTER

FIGURE 3. PROGRAM FLOW CHART FOR THE MASS WEATHER DISSEMINATION EXPLORATORY ENGINEERING MODEL (8 of 9)

ERROR CORRECTION FOR YES/NO

THIS ROUTINE IS ENTERED
WHEN ANY YES/NO
QUESTION GETS A NO
RESPONSE* FROM THE URD

*NO RESPONSE MEANS THAT THE
WORD WAS NOT RECOGNIZED.

DATA RECORDED AND PROCESSED
BY THE FAA TECHNICAL CENTER

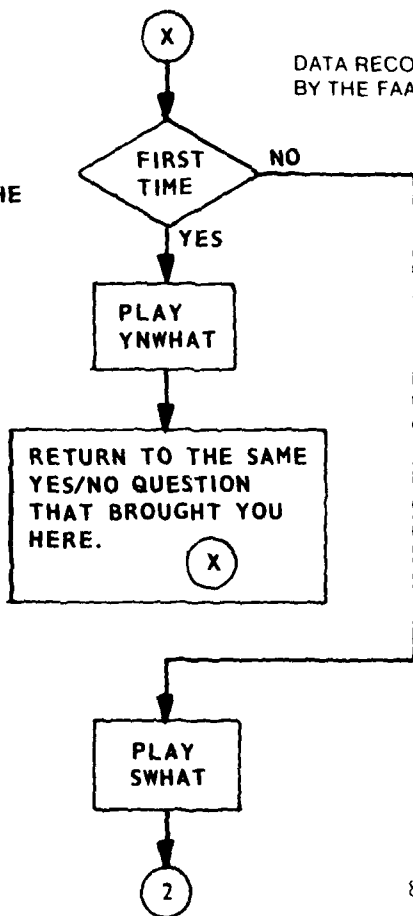

81-33-3(i)

FIGURE 3. PROGRAM FLOW CHART FOR THE MASS WEATHER DISSEMINATION
EXPLORATORY ENGINEERING MODEL (9 of 9)

Upon reception of a "ring" signal on one of the Telco line controllers, the computer is alerted to this fact and, in response, the computer directs the appropriate Telco output channel interface board to execute a pickup function and then disseminate the introduction to the pilot which poses the first question pertaining to whether the caller needs detailed operating instructions. If the caller's response is "no," the computer conditions this board's output to the short form of system questions and statements for the duration of the transaction.

The next question asked of the pilot is "OPTSEL" which requests which system option the pilot would like to use. Let us assume the first order of business is a route-oriented briefing. Upon reception of the word "briefing" from the pilot, the system responds with another question (RTESEL) which requests which of the five route-oriented briefings he wishes to hear. For discussion purposes, let us assume the caller says the word "north." The system would then disseminate the current northbound briefing to the pilot.

At the conclusion of the briefing, the system question "EFILE" is played asking the pilot if he requires any further information or assistance. Let us assume the pilot needs some specific information not contained in the briefing and desires to talk to a specialist. With this being the case, the pilot would say "yes" to the "EFILE" question, at which time the "OPTSEL" question is played to the pilot. At the conclusion of this question, the pilot would speak the word "specialist." The computer would then play the system statement "special" which informs the pilot that he should standby for a specialist.

At the conclusion of the conversation between the pilot and specialist, the system again asks the question "EFILE," asking the pilot if it can be of any further assistance. Let us suppose the pilot has sufficient information to fly and now wishes to file a flight plan. The pilot again would say "yes" to the "EFILE" question and the word "file" to the "OPTSEL" question. The system would then play out the statement "FASTFIL" which tells the pilot to standby to speak his flight plan immediately after the queue tone.

At the end of his flight plan, the pilot remains silent for 5 seconds which alerts the computer that the flight plan has been completed. The system question "ENDFF" is then played to the pilot which asks him if he would like to review his flight plan. Let us assume a "yes" answer to this question; this would cause the computer to issue a rewind/play command to the fast file recorder which allows the pilot to hear the flight plan he has just spoken into the system.

When the flight plan review is completed, the system comes back to the pilot with the question "PRENDFF" which asks the pilot if he would like to make any amendments to his flight plan. Assume that the pilot detected an error in his flight plan and wishes to correct the erroneous information. This being the case, the pilot would say "yes" to the "PRENDFF" question, at which time the system issues a statement telling the pilot to standby to speak his flight plan amendment immediately after the queue tone.

At the conclusion of this iteration, the system asks the question "ECHANGE" which wants to know if the pilot would like to review his flight plan amendments. For the sake of discussion, let us assume the caller would like to confirm that the system obtained his changes properly. The caller would then respond with a "yes"

to the "ECHANGE" question, which prompts the computer to send a rewind/play command to the fast file recorder, allowing the pilot to review his flight plan amendments. When the playback is finished, the computer again disseminates the "PRENDF" question to the pilot asking if he wants to make any changes to his now modified flight plan.

Let us assume the pilot is now satisfied with his flight plan and says "no" to the "PRENDF" question. The system would then ask the question "EFILE" requesting the pilot if the system can be of any further assistance. Since the pilot has accomplished his goal, he would say "no" to the "EFILE" question which would motivate the computer to play the "hangup" statement wishing the pilot a good day and issuing a hangup command to the Telco line controller.

Other permutations that a pilot would generate while using the system would follow a similar logical flow through the accompanying chart. Other minor flow sequence variations would be generated internally by the system; in the case of a misinterpretation of an utterance or a nonconfirmation of a yes/no question, verification of a system function requested.

The following is a tabulation of utterances to be issued by the PABS while engaged in dialog with the pilot. Two sets of utterances, one more detailed than the other, are provided.

INTRODUC Hello, this is the Pilots' Automated Briefing System. Detailed operating instructions are available for the new or occasional user. Do you wish detailed operating instructions? Please say "yes" or "no" immediately after the cue tone.

If the answer to INTRODUC is "no" the following set of utterances will be used.

QOPTSEL Say "briefing," "file," "amend," "specialist," or "close."

QRTESEL Say "north," "south," "east," west," or "local."

QSPECIAL Standby for a specialist.

QFASTFIL Standby to speak your flight plan immediately after the cue tone.

QENDFIL Do you wish your flight plan played back?

QPRENDF Do you wish to amend your flight plan?

QCHANGE Standby to speak your flight plan amendment immediately after the cue tone.

QECHANGE Do you wish to play back your flight plan amendment?

QEFILE Do you require additional assistance?

QHANG-UP Thank you. Have a good day.

QOWHAT The computer did not understand you. Say again "briefing," "file," "amend," "specialist," or "close."

QRWHAT The computer did not understand you. Say again "north," "south," east," "west," or "local."

QCLOSE Standby to close out your flight plan immediately after the cue tone.

QYNWHAT The computer did not understand you. Say again yes or no.

If the answer to INTRODUCE is "yes", the following set of computer utterances will be used.

GENERAL During the briefing you will be asked to speak certain words to the computer. We ask that you speak clearly, only one word at a time, and only immediately after the cue tone.

If the computer asks you to "please repeat" say your last word again immediately after the cue tone.

If the computer questions your last word, for example "was that north: please say "yes" or "no" immediately after the cue tone.

If the computer does not respond in approximately 3 seconds, please say your last word again louder.

Do you wish a replay of the information just presented? Say "yes" or "no" immediately after the cue tone.

OPTSEL You may select one of five system options. You may select any of four route-oriented briefings or a local area briefing. You may speak your flight plan into fast file, amend a previously entered flight plan, or close out a flight plan. You may speak to a Flight Service Specialist. You may terminate this call at any time by merely hanging up. Immediately after the cue tone, please say "briefing," "file," "specialist," "amend," or "close."

RTSEL To select a generally northbound route-oriented briefing say the word "north." Similarly, say "east," "south," or "west" for other route-oriented briefings, or the word "local" for a local area briefing. Immediately after the cue tone say "north," "east," "south," "west," or "local."

SPECIAL Standby for a specialist.

FAST FIL You will be connected to the fast-file system. Standby! Immediately after the cue tone speak your flight plan. The computer will interpret 5 seconds of silence as completion of your flight plan. When you have finished, remain silent until the computer comes back to you.

END FF Do you wish to play back your flight plan? Please say "yes" or "no."

PREND FF Do you wish to make amendments to your flight plan? Please say "yes" or "no."

CHANGE You will be connected to the "fast-file" system. Standby! Immediately after the cue tone speak your flight plan amendments. Say the word "amend," identify yourself, your aircraft, and previously entered estimated time of departure. When you have finished, standby, the computer will come back to you.

ECHANGE Do you wish to play back your flight plan amendments? Please say "yes" or "no."

EFILE Do you require any further information or assistance? Please say "yes" or "no."

HANG-UP Thank you. Have a good day.

OWHAT The computer did not understand you. Please speak clearly immediately after the cue tone one of the following words: "briefing," "file," "amend," "specialist," or "close."

RWHAT The computer did not understand you. Please speak clearly immediately after the cue tone one of the following words: "north," "east," "south," "west," or "local."

SWHAT The computer did not understand you. Please standby for a specialist.

CLOSE You will be connected to the "fast-file" system. Standby! Immediately after the cue tone, say the word "close" followed by your name, aircraft, I.D., and time of day.

YNWHAT The computer did not understand you. Please speak clearly after the cue tone either the word "yes" or "no."

JAM The fast file recorder has jammed. Standby for a flight service specialist who will accept your flight plan. Please tell the specialist the recorder is jammed.

DESCRIPTION OF THE MANUAL VOICE INPUT SUBSYSTEM FLOW DIAGRAMS OF THE MASS WEATHER DISSEMINATION SYSTEM.

In order to describe the logic flow of the manual voice input subsystem, a few specialist command/machine response iterations will be described and can be followed by referring to figure 4. The logic flow involving the random-contiguous track management will be left to the interested reader to follow, since a narrative description of the algorithm is considered too tedious to include here and outside the scope of this report.

Let us assume the specialist has a new terminal forecast ("FT") for the northbound route to enter into the system for dissemination to the aviation public. The first order of business would be to "map" the northbound route to see if the "FT" segment is currently active. The computer would interpret the command and operand

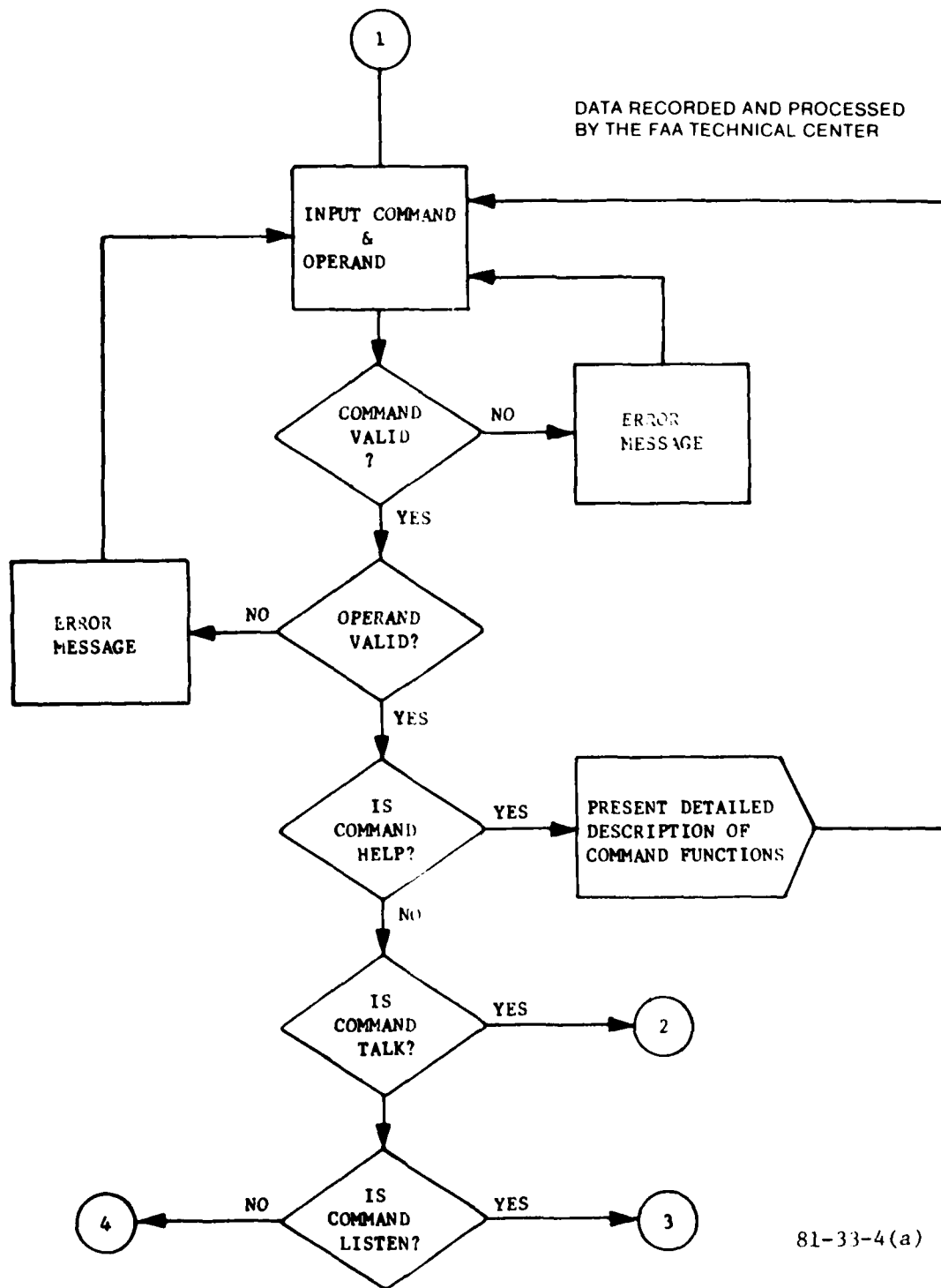

81-33-4(a)

FIGURE 4. MANUAL VOICE INPUT SUBSYSTEM FLOW DIAGRAM (1 of 11)

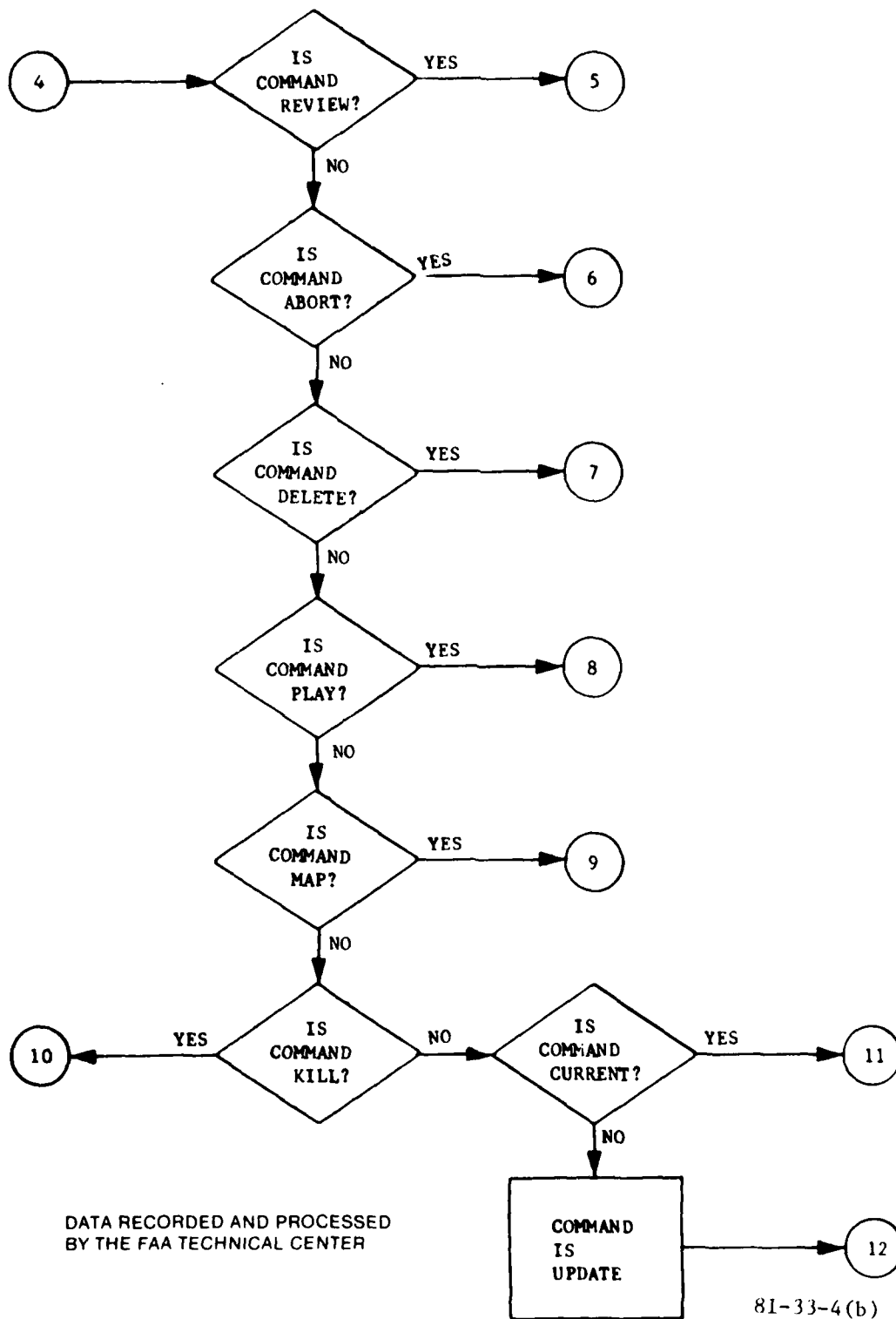

FIGURE 4. MANUAL VOICE INPUT SUBSYSTEM FLOW DIAGRAM (2 of 11)

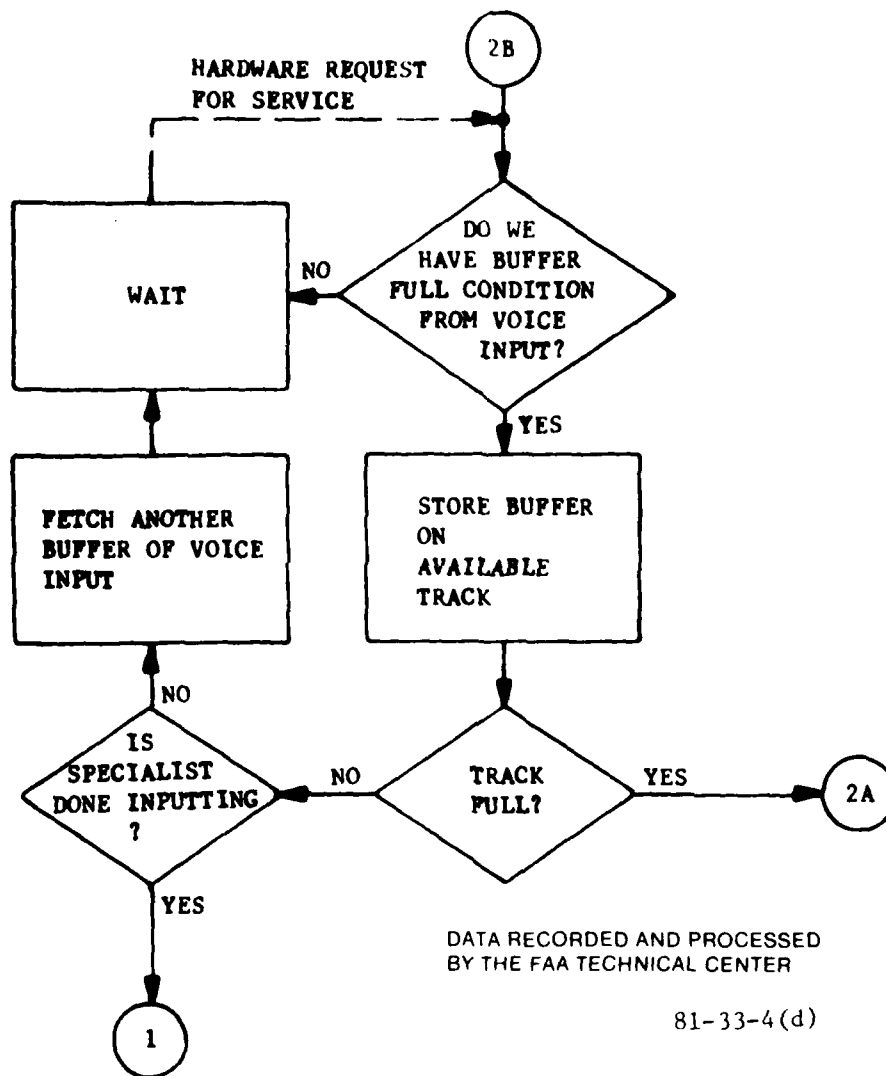
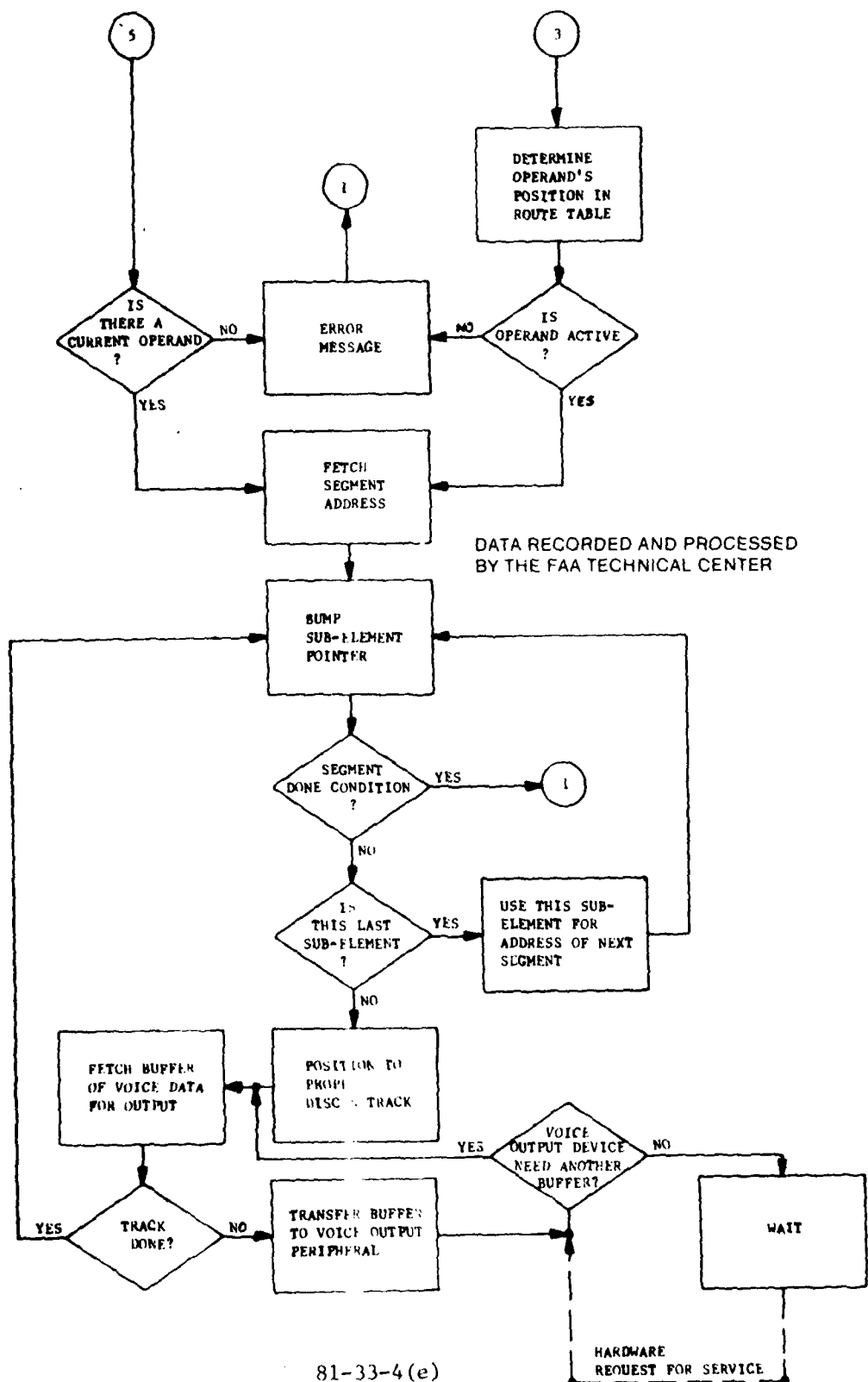
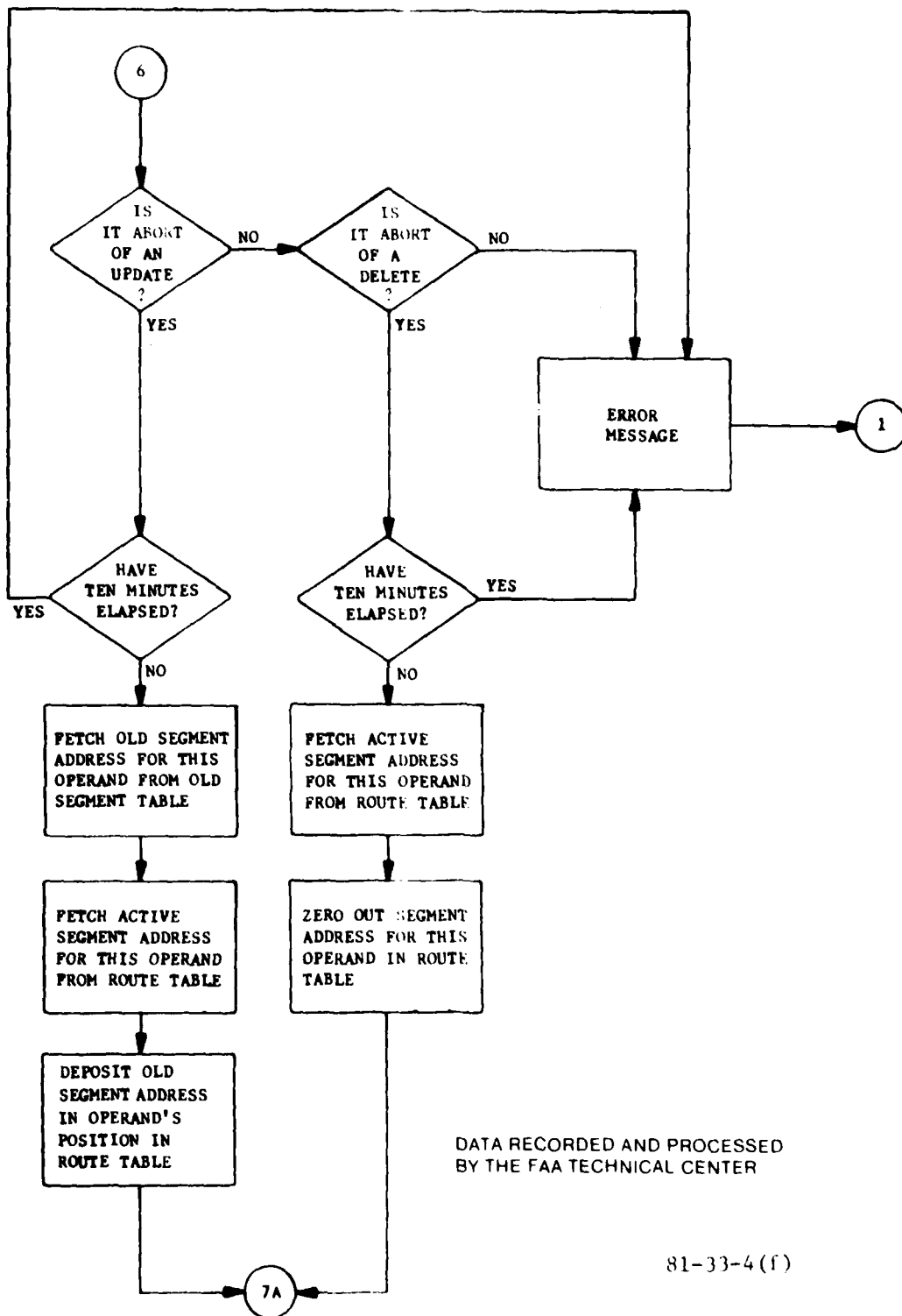

FIGURE 4. MANUAL VOICE INPUT SUBSYSTEM FLOW DIAGRAM (4 of 11)



81-33-4(e)

FIGURE 4. MANUAL VOICE INPUT SUBSYSTEM FLOW DIAGRAM (5 of 11)



81-33-4 (f)

FIGURE 4. MANUAL VOICE INPUT SUBSYSTEM FLOW DIAGRAM (6 of 11)

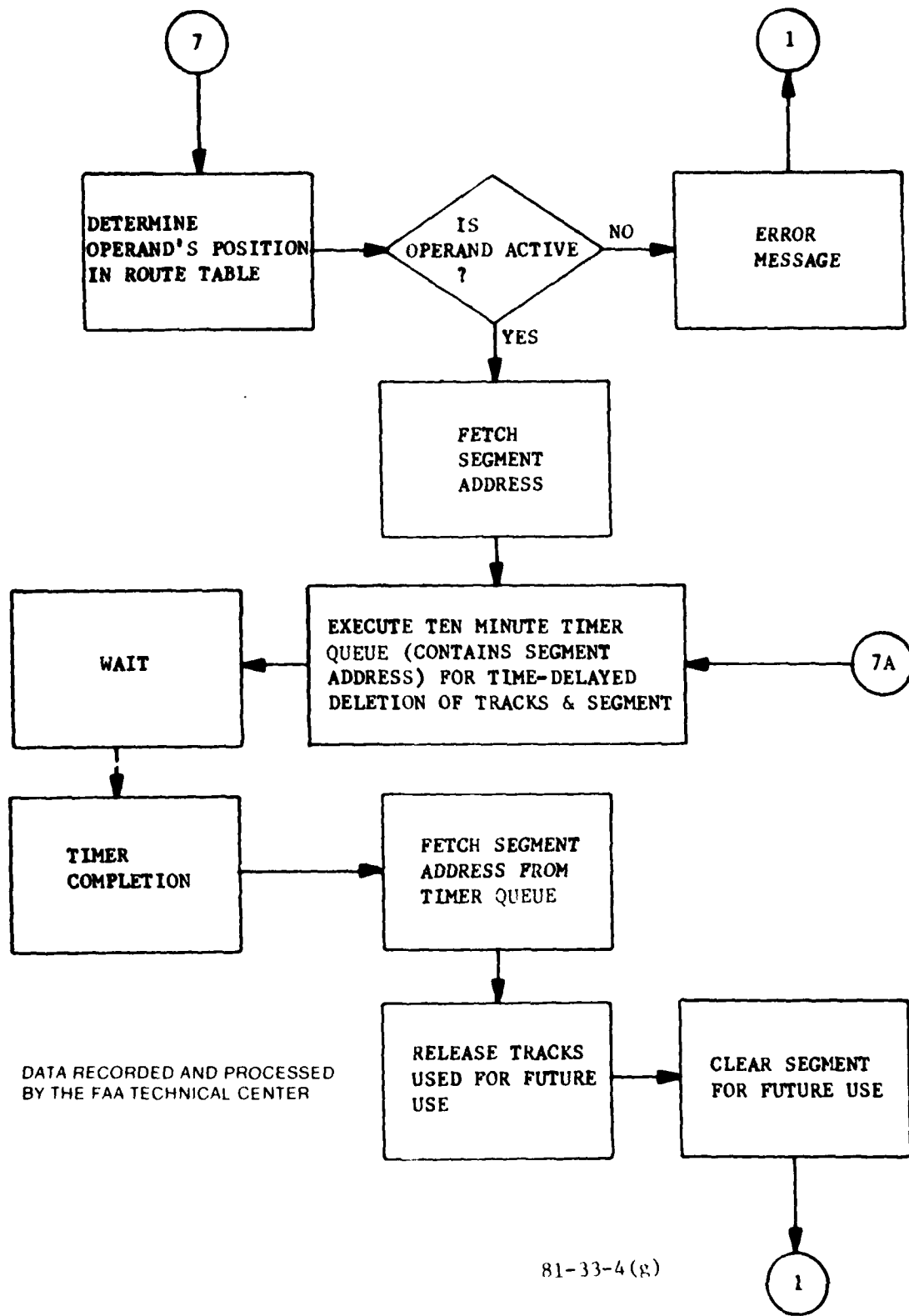

FIGURE 4. MANUAL VOICE INPUT SUBSYSTEM FLOW DIAGRAM (7 of 11)

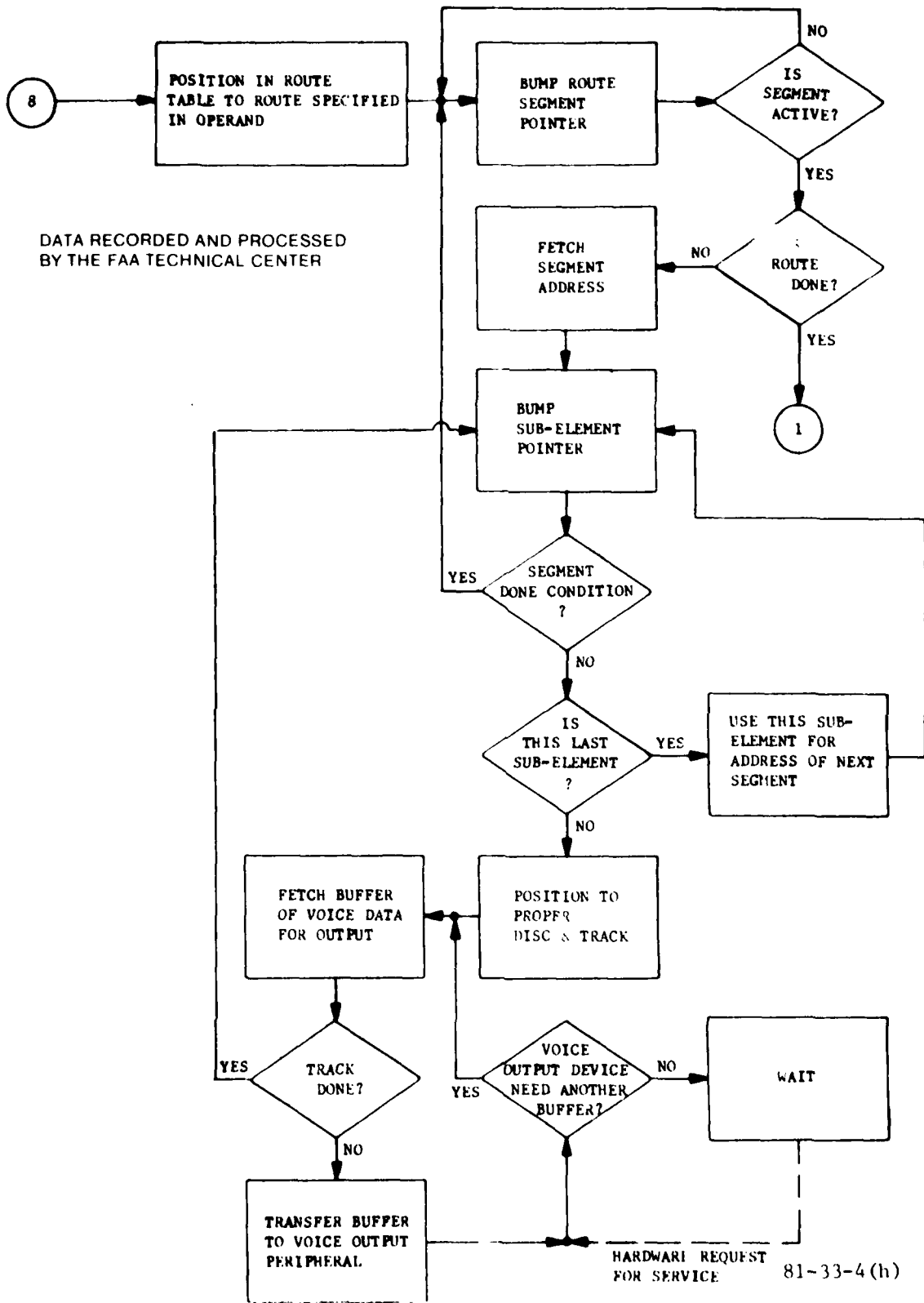

FIGURE 4. MANUAL VOICE INPUT SUBSYSTEM FLOW DIAGRAM (8 of 11)

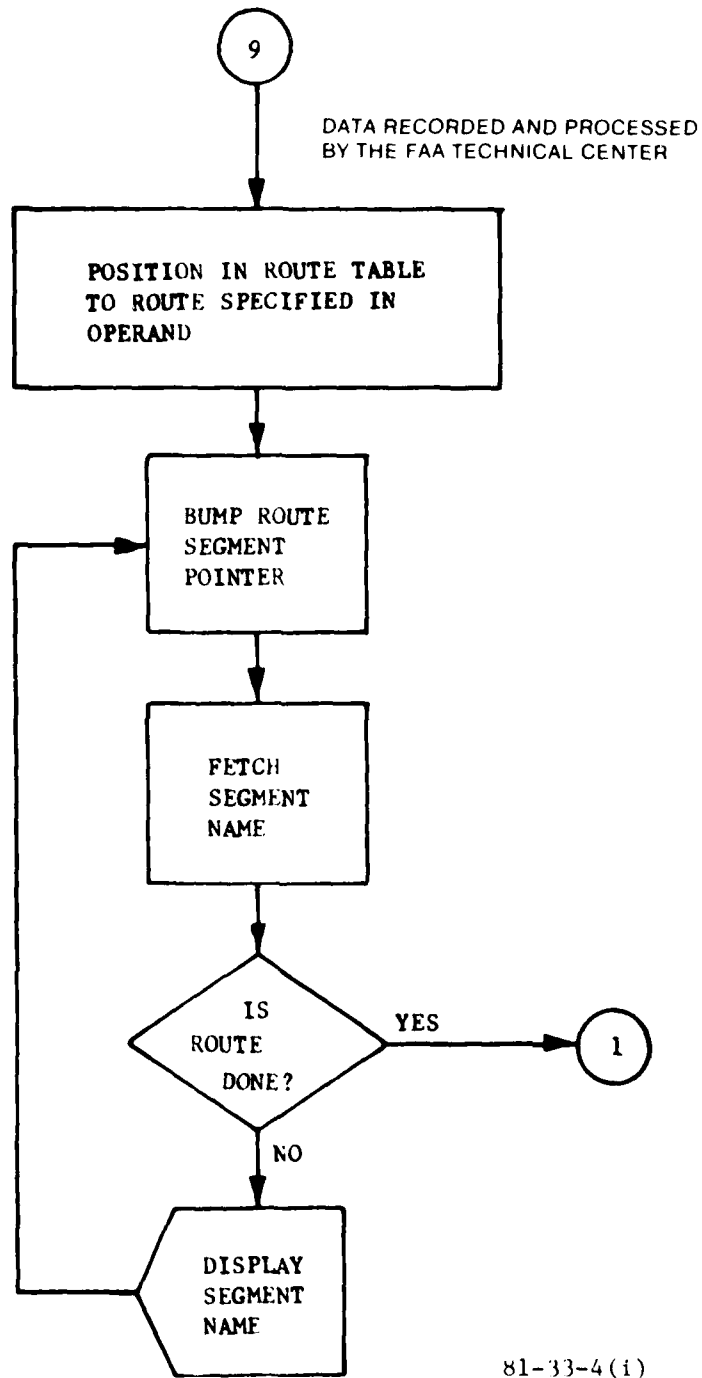
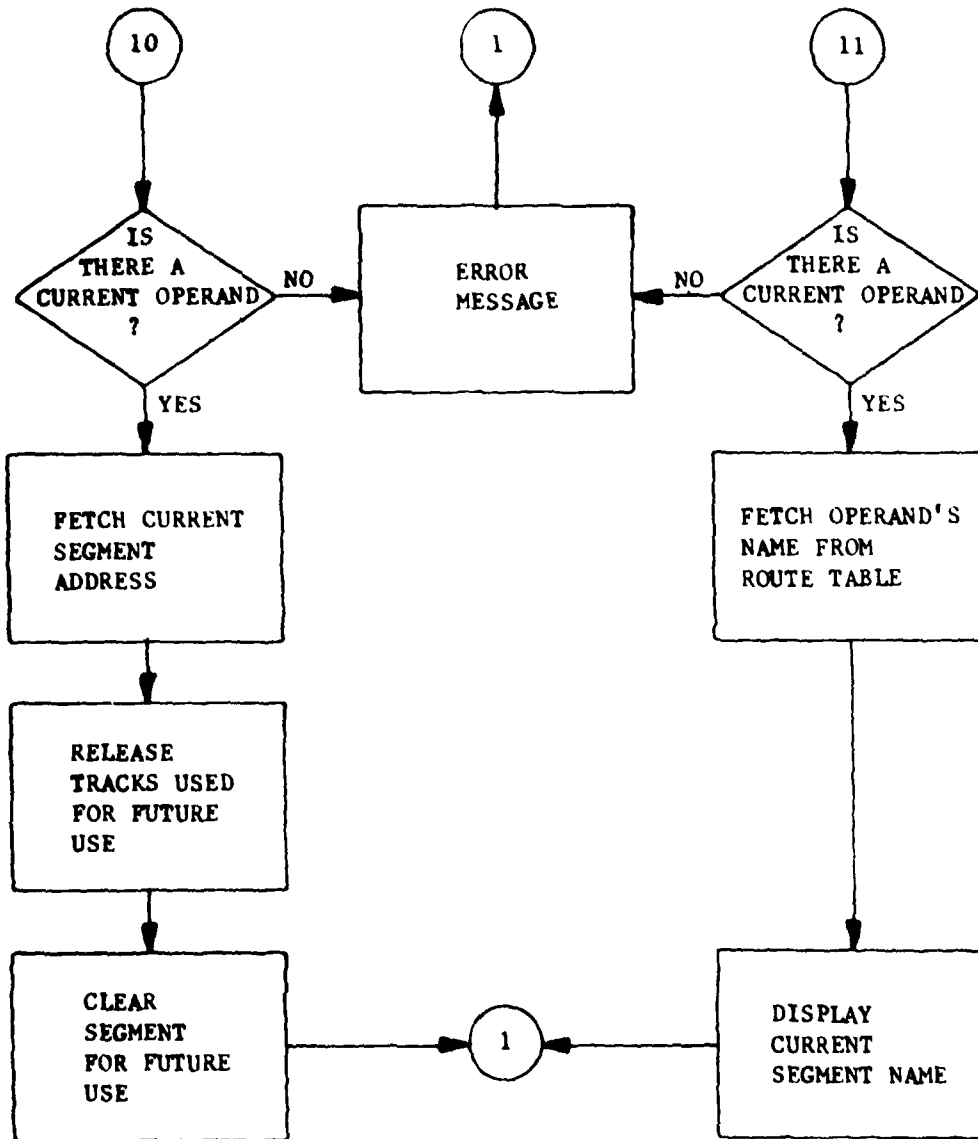

FIGURE 4. MANUAL VOICE INPUT SUBSYSTEM FLOW DIAGRAM (9 of 11)

DATA RECORDED AND PROCESSED
BY THE FAA TECHNICAL CENTER



81-33-4(j)

FIGURE 4. MANUAL VOICE INPUT SUBSYSTEM FLOW DIAGRAM (10 of 11)

DATA RECORDED AND PROCESSED
BY THE FAA TECHNICAL CENTER

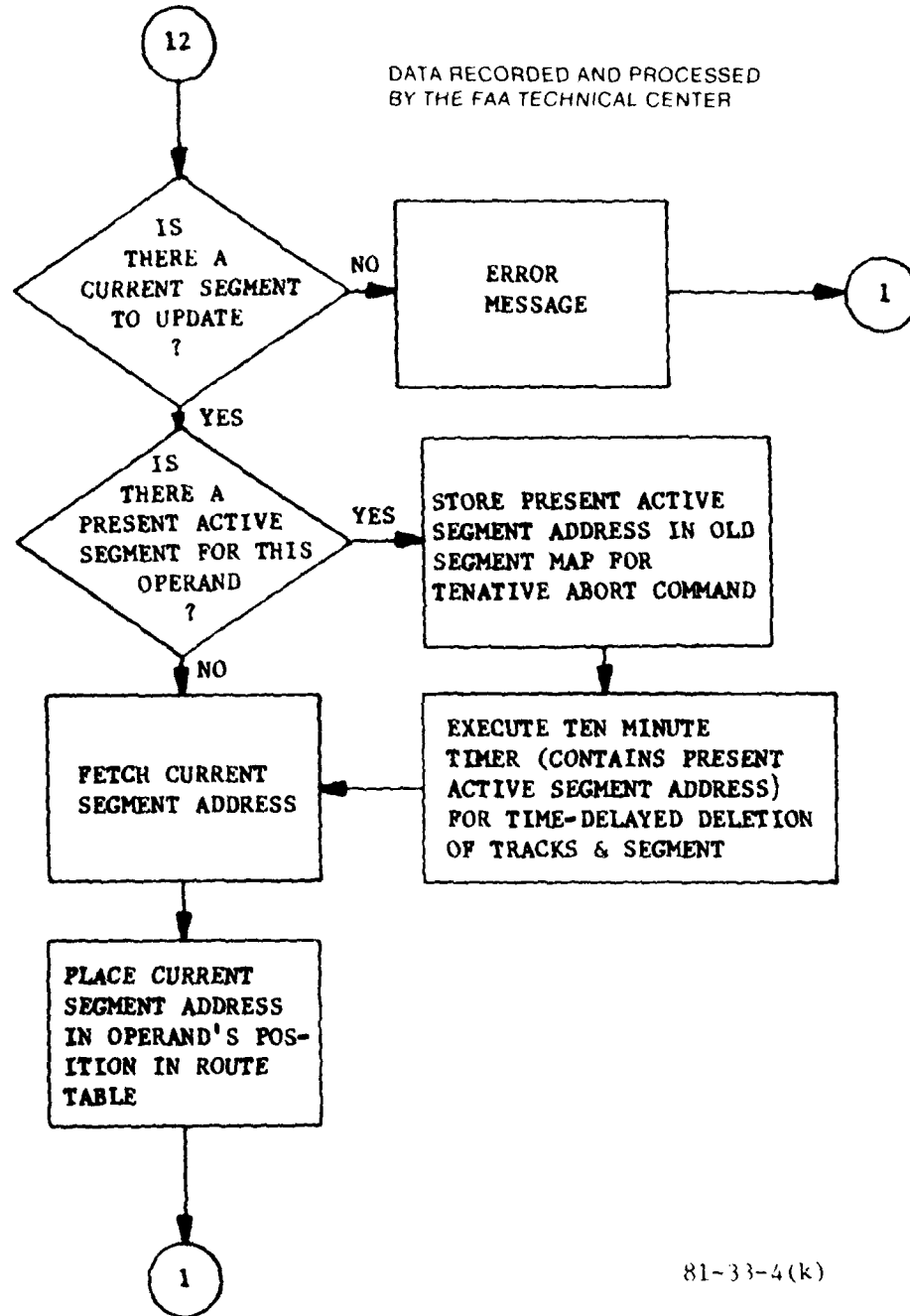

81-33-4(k)

FIGURE 4. MANUAL VOICE INPUT SUBSYSTEM FLOW DIAGRAM (11 of 11)

typed on the keyboard, by the specialist, and if both parameters were valid it would present the northbound route map on the specialist's CRT display which would show the currently active segments in this specific route briefing.

The specialist at this time may want to "listen" to this "FT" segment to confirm that the information being disseminated is not current. If the command and operand are valid, the algorithm checks to see if the segment is active and, if so, fetches the segment address. The segment is disseminated to the specialist's position, a track at a time, until the "segment done" condition is detected, at which time the specialist can enter his next command for the system to execute.

The specialist, at this time, would now "talk" the current "FT" segment into the system. The algorithm would seek out available tracks, as needed, to enter the new message segment into the system. The specialist enters a carriage return at his keyboard when he is done inputting, which thus allows a segment to be of any duration, with the only limitation being the storage capacity of the system.

Upon completion of this "talk" operation, the segment just entered can be reviewed for content accuracy and speech clarity, by entering a "review" command and the appropriate segment name. If the specialist is satisfied with the new message segment, he would "update" the "FT" segment into the system. The next caller that requests the northbound briefing would now receive this new "FT" segment as part of the message presentation.

For the sake of discussion, let us assume that the specialist discovers that he entered the wrong information for the "FT" segment. Assuming 10 minutes have not elapsed since the "update" operation, the specialist can reverse the procedure via use of an "abort" operation. By entering an "abort" command accompanied with the appropriate segment name, the current "FT" segment is deleted from the system and the old "FT" segment again becomes the current "FT" segment for the northbound briefing. If an "abort" command is not received in 10 minutes for an "update" command, the old segment is deleted from the system at the end of the time interval.

Other operations performed by the specialist from this position would follow similar flow paths through the logic diagrams. This facet of the software package was designed with a "single-thread" mode of operation to try and reduce to a minimum the possibility of erroneous data being entered into the system.

The interrelationship of the tasks and devices can be ascertained by referring to figure 5.

FUNCTIONAL DESCRIPTION OF SYSTEM TASKS AND DEVICES.

The three tasks described in the following paragraphs constitute the position at which the five route-oriented briefings, which are composed of a number of SUBELEMENTS called segments, can be monitored and new message segments may be generated to keep the briefings current with the latest weather data available. Many safeguards have been incorporated into the software to minimize the entry of improper information or the deletion of current information prematurely. Among these safeguards are the restriction of only speaking a valid "segment name" and the further restraint of single-threading the operations involved in making the

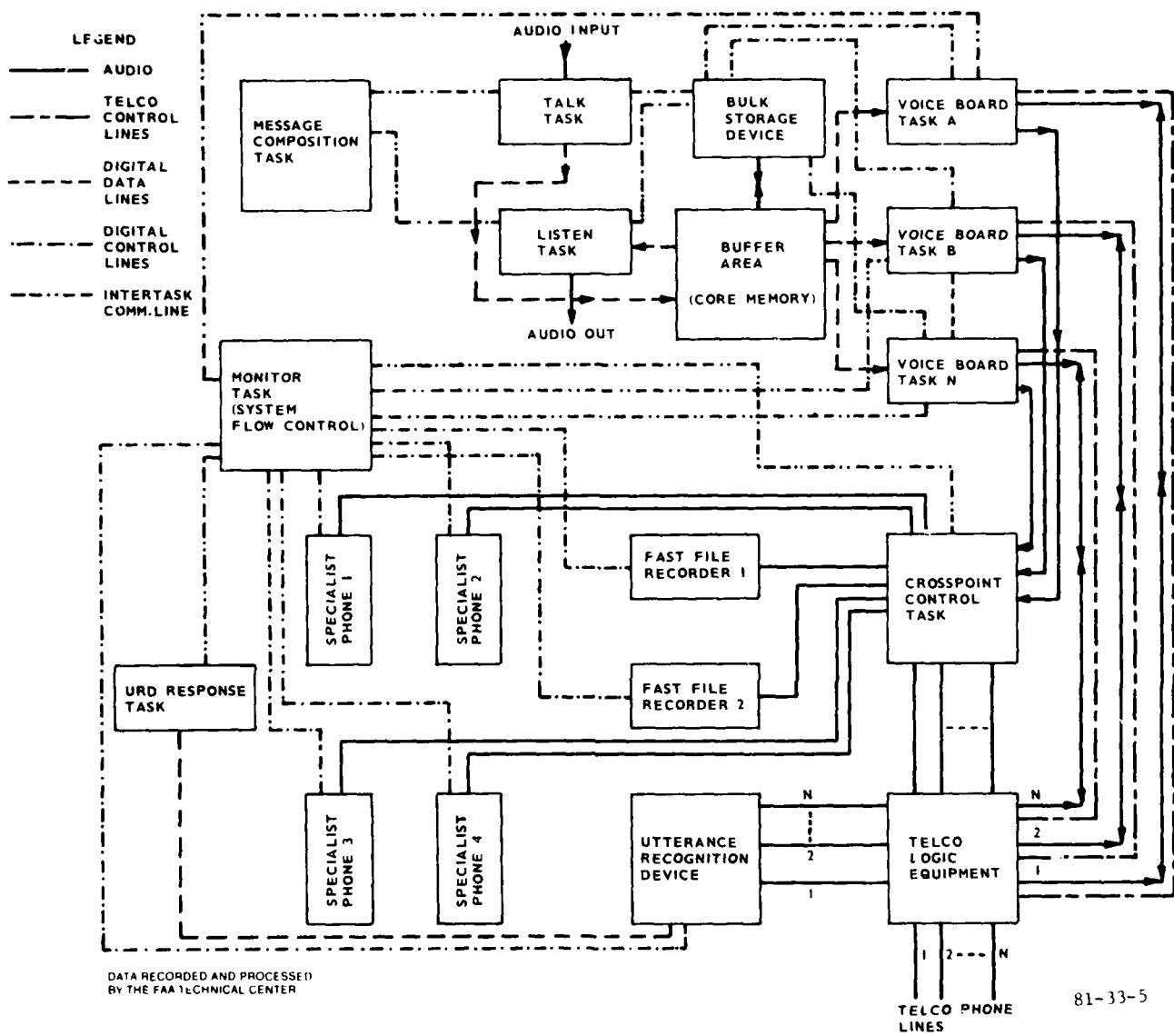

FIGURE 5. FUNCTIONAL BLOCK DIAGRAM OF SYSTEM SOFTWARE

segment available to the pilot. An example of this is the fact that the specialist either has to "kill" or update a "talked" segment before the system will accept a new segment. In this manner, it is hoped to keep the specialist cognizant at all times of the functions he is performing. Other safeguards will be described in the following discussion.

MESSAGE COMPOSITION TASK. The message composition task incorporates the software necessary for the specialist to monitor, delete, and update any of the message segments which constitute the content of the five route-oriented briefings available to the pilot in the system. Since this task has no time-critical queues associated with it, it has a lower system priority than those tasks that have such time-critical queues associated with them. This task's functions are performed totally asynchronous with respect to system services being delivered to pilots utilizing the system.

The specialist can listen to any segment currently active in the system to verify validity of message content and speech quality. He also has the ability to play a whole message in context to check for completeness of information content and continuity of material presented. Finally, the specialist has the option to review a message segment just spoken, to assure proper digitalization of analog signal, confirm information content and speech quality before making this segment available to the public via the system. All the above functions are conveyed via a supervisory call (SVC) 6 intertask communication system function to the listen task.

Another function available to the specialist is the ability to "talk" a new segment into the system. When the specialist receives updated information to be entered, he simply types the command word "talk" and a valid "segment name" operand. This causes an SVC 6 intertask communication to take place between the message composition task and the talk task, whose functions will be described later.

A delete function also exists in the software to allow the specialist to remove segments in the system which are no longer current but have no update to replace them. This deletion is time delayed so that any users which are currently accessing the now deleted segment will be able to finish listening to the content of this segment; however, any new users to the system will no longer be able to access this segment when listening to the route in which it was formally active.

The update command allows the specialist to make a newly spoken segment available to the pilot after the specialist has reviewed the segment for correct information content and speech clarity.

The abort command allows for the reversal of either an update or delete command. In both cases, the abort capability is valid for a period of 10 minutes from the issuance of either the update or delete command. If the abort is being executed on behalf of a delete command, the "segment name" is checked to see if an old segment exists and if 10 minutes have not elapsed, allows the abortion to execute making the old deleted segment again the current active segment. In the case of an update command, the abortion replaces the updated message segment with the old saved segment, if it exists, and deletes the update. This function's primary use is the ability to recover from the entry of an improper update or delete command into the system.

Two additional commands that should be noted are the "current" and "kill" commands. Both of these functions are applicable to a spoken segment that has not been updated into the system for a pilot's listening enjoyment. The "current" command allows the specialist to obtain the name of a segment, if one exists, that has been spoken into the system, but not updated. The "kill" command allows the specialist to delete a "talked" segment that he deems invalid for entry into the system as part of the briefing.

LISTEN TASK. The listen task is the means by which the system conveys audio information to the specialist upon his request. The reason this task is not part of the composition task software is due to the fact that the interrupts being generated to produce audio for the specialist are time-critical in nature. This fact mandates that the priority of the task receiving these time-critical queues be of equivalent priority to other tasks in the system which have to respond in a timely manner to queues from the operating system environment in which they reside.

The listen task responds to an SVC 6 intertask communication from the message composition task which conveys, in coded form, the name of the segment the specialist wishes to review. The task software then obtains the appropriate track information from the segment block and disseminates these tracks in a sequential manner to the audio board servicing the specialist. Upon completion of the last track in the segment, the listen task sends a communication back to the message composition task, taking this task out of its dormant wait state, now able to accept further commands from the specialist. After completing this operation, the listen task executes an SVC 9, putting itself in a wait state with traps enabled for another communication from the message composition task when the specialist requires further segments to be audited.

TALK TASK. The talk task is the mechanism which increases the specialist's priority in the system when he is speaking new information into the system for dissemination to the pilot. This task is removed from a wait-state condition with the reception of an SVC 6 communication from the message composition task. This message conveys coded information on what name the segment will be associated with in the system if it is made an active segment.

This task finds an available track on the storage media, and as buffers of binary coded audio information are generated by the audio input board, they are stored on the track. When this track is filled, another free track is sought and the process is repeated. This track information is formed into a binary word and stored in an available segment block for future access by the system for dissemination purposes. This process continues until either the specialist indicates he is done via the keyboard at his position or all available storage is allocated, at which time a message would be sent to the specialist telling him that some segments have to be deleted from the system before a new segment can be generated.

As the task finds available tracks in the track maps for the five storage media, it sets the appropriate bit in the track map as it utilizes them for the segment being newly generated. These tracks remain dedicated to this segment until it is deleted from the system. This task, upon reception of the completion signal from the specialist, relinquishes control back to the message composition task; at the same time, the task puts itself in a wait-state with traps enabled to await the next request by the specialist to speak a new segment of current weather data.

It is evident from the above discussion that the three tasks that comprise the message entry position of the system gives the specialist all the tools necessary to review, generate, and replace any segment within the system that makeup the route-oriented briefings. Also incorporated into the software are many safeguards to protect the integrity of the segments making up the system route-oriented briefings. Additional protection is obtained by the single-threading nature of operations that the specialist has to go through to enter new weather information into the system for dissemination to the pilot.

VOICE BOARD TASK.

The voice board task is the interfacing mechanism between pilot and system. Since time-critical queues are being generated by the voice boards, this task has to have a higher system priority to provide timely servicing of the system queues to the task in order to obtain uninterrupted voice output from the board. The software incorporated in this task provides all the logic necessary to present system statements, questions, and route-oriented briefings to the pilot, the flow depending on options he has requested of the system.

When the pilot accesses the system, his call is intercepted by the Telco equipment which routes the caller to an available voice board in the system. The Telco equipment, via an array of control lines, activates a ring detect signal on the voice board which causes the board to generate a hardware interrupt that the system intercepts and converts into a system queue that is sent to the task associated with this voice board. Upon reception of this system queue, the task software accesses the segment block associated with the system preamble and disseminates this introduction to the pilot. Upon completion of this statement, the task sends an SVC 6 intertask communication to the monitor control task; the content of this communication contains both the task/board identification and coded information on which route-oriented briefing or system message was just disseminated to the pilot. This task also incorporates the logic to decide if it is disseminating a system question or a briefing. If it is a briefing that is being disseminated, the task automatically plays the entire briefing before notifying the monitor task of completion of this transaction. The monitor task is the control entity on what the voice board will next disseminate to the pilot.

CROSSPOINT CONTROL TASK. The crosspoint control task is an executive task that was developed to communicate with a controller designed and built in-house to operate a crosspoint switch array. This array was needed to do the audio switching of Telco phone lines to system utilities; i.e., specialist handsets and fast-file recorders. This task receives information on what commands to send to the crosspoint controller from the monitor control task via SVC 6 intertask communication.

An executive task is one that can execute input/output (I/O) type instructions which allowed it to communicate with the crosspoint controller directly, rather than using the system as an intermediary, as is the case with user tasks. The advantage of this approach was that a driver did not have to be developed for the crosspoint controller, thus making the implementation of this function into the system a much more expeditious procedure. The main disadvantage in using an executive task is that a piece of hardware, called a memory access and protect controller (MAC) in the Interdata 7/32, is off when an executive task is active. This device provides automatic memory relocation which allows a user's task to be loaded anywhere in available memory and appear to be located at absolute zero. The MAC also provides memory protection that prohibits a user from accessing memory outside of the task's memory partition. With the features described above not available in an executive task, much care must be exercised in writing such a task so that it does not vector out of its valid memory area and destroy part of the operating system software.

The monitor control task, depending on options specified by a pilot, would assemble the appropriate command that will cause the proper audio linkage to be established when executed by the crosspoint controller. This command is sent via an SVC 6

communication from the monitor control task to the crosspoint control task, at which time the command is executed by the controller and the audio link is established. When the pilot is finished using this system utility, the monitor task sends a disconnect command to the crosspoint control task which in turn, talks to the crosspoint controller and the audio link between the pilot's phone line and the utility is broken. In this manner, audio linkages can be established and broken from any phone line to any utility in the system, depending on the pilot's utilization of the system.

UTTERANCE RECOGNITION DEVICE (URD) RESPONSE TASK. The URD response task is responsible for receiving the communications from the URD. Among the types of communications encountered on the RS-232 asynchronous line that the task is monitoring from the URD are answers to interpret commands and acknowledgements to commands sent to the URD via the monitor control task; i.e., connects, disconnects, and interprets.

The URD response task has the highest priority of any task in the system. The reason for this high priority is to assure immediate response to the completion of a message from the URD and execute another read operation on the asynchronous line as expeditiously as possible. This immediate action is required to avoid the possibility of a lost or broken message from the URD. The reason this possibility exists is because as the system becomes fully utilized, the computer has less free time and the monitoring of the RS-232 line from the URD could degrade appreciably as the computer is servicing the 20-voice lines with data. Since the monitor control task is sending commands to the eight-channel device and the computer and device are operating asynchronously with respect to each other, messages accumulate in a message queue list in the device pending transmission to the computer. Since the list capacity is small, it is seen that unless timely service is given the communication line, a message overflow condition exists which would result in lost or garbled messages. This condition would be highly undesirable, since system flows depends on these answers to service the pilot.

The result of this phenomenon would be that the pilot would become hung-up in the system along with system resources involved in this transaction being suspended from further use in the system. In order to further expedite the monitoring of this line, the task makes no decisions on the answers sent by the URD; but instead, conveys this information to the monitor control task which analyses the answer at a lower system priority; it can then be interrupted when something of more importance requires system attention. Using this technique, it is hoped to minimize the possibility of a message queue list overflow condition from occurring in the URD.

MONITOR CONTROL TASK. The monitor control task (MCT) is the controlling element of the mass weather dissemination system exploratory engineering model. This task is event driven and only responds to system queues entered on its task queue list. In the following paragraphs, a description of the subfunctions that this task performs are discussed.

URD Communication Function. Whenever the system requires the recognition of a spoken word from the pilot, the URD must be utilized to accomplish this goal. Since the system design specified servicing 20 phone lines simultaneously and the URD is an 8-channel device, it is evident that an URD channel could not be dedicated to a phone line, but that multiplexing of the 8 URD channels to the 20 phone lines was necessary. When a voice board task alerts the MCT of completion of a

system question, it extracts the phone line information from the communication received from the voice board task. The MCT also maintains a record of URD channel utilization and thus knows if one is available.

If a URD channel is available, the MCT changes the channel's status to busy during the duration of the interchange between pilot and URD. The MCT then assembles a connect command containing the information on the phone line and URD channel to be connected in the audio domain. This command is transmitted to the URD via an RS-232 line and upon reception of this command, the URD will perform the appropriate crosspoint connection internally and echo the command back to the system. This command echo is utilized to assure that both nongarbled transmission was achieved and that the appropriate action had been performed. If a channel is not available, the pilot is placed on a wait list until a URD channel becomes available. The information placed in this list contains both the phone line identification and the question just asked of the pilot.

Upon reception of the connect command echo, the MCT starts to assemble an interpret command. Since increased recognition ability is obtained if the URD is limited to a subset of its total vocabulary, the words needed to obtain any system service have been broken down into these smaller sets; each of which encompass all the words needed for that particular option. The interpret command is then assembled with the appropriate URD channel and subgroup code derived from the question just asked of the pilot. The URD will again echo back this command.

One of three possible responses can be expected from the issuance of an interpret command. Two of these responses are the time-out and not understood codes. Both of these possibilities are handled the same way by the MCT, which is to tell the voice board task to play an appropriate "repeat options" question along with an explanatory statement that the computer did not understand him and to please try again. If this phenomenon happens a second time, the MCT tells the appropriate voice board to play a statement indicating that the computer cannot understand the pilot and to standby for a specialist who will assist him with his call. The last possible response is the answer to the question played to the pilot. The MCT can then take the appropriate action, depending on the answer obtained.

When either the second time-out/not understood codes or the answer is obtained, the MCT assembles a disconnect command containing the appropriate phone line and URD channel information. This command is sent to the URD, at which time the URD internally does a crosspoint operation to disconnect its channel from the phone line and then echos the command back to the MCT via the system. The MCT, upon reception of this disconnect command echo, then makes this URD channel available for use and checks to see if any pilots are on the wait list before going into a quiescent condition. If a pilot were on the wait list, he would be removed from the list and a connect command would be assembled and sent to the URD before the task became inactive.

The MCT also maintains a list of commands sent to the URD but not yet responded to by this device. If the URD, for any reason, does not understand a command, it sends an ASCII question mark on the RS-232 line in response to this command. This means that one of the commands on the command list has not been executed, which will result in a "hung-up" condition for one of the pilots using

the system. Since it would be highly undesirable to reissue commands that have been implemented, a technique had to be developed to ascertain which command needs to be sent again due to either a broken or garbled original transmission.

Upon reception of a question mark from the URD, an immediate transfer of all the commands in the command list to a "bad" command list is executed, since one of these commands is the one that was not understood. As the URD now sends echos of other commands sent to it, the MCT does a match of this command with commands on both command lists. When a match is found, that command is removed from the list, and in the case of the "bad" command list, when one command entry remains, it can be removed from the "bad" command list and reissued to the URD, since it is obviously the command that the URD did not receive properly on the first transmission.

From the above discussion, it is seen that great care has been exercised to assure no lost transmission on the RS-232 asynchronous communication line between the URD and computer. This approach is mandatory, since system flow depends completely on answers given by the pilot in response to system questions as interpreted by the URD.

Route-Oriented Briefing Function. When a voice board communicates to the MCT that it has just completed playing the system options question to the pilot, the MCT goes through the URD communication function described above, placing the "options" subgroup code in the interpret command. If the answer is "briefing," the MCT tells the voice board task to disseminate the system question concerning what routeoriented briefing the pilot would like. Another URD iteration is performed, this time placing the "routes" subgroup code in the interpret command. When an answer is obtained, for example, "north," the MCT conveys this information to the voice board task at which time the desired briefing is disseminated to the pilot. At the conclusion of the briefing, the voice board task also disseminates a system question asking the pilot if the system can be of any further assistance to him. After this question is done, the voice board task alerts the MCT of this fact and another URD iteration is performed, this time the subgroup code selected looks for a "yes/no" response. If the answer is "yes," the MCT tells the voice board task to play the "options" question to the pilot and if the answer is "no," the MCT tells the voice board task to play a complimentary closing statement to the pilot and then terminate the transaction by a phone line disconnect. This voice board is then available for use by another pilot requiring assistance from the system.

Specialist Function. The specialist function is encountered by the pilot in one of two ways. He can be handed off to a specialist by the MCT if (1) the URD has continued difficulty in understanding what he is saying, or (2) the pilot says the word "specialist" at the conclusion of the "system options" question.

In either case, the MCT follows the same algorithm to accomplish the connection of the pilot to the specialist. The MCT maintains a record of availability of the four specialist positions contained within the system. The specialist positions initially come up in an unavailable state and become available when the specialist switches his on-line/off-line switch on his handset to the on-line position. This switch is constantly monitored, thus allowing the specialist to change the status of his position as mandated by his functional priorities in the FSS. In the event a specialist position is not available, the pilot is put on

a specialist wait list until such time that either a position changes its status to on-line or a position becomes available at the conclusion of a previous connection to this position.

If a position is available, the MCT issues a ring command to that position and then monitors this position for one of two possible responses. The first possible response is a pickup code transmitted from the handset telling the MCT that the specialist has picked up his instrument. Upon reception of this code, the MCT assembles a command for the crosspoint control task containing information of phone line identification and the available specialist position. The crosspoint control task conveys this information to the crosspoint controller which performs the operation that makes the audio link between these two system entities. The MCT also changes the status of this specialist position to busy status conditions for the duration of the conversation between pilot and specialist.

The second possibility is that the specialist decides he has a higher priority function to perform and instead of picking up his instrument he takes his handset off-line. When the MCT receives this code from the handset, it changes this specialist position's status to unavailable and looks for an alternate position for the pilot, who is still waiting to be serviced by a specialist. If one is found, a ring command is sent to that handset in order to satisfy the pilot's request. If no position is found, the pilot is put on the specialist wait list until one becomes available.

At the conclusion of the conversation between pilot and specialist, the specialist has one of two possible actions he can perform.

1. He can hang up his instrument, which then transmits a hang-up code to the MCT that causes the task to do a number of operations. The MCT assembles a disconnect command to be sent to the crosspoint control task to break the audio link between the position and phone line. It also communicates to the voice board task to disseminate the system question pertaining to being of further assistance to the pilot. Finally, the MCT makes the position available and checks to see if any pilots are on the specialist wait list and if so, will remove the pilot from the wait list and issue a ring command to this now available position, before becoming inactive.

2. The second action is to go off-line before he hangs up his instrument. When the MCT detects this condition it does the following conditions. It still issues a disconnect command to the crosspoint control task and tells the voice board task to disseminate the "further assistance" question. Finally, it changes the status of the position to unavailable and then goes into a wait state condition.

The algorithm described above is basically a software version of an automatic call director that can be obtained from the telephone company. Incorporated in the software, however, are some features that would be hard to get as options on such a system, plus the increased adaptability for change gained in the software approach, both of which were deemed as valuable attributes to the system design.

Fast File Function. The pilot is directed to the fast-file recorder whenever he says one of the three system options words, "file," "amend," or "close." The MCT maintains a record of availability of the two fast-file recorders incorporated in the mass weather dissemination system exploratory engineering model.

After completion of the "system options" question and the appropriate commands have been sent to the URD by the MCT and the word "file" has been interpreted by the URD and sent back to the MCT, the following actions are taken as described in the text that follows. If neither of the two fast-file recorders are available, the pilot is put on a fast-file wait list until one of the units becomes available.

If a fast-file recorder is available, the MCT will tell the voice board task to play the system statement providing instructions on how to use the fast-file recorder and also assembles a command for the crosspoint control task to establish the audio link between the system utility and the pilot's phone line. At the conclusion of the fast-file instructions, the voice board task alerts the MCT of this fact and sends a "record" command to the fast-file recorder. The MCT changes this recorder's status to busy for the duration of interchange between pilot and system and the task then goes into a wait state until one of two possible responses is returned from the recorder.

One possible response is a "jam" code. If the MCT receives this code, it changes the status of that recorder to unavailable and assembles a command for the crosspoint control task to do an audio link disconnect between the pilot's phone line and the fast-file recorder. The MCT then tells the voice board task to play the statement that explains to the pilot that the fast-file recorder has jammed and to standby for a specialist who will assist him with his filing of a flight plan. The statement also requests that the pilot alert the specialist to the fact that a recorder is jammed so that remedial action can be taken.

The other possible response from the recorder is a "record done" code which when received by the MCT causes it to tell the voice board task to play the system question, which asks if the pilot would like to review his flight plan. At the conclusion of this question, the MCT does a URD command iteration with the yes/no subgroup code placed in the interpret command.

If the pilot's answer is "no," the MCT sends an "unseize" command to the fast-file recorder. This command causes the recorder to write a file mark on the tape which protects the flight plan preceding it from being further accessed and also causes the recorder to become available for another flight plan. The MCT assembles a command for the crosspoint control task to break the audio link between the two system entities and also tells the voice board task to play the "further assistance" question to the pilot. Finally, before the MCT becomes quiescent, it checks to see if any pilot is on the fast-file wait list and if so, removes the pilot from the wait list and proceeds as described earlier when a fast-file recorder is available.

If the pilot's answer is "yes," the MCT sends a "rewind/play" command to the recorder. The recorder then rewinds to a file mark which constitutes this pilot's flight plan and then plays the flight plan back to the pilot on the already existing audio link. At the end of this process, the recorder notifies the MCT of the fact that it is done, at which time the MCT tells the voice board task to disseminate the system question concerning whether the pilot wishes to make amendments to his flight plan. If the pilot's answer is "no," a similar process, as described for a negative response to reviewing his flight plan, is executed.

If the pilot's answer is "yes" to this question, the MCT sends a "write file mark" command to the fast-file recorder to segregate the pilot's flight plan from

his amendments; this is done in case the pilot wants to review his amendments after he has entered them. The MCT also tells the voice board task to tell the pilot to standby to speak his flight plan amendments immediately after the queue tone. At the end of this statement, the MCT sends a "record" command to the fast-file recorder. When the fast-file recorder alerts the MCT that this process is completed, the MCT tells the voice board task to disseminate the question asking the pilot if he wishes to review his flight plan amendments. If the pilot's answer is "no," it is handled as described above for a negative response to fast-file review questions. If the pilot's answer is "yes," it is handled in the same manner as an affirmative response to making flight plan amendments. This procedure of making amendments can be repeated until the pilot is satisfied with the information contained in his flight plan and additional amendments.

If the pilot says "amend," the MCT algorithm is similar to the amend algorithm described earlier when the pilot amends his flight plan immediately after speaking it. If the pilot says "close" in response to the "options" system question, the access procedure that the MCT uses to obtain a fast-file recorder for the pilot is the same as described earlier. The main differences are that the MCT tells the voice board task to play the statement that the pilot may speak his flight plan closure immediately after the queue tone and no provisions are made to allow the pilot to review his flight plan closure. Instead, the MCT sends an "unseize" command to the fast-file recorder, tells the voice board task to play the "further assistance" question and sends a command to the crosspoint control task to do an audio disconnect between the recorder and phone line. The MCT then changes the recorder's status to available and checks the fast-file wait list to see if any pilots in the system are waiting for a fast-file utility. If there is a pilot on the wait list, the MCT would remove the pilot from the wait list and go through the necessary procedures to connect the pilot to this system utility.

CONCLUSIONS

The following major conclusions have been drawn as a result of developing the mass weather dissemination exploratory engineering model.

1. The engineering model demonstrated that synchronous access of a message was feasible for multiple users via use of a fast retrieval storage device (fixed head discs) and a minicomputer.
2. The model showed that message-to-line multiplexing was achievable by using an untrained utterance recognition device (URD) and a processor to take appropriate action on the answers obtained from the recognition device.
3. It was shown that timely message segment updating was possible with no interruption of service to users of the system.
4. The file management technique developed and employed in the system, induced the minimum amount of overhead and obtained maximum utilization of the storage media.
5. Timing measurements were made on system overhead generated per audio output channel. The experiment showed that approximately 6 percent of the system's total time was needed to service an audio output board. The experiment was done with

eight audio output channels running simultaneously. It is seen from this data that 15 channels could be nominally serviced simultaneously by the system, assuming linearity in system overhead per channel in the extrapolation process.

6. The model proved that other options could be obtained with a one-call access of the system. One of these options was the ability to switch a caller to a specialist handset upon request. This was done via use of the URD and a crosspoint switch array/controller, with the minicomputer controlling these devices appropriately, by utterance of the word "specialist" from the caller.

7. It was shown that a software counterpart of a hardware automatic call distributor functioned well in the engineering model. Along with the ability of a ring-down feature for an available handset, the specialist also had the capability to go off-line, upon reception of a ring condition, if a more urgent task was pending. The system, sensing this condition, would find the caller another available position, or if none were found would put the caller on a wait list until a position became available.

8. A final option available to the caller upon request is the ability to file a flight plan on a digitally controlled analog tape recorder. By speaking one of the words "file," "amend," or "close," the system switches the pilot's audio line to an available fast-file recorder, via the crosspoint switch array/controller. The pilot also has the choice of reviewing any information he has entered on the recorder, for content clarity and validity. The advantage of this option is to provide expeditious service to the pilot and off-load the specialist during peak loading times of the system.

9. System startup and diagnostics are one-word entries at the command console. This feature is available because of the power embedded in the operational software of the system. One of these features is a command substitution system (CSS) which executes multiple system commands by entry of a one-word command. This feature allows for nonspecialized personnel to run and support the system, unless a severe hardware malfunction occurs.

RECOMMENDATIONS

The following recommendations, if implemented, are presented in the following order of priority.

1. A field test and evaluation of the system should be conducted to obtain data in the following question areas:

- a. Does the system provide an improved message product to the pilot?
- b. Are the message products, presented to the caller, representative of the most current information available?
- c. What is the utilization of the two new options available to the pilot in the system; i.e., specialist and fast-file?
- d. Is the pilot provided timely service in all areas of system utilization?

e. Is the specialist's workload reduced significantly by the advent of the system?

f. Is the caller's line-hold time reduced appreciably for a total transaction with the system; i.e., obtain the pertinent information for making a go/no go decision for a flight and if a decision is made to fly, filing a flight plan?

g. Does the system provide enough information and assistance for the pilot to decide on making a flight?

h. What is the general aviation public's feelings on the system overall?

2. The latest revision of the multitasking operating system should be incorporated into the system. A substantial amount of time savings in the input/output (I/O) overhead has been achieved in this current level of the operating system. The figures for the reduction in I/O overhead announced in the new operating system indicate that 20 audio output channels, an increase of 33 percent over the current capacity, could then be supported by the system.

3. An investigation into concatenation of weather messages at the word level should be conducted. This would involve the development of the software tools necessary to produce a vocabulary disc and retrieval of words from this disc to be strung together to form intelligible sentences. The vocabulary disc would contain the compendium of words necessary to produce any weather message product.

The main advantage to concatenation at the word level is a vast savings in storage over the technique involved in phrase level concatenation, where words have to be stored multiple times in different phrases. Another advantage gained by concatenation at the word level is less restraints are placed on the message originator in formatting a weather message product. A message can be generated in free text with the only constraint being that the word be a viable entry on the vocabulary disc.

The major benefit of this technique is a substantial savings in manpower. This is demonstrated by the fact that a message can be generated textually at a central location; transmitted in an ASCII mode to a remote site where it is concatenated and disseminated automatically, as in a Transcribed Weather Broadcast (TWEB) transmission outlet.

ND
DATE
L MED