

MICROCOPY RESOLUTION TEST CHART  
NATIONAL BUREAU OF STANDARDS-1963-A

12

DOT/FAA/RD-79/4, IV

Systems Research &  
Development Service  
Washington, D.C. 20590

# Longitudinal Joint Systems in Slip-Formed Rigid Pavements Volume IV - Recommendations for Alternate Joint Systems and for Strengthening Existing Joints

Linda Korbus

Ernest J. Barenberg

November 1981

Interim Report

This document is available to the U. S. public  
through the National Technical Information  
Service, Springfield, Virginia 22161

SELECTED  
APR 2 1982  
S A D



U.S. Department of Transportation  
Federal Aviation Administration

AD A112970

DTIC FILE COPY

## NOTICE

This document is disseminated under the sponsorship of the Department of Transportation in the interest of information exchange. The United States Government assumes no liability for the contents or use thereof.

1. Report No. DOT/FAA/RD-79/4, IV		2. Government Accession No. <b>AD-A112 970</b>		3. Recipient's Catalog No.	
4. Title and Subtitle Longitudinal Joint Systems in Slip-Formed Rigid Pavements; Vol. IV - Recommendations for Alternate Joint Systems and for Strengthening Existing Joints				5. Report Date November 1981	
7. Author(s) Linda Korbus Ernest J. Barenberg				6. Performing Organization Code	
9. Performing Organization Name and Address Department of Civil Engineering University of Illinois Urbana, IL 61801				8. Performing Organization Report No.	
12. Sponsoring Agency Name and Address U.S. Department of Transportation Federal Aviation Administration Federal Highway Administration Washington, DC 20590				10. Work Unit No. (TRAIS)	
				11. Contract or Grant No. DOT-FH-11-8474 MOD #4	
				13. Type of Report and Period Covered  Interim	
15. Supplementary Notes				14. Sponsoring Agency Code ARD-530	
16. Abstract <p>Load transfer across joints is a key factor in the performance of PCC pavements. The common load transfer devices in longitudinal joints for airport pavements have for many years been concrete keyways. Many of these keyways fail under heavy aircraft loads and are very difficult to construct using slip-formed pavers. Alternate joint systems which are potentially more reliable than keyways and which can be constructed using slip-formed pavers are presented in the report. Also, procedures are described for retrofitting existing slabs with devices to provide load transfer across joints or cracks. Laboratory and field tests with these load transfer devices are described, and data on their performance are presented. Recommendations for joint designs for PCC airport pavements are given based on the level of traffic anticipated.</p>					
17. Key Words PCC Pavements, Pavement Design, Airport Pavements, Load Transfer for PCC Pavements, Joints in PCC Pavements, Slip-Formed Pavements			18. Distribution Statement Document available to the Public through the National Technical Information Service, Springfield, VA 22151.		
19. Security Classif. (of this report) Unclassified		20. Security Classif. (of this page) Unclassified		21. No. of Pages 65	22. Price

\*

# METRIC CONVERSION FACTORS

Symbol	When You Know	Multiply by	To Find	Symbol
<b>LENGTH</b>				
mm	millimeters	0.04	inches	in
cm	centimeters	0.4	inches	in
m	meters	3.3	feet	ft
km	kilometers	1.1	yards	yd
		0.6	miles	mi
<b>AREA</b>				
cm <sup>2</sup>	square centimeters	0.16	square inches	in <sup>2</sup>
m <sup>2</sup>	square meters	1.2	square yards	yd <sup>2</sup>
km <sup>2</sup>	square kilometers	0.4	square miles	mi <sup>2</sup>
ha	hectares (10,000 m <sup>2</sup> )	2.5	acres	ac
<b>MASS (weight)</b>				
g	grams	0.075	ounces	oz
kg	kilograms	2.2	pounds	lb
t	tonnes (1000 kg)	1.1	short tons	st
<b>VOLUME</b>				
ml	milliliters	0.03	fluid ounces	fl oz
l	liters	2.1	pints	pt
l	liters	1.06	quarts	qt
m <sup>3</sup>	cubic meters	0.26	gallons	gal
m <sup>3</sup>	cubic meters	35	cubic feet	ft <sup>3</sup>
m <sup>3</sup>	cubic meters	1.3	cubic yards	yd <sup>3</sup>

Symbol	When You Know	Multiply by	To Find	Symbol
<b>LENGTH</b>				
in	inches	2.5	centimeters	cm
ft	feet	30	centimeters	cm
yd	yards	0.9	meters	m
mi	miles	1.6	kilometers	km
<b>AREA</b>				
in <sup>2</sup>	square inches	6.5	square centimeters	cm <sup>2</sup>
ft <sup>2</sup>	square feet	0.09	square meters	m <sup>2</sup>
yd <sup>2</sup>	square yards	0.8	square meters	m <sup>2</sup>
mi <sup>2</sup>	square miles	2.6	square kilometers	km <sup>2</sup>
	acres	0.4	hectares	ha
<b>MASS (weight)</b>				
oz	ounces	28	grams	g
lb	pounds (short tons (2000 lb))	0.46	kilograms	kg
		0.9	tonnes	t
<b>VOLUME</b>				
teaspoon	teaspoons	5	milliliters	ml
tablespoon	tablespoons	15	milliliters	ml
fluid ounce	fluid ounces	30	milliliters	ml
cup	cups	0.24	liters	l
pt	pints	0.47	liters	l
qt	quarts	0.95	liters	l
gal	gallons	3.8	liters	l
ft <sup>3</sup>	cubic feet	0.03	cubic meters	m <sup>3</sup>
yd <sup>3</sup>	cubic yards	0.76	cubic meters	m <sup>3</sup>
<b>TEMPERATURE (exact)</b>				
F	Fahrenheit temperature	5/9 (then subtract 32)	Celsius temperature	°C



Copyright © 1984 by The McGraw-Hill Companies, Inc. All rights reserved. Printed in the United States of America. ISBN 0-07-061111-1.

## Executive Summary

Use of keyways in longitudinal joints in Portland Cement Concrete (PCC) pavements for airports causes two potential problems. When constructing PCC pavements using slip form pavers, keyways are very difficult to construct. In many instances contractors have been unable to construct these keyways in a manner to meet existing specifications (1). Furthermore, such keyways tend to fail under the gear load of the heavy aircraft, resulting in lack of load transfer capacity and surface debris with concomitant maintenance problems for both the pavement engineer and the aircraft operator. Both of these problems were documented in field studies of actual pavements under construction and in service (2).

Under the current FAA procedure for pavement design (4) PCC slabs are assumed to be infinitely large for analysis purposes. These systems are then analyzed for stresses under interior or edge load conditions. Prior to design, assumptions are made with respect to the level of load transfer across the joints. Slab thicknesses are then computed to satisfy flexural stress requirements using the assumed load transfer level.

Computer programs were developed as a part of this study which permit the engineer to analyze the pavement system with a joint system as it will be in the finished pavement. These programs can analyze slabs with any level of load transfer across the joints, and can analyze one or two layer systems either bonded together or unbonded (2, 3). With the outputs from these programs the engineer can now select the most cost effective combination of joint patterns, load transfer, slab thicknesses and subbase thickness for the specific design aircraft selected for the airport pavement.

Based on a combination of results from analyses using the computer programs developed in this study, and the observed distress patterns of pavements in service, it was concluded dual criteria must be used for the effective design of airport pavements. It was shown that for airport pavements intended to handle aircraft with high wheel loads but with a moderate gross weight (aircraft with gear loads under 30,000 pounds), the stresses in the PCC slab were the critical parameter in pavement performance. For pavements intended to serve the heavier aircraft (such as the L-1011, DC-10 and 747), the maximum stress on the subgrade was at least as critical as the stress in the slab in reducing pavement performance.

With those aircraft for which the maximum stress in the slab is the critical parameter, increasing the slab thickness is an economical method of improving pavement performance. With pavements designed to serve aircraft with heavy gear loads (L-1011, DC-10, 747), for which maximum subgrade stress is as critical as slab stress in the performance of the pavement, there is a need for a high level of load transfer across both the longitudinal and transverse joints.

A number of alternate joint systems designed to provide load transfer were examined for use in the longitudinal joints for airport pavements. Critical factors in these systems were the constructability of the joints using slip form pavers, and the performance of the joint with respect to its load transfer capability. A number of joint systems which appeared technically feasible under these criteria were presented in Reference 1. Little field data are available on the actual cost and performance of most of the proposed systems. Further development of some of these systems may be cost effective.

Based on the performance of systems which have been tried it was determined that for pavements intended to serve primarily aircraft with relatively light gear loads, untied butt joints were effective if constructed on a stabilized subbase. For pavements intended to serve aircraft with heavier gear loads, some type of load transfer is required even if a stabilized subbase is used. For this purpose large diameter tie bars (1 to 1-3/8 inch diameter) or large diameter dowels (1-1/4 to 2 inch diameter) were determined to be cost effective. Furthermore, it was found that the tie bars and dowels could be economically installed in the plastic concrete when using slip form pavers. This was accomplished using a pneumatic "gun" to shoot the tie bars and dowels into the plastic concrete. A slot was provided near the trailing edge of the slip form to accommodate the bars or dowels.

A load transfer device was developed which can be installed in a vertical core hole cut across the pavement joint in the hardened concrete. This device can be retrofitted to existing pavements which develop distress due to improper load transfer, or can be used to reinforce the load transfer across the longitudinal and transverse joints at their intersection where effective load transfer is most critical.

Finally, joint systems are recommended for airport pavements designed for different types of aircraft. Joint load transfer systems are given for aircraft pavements intended to carry light, medium and heavy weight aircraft.

v



DTIC	1
COPY	1
INSPECTED	1
3	1
Distribution/	
Availability Codes	
Avail and/or	
Special	

## TABLE OF CONTENTS

CHAPTER		Page
I	INTRODUCTION -----	1
	Objective -----	1
	Scope -----	1
2	NEED FOR LOAD TRANSFER SYSTEMS -----	6
3	LOAD TRANSFER SYSTEMS -----	18
	Seattle-Tacoma International Airport -----	19
	Chicago O'Hare International Airport -----	19
	Greater Pittsburgh Airport -----	22
	Alternate Load Transfer Systems -----	24
	Test Specimens -----	30
	Compression Test -----	32
	Tension Test -----	32
	Shear Test -----	32
	Moment Test -----	35
	Fatigue Test -----	35
4	PRESENTATION AND DISCUSSION OF LABORATORY TEST RESULTS -----	39
5	FIELD TESTS ON LOAD TRANSFER DEVICES -----	50
6	COST -----	54
7	RECOMMENDATIONS AND CONCLUSIONS -----	58
	Recommendations -----	58
	Conclusions -----	58
	REFERENCES -----	65

## LIST OF TABLES

Table		Page
1	Relative Thickness Requirements for Pavements with and without Load Transfer -----	7
2	Effect of Load Transfer Efficiency on Maximum, Bending Stress, Deflection and Subgrade Stress -----	11
3	Stresses and Deflections in PCC Pavement as Affected by Load Transfer -----	13
4	Summary of Relative Deflections across Joints, Sea-Tac International -----	20
5	Results from Field Tests at San Diego (Lindberg) Airport by Brandley -----	52
6	Summary of Costs for Installation of Various Load Transfer Systems -----	55
7	Total Estimated Cost of Various Load Transfer Systems -----	56
8	Recommended Load Transfer Systems for Airport Pavements -----	59

## LIST OF FIGURES

Figure	Page
1 Effect of Load Transfer Efficiency on Maximum Flexural Stresses under Aircraft Loading -----	8
2 Maximum Edge Load Bending Stress for Various Slab and Subbase Thicknesses Expressed as a Ratio with Comparable Stress in 18 inch PCC Slab on an 18 inch Stabilized Subbase ----	10
3 Effect of Load Transfer Efficiency as Specified by the AIF on maximum Edge Deflection of PCC Slabs -----	15
4 Maximum Deflection for Various Slab and Subbase Thicknesses Expressed as a Ratio to Comparable Deflection in an 18 inch PCC Slab on an 18 inch Stabilized Subbase -----	17
5 Figure 8 Load Transfer Device -----	26
6 Initial and Fabricated Versions of Diamond Device Developed at University of Illinois -----	27
7 Intermediate Version of U of I Device -----	28
8 Plate and Stud Load Transfer Device -----	29
9 Concrete Block Test Specimens Used to Evaluate Load Transfer Devices in Laboratory -----	31
10 Schematic of Tension Test to Evaluate Resistance to Joint Opening -----	33
11 Shear Test to Measure Load Transfer Effectiveness -----	34
12 Test Setup for Moment Test with LTD -----	36
13 Fatigue Test Setup for Three inch Size Figure 8 and Diamond Devices -----	37
14 Load versus Joint Opening in Direct Tension for Various Load Transfer Devices -----	40
15 Load versus Closure of Load Transfer Devices Tested in Compression -----	41
16 Deflection versus Load for Jointed Blocks with Load Transfer Devices Tested in Bending -----	43
17 Joint Rotation with Figure Eight and Three inch Diamond Devices -----	44

Figure	Page
18	Results from Shear Tests on Blocks with Load Transfer Devices ----- 45
19	Fatigue Performance of Welded 3 inch Diamond Device ----- 47
20	Fatigue Results from Model Slabs with Figure Eight Device ----- 48
21	Test Beam and Schematic of Field Test Procedure for Measuring the Relative Deflection across Joints ----- 51
22	Recommended Load Transfer at Corners for Airport Pavements for Medium Aircraft ----- 60
23	Recommended Load Transfer for Longitudinal and Transverse Joints for Airport Pavements to Serve Medium to Heavy Aircraft ----- 61
24	Recommended Load Transfer for Longitudinal and Transverse Joints for Airport Pavements to Serve Heavy Aircraft ----- 62

CHAPTER 1  
INTRODUCTION

Construction of longitudinal joints in slip formed concrete pavements has caused special problems for both the contractor and the pavement maintenance engineer. For the contractor these problems are related to construction of the slip formed edge with load transfer devices. Maintenance problems are caused because the most popular method of load transfer in longitudinal joints, namely the keyway systems, frequently fail under today's heavy aircraft loading.

Reports from the field indicate a significant incidence of failure in keyed joint systems. There is some evidence that tying the keyed joints will reduce these failures, but tying keyed joints with slip form pavers has caused serious construction problems. Thus alternate solutions are needed to provide adequate load transfer in longitudinal joints constructed with slip formed pavers.

Objective

The objective of this study under Contract DUT-FH-8474, Mod 4 was to determine the cost effectiveness of load transfer systems across longitudinal joints of slip-formed pavements for civil airports. The end product desired is a rating in terms of the cost effectiveness and performance of the most promising of the load transfer systems.

Scope

This effort will consist of: (1) an evaluation of load transfer devices installed in slip-formed construction projects, (2) investigation of concepts for new load transfer systems, and (3) development of criteria and analysis of load transfer systems. The analysis is expected to provide results in terms of joint design criteria and the cost effectiveness of

each load transfer system. It is anticipated that the most cost effective load transfer systems developed from this program will be evaluated in future airport construction. Field installation and evaluation are not a part of this study.

Earlier reports (1, 2) have documented the problems associated with longitudinal joints in concrete pavements. Essentially two major problems were described which were associated with keyways normally used in the longitudinal joints. These are problems associated with the construction of keyways when paving with slip form pavers, and failure of the keyways due to heavy gear loads.

In Reference 1 it was concluded that the construction of keyways with slip form pavers is a major source of difficulty in PCC pavements for airports. It was noted in the report that there were instances where keyways had been successfully installed in pavements using slip form pavers, but that the degree of skill required by the contractor to achieve a satisfactory keyway is very high. By some modification in the construction procedure it is believed that the construction problems could be overcome.

The poor performance of the keyways under heavy aircraft gear loads is a more serious problem. As documented in Reference 1, many keyways fail under the repeated application of heavy gear loads. This normally results in loose concrete on the pavement surface which, under some conditions, can be ingested in the aircraft engines causing severe damage to the turbine blades. This problem is much more severe in thinner pavements than with the thicker pavements. The problem, when it occurs, is so severe that some airport engineers make a practice of sawing off the male portion of the keyway at the first sign of keyway distress.

Also in Reference 2, several alternate joint and load transfer systems for use in longitudinal joints in airport pavements are evaluated. The report documents finite element programs developed to analyze the various pavement systems with keyways and/or alternate load transfer systems. While the analysis procedures were incidental to the objects of this study, development of these programs may be the most valuable finding from this study.

A major segment of the analysis program is a computerized model called ILLI-SLAB. This program, which is documented in References 2 and 3, can be used to analyze PCC pavements with cracks and joints, with varying and specifiable levels of load transfer across the cracks and joints. The program is also capable of analyzing pavements with either one or two layers which can be either bonded together or unbonded, and can have layers of varying thickness and varying moduli of elasticity. The program can handle both the dense liquid and elastic solid subgrade supports.

A user manual for the ILLI-SLAB computer program was prepared. A reference to this user manual can be found in Reference 3.

Detailed analyses of the various load transfer systems using these finite element programs showed several interesting findings. Among the findings is the fact that the stresses in keyways under heavy gear loads are sufficiently high as to cause keyway failure under a limited number of load applications. Furthermore, it was shown that changing keyway dimensions did not improve the stress conditions, and many modifications to keyway dimensions actually caused the increase in the stresses developed. Thus, it was concluded that keyways were not a viable option for load

transfer for longitudinal joints even if the construction problems with the slip form paver were resolved.

Further analysis of the various proposed joint systems shown in Reference 2 indicated that dowels or large tie bars were the most promising options for the longitudinal joints. Analysis of the doweled or tied joints showed that the primary performance problems associated with the dowels, namely elongation of dowel sockets, can be resolved by using large diameter dowels. There are some construction problems associated with the installation of dowels in longitudinal joints when slip form pavers are used, and these problems are addressed in this report.

In addition to the studies referred to above, and the resulting reports, several pavements at Chicago's O'Hare International Airport were instrumented and tested. Loading of the instrumented pavements was accomplished with several nondestructive testing devices including the Corps of Engineers 16 kip vibrator, the Illinois DOT and Corps of Engineers Model 2008 Road Raters, a Dynaflect device, and a Falling Weight Deflectometer. In addition, the pavements were loaded with aircraft of various gear types, under normal operating conditions. While some of the funds for instrumentation of the Chicago study was provided by FAA under this contract, the major portion of the funds were supplied by others. The final report on the findings from the instrumentation at O'Hare is in progress.

This report summarizes the findings from the previous studies and brings them into focus in the form of recommended designs for longitudinal joint systems for PCC pavements for airports. The report examines the need for load transfer for both the longitudinal and transverse joints, and

recommends some minimum load transfer systems based on type and magnitude of the aircraft gear load. Some problems associated with installation of dowels and/or tie bars in longitudinal joints when paving with slip form pavers are discussed and solutions presented.

Finally some relative cost data of various joint systems with and without load transfer are presented. The most cost effective systems are recommended for consideration for airport pavements.

## CHAPTER 2

### NEED FOR LOAD TRANSFER SYSTEMS

Before considering the type and cost effectiveness of load transfer systems for PCC pavements, it is necessary to consider the need for these systems. The Navy has for a number of years used PCC pavements with butt joints over a stabilized subbase with good results for light loads. Also, some commercial airports have PCC pavements with no load transfer across the longitudinal joints, because the male portion of the keyway was sawed off to prevent shearing of the keyway under load. Some of these systems are on stabilized subbases and some are not. In general these pavements have given good performance. Thus, there is a question as to whether load transfer is needed across the longitudinal joints, and if so, under what conditions and how much?

Since less load transfer across a longitudinal joint will result in higher stresses in a slab under a given load, it follows that the elimination of the load transfer could be compensated for by an increase in slab thickness. Load transfer capability of a joint is measured by the joint efficiency. Joint load transfer efficiency is defined as a ratio of the deflection of the unloaded slab to that of the loaded slab expressed as a percent. This is given by the equation:

$$\text{LTE} = \frac{\delta_u}{\delta_L} \times 100 \quad (1)$$

where LTE is the load transfer efficiency expressed as a percent

$\delta_L$  is the deflection of the loaded slab

$\delta_u$  is the deflection across the joint of the unloaded slab

In the same manner the efficiency of a joint in reducing stress in the PCC slab can be expressed as

$$\text{Stress Eff} = \frac{\sigma_u}{\sigma_L} \times 100$$

where  $\sigma_u$  is the stress in the unloaded slab

$\sigma_L$  is the stress in the loaded slab

With these definitions, the effective stress reduction can be expressed as a function of the load transfer efficiency. Figure 1 shows the stress reduction in a slab as a function of the load transfer efficiency expressed both in terms of deflection and stress.

For single wheel loads of 50,000 lb (22.7 Mg) or less, the approximate load transfer efficiency needed with different slab thicknesses to maintain the same maximum bending stress is given in Table 1.

Table 1. Relative Thickness Requirements for Pavements with and without Load Transfer

Slab Thickness Required without Load Transfer	Load Transfer Efficiency Needed with a 12 inch Slab
18	100
16	85
14	58
12	0

Current FAA design assumes that there will be a 25 percent reduction in stress from a free edge condition (4). From Figure 1 it is seen that this 25 percent reduction translates to an effective load transfer

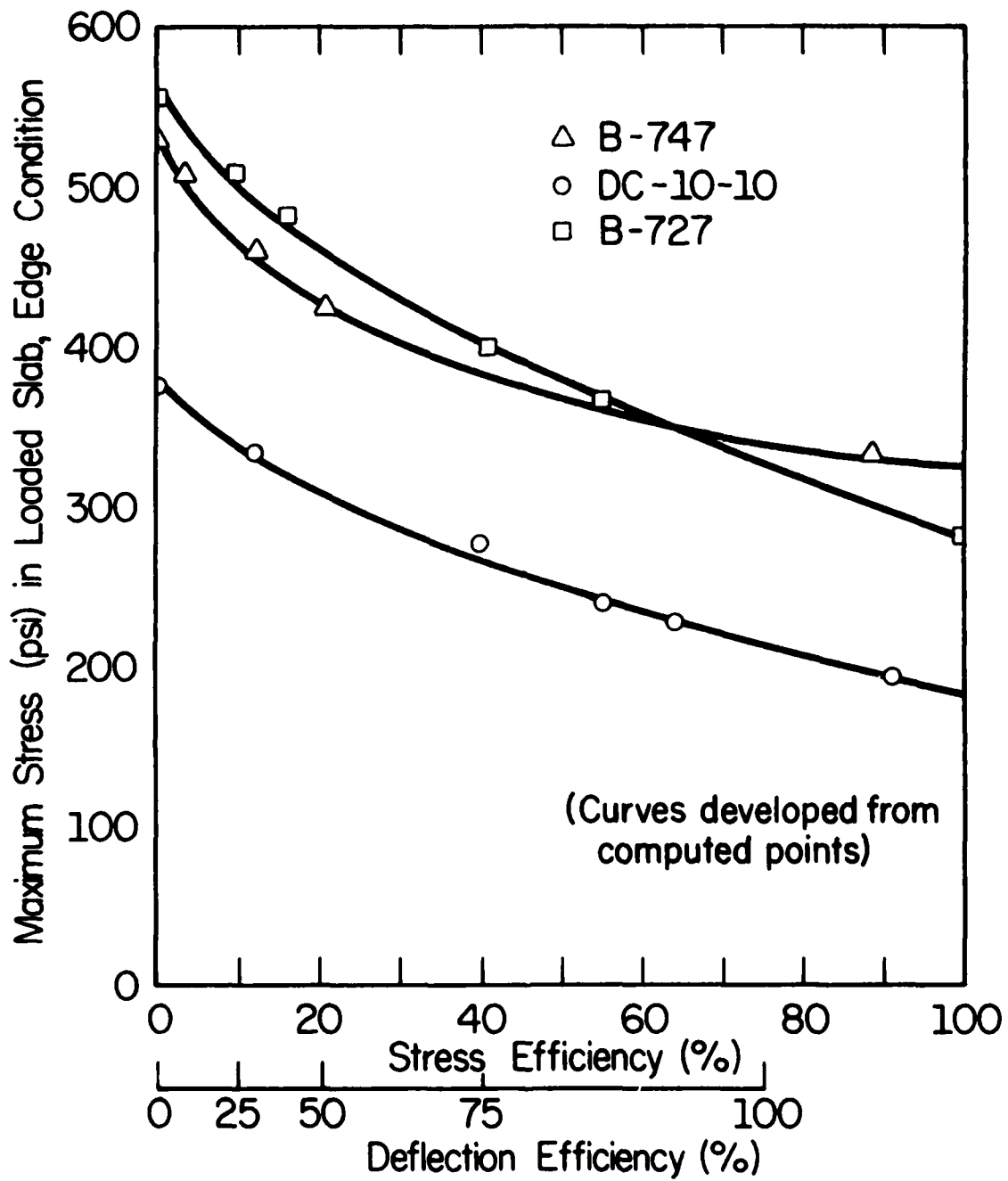

Figure 1. Effect of Load Transfer Efficiency on Maximum Flexural Stresses under Aircraft Loading.

efficiency based on deflection of between 60 to 70 percent. From the values given in Table 1 it can be seen that a 14 inch slab with no load transfer is equivalent to a 12 inch slab with 58 percent load transfer. For these conditions it appears that approximately 2 to 3 inches of added thickness is needed to compensate for the increased stress for a loss in load transfer efficiency from approximately 60 percent to zero. This value will vary somewhat with slab thickness and gear configuration, but an increase in slab thickness of between 15 and 25 percent appears to compensate for the increased stress due to loss of load transfer for most cases.

It has also been suggested that an increase in thickness of stabilized base can be used to compensate for the increase in stress due to reduced load transfer efficiency (4, 5). Figure 2 shows the relative effect of subbase thickness and slab thickness on maximum bending stress in the slab. These curves are based on analyses with ILLI-SLAB program (2, 3, 6) and assume no bond between slab and subbase, and that the subbase layer will crack and have the same relative load transfer efficiency as the slab. This latter assumption is based on the high percentage of reflective cracks which propagate from joints in the PCC slab through the stabilized subbase. From the trends shown in the curves in Figure 2 it is apparent that added slab thickness is more effective in reducing maximum stresses in the slab than increasing the subbase thickness.

If stresses in the slab were the only cause for distress in PCC pavements, then the butt joints without load transfer would appear to be cost effective. There is, however, strong evidence that permanent deflection of the subgrade soil may also be a cause of distress in PCC slabs. This problem is especially critical for pavements which carry a high number of aircraft with heavy gear loads such as the DC-10, L-1011, or B-747.

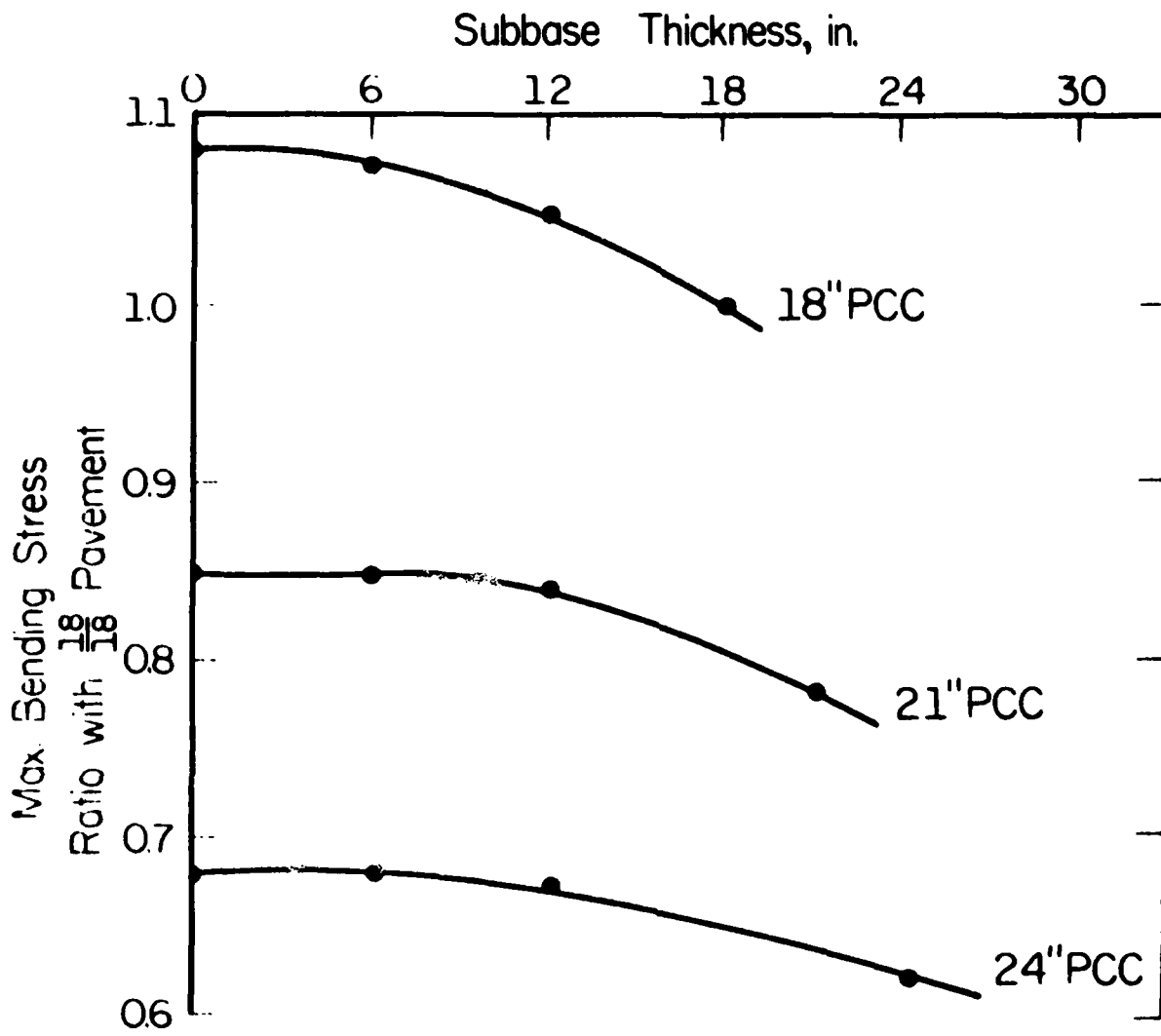

Figure 2. Maximum Edge Load Bending Stress for Various Slab and Subbase Thicknesses Expressed as a Ratio with Comparable Stress in 18 inch PCC Slab on an 18 inch Stabilized Subbase.

Removal of several failed slabs in the outer circular taxiway at Chicago's O'Hare International Airport revealed a permanent deformation of the subgrade at the corners of several failed slabs (6). It was apparent in these failures that much of the problem was caused by high slab deflection and the concomitant high stress on the subgrade. Listed in Table 2 are the maximum edge stress, maximum corner deflection, and corresponding subgrade stress for a 12 inch thick PCC slab under a 30,000 lb (13.6 Mg) single wheel gear load. Slab support for this analysis was an unstabilized subbase with an assumed "k" of 200 pci on the top of the subbase.

Table 2. Effect of Load Transfer Efficiency on Maximum Bending Stress, Deflection and Subgrade Stress

<u>Load Transfer Efficiency (%)</u>		Maximum Edge Stress (psi)	Maximum Corner Deflection (inches)	Maximum Subgrade Stress (psi)
<u>Longitudinal Joint</u>	<u>Transverse Joint</u>			
0	0	395	.075	15
0	90	395	.039	7
90	90	230	.021	4

For these analyses the single gear load was placed next to the longitudinal joint, with the load at mid-slab for the maximum edge stress, and at the transverse joint for the maximum corner deflection and maximum subgrade stress calculations.

The results in Table 2 indicate the 12 inch slab without load transfer at either joint would be satisfactory based on a limiting stress in the concrete but the design is marginal based on the maximum corner deflection and the concomitant maximum subgrade stress. While no limiting subgrade

stress criteria has been established for airport pavements, results from highway pavements suggest that a stress of 15 psi on a subgrade with a "k" of 200 pci is excessive (7,8).

As seen in Table 2, this situation is greatly relieved when only one joint, say the transverse joint, has a partial load transfer. A better design, however, may be to use a stabilized subbase to partially relieve the deflection and subgrade stress problem along with partial load transfer at one joint. In any event, it appears that an effective PCC pavement system can be designed for aircraft with maximum gear loads of less than 30,000 lb (13.5 Mg) without the use of load transfer in the longitudinal joint. These analyses would substantially confirm the Navy's experience with this type of joint.

The situation with pavements to serve aircraft with significantly greater gear loads is quite different from the one just described above. With the heavier gear loads it is uneconomical to develop a design without good load transfer in at least one joint, and for the wide body aircraft, effective load transfer may be needed in both longitudinal and transverse joints. Table 3 shows the calculated maximum stresses and deflections in a PCC slab with low and high load transfer efficiencies for three common aircraft types. The results indicate little problem in achieving a satisfactory bending stress in the slab for all three aircraft, but that the maximum deflection and maximum vertical stress on the subgrade under the wide body aircraft are far too high to provide good performance when the load transfer efficiency of the joints are low. Providing a high level of load transfer at only one joint materially helps the situation, but to achieve what is believed to be

Table 3. Stresses and Deflections in PCC Pavement as Affected by Load Transfer

Aircraft (Gross WGT)	Max. Slab Stress <sup>a</sup> , psi (Edge Load)	Joint Efficiency	Max. Deflection and Subgrade Stress <sup>a</sup> (Corner Load)							
			<10%	<90%	10/10		10/90		90/90	
			Defl (in.)	$\sigma_z^b$ (psi)	Defl (in.)	$\sigma_z^b$ (psi)	Defl (in.)	$\sigma_z^b$ (psi)	Defl (in.)	$\sigma_z^b$ (psi)
727-200 (173K)	340	209	.09	9	.05	5	.03	3		
DC-10-30 (558K)	425	270	.19	19	.11	11	.06	6		
747 (778K)	360	220	.18	18	.10	10	.06	6		

<sup>a</sup> Pavement System = 21 inch PCC on 6" Stabilized Subgrade  
k subgrade = 100 pci

<sup>b</sup>  $\sigma_z = k \times \text{deflection}$

Note: 100 K = 45.4 Mg  
1 psi = 6.9 k pa  
1 in. = 25.4 mm

a satisfactory level of deflection and stress on the subgrade with these aircraft requires a relatively high level of load transfer at both joints. In each instance the aircraft gear was positioned to produce the greatest pavement response for the loading condition indicated. The findings discussed above indicate that dual criteria of slab stress and slab deflection should be used for reliable pavement design, especially for pavements to serve heavy aircraft. Also, the results indicate the effect of load transfer is greater when considering the maximum slab deflection than when considering the maximum stress in the slab.

Figure 3 shows the maximum deflection at the edge of a slab as affected by the load transfer effectiveness. In these results it is important to note that the sum of the deflections of the loaded and unloaded slabs remains nearly constant at a value almost identical to the maximum deflection of the loaded slab without any load transfer. This means that the maximum slab deflection under edge loading and the concomitant maximum stress on the subgrade can be reduced to approximately one-half the maximum free edge deflection by means of effective load transfer.

The maximum slab deflection under corner load is even more sensitive to load transfer efficiency than under edge loading. As shown in Table 3, under corner loading, the maximum free corner deflection can be reduced again by approximately one-half by good (90%) load transfer in both perpendicular joints. Thus, it is possible to reduce the corner deflection to one-fourth or one-third the free corner deflection by means of effective load transfer across both joints.

As was indicated for the maximum slab stress, use of a stabilized subbase is not an effective way of reducing the maximum slab deflection.

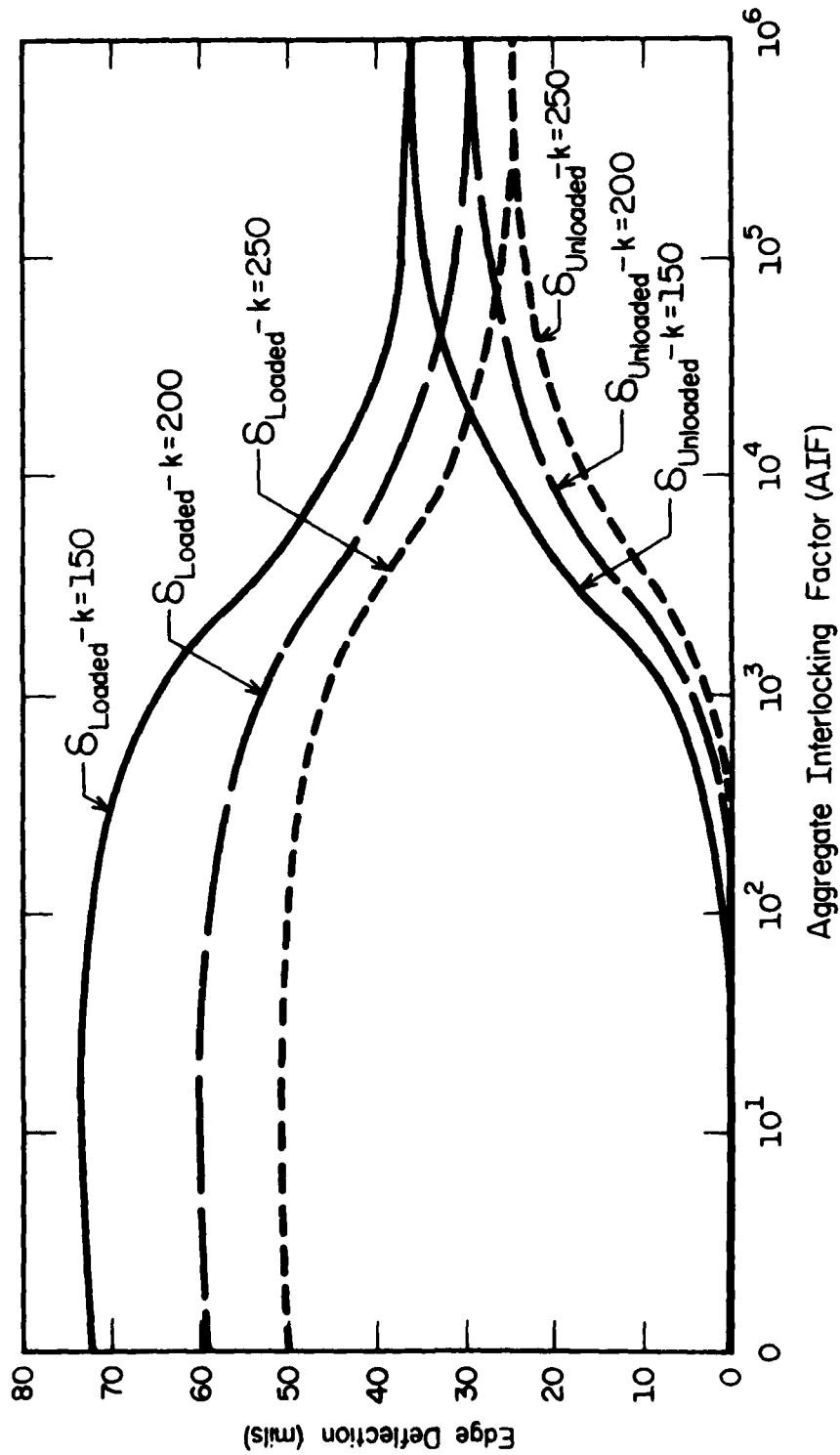

Figure 3. Effect of Load Transfer Efficiency as Specified by the AIF on Maximum Edge Deflection of PCC Slabs.

Figure 4 shows how slab deflection is affected by the thicknesses of slab and subbase layers (6). Obviously, increasing slab thickness is much more effective in reducing pavement deflection than increasing subbase thickness, but increasing the thickness of either the slab or the subbase is less effective than increasing load transfer efficiency. Results in Table 3 shows the effect of increasing the load transfer on one or both joints on the slab corner deflection under the B-747 and DC-10 aircraft (6).

Based on the above analyses and examples it is apparent there is no single answer to the question as to the need for load transfer for joints for airport pavements. What can be concluded is that for pavements intended to serve only light aircraft the need for load transfer is less critical. Conversely, for pavements intended to serve aircraft with heavy gear loads there is a definite need for load transfer across both longitudinal and transverse joints. For pavements to serve medium weight aircraft (DC-9, B-737, etc.) effective load transfer across one type joint, either the longitudinal or the transverse joint, would likely be adequate. Based on the tests by Brandley<sup>\*</sup> at Seattle-Tacoma International Airport (7), and as noted in Reference 1, it is generally better to have effective load transfer in the joints transverse to the direction of aircraft travel rather than parallel to it. These results are also shown in Table 4 in Chapter 3 of this report.

\* Reinard W. Brandley, Consulting Engineer, Sacramento, CA 95825

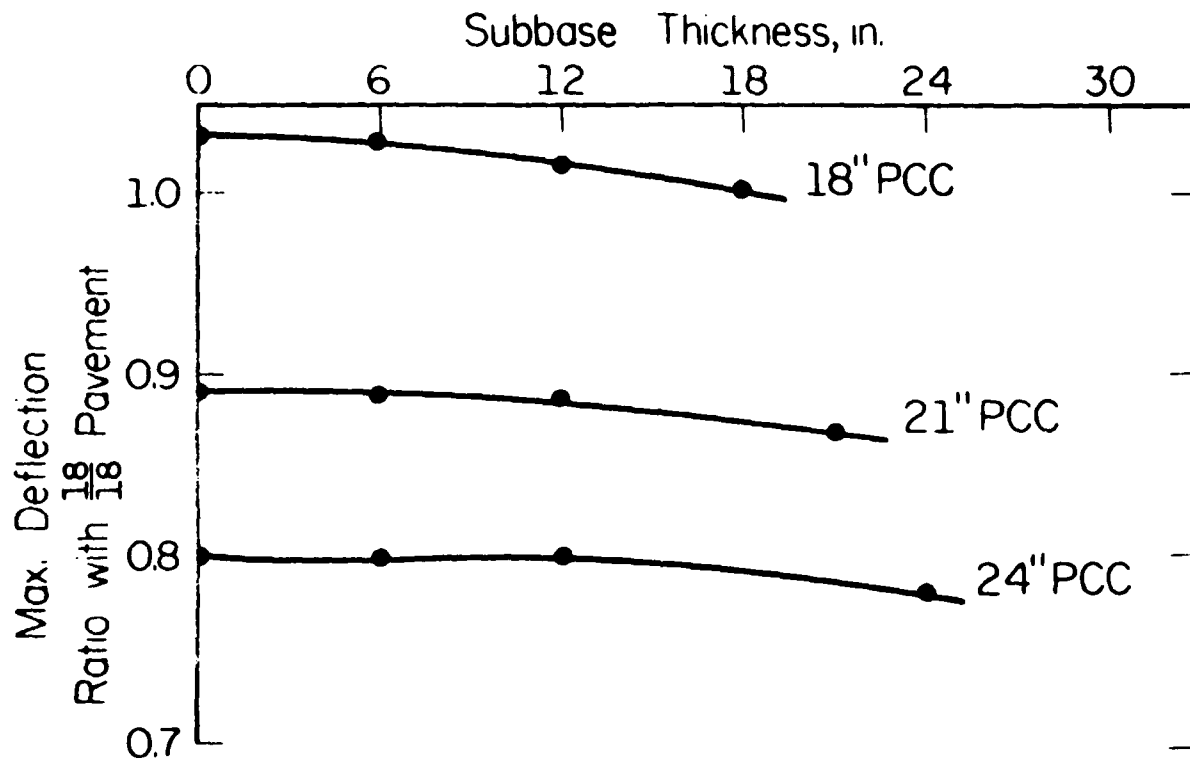

Figure 4. Maximum Deflection for Various Slab and Subbase Thicknesses Expressed as a Ratio to Comparable Deflection in an 18 inch PCC Slab on an 18 inch Stabilized Subbase.

CHAPTER 3  
LOAD TRANSFER SYSTEMS

In Report No. FAA-RD-79-4, I (Ref. 1) a number of possible alternate load transfer systems were described. Subsequently in Report No. FAA-RD-79-4(II) (Ref. 2) several of these systems were analyzed for load transfer effectiveness. The basic findings from these analyses include the following:

- Dowels may make a very effective load transfer system but there is danger of dowel socket enlargement under repeated load applications, thus reducing their load transfer effectiveness. Dowel socket enlargement can be substantially reduced to an acceptable level by keeping the dowel-concrete interaction stress to an acceptable level. The most effective method of reducing the dowel-concrete interaction stress is by increasing the dowel size. As shown in Reference 2, this interaction stress decreases with the  $4/3$  power of the dowel diameter, all other factors being equal.
- Aggregate interlock is also an effective load transfer mechanism. The long term effectiveness of aggregate interlock as a load transfer mechanism is significantly reduced if the joint is allowed to open to any significant degree. In Reference 2, data from tests on aggregate interlock by PCA shows that joint openings of as little as 0.03 inch (0.76 mm) significantly reduce the effectiveness of aggregate interlock for load transfer. The loss in effectiveness becomes increasingly worse under the action of repeated load applications. It was also shown that when the joint is held tightly closed, aggregate interlock provides excellent load transfer system and maintains its effectiveness even under a high number of load applications.

To further validate these conclusions several airport pavements with combination load transfer systems in the longitudinal and transverse joints were examined. Results of these evaluations are summarized below by facility.

#### Seattle-Tacoma International Airport

A number of tests were run on instrumented pavements at Sea-Tac International Airport by its consultant, R. Brandley (7). One of the specific instrumentation packages was designed to measure the relative vertical movement across the various type joints under moving aircraft. Results of these measurements are shown in Table 4. The longitudinal joints for this facility were thickened edge PCC slabs with the thickness at the longitudinal joints 18 inches (0.46 m) with keyways. The keyways had not failed in these joints at the time of these tests and, to the best of the authors' knowledge, are still performing well (7, 8).

A review of the data in Table 2 indicates all joints are performing well except the sawed joints with no ties or dowels. This confirms the earlier statement that aggregate interlock gives effective long term load transfer only if held tightly closed. For both the sawed longitudinal and transverse joints with no dowels or ties, the relative deflection was much greater than when these joints were tied and/or doweled. Also, it was noted that the loss in load transfer efficiency with the untied, undoweled joints is much greater for transverse joints than for the longitudinal joints. This is consistent with other observations on the relative performance of transverse versus longitudinal joints.

#### Chicago O'Hare International Airport

A wide range of load transfer systems has been used at Chicago's O'Hare International Airport (8, 9). These include tied and untied keyed

Table 4. Summary of Relative Deflections across Joints,  
Sea-Tac International (7)

Aircraft		Gross Weight (kips)	Relative Deflection across Joints by Type Joint (inches)				
Designation	Longitudinal Joints		Transverse Joints		Sawed and Doweled		
			Ties or Dowels	Sawed - No Ties or Dowels	Sawed - Tied	Ties or Dowels	Sawed and Doweled
747		700	.007	.014	.006	.034	.003
		600	.006	.012	.005	.029	.003
		500	.005	.010	.004	.024	.002
DC8		250	.004	.010	.004	.028	.002
	B707	200	.003	.008	.003	.022	.002
B727		150	.002	.007	.002	.017	.001
		150	.003	.008	.004	.024	.002
		125	.002	.007	.003	.020	.002
B737		100	.002	.005	.003	.016	.001
		100	.002	.005	.002	.016	.001
DC9		75	.001	.004	.002	.012	----

joints, tied and untied butt joints, and doweled joints. A review of the performance of these joint systems provides substantial insight into the most cost effective joint systems.

Keyed joints, both tied and untied, have not performed well at O'Hare. Runway 27L-9R was a 10 to 12 inch thick continuously reinforced pavement with tied-keyed longitudinal joints placed on a granular subbase. These keyways started to fail shortly after construction and the male portion of the keyway was sawed off to prevent further failures, as the failures were causing loose concrete to accumulate on the pavement surface. After sawing these joints they effectively became untied butt joints. These pavements have been in service for nearly 15 years, and have been overlaid once with 6 inches of AC. The sawed keyways in the longitudinal joints have performed well, with no unusual problems on one of the busiest runways at O'Hare.

Pavements in the outer circular taxiway at O'Hare International were designed as 15 inch jointed concrete slabs with 50 foot transverse joint spacing on granular subbase. Longitudinal joints were keyed and transverse joints doweled using 1-1/4 inch dowels at 12 inch centers. In 1978, several slabs which had cracked and faulted were removed and replaced (9). Upon removal of the slabs, shear failure was apparent along much of the male portion of the keyway, and the dowels in the transverse joints were bent and loose in their sockets. These pavements were over 15 years old at the time of removal, and had carried extremely heavy traffic (probably over 50,000 equivalent departures annually with many wide body aircraft) at the time of the investigation (8, 9).

Runway 4R-22L at O'Hare International was constructed in 1971 and 1972 as a continuously reinforced pavement 14 and 16 inches thick with a

stabilized subbase. The three longitudinal joints in the center of the runway were constructed as butt joints with 1-1/4 deformed tie bars at 12 to 15 inch centers. This pavement is performing well to date with no distress at the longitudinal joints (8, 9).

Recently (1979) several connector taxiways at O'Hare International were designed and constructed with large diameter (2 inch) dowels in the transverse joints and large diameter tie bars (1-3/8 inch) in the longitudinal butt joints. Since these connectors were between the inner and outer circular taxiways and near the International Terminal, they are expected to carry a significant number of fully loaded wide body aircraft. To date these pavements have performed well.

#### Greater Pittsburgh Airport

As indicated earlier in this report, a major problem with the use of dowels and tie bars in longitudinal joints is with the installation when using slip-form pavers. Recently a contractor doing the paving for the extensions of the runways and taxiways at the Greater Pittsburgh Airport successfully modified a CMI slip form paver so that large diameter dowel and tie bars could be installed in a semi-automatic manner during the paving operation (10).

Basically, the installation of the 1-1/4 inch diameter dowel and tie bars was accomplished by "shooting" the bars into the plastic concrete using compressed air. A slot was cut into the moving form of the slip form paver starting approximately 30 inches from the rear edge of the form (just ahead of the rear tread on the paver). A guide was attached to hold the bar in its proper alignment. A compressed air cylinder was attached to force the bar along the guide and into the plastic concrete. During

paving of the Greater Pittsburgh Airport, the pneumatic "gun" was tripped manually by a laborer at predetermined intervals. Automatic tripping and feeding devices could easily be developed for this installation, thereby reducing labor costs for the installation. For this approach to work without disturbing the plastic concrete, the maximum particle size in the concrete aggregate should be no larger than the dowel or bar diameter, as larger particle sizes may deflect the bar during installation and create misalignment. This is not a serious problem when using tie bars, but would create problems when using dowels for which alignment is critical.

Other airports have also used dowels installed in butt joints with highly favorable results. Several of these have been reported to the authors and are mentioned here so that these installations can be monitored for future evaluation of this type of longitudinal joint.

Milwaukee, Wisconsin	(8)
Louisville, Kentucky	(11)
Salt Lake City, Utah	(11)
Houston International Airport	(8)

For the airports listed above, the dowels were installed by forming butt joints instead of keyways, and later by drilling sockets for installation of the dowels. Dowels were grouted into place using either a sand cement or an epoxy grout. The epoxy grout was used in most cases. Details on the specific grout are not available.

All of the pavements listed above have been in service from 3 to 8 years and are performing well.

### Alternate Load Transfer Systems

A major problem when using either tie bars or dowels in the longitudinal joint, and dowels in the transverse joint, is the potential interference near the intersection of these joints. In relatively thick pavements (14 inches or greater) it may be possible to place the bars or dowels for the intersecting joints in different horizontal planes near the centerline. This may cause some construction problems, however, as the dowels are normally fixed in baskets for the transverse joints, and the bars for the longitudinal joints, when inserted in the plastic concrete with slip form pavers, rest in a guide set at a fixed level. Another possibility would be to eliminate the last dowel in the transverse joint or the last tie bar or dowel in the longitudinal joints. This results in one less bar or dowel at just the point in the pavement where the maximum load transfer is needed, namely near the corners of the slabs.

Because of the problems associated with installation of dowels and tie bars at the intersection of the longitudinal and transverse joints, and the need for a high level of load transfer at the intersection of these joints, alternate load transfer systems were considered for installation at this location in the pavement. Such a load transfer system should be economical, easy to install, and should transfer the load at least as effectively and efficiently as the conventional dowels and tie bars discussed earlier. One possibility would be to omit one bar from the longitudinal joint when inserting in the plastic concrete and then install an extra bar near the joint by drilling and grouting into place, probably with an epoxy type grout.

Recent reports have described a new concept for reestablishing load transfer across an existing joint or crack (12, 13, 14). Basically, the method consisted of drilling a series of full depth cores vertically through the joint, dropping a load transfer device into the hole and filling the remaining void with an epoxy-concrete, polymer concrete or similar type grout. Joint connection was achieved in France by a device described in Reference 12, shaped like a figure eight to transfer shear across the joint. This device is shown in Figure 5. As illustrated in the figure, a cardboard or plastic divider is placed in the joint to separate the epoxy or polymer concrete and to leave the slabs free to move with changes in temperature.

The figure-eight device (French Connection) described above excessively constrained the opening & closing of the joint. Therefore, a device shown in Fig. 6 was developed as part of this study. The diamond shaped device was designed to transfer shear across the joint while maintaining flexibility to permit its opening and closing. The diamond shaped interior portion provides flexibility across the joint while the flanges provide for bond to transfer shear. A compressible shield is normally fitted over the faces near the tips of the diamond as shown in Figure 7 to eliminate stress concentrations at the tips of the diamond caused by contraction or expansion of the concrete slab. The shield would also prevent the epoxy from bonding to the diamond shaped bellows and would also act as a seal to prevent the epoxy from flowing into the joint during installation.

Related to this type of methodology is a third device shown in Figure 8 designed by Mr. Reinard Brandley from Sacramento, California for rehabilitation of the pavements for the Lindberg Airport (11). The dowel and plate

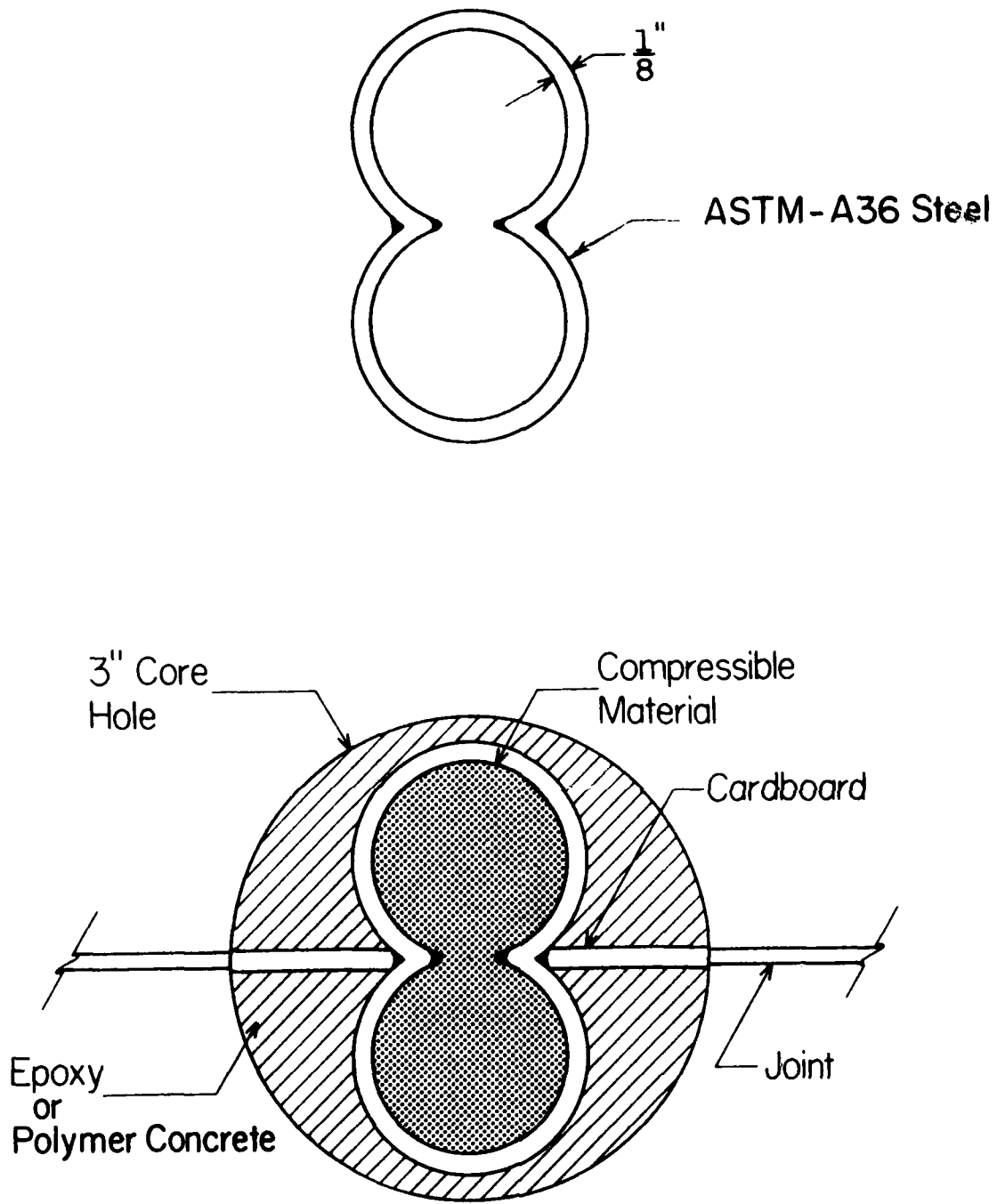

Figure 5. "Figure-eight" Load Transfer Device (French Connection)

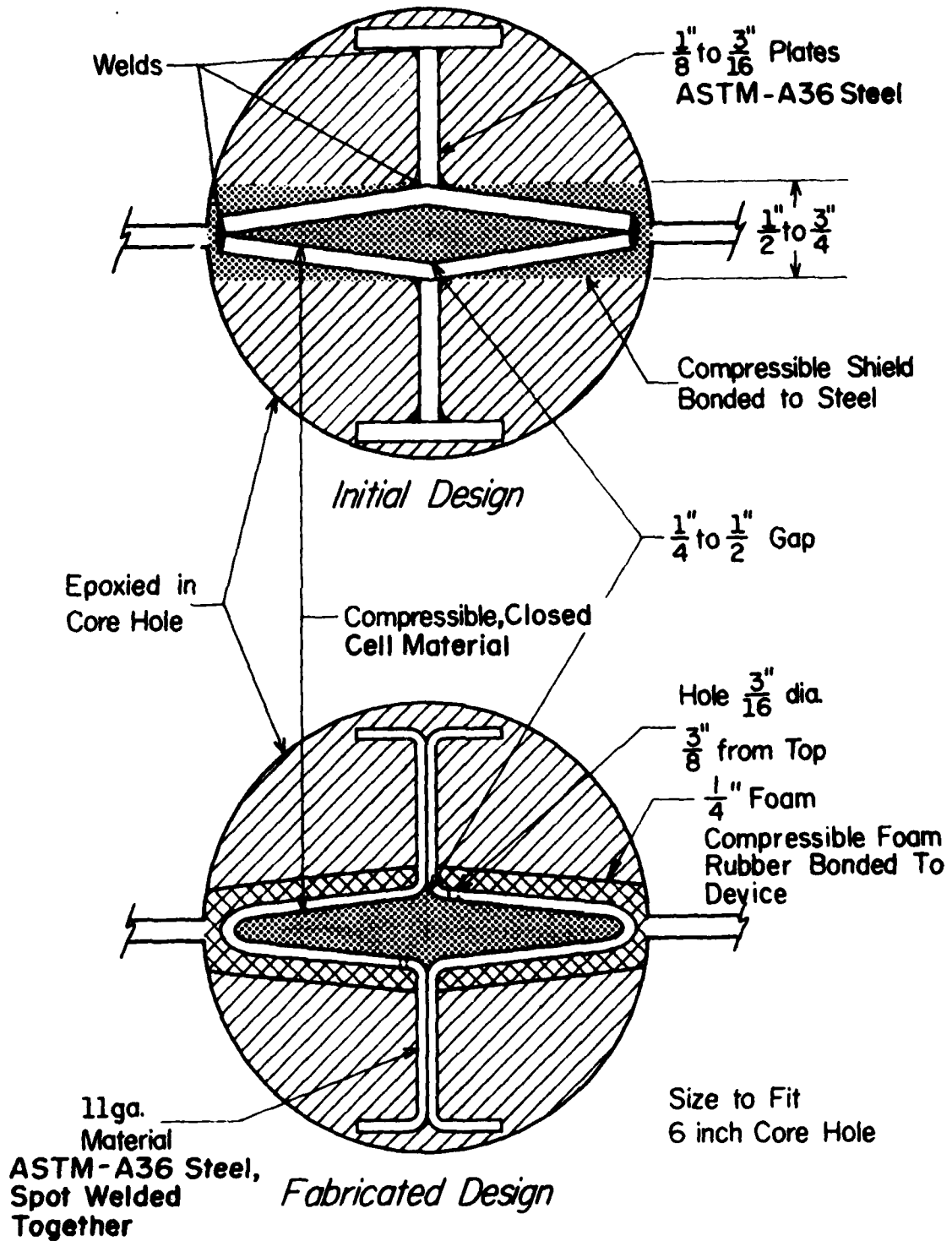
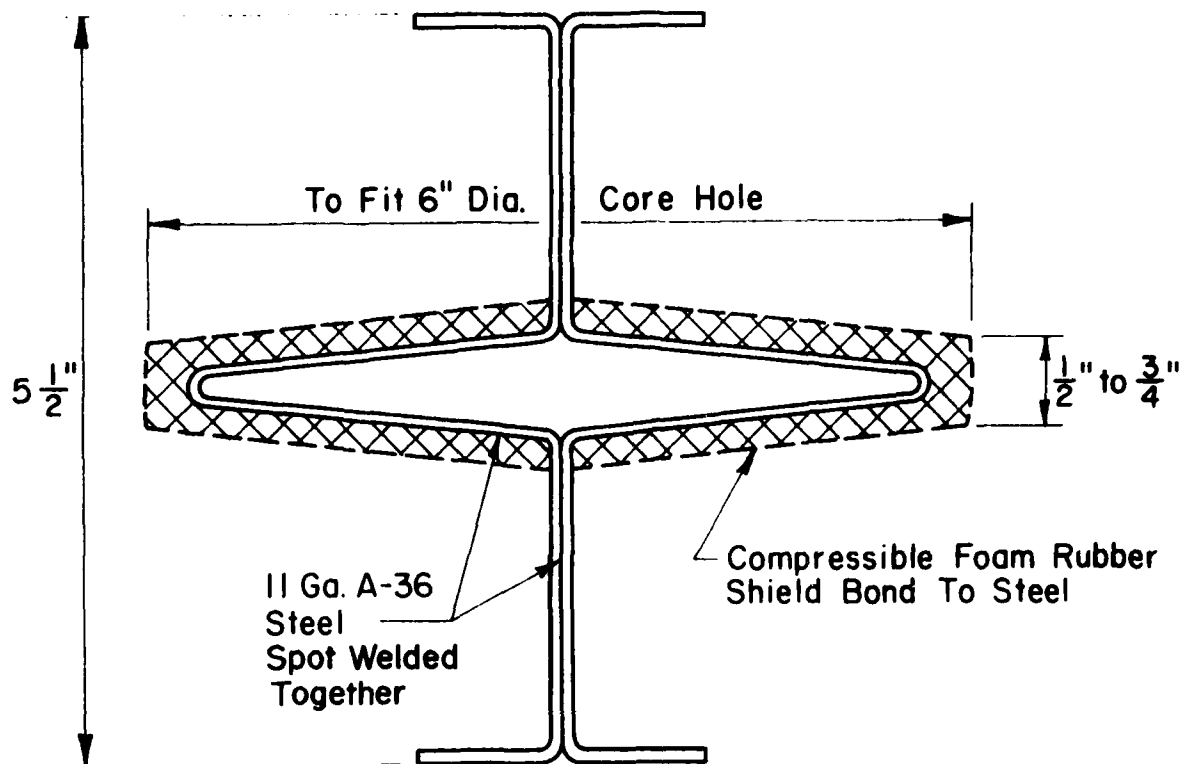

Figure 6. Initial and Fabricated Versions of Diamond Device  
Developed at University of Illinois (U. of I.)



A-36 Steel, Hot Dipped In Epoxy Material To Prevent  
Corrosion  
Length To Match Slab Thickness

## U of I Load Transfer Device

Figure 7. Intermediate Version of U of I Device.

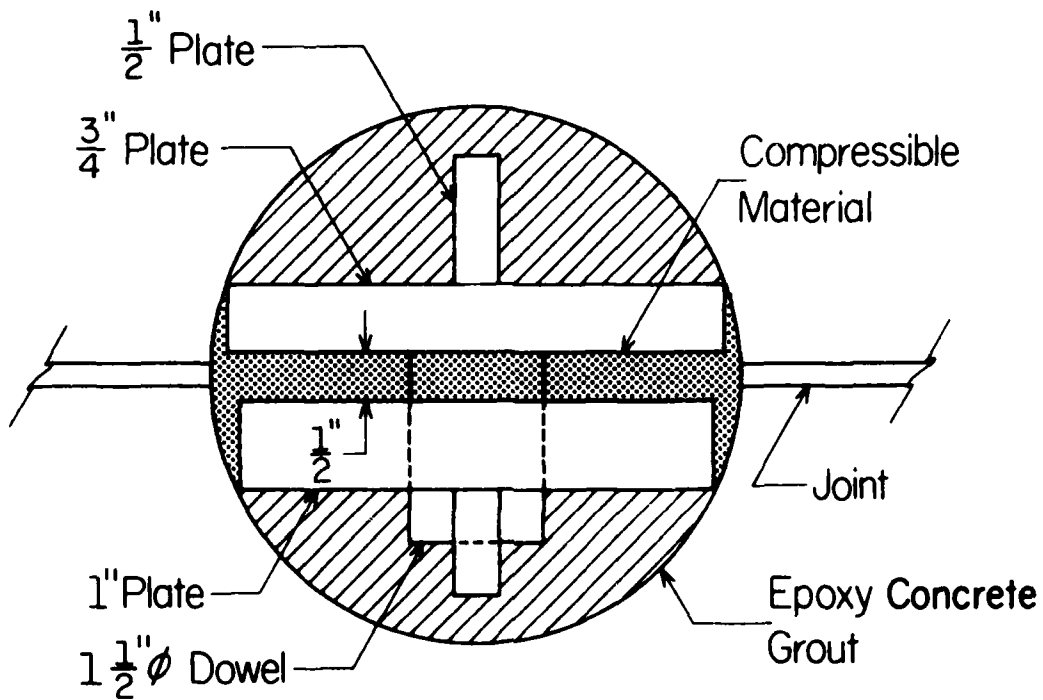

Figure 8. Plate and Stud Load Transfer Device.

device was designed to transfer shear and moment across the joint while also allowing for the free horizontal movements of the slab. The device would be installed with one-fourth inch space between the plates through the installation of a compressible spacer.

These three types of load transfer devices were examined using several different tests to evaluate their effectiveness and performance. The series of tests included a compression test, a tension test, a shear test, a moment test and a fatigue test. Not all tests were performed on all three devices. The diamond shaped device was subjected to all of the tests, and was modified partially as a result of test results and partially to facilitate fabrication to the device shown in Figure 6. Basically the device as fabricated is the same except the diamond portion was fabricated out of two plates shaped with a "V" and flange and welded together. Steel used in the fabrication was a mild steel meeting the ASTM specifications for A-36 steel. The revised device was tested for load transfer effectiveness, flexibility and fatigue and found to be fully as effective as the original design. Details of each test conducted on the devices are described below.

#### Test Specimens

All of the specimens were assembled using identical procedures and identical grouts. Figure 9 shows the two 15" x 16" x 8" concrete blocks, with an average unconfined compressive strength of 8000 psi, clamped together and core drilled through the slabs across the joint. Core diameters used were either 3 inch or 6 inch diamond core bits, the size depending upon the size device to be tested. Devices were inserted in the core hole and grouted with grout made from Concretive<sup>R</sup> epoxy and Ottawa sand. After 3 days of curing at 75°F failures always occurred in the PCC rather than in the grout.

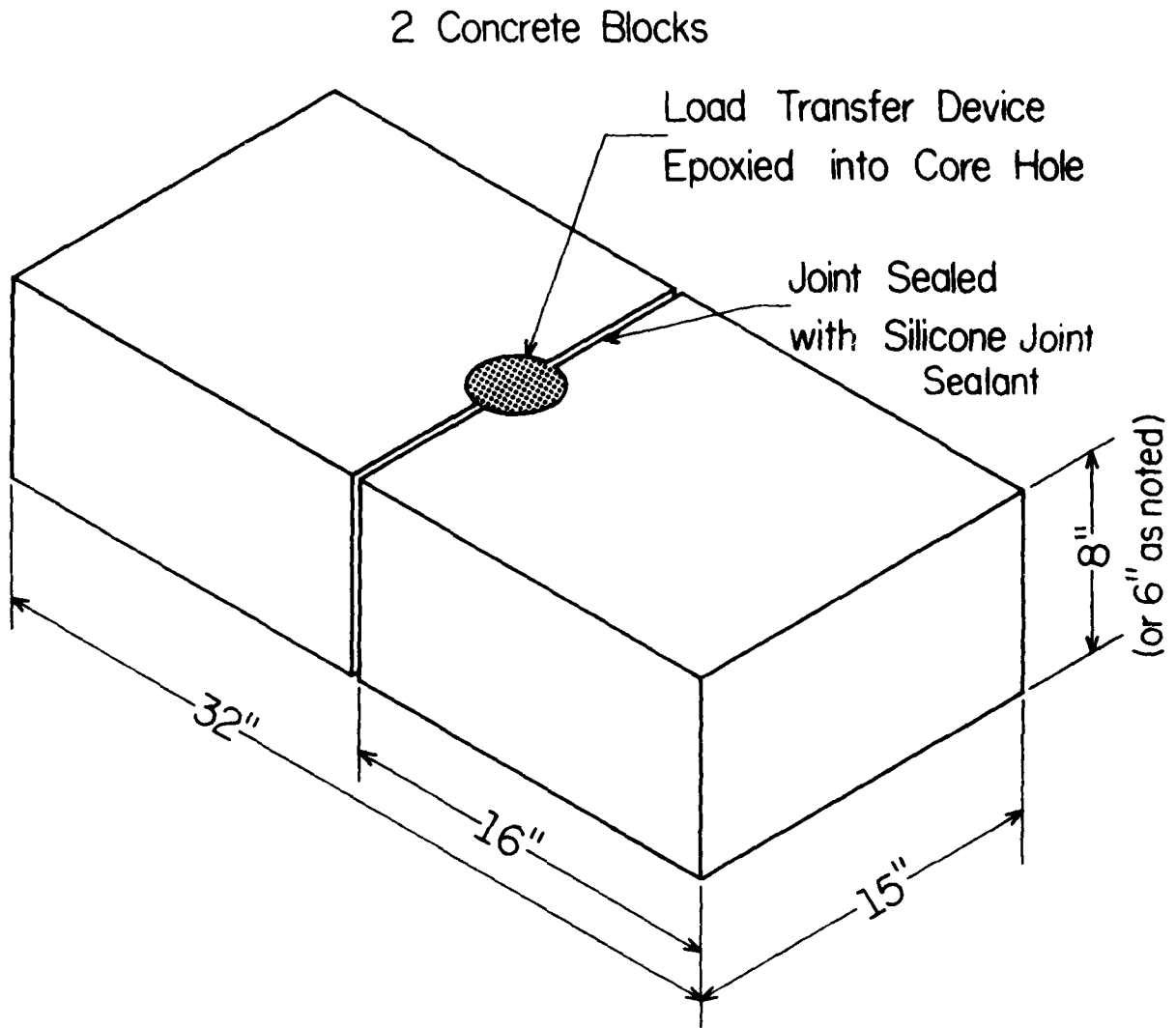

Figure 9. Concrete Block Test Specimens Used to Evaluate Load Transfer Devices in Laboratory. (Same Type of Block Used for All Types of Tests)

### Compression Test

One size of the figure-eight (French) device and two sizes of diamond shaped (U of I) device were tested under direct compression to determine the magnitude of load required to close the devices such as during the closing of the joint. Load deformation curves were developed for each of these devices tested.

### Tension Test

The figure-eight and diamond shaped devices were tested for resistance to joint opening by installing each of the devices in concrete blocks and testing in tension as shown in Figure 10. Load deflection curves were developed for these devices.

### Shear Test

All three types of devices were tested under shear loading to determine their load transfer characteristics. Figure 11 illustrates the shear test procedure. As shown, jointed concrete blocks with the load transfer devices installed were supported at three points; near each end, and near one side of the joint. A load was then applied to the slab which was not supported near the joint. Deflection gages were used to measure the absolute deflection of the joint and relative deflection across the joint during loading.

Two sets of the shear test data were collected. One set compared a three inch diameter version of the figure-eight device with the three inch diameter version of the diamond device. The second set of tests compared the effectiveness of a six inch diameter version of the diamond device with the six inch dowel and plate device used by Brandley.

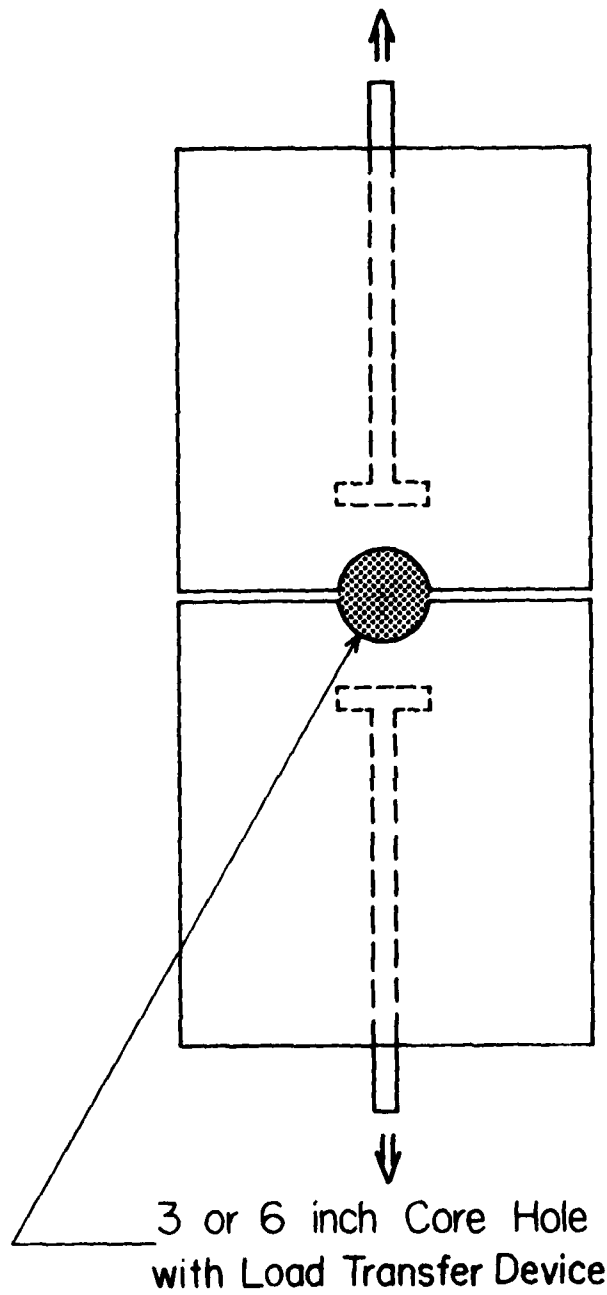

Figure 10. Schematic of Tension Test to Evaluate Resistance to Joint Opening.

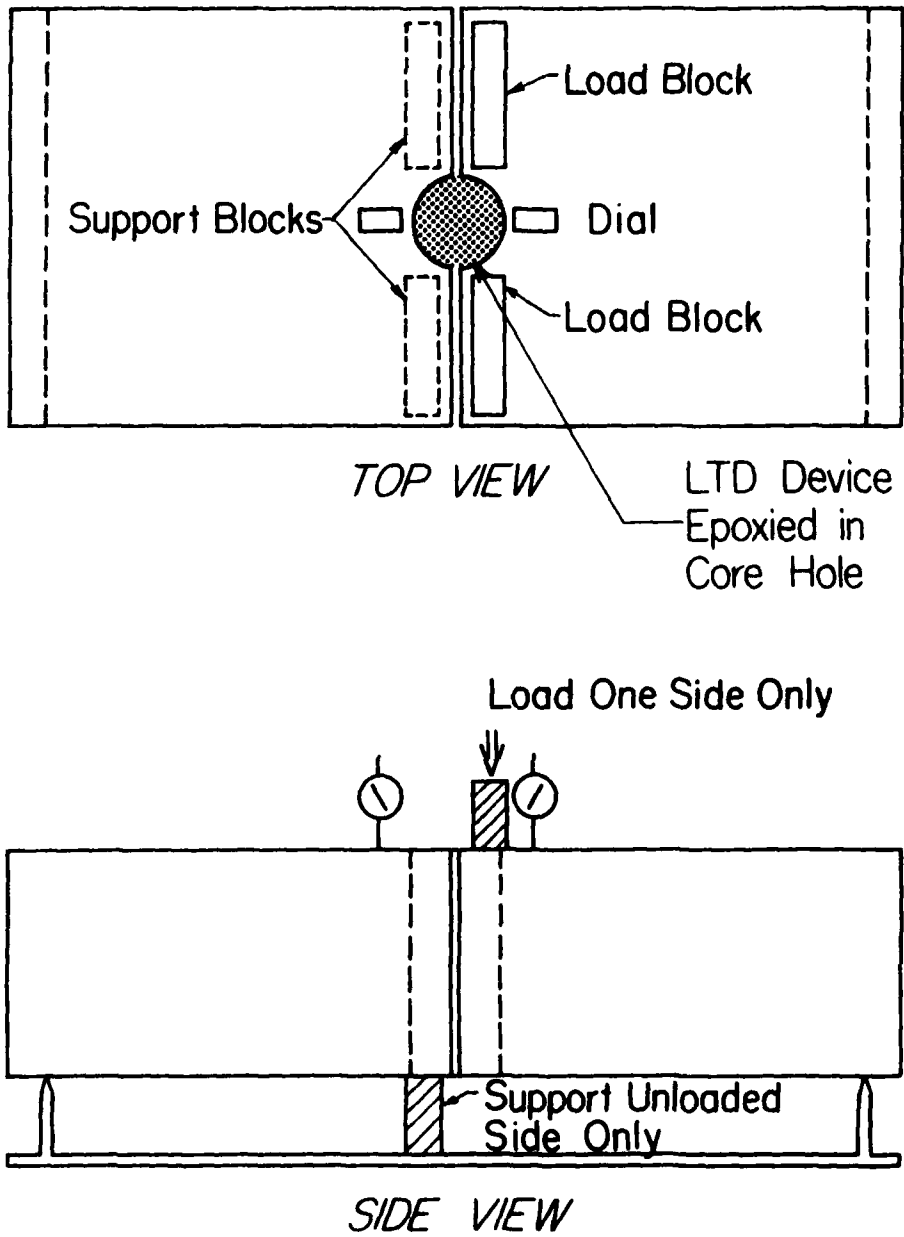

Figure 11. Shear Test to Measure Load Transfer Effectiveness.

### Moment Test

Concrete block test specimens, each containing a figure-eight device or a diamond device of the size to fit into a 3 inch diameter core hole, were tested under a pure moment. The specimens were assembled in the same manner as for the shear test but loaded as shown in Figure 12. The concrete blocks were supported near each end and loaded at approximately seven inches away from and on both sides of the joint. Dial gauges were used to measure the deflection of the specimens during loading.

### Fatigue Test

Both the figure-eight and diamond devices were tested under repeated loads. A section of pavement was constructed as shown in Figure 13. For the smaller (3 inch diameter) devices four equally spaced cores were drilled along the joint between two concrete slabs 4 feet wide by 7 feet long by 4 inches thick. The slabs were placed on a neoprene rubber pad to simulate a subgrade with an approximate soil support value "k" of 250 pci, based on tests with a 30 inch diameter plate. The load transfer device to be tested was installed in each of the four holes, grouted into place, and allowed to cure for three days at room temperature. Deflection gauges supported outside the test area were placed on both sides of the joint. Repeated loads were applied to the slab for each device on one side of the joint. For the first 300,000 cycles, a repeated load of 10 kips was applied. From 300,000 to 1,300,000 cycles the load was increased to 20 kips, and after 1,300,000 cycles, a 25 kip load was used. These load magnitudes were selected on the basis of a percentage of the anticipated ultimate load of the load transfer devices.

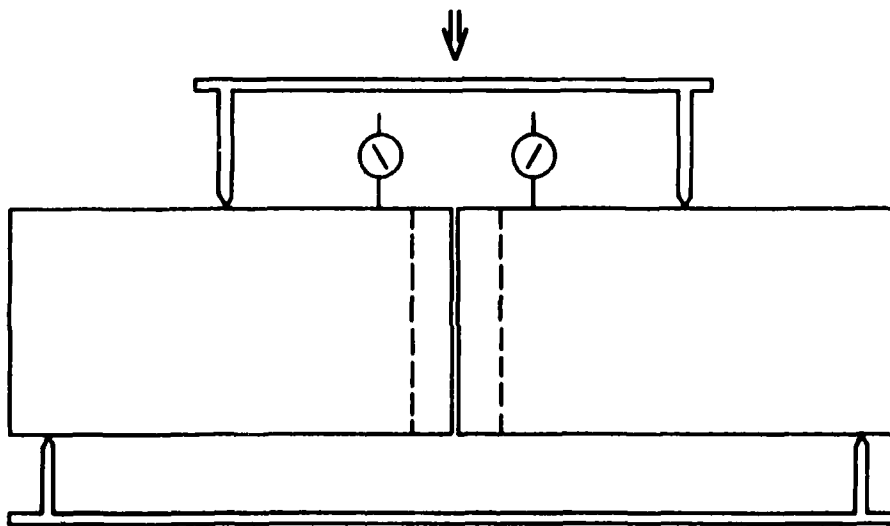
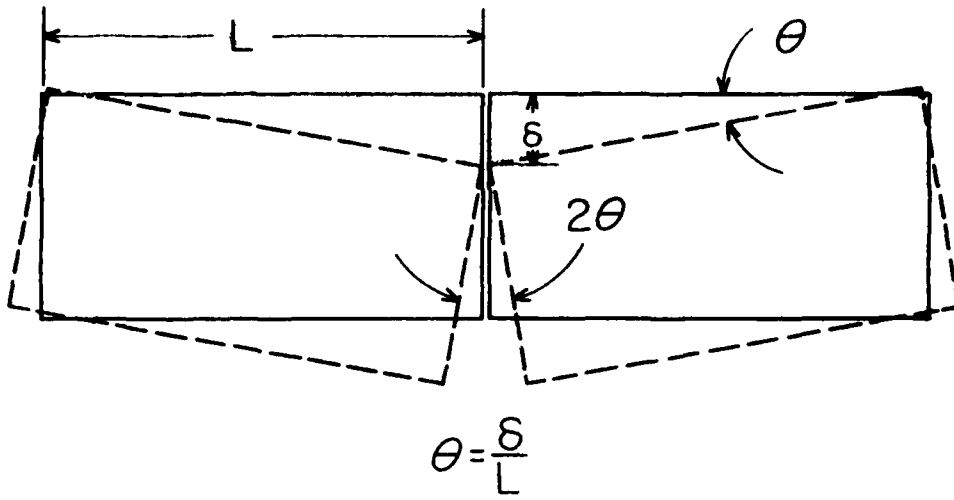

*SIDE VIEW*

Figure 12. Test Setup for Moment Test with LTD,  
Load Transfer Device

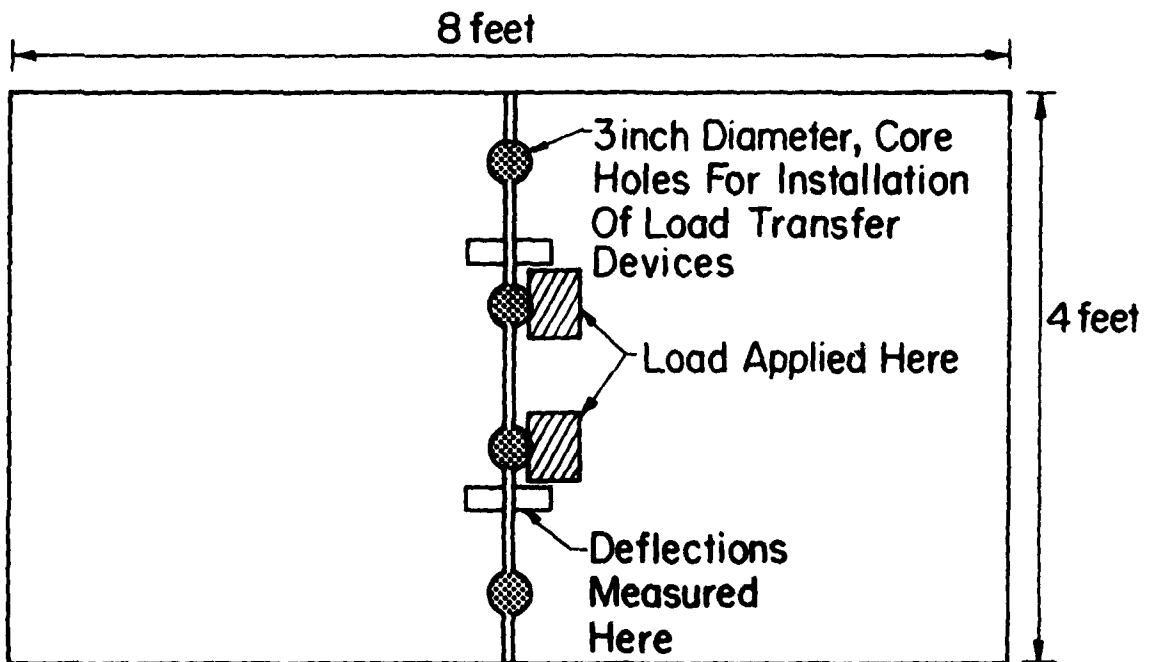

TOP VIEW

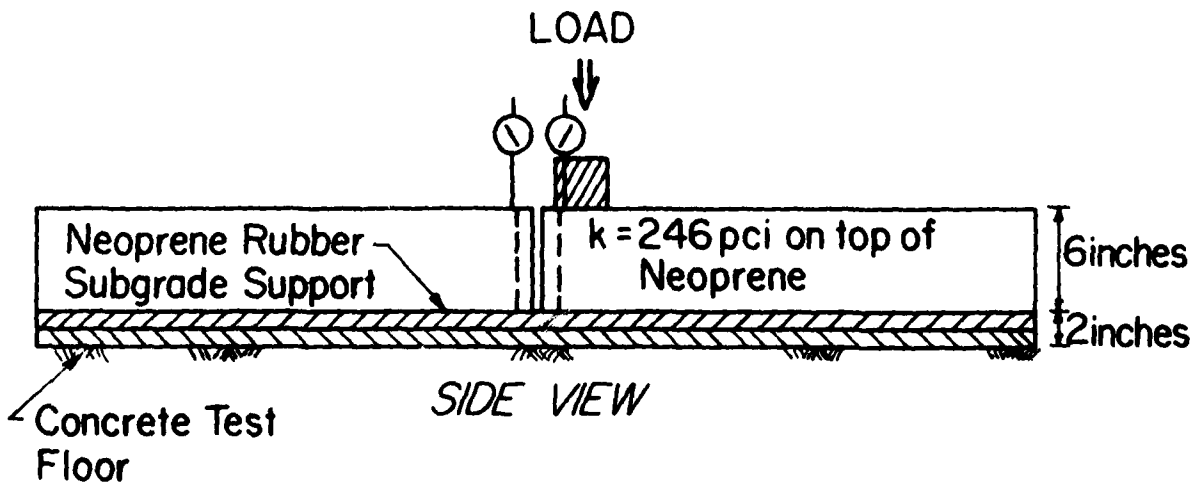

SIDE VIEW

Figure 13. Fatigue Test Setup for Three inch Size Figure 8 and Diamond Devices.

A similar test procedure was used to test the 6 inch diamond device except that the test specimen was 15 inches wide, 6 inches thick and only one device installed per specimen.

## CHAPTER 4

### PRESENTATION AND DISCUSSION OF LABORATORY TEST RESULTS

All load transfer devices tested transferred load in an efficient and effective manner. Some of the devices did not permit free opening and closing of the joints and so were judged less desirable than others. A summary of the test results is presented and discussed below.

Resistance of the load transfer device to joint opening and closure was measured using the direct tension test as shown in Figure 10. This test was conducted only on the figure-eight and diamond shaped devices, but both the three and six inch size of the diamond shaped device were tested. Load deflection curves for these two devices are shown in Figure 14. The greater flexibility of the diamond shape is clearly seen in these curves. Furthermore, the diamond devices which fit into six inch diameter core holes were less resistant to joint opening and closing than the three inch size. Some initial bonding between the diamond device and the grout caused an initial resistance to joint opening, but as soon as this bond was broken the load deflection curve became nearly constant as shown in Figure 14.

To validate the above results both the figure-eight and diamond shaped devices were tested in compression. This test was run on the three inch size of the diamond shaped device. Results of these tests are shown in Figure 15. The relative flexibility of the two devices is clearly seen in these data. The increased flexibility of the larger diamond device over the smaller size is also seen in the results.

The less flexible load transfer systems is also demonstrated in the pure bending test illustrated in Figure 12. This test was conducted on

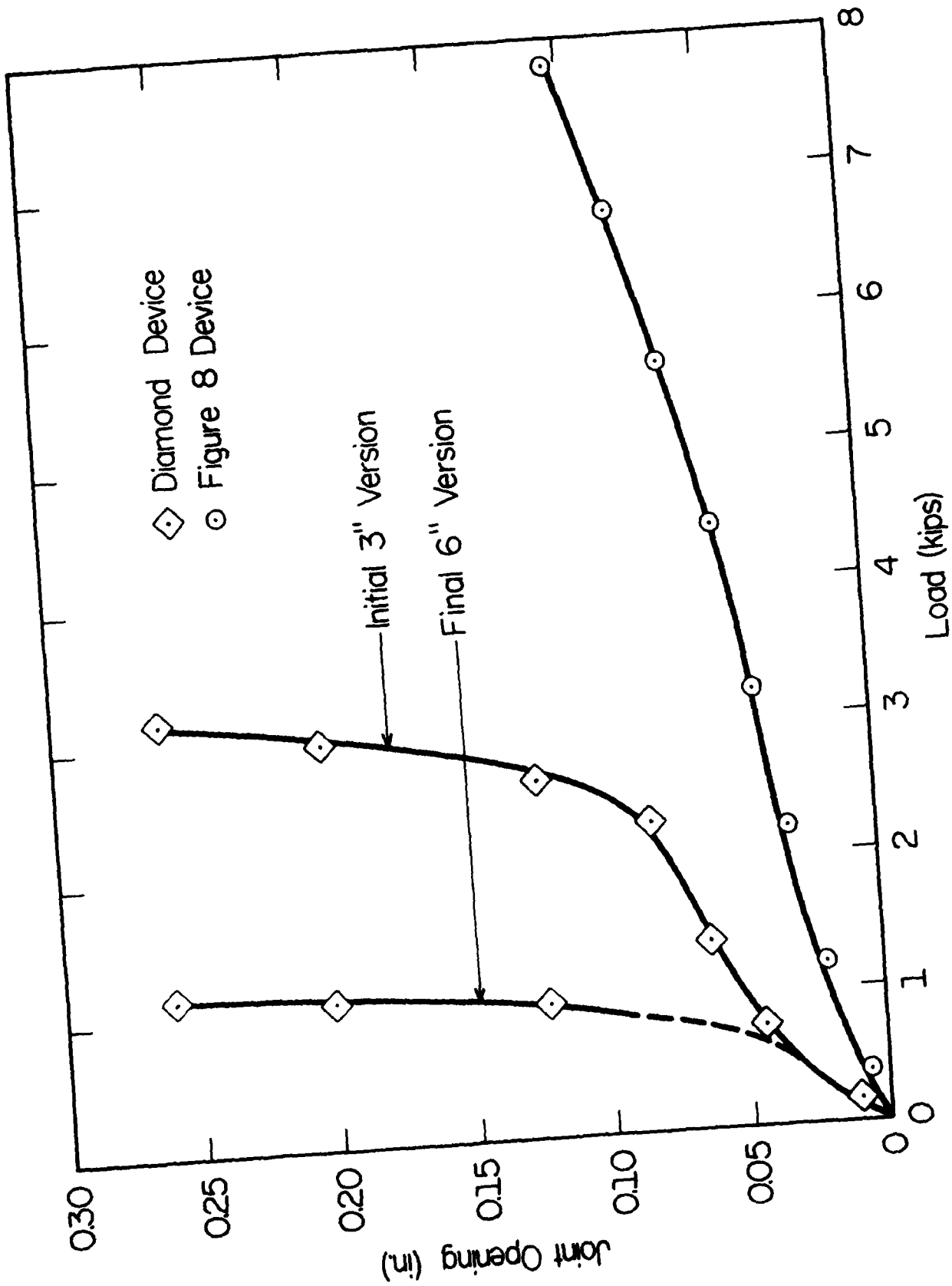

Figure 14. Load versus Joint Opening in Direct Tension for Various Load Transfer Devices.

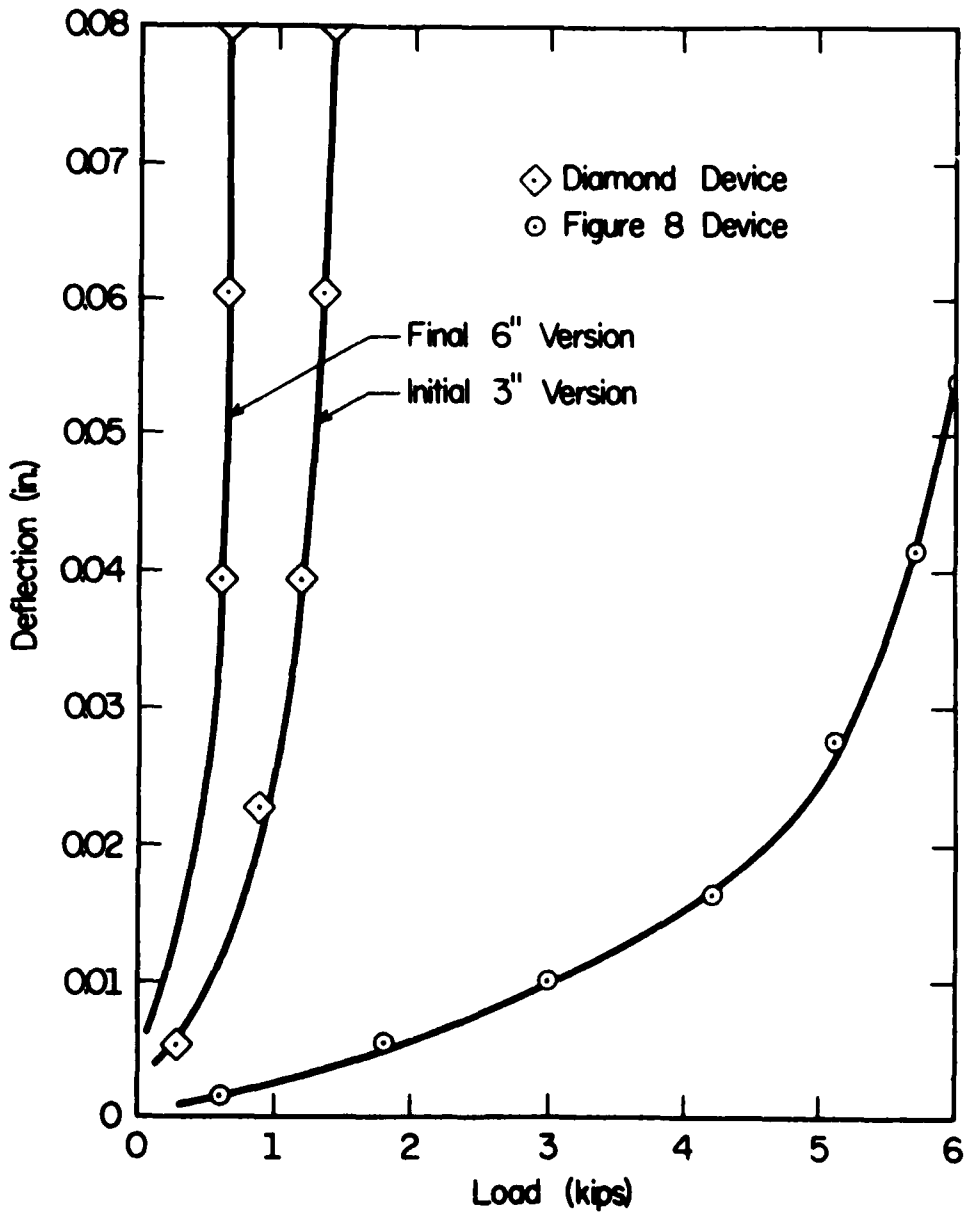

Figure 15. Load versus Closure of Load Transfer Devices Tested in Compression.

only the figure-eight and diamond shaped devices to fit the three inch diameter cores. Results of these tests are shown in Figures 16 and 17. Figure 16 shows the deflection versus load for specimens tested in bending with both the figure-eight and diamond shaped device. For comparison only, the theoretical deflection of a comparable size beam with no joint is also shown in Figure 16.

Figure 17 shows the relative rotation at the joint as a function of the applied load. A description of this rotation is illustrated in Figure 12. The results in Figures 16 and 17 verify the increased flexibility of the diamond shaped device over the figure-eight device. The six inch size diamond shaped device was not tested in pure bending as the specimens did not have sufficient rigidity against bending to conduct a meaningful test.

The above tests were run simply to get a feel for the resistance to joint opening and closing provided by the different devices. It should be recognized that a device can effectively transfer load even if it does not provide for free opening and closing of the joints. How important the resistance to joint opening and closing is will depend on the length of pavement being tied together, and the temperature differentials anticipated in the pavements.

The most important quality of a load transfer device is its ability to efficiently transfer load across the joint by shear action. This is properly demonstrated by the results from the direct shear test and the slab fatigue tests. Data from full scale field tests are also available to demonstrate the effectiveness of the load transfer systems.

Test procedure for the shear test is shown in Figure 11. Results from the direct shear tests are shown in Figure 18. The results show that

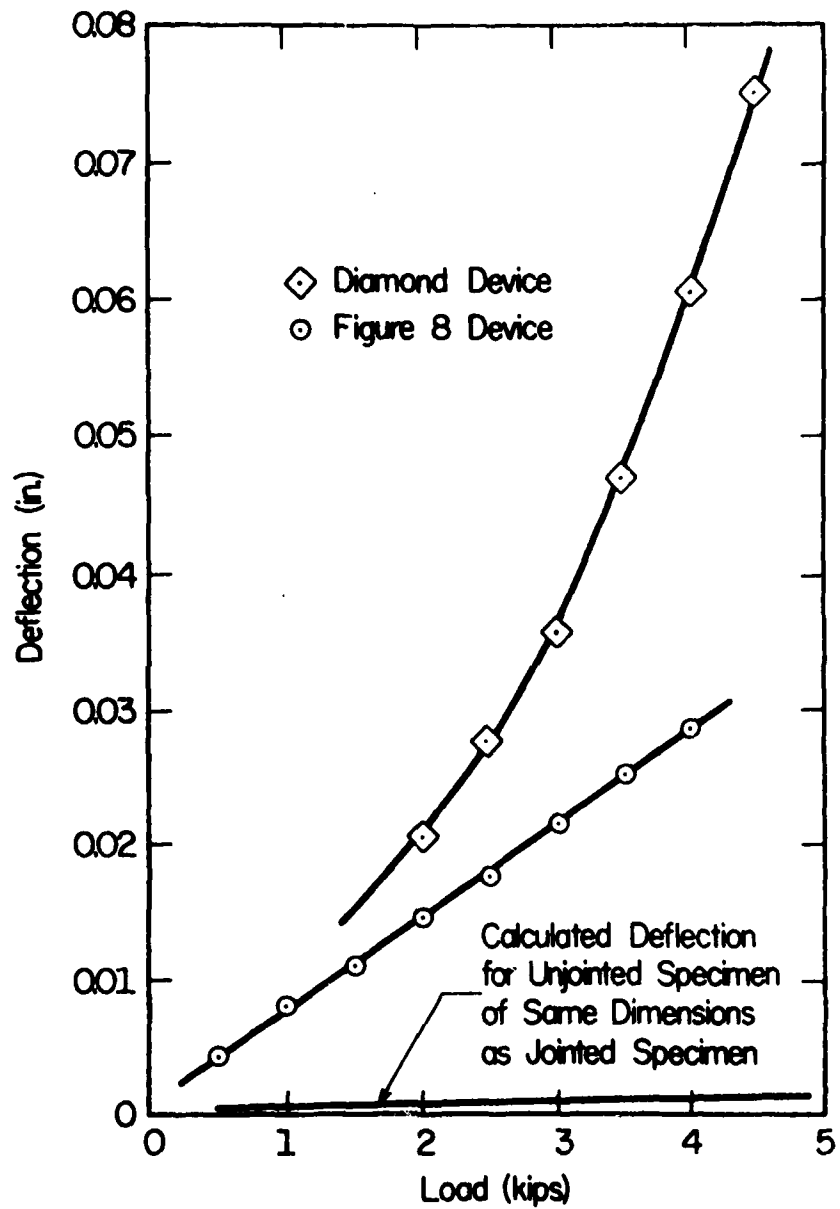

Figure 16. Deflection versus Load for Jointed Blocks with Load Transfer Devices Tested in Bending.

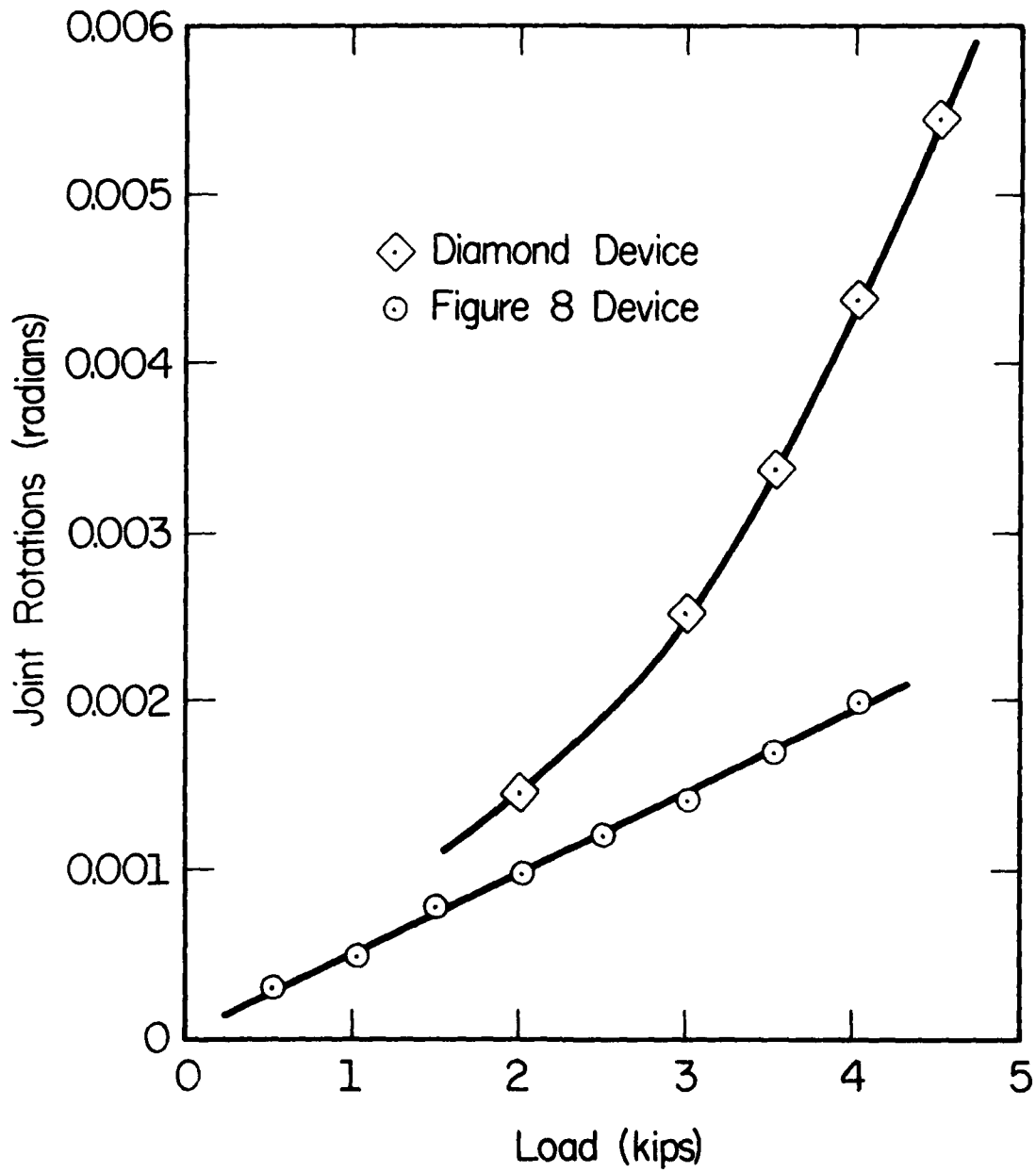

Figure 17. Joint Rotation with Figure Eight and Three inch Diamond Devices.

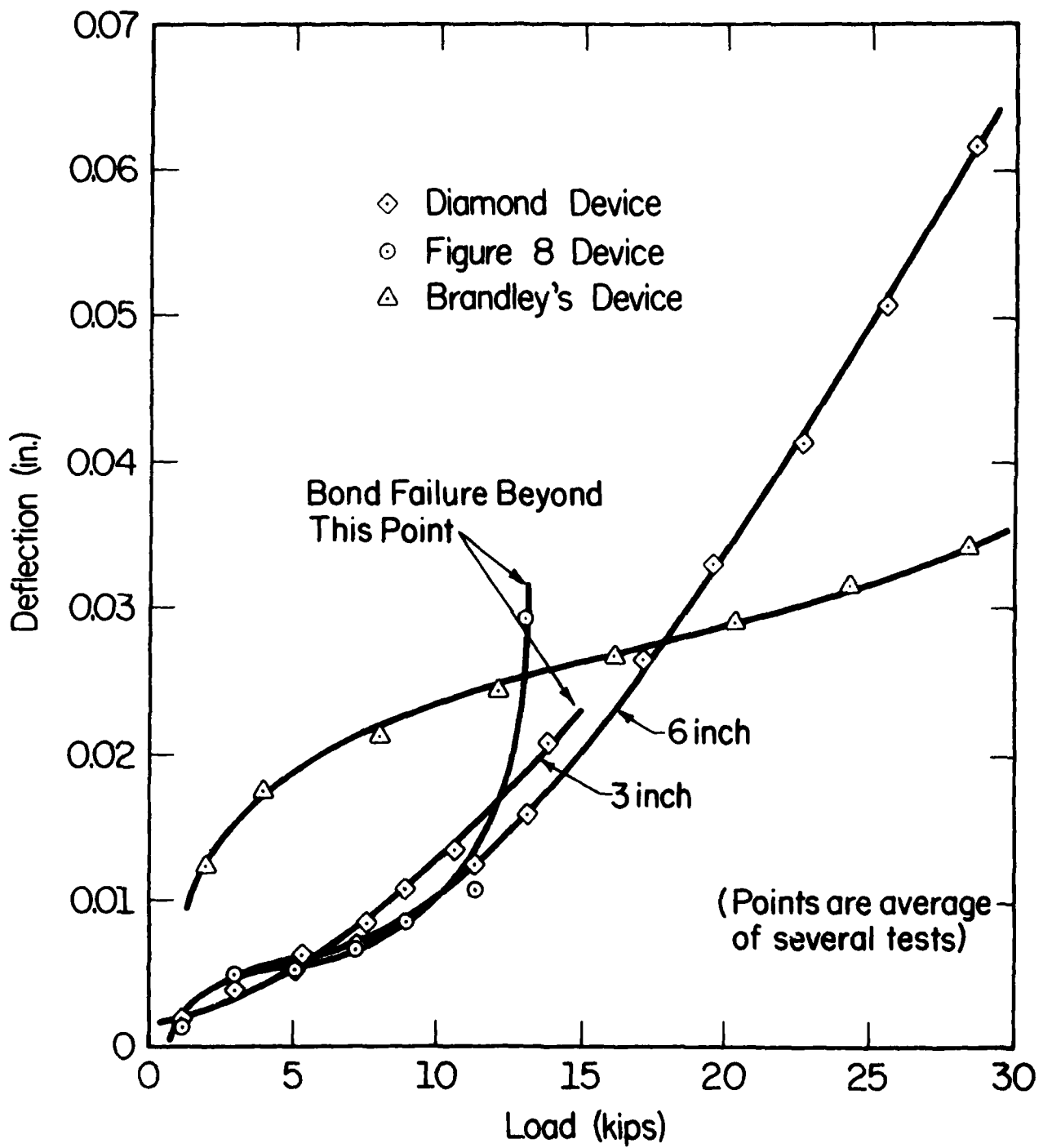

Figure 18. Results from Shear Tests on Blocks with Load Transfer Devices.

the figure-eight, the diamond and the plate and stud devices were all very effective in transferring load across a joint. These joints when loaded to failure all failed in the concrete around the perimeter of the curve hole rather than failing the devices or the grout. The load transfer ability of these devices can be estimated by calculating the shear strength of the concrete around the perimeter of the core hole. On this basis, the six inch device would be twice as strong as the three inch device for the same slab thickness. Actual failures of the three inch devices when tested in pure shear ranged between 12,500 and 14,800 pounds while the specimens with the six inch devices tested in shear failed at loads which ranged between 26,000 and 30,000 pounds. As indicated, all failures were in the concrete around the core holes rather than failure of the devices or the grout.

Fatigue tests were run by installing load transfer devices in model slabs 4 inches thick and applying cyclic loads on one side of the joint as shown in Figure 13. The magnitude of the load was increased incrementally from approximately the design load for the device up to over twice the design loads. Only the figure-eight and diamond devices were tested in fatigue.

Results from the fatigue tests are shown in Figure 19 and 20. The data show that both devices carried several million applications of the design load without loss of effectiveness. The small diamond devices showed evidence of fatigue failure at the welds at the tips of the diamond before complete failure. The six inch diamond devices as currently manufactured do not have the weld along this point and this point of weakness has been eliminated. Several 6 inch devices have been tested

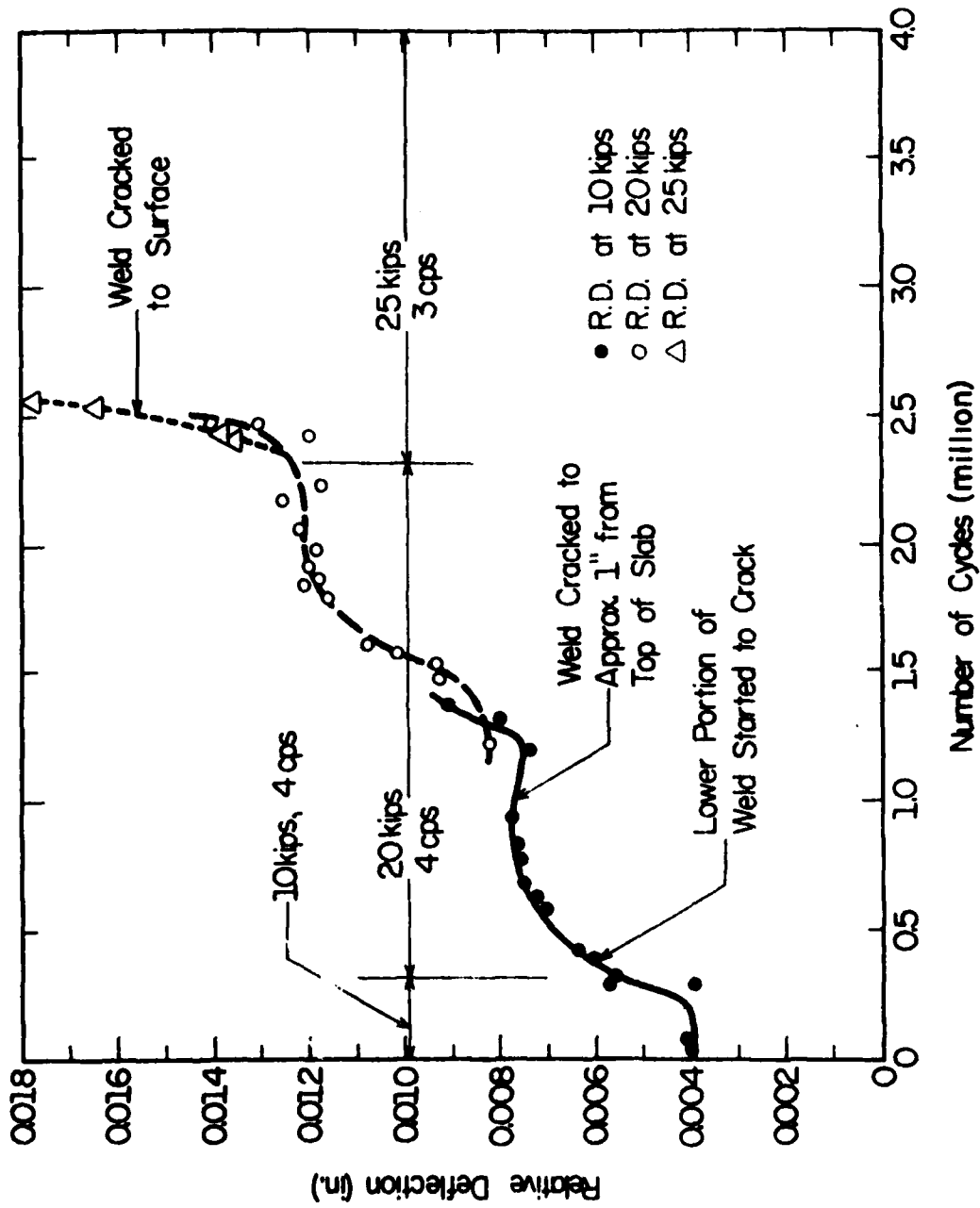

Figure 19. Fatigue Performance of Welded 3 inch Diamond Device.

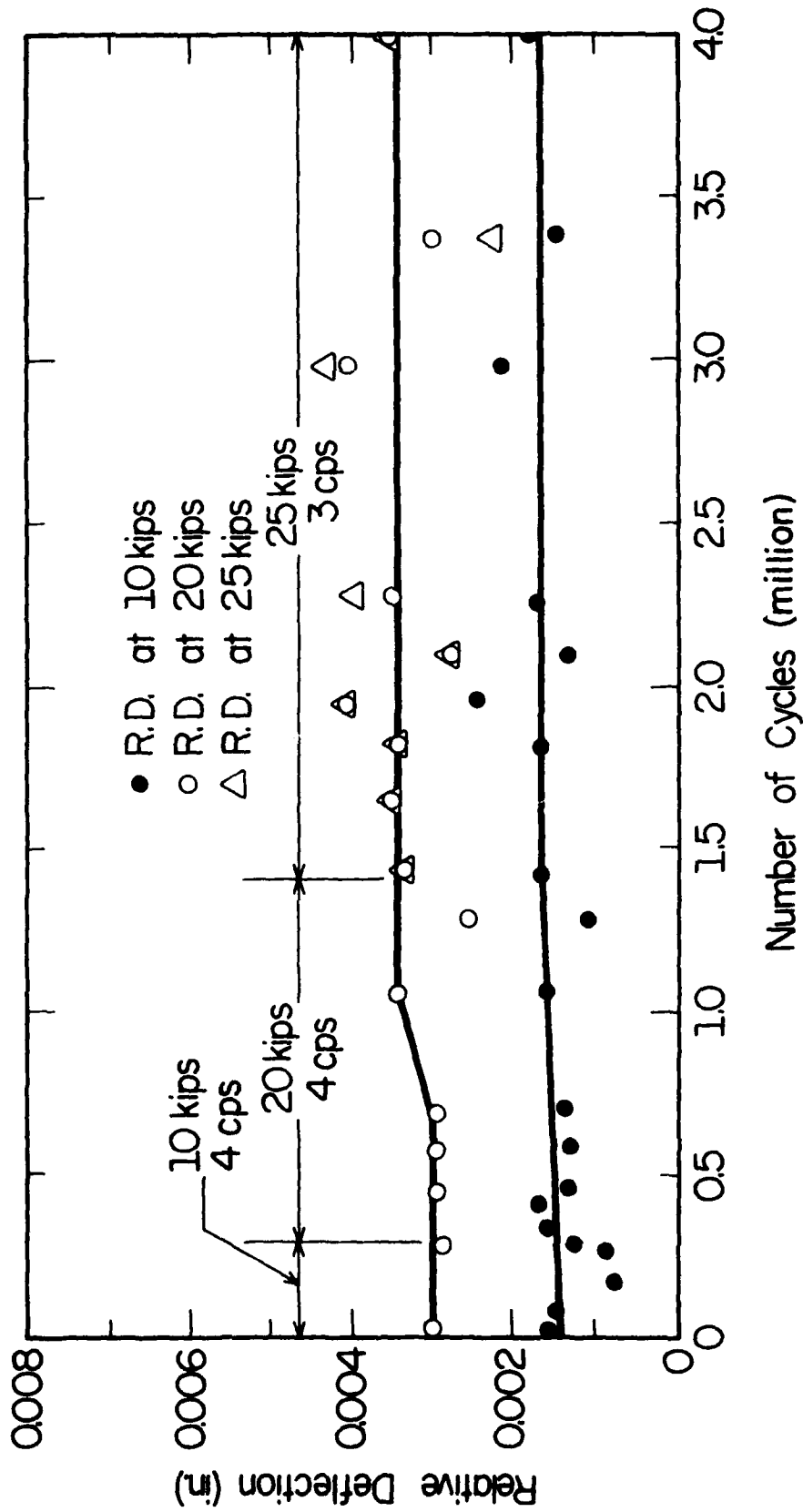

Figure 20. Fatigue Results from Model Slabs with Figure Eight Device.

under repeated loads of 25,000 pounds for over 4 million repetitions without failure.

The figure-eight device tested in fatigue did not show any evidence of fatigue failure even after 4 million repetitions of a load that was well in excess of design loads for that size device.

## CHAPTER 5

### FIELD TESTS ON LOAD TRANSFER DEVICES

Data are available from several field installations on the effectiveness and performance of various load transfer systems. Earlier in this report some specific examples were given on the performance of doweled and tied longitudinal transverse joints. Butt joints and their effectiveness were also discussed. In these results it was noted that for light loads the pavements with untied butt joints gave satisfactory performance, but as the magnitude of load increased the need for load transfer also increased. It was also noted that the joints with dowels and heavy tie bars as load transfer devices have performed well in service as long as sufficiently large dowels or tie bars are used. Reference 2 provides guidelines for the design of dowels to prevent dowel socket deterioration.

The effectiveness of the diamond and plate and stud load transfer devices under full scale testing was demonstrated by tests at the San Diego Airport (13). Both types of device were installed at a number of joints of a 12 inch thick jointed concrete pavement at the airport (a total of over 12,000 devices installed at San Diego). The relative deflection across the joints both before and after installation of the devices was measured. These tests were run with 55,000 pound wheel load moving across the joints. The relative deflection across the joints as the wheel crossed was measured with linear transformers attached to a beam resting on the slab away from the loaded area. In each test the wheel is moving perpendicular to the joint and crosses it at right angles. The test procedure is shown in Figure 21. Typical results from these field tests are shown in Table 5.

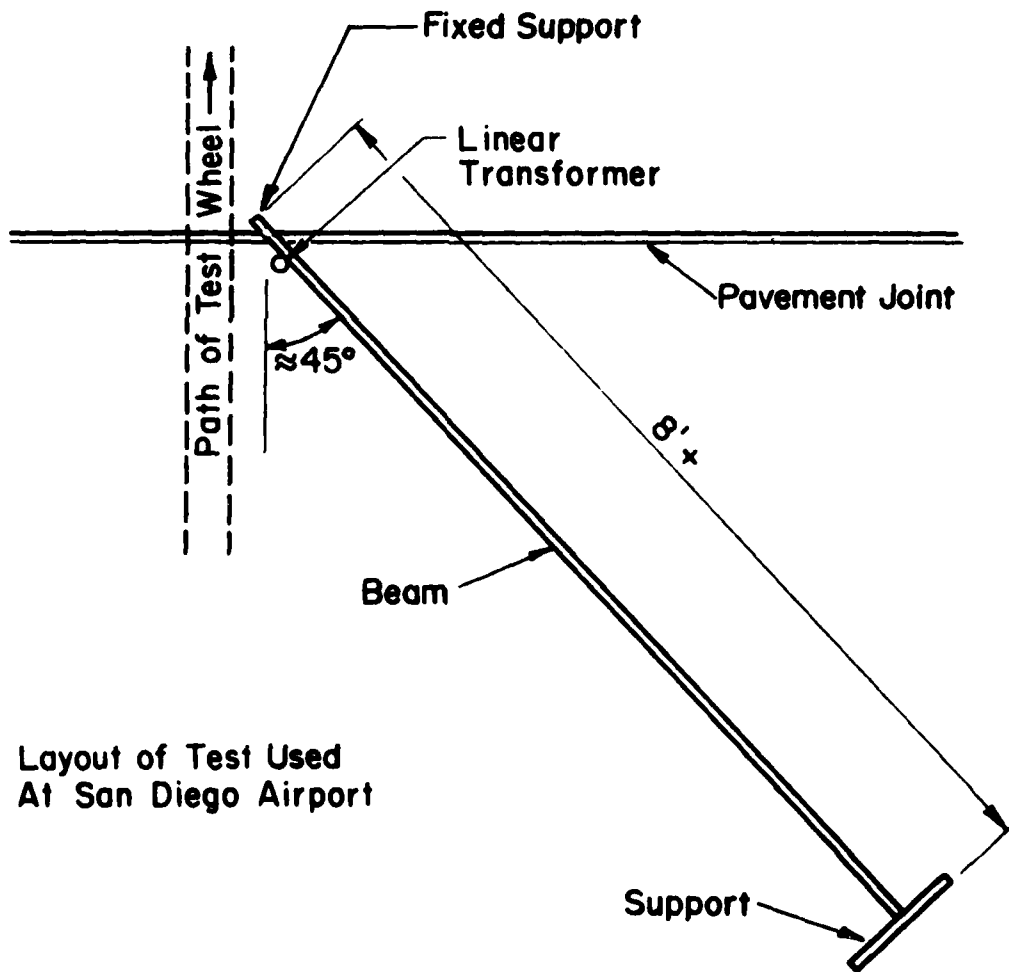
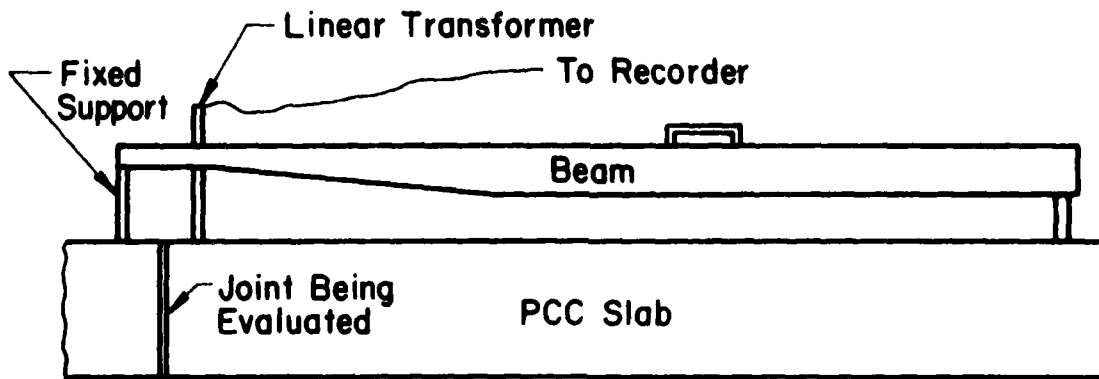

Layout of Test Used  
At San Diego Airport

Figure 21. Test Beam and Schematic of Field Test Procedure for Measuring the Relative Deflection across Joints.

Table 5. Results from Field Tests at San Diego Airport  
by Brandley (13)

Type Device	Deflection, inches		
	Before Repair	After Repair	
		First Pass	200th Pass
Diamond	.050	.001	.001
Diamond	.058	.004	.003
Plate & Stud	.035	.003	.001
Plate & Stud	.043	.001	.002
Plate & Stud	.025	.003	.003
Plate & Stud	.035	.005	.004

As further evidence of the effectiveness of the load transfer devices in arresting distress in these pavements, it was noted that between the time of the initial survey on the pavements and installation of the load transfer devices, a period of approximately 3 months, 61 additional slabs cracked due to the normal use of the pavements. After installation of the load transfer devices, under nearly 4 months of usage under the same traffic, no additional cracked slab was found (13). These two sets of information strongly suggest the load transfer devices were effective in reducing relative deflections across the joints and the load transfer provided by the devices also significantly increased the potential performance of these pavements.

The long term effectiveness of these load transfer devices cannot be established at this time. It is believed that the primary cause of failure with these devices will be a failure of the concrete adjacent to the grout used to install the devices. There are examples where effective bond between polymer concretes and Portland Cement

Concrete has lasted for many years (5 to 8 years) under field service conditions. Only long term, carefully monitored studies of field installations will verify these findings.

## CHAPTER 6

### COST

Information was collected on the relative cost of manufacturing and installation of the various load transfer systems. These prices are based on the actual costs of installation of the types of load transfer discussed. Obviously, for those joint systems which were proposed but never constructed, no cost data are available. Also, for butt joints with no load transfer, the cost is assumed to be nil. Based on this survey of actual installation costs, it is apparent that there is a wide range in the prices. Some general guidelines on costs can be established, but these are of limited value as costs change quickly as the technology improves. Costs for these devices are broken into two parts: the manufacturing cost and the installation costs. These are summarized in Table 6.

Based on the prices cited in Table 6 the total cost of the various devices installed are summarized in Table 7. To fully evaluate the cost it is necessary to take into account the spacing of the different devices. Dowels and tie bars recommended for load transfer devices are normally spaced at 12 inch intervals. The plate and stud and the diamond devices are spaced at about 30 to 36 inch intervals depending on the slab thickness ( $2/3$  to  $3/4$  the radius of relative stiffness of the slab is preferred). With these spacings the cost per foot of joint for the dowels and tie bars placed in the plastic concrete will range from \$2 to \$4, for the plate and stud device will range from \$35 to \$50 per foot, and for the diamond device from \$16 to \$25 per foot. Obviously, the dowels and/or tie bars inserted into plastic concrete are the most economical solution.

Table 6. Summary of Costs for Installation of Various Load Transfer Systems

Load Transfer Device	Manufacturing Costs (each)	Installation Costs (each Device)	
		Procedure 1 <sup>a</sup>	Procedure 2 <sup>b</sup>
Dowels			
1-1/4" x 18"	\$1.50 to \$2.00	\$0.10	\$3 to \$5
1-1/2" x 20"	\$2.00 to \$2.50	\$0.10	\$3 to \$5
2" x 24"	\$3.50 to \$4.00	\$0.13	\$3 to \$6
Tie Bars			
1" x 24"	\$1.00 to \$1.40	\$0.10	\$3 to \$5
1-1/4" x 30"	\$2.10 to \$2.75	\$0.10	\$3 to \$5
1-3/8" x 36"	\$2.50 to \$3.25	\$0.10	\$3 to \$5
Plate and Stud Device	\$45 <sup>c</sup>	\$40 to \$60 <sup>c</sup>	
Diamond Device	\$12 to \$18 <sup>d</sup>	\$35 to \$45 <sup>e</sup>	
Figure-eight Device	Not available	\$35 to \$45 <sup>f</sup>	

<sup>a</sup> Dowels and tie bars inserted into plastic concrete using pneumatic ram.

<sup>b</sup> Dowels and tie bars inserted in drilled holes in hardened concrete and epoxied in place.

<sup>c</sup> Based on cost for 12,000 devices for the San Diego Airport.

<sup>d</sup> Based on fabrications cost estimate for devices 8 to 15 inches long.

<sup>e</sup> Based on estimated costs on installation in an 8 inch slab in Georgia and a 12 inch slab in Utah.

<sup>f</sup> Engineer's estimate.

Table 7. Total Estimated Cost of Various Load Transfer Systems

	Inserted in Plastic Concrete	Drilled and Grouted
Dowels		
1-1/4 inch Dia.	1.60 to 2.10	4.50 to 7.00
1-1/4 inch Dia.	2.10 to 2.60	5.00 to 7.50
2 inch Dia.	3.65 to 4.15	6.50 to 10.00
Tie Bars		
1 inch Dia.	1.10 to 1.50	
1-1/4 inch Dia.	2.20 to 2.85	
1-3/8 inch Dia.	2.70 to 3.35	
Plate and Stud Device	\$88 to \$105	} Installed by coring and grouting with polymer concrete
Diamond Device	\$47 to \$63	

Some adjustments will be needed, however, at the intersection of the longitudinal and transverse joints because of the potential interference between the bars in the intersecting joints and the need for the most effective load transfer at these locations.

CHAPTER 7  
RECOMMENDATIONS AND CONCLUSIONS

Recommendations

Based on the relative effectiveness of the various devices, and the cost per foot installed, the joint systems given in Table 8 and in Figures 22, 23 and 24 are recommended for airport pavements based on the anticipated aircraft using the facility. With these recommendations it is assumed that stabilized subbase of sufficient thickness to serve as a construction platform and prevent frost damage to the pavement will be used for all pavements designed to carry aircraft with a gross load of 100,000 pounds and greater.

The recommendations are broken down by gross weight of the design aircraft. There is some problem here in that the recommendations are based on the optimum for heavy traffic applications. If the number of equivalent design aircraft is low, it may be possible to reduce somewhat the level of load transfer needed at the specified joints. Specifically it may be possible to eliminate the diamond devices at the time of construction and to install them at a later date if there is evidence of distress at the joints. If there is no evidence of distress it may be possible to eliminate these devices. Actual data on performance of these systems are required before the specified traffic level at which the various joint systems should be used can be established.

Conclusions

The current practice of using keyways for load transfer in longitudinal joints is not satisfactory. Serious problems arise in both the performance

Table 8. Recommended Load Transfer Systems for Airport Pavements

Type Aircraft	Transverse Joint	Longitudinal Joints
Light aircraft with maximum gross weight of 30,000 pounds	Same as present (Ref. 4)	Butt joints, no load transfer required.
Medium: Aircraft with gross weight between 30,000 and 100,000 pounds with single or dual wheel gear	Same as present (Ref. 4), except with dowels at joints with heavy traffic, especially with larger aircraft	Butt joints, no load transfer - if stabilized subgrade used. If unstabilized subgrade used, support corners with dowels or diamond device as shown in Figure 22.
Medium to Heavy: Aircraft with gross weight between 100,000 and 350,000 pounds with dual wheel gear	Dowels in all transverse joints - size and space according to design aircraft gear load and configuration	Butt joints, with dowels or heavy tie bars at the three center joints as shown in Figure 23.
Heavy: Wide Body Aircraft (B747, DC-10, L-1011)	Dowel all joints Size and space according to design aircraft gear load and configuration	Butt joints with heavy tie bars at the three center joints and reinforce corners with diamond type load transfer device as shown in Figure 24.

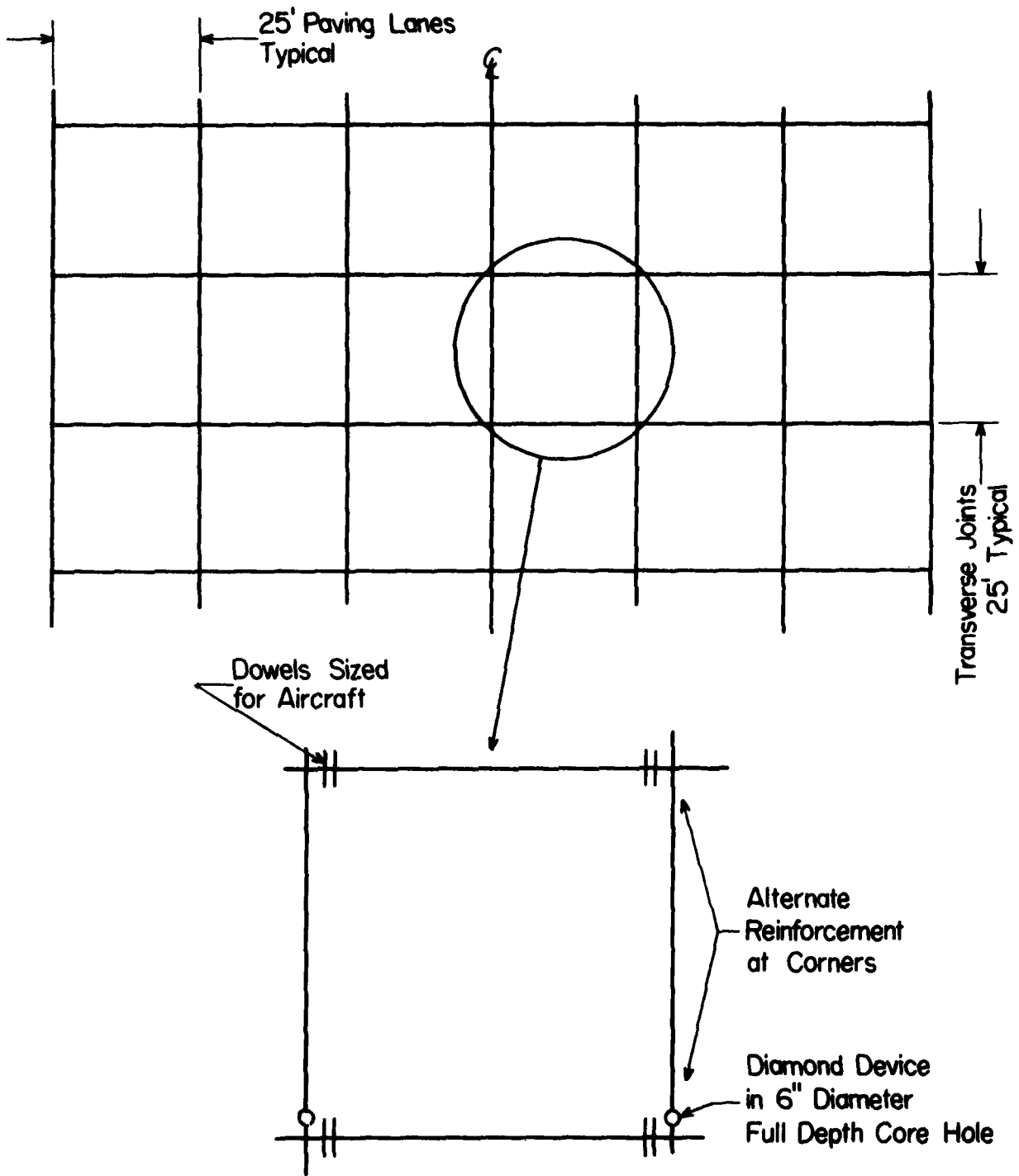

Figure 22. Recommended Load Transfer at Corners for Airport Pavements for Medium Aircraft.

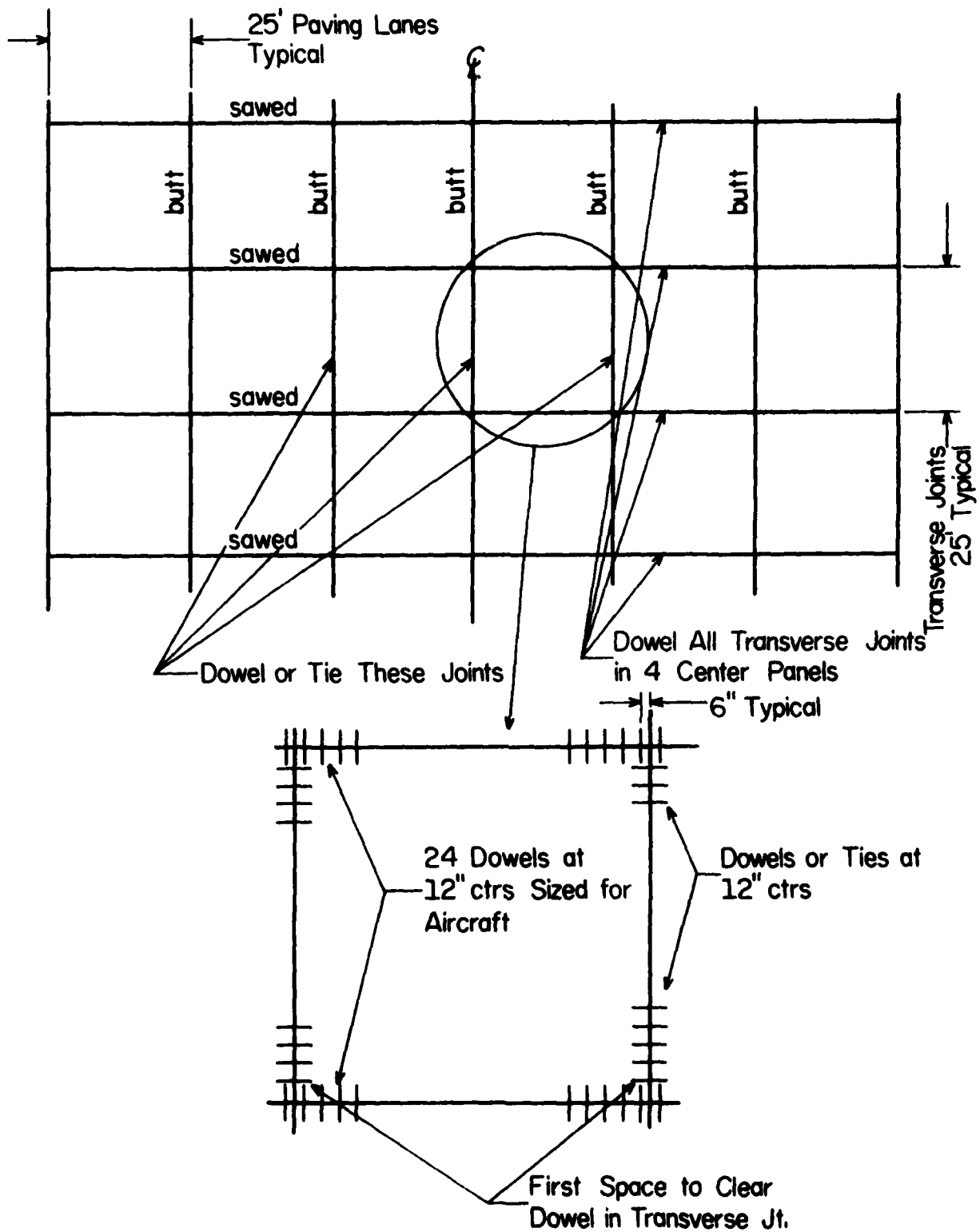

Figure 23. Recommended Load Transfer for Longitudinal and Transverse Joints for Airport Pavements to Serve Medium to Heavy Aircraft.

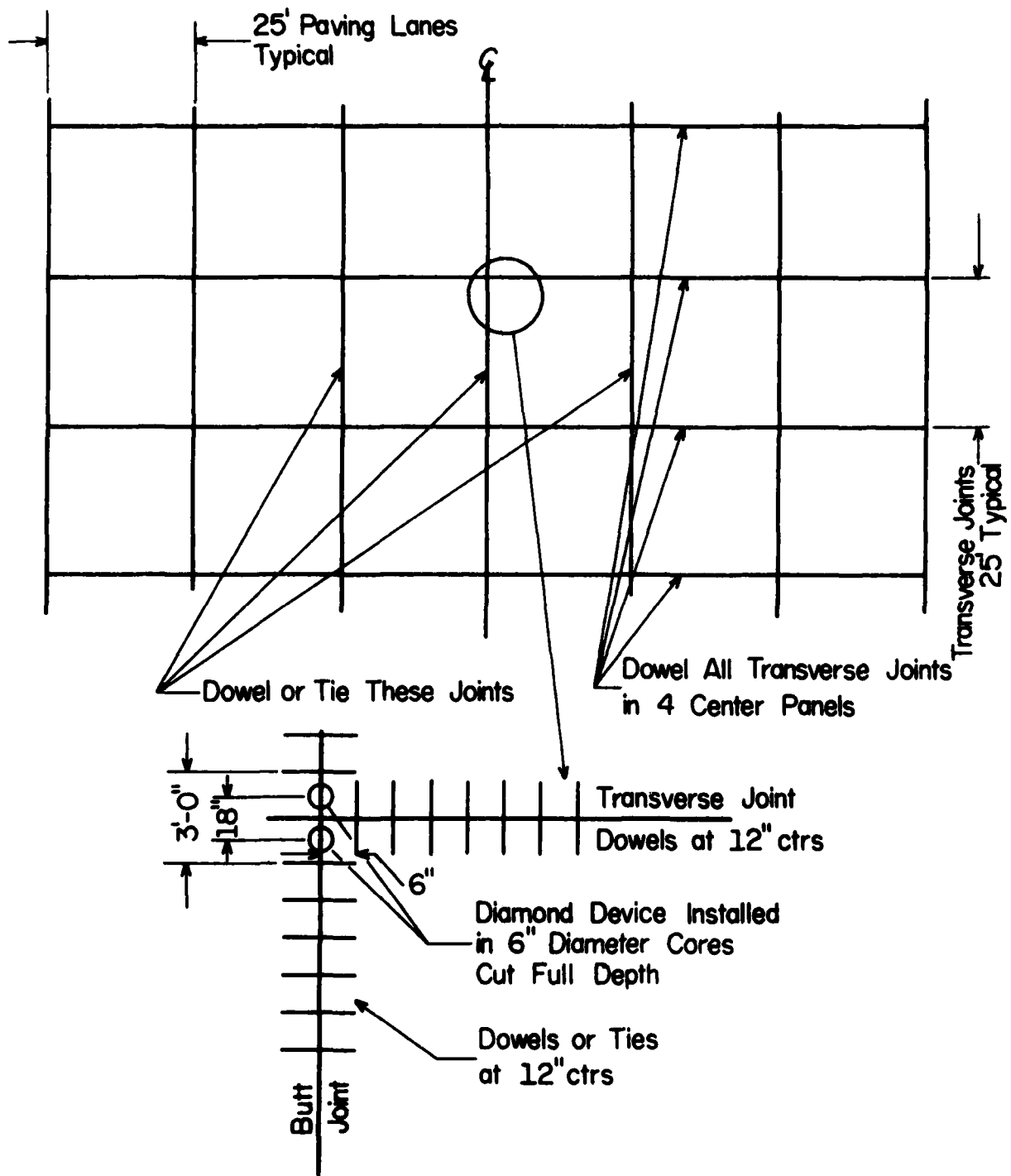

Figure 24. Recommended Load Transfer for Longitudinal and Transverse Joints for Airport Pavements to Serve Heavy Aircraft.

and construction of joints with keyways. The construction problems are most severe when constructing pavements using slip form pavers.

Not all pavements require load transfer systems in the longitudinal joints. For pavements intended primarily for aircraft with relatively light aircraft, load transfer is not required in either the longitudinal or transverse joints. Conversely, for pavements intended primarily for the very heavy aircraft, substantial load transfer is required in both the longitudinal and transverse joints. Those pavements intended to serve medium weight aircraft will require some level of load transfer somewhere between the extremes given above.

Probably the most cost effective load transfer system available to date is to use large diameter dowels in the transverse joints and large diameter dowels or tie bars in the longitudinal joints. Procedures have been developed to economically install either the tie bars or dowels in the longitudinal joints when using slip form pavers.

Specific problems encountered at the intersection of the longitudinal and transverse joints can be solved by installing the load transfer devices described in this report. Since these devices are installed in the hardened concrete, it is possible to evaluate the performance of pavements under existing traffic and then install the devices.

Finally, it was demonstrated in this report that stresses in the concrete are not the only cause of distress in PCC pavements. For pavements which serve the heavy aircraft such as the L-1011, DC-10 and 747, the maximum pavement deflection and concomitant maximum stress on the subgrade may be more critical to pavement performance than the maximum stress in the PCC slab. It was also shown that if maximum stress in the slab is the critical

parameter in the performance of the pavements, then added slab thickness is an effective way to achieve better performance. However, if maximum deflection and maximum stress on the subgrade are critical, then increasing slab thickness is not as cost effective as providing good load transfer across the joints.

## REFERENCES

1. Barenberg, E. J., and Smith, R. E., "Longitudinal Joint Systems in Slip-Formed Rigid Pavements; Volume I - Literature Survey and Field Inspection," Report No. FAA-RD-79-4, I, January 1979.
2. Tabatabaie, A. M., Barenberg, E. J., and Smith, R. E., "Longitudinal Joint Systems in Slip-Formed Rigid Pavements; Volume II - Analysis of Load Transfer Systems for Concrete Pavements," Report No. FAA-RD-79-4, II, November 1979.
3. Tabatabaie, A. M., Barenberg, E. J., "Longitudinal Joint Systems in Slip-Formed Rigid Pavements; Volume III - User's Manual," Report No. FAA-RD-79-4, III, November 1979.
4. "Airport Pavement Design and Evaluation," Federal Aviation Administration Advisory Circular AC-15015320-6C, December 1978.
5. Tabatabaie, A. M., and Barenberg, E. J., "Structural Analysis of Concrete Pavement Systems," Journal, ASCE, Vol. 106, No. TE5, September 1980.
6. Barenberg, E. J., and Arntzen, D. M., "Design of Airport Pavements as Affected by Load Transfer and Support Conditions," Proceedings 2nd International Conference on Concrete Pavement Design, Purdue University, April 1981.
7. Brandley, R. W., "Pavement Evaluation and Research Report - Runway 16L-34R, Runway 16R-34L, Taxiway A; Seattle-Tacoma International Airport," Unpublished Report, Consultant Brandley to SEA-TAC Airport Authority, December 1971.
8. Personal Observation by Author.
9. Arntzen, D. M., Airport Design Engineer, City of Chicago, Private Communication.
10. Rase, D. G., Richardson, Gordon and Associates, Consultant for Greater Pittsburgh Airport, Private Communication.
11. Brandley, R., Airport Consultant; Private Communication.
12. Ledbetter, W. B., Lytton, R. L., Britton, S. C., Sarver, H. L., Epps, J. A., Mahoney, J. P., and Rhodes, N. F., "Techniques for Rehabilitating Pavements without Overlays - A Systems Analysis; Vol. 1 - Analysis," FHWA-RD-78-108, September 1977.
13. Brandley, R., "Rehabilitation of Joints on San Diego Airport," Private Communication, November 1980.
14. Darter, M. I., Barenberg, E. J., Yrjanson, W. A., Ashley, G. R., and Okamoto, P. A., "Evaluation of Joint Repair Methods for Portland Cement Concrete Pavements," Draft of Interim Report for NCHRP 1-21, February 1981.

**LMED**

