

AD-A113 108

AIR FORCE OCCUPATIONAL MEASUREMENT CENTER RANDOLPH AFB TX F/6 5/9  
AVIONICS AEROSPACE GROUND EQUIPMENT (AGE) CAREER LADDER, AFSC 3--ETC(U)  
FEB 82

UNCLASSIFIED

NL

1 of 1

04 00

04 00

04 00

04 00

04 00

04 00

04 00

04 00

04 00

04 00

04 00

04 00

04 00

04 00

04 00

04 00

04 00

04 00

04 00

04 00

04 00

04 00

04 00

04 00

04 00

04 00

04 00

04 00

04 00

04 00

04 00

04 00

04 00

04 00

04 00

04 00

04 00

04 00

04 00

04 00

04 00

04 00

04 00

04 00

04 00

04 00

04 00

04 00

04 00

04 00

04 00

04 00

04 00

04 00

04 00

04 00

04 00

04 00

04 00

04 00

04 00

END

DATE

FILMED

4-82

DTIC

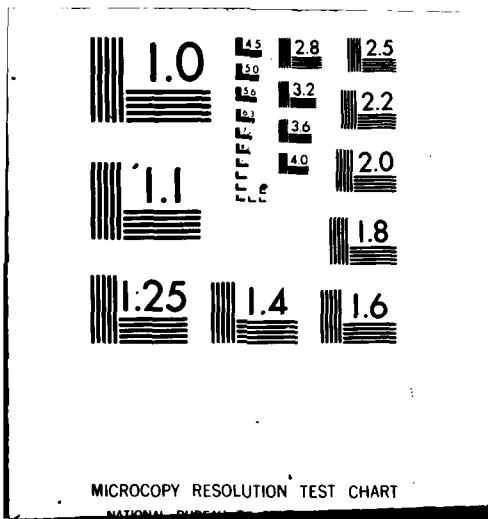

MICROCOPY RESOLUTION TEST CHART

NATIONAL BUREAU OF STANDARDS

12

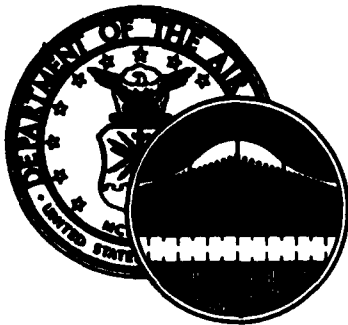

UNITED STATES AIR FORCE

AD A113188

# OCCUPATIONAL SURVEY REPORT



AVIONICS AEROSPACE GROUND EQUIPMENT (AGE)

CAREER LADDER

AFSC 326XOC/D

AFPT 90-326-428A

FEBRUARY 1982

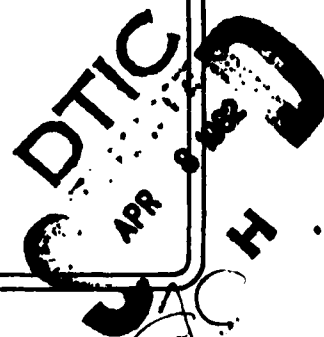

OCCUPATIONAL ANALYSIS PROGRAM  
USAF OCCUPATIONAL MEASUREMENT CENTER  
AIR TRAINING COMMAND  
RANDOLPH AFB, TEXAS 78150

APPROVED FOR PUBLIC RELEASE; DISTRIBUTION UNLIMITED

82 04 08 046

DTIC FILE COPY

DISTRIBUTION LIST FOR 326X0C/D OCCUPATIONAL SURVEY REPORT

	<u>OSR</u>	<u>JOB</u> <u>INV</u>	<u>ANL</u> <u>EXT</u>	<u>TNG</u> <u>EXT</u>
AFMPC/MPCRPQ	2			
DEFENSE TECHNICAL INFORMATION CENTER	1	1		
AFHRL/MODS	2	6	1m	1m
AFMEA/MEMD	1	1	1h	1
HQ USAF/MPPT	1	1		1
AFHRL/LRT	1	1	1m	
LTTT	5	2	2h	9
ARMY OCCUPATIONAL SURVEY BRANCH	1	1		
CCAF/AYX	1	1		
3507/DPUI	1	1		
AFMPC/MPCHS	1	1		
HQ AFISC/DAP	1	1		
HQ ATC/TTQ	2	1		1
NODAC	1	1		
HQ USMC/OMU	1	1		
LMDC/AN	1			
388 TFW/MAT	2	2		2
AFLMC/LGM	2	2		2
3785 FLDTG/TTFO	2	2		2
HQ ATC/DPAE	3	3		3
FTD 512 (ATC)	3	3		3
FTD 219 (ATC)	3	3		3
HQ MAC/DPAT	3	3		3
HQ PACAF/DPAT	3	3		3
HQ PACAF/DPAL	1	1		1
HQ SAC/DPAT	3	3		3
HQ SAC/LGMQ (ATCLO)	1	1		1
HQ TAC/DPAT	3	3		3
HQ TAC/DPLATC	1	1		1
HQ USAFE/DPAT	3	3		3
HQ USAFE/DPATC	1	1		1
HQ USAF FUNCTIONAL MANAGER	1	1		1

= microfiche only  
 = hard copy only.

TABLE OF CONTENTS

	<u>PAGE NUMBER</u>
PREFACE -----	iii
SUMMARY OF RESULTS -----	iv
INTRODUCTION -----	1
SURVEY METHODOLOGY -----	1
CAREER LADDER STRUCTURE -----	7
ANALYSIS OF DAFSC GROUPS -----	17
ANALYSIS OF EXPERIENCE (AFMS) GROUPS -----	23
ANALYSIS OF AFR 39-1 SPECIALTY DESCRIPTIONS -----	32
SPECIALTY TRAINING -----	32
MAJCOM COMPARISONS -----	33
ANALYSIS OF CONUS VERSUS OVERSEAS GROUPS -----	36
COMPARISON TO PREVIOUS SURVEY -----	38
WRITE-IN COMMENTS -----	38
CONCLUSIONS -----	39
APPENDIX A -----	40

Accession For	
NTIS GRA&I	<input checked="" type="checkbox"/>
DTIC TAB	<input type="checkbox"/>
Unannounced	<input type="checkbox"/>
Justification	
By _____	
Distribution/	
Availability Codes	
Dist	Avail and/or Special
A	



## PREFACE

This report presents the results of a detailed Air Force Occupational Survey of the Avionics Aerospace Ground Equipment (AGE) career ladder (326X0C/D). The report was prepared in response to a request by personnel at the Technical Training Center, Lowry AFB, Colorado and Headquarters, Air Training Command, Randolph AFB, Texas. Authority for conducting occupational surveys is contained in AFR 35-2. Computer outputs from which this report was produced are available for use by operating and training officials.

The survey instrument was developed by Mr Henry L. Dubois, Inventory Development Specialist. Mr Reginald G. Nolte and Captain Robert S. Collyer (Australian Army), Occupational Survey Analysts, analyzed the data and wrote the final report. This report has been reviewed and approved by Lieutenant Colonel Jimmy L. Mitchell, Chief, Airman Career Ladders Analysis Section, Occupational Analysis Branch, USAF Occupational Measurement Center, Randolph AFB, Texas 78150.

Copies of this report are distributed to air staff sections, major commands, and other interested training and management personnel. Additional copies may be obtained upon request to the USAF Occupational Measurement Center, attention of the Chief, Occupational Analysis Branch (OMY), Randolph AFB, Texas 78150.

PAUL T. RINGENBACH, Col, USAF  
Commander  
USAF Occupational Measurement  
Center

WALTER E. DRISKILL, Ph.D.  
Chief, Occupational Analysis Branch  
USAF Occupational Measurement  
Center

## SUMMARY OF RESULTS

1. Survey Coverage: Between the period March and July 1981, 260 USAF job inventory booklets were administered worldwide to members of AFS 326X0C and AFS 326X0D. Of the 201 respondents, 159 were from AFS 326X0C personnel (78 percent of assigned) and 42 were from AFS 326X0D (76 percent of assigned). All user major commands and paygrade groups were represented in the sample.
2. Job Structure: The job structure of AFS 326X0C/D was highly specialized. Overall, the incumbents formed clusters and job groups which were directly related to the avionics AGE associated with a specific weapons system. The vast majority of 326X0C/D personnel found their jobs quite interesting, although the A-7D Avionics AGE Shop Personnel cluster did not.
3. AFR 39-1 Specialty Descriptions: The jobs of the specialty specific functional areas adequately support the specialty descriptions as currently written.
4. Specialty Training: An analysis of 326X0C training was deferred pending refinement of the match of the Specialty Training Standard (STS) and tasks in the USAF Job Inventory. A Training Extract for the C-shred will be compiled as soon the revised matching is available. An analysis of 326X0D training was not performed since A-7D aircraft are being deleted from the active inventory and so few personnel are involved with the C-5 system.
5. MAJCOM Analysis: There were differences noted in the jobs performed by personnel across the MAJCOMs. These differences revolve around the unique weapons system found in each MAJCOM and the related shredouts.
6. Implications: For the most part, C- and D-shredout incumbents perform very specialized jobs directly related to the weapons system maintained. The findings of the survey strongly support the present career ladder structure and AFR 39-1 specialty descriptions.

OCCUPATIONAL SURVEY REPORT  
AVIONICS AEROSPACE GROUND EQUIPMENT (AGE) CAREER LADDER  
(AFSC 326X0C/D)

INTRODUCTION

This is a report of an occupational survey of the Avionics Aerospace Ground Equipment (AGE) career ladder (AFSC 326X0C/D) completed by the Occupational Analysis Branch, USAF Occupational Measurement Center in November 1981. The survey was requested by the Lowry Technical Training Center and Headquarters, Air Training Command to capture tasks related to the F/RF-4 aircraft which were not included in the previous 1975 survey because at that time the Category II Test Equipment for those aircraft was maintained by the user shops.

Background

Historically, this AFS evolved from a number of 32XXX AFSs related to the avionics area. Both the C and D shredouts were established 30 April 1976, with the 326X0C covering the F/RF-4 Aerospace Ground Equipment (AGE), and the 326X0D covering the A-7D AGE. On 30 October 1978, the C-5 was added to the D shredout, thus covering both A-7D and C-5 AGE. No further changes have occurred in the career ladder since October 1978.

The basic job of 326X0C/D personnel, as described by AFR 39-1, is to perform various activities related to identifying and isolating malfunctions of avionics aerospace ground equipment and to verify, calibrate, modify, and repair avionics aerospace ground equipment to include inspection of avionics aerospace ground equipment. Career ladder members receive formal training in the C-shredout at Lowry Air Force Base in a 16-week F/RF-4 Peculiar AGE basic course. D-shredout personnel are trained in A-7D Avionics Aerospace Ground Equipment at the Field Training Detachment (FTD), Davis-Monthan AFB, and C-5 AGE personnel are trained at the FTD, at Dover AFB.

SURVEY METHODOLOGY

Inventory Development

The data collection instrument for this occupational survey was USAF Job Inventory AFPT 90-326-428A. As a starting point, tasks from the 1975 inventory were reviewed, revised, and updated through detailed research of current career ladder publications and directives. This new tentative task list was then reviewed and validated by course personnel at LTTC and a number of subject matter specialists at Travis AFB CA; Nellis AFB NV; England AFB LA; Kelly AFB TX; and Bergstrom AFB TX. The resulting

APPROVED FOR PUBLIC RELEASE; DISTRIBUTION UNLIMITED

inventory contained 501 tasks grouped under 13 duty headings. Also included in the inventory was an extensive background section that asked for such information as:

- (A) Job Satisfaction
- (B) Level of Organization and POMO questions
- (C) Job Title and functional areas
- (D) Duty area and shop size
- (E) Supported aircraft
- (F) Career Field courses
- (G) Specialized Training
- (H) Equipment used

### Survey Administration

During the period March 1981 through July 1981, consolidated base personnel offices in operational units worldwide administered the job inventory to incumbents holding the 326X0C/D DAFSCs. These personnel were selected from a computer generated mailing list which was obtained from personnel data tapes maintained by the Air Force Human Resources Laboratory (AFHRL).

Each respondent who completed a job inventory first completed an identification and biographical information section and then checked all tasks which were performed in his or her present job. Those tasks that were checked were then rated on a nine-point scale showing the relative amount of time spent on that task as compared to all other tasks checked. The ratings ranged from one (very small amount of time spent) to nine (very large amount of time spent), with a rating of five representing an average amount of time spent in performing a task).

To determine the relative amount of time spent on each task checked by a respondent, all of the incumbent's ratings are assumed to account for 100 percent of the time spent on the job. These ratings are totaled and each task rating is then divided by the total number of task responses. The resulting quotient is then multiplied by 100. This procedure provides a basis for comparing all tasks in terms of both percent members performing and relative percent time spent.

### Data Processing

Once job inventories are returned from the field, they are prepared so that task responses and background information can be optically scanned. Other biographical information (such as name, base, AUTOVON extension) are keypunched onto disks and entered directly into a UNIVAC 1108 computer. Once both sets of data are entered into the computer, the tasks, background, and biographical information are merged to form a complete case record for each respondent. Computer generated programs using Comprehensive Occupational Data Analysis Programs (CODAP) techniques are then applied to the data.

### Task Factor Administration

In addition to completing the job inventory, selected senior 326X0C/D incumbents were also asked to complete a second booklet for training emphasis (see Table 4 for command representation of raters). The small number of senior technicians (7-skill level) for each shredout precludes collecting task difficulty (TD) data. To have collected complete data would have required every 7-skill level individual to fill out a task inventory, a TD booklet, and a Training Emphasis (TE) booklet, which would represent an inordinate amount of time and effort. Since training emphasis data has not previously been collected for this specialty, we chose to collect only TE ratings for this study.

Training Emphasis. A group of senior NCOs receiving training emphasis booklets were asked to rate all of the tasks on a ten-point scale which ranged from no training required to extremely heavy training required. Training emphasis yields a rating of tasks which indicates where the emphasis should be placed on structured training for first-term personnel. Structured training is defined as training provided at resident technical schools, field training detachments (FTD), mobile training teams (MTT), formal OJT, or any other organized training method.

The interrater reliability (as assessed through the components of variance of standard group means) for C-shredout raters was .94, which indicated a very high degree of agreement among the raters as to which tasks required some form of structured training and which did not. Tasks which were rated highest in training emphasis had ratings of 3.40 and above, while the average rating was 1.93. Those tasks with a training emphasis rating of .46 and below could be considered to require very little emphasis in training.

D-shredout interrater reliability was .89. Tasks which were rated highest in training emphasis had ratings of 4.97 and above, while the average rating was 2.91. Those tasks with a training emphasis rating of .85 and below could be considered to require very little emphasis in training.

When used in conjunction with other factors, such as percent members performing, the training emphasis ratings can provide an insight into training requirements. This information may help validate the lengthening or shortening of specific units in various training programs.

### Survey Sample

Incumbents were selected to participate in this survey so as to ensure an accurate representation across all MAJCOM and paygrade groups. Tables 1 and 2 list the distribution of assigned and sampled personnel by major command and paygrade groups, respectively. Table 3 reflects the distribution of the survey sample in terms of months Total Active Federal Military Service (TAFMS). As demonstrated by these tables, the overall sample was representative of the career ladder population as a whole.

**TABLE 1**  
**COMMAND REPRESENTATION OF SURVEY SAMPLE**

<u>COMMAND</u>	<u>C-SHRED</u>		<u>D-SHRED</u>	
	<u>PERCENT OF ASSIGNED</u>	<u>PERCENT OF SAMPLE</u>	<u>PERCENT OF ASSIGNED</u>	<u>PERCENT OF SAMPLE</u>
TAC	42	39	22	31
USAFE	28	30	0	0
PACAF	16	16	0	0
ATC	9	12	11	12
MAC	0	0	60	57
AAC	2	3	0	0
OTHER	<u>3</u>	<u>0</u>	<u>7</u>	<u>0</u>
	100	100	100	100

**ASSIGNED:**

C-SHRED - 205  
D-SHRED - 55  
TOTAL - 260\*

**SURVEYED:**

C-SHRED - 159 (78%)  
D-SHRED - 42 (76%)  
TOTAL - 201 (77%)

\*AUTHORIZED STRENGTH AS OF 31 JAN 1981

TABLE 2  
PAYGRADE REPRESENTATION OF SURVEY SAMPLE

<u>PAYGRADE</u>	<u>C-SHRED</u>		<u>D-SHRED</u>	
	<u>PERCENT OF ASSIGNED</u>	<u>PERCENT OF SAMPLE</u>	<u>PERCENT OF ASSIGNED</u>	<u>PERCENT OF SAMPLE</u>
AIRMAN	23	20	29	31
E-4	22	21	18	14
E-5	31	37	33	36
E-6	14	13	13	17
E-7	<u>10</u>	<u>9</u>	<u>7</u>	<u>2</u>
	100	100	100	100

TABLE 3  
TAFMS DISTRIBUTION OF SURVEY SAMPLE

	<u>MONTHS TOTAL ACTIVE FEDERAL MILITARY SERVICE</u>					
	<u>1-48</u>	<u>49-96</u>	<u>97-144</u>	<u>145-192</u>	<u>193-240</u>	<u>241+</u>
NUMBER IN AFS 326XOC SAMPLE	48	46	26	19	13	7
PERCENT OF AFS 326XOC SAMPLE	30%	29%	16%	13%	8%	4%
NUMBER IN AFS 326XOD SAMPLE	15	12	7	5	3	0
PERCENT OF AFS 326XOD SAMPLE	36%	29%	16%	12%	7%	0

TABLE 4

## COMMAND REPRESENTATION OF 326XOC/D TRAINING EMPHASIS RATERS

<u>COMMAND</u>	<u>C-SHRED</u>		<u>D-SHRED</u>	
	<u>PERCENT OF ASSIGNED</u>	<u>PERCENT OF TE RATERS</u>	<u>PERCENT OF ASSIGNED</u>	<u>PERCENT OF TE RATERS</u>
TAC	42	35	22	29
USAFE	28	47	0	0
PACAF	16	6	0	0
ATC	9	9	11	14
MAC	0	0	60	57
AAC	2	3	0	0
OTHER	<u>3</u>	<u>0</u>	<u>7</u>	<u>0</u>
	100	100	100	100

## CAREER LADDER STRUCTURE

A key aspect of the Occupational Analysis Program is to examine the job structure of each specialty on the basis of what people are actually doing in the field, rather than on the basis of what official career ladder documents say they are doing. This analysis of actual job structure is made possible by the use of the Comprehensive Occupational Data Analysis Programs (CODAP). By using CODAP, jobs are identified on the basis of similarity in tasks performed and the relative time spent performing those tasks.

The specialty structure analysis process consists of determining the functional job structure of career ladder personnel in terms of job types, clusters, and independent job types. A job type is a group of individuals who perform many of the same tasks and also spend similar amounts of time performing them. When there is a substantial degree of similarity between different job types, they are grouped together and labeled as clusters. Finally, there are often cases of specialized job types that are too dissimilar to be grouped into any cluster. These unique groups are labeled independent job types.

### Specialty Overview

The job structure of the Avionics Aerospace Ground Equipment career ladder was determined by performing a job type analysis of the 201 survey respondents. Based on similarity of tasks performed and the amount of time spent in performing each task, the jobs performed by the 326X0C/D respondents are listed below and illustrated in Figure 1. (Each job group is identified with a group identification number to cross reference the groups to computer printouts included in the statistical summary package provided to selected users. These identification numbers are shown as GRP numbers for each type of job.)

- I. SUPERVISORY-INSTRUCTOR PERSONNEL (GRP004, N=40)
  - a. Supervisory Personnel (GRP005, N=31)
  - b. Instructor Personnel (GPR013, N=9)
  
- II. F-4/RF-4 AVIONICS AGE SHOP PERSONNEL (GRP018, N=110)
  - a. Avionics AGE Shop Chiefs (GRP047, N=47)
  - b. Component Repair Personnel (GRP049, N=57)
  
- III. COMPONENT REPAIR TRAINEES (GRP028, N=14)
  
- IV. A-7D AVIONICS AGE SHOP PERSONNEL (GRP072, N=14)
  
- V. C-5 AVIONICS AGE SHOP PERSONNEL (GRP020, N=20)

FIGURE 1

AVIONICS AEROSPACE GROUND EQUIPMENT CAREER LADDER STRUCTURE

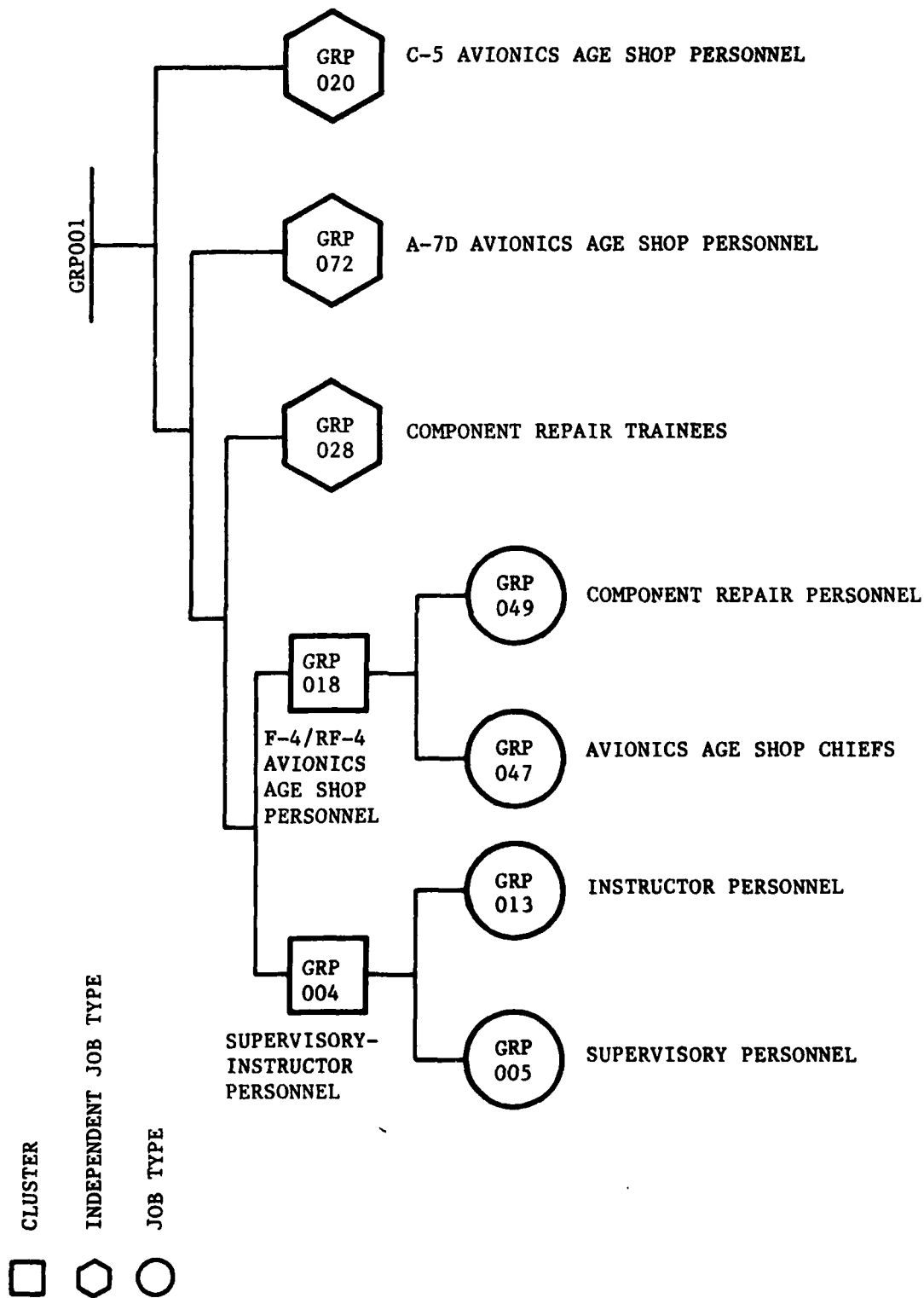

The respondents forming these clusters and job types accounted for 98 percent of the total survey sample. The remaining two percent of the sample consisted of respondents who did not group with any of the job types or clusters described above.

In general, the 326X0C/D career ladder respondents fell into clusters and job types which reflected the type of aircraft peculiar aerospace ground equipment which they service. This finding should not be surprising since C-shred personnel use F/RF-4 peculiar AGE and D-shred personnel use A-7D or C-5 avionics AGE. A review of test equipment used shows no overlap between A-7, C-5, and F/RF-4 Avionics AGE personnel except for GRP028 which is a related F-4/RF-4 group (see Table 8).

Within the F-4/RF-4 Avionics AGE Shop Personnel Cluster, there were small job types which indicated grouping by aircraft models such as RF-4C, F-4C, F-4D, F-4E, F-4F and F-4G; however, these small breakouts were not exclusive or distinct enough by model to permit job typing to any single aircraft model.

### Job Group Descriptions

The following paragraphs contain brief descriptions of the clusters, their respective job types, and the independent job types identified through the specialty structure analysis. In addition, Table 5 provides selected background information and Table 6 lists job satisfaction data for the job groups. Also included at the end of this report is Appendix A, which contains representative tasks for each of the clusters, job types and independent job types.

I. SUPERVISORY-INSTRUCTOR PERSONNEL (GRP004, N=40). These incumbents represented the second largest cluster identified within the 326X0C/D career ladder, accounting for 20 percent of the sample. These 40 incumbents performed a wide range of tasks related to supervision and training which took up 85 percent of their job time. Seventy-five percent of these respondents hold a 7-skill level. This group is the most senior group, composed mainly of E-5 and E-6 personnel. They have an average of 148 months TAFMS. Overall, these individuals reported performing an average of 44 tasks, the lowest number in the survey sample. Their job typically involves such tasks as:

- demonstrate how to locate technical information
- write correspondence
- plan work assignments
- administer tests
- inventory equipment, tools, or supplies
- interpret policies, directives, or procedures for subordinates
- counsel trainees on training progress
- analyze workload requirements
- assign personnel to duty positions
- establish performance standards

Job satisfaction and other morale factors for this cluster are relatively high. There are two job types within the cluster. The larger group consists of 31 personnel who are involved primarily in supervisory tasks. These respondents are very senior in grade (typically E-6), supervise an average of 4 persons, and are assigned to a number of different commands. The smaller job type within the cluster consists of nine respondents who are all assigned to ATC. Fifty-six percent are assigned to Resident Technical Training Centers, while the balance are in Field Training Detachments (FTD) or wings and squadrons. These incumbents are somewhat more junior (typically E-4 and E-5), supervise relatively few personnel, and perform roughly half of the tasks that the larger group perform (26 average number of tasks versus 50). All nine incumbents hold the T prefix.

II. F-4/RF-4 AVIONICS AGE SHOP PERSONNEL (GRP018, N=110). This cluster is the largest in the survey sample and, as a group, performs the highest average number of tasks (137). The cluster consists of 110 respondents, representing 54 percent of the sample. Nearly all of the personnel in the cluster indicate that they are assigned to Component Repair Squadrons and work in Avionics AGE shops. All these incumbents work on avionics AGE associated with the F-4/RF-4 weapons system. Typical tasks include:

- calibrate torque wrenches
- remove or replace printed circuit boards
- troubleshoot AN/ASM-442 air data computer test sets
- make entries on Maintenance Data Collection Record (AFTO Form 349)
- make entries on Reparable Item Processing Tag (AFTO Form 349)
- service torque wrenches
- remove or replace transistors
- troubleshoot AN/APM-307 interceptor control system test sets
- make entries on PME Certification Label (AFTO Form 108)
- remove or replace resistors

Personnel have an average 81 months TAFMS. Twenty-nine percent are in their first enlistment and 53 percent of the cluster incumbents are assigned to bases overseas. Morale indicators for this large group are quite good. Within this large cluster, two distinct job groups appear. The first job type identified within this cluster was Avionics AGE Shop Chiefs (GRP047, N=47). These members perform an average of 171 tasks, have 107 months TAFMS, and supervise three persons on the average. Eleven percent are in their first enlistment. The second job type, Component Repair Personnel (GRP049, N=57) perform an average of 113 tasks and have an average of 58 months TAFMS. Forty-seven percent of these incumbents are in their first enlistment. The jobs these two groups perform are extremely similar. The differentiation is in experience level, number of tasks performed, and grade level.

III. COMPONENT REPAIR TRAINEES (GRP028, N=14). This small independent job group is an extension of the previous cluster. The job they perform is essentially identical; however, they perform relatively fewer tasks (47 versus 137 for the larger cluster). Seventy-nine percent of these incumbents are in their first enlistment and none hold the 7-skill level. The

fairly limited tasks they perform tend to be the simpler type, such as remove or replace lamps, switches, relays, capacitors, wires, and other similar trainee functions. They have very good morale indicators, however, and 43 percent indicate that they intend to reenlist.

**IV. A-7D AVIONICS AGE SHOP PERSONNEL (GRP072, N=14).** As the title suggests, the 14 incumbents in this small cluster are D-shred personnel who work exclusively on Avionics AGE associated with the A-7D weapons system. The majority of the members are assigned to TAC; however, three incumbents are T-prefix individuals assigned to FTDs in ATC. All TAC members are assigned to Component Repair Squadrons. Incumbents average 92 months TAFMS and perform an average of 130 tasks, second highest in the career ladder. Typical tasks performed are:

- align 500RM tally punched tape readers
- perform self-tests of AN/AVM-11A HUD Test Sets
- remove or replace printed circuit boards
- perform fault isolation of 500RM tally punched tape readers
- align AN/APM-336 video servo test sets
- clean tape heads
- perform fault isolation of AN/AVM-11A HUD test sets
- remove or replace capstands on magnetic or punch tape units
- remove or replace relays
- perform minimum performance tests of AN/APM-336 video servo test sets

Twenty-two percent of the members of this group are 7-skill level incumbents. Morale indicators for this group are rather low when compared to the other groups (See Table 6).

**V. C-5 AVIONICS AGE SHOP PERSONNEL (GRP020, N=20).** The incumbents within this cluster are all D-shred personnel who work exclusively on avionics AGE associated with the C-5 weapons system. These members average 55 months TAFMS, are fairly junior in grade on the average, and 55 percent are in their first enlistment. All incumbents are assigned to MAC. They perform, on the average, 114 tasks, which include such tasks as:

- troubleshoot 20660200-603A IDNE portable programmers
- calibrate 20660200-603A IDNE portable programmers
- calibrate 2551F0200-4 malfunction detecting and recording (MADAR) system test sets
- perform self-tests of 2551B0200-4 MADAR system test sets
- perform self-tests of MR1505 test set adapters other than VF2215B2
- perform self-tests of MR1505 test sets
- make entries on Reparable Item Processing Tag (AFTO Form 350)
- calibrate 2066001-605A inertial doppler navigation equipment (IDNE) test sets
- calibrate MR1505 test sets
- calibrate MR1505 test set adapters other than VG2215B2

Twenty-five percent of the members of this cluster hold the 7-skill level and all incumbents are assigned in the CONUS. Morale indicators for the cluster are quite good and 65 percent indicate an intention to reenlist.

#### Structure Summary

Overall, the incumbents within this career field formed clusters and job groups which were directly related to the avionics AGE associated with a specific weapons system. The number of incumbents assigned to the C-shred and D-shred was also directly related to the number of each weapon system in the Air Force inventory. The career field is highly specialized and, because of the small number of members assigned, presents training problems, particularly in the D-shred which currently receives the bulk of their training from Field Training Detachments (FTD). Other than the Supervisory-Instructor Personnel cluster, personnel in all the other clusters and job groups spent approximately three-fourths of their job time on tasks related to the specific weapons system to which they are assigned.

An examination of job satisfaction information reveals that, while the vast majority of personnel in the 326X0C/D career ladder found their job quite interesting, the A-7D Avionics AGE Shop Personnel cluster did not. This same cluster also had a fairly low perception as to the use of their talents. C-5 Avionics AGE Shop Personnel had a very high (65 percent) reenlistment intention when compared to all other groups in the career field.

TABLE 5  
BACKGROUND DATA FOR FUNCTIONAL JOB GROUPS

	SUPERVISORY- INSTRUCTOR PERSONNEL		F-4/RF-4 AVIONICS AGE SHOP PERSONNEL		COMPONENT REPAIR TRAINEES		A-7D AVIONICS AGE SHOP PERSONNEL		C-5 AVIONICS AGE SHOP PERSONNEL	
NUMBER IN GROUP:	40		110		14		14		20	
PERCENT OF SAMPLE:	20%		54%		7%		7%		10%	
PERCENT LOCATED OVERSEAS:	30%		53%		36%		-		-	

DAFSC DISTRIBUTION

32630C	5%	9%	36%	-	-	-	-	-	-	-
32650C	20%	72%	64%	-	-	-	-	-	-	-
32670C	58%	19%	-	-	-	-	-	-	-	-
32630D	-	-	-	7%	-	-	7%	-	25%	-
32650D	-	-	-	-	-	-	71%	-	50%	-
32670D	17%	-	-	-	-	-	22%	-	25%	-

AVERAGE MONTHS IN CAREER FIELD:  
AVERAGE MONTHS IN SERVICE (TAFMS):  
PERCENT IN FIRST ENLISTMENT:

57	46	24	61	48
148	81	32	92	55
13%	29%	79%	21%	55%

AVERAGE NUMBER OF MEMBERS SUPERVISED:  
AVERAGE NUMBER OF TASKS PERFORMED:

3	2	*	1	1
44	137	47	130	114

\*DEMOTES LESS THAN ONE PERCENT

TABLE 6

JOB SATISFACTION DATA FOR FUNCTIONAL JOB GROUPS  
(PERCENT MEMBERS RESPONDING)

	SUPERVISORY- INSTRUCTOR PERSONNEL		F-4/RF-4 AVIONICS AGE SHOP PERSONNEL		COMPONENT REPAIR TRAINEES		A-7D AVIONICS AGE SHOP PERSONNEL		C-5 AVIONICS AGE SHOP PERSONNEL	
<u>I FIND MY JOB:</u>										
DULL	13	9	7	29	5					
SO-SO	5	16	14	21	10					
INTERESTING	82	75	79	50	85					
<u>MY JOB UTILIZES MY TALENTS:</u>										
LITTLE OR NOT AT ALL	18	7	21	43	10					
FAIRLY WELL OR BETTER	82	93	79	57	90					
<u>MY JOB UTILIZES MY TRAINING:</u>										
LITTLE OR NOT AT ALL	20	14	14	14	10					
FAIRLY WELL OR BETTER	80	86	86	86	90					
<u>I PLAN TO REENLIST:</u>										
NO OR PROBABLY NO	30	47	57	57	35					
YES OR PROBABLY YES	42	47	43	43	65					
PLAN TO RETIRE (COMPLETED 20 YEARS OF SERVICE)	28	6	*	*	*					

\*DEMOTES LESS THAN ONE PERCENT

**TABLE 7**

**DAFSC 326XOC/D DISTRIBUTION ACROSS JOB GROUPS  
(NUMBER RESPONDING)**

<b>JOB GROUPS</b>	<b>DAFSC 32630C (N=17)</b>	<b>DAFSC 32650C (N=96)</b>	<b>DAFSC 32670C (N=44)</b>	<b>DAFSC 32630D (N=6)</b>	<b>DAFSC 32650D (N=20)</b>	<b>DAFSC 32670D (N=15)</b>
<b>SUPERVISORY-INSTRUCTOR PERSONNEL</b>	2	8	23	-	-	7
<b>F-4/RF-4 AVIONICS AGE SHOP PERSONNEL</b>	10	79	21	-	-	-
<b>COMPONENT REPAIR TRAINERS</b>	5	9	-	-	-	-
<b>A-7D AVIONICS AGE SHOP PERSONNEL</b>	-	-	-	1	10	3
<b>C-5 AVIONICS AGE SHOP PERSONNEL</b>	-	-	-	5	10	5

TABLE 8

TEN MOST COMMONLY USED TEST EQUIPMENT ITEMS BY  
F-4/RF-4, A7-D, AND C-5 GROUPS

## GRP018 F-4/RF4 AVIONICS AGE SHOP PERSONNEL

AM/ASH-442 AIR DATA COMPUTER TEST SETS  
 AM/ASH-194 INERTIAL NAVIGATION ELECTRONIC TEST  
 AM/AFM-307 INTERCEPTOR CONTROL SYSTEM TEST SETS  
 AM/AMH-20 FIRE CONTROL SYSTEM TEST SETS  
 AM/ASH-247 GYRO BIAS TEST SETS  
 AM/ASH-246 INERTIAL NAVIGATION TEST SETS  
 AM/ASH-208 INERTIAL PLATFORM TEST SETS  
 CN808A VOLTAGE REGULATORS  
 TS2505 ASH-270 AIR DATA COMPUTER TEST SETS  
 TS2358 AMH-270A ALTITUDE ENCODER TEST SETS

## GRP028 COMPONENT REPAIR TRAINERS (F-4/RF-4)

AM/ASH-442 AIR DATA COMPUTER TEST SETS  
 AM/ASH-194 INERTIAL NAVIGATION ELECTRONIC TEST  
 AM/AFM-307 INTERCEPTOR CONTROL SYSTEM TEST SETS  
 AM/AMH-20 FIRE CONTROL SYSTEM TEST SETS  
 AM/ASH-247 GYRO BIAS TEST SETS  
 AM/ASH-246 INERTIAL NAVIGATION TEST SETS  
 AM/ASH-208 INERTIAL PLATFORM TEST SETS  
 CN808A VOLTAGE REGULATORS  
 AM/AJM-17 COMPUTER TEST SETS  
 53E150525-1 MAVERICK INTERFACE TEST SETS

## GRP072 A-7D AVIONICS AGE SHOP PERSONNEL

500 RM TALLY PUNCHED TAPE READERS  
 AM/AVH-11A HUD TEST SETS  
 AM/ASH-403 MWDC TEST SETS  
 AM/AMH-55 ASCU TEST SETS  
 AM/ASH-375 IMS TEST SETS  
 AM/AFH-336 VIDEO SERVO TEST SETS  
 AM/AFH-335 ANTENNA RECEIVER TEST SETS  
 AC LINE VOLTAGE REGULATORS  
 AM/AFM-331 RADAR MODULE TEST SETS  
 AM/AJM-32 ADC TEST SETS

## GRP020 C-5 AVIONICS AGE SHOP PERSONNEL

20660200-603A IDME PORTABLE PROGRAMMERS  
 2551F0200-4 MALFUNCTIONS DETECTING AND RECORDING (MADAR)  
 SYSTEM TEST SETS  
 2066C001-605A INTERNAL DOPPLER NAVIGATION EQUIPMENT (IDME)  
 TEST SETS  
 MR 1505 TEST SETS  
 MR 1505 TEST SET ADAPTERS OTHER THAN UG2215B2  
 20662000-602A AGE CARD TEST SETS  
 95-001-04 CENTRAL AIR DATA COMPUTER (CADC) TEST SETS  
 951-0044-002 GO-AROUND ALTITUDE SYSTEM (GASS) TEST SETS  
 3608-20000 MULTIMODE RADAR TEST SETS  
 UG2215B2 ELECTRONIC SYSTEMS ADAPTERS

## ANALYSIS OF DAFSC GROUPS

The high degree of specialization reflected by the C- and D-shredout personnel in the job structure is exhibited by the DAFSC distribution across job groups shown in Table 7.

In addition to identifying the job structure of the 326X0C/D career ladder, the 3-, 5-, and 7-skill level groups within the survey sample were also examined. This analysis revealed similarities and differences between these groups in terms of time they spent on various duties. Information from this analysis may also be useful in determining the accuracy of career ladder documents, such as the AFR 39-1 Specialty Descriptions and the Specialty Training Standard (STS).

Overall, as is common in many specialties, the jobs of 3- and 5-skill level personnel are primarily technical in nature. Consequently, members of the 3- and 5-skill level C-shred groups reported spending an average of 82 percent and 75 percent of their time, respectively, on technical functions. D-shred groups spent an average of 85 percent of their time at the 3- and 5-skill levels on technical tasks.

Table 9 portrays the technical areas where C-shred and D-shred incumbents spend the majority of their job time. As would be expected, the technical areas relate directly to the weapon systems which they are assigned to.

Tables 10 through 13 provide a list of differentiating tasks between the skill groups in each of the shreds. The primary difference between the 3- and 5-skill level C-shred personnel appear to be that the 5-skill level personnel are more involved in performing the maintenance of F-4/RF-4 test sets and adapters and certain supervisory tasks. D-shred 3- and 5-skill level differences show the 5-skill level personnel to be more involved in repairing and servicing test sets and stations, which is a common duty area for both of the shredouts.

In comparison, those respondents holding a 7-skill level reported spending much of their time on supervisory and administrative functions. These incumbents spent an average of over 63 percent of their time on tasks related to these duties (32670Cs, 66 percent and 32670Ds, 63 percent). Tables 11 and 14 portray representative tasks performed by 7-skill level personnel of each shredout. Tables 16 and 18 show differentiating tasks between 5- and 7-skill level personnel of each shredout. As demonstrated by these tables, individuals holding the 7-skill level are involved in many activities related to personnel management, evaluation, training, and general administration.

### Summary

Overall, the jobs of the 3- and 5-skill personnel were very similar. Both groups perform a wide range of technical tasks. At the 7-skill level, respondents spend the majority of their time on supervisory tasks and are less involved in technical tasks.

TABLE 9

## RELATIVE PERCENTAGE OF TIME SPENT ON DUTIES BY DAFSC GROUPS

DUTIES	32630C PERSONNEL (N=16)	32650C PERSONNEL (N=98)	32670C PERSONNEL (N=45)	32630D PERSONNEL (N=7)	32650D PERSONNEL (N=20)	32670D PERSONNEL (N=15)
A ORGANIZING AND PLANNING	1	2	12	1	1	7
B DIRECTING AND IMPLEMENTING	1	4	15	1	2	15
C INSPECTING AND EVALUATING	1	3	12	-	2	11
D TRAINING	4	4	11	-	2	13
E PERFORMING ADMINISTRATIVE OR SUPPLY FUNCTIONS	11	12	16	13	8	17
F MAINTAINING A-7D SEMIAUTOMATIC TEST SETS	-	-	-	2	9	3
G MAINTAINING A-7D MANUAL TEST SETS	-	-	-	5	16	5
H MAINTAINING C-5A SELF-CONTAINED SEMIAUTO- MATIC TEST SETS AND ADAPTERS	-	-	-	22	9	5
I MAINTAINING C-5A MANUAL TEST SETS AND ADAPTERS	-	-	-	37	18	8
J MAINTAINING F-4/RF-4 SEMIAUTOMATIC TEST SETS AND ADAPTERS	11	8	4	-	-	-
K MAINTAINING F-4/RF-4 MANUAL TEST SETS AND ADAPTERS	22	29	14	-	-	-
L REPAIRING AND SERVICING TEST SETS AND STATIONS	44	34	13	11	30	14
M PERFORMING AVIONICS AGE GENERAL SHOP MAINTENANCE	5	4	3	8	3	2

TABLE 10

**TASKS WHICH BEST DIFFERENTIATE DAFSC 32630C AND 32650C PERSONNEL  
(PERCENT MEMBERS PERFORMING)**

<u>TASKS</u>	<u>DAFSC 32630C (N=16)</u>	<u>DAFSC 32650C (N=98)</u>	<u>DIFFERENCE</u>
D70 DEMONSTRATE HOW TO LOCATE TECHNICAL INFORMATION	6	59	-53
B33 SUPERVISE APPRENTICE AVIONICS AGE SPECIALISTS (AFSC 32630C)	0	47	-47
E100 MAKE ENTRIES ON ISSUE/TURN IN REQUEST FORMS (AF FORM 2005)	37	80	-43
K329 CALIBRATE JT20 FIELD LEVEL TEST SETS	0	42	-42
B35 SUPERVISE AVIONICS AGE SPECIALISTS (AFSC 32650C)	0	40	-40
E99 MAKE ENTRIES ON EQUIPMENT CONDITION TAG OR LABEL FORMS (DD FORMS 1574 THROUGH 1577-3)	31	70	-39
D66 CONDUCT OJT	0	38	-38
A15 PLAN WORK ASSIGNMENTS	0	35	-35
C59 PREPARE APRs	0	35	-35
E114 MAKE ENTRIES ON TECHNICAL ORDER SYSTEM PUBLICATION IMPROVEMENT REPORT (AFTO FORM 22)	19	53	-34
E86 APPLY NO CALIBRATION REQUIRED LABELS (AFTO FORM 256)	31	65	-34
B21 DIRECT AVIONICS AEROSPACE GROUND EQUIPMENT (AGE) SHOP FUNCTIONS	0	34	-34
B30 INTERPRET POLICIES, DIRECTIVES, OR PROCEDURES FOR SUBORDINATES	0	34	-34
K398 TROUBLESHOOT JT20 FIELD LEVEL TEST SETS	6	39	-33
K300 CALIBRATE AN/ASH-159 COMPUTER INDICATOR TEST SETS	25	57	-32
E115 MAKE ENTRIES ON TEMPORARY ISSUE RECEIPT (AF FORM 1297)	38	69	-31
B20 COUNSEL PERSONNEL ON PERSONAL OR MILITARY RELATED PROBLEMS	6	37	-31
E104 MAKE ENTRIES ON NON-NSN REQUISITION (MANUAL) (DD FORM 1348-6)	6	37	-31
K399 TROUBLESHOOT J202ASM85 DISTRIBUTION BOXES	6	37	-31
L465 REMOVE OR REPLACE LIGHT SENSORS	0	31	-31

TABLE 11

TASKS WHICH BEST DIFFERENTIATE DAFSC 32650C AND 32670C PERSONNEL  
(PERCENT MEMBERS PERFORMING)

TASKS	DAFSC 32650C (N=98)	DAFSC 32670C (N=45)	DIFFERENCE
L471 REMOVE OR REPLACE POWER SUPPLIES	88	42	+46
L476 REMOVE OR REPLACE RESISTORS	90	44	+46
L463 REMOVE OR REPLACE LAMPS	87	42	+45
L482 REMOVE OR REPLACE SWITCHES	87	42	+45
M492 CLEAN EXTERIORS OF SHOP EQUIPMENT	82	38	+44
L488 REMOVE OR REPLACE WIRES	37	44	+43
L486 REMOVE OR REPLACE TRANSISTORS	89	47	+42
L491 SERVICE TORQUE WRENCHES	80	38	+42
L485 REMOVE OR REPLACE TRANSFORMERS	84	42	+42
L453 REMOVE OR REPLACE DIODES OTHER THAN LIGHT EMITTER DIODES (LED)	86	44	+42
L472 REMOVE OR REPLACE PRINTED CIRCUIT BOARDS	92	51	+41
A3 DETERMINE REQUIRMENTS FOR SPACE, PERSONNEL, EQUIPMENT, OR SUPPLIES	17	69	-52
B19 CONDUCT STAFF OR SHOP MEETINGS	15	67	-52
B41 WRITE CORRESPONDENCE	30	80	-50
A1 ASSIGN PERSONNEL TO DUTY POSITIONS	17	67	-50
A2 ASSIGN SPONSORS FOR NEWLY ASSIGNED PERSONNEL	9	56	-47
B24 DIRECT UTILIZATION OF EQUIPMENT	29	73	-44
A18 SCHEDULE LEAVES OR PASSES	17	60	-43
B30 INTERPRET POLICIES, DIRECTIVES, OR PROCEDURES FOR SUBORDINATES	34	76	-42
A15 PLAN WORK ASSIGNMENTS	35	76	-41

TABLE 12

TASKS WHICH BEST DIFFERENTIATE DAFSC 32630D AND 32650D PERSONNEL  
(PERCENT MEMBERS PERFORMING)

<u>TASKS</u>	<u>DAFSC 32630D (N=7)</u>	<u>DAFSC 32650D (N=20)</u>	<u>DIFFERENCE</u>
L449 REMOVE OR REPLACE CAPSTANDS ON MAGNETIC OR PUNCH TAPE UNITS	14	90	-76
L470 REMOVE OR REPLACE PINS ON PLUG CONNECTORS	14	85	-71
L448 REMOVE OR REPLACE CAPACITORS	14	80	-66
L428 CLEAN TAPE HEADS	29	90	-61
L437 PERFORM HIGH VALUE DESOLDERING	29	90	-61
L438 PERFORM HIGH VALUE SOLDERING	29	90	-61
L440 REMOVE OR INSTALL COMPONENTS FROM PRINTED CIRCUIT BOARDS	29	90	-61
L441 REMOVE OR INSTALL DRAWERS FROM TEST STATIONS	29	90	-61
L442 REMOVE OR INSTALL PUNCH TAPE	29	90	-61
L457 REMOVE OR REPLACE FUSES	29	90	-61
L472 REMOVE OR REPLACE PRINTED CIRCUIT BOARDS	29	90	-61
L475 REMOVE OR REPLACE RELAYS	29	90	-61
L486 REMOVE OR REPLACE TRANSISTORS	29	90	-61
L485 REMOVE OR REPLACE TRANSFORMERS	14	75	-61
D70 DEMONSTRATE HOW TO LOCATE TECHNICAL INFORMATION	0	60	-60
E113 MAKE ENTRIES ON SYSTEM/EQUIPMENT STATUS RECORDS (AFTO FORMS 244 and 245)	29	85	-56
L427 CLEAN PINS ON PRINTED CIRCUIT BOARDS	29	85	-56
L439 PERFORM IN-SHOP CIRCUIT CARD TESTS	29	85	-56
L461 REMOVE OR REPLACE INTEGRATED CIRCUITS	29	85	-56
L463 REMOVE OR REPLACE LAMPS	29	85	-56

TABLE 13

TASKS WHICH BEST DIFFERENTIATE DAFSC 32650D AND 32670D PERSONNEL  
(PERCENT MEMBERS PERFORMING)

TASKS	DAFSC 32650D (N=20)	DAFSC 32670D (N=15)	DIFFERENCE
L467 REMOVE OR REPLACE METERS	65	20	+45
L437 PERFORM HIGH VALUE DESOLDERING	90	47	+43
L438 PERFORM HIGH VALUE SOLDERING	90	47	+43
L486 REMOVE OR REPLACE TRANSISTORS	90	47	+43
B41 WRITE CORRESPONDENCE	15	87	-72
C45 EVALUATE COMPLIANCE WITH PERFORMANCE STANDARDS	20	87	-67
E92 MAINTAIN SYSTEM PRODUCTS OTHER THAN MMICS, SUCH AS SUPPLY, PERSONNEL, OR ACCOUNTING SYSTEM PRODUCTS	10	73	-63
A15 PLAN WORK ASSIGNMENTS	35	93	-58
B20 COUNSEL PERSONNEL ON PERSONAL OR MILITARY RELATED PROBLEMS	35	93	-58
C46 EVALUATE INDIVIDUALS FOR PROMOTION, DEMOTION, OR RECLASSIFICATION	10	67	-57
C49 EVALUATE MAINTENANCE OR USE OF WORKSPACE, EQUIPMENT, OR SUPPLIES	10	67	-57
C56 EVALUATE WORK SCHEDULES	10	67	-57
D77 EVALUATE OJT TRAINEES	15	67	-52
D79 EVALUATE TRAINING METHODS OR TECHNIQUES	10	60	-50
B19 CONDUCT STAFF OR SHOP MEETINGS	5	53	-48
B21 DIRECT AVIONICS AEROSPACE GROUND EQUIPMENT (AGE) SHOP FUNCTIONS	25	73	-48
D69 COUNSEL TRAINEES ON TRAINING PROGRESS	35	80	-45
C47 EVALUATE INSPECTION REPORTS OR PROCEDURES	10	53	-43
C51 EVALUATE REQUESTS FOR LIMITED OR SPECIAL CALIBRATION	10	53	-43
B36 SUPERVISE AVIONICS AGE SPECIALISTS (AFSC 32650D)	30	73	-43

## ANALYSIS OF EXPERIENCE (TAFMS) GROUPS

Data from the 326X0C/D career ladder survey were also examined in terms of TAFMS groups to determine how personnel utilization patterns change as a function of experience. Tables 14 and 15 provide a list of the relative amount of time spent on duties by shred in various TAFMS groups. As illustrated, as the number of months of experience increase, overall, respondents reported spending greater percentages of their time performing administrative and supervisory functions. However, even the more experienced incumbents still performed some of the technical functions in varying degrees. For example, incumbents in both the C and D shreds continue to repair and service test sets and stations well into the fourth enlistment period.

### Job Satisfaction

In addition to an analysis of tasks performed, career ladder incumbents in their first enlistment (1-48 months TAFMS), second enlistment (49-96 months TAFMS), and career status (97+ months) were also examined in terms of various job satisfaction indices. As illustrated by Tables 16 and 17 members of this specialty appeared to be highly satisfied with the job which they were performing. Generally, job interest and perceived utilization of talents and training for 326X0C/D personnel were much higher than those of corresponding groups in a comparative sample composed of a number of similar specialties in the Mission Equipment Maintenance area. In addition, when compared to 326X0C incumbents, reenlistment rates for members of the comparative sample across all enlistment groups were somewhat higher. The reverse trend was evident with 326X0D incumbents who, except for the career group (97+ months), indicated higher reenlistment intentions than did members of the comparative sample. Overall, although nearly all job satisfaction indices were high for incumbents in the 326X0C/D career ladder, reenlistment intentions were somewhat low in the 326X0C incumbent group.

### First Enlistment Personnel

For training purposes, the job of first enlistment personnel was also examined in addition to the general TAFMS analysis. Overall, incumbents in the C-shred performed many of the basic tasks related to maintaining F-4/RF-4 manual test sets and adapters and repairing and servicing test sets and stations. First enlistment incumbents in the D-shred were involved in performing many of the basic tasks relating to maintaining A-7D manual test sets, maintaining C-5 manual test sets and adapters, and repairing and servicing test sets and adapters. Many of the tasks were also related to maintaining C-5 self-contained semiautomatic test sets and adapters, particularly troubleshooting and calibration tasks. In both the C- and D-shreds, the tasks were highly oriented toward the particular weapons systems to which incumbents were assigned (See Tables 18 and 19 for representative tasks performed by first enlistment personnel). In terms of distribution across the career ladder, first enlistment incumbents were similarly concentrated in groups which were directly related to the weapons system assigned (see Table 20). Figure 2 presents first enlistment distribution across the career ladder percentage-wise.

FIGURE 2  
DISTRIBUTION OF FIRST ENLISTMENT PERSONNEL ACROSS CAREER LADDER JOBS  
(PERCENT MEMBERS PERFORMING)  
(N=63)

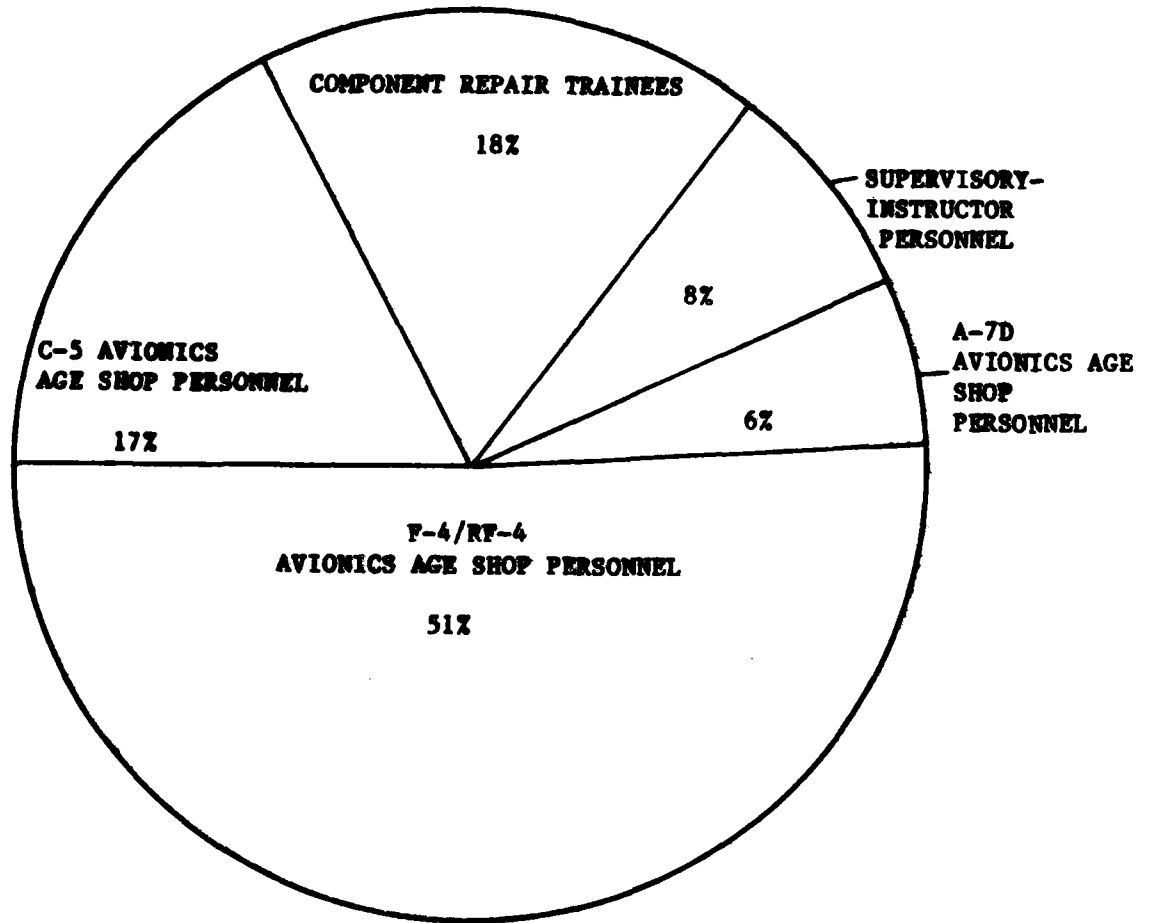

TABLE 14

## RELATIVE TIME SPENT ON DUTIES BY 326X0C TAFMS GROUPS

DUTIES	MONTHS TAFMS					
	1-48 (N=48)	49-96 (N=46)	97-144 (N=26)	145-192 (N=19)	193-240 (N=13)	241+ (N=7)
A ORGANIZING AND PLANNING	1	3	4	7	20	7
B DIRECTING AND IMPLEMENTING	2	4	9	12	21	11
C INSPECTING AND EVALUATING	1	4	6	9	15	12
D TRAINING	3	5	7	13	12	5
E PERFORMING ADMINISTRATIVE OR SUPPLY FUNCTIONS	12	11	14	16	14	24
F MAINTAINING A-7D SEMIAUTOMATIC TEST SETS	0	0	0	0	0	0
G MAINTAINING A-7D MANUAL TEST SETS	0	0	0	0	0	0
H MAINTAINING C-5A SELF-CONTAINED SEMIAUTOMATIC TEST SETS AND ADAPTERS	0	0	0	0	0	0
I MAINTAINING C-5A MANUAL TEST SETS AND ADAPTERS	0	0	0	0	0	0
J MAINTAINING F-4/RF-4 SEMIAUTOMATIC TEST SETS AND ADAPTERS	10	8	8	5	2	4
K MAINTAINING F-4/RF-4 MANUAL TEST SETS AND ADAPTERS	26	30	23	18	8	14
L REPAIRING AND SERVICING TEST SETS AND STATIONS	41	31	25	16	6	20
M PERFORMING AVIONICS AGE GENERAL SHOP MAINTENANCE	4	4	4	4	2	3

TABLE 15  
RELATIVE TIME SPENT ON DUTIES BY 326XOD TAFMS GROUPS

DUTIES	MONTHS TAFMS					
	1-48 (N=15)	49-96 (N=12)	97-144 (N=7)	145-192 (N=5)	193-240 (N=3)	241+ (N=0)
A ORGANIZING AND PLANNING	1	2	7	6	13	
B DIRECTING AND IMPLEMENTING	0	4	13	8	31	
C INSPECTING AND EVALUATING	0	2	8	8	22	
D TRAINING	0	5	9	15	13	
E PERFORMING ADMINISTRATIVE OR SUPPLY FUNCTIONS	10	8	19	12	21	
F MAINTAINING A-7D SENIAUTOMATIC TEST SETS	4	10	4	6	0	
G MAINTAINING A-7D MANUAL TEST SETS	8	14	11	13	0	
H MAINTAINING C-5A SELF-CONTAINED SENIAUTOMATIC TEST SETS AND ADAPTERS	19	7	6	1	0	
I MAINTAINING C-5A MANUAL TEST SETS AND ADAPTERS	33	15	6	3	0	
J MAINTAINING F-4/RF-4 SENIAUTOMATIC TEST SETS AND ADAPTERS	0	0	0	0	0	
K MAINTAINING F-4/RF-4 MANUAL TEST SETS AND ADAPTERS	0	0	0	0	0	
L REPAIRING AND SERVICING TEST SETS AND STATIONS	20	30	15	25	0	
M PERFORMING AVIONICS AGE GENERAL SHOP MAINTENANCE	5	3	2	3	0	

TABLE 16

JOB SATISFACTION DATA FOR 326XOC TAFMS GROUPS  
(PERCENT MEMBERS RESPONDING)

	1-48 MONTHS		49-96 MONTHS		97+ MONTHS	
	326XOC RESPONDENTS (N=48)	1980 COMPARATIVE SAMPLE* (N=1374)	326XOC RESPONDENTS (N=46)	1980 COMPARATIVE SAMPLE* (N=853)	326XOC RESPONDENTS (N=65)	1980 COMPARATIVE SAMPLE* (N=1426)
<u>I FIED BY JOB:</u>						
DULL	6	24	15	17	11	14
SO-SO	8	20	22	22	11	16
INTERESTING	86	56	63	61	78	70
<u>MY JOB UTILIZES MY TALENTS:</u>						
NOT AT ALL TO VERY LITTLE	8	37	15	31	11	24
FAIRLY WELL TO PERFECTLY	92	63	85	69	89	76
<u>MY JOB UTILIZES MY TRAINING:</u>						
NOT AT ALL TO VERY LITTLE	15	30	24	28	11	25
FAIRLY WELL TO PERFECTLY	85	69	76	72	89	74
NOT REPORTED	-	1	-	-	-	1
<u>I PLAN TO REENLIST:</u>						
NO OR PROBABLY NO	73	66	61	51	11	31
YES OR PROBABLY YES	27	33	39	48	65	68
PLAN TO RETIRE (OVER 20 YEARS TAFMS)	-	-	-	-	23	-
NOT REPORTED	-	1	-	1	1	1

\*COMPARATIVE SAMPLE TAKEN FROM ALL MISSION EQUIPMENT MAINTENANCE SPECIALTIES SURVEYED IN 1980; INCLUDES AFSC 30XX, 31XXX, 32XXX 34XXX, 36XXX, 40XXX, 42XXX, 43XXX, 44XXX, 46XXX, AND 46XXX

TABLE 17

JOB SATISFACTION DATA FOR 326XOD TAFMS GROUPS  
(PERCENT MEMBERS RESPONDING)

	1-48 MONTHS		49-96 MONTHS		97+ MONTHS	
	326XOD RESPONDENTS (N=15)	1980 COMPARATIVE SAMPLE* (N=1376)	326XOD RESPONDENTS (N=12)	1980 COMPARATIVE SAMPLE* (N=953)	326XOD RESPONDENTS (N=15)	1980 COMPARATIVE SAMPLE* (N=1626)
<u>I FIND MY JOB:</u>						
BELL	20	24	17	17	-	14
SO-SO	13	20	8	22	27	16
INTERESTING	67	56	75	61	73	70
<u>MY JOB UTILIZES MY TALENTS:</u>						
NOT AT ALL TO VERY LITTLE	13	37	33	31	20	24
FAIRLY WELL TO PERFECTLY	87	63	67	69	80	76
<u>MY JOB UTILIZES MY TRAINING:</u>						
NOT AT ALL TO VERY LITTLE	20	30	8	28	13	25
FAIRLY WELL TO PERFECTLY	80	69	92	72	87	74
NOT REPORTED	-	1	-	-	-	1
<u>I PLAN TO REENLIST:</u>						
NO OR PROBABLY NO	53	66	42	51	27	31
YES OR PROBABLY YES	47	33	50	48	53	68
PLAN TO RETIRE (LOWER 20 YEARS TAFMS)	-	-	-	-	20	-
NOT REPORTED	-	1	8	1	-	1

\*COMPARATIVE SAMPLE TAKEN FROM ALL MISSION EQUIPMENT MAINTENANCE SPECIALTIES SURVEYED IN 1980; INCLUDES AFSCs 30XXX, 31XXX, 32XXX, 34XXX, 36XXX, 40XXX, 42XXX, 43XXX, 44XXX, AND 46XXX

TABLE 18

REPRESENTATIVE TASKS PERFORMED BY 326XOC INCUMBENTS  
WITH 1-48 MONTHS TAFMS

TASKS	PERCENT MEMBERS PERFORMING (N=48)
L472 REMOVE OR REPLACE PRINTED CIRCUIT BOARDS	94
E107 MAKE ENTRIES ON REPARABLE ITEM PROCESSING TAG (AFTO FORM 350)	90
L448 REMOVE OR REPLACE CAPACITORS	90
L426 CALIBRATE TORQUE WRENCHES	88
L491 SERVICE TORQUE WRENCHES	88
L457 REMOVE OR REPLACE FUSES	88
L476 REMOVE OR REPLACE RESISTORS	88
L486 REMOVE OR REPLACE TRANSISTORS	88
L463 REMOVE OR REPLACE LAMPS	85
L488 REMOVE OR REPLACE WIRES	85
L482 REMOVE OR REPLACE SWITCHES	85
E102 MAKE ENTRIES ON MAINTENANCE DATA COLLECTION (MDC) RECORD (AFTO FORM 349)	83
J281 TROUBLESHOOT AN/ASM-442 AIR DATA COMPUTER TEST SETS	83
L475 REMOVE OR REPLACE RELAYS	83
L471 REMOVE OR REPLACE POWER SUPPLIES	83
L453 REMOVE OR REPLACE DIODES OTHER THAN LIGHT EMITTER DIODES (LED)	81
L440 REMOVE OR INSTALL COMPONENTS FROM PRINTED CIRCUIT BOARDS	81
J272 CALIBRATE AN/ASM-442 AIR DATA COMPUTER TEST SETS	79
M492 CLEAN EXTERIORS OF SHOP EQUIPMENT	77
L467 REMOVE OR REPLACE METERS	77
L424 CALIBRATE TORQUE TENSIO METERS	75
J276 TROUBLESHOOT AN/APM-307 INTERCEPTOR CONTROL SYSTEM TEST	75
L470 REMOVE OR REPLACE PINS ON PLUG CONNECTORS	75
K303 CALIBRATE AN/ASM-194 INERTIAL NAVIGATION ELECTRONIC TEST	73
E105 MAKE ENTRIES ON PME CERTIFICATION LABEL (AFTO FORM 108)	71

TABLE 19

REPRESENTATIVE TASKS PERFORMED BY 326X0D INCUMBENTS  
WITH 1-48 MONTHS TAFMS

TASKS	PERCENT MEMBERS PERFORMING (N=15)
E107 MAKE ENTRIES ON REPARABLE ITEM PROCESSING TAG (AFTO FORM 350)	87
M492 CLEAN EXTERIORS OF SHOP EQUIPMENT	87
H190 CALIBRATE 20660001-605A INERTIAL DOPPLER NAVIGATION EQUIPMENT (IDNE) TEST SETS	73
E102 MAKE ENTRIES ON MAINTENANCE DATA COLLECTION (MDC) RECORD (AFTO FORM 349)	73
I247 TROUBLESHOOT 20660200-603A IDNE PORTABLE PROGRAMMERS	73
I216 CALIBRATE 20660200-603A IDNE PORTABLE PROGRAMMERS	73
H196 PERFORM SELF-TESTS OF 2551F0200-4 MADAR SYSTEM TEST SETS	67
H187 CALIBRATE MR1505 TEST SETS	67
H193 PERFORM SELF-TESTS OF MR1505 TEST SETS	67
I217 CALIBRATE 20662000-602A AGE CARD TEST SETS	67
E112 MAKE ENTRIES ON SUPPLY CONTROL LOG (AF FORM 2413)	67
I248 TROUBLESHOOT 20662000-602A AGE CARD TEST SETS	67
I220 CALIBRATE 3608-20000 MULTIMODE RADAR TEST SETS	67
H202 TROUBLESHOOT 2551F0200-4 MADAR SYSTEM TEST SETS	60
I227 CALIBRATE 95-001-04 CENTRAL AIR DATA COMPUTER (CADC) TEST SETS	60
H198 TROUBLESHOOT MR1505 TEST SETS	60
H201 TROUBLESHOOT 20660001-605A IDNE TEST SETS	60
I266 TROUBLESHOOT 95-050-01 BITE TEST SETS	60
I229 CALIBRATE 95-050-01 BUILT-IN TEST EQUIPMENT (BITE) TEST SETS	60
H191 CALIBRATE 2551F0200-4 MALFUNCTION DETECTING AND RECORDING (MADAR) SYSTEM TEST SETS	60
I230 CALIBRATE 951-0044-002 GO-AROUND ATTITUDE SYSTEM (GASS) TEST SETS	60
H192 PERFORM SELF-TESTS OF MR1505 TEST SET ADAPTERS OTHER THAN UG2215B2	60
I267 TROUBLESHOOT 951-0044-002 GASS TEST SETS	60
H186 CALIBRATE MR1505 TEST SET ADAPTERS OTHER THAN UG2215B2	60
I252 TROUBLESHOOT 3608-2000 MULTIMODE RADAR TEST SETS	60

**TABLE 20**

**FIRST ENLISTMENT PERSONNEL DISTRIBUTION ACROSS MAJOR JOB GROUPS**

<b>GROUP</b>	<b>FIRST ENLISTMENT PERSONNEL (N=63)</b>
<b>SUPERVISORY-INSTRUCTOR PERSONNEL</b>	<b>5</b>
<b>F-4/RF-4 AVIONICS AGE SHOP PERSONNEL</b>	<b>32</b>
<b>COMPONENT REPAIR TRAINEES</b>	<b>11</b>
<b>A-7D AVIONICS AGE SHOP PERSONNEL</b>	<b>4</b>
<b>C-5 AVIONICS AGE SHOP PERSONNEL</b>	<b>11</b>

## ANALYSIS OF AFR 39-1 SPECIALTY DESCRIPTIONS

Survey data were compared to the AFR 39-1 Specialty Descriptions for the Avionics Aerospace Ground Equipment (AGE) Specialist and Technician, dated 31 October 1978. The Integrated Avionics Superintendent was not surveyed because this AFSC can be attained from any one of seven related Avionics career ladders.

The specialty description for the Avionics Aerospace Ground Equipment (AGE) Technician accurately reflects the combined technical and supervisory nature of the 7-skill level job. The 3/5-skill level description also appears to be complete and accurately portrays the technical nature of the job.

### SPECIALTY TRAINING

The technical training program for F/RF-4 Peculiar AGE is conducted at Lowry Technical Training Center (LTTC). The course is 16 weeks 3 days long and includes both electronics fundamentals and maintenance of F/RF-4 Category II avionics support equipment.

Electronics Fundamental training for A-7D AGE personnel is provided at Lackland AFB (5 weeks 3 days), with a follow-on training program on A-7D AGE equipment at Davis-Monthan AFB AZ (18 weeks). C-5 AGE personnel are trained via an FTD at Dover AFB DE.

Since A-7 aircraft are being phased out of the active inventory, no analysis was made of the A-7 specialty training standard (STS) or Plan of Instruction (POI). For the F/RF-4 Peculiar AGE (C-shred), a matching of the task list with the STS items was made by training personnel at LTTC. This matching was not requested until late in the project due to an administrative error.

The initial printouts have been returned to LTTC for review and refinement. Analysis of the STS and POI were deferred until a revised matching can be completed. Once the revised matchings are received, a Training Extract will be compiled and distributed.

## MAJCOM COMPARISONS

Tasks and background data for personnel of the major commands (MAJCOM) with the largest populations of 5-skill level incumbents were compared to determine whether job content varied as a function of MAJCOM assignment.

As was true in the Career Ladder Structure section, incumbents grouped around the type of weapons system they worked with and the weapons system the MAJCOM possessed. Table 26 displays the relative time spent on various duty areas (types of weapon systems) by 5-skill level C- and D-shred personnel. Notable major differences are discussed below.

### Tactical Air Forces (TAF) Components

Members of three commands flying the various models of the F-4 fighter aircraft (TAC, USAFE, and PACAF), although displaying some task differences, displayed many similarities. All three commands devoted a relatively high amount of duty time to maintaining F-4/RF-4 manual test sets and adapters and a somewhat lesser amount of duty time maintaining F-4/FR-4 semiautomatic test sets and adapters (see Table 26). This was to be expected in that these duty areas are peculiar to F-4/RF-4 avionics AGE and the personnel assigned to this weapons system are all 326X0C incumbents. There are also TAC personnel who work with the A-7D aircraft; however, these incumbents are D-shred personnel who are involved in maintaining A-7D semiautomatic test sets and maintaining A-7D manual test sets (see Table 21).

### Military Airlift Command (MAC)

MAC personnel, following the weapons system pattern, spend more of their job time performing tasks related to maintaining C-5A self-contained semiautomatic test sets and adapters, and maintaining C-5A manual test sets and adapters. All MAC incumbents hold the 326X0D DAFSC (see Table 21).

Table 22 displays a comparison of background information by shred and MAJCOM, while Table 23 displays job satisfaction data for MAJCOM 5-skill level incumbents.

### Summary

There were differences noted in the jobs performed by personnel across the MAJCOMs. These differences revolve around the unique weapons systems found in each MAJCOM and the related shredouts. Other than management and supervisory duty areas, the only commonality found between MAJCOM and shredouts were in repairing and servicing test sets and stations, and performing avionics AGE general shop maintenance (duty areas L and M). The weapons system peculiar AGE was the prevailing determinate in MAJCOM differences.

TABLE 21

## PERCENTAGE OF TIME SPENT ON DUTIES BY 326X5C/D MAJCOM GROUPS

DUTIES	32650C			32650D	
	TAC (N=36)	USAF (N=31)	PACAF (N=19)	TAC (N=9)	HAC (N=10)
A ORGANIZING AND PLANNING	1	2	4	2	1
B DIRECTING AND IMPLEMENTING	3	3	5	2	2
C INSPECTING AND EVALUATING	3	2	4	2	1
D TRAINING	3	1	4	2	2
E PERFORMING ADMINISTRATIVE OR SUPPLY FUNCTIONS	11	11	15	7	8
F MAINTAINING A-7D SEMIAUTOMATIC TEST SETS	*	*	*	18	*
G MAINTAINING A-7D MANUAL TEST SETS	*	*	*	32	*
H MAINTAINING C-5A SELF-CONTAINED SEMIAUTOMATIC TEST SETS AND ADAPTERS	*	*	*	*	18
I MAINTAINING C-5A MANUAL TEST SETS AND ADAPTERS	*	*	*	*	35
J MAINTAINING F-4/RF-4 SEMIAUTOMATIC TEST SETS AND ADAPTERS	8	6	8	*	*
K MAINTAINING F-4/RF-4 MANUAL TEST SETS AND ADAPTERS	32	35	24	*	*
L REPAIRING AND SERVICING TEST SETS AND STATIONS	36	35	32	32	29
M PERFORMING AVIONICS AGE GENERAL SHOP MAINTENANCE	3	5	4	3	3

\*DENOTES LESS THAN .5 PERCENT

TABLE 22

COMPARISON OF BACKGROUND INFORMATION FOR 32650C/D MAJCOM GROUP

MAJCOM	32650C			32650D	
	TAC	USAFE	PACAF	TAC	MAC
AVERAGE NUMBER OF TASKS PERFORMED:	116	123	145	129	121
AVERAGE PERSONS SUPERVISED:	1	1	2	1	0
AVERAGE MONTHS IN CAREER FIELD:	40	45	47	53	39
AVERAGE MONTHS IN SERVICE:	54	78	76	78	42
PERCENT ASSIGNED TO THE CONUS:	97%	0%	5%	100%	100%
PERCENT MEMBERS IN FIRST ENLISTMENT:	64%	45%	53%	22%	60%

TABLE 23

JOB SATISFACTION DATA FOR 32650C/D PERSONNEL BY MAJCOM GROUPS  
(PERCENT RESPONDING)

	32650C			32650D	
	TAC	USAFE	PACAF	TAC	MAC
<u>I FIND MY JOB:</u>					
DULL	5	19	5	33	10
SO-SO	17	13	32	22	10
INTERESTING	78	68	63	45	80
<u>MY JOB UTILIZES MY TALENTS:</u>					
NOT AT ALL OR VERY LITTLE	3	16	5	56	20
FAIRLY WELL OR BETTER	97	84	95	44	80
<u>MY JOB UTILIZES MY TRAINING:</u>					
NOT AT ALL OR VERY LITTLE	22	19	11	22	10
FAIRLY WELL OR BETTER	78	81	89	78	90
<u>I PLAN TO REENLIST:</u>					
NO, PLAN TO RETIRE	0	0	0	0	0
NO, OR PROBABLY NO	53	55	53	56	50
YES, OR PROBABLY YES	47	45	47	44	50

## ANALYSIS OF CONUS VERSUS OVERSEAS GROUPS

A comparison was made between the tasks performed by DAFSC 32850C personnel stationed within the CONUS and those located overseas. Results indicated that while the job performed by both groups was basically the same, a number of variations did exist. Those respondents who were assigned overseas reported performing a slightly higher average number of tasks than those within the CONUS (125 versus 104). In addition, greater percentages of personnel overseas performed tasks that were related to repairing and servicing test sets and stations than their counterparts in the CONUS. Conversely, CONUS personnel were slightly more involved in performing tasks related to training (see Table 24).

Finally, there were some background differences between the two groups. Overseas respondents are slightly more senior and also reported a higher average time in the service (60 months for overseas incumbents and 58 months for those in the CONUS). Job satisfaction indices were similarly high for both groups and reenlistment intentions were identical with 45 percent indicating they would or probably would reenlist.

No D-shredout personnel are stationed overseas, so a CONUS/overseas comparison is not applicable.

TABLE 24

TASKS WHICH BEST DIFFERENTIATE DAFSC 32650C CONUS AND OVERSEAS PERSONNEL  
(PERCENT MEMBERS PERFORMING)

TASKS	CONUS (N=45)	OVERSEAS (N=53)	DIFFERENCE
D63 ADMINISTER TESTS	27	4	+23
K389 TROUBLESHOOT AN/ASM-84 INTEGRATED ELECTRONIC CENTRAL	33	11	+22
D83 SCORE TESTS	22	2	+20
D82 PROCURE TRAINING AIDS, SPACE, OR EQUIPMENT	22	6	+16
M499 PACK OR UNPACK MOBILITY EQUIPMENT	46	30	+16
E108 MAKE ENTRIES ON REQUEST FOR LIMITED/SPECIAL CALI- BRATION (PME) (AFTO FORM 163)	31	64	-33
L429 CONSTRUCT CABLES OR TEST PLUGS FOR SHOP USE	51	83	-32
L432 LUBRICATE GEARS, CAMS, OR ROTORS	29	60	-31
L430 COORDINATE CALIBRATION OF CATEGORY II EQUIPMENT WITH USERS	42	73	-31
K418 TROUBLESHOOT 53E150525-1 MAVERICK INTERFACE TEST SETS	22	53	-31
L425 CALIBRATE TORQUE WATCHES	22	53	-31
L431 LACE WIRE BUNDLES	51	81	-30
M497 INSPECT SHOP POWER PRODUCTION UNITS	16	43	-27
M501 TRANSPORT EQUIPMENT	36	62	-26
K312 CALIBRATE AN/ASM-247 GYRO BIAS TEST SETS	49	75	-26
L447 REMOVE OR REPLACE BELTS	51	77	-26
M496 FABRICATE TEST WORK BENCHES	29	55	-26
K381 TROUBLESHOOT AN/ASM-247 GYRO BIAS TEST SETS	44	70	-26
L423 APPLY POTTING COMPOUND TO OR REMOVE FROM WIRES	24	49	-25
B35 SUPERVISE AVIONICS AGE SPECIALISTS (AFSC 32650C)	27	51	-24

## COMPARISON TO PREVIOUS SURVEY

The results of this survey were compared to those of the previous Occupational Survey Report AFPT 90-326-083, dated September 1975. A direct comparison was very difficult in that the previous survey covered avionics AGE associated with the C-5A, A-7D/AC-130, F-111A/D/E/F/FB-111A, and F-15. In the present study, only the C-5A, A-7D, and various F-4 models were included due to the restructuring of the career ladder in April 1976 which resulted in the creation of the C- and D-shredouts and removal of the AC-130, F-111, and F-15 weapons systems from this ladder and the addition of the F-4 weapons system. In both the 1975 and 1981 studies, incumbents formed groups related to the weapons system to which they were assigned. A supervisory cluster appeared in both studies as did an instructor job type. Job satisfaction indices were high in both of the occupational surveys, as were reenlistment intentions. Beyond these observations, little direct comparisons can be made.

## WRITE-IN COMMENTS

In addition to responding to the survey questions, incumbents were also encouraged to write in any additional information which may be relevant to the analysis of the 326X0C/D career ladder. This included such items as problems they feel may exist in the career ladder, or tasks and equipment which individual members believe should be added to the job inventory.

Relatively few write-in comments were received. Some of the comments received consisted of unique tasks performed by incumbents, and a few unique equipment items not listed in the job inventory. Other comments mentioned maintaining avionics AGE of other weapons systems such as F-5E, C-130, HC-130, C-141, T-33, and HH-3.

## CONCLUSIONS

This occupational survey was conducted to capture tasks related to F/RF-4 aircraft which were not covered in the 1975 occupational survey, and to verify the career ladder structure as established in April 1976, and modified in October 1978 to include the C-5 avionics aerospace ground equipment. The CAREER LADDER STRUCTURE section demonstrates that, for the most part, the jobs being performed by members of the C-shred and D-shred are appropriate to the type of weapons system maintained. Areas of overlap between the C- and D-shreds were limited to two generalized technical duty areas consisting of repairing and servicing test sets and stations, and performing avionics AGE general shop maintenance. The other technically related duty areas were specific to the weapons system assigned. Since the A-7D AGE equipment is being deleted from the active inventory, the D-shred jobs will be limited to the C-5 system in the future.

Analysis of duty AFSC groups indicates that the vast proportion of time spent on the job by incumbents of the two shredouts are consistent with the present classification structure. No write-in comments by career ladder incumbents indicated dissatisfaction with the present specialty structure and the relatively high job satisfaction indicators were also supportive.

**APPENDIX A**

**REPRESENTATIVE TASKS BY JOB GROUPS**

GROUP I

REPRESENTATIVE TASKS PERFORMED BY SUPERVISORY-INSTRUCTOR  
PERSONNEL (GRP004, N=40)

TASKS	PERCENT MEMBERS PERFORMING
B20 COUNSEL PERSONNEL ON PERSONAL OR MILITARY RELATED PROBLEMS	78
D70 DEMONSTRATE HOW TO LOCATE TECHNICAL INFORMATION	70
B41 WRITE CORRESPONDENCE	65
A15 PLAN WORK ASSIGNMENTS	55
B31 INVENTORY EQUIPMENT, TOOLS, OR SUPPLIES	55
A1 ASSIGN PERSONNEL TO DUTY POSITIONS	55
E115 MAKE ENTRIES ON TEMPORARY ISSUE RECEIPT (AF FORM 1297)	55
B30 INTERPRET POLICIES, DIRECTIVES, OR PROCEDURES FOR SUBORDINATES	53
D69 COUNSEL TRAINEES ON TRAINING PROGRESS	53
C45 EVALUATE COMPLIANCE WITH PERFORMANCE STANDARDS	53
B24 DIRECT UTILIZATION OF EQUIPMENT	50
C60 SELECT INDIVIDUALS FOR SPECIALIZED TRAINING	50
E92 MAINTAIN SYSTEM PRODUCTS OTHER THAN MMICS, SUCH AS SUPPLY, PERSONNEL, OR ACCOUNTING SYSTEM PRODUCTS	48
E107 MAKE ENTRIES ON REPARABLE ITEM PROCESSING TAG (AFTO FORM 350)	48
B19 CONDUCT STAFF OR SHOP MEETINGS	48
A3 DETERMINE REQUIREMENTS FOR SPACE, PERSONNEL, EQUIPMENT, OR SUPPLIES	48
A4 DETERMINE WORK PRIORITIES	48
A9 ESTABLISH PERFORMANCE STANDARDS	43
E112 MAKE ENTRIES ON SUPPLY CONTROL LOG (AF FORM 2413)	43
D63 ADMINISTER TESTS	40
D80 MAINTAIN TRAINING RECORDS, CHARTS, OR GRAPHS	40
C43 ANALYZE WORKLOAD REQUIREMENTS	40
D79 EVALUATE TRAINING METHODS OR TECHNIQUES	40
E118 REVIEW MDC REPORTS	35
D83 SCORE TESTS	33

GROUP Ia

REPRESENTATIVE TASKS PERFORMED BY SUPERVISORY PERSONNEL  
(GRP005, N=31)

<u>TASKS</u>	<u>PERCENT MEMBERS PERFORMING</u>
B41 WRITE CORRESPONDENCE	84
B20 COUNSEL PERSONNEL ON PERSONAL OR MILITARY RELATED PROBLEMS	77
A15 PLAN WORK ASSIGNMENTS	71
B31 INVENTORY EQUIPMENT, TOOLS, OR SUPPLIES	65
A1 ASSIGN PERSONNEL TO DUTY POSITIONS	65
A4 DETERMINE WORK PRIORITIES	61
D70 DEMONSTRATE HOW TO LOCATE TECHNICAL INFORMATION	61
B30 INTERPRET POLICIES, DIRECTIVES, OR PROCEDURES FOR SUBORDINATES	61
B24 DIRECT UTILIZATION OF EQUIPMENT	61
C45 EVALUATE COMPLIANCE WITH PERFORMANCE STANDARDS	61
A3 DETERMINE REQUIREMENTS FOR SPACE, PERSONNEL, EQUIPMENT, OR SUPPLIES	61
C59 PREPARE APRs	61
E92 MAINTAIN SYSTEM PRODUCTS OTHER THAN MMICS, SUCH AS SUPPLY, PERSONNEL, OR ACCOUNTING SYSTEM PRODUCTS	58
B19 CONDUCT STAFF OR SHOP MEETINGS	58
C56 EVALUATE WORK SCHEDULES	58
E115 MAKE ENTRIES ON TEMPORARY ISSUE RECEIPT (AF FORM 1297)	58
E107 MAKE ENTRIES ON REPARABLE ITEM PROCESSING TAG (AFTO FORM 350)	55
A9 ESTABLISH PERFORMANCE STANDARDS	55
E112 MAKE ENTRIES ON SUPPLY CONTROL LOG (AF FORM 2413)	55
C43 ANALYZE WORKLOAD REQUIREMENTS	52
B21 DIRECT AVIONICS AEROSPACE GROUND EQUIPMENT (AGE) SHOP FUNCTIONS	52
E100 MAKE ENTRIES ON ISSUE/TURN IN REQUEST (AF FORM 2005)	52
E90 MAINTAIN MAINTENANCE MANAGEMENT INFORMATION AND CONTROL SYSTEM (MMICS) PRODUCTS	52
A6 DEVELOP WORK METHODS OR PROCEDURES	45
E118 REVIEW MDC REPORTS	42

GROUP Ib

REPRESENTATIVE TASKS PERFORMED BY INSTRUCTOR PERSONNEL  
(GRP013, N=9)

TASKS	PERCENT MEMBERS PERFORMING
D70 DEMONSTRATE HOW TO LOCATE TECHNICAL INFORMATION	100
D83 SCORE TESTS	100
D63 ADMINISTER TESTS	100
D67 CONDUCT RESIDENT COURSE CLASSROOM TRAINING	78
B20 COUNSEL PERSONNEL ON PERSONAL OR MILITARY RELATED PROBLEMS	78
J276 TROUBLESHOOT AN/APM-307 INTERCEPTOR CONTROL SYSTEM TEST SETS	78
J272 CALIBRATE AN/ASM-442 AIR DATA COMPUTER TEST SETS	67
D84 WRITE TEST QUESTIONS	67
J281 TROUBLESHOOT AN/ASM-442 AIR DATA COMPUTER TEST SETS	67
J274 CALIBRATE AN/AWM-20 FIRE CONTROL SYSTEM TEST SETS	67
J268 CALIBRATE AN/APM-307 INTERCEPTOR CONTROL SYSTEM TEST SETS	67
J283 TROUBLESHOOT AN/AWM-20 FIRE CONTROL SYSTEMS TEST SETS	67
D82 PROCURE TRAINING AIDS, SPACE, OR EQUIPMENT	56
K287 CALIBRATE AN/AJM-17 COMPUTER TEST SETS	56
K356 TROUBLESHOOT AN/AJM-17 COMPUTER TEST SETS	56
D80 MAINTAIN TRAINING RECORDS, CHARTS, OR GRAPHS	44
E93 MAINTAIN TO OR PUBLICATION LIBRARIES	44
B33 SUPERVISE APPRENTICE AVIONICS AGE SPECIALISTS (AFSC 32630C)	44
D69 COUNSEL TRAINEES ON TRAINING PROGRESS	44
L441 REMOVE OR INSTALL DRAWERS FROM TEST STATIONS	44
E115 MAKE ENTRIES ON TEMPORARY ISSUE RECEIPT (AF FORM 1297)	44
C60 SELECT INDIVIDUALS FOR SPECIALIZED TRAINING	33
D79 EVALUATE TRAINING METHODS OR TECHNIQUES	33
E114 MAKE ENTRIES ON TECHNICAL ORDER SYSTEM PUBLICATION IMPROVEMENT REPORT (AFTO FORM 22)	33
L472 REMOVE OR REPLACE PRINTED CIRCUIT BOARDS	33

GROUP II

REPRESENTATIVE TASKS PERFORMED BY F-4/RF-4 AVIONICS AGE SHOP PERSONNEL  
(GRP018, N=110)

<u>TASKS</u>	<u>PERCENT MEMBERS PERFORMING</u>
L472 REMOVE OR REPLACE PRINTED CIRCUIT BOARDS	97
E107 MAKE ENTRIES ON REPARABLE ITEM PROCESSING TAG (AFTO FORM 350)	97
L486 REMOVE OR REPLACE TRANSISTORS	97
L448 REMOVE OR REPLACE CAPACITORS	96
L476 REMOVE OR REPLACE RESISTORS	95
L482 REMOVE OR REPLACE SWITCHES	95
L475 REMOVE OR REPLACE RELAYS	95
J281 TROUBLESHOOT AN/ASM-442 AIR DATA COMPUTER TEST SETS	94
L426 CALIBRATE TORQUE WRENCHES	93
E102 MAKE ENTRIES ON MAINTENANCE DATA COLLECTION (MDC) RECORD (AFTO FORM 349)	93
L457 REMOVE OR REPLACE FUSES	93
L440 REMOVE OR INSTALL COMPONENTS FROM PRINTED CIRCUIT BOARDS	93
L463 REMOVE OR REPLACE LAMPS	92
E105 MAKE ENTRIES ON PME CERTIFICATION LABEL (AFTO FORM 108)	90
J272 CALIBRATE AN/ASM-442 AIR DATA COMPUTER TEST SETS	87
M492 CLEAN EXTERIORS OF SHOP EQUIPMENT	87
L491 SERVICE TORQUE WRENCHES	86
K303 CALIBRATE AN/ASM-194 INERTIAL NAVIGATION ELECTRONIC TEST	85
E112 MAKE ENTRIES ON SUPPLY CONTROL LOG (AF FORM 2413)	85
L437 PERFORM HIGH VALUE DESOLDERING	83
E100 MAKE ENTRIES ON ISSUE/TURN IN REQUEST (AF FORM 2005)	81
K372 TROUBLESHOOT AN/ASM-194 INERTIAL NAVIGATION ELECTRONIC	80
L430 COORDINATE CALIBRATION OF CATEGORY II EQUIPMENT WITH USERS	74
J274 CALIBRATE AN/AWM-20 FIRE CONTROL SYSTEM TEST SETS	69

GROUP IIa

REPRESENTATIVE TASKS PERFORMED BY AVIONICS AGE SHOP CHIEFS  
(GRP047, N=47)

TASKS	PERCENT MEMBERS PERFORMING
E102 MAKE ENTRIES ON MAINTENANCE DATA COLLECTION (MDC) RECORD (AFTO FORM 349)	98
L486 REMOVE OR REPLACE TRANSISTORS	98
E107 MAKE ENTRIES ON REPARABLE ITEM PROCESSING TAG (AFTO FORM 350)	98
L488 REMOVE OR REPLACE WIRES	98
L457 REMOVE OR REPLACE FUSES	98
L482 REMOVE OR REPLACE SWITCHES	98
L430 COORDINATE CALIBRATION OF CATEGORY II EQUIPMENT WITH USERS	96
L472 REMOVE OR REPLACE PRINTED CIRCUIT BOARDS	96
B31 INVENTORY EQUIPMENT, TOOLS, OR SUPPLIES	96
E99 MAKE ENTRIES ON EQUIPMENT CONDITION TAG OR LABEL (DD FORMS 1574 THROUGH 1577-3)	96
L453 REMOVE OR REPLACE DIODES OTHER THAN LIGHT EMITTER DIODES (LED)	96
L440 REMOVE OR INSTALL COMPONENTS FROM PRINTED CIRCUIT BOARDS	96
L476 REMOVE OR REPLACE RESISTORS	96
L471 REMOVE OR REPLACE POWER SUPPLIES	96
L475 REMOVE OR REPLACE RELAYS	96
E105 MAKE ENTRIES ON PME CERTIFICATION LABEL (AFTO FORM 108)	94
E112 MAKE ENTRIES ON SUPPLY CONTROL LOG (AF FORM 2413)	94
M492 CLEAN EXTERIORS OF SHOP EQUIPMENT	94
L426 CALIBRATE TORQUE WRENCHES	92
J281 TROUBLESHOOT AN/ASM-442 AIR DATA COMPUTER TEST SETS	92
E100 MAKE ENTRIES ON ISSUE/TURN IN REQUEST (AF FORM 2005)	89
M494 COORDINATE CALIBRATION OF AVIONICS AGE SHOP TEST EQUIPMENT WITH PMEL	87
J272 CALIBRATE AN/ASM-442 AIR DATA COMPUTER TEST SETS	87
L491 SERVICE TORQUE WRENCHES	85
L443 REMOVE OR INSTALL TEST SETS	81

GROUP IIB

REPRESENTATIVE TASKS PERFORMED BY COMPONENT REPAIR PERSONNEL  
(GRP049, N=57)

<u>TASKS</u>	<u>PERCENT MEMBERS PERFORMING</u>
L472 REMOVE OR REPLACE PRINTED CIRCUIT BOARDS	100
L426 CALIBRATE TORQUE WRENCHES	98
E107 MAKE ENTRIES ON REPARABLE ITEM PROCESSING TAG (AFTO FORM 350)	98
L486 REMOVE OR REPLACE TRANSISTORS	98
L485 REMOVE OR REPLACE TRANSFORMERS	98
L471 REMOVE OR REPLACE POWER SUPPLIES	98
L476 REMOVE OR REPLACE RESISTORS	96
L488 REMOVE OR REPLACE WIRES	96
L475 REMOVE OR REPLACE RELAYS	96
L482 REMOVE OR REPLACE SWITCHES	96
L448 REMOVE OR REPLACE CAPACITORS	96
L491 SERVICE TORQUE WRENCHES	95
L457 REMOVE OR REPLACE FUSES	95
J281 TROUBLESHOOT AN/ASH-442 AIR DATA COMPUTER TEST SETS	95
L453 REMOVE OR REPLACE DIODES OTHER THAN LIGHT EMITTER DIODES (LED)	95
L463 REMOVE OR REPLACE LAMPS	95
L440 REMOVE OR INSTALL COMPONENTS FROM PRINTED CIRCUIT BOARDS	93
K303 CALIBRATE AN/ASH-194 INERTIAL NAVIGATION ELECTRONIC TEST	91
E102 MAKE ENTRIES ON MAINTENANCE DATA COLLECTION (MDC) RECORD (AFTO FORM 349)	89
J274 CALIBRATE AN/AWM-20 FIRE CONTROL SYSTEM TEST SETS	88
K372 TROUBLESHOOT AN/ASH-194 INERTIAL NAVIGATION ELECTRONIC	86
E105 MAKE ENTRIES ON PME CERTIFICATION LABEL (AFTO FORM 108)	86
J283 TROUBLESHOOT AN/AWM-20 FIRE CONTROL SYSTEM TEST SETS	86
L438 PERFORM HIGH VALUE SOLDERING	86
L437 PERFORM HIGH VALUE DESOLDERING	86

GROUP III

REPRESENTATIVE TASKS PERFORMED BY COMPONENT REPAIR TRAINEES  
(GRP028, N=14)

TASKS	PERCENT MEMBERS PERFORMING
L476 REMOVE OR REPLACE RESISTORS	100
L426 CALIBRATE TORQUE WRENCHES	93
E107 MAKE ENTRIES ON REPARABLE ITEM PROCESSING TAG (AFTO FORM 350)	93
L457 REMOVE OR REPLACE FUSES	93
L486 REMOVE OR REPLACE TRANSISTORS	93
L475 REMOVE OR REPLACE RELAYS	93
E102 MAKE ENTRIES ON MAINTENANCE DATA COLLECTION (MDC) RECORD (AFTO FORM 349)	86
L472 REMOVE OR REPLACE PRINTED CIRCUIT BOARDS	86
L482 REMOVE OR REPLACE SWITCHES	86
L448 REMOVE OR REPLACE CAPACITORS	86
L491 SERVICE TORQUE WRENCHES	79
L463 REMOVE OR REPLACE LAMPS	79
L488 REMOVE OR REPLACE WIRES	79
L453 REMOVE OR REPLACE DIODES OTHER THAN LIGHT EMITTED DIODES (LED)	79
E100 MAKE ENTRIES ON ISSUE/TURN IN REQUEST (AF FORM 2005)	71
E105 MAKE ENTRIES ON PME CERTIFICATION LABEL (AFTO FORM 108)	71
L424 CALIBRATE TORQUE TENSOMETERS	71
J272 CALIBRATE AN/ASMP-442 AIR DATA COMPUTER TEST SETS	71
L471 REMOVE OR REPLACE POWER SUPPLIES	71
L485 REMOVE OR REPLACE TRANSFORMERS	71
J274 CALIBRATE AN/ANM-20 FIRE CONTROL SYSTEM TEST SETS	64
L440 REMOVE OR INSTALL COMPONENTS FROM PRINTED CIRCUIT BOARDS	64
K303 CALIBRATE AN/ASN-194 INERTIAL NAVIGATION ELECTRONIC TEST	64
M492 CLEAN EXTERIORS OF SHOP EQUIPMENT	57
L470 REMOVE OR REPLACE PINS ON PLUG CONNECTORS	57

GROUP IV

REPRESENTATIVE TASKS PERFORMED BY A-7D AVIONICS AGE SHOP PERSONNEL  
(GRP072, N=14)

TASKS	PERCENT MEMBERS PERFORMING
F123 ALIGN 500RM TALLY PUNCHED TAPE READERS	100
F136 PERFORM SELF-TESTS OF AN/AVM-11A HUD TEST SETS	100
L472 REMOVE OR REPLACE PRINTED CIRCUIT BOARDS	100
F133 PERFORM FAULT ISOLATION OF 500 RM TALLY PUNCHED TAPE READERS	100
G144 ALIGN AN/APM-336 VIDEO SERVO TEST SETS	100
L428 CLEAN TAPE HEADS	100
F131 PERFORM FAULT ISOLATION OF AN/AFM-11A HUD TEST SETS	100
L449 REMOVE OR REPLACE CAPSTANDS ON MAGNETIC OR PUNCH TAPE UNITS	100
L475 REMOVE OR REPLACE RELAYS	100
G143 ALIGN AN/APM-335 ANTENNA RECEIVER TEST SETS	100
L442 REMOVE OR INSTALL PUNCH TAPE	100
F134 PERFORM SELF-TESTS OF AN/ASM-375 IMS TEST SETS	100
F121 ALIGN AN/AVM-11A HEADS-UP DISPLAY (HUD) TEST SETS	100
F135 PERFORM SELF-TESTS OF AN/ASM-403 NWDC TEST SETS	100
F120 ALIGN AN/ASM-403 NAVIGATION WEAPONS DELIVERY COMPUTER (NWDC) TEST SETS	100
L486 REMOVE OR REPLACE TRANSISTORS	100
L438 PERFORM HIGH VALUE SOLDERING	100
G175 PERFORM MINIMUM PERFORMANCE TESTS OF AN/APM-336 VIDEO SERVO TEST SETS	93
G183 PERFORM SELF-TEST OF AN/APM-336 VIDEO SERVO TEST SETS	93
F128 CALIBRATE 500RM TALLY PUNCHED TAPE READERS	93
G182 PERFORM SELF-TESTS OF AN/APM-335 ANTENNA RECEIVER TEST	93
F119 ALIGN AN/ASM-375 INERTIAL MEASUREMENT SET (IMS) TEST SETS	93
G176 PERFORM MINIMUM PERFORMANCE TESTS OF AN/APM-341 DOPPLER TEST SETS	93
L470 REMOVE OR REPLACE PINS ON PLUG CONNECTORS	93
G174 PERFORM MINIMUM PERFORMANCE TESTS OF AN/APM-335 ANTENNA RECEIVER TEST SETS	93

GROUP V

REPRESENTATIVE TASKS PERFORMED BY C-5 AVIONICS AGE SHOP PERSONNEL  
(GRPO20, N=20)

TASKS	PERCENT MEMBERS PERFORMING
I247 TROUBLESHOOT 20660200-603A IDNE PORTABLE PROGRAMMERS	100
I216 CALIBRATE 20660200-603A IDNE PORTABLE PROGRAMMERS	100
H190 CALIBRATE 20660001-605A INERTIAL DOPPLER NAVIGATION EQUIPMENT (IDNE) TEST SETS	95
I217 CALIBRATE 20662000-602A AGE CARD TEST SETS	95
I248 TROUBLESHOOT 20662000-602A AGE CARD TEST SETS	95
H194 PERFORM SELF-TEST OF T-170 AC SYSTEM TEST SETS	95
I220 CALIBRATE 3608-20000 MULTIMODE RADAR TEST SETS	95
H191 CALIBRATE 2551F0200-4 MALFUNCTIONS DETECTING AND RECORDING (MADAR) SYSTEM TEST SETS	90
H196 PERFORM SELF-TESTS OF 2551F0200-4 MADAR SYSTEM TEST SETS	90
H192 PERFORM SELF-TEST OF MR1505 TEST SET ADAPTERS OTHER THAN UG2215B2	90
H193 PERFORM SELF-TESTS OF MR1505 TEST SETS	90
H187 CALIBRATE MR1505 TEST SETS	90
H186 CALIBRATE MR1505 TEST SET ADAPTERS OTHER THAN UG2215B2	90
I263 TROUBLESHOOT 8010000196-1 TACAN TEST SETS	90
I227 CALIBRATE 95-001-04 CENTRAL AIR DATA COMPUTER (CADC) TEST SETS	90
I230 CALIBRATE 951-0044-002 GO-AROUND ATTITUDE SYSTEM (GASS) TEST SETS	90
I267 TROUBLESHOOT 951-0044-002 GASS TEST SETS	90
I266 TROUBLESHOOT 95-050-01 BITE TEST SETS	90
H189 CALIBRATE UG2215B2 ELECTRONIC SYSTEMS ADAPTERS	90
I229 CALIBRATE AN/ASM-153 AUTO PILOT TEST BENCH SETS	90
H188 CALIBRATE T-170 AC SYSTEM TEST SETS	90
I212 CALIBRATE 10000A410 CRASH DATA POSITION INDICATOR-RECORDER SUBSYSTEM TEST SETS	90
E107 MAKE ENTRIES ON REPARABLE ITEM PROCESSING TAG (AFTO FORM 350)	85
H202 TROUBLESHOOT 2551F0200-4 MADAR SYSTEM TEST SETS	85
M492 CLEAN EXTERIORS OF SHOP EQUIPMENT	85