

AD-A113 240

NATIONAL OCEANIC AND ATMOSPHERIC ADMINISTRATION BOUL--ETC F/6 4/2
FREQUENCY RESPONSE MEASUREMENTS ON LYMAN-ALPHA HUMIDIOMETERS.(U)
FEB 82 J T PRIESTLEY, W D CARTWRIGHT ARO-55-81

UNCLASSIFIED

NOAA-TM-ERL-WPL-92

ARO-18029.1-65

NL

[OF]
ATA
A66



				END
				DATE
				FILED
				04-82
				DTIC

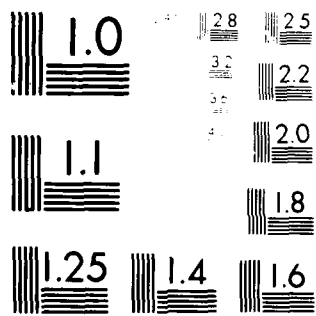

MICROCOPY RESOLUTION TEST CHART
NATIONAL BUREAU OF STANDARDS-1963-A

ARO 18029.1-AS

(11)



NOAA Technical Memorandum ERL WPL-92

AD A113240

FREQUENCY RESPONSE MEASUREMENTS
ON LYMAN-ALPHA HUMIDIOMETERS

J. T. Priestley
W. D. Cartwright

Wave Propagation Laboratory
Boulder, Colorado
February 1982

DTIC
ELECTE
S APR 12 1982 D
E

DTIC FILE COPY

noaa NATIONAL OCEANIC AND
ATMOSPHERIC ADMINISTRATION

Environmental Research
Laboratories

This document has been approved
for public release and sales its
distribution is unlimited.

82 04 12 028

REPORT DOCUMENTATION PAGE		READ INSTRUCTIONS BEFORE COMPLETING FORM	
1. REPORT NUMBER	2. GOVT ACCESSION NO. AD-A113240	3. RECIPIENT'S CATALOG NUMBER	
4. TITLE (and Subtitle) FREQUENCY RESPONSE MEASUREMENTS ON LYMAN-ALPHA HUMIDIMETERS		5. TYPE OF REPORT & PERIOD COVERED	
		6. PERFORMING ORG. REPORT NUMBER	
7. AUTHOR(s) J. T. Priestley W. D. Cartwright		8. CONTRACT OR GRANT NUMBER(s) ARO 55-81	
9. PERFORMING ORGANIZATION NAME AND ADDRESS National Oceanic and Atmospheric Administration Environmental Research Laboratories Boulder, Colorado 80303		10. PROGRAM ELEMENT, PROJECT, TASK AREA & WORK UNIT NUMBERS	
11. CONTROLLING OFFICE NAME AND ADDRESS U. S. Army Research Office Post Office Box 12211 Research Triangle Park, NC 27709		12. REPORT DATE February 1982	
		13. NUMBER OF PAGES 11	
14. MONITORING AGENCY NAME & ADDRESS (if different from Controlling Office)		15. SECURITY CLASS. (of this report) Unclassified	
		15a. DECLASSIFICATION/DOWNGRADING SCHEDULE	
16. DISTRIBUTION STATEMENT (of this Report) Approved for public release; distribution unlimited.			
17. DISTRIBUTION STATEMENT (of the abstract entered in Block 20, if different from Report)			
18. SUPPLEMENTARY NOTES THE VIEW, OPINIONS, AND/OR FINDINGS CONTAINED IN THIS REPORT ARE THOSE OF THE AUTHOR(S) AND SHOULD NOT BE CONSTRUED AS AN OFFICIAL DEPARTMENT OF THE ARMY POSITION, POLICY, OR DE- CISION, UNLESS SO DESIGNATED BY OTHER DOCUMENTATION.			
19. KEY WORDS (Continue on reverse side if necessary and identify by block number) 1. Humidiometer 2. Lyman Alpha 3. Frequency Response 4. Humidity Fluctuations			
20. ABSTRACT (Continue on reverse side if necessary and identify by block number) The primary instrument used for measuring high-frequency humidity fluctuations is the Lyman-alpha humidimeter; yet, there is virtually no published data on its frequency response. Attempting to fill this void, both amplitude and phase measurements were made on several such instruments. These measurements showed frequency responses (amplitude 3 dB down) ranging from approximately 160 to 800 Hz. Measurements of a specially modified unit showed no funda- mental frequency limitation up to at least 10 kHz.			

NOAA Technical Memorandum ERL WPL-92

FREQUENCY RESPONSE MEASUREMENTS
ON LYMAN-ALPHA HUMIDIMETERS

J. T. Priestley
W. D. Cartwright

Partial support for this project was provided
by the U.S. Army Research Office

Wave Propagation Laboratory
Boulder, Colorado
February 1982

Accession For	
NTIS GRA&I	<input checked="" type="checkbox"/>
DTIC TAB	<input type="checkbox"/>
Unannounced	<input type="checkbox"/>
Justification	
By _____	
Dist _____	
Availability Codes	
Avail and/or	
Dist	Special



UNITED STATES
DEPARTMENT OF COMMERCE

Malcolm Baldrige,
Secretary

NATIONAL OCEANIC AND
ATMOSPHERIC ADMINISTRATION

John V. Byrne,
Administrator

Environmental Research
Laboratories

George H. Ludwig
Director

NOTICE

Mention of a commercial company or product does not constitute an endorsement by NOAA Environmental Research Laboratories. Use for publicity or advertising purposes of information from this publication concerning proprietary products or the tests of such products is not authorized.

CONTENTS

	PAGE
ABSTRACT	1
1. The Problem	1
2. Results	2
3. Humidiometer Comparisons	2
4. An Improved Detector Amplifier Design	4
5. Conclusions	4
6. Acknowledgments	4
REFERENCES	5

FREQUENCY RESPONSE MEASUREMENTS ON LYMAN-ALPHA HUMIDIOMETERS

J. T. Priestley and W. D. Cartwright

NOAA/ERL/Wave Propagation Laboratory
Boulder, Colorado 80303

The primary instrument used for measuring high-frequency humidity fluctuations is the Lyman-alpha humidimeter; yet, there is virtually no published data on its frequency response. Attempting to fill this void, both amplitude and phase measurements were made on several such instruments. These measurements showed frequency responses (amplitude 3 dB down) ranging from approximately 160 to 800 Hz. Measurements of a specially modified unit showed no fundamental frequency limitation up to at least 10 kHz.

1. THE PROBLEM

During the summer of 1981, William Kohsiek, a visiting fellow from the Royal Netherlands Meteorological Institute, made a series of simultaneous temperature/humidity measurements in the boundary layer. The temperature sensor was a 2- μ -diameter platinum wire, and the humidity sensor was a Lyman-alpha humidimeter. The results of spectral and cross-spectral analysis of the data indicated a consistent and unexplained anomaly starting at about 20 Hz and gradually increasing toward 100 Hz, the highest frequency analyzed. In the power spectra, the anomaly was a more rapid drop-off in the humidity spectra than that in the temperature spectra. (At 50 Hz the humidity was down about 3 dB compared with the temperature.) In the phase spectra, the anomaly was a systematic phase difference between temperature and humidity going from almost no mismatch at 20 Hz to an approximately 180° mismatch at 100 Hz.

Upon further investigation, we found that very little data were available on the frequency response characteristics of Lyman-alpha humidimeters, in spite of the fact that the Lyman-alpha humidimeter is essentially the only fast-response humidity-measuring instrument currently available. Tillman (1965), in describing the nitric oxide photoionization detector (as used in all of the Lyman-alpha humidimeters investigated in this report), states, "The response time of this detector is presently unknown but probably is on the order of 0.001 seconds." Buck (1976), in describing a Lyman-alpha humidimeter developed at the National Center for Atmospheric Research, states that its response time is 12 ms. He does not indicate the cause of this particular response time nor how it was measured. The only actual response curves we found were in an unpublished report by Friehe (1978). His results are discussed in Section 3 of this report.

In the hope of resolving the immediate problem, as well as achieving a better understanding of the Lyman-alpha humidimeter frequency response characteristics for future users, we made amplitude/phase response measurements of a number of existing instruments, and of one that we modified.

2. RESULTS

We conclude from our measurements that the anomaly in Kohsiek's data was not caused by the frequency response of his Lyman-alpha humidimeter; the frequency response of his humidimeter corresponded to that of a simple RC filter up to the 3-dB point of 490 Hz.

All of the other Lyman-alpha humidimeters that we tested, except one, had 3-dB cut-off frequencies between 160 and 800 Hz, and appeared to be limited by their detector amplifiers. The one exception was a humidimeter for which we built an extended-range detector amplifier. It had a frequency response extending beyond 10 kHz, which is important because it shows that there is no fundamental limitation, at least up to 10 kHz, in the response of Lyman-alpha humidimeters. A response to 10 kHz may be desirable for aircraft-mounted instruments.

3. HUMIDIOMETER COMPARISONS

The experimental arrangement is shown in Fig. 1. The Lyman-alpha source was modulated with a sine wave of approximately 10 to 15 v (peak-to-peak amplitude) and the observed signal was taken from the detector amplifier. Particular attention had to be exercised in the way the reference signal was derived. Taking the reference signal directly from the oscillator output would have required an excessively large blocking capacitor C_1 , because of the relatively low and ill-defined AC impedance of the Lyman-alpha source. With the circuit as shown in Fig. 1, the capacitor C_2 sees the relatively high and well-defined impedance (.5 M Ω) of the scope and phase meter in parallel. This causes a worst-case error of approximately 0.1% in amplitude and 2° in phase. (The worst-case error occurs at the lowest frequency measured, 20 Hz.)

The humidimeter used by Kohsiek was tested using the above procedure. The resulting response curves, along with the circuit diagram of the detector amplifier, are shown in Fig. 2. The 3-dB amplitude point occurs at 490 Hz. The phase at this point is 45°; thus, below the cut-off frequency $f_c = 490$ Hz, the response appears to behave like a simple RC filter with a time constant

$$\tau = \frac{1}{2\pi f_c} = 0.325 \text{ ms}$$

We note from Fig. 2 that the 100-M Ω resistor and the 3-pF capacitor in the feedback loop correspond to a simple RC filter with a time constant $\tau = 0.3$ ms. The slightly larger time constant from the response curves is easily accounted for by component tolerance and stray capacitance on the circuit board. In the 1000- to 2000-Hz region, the response curves depart from those of a simple RC filter: the amplitude response curve falls off more rapidly than 6 dB per octave, and the phase response does not asymptotically approach 90°. This departure is probably caused by the intrinsic frequency characteristics of the op-amp.

When we compare the results of Fig. 2 (no perceptible roll-off at 50 Hz and a 12° phase shift at 100 Hz) with the unexplained anomaly in Kohsiek's experimental data (a 3-dB roll-off at 50 Hz and a 180° phase shift at 100 Hz), it is evident that the frequency response of the humidimeter is not the explanation.

We obtained two Lyman-alpha humidimeters from the Boulder Atmospheric Observatory (Model LA-3 made by the Research Systems Facility of the National Center for Atmospheric Research). The critical part of the detector amplifiers and the response curves for one of the instruments are shown in Fig. 3; the response curve of the other was very similar. The 3-dB amplitude point, as well as the 45° phase point, are close to 150 Hz, which closely corresponds to the cut-off frequency expected from the components in the feedback loop of the op-amp.

$$f_c = \frac{1}{2\pi RC} = 159 \text{ Hz}$$

Arden Buck, of the National Center for Atmospheric Research, loaned us a two-channel experimental Lyman-alpha humidimeter. Fig. 4 shows the response curves and the detector amplifier schematic for channel 1, and Fig. 5 gives similar information for channel 2. (Note the difference in feedback resistors.) The large peak in each of the amplitude response curves is apparently caused by the presence of capacitor C_2 .*

Friehe (1978), made response measurements, similar to those made here, on a commercial (ERC Company) Lyman-alpha humidimeter and also on a modified version with a specially designed, improved, detector amplifier. He found the 3-dB cut-off points to be 1.7 kHz and 3.6 kHz, respectively. Although his modified version was an improvement over the commercial version, he apparently expected a greater improvement because he concluded the response was limited by some fundamental property of the photo-detector.

* Capacitors C_1 and C_2 , as well as the 10-k Ω resistor, are part of a gain-switching network. The schematic diagrams in Figs. 4 and 5 show the configuration used in the present measurements (it corresponds to the lowest gain setting).

4. AN IMPROVED DETECTOR AMPLIFIER DESIGN

We now approached the problem of Lyman-alpha frequency response a little differently: instead of asking what was available, we asked what would we like to have available. From this viewpoint we assumed that we wanted to measure scale sizes down to 1 cm (the physical size limitation of current Lyman-alphas) from an aircraft flying at 100 m s^{-1} . This translates into a frequency response requirement in the order of 10 kHz, significantly exceeding that of the best instrument measured to date.

At this point, we wanted to know if the frequency response was limited by some fundamental characteristic of the photo-detector, for example, the finite drift velocity of positive ions toward the cathode. Attempting to resolve this question, we built a new detector amplifier and substituted it into channel 1 of Buck's humidimeter. The resulting response (Fig. 6) extended to 10 kHz, with less than a 2-dB variation in amplitude and 10° variation in phase.

5. CONCLUSIONS

The primary conclusions are that the anomaly in Kohsiek's data was not caused by the Lyman-alpha humidimeter, and that, with proper design, the frequency response of these instruments can be extended to at least 10 kHz. Any fundamental limitations that may exist are beyond that.

6. ACKNOWLEDGMENTS

We are indebted to A. Buck for his encouragement as well as for the loan of an experimental Lyman-alpha humidimeter. We also gratefully acknowledge the helpful discussions with C. Friehe.

REFERENCES

- Buck, A. L., 1976. The variable-path Lyman-alpha hygrometer and its operating characteristics. Bulletin of the American Meteorological Society, Vol. 57, No. 9, 1113-1118.
- Friehe, C. A., 1978. Performance of the Lyman-alpha humidimeter. (Unpublished at this time but may be published in 1982 as a technical memorandum by the National Center for Atmospheric Research, Boulder, Colorado.)
- Tillman, J. E., 1965. Water vapor density measurements utilizing the absorption of vacuum ultraviolet and infrared radiation. In Humidity and Moisture, Measurement and Control in Science and Industry, Vol. 1, Principles and Methods of Measuring Humidity in Gases, R. E. Ruskin, Ed., Reinhold, New York, 428-443.

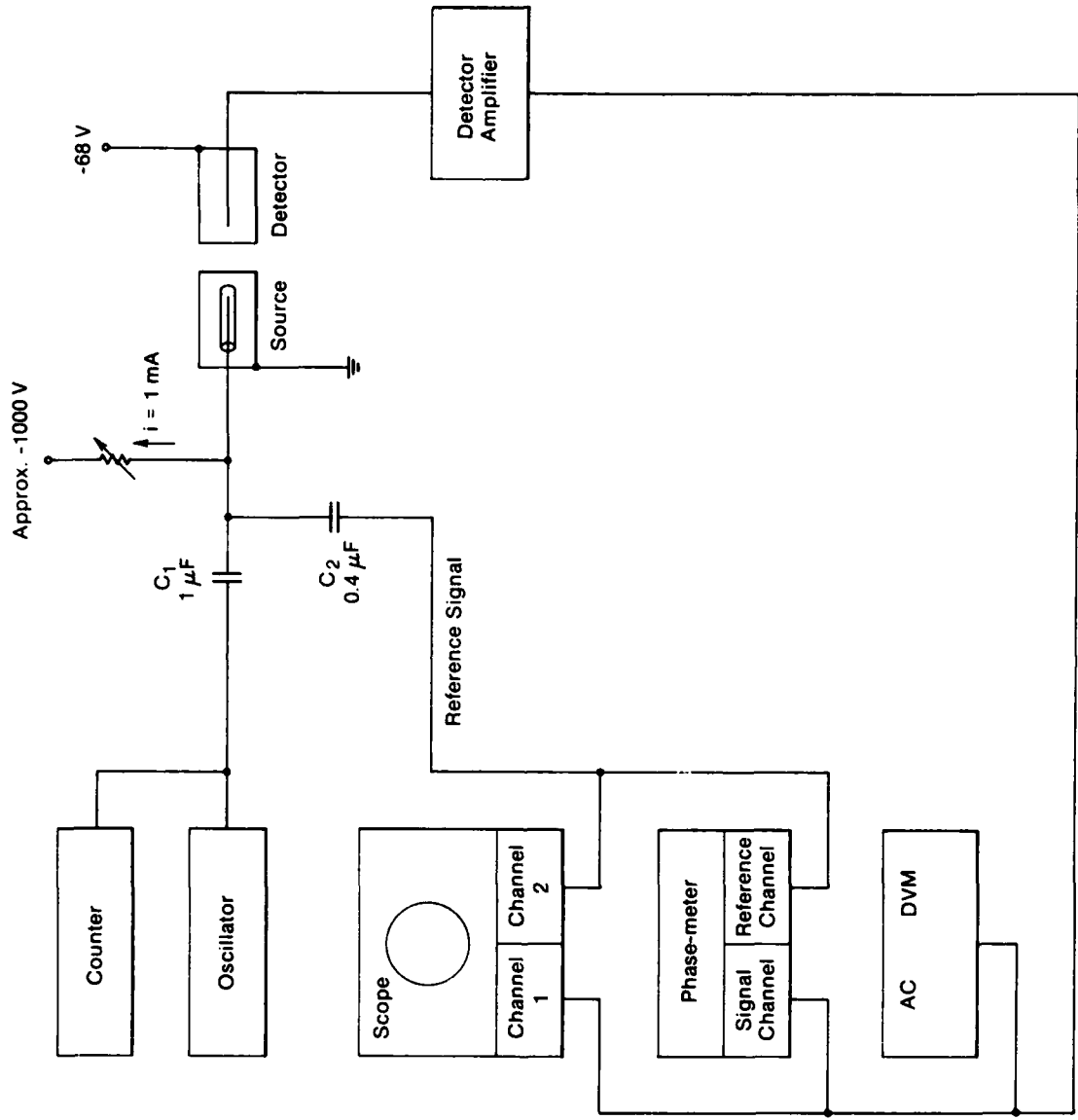

Fig. 1.--Experimental arrangement for Lyman-alpha frequency response measurements.

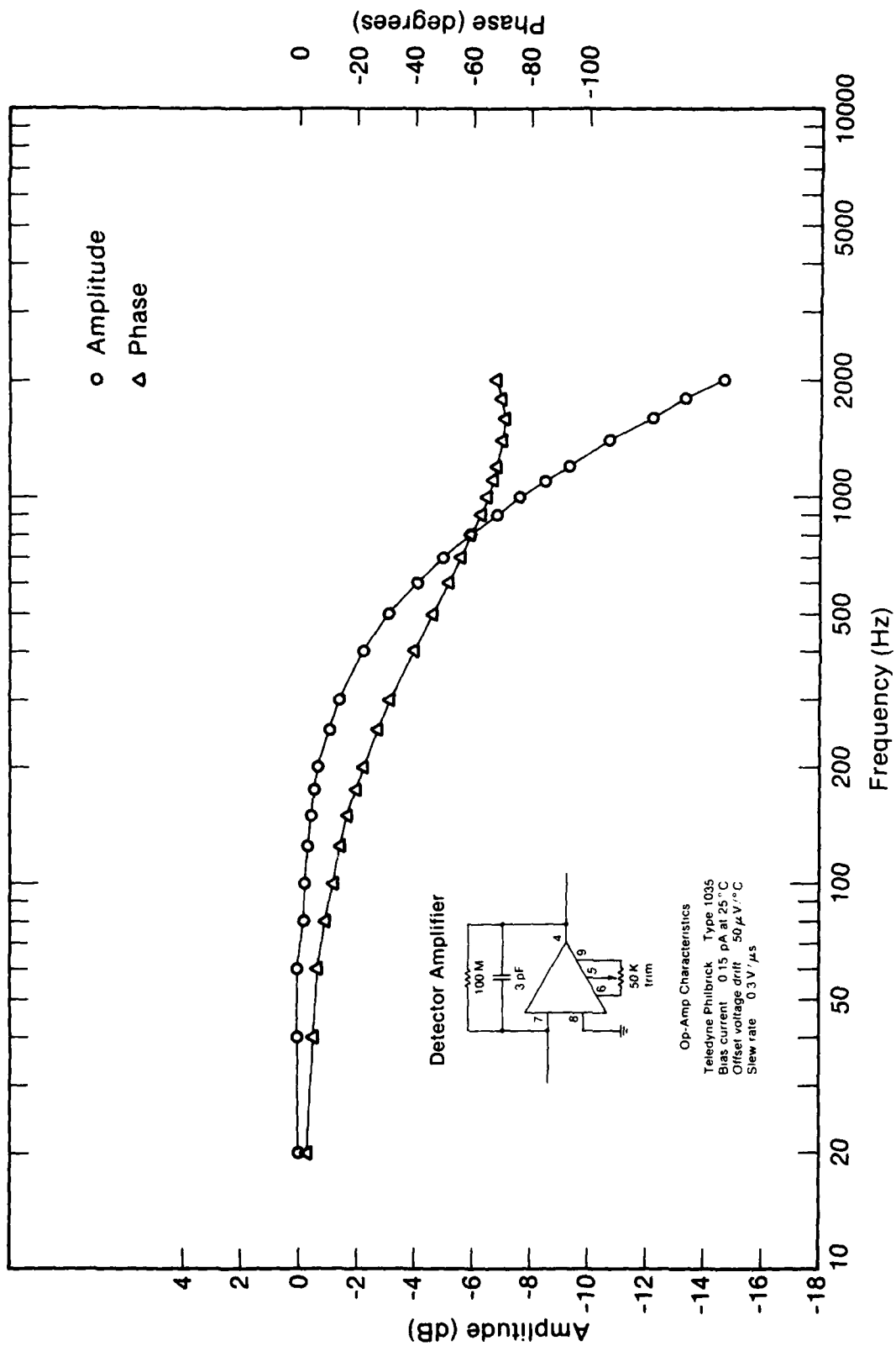

Fig. 2.--Amplitude and phase response of Kohlsiek's humidimeter.

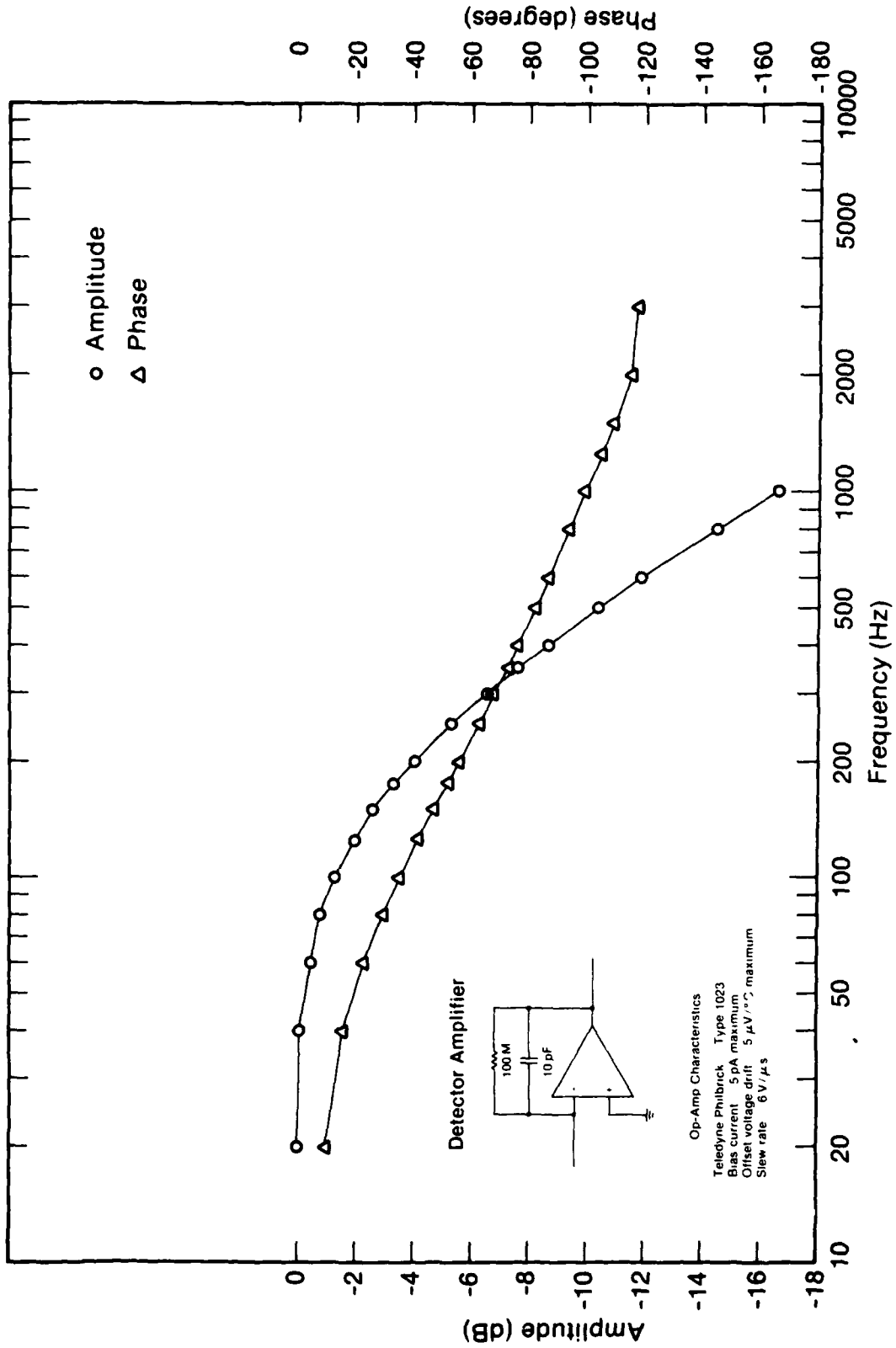

Fig. 3.--Amplitude and phase response of a model LA-3 humidimeter used by the Boulder Atmospheric Observatory.

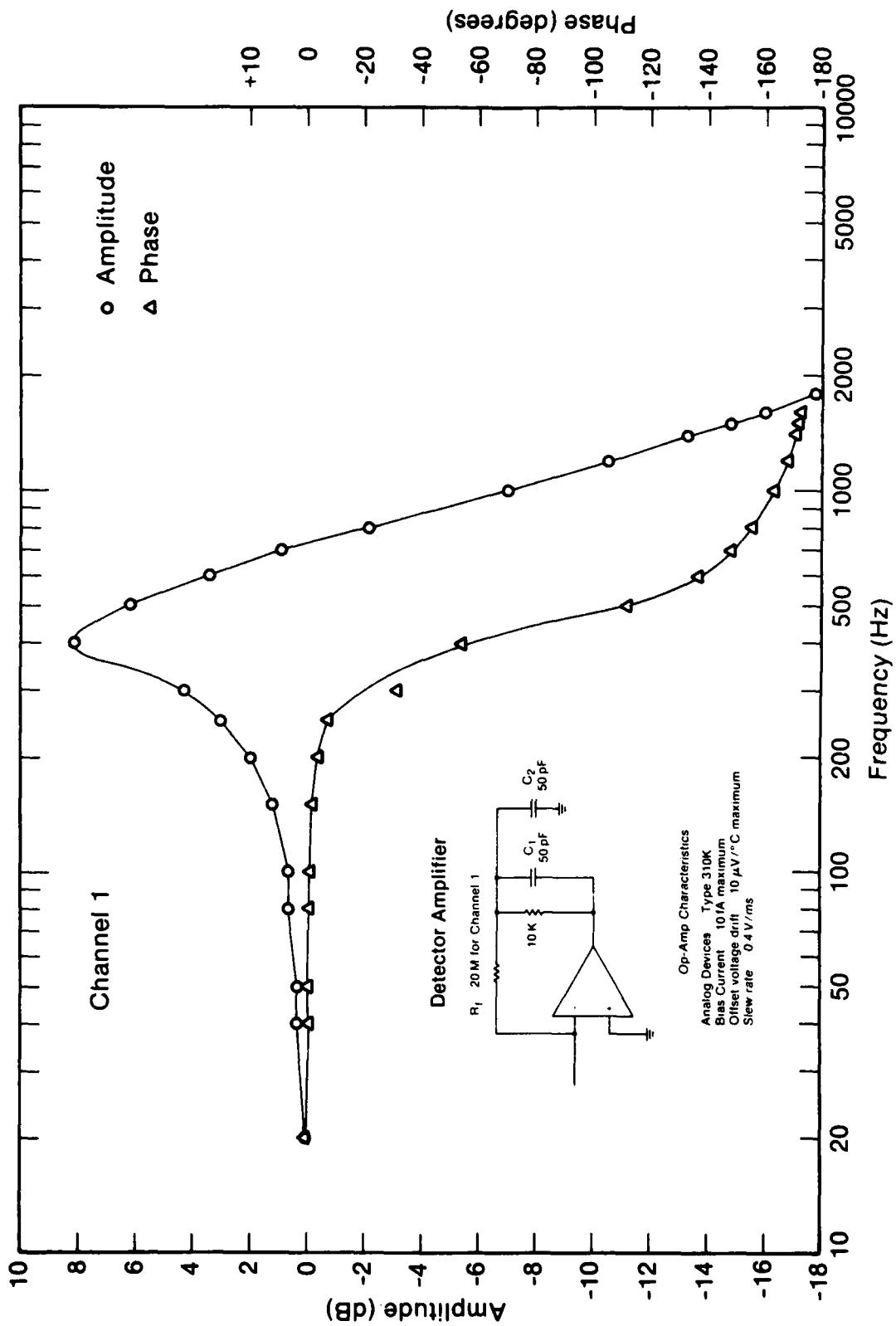

Fig. 4.--Amplitude and phase response of channel 1 of Buck's experimental humidimeter.

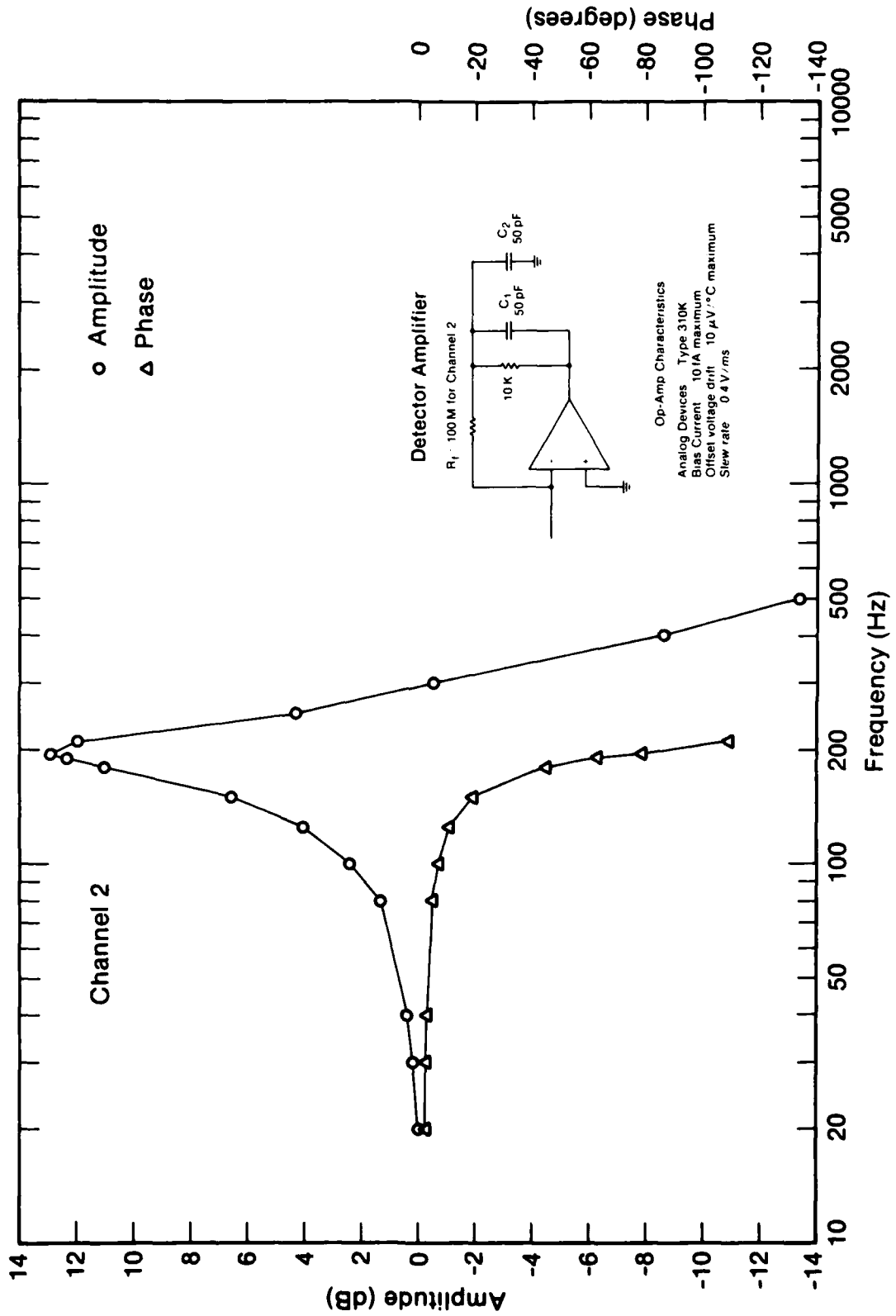

Fig. 5.--Amplitude and phase response of channel 2 of Buck's experimental humidimeter.

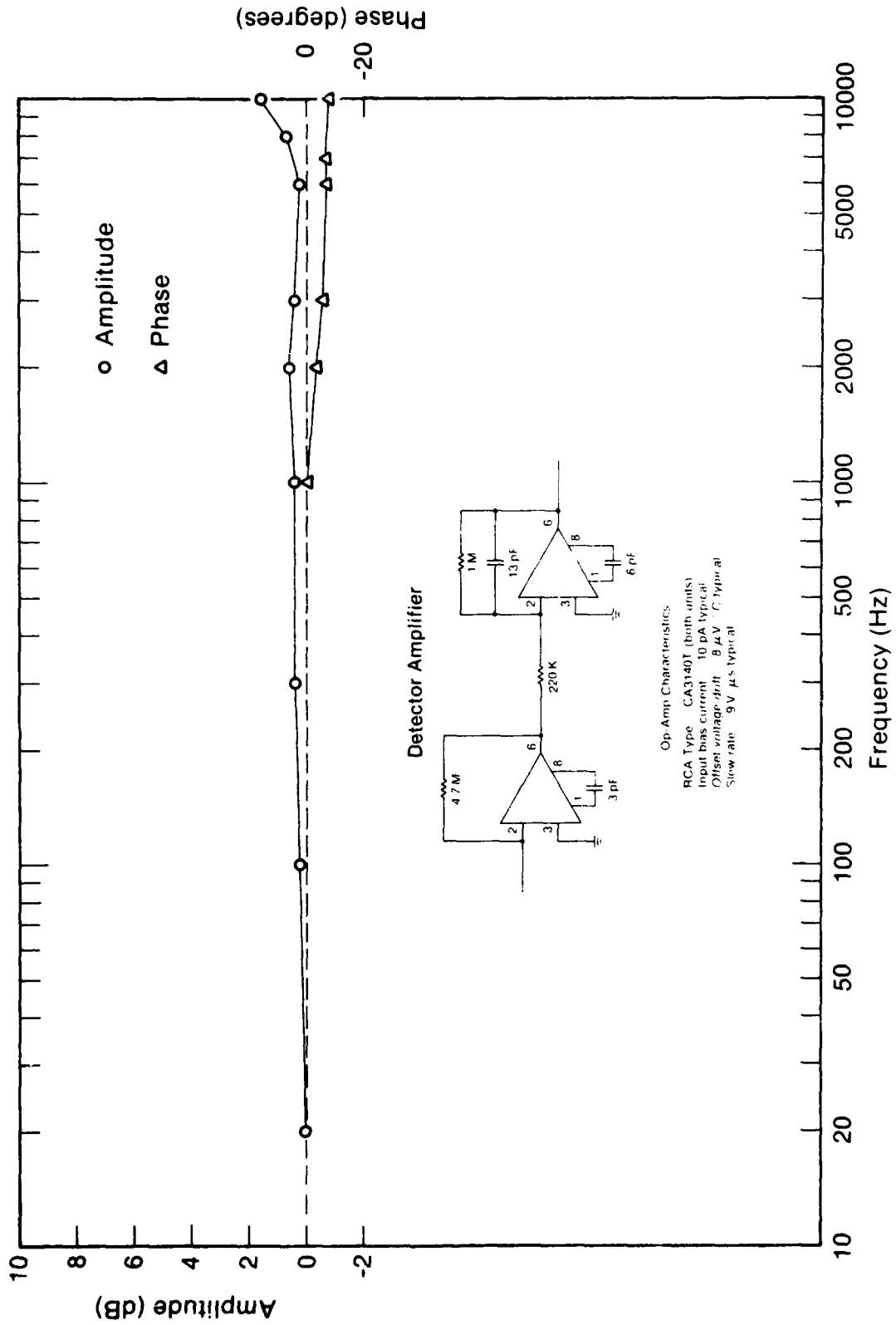

Fig. 6.--Amplitude and phase response of a humidimeter with an improved detector amplifier.

DATE
LMED
-8