

AD-A113 631

HONEYWELL ELECTRO-OPTICS OPERATIONS LEXINGTON MA
WIDE DYNAMIC RANGE FLIR.(U)
DEC 81

F/6 17/5

F33615-81-C-1493

UNCLASSIFIED

AFWAL-TR-81-1251

NL

1 OF 1
AD A
13631

END
DATE
FILMED
15-82
DTIC

12

AFWAL-TR-81-1251

WIDE DYNAMIC RANGE FLIR

HONEYWELL
Electro-Optics Operations
2 Forbes Road
Lexington, Ma 02173



December 1981

FINAL REPORT FOR PERIOD APRIL 1981 THROUGH DECEMBER 1981

APPROVED FOR PUBLIC RELEASE; DISTRIBUTION UNLIMITED

Avionics Laboratory
Air Force Wright Aeronautical Laboratories
Air Force Systems Command
Wright-Patterson Air Force Base, Ohio 45433



82 04 19 092

AD A113631

DTIC FILE COPY

NOTICE

When Government drawings, specifications, or other data are used for any purpose other than in connection with a definitely related Government procurement operation, the United States Government thereby incurs no responsibility nor any obligation whatsoever; and the fact that the Government may have formulated, furnished, or in any way supplied the said drawings, specifications, or other data, is not to be regarded by implication or otherwise as in any manner licensing the holder or any other person or corporation, or conveying any rights or permission to manufacture, use, or sell any patented invention that may in any way be related thereto.

This report has been reviewed by the Public Affairs Office (PA) and is releasable to the National Technical Information Service (NTIS). At NTIS, it will be available to the general public, including foreign nations.

This technical report has been reviewed and is approved for publication.



LEO O. VROOMBOUT, Proj Engr
Thermal Imaging Group
Mission Avionics Division
Avionics Laboratory



DR PAUL F. McMANAMON, Chief
Thermal Imaging Group
Mission Avionics Division
Avionics Laboratory

FOR THE COMMANDER

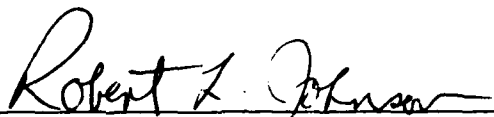

ROBERT L. JOHNSON, Maj, USAF
Deputy Chief, Electro-Optics Branch
Mission Avionics Division
Avionics Laboratory

If your address has changed, if you wish to be removed from our mailing list, or if the addressee is no longer employed by your organization, please notify AFWAL/AARI-2, Wright-Patterson AFB, OH 45433, to help maintain a current mailing list.

Copies of this report should not be returned unless return is required by security considerations, contractual obligations, or notice on a specific document.

REPORT DOCUMENTATION PAGE		READ INSTRUCTIONS BEFORE COMPLETING FORM
1. REPORT NUMBER AFWAL-TR-81-1251	2. GOVT ACCESSION NO. AD-A113 631	3. RECIPIENT'S CATALOG NUMBER
4. TITLE (and Subtitle) WIDE DYNAMIC RANGE FLIR	5. TYPE OF REPORT & PERIOD COVERED FINAL April 1981 - Dec. 1981	
	6. PERFORMING ORG. REPORT NUMBER	
7. AUTHOR(s)	8. CONTRACT OR GRANT NUMBER(s) F33615-81-C-1493	
9. PERFORMING ORGANIZATION NAME AND ADDRESS Honeywell, Inc. Electro-Optics Operations, 2 Forbes Road Lexington, MA 02173	10. PROGRAM ELEMENT, PROJECT, TASK AREA & WORK UNIT NUMBERS 27400101	
11. CONTROLLING OFFICE NAME AND ADDRESS Avionics Laboratory (AFWAL/AARI) Air Force Wright Aeronautical Laboratories Wright-Patterson AFB, OH 45433	12. REPORT DATE December 1981	
	13. NUMBER OF PAGES 46	
14. MONITORING AGENCY NAME & ADDRESS (if different from Controlling Office)	15. SECURITY CLASS. (of this report) UNCLASSIFIED	
	15a. DECLASSIFICATION/DOWNGRADING SCHEDULE	
16. DISTRIBUTION STATEMENT (of this Report) Approved for Public Release; Distribution Unlimited.		
17. DISTRIBUTION STATEMENT (of the abstract entered in Block 20, if different from Report)		
18. SUPPLEMENTARY NOTES		
19. KEY WORDS (Continue on reverse side if necessary and identify by block number) Forward Looking Infrared Set Dynamic Range Calibrated Thermal Imaging Set		
20. ABSTRACT (Continue on reverse side if necessary and identify by block number) The Avionics Laboratory Chaparral type FLIR has been modified to become a wide dynamic range (greater than 65 dB), calibrated FLIR. To accomplish this, a field stop with known temperature references was added to the optics, and the preamplifiers were replaced with new, wide dynamic range preamplifiers. These modifications as well as a few other minor modifications that were required are described. The acceptance test results are also included.		

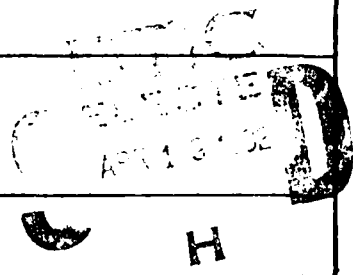

FOREWORD

The work reported here was sponsored by the Avionics Laboratory, Air Force Wright Aeronautical Laboratories. It was conducted at Honeywell Electro-Optics Operations, Lexington, MA, under contract F33615-81-C-1493.

The Air Force project monitor was Leo O. Vroombout, AFWAL/AARI-2. The contractor project manager was Jay Teich.



Accession For	
NTIS GRA&I	<input checked="" type="checkbox"/>
DTIC TAB	<input type="checkbox"/>
Unannounced	<input type="checkbox"/>
Justification	
By	
Distribution/	
Availability Codes	
Dist and/or	
Dist	Special
A	

TABLE OF CONTENTS

<u>SECTION</u>	<u>TITLE</u>	<u>PAGE</u>
1	SCOPE.	2
2	GENERAL DESCRIPTION.	3
2.1	RECEIVER	3
	2.1.1 Optical System.	3
	2.1.2 Focusing System	3
	2.1.3 Detector/Dewar Assembly	3
	2.1.4 Scanner	4
	2.1.5 Preamplifiers and Delay Lines	4
	2.1.6 Radiometric References.	4
2.2	ELECTRONICS.	6
	2.2.1 Power Distribution.	6
	2.2.2 Phase Lock and 3-Phase Generator.	6
	2.2.3 Vertical Mirror Ramp Generator.	6
	2.2.4 Sync Generator.	6
	2.2.5 Video Preprocessor.	7
	2.2.6 Video Processor	11
	2.2.7 Delay Line.	11
2.3	CONTROLS	11
	2.3.1 Power	11
	2.3.2 Gain.	12
	2.3.3 Level	12
	2.3.4 Polarity.	12
	2.3.5 Focus	12
	2.3.6 Balance	12
3	ACCEPTANCE TEST RESULTS.	13
3.1	DEWAR HOLD TIME.	13
3.2	RADIOMETRIC REFERENCES	13
3.3	WIDE RANGE OUTPUT.	14
3.4	VIDEO MONITOR OUTPUT	14
3.5	OPTICAL SYSTEM	17
	3.5.1 MTF	17
	3.5.2 MRTD.	17
3.6	EXTERNAL CLOCK INPUT	17
3.7	DETECTOR	22
3.8	FRAME INTERLACE.	22
4	CONCLUSION	26
4.1	MODIFICATIONS AND PROBLEMS ENCOUNTERED	26
4.2	USE OF THE WIDE DYNAMIC RANGE OUTPUTS.	26
	4.2.1 Radiance vs Temperature	26
	4.2.2 Emissivity.	26
	4.2.3 Objective Lens Losses	29
APPENDIX		
A	ACCEPTANCE TEST PROCEDURE FOR WIDE DYNAMIC RANGE FLIR.	30

LIST OF ILLUSTRATIONS

<u>FIGURE</u>	<u>TITLE</u>	<u>PAGE</u>
1	Redundant Detector Scheme.	5
2	Wide Range Output Video.	8
3a	Field Stop (Shown Projected Into Object Space)	9
3b	Resultant Video Waveform	9
4	Wide Range Output Timing	10
5	Wide Range Output (Channel 1).	15
6	Wide Range Output (Channel 2).	16
7	WDRF Final Test (Channel 1).	18
8	WDRF Final Test (Channel 2).	19
9	WDRF MTF Measured at RS-170 Output	20
10	Minimum Resolvable Temperature Difference.	21
11	8 to 14 μ m Detector Response	28

LIST OF TABLES

<u>TABLE</u>	<u>TITLE</u>	<u>PAGE</u>
1a	WDRF DETECTOR DATA SHEET	23
1b	WDRF DETECTOR DATA SHEET	24
1c	WDRF DETECTOR DATA SHEET	25

INTRODUCTION

The Wide Dynamic Range Forward Looking Infrared Set (WRDF) is an improved version of Honeywell's "Chaparral" type serial scan IR imaging system. These modifications permit the Avionics Laboratory FLIR to make quantitative measurements.

Specifically, the FLIR modifications are:

- Wide Dynamic Range signal processing circuits to provide outputs suitable for digitization and recording at previously infeasible temperature range/sensitivity combinations;
- a detector of smaller individual elements to improve spatial resolution and of high detectivity to improve the MRT;
- radiometric capability of the wide range outputs by the addition of two internal, servo controlled, thermal reference targets;
- a large reservoir liquid nitrogen dewar to maintain detector cooling for greater than four hours;
- an improved video processor that allows the composite TV video output to be positioned anywhere within the full 65 dB dynamic range and the sensitivity of the TV video output to be varied by a 10:1 ratio; and
- a new sync generator that provides for external clock input when desired.

At the conclusion of the WDRF Program, an approved acceptance test was carried out to characterize the Forward Looking Infrared (FLIR) and demonstrate the compliance with the tasks required. The results of these tests are included in this report.

SECTION 1
SCOPE

This report is the final technical documentation of the Wide Dynamic Range FLIR. Included are descriptions of the FLIR and results of the acceptance test.

SECTION 2 GENERAL DESCRIPTION

2.1 RECEIVER

The receiver consists of a narrow field-of-view optical system, scanning module, 18-element detector array, preamplifiers and delay lines, detector/dewar, focusing mechanism, and radiometric field stop.

2.1.1 Optical System

The receiver optics, made of germanium lenses, consists of an F/3.0 telescope. The diffraction limited telescope produces a 1.4 x 2.0 degree field-of-view.

2.1.2 Focusing System

Focus is accomplished by a germanium focal lens, driven from the control panel via a position sensitive servo control.

2.1.3 Detector/Dewar Assembly

The 18-element mercury cadmium telluride detector contains two arrays of 9 elements each. The two arrays provide alternate line outputs to compensate for the 50% duty cycle of the horizontal mirror. The serial scanning of the 9-elements and the use of the delay and add technique in the preamplifiers provides a 3:1 improvement in the signal-to-noise ratio. A cooldown sensor, mounted along side of the detector, applies bias to the detector only after the liquid nitrogen filled dewar has cooled the detector to approximately 95 K (-288°F).

2.1.4 Scanner

The scanner module houses the horizontal and vertical scanning mirrors and the collimating and detector lens assemblies. The horizontal spin mirror is a ten-faceted polygon which is directly driven by a phase-lock loop controlled motor to a speed of 47,202.7 rpm. Feedback for the phase-lock loop is by LED sender/receiver unit which produces a pulse through reflection of each side of the mirror. The vertical mirror is driven by a galvanometer at 59.94 Hz to provide a TV-compatible field rate. Vertical mirror feedback is provided by a strain gauge sensor.

2.1.5 Preamplifiers and Delay Lines

The low level signal from each element of the 18-element detector is amplified separately in the preamplifier. Referring to Figure 1, use of the serial scan technique results in a point in the scene being scanned over the 9 elements of each array at different times. This effect is taken advantage of in the tapped delay line to increase both sensitivity and signal-to-noise ratio. For a 9-element array, the sensitivity is increased by a factor of 9 and the signal-to-noise ratio is increased by a factor of 3. The output of the delay line is buffered by an emitter follower.

2.1.6 Radiometric References

A field stop assembly is located at an intermediate focal plane within the scanned optical path. In addition to limiting the optical field-of-view, the field stop contains two extended area, high emissivity, radiometric reference targets. One target rests at the local ambient temperature (elevated slightly above room temperature by scanner power dissipation), while the second is servo controlled to approximately 20 degrees above the first. The servo electronics receive feedback from two thermistors, one mounted in the middle of each target. Each target contains two additional thermistors, allowing exact temperature measurement to be made through an external connector located on the radiometric reference control box (located on the receiver assembly).

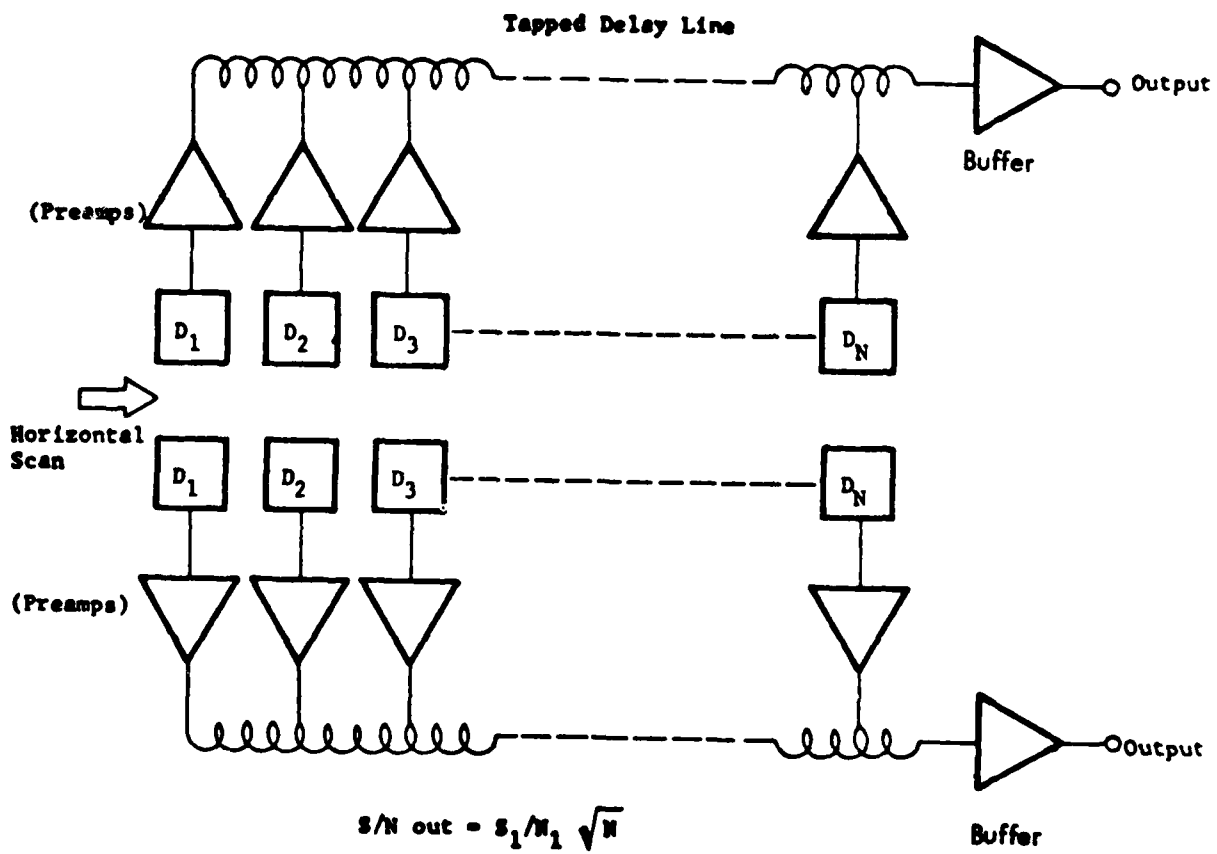

Figure 1. Redundant Detector Scheme

2.2 ELECTRONICS

The electronics assembly contains the following subassemblies:

- Power Distribution
- Vertical Mirror Driver
- Phase lock and 3-phase Generator
- Sync Generator
- Video Preprocessor
- Video Processor
- 1 H Delay Line

2.2.1 Power Distribution

The nominal voltage input is 28 Vdc with 22A peak starting current and 10A continuous current. A dc-to-dc converter, phase locked to 2H (7875 Hz square wave), supplies all necessary voltages.

2.2.2 Phase Lock and 3-Phase Generator

This subassembly controls runup of the horizontal mirror. The horizontal mirror is driven by a 3-phase induction motor. A phase lock loop controls motor speed by comparing 2H from the sync generator with feedback from the horizontal mirror inside the scanner.

2.2.3 Vertical Mirror Ramp Generator

The vertical mirror ramp generator contains the scan generation and servo electronics for the vertical mirror galvanometer drive located in the receiver. Vertical drive from the sync generator synchronizes the start of the vertical ramp scan. Scan servo feedback is obtained from the vertical position sensor on the scan mirror.

2.2.4 Sync Generator

This circuit, provides the basic signals required to generate a composite video waveform for a 525 line, 60 Hz field rate, 30 Hz frame rate 2:1

interlaced television system as defined by the EIA (Electronic Industries Association) standard RS-170. The clock frequency for this circuit is a 2.04545 MHz, obtained from a crystal oscillator. The sync generator may be driven by an external clock when this function is enabled.

2.2.5 Video Preprocessor

The video preprocessor performs all signal processing for the wide range outputs and preliminary signal processing of the video for the video processor.

The wide range outputs supply two independent channels of video after limited processing. Each signal contains scene, cold reference target, hot reference target, and some superfluous information. These signals are dc-restored so that the cold reference target level is clamped to -3.5 to -3.75 V and are gain corrected to approximately 3.6 mV/C. This allows the wide range outputs to display temperatures from 50°C below ambient to 250°C above ambient. A sample of the wide range signal is shown in Figure 2.

Two TTL level signals are provided at connector J3 on the electronics assembly for synchronization of an external digitizer. Since scene video occurs at half the normal television rate, a square wave at 7875 Hz (2H) is output for horizontal timing. Vertical Drive is also output for vertical timing. Figures 3 and 4 show the location of cold references (TL) on each channel, as well as hot references (TH) and active scene video. A 2 μ s sample is recommended for capturing cold and hot references.

Additional processing of the video signal is necessary to clip out a portion of the signal for the video processor and display on a monitor. First, two artificial reference voltages, used by the video processor in a similar manner as the field stop references must be inserted into the video. The level of the inserted voltage is set from the control panel. After the video is buffered, it is clipped so as not to saturate the video processor. The dc offset of the clipping circuit follows the level of the artificial reference

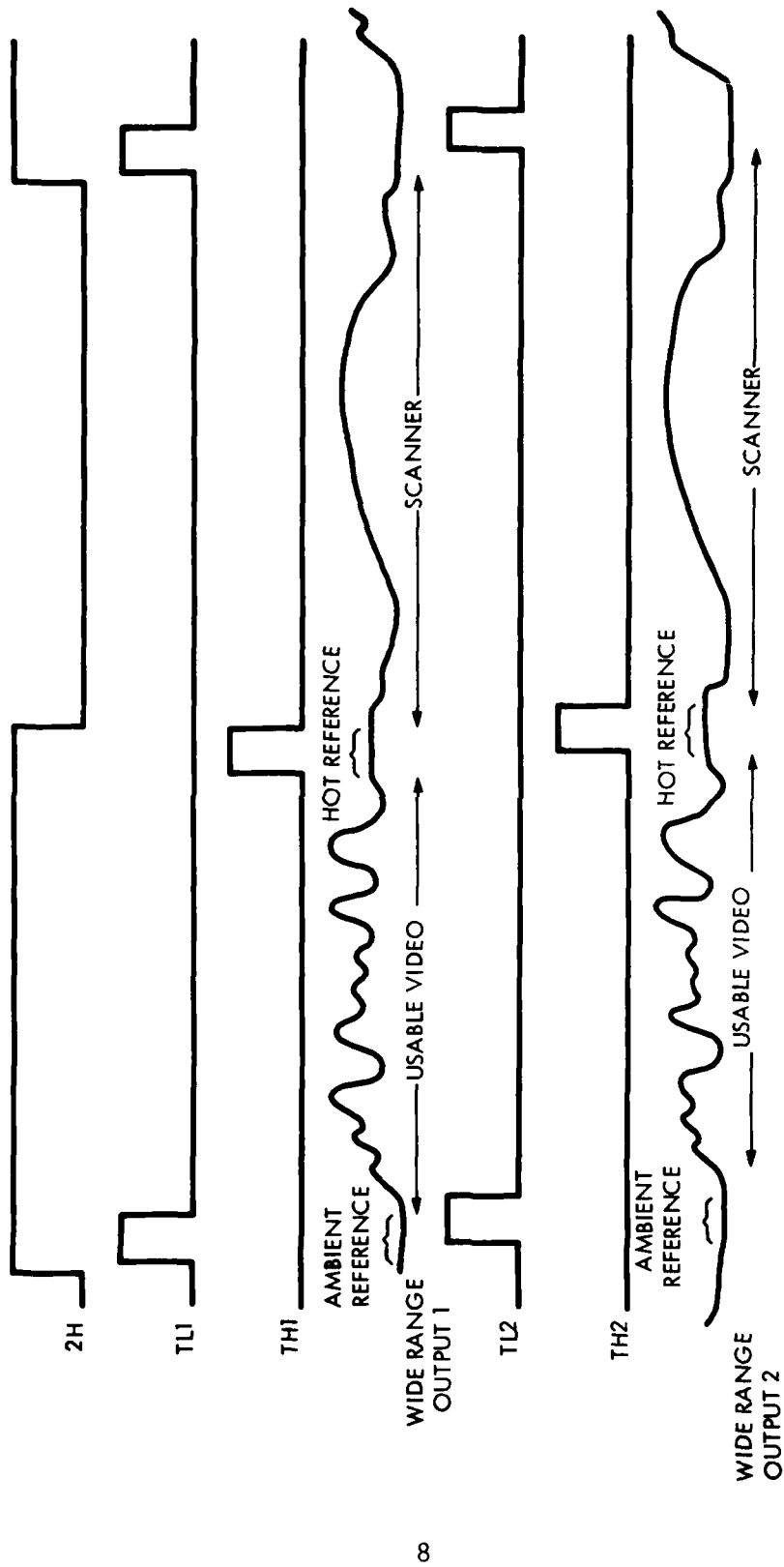

Figure 2. Wide Range Output Video

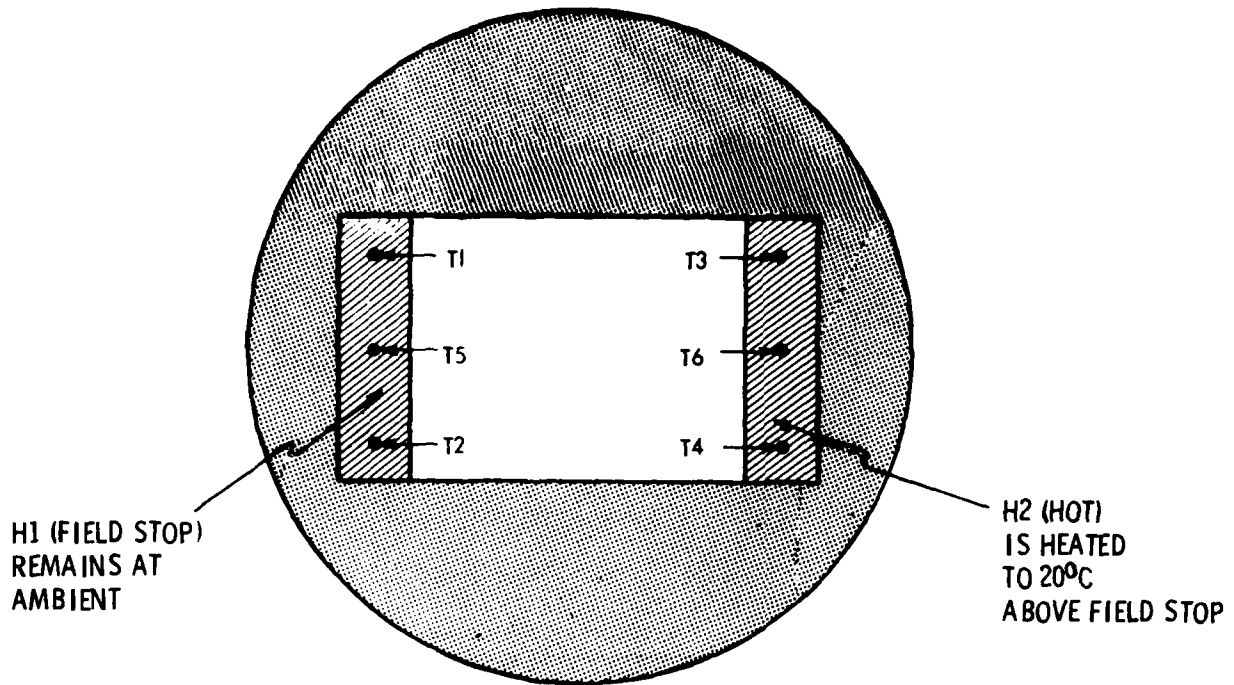

Figure 3a. Field Stop (Shown Projected Into Object Space)

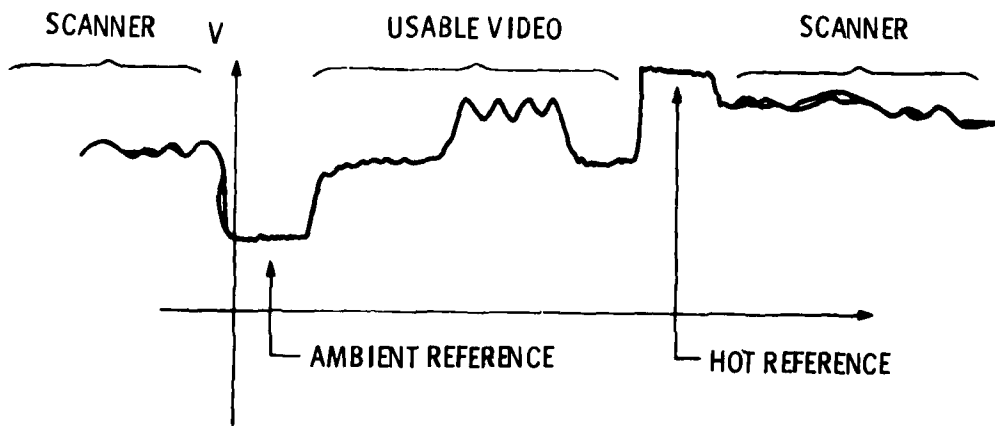

Figure 3b. Resultant Video Waveform

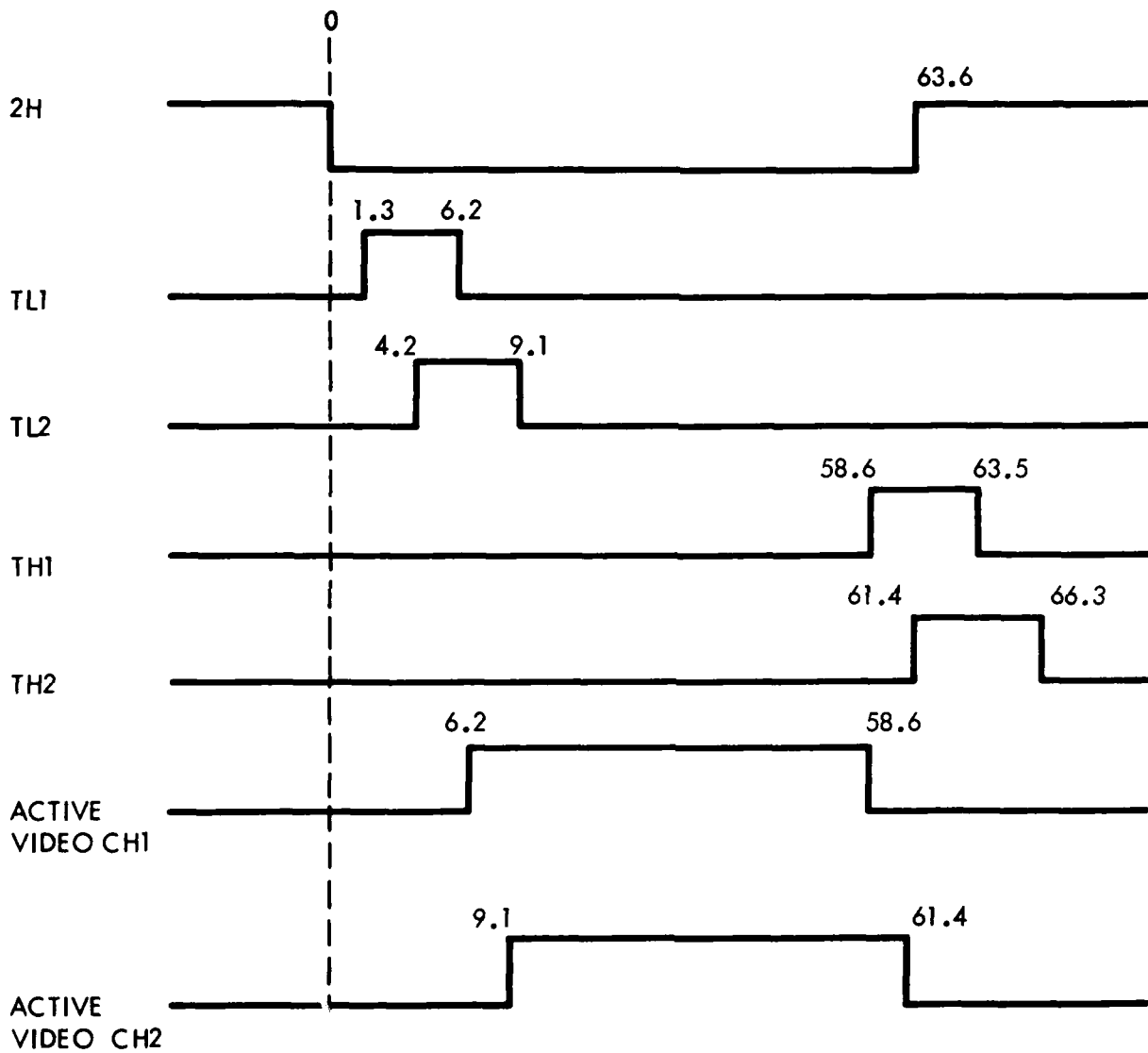

Figure 4. Wide Range Output Timing

voltages. In this way, only the desired portion of the wide dynamic range video is passed through to the video processor. To correct any level error caused by shading of the detectors (a problem aggravated by the extreme level offset range), a balance signal is fed to the video preprocessor from the control panel to adjust the artificial references of channel two.

2.2.6 Video Processor

The video processor automatically controls the gain of channel 1 and 2 video inputs from the preprocessor according to the setting of the gain control on the control panel. Channel 2 video is sent to the delay line, delayed, returned to the video processor and multiplexed with the channel 1 video into a single video channel. Horizontal and vertical synchronization pulses are added to the video to produce a composite video signal compatible with the television video display monitor. The video may be displayed as WHITE equals HOT or WHITE equals COLD by operator command.

2.2.7 Delay Line

The Delay Line is a standard TV studio unit, analog module, mounted on a printed circuit card to form the delay line. It provides a delay of one horizontal line time (60.520 μ s) permitting channel 1 and channel 2 to be swept simultaneously on two horizontal lines. Channel 2 is delayed one horizontal scan time so that channel 1 may sweep across the CRT return and sweep the next line with channel 2 sweeping at the same time the next alternate line. The delay line also has an adjustable gain sufficient to overcome impedance matching and insertion losses so that channels 1 and 2 net gain may be matched in the video processor.

2.3 CONTROLS

2.3.1 Power

This switch applies 28 V to the system electronics. The system should be in operation not later than six minutes after power is applied. This

period allows time for the horizontal and vertical mirrors to reach operating speed.

2.3.2 **Gain**

This control varies video gain to vary thermal sensitivity. Fully CCW rotation sets a display range of 100°C. CW rotation decreases the display range (increased gain) to 10°C. Display range is a window centered about a level determined by the level control setting.

2.3.3 **Level**

This control selects the portion of the dynamic range to be displayed on video monitor. Clockwise rotation increases the center temperature of the display range window.

2.3.4 **Polarity**

This switch provides white/hot or black/hot video to the video monitor.

2.3.5 **Focus**

This control adjusts the proper focus.

2.3.6 **Balance**

This control, located on the left side of the control box, allows minor adjustment of the channel balance to improve the uniformity of the image when viewing extremely hot or cold objects with a large thermal offset selected.

SECTION 3 ACCEPTANCE TEST RESULTS

All testing was conducted at standard laboratory conditions. Room temperature was 23°C. A copy of the Acceptance Test Procedure is included in the appendix.

3.1 DEWAR HOLD TIME

The dewar was filled at 0950 hours and covered. An active video signal was maintained through 1425 hours giving a hold time of 4 hours and 35 minutes.

3.2 RADIOMETRIC REFERENCES

A 2.5 Vdc source was applied to the thermistors using the thermistor control box supplied as an accessory to the WDRF and an adjustable power supply. Voltages were read using a DVM. Reference temperatures can be calculated using the following equation:

$$T = \frac{E \text{ out} - 0.65107 E \text{ in}}{-0.0067966 E \text{ in}}$$

For $E \text{ in} = 2.5 \text{ Vdc}$

$$T = \frac{E \text{ out} - 1.62768}{-0.0169915}$$

The voltages measured and corresponding temperatures are:

T1	1.087 V	--31.8°C
T2	1.089 V	--31.7°C
T3	0.739 V	--52.3°C
T4	0.751 V	--51.6°C

The wide range outputs were displayed on an oscilloscope verifying the presence of the radiometric references in the video waveform.

3.3 WIDE RANGE OUTPUT

With vertical and horizontal mirrors disabled, the NEAN was measured at both preamp outputs. Using a Ballentine RMS meter, the measured voltages were 370 μ V and 415 μ V for channel one and two respectively. These measurements do not reflect the true noise due to spurious noise from the dc-to-dc converter and fan driver which occur only at video dead times. A more accurate measurement can be made using the Gaussian overlap method.⁽¹⁾ Using this method, the noise was measured at both the preamp and wide range outputs. Measurements were made only during the active video. The noise measurements were:

Channel 1 preamp - 210 μ V
Channel 2 preamp - 220 μ V
Channel 1 wide range output - 1.25 mV
Channel 2 wide range output - 1.4 mV

Using these noise measurements for reference of the dynamic range of the wide range outputs, Figures 5 and 6 show dynamic range in excess of 70 dB.

3.4 VIDEO MONITOR OUTPUT

The video output was displayed on an oscilloscope in order to show EIA RS170 compatibility. A blackbody source at a temperature greater than 250°C above ambient was displayed on a monitor without saturation, demonstrating positive offset. Negative offset was demonstrated to 25°C below ambient using an ice bath. Additional negative offset was estimated to include 50°C below ambient. Varying the gain control during testing demonstrated a display range of 10°C to 100°C.

(1) Gary Franklin and Troy Hatley, "Don't Eyeball Noise;" Electronic Design 24; November 22, 1973; pp. 184-187.

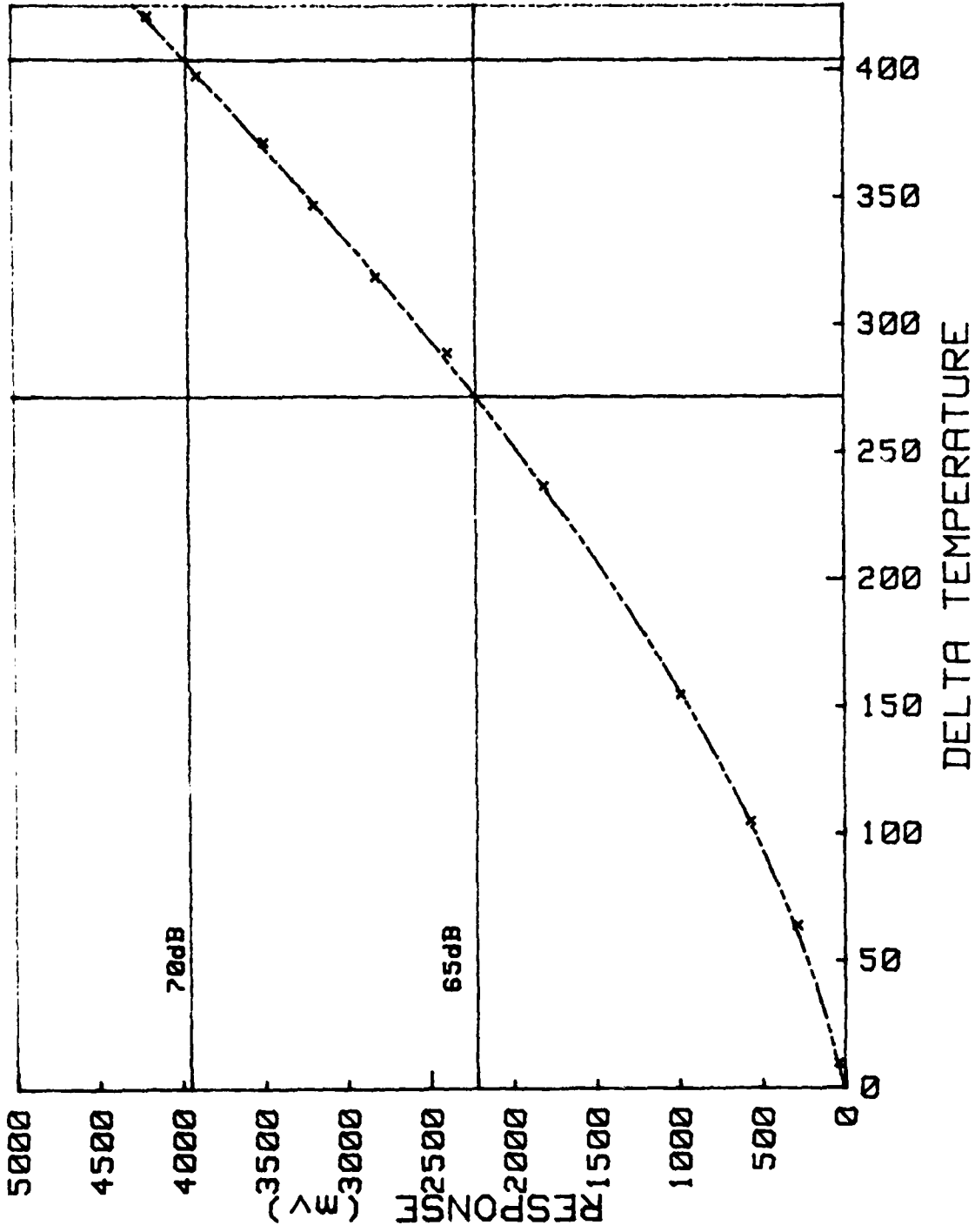

Figure 5. Wide Range Output (Channel 1)

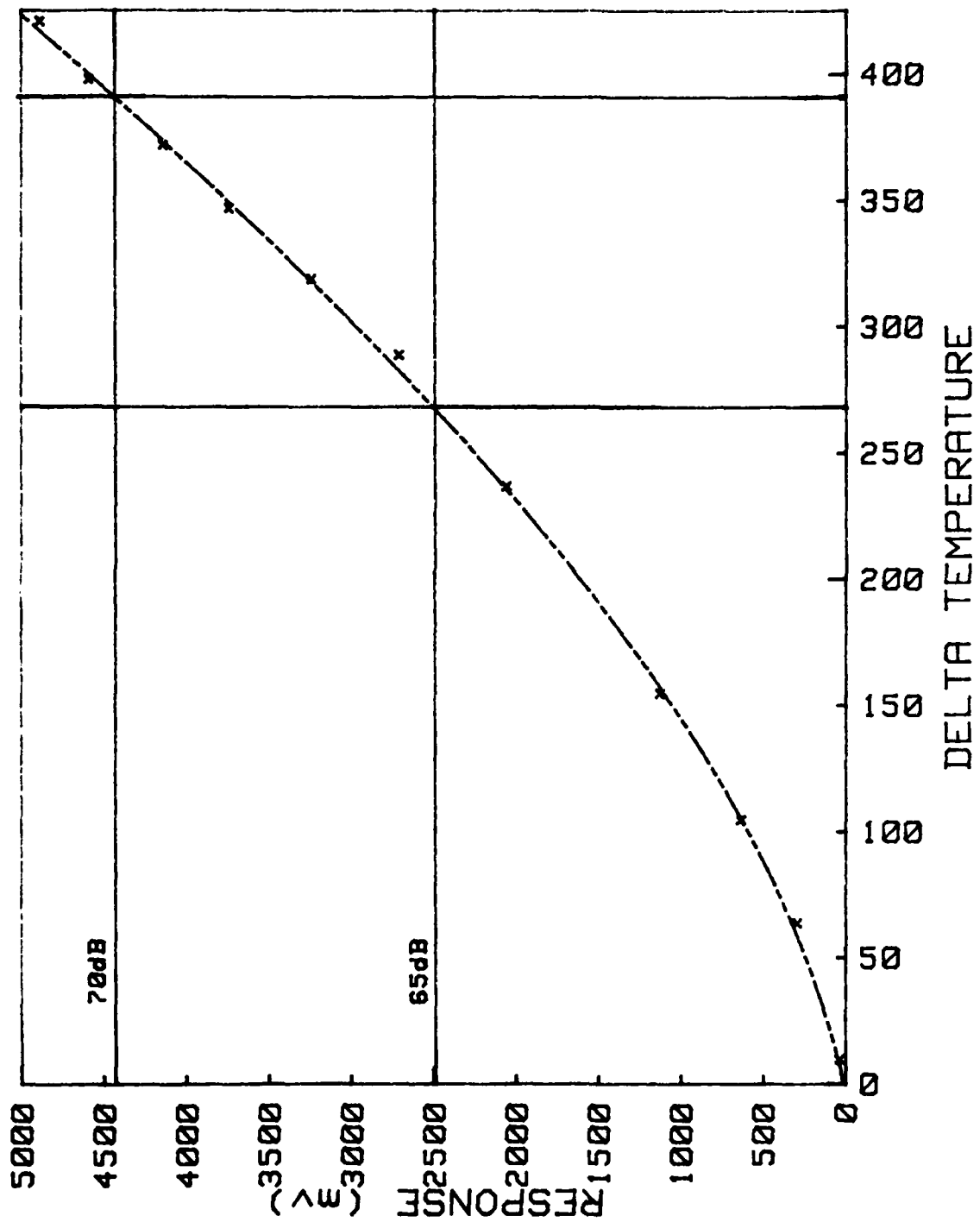

Figure 6. Wide Range Output (Channel 2)

3.5 OPTICAL SYSTEM

MTF and MRT measurements were made to qualify current system performance.

3.5.1 MTF

The MTF measurements were made using a 10°C blackbody source. Bar targets of 0.5 to 7 cy/mr were inserted in front of the blackbody source and peak-to-peak modulation produced, referenced to a large (dc) target, was measured and converted to percent MTF. These measurements were made at the wide range outputs where there is no high frequency peaking in the electronics. This results in a lower response at higher spatial frequencies than would have been measured at the video monitor output. The data for channels one and two are plotted in Figures 7 and 8. MTF measurements taken at the video monitor output are plotted for reference in Figure 9.

3.5.2 MRTD

MRTD measurements were made using a fixed 3°C delta T blackbody and targets of varying spatial frequency. Attenuators were inserted and removed as necessary to simulate effective temperature differences of less than the fixed blackbody source. The observers adjusted monitor and system controls to aid in detection of the targets.

Observers: L. Vroombout AFWAL
R. Cranos AFWAL
P. Wourms AFWAL

A plot of the data is shown in Figure 10.

3.6 EXTERNAL CLOCK INPUT

An external clock with a frequency of 2.04545 MHz with a voltage swing of ± 5 V was used as the system clock. The video output was observed on

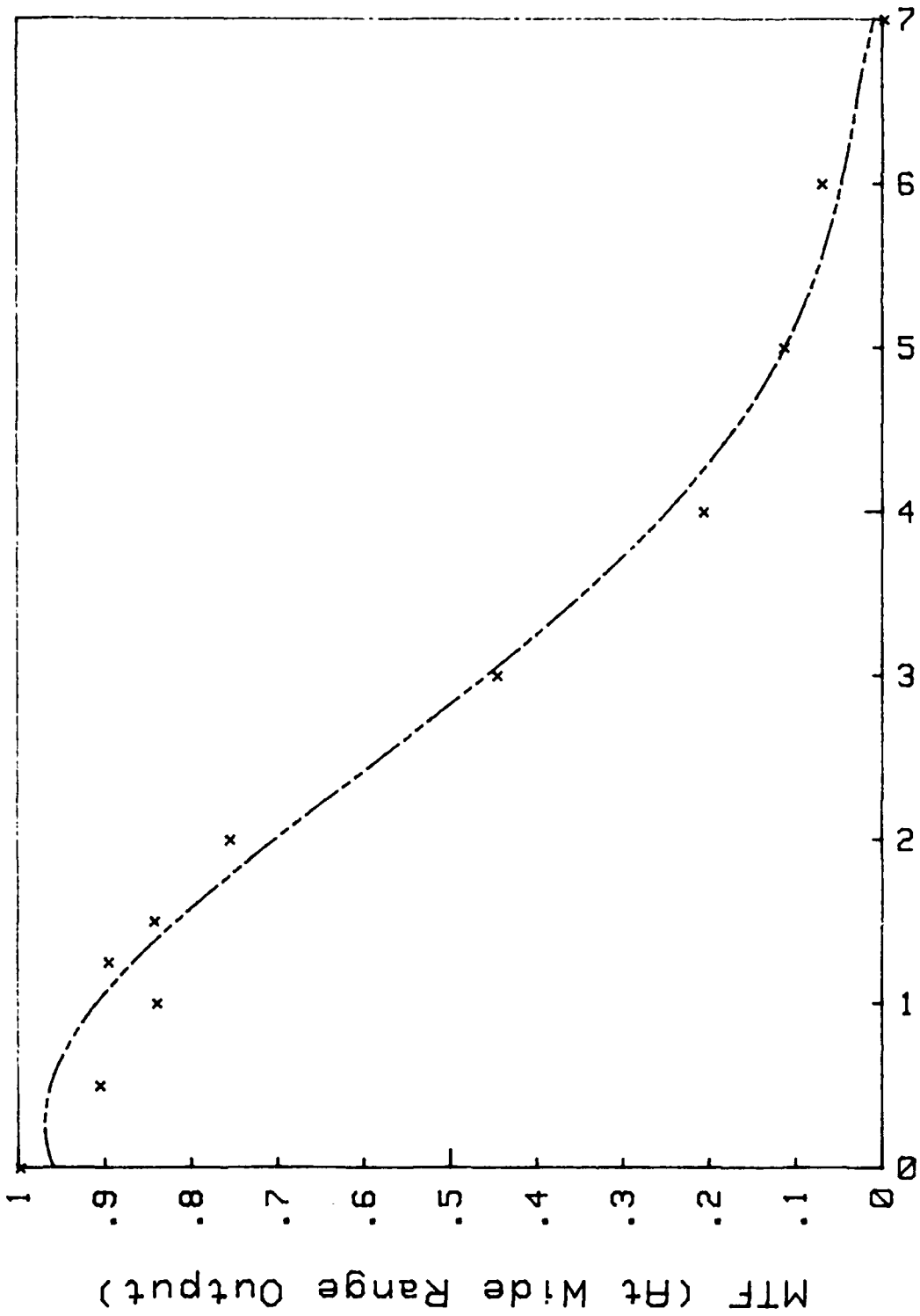

Figure 7. WDRF Final Test (Channel 1)

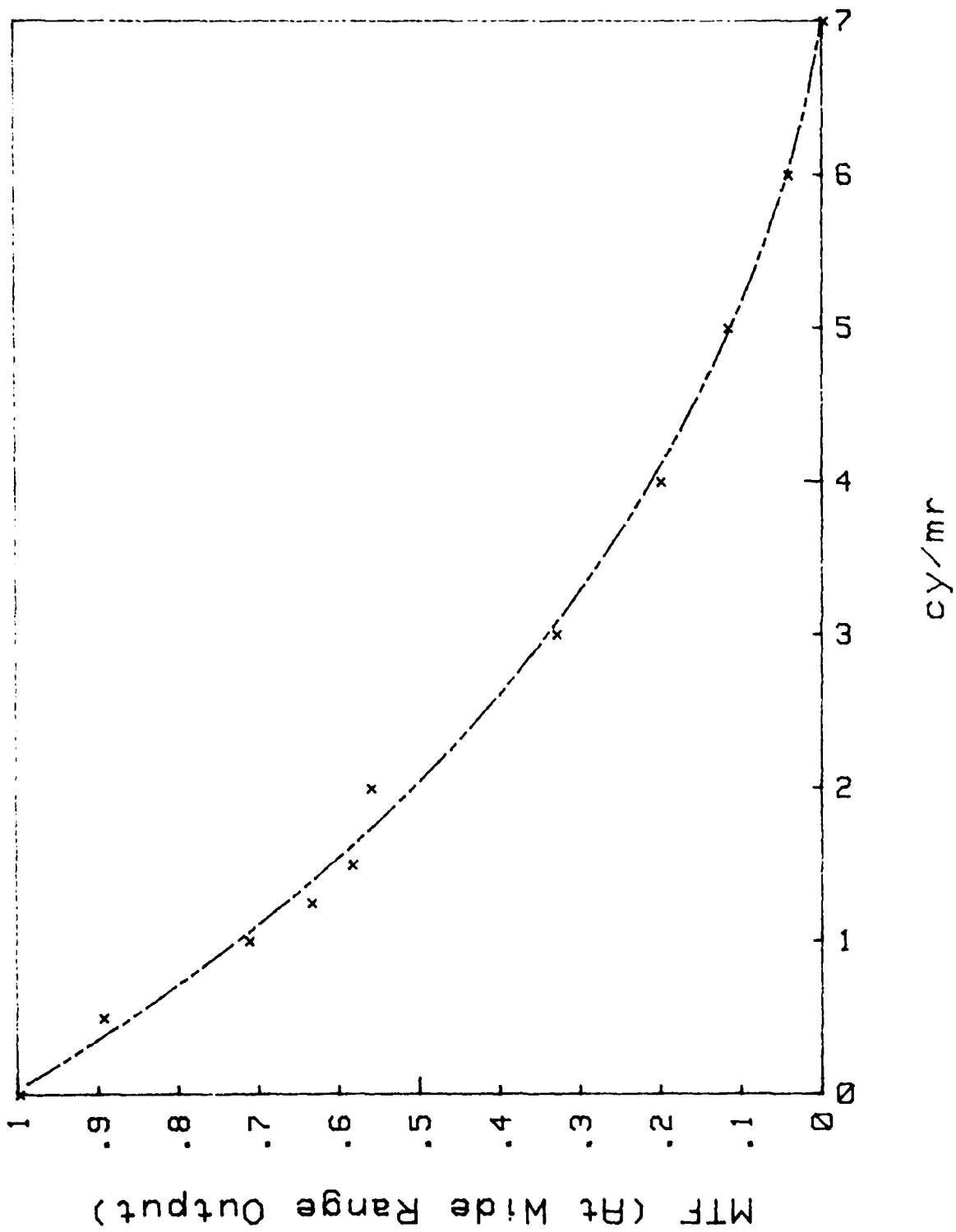
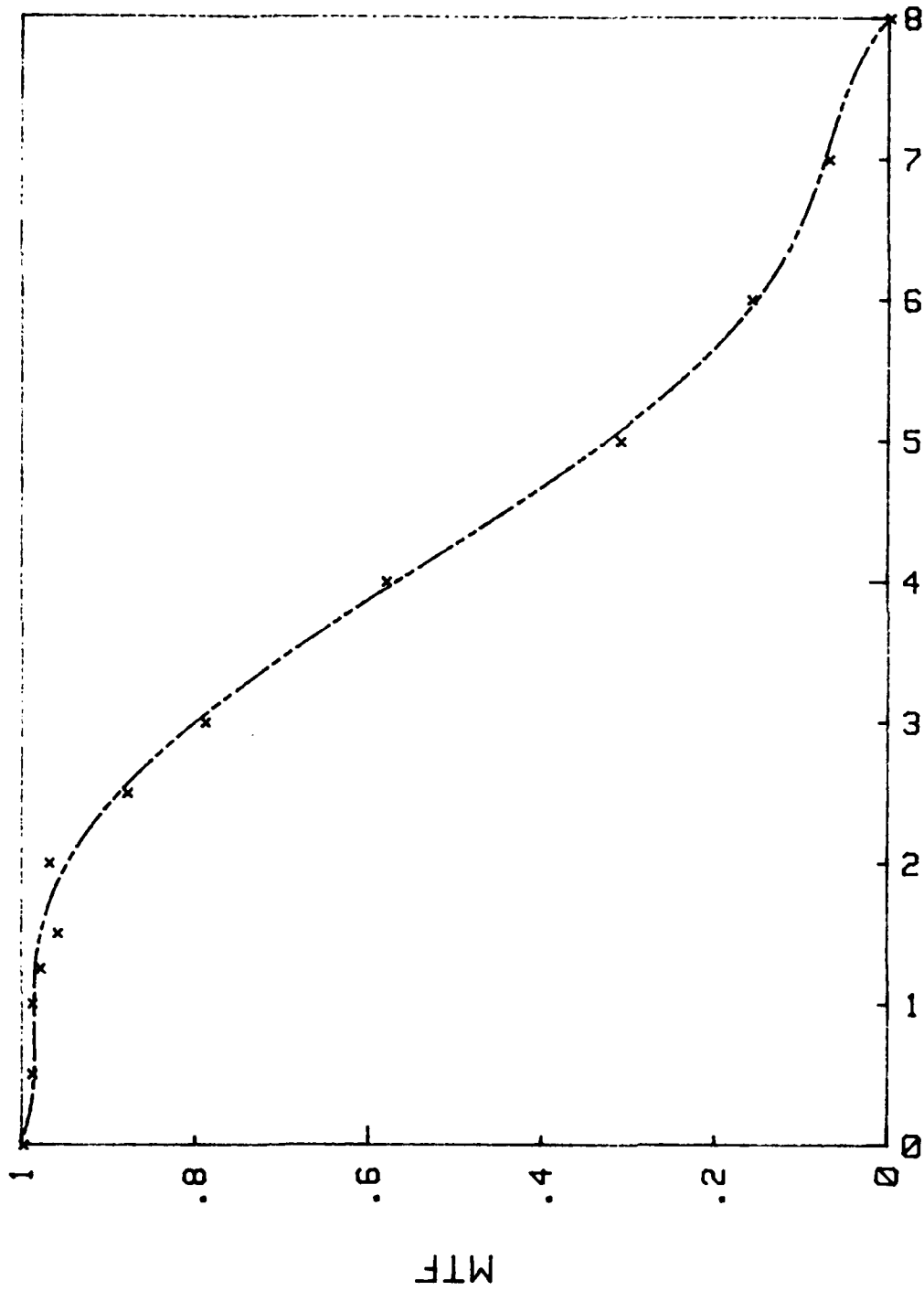

Figure 8. WDRF Final Test (Channel 2)



Spatial Frequency (cy/mr)

Figure 9. WDRF MTF Measured at RS-170 Output

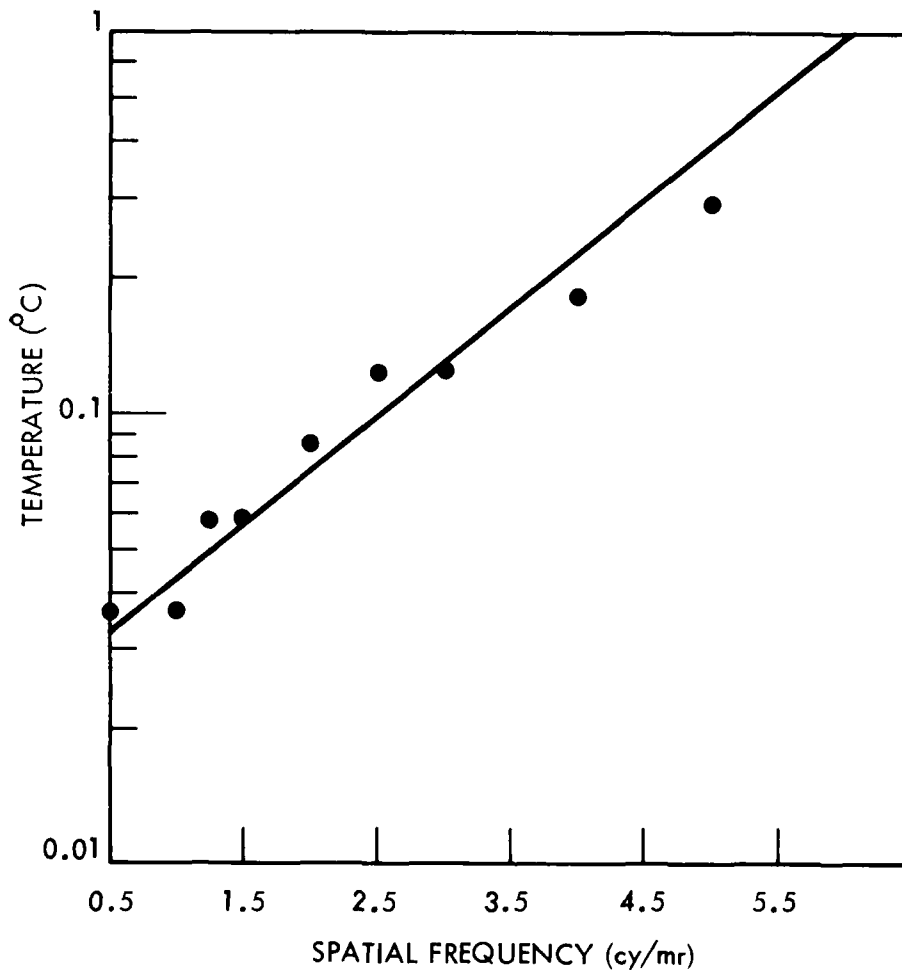

Figure 10. Minimum Resolvable Temperature Difference

an oscilloscope to be EIA RS 170 compatible. While displaying the external clock and composite video on an oscilloscope it was seen that varying the external clock caused the composite video waveforms timing to vary in synchronism.

3.7 DETECTOR

Original detector measurements, as shown in Table 1c, indicate the average D^* and responsivity exceeding the specifications. A dewar repair made it necessary to bake the detector, resulting in some degradation in performance.

Final detector measurements were made at two different biasing currents. While detector D^* was 10% lower than specified, an additional decrease of bias current would increase D^* with some loss of responsivity. System tests using a bias current of 2.5 mA show MRTD and MTF are much improved from the original system. Detector data is in Tables 1a and 1b.

3.8 FRAME INTERLACE

The output video was displayed on an oscilloscope while one detector channel was disabled showing one channel was sufficient to scan all points in the field-of-view.

Table 1a. WDRF DETECTOR DATA SHEET

Element No.	300 K Ω	OP Ω	BIAS		$D*bb \times 10^{10}$		Resp $V/W \times 10^3$	1 mA Ω	-3 dB τ
			I mA	E mV	1 kHz	10 kHz			
1	39.5		3.0	460	2.02	2.18	202	128	2.75 58 ns
2	38.1		3.0	425	1.49	2.28	166	118	3.0 53
3	39.3		3.0	444	1.73	2.24	191	125	3.0 53
4	38.0		3.0	440	2.08	2.35	195	123	3.0 53
5	38.1		3.0	410	1.74	2.06	171	118	2.5 64
6	36.5		3.0	327	1.18	1.31	97	113	2.2 72
7	36.6		3.0	440	1.99	2.10	192	125	2.75 58
8	44.3		DEAD					101	
9	37.3		3.0	410	2.29	2.50	177	114	3.0 53
10	38.9		3.0	508	2.06	2.69	235	135	2.75 58
11	37.4		3.0	371	2.54	2.78	176	99	2.25 71
12	37.0		3.0	374	2.63	2.81	176	100	2.25 71
13	37.4		3.0	447	2.68	2.83	215	120	2.5 64
14	37.4		3.0	413	2.22	2.65	209	107	1.75 91
15	36.8		3.0	453	2.70	2.88	222	119	2.75 58
16	36.2		3.0	448	2.53	2.68	222	119	2.5 64
17	36.5		3.0	428	2.54	2.70	211	115	2.5 64
18	35.9		3.0	421	2.22	2.64	207	111	2.5 64

NOTE: Blackbody to peak spectral conversion factor = 1.95

Table 1b. WDRF DETECTOR DATA SHEET (Continued)

Element No.	300 K Ω	OP Ω	BIAS		$D^{*bb} \times 10^{10}$		Resp $V/W \times 10^3$	1 mA Ω	-3 dB τ
			I mA	E mV	1 kHz	10 kHz			
1			2.5	369	2.20	2.36	207		2.25 71 ns
2			2.5	341	1.99	2.46	167		2.5 64
3			2.5	357	2.07	2.44	193		2.5 64
4			2.5	354	2.42	2.56	197		2.75 58
5			2.5	331	2.00	2.24	171		2.25 71
6			2.5	274	1.33	1.43	94		1.8 88
7			2.5	355	2.23	2.27	195		2.4 66
8									
9			2.5	327	2.44	2.66	175		2.5 64
10			2.5	405	2.33	2.81	238		2.75 58
11			2.5	294	2.66	2.82	174		2.0 80
12			2.5	296	2.76	2.83	175		1.9 84
13			2.5	356	2.82	2.90	216		2.25 71
14			2.5	327	2.41	2.72	213		1.6 99
15			2.5	360	2.82	2.96	228		2.5 64
16			2.5	357	2.67	2.80	228		2.25 71
17			2.5	341	2.66	2.80	215		2.25 71
18	2.5	334	→		2.46	2.75	210		2.1 76

NOTE: Blackbody to peak spectral conversion factor = 1.95

Table 1c. WDRF DETECTOR DATA SHEET (Continued)

Element No.	300 K Ω	OP Ω	BIAS		$D^{*bb} \times 10^{10}$		Resp V/W $\times 10^3$	1 mA Ω	-3 dB τ
			I mA	E mV	1 kHz	10 kHz			
1	38.6		3	447		3.02	244	118	2.5 53
2	37.5		3	406		3.04	200	109	3.0 53
3	38.8		3	420		3.12	237	111	2.5 63
4	37.4		3	416		2.92	229	112	2.75 58
5	36.1		3	380		2.92	209	100	2.75 58
6	36.0		3	344		1.97	145	100	2.78 58 1.45 Resp.
7	36.2		3	432		3.08	245	113	2.5 63
8	43.9		DEAD					112	
9	35.4		3	374		3.23	218	100	2.5 63
10	37.9		3	468		3.14	265	120	2.5 63
11	36.7		3	352		3.13	191	93	2.0 79.5
12	36.2		3	356		3.01	184	96	2.5 63
13	36.6		3	420		3.14	222	112	3.0 53
14	36.7		3	395		2.88	228	102	1.75 90
15	36.1		3	429		3.12	235	113	2.75 58
16	35.6		3	421		3.06	242	111	2.5 63
17	35.8		3	411		2.90	226	110	2.75 58
18	35.4		3	404		3.11	228	105	2.5 63 ns

NOTE: Blackbody to peak spectral conversion factor = 1.95

SECTION 4 CONCLUSION

4.1 MODIFICATIONS AND PROBLEMS ENCOUNTERED

The Wide Dynamic Range FLIR, a thermal imaging system, was modified according to contract number F33615-81-C-1493 to provide a calibrated, wide dynamic range output, in a format suitable for a digital recording system. A new detector-dewar was fabricated with better resolution and greater detectivity than that of the original detector-dewar. During system modifications it became evident that the new dewar was losing vacuum. After testing by the detector lab at Honeywell, it was determined that the leak was at a metal glass bond and was repairable. The detector's specifications were slightly degraded by the necessity of baking the detector during repair. The detector-dewar was in use several weeks after repair without further problems. The original delay and add preamplifiers were limited in their dynamic range, so they were replaced with modified preamps from Honeywell's AN/APQ-9(XA-2) FLIR. A new video preprocessor board also contains circuitry to select a portion of the wide dynamic range video to be processed by a modified second video processor board. The second video processor board combines the two channels of video and formats them for standard RS-170 output. Problems encountered with the video processors included channel balancing of the two video channels. The original approach to the problem was a feedback system that attempted to match the average dc voltage of each video channel. This method had large errors when the scene being viewed was mostly background with a small target with a large delta temperature. Therefore a user adjustment was added to balance the video channels. It was found to be quite easy to adjust the balance control to an optimal setting when viewing a monitor. The large number of timing signals required from the sync generator required major modifications of the existing board. To reduce risks and delays it was decided to replace the sync board with a copy of an existing sync board that uses a PROM to generate the numerous timing signals required. The use of a PROM made adjustments of timing signals,

when necessary, very easy. The addition of a field stop, with temperature references, permit calibration of the wide dynamic range outputs. New electronics were added to control the temperature references and to provide the user with a means of determining the temperature of the references (the two temperature references have a fixed delta between them but float with ambient temperature).

4.2 USE OF THE WIDE DYNAMIC RANGE OUTPUTS

The inclusion of radiometric reference targets within the WDRF scanned field-of-view allows the system to perform as an imaging radiometer. This section contains a brief discussion of some considerations that must be made when performing radiometric measurements.

4.2.1 Radiance vs Temperature

The WDRF is sensitive to spectral radiant emission in the 8 to 14 μm region. Although the value of this detected energy from an object is determined by the object's temperature with a predictable relationship, it is not a linear relationship. Planck's equation may be used to calculate this relationship precisely (approximately a T function) knowing exact spectral response. However, an empirical determination of the system's temperature to voltage relationship is a much simpler and more exact approach. Characterization of this response using Planck's equation and an 8 to 14 μm response is shown in Figure 11.

4.2.2 Emissivity

Real objects are not perfect blackbodies. The energy emitted from an object's surface at any wavelength is a combination of self emission and reflection in a ratio determined by surface emissivity. An object whose surface has an emissivity of 0.8 emits energy composed of 80% self emission and 20% reflected background. A radiometric measurement would have an error equal to 20% of the difference between object and background radiances unless proper correction is made (with an estimated background level).

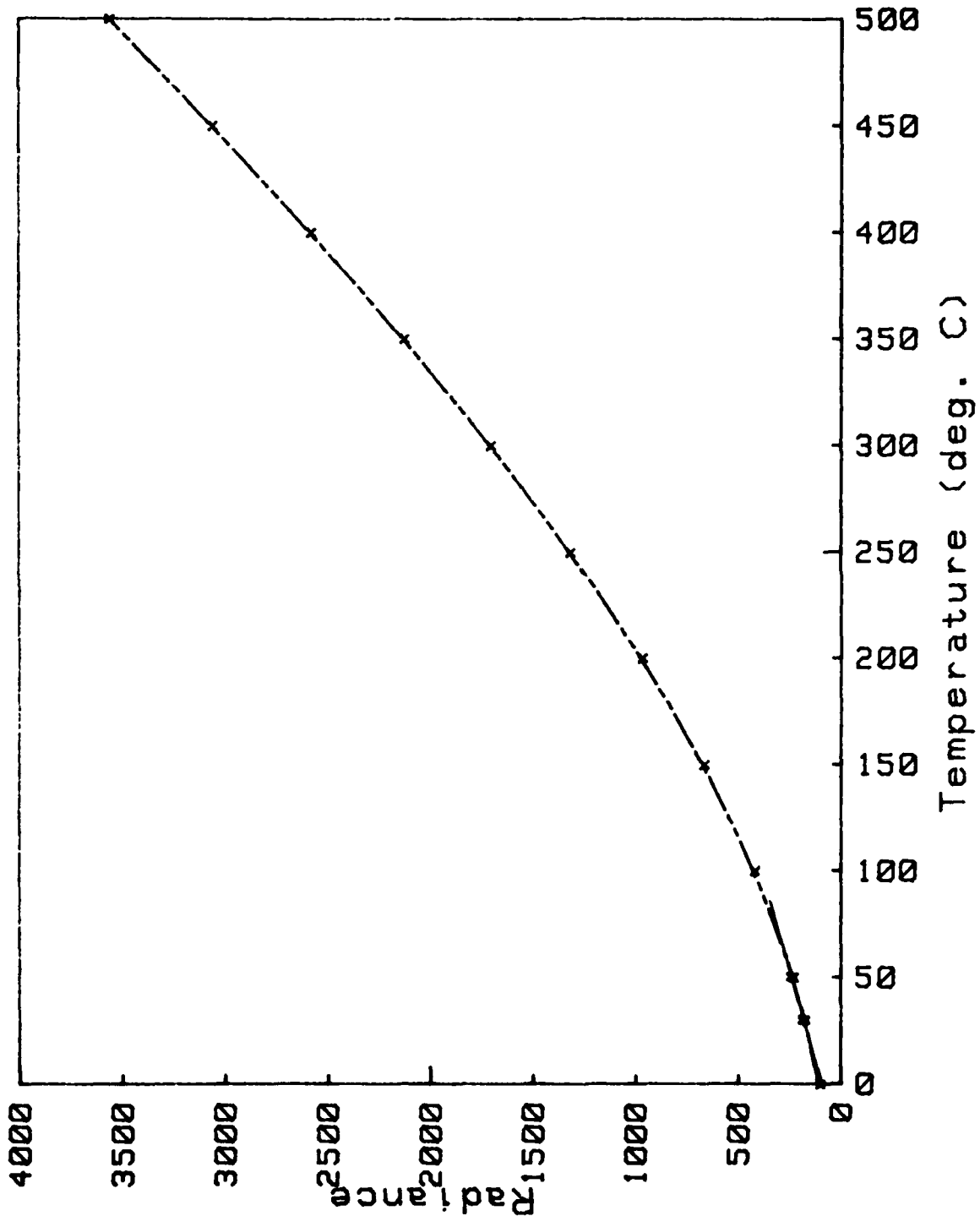

Figure 11. 8 to 14 μ m Detector Response

4.2.3 Objective Lens Losses

Radiometric measurements made with the WDRF are based on comparisons of internal (field stop) reference target radiation with radiation from objects in the field-of-view. Radiation from external objects passes through the objective lens set (telescope), while field stop radiation does not. Losses and self emission in the objective lenses contribute a small error that may be compensated for by monitoring the lens temperature (great accuracy is not necessary) and correcting readings as follows:

$$T_t = \frac{(T_m - T_o)}{\tau} + T_o$$

where

- T_t = true target temperature
- T_o = lens temperature
- T_m = measured apparent temperature
- τ = lens transmission (total) 0.98

Note that temperatures rather than radiances have been used for simplicity.

APPENDIX A
ACCEPTANCE TEST PROCEDURE
FOR
WIDE DYNAMIC RANGE FLIR

ACCEPTANCE TEST
PROCEDURE FOR
WIDE DYNAMIC RANGE FLIR

AUGUST, 1981

Arnold H. Bach

PREPARED BY

[Signature]

APPROVED BY

APPROVED BY

PREPARED FOR:

DEPARTMENT OF THE AIR FORCE
AIR FORCE SYSTEMS COMMAND
AERONAUTICAL SYSTEMS DIV/PMREA
WRIGHT-PATTERSON AFB, OH 45433
CONTRACT NO. F33615-81-C-1493

By:

HONEYWELL ELECTRO-OPTICS OPERATIONS
2 FORBES RD.
LEXINGTON, MASS. 02173

1.0 SCOPE

This document presents the procedures by which the Honeywell Electro-Optics Operation will evaluate quantitatively the system parameters of the Wide Dynamic Range FLIR.

2.0 REFERENCE DOCUMENTATION

Purchase Request/Project No. FY1175-81-00717 Section C.

3.0 ACCEPTANCE TEST PROCEDURE

3.1 Environmental Conditions

Testing will be conducted at standard laboratory conditions of $+23^{\circ}\text{C} \pm 10^{\circ}\text{C}$, less than 90% relative humidity, atmospheric pressure between 28 and 32 inches of mercury.

3.2 Test Set-Up

All tests will be conducted with the system mounted on a I.R. Collimator test bench. Infrared test patterns will be mounted at the focal point of the collimator to simulate targets at infinity. Calibrated IR attenuators will be used in conjunction with the target to simulate various temperature differentials between target and background. A standard lab TV monitor will be used for MRT tests, a 100MHz oscilloscope and true RMS voltmeter will be used for the MTF, NET, and dynamic range tests, and a standard lab DVM will be used to monitor temperature of the radiometric references on the field stop.

3.3 Performance Tests

Performance tests for the WDRF are:

- A. Dewar Hold Time
- B. Radiometric References
- C. FLIR Analog Processor
 - 1. Narrow Range Output
 - 2. Wide Range Output
- D. External Clock Input
- E. Optical System
 - 1. MTF
 - 2. MRT
- F. Detector
- G. Frame Interlace

3.4 Procedure

3.4.1 Dewar LN₂ Hold Time

The dewar will be filled with liquid nitrogen and covered. Cooldown time (as indicated by an active video signal) will be measured.

3.4.2 Radiometric References

The temperature of each radiometric reference will be monitored through its respective thermistor output. One source will be approximately at ambient temperature (a slight temperature rise is caused by the scanner) while the other source will be electronically maintained to $20^{\circ}\text{C} \pm 5\%$ above the ambient source once the system has stabilized. Manufacturers data sheets showing tolerance of the thermistors used will be supplied to demonstrate measurement accuracy. The wide range outputs will be displayed on an oscilloscope to verify the presence of the radiometric references in the video waveform.

3.4.3 FLIR Analog Processor

3.4.3.1 Wide Range Output

The wide range outputs will demonstrate an unsaturated excursion through a minimum dynamic range of 65dB. The dynamic range will be referenced to NE Δ N (NE Δ N is the noise equivalent radiant emittance difference, in band, around ambient temperature). The NE Δ N will be measured by disabling both vertical and horizontal mirrors and measuring the RMS noise at both preamp outputs (it is not possible to measure the RMS noise voltage at the wide range output due to the clamp and AGC circuits). After enabling the system scanning mechanisms, a signal voltage will be measured using an extended area black body source against an ambient (300°K) background. The black body will be set at a series of five temperatures with corresponding radiant contrast levels at equally speed intervals to show a linear output with radiance to 65dB above the measured NE Δ N. The output levels will be within ± 2 volts and remain unsaturated through the dynamic range specified for the system. A curve showing temperature to radiance conversion will be computed in advance, using estimated spectral band pass parameters.

3.4.3.2 Video Monitor Output

The output will be displayed on an oscilloscope to demonstrate EIA RS170 compatibility. Ability to vary the thermal offset level from approximately 50°C below ambient to 250°C above ambient will be shown. Positive offset will be tested by using the level adjust control to view the black body source used in Section 3.4.3.1 while at the maximum (+65dB) temperature. An ice bath will be used to test negative offset of 25°C below ambient, and further negative offset must be estimated.

3.4.3.2 (Cont.)

The gain control will be shown to vary the output range from a 10°C display range to 100°C display range. This test will be run concurrently with the wide range output test.

3.4.3.3 External Clock Input

Demonstration of the compatibility of the system with an external clock will be made. The external clock shall be a square wave with a frequency of 2.04545 MHz \pm 10 Hz. The Voltage swing of the clock will be \pm 5 volts. The narrow range output will be shown to be RS-170 compatible with an external clock. The external clock frequency will be varied, and video sync will be shown to vary with clock frequency using a dual trace oscilloscope.

3.4.3.4 Optical System

MTF and MRT measurements will be made to qualify system performance. The MTF measurement demonstrates the system's spatial frequency response. The vertical mirror will be disabled, and a 3"x3" black body source will be set to a 10°C or greater Δ T so that a low spatial frequency target produces a clean square wave signal at the preamplifier or wide dynamic range outputs.

Bar targets of 0.5, 1.0, 2.0, 3.0, 4.0 and 5.0 cycles/milliradian will be inserted and peak-to-peak modulation produced, referenced to a large (D.C.) target, will be measured and converted to percent MTF.

The MRT measurement defines the overall performance of the system by taking into account thermal sensitivity, optical resolution, electronic processing, display quality, and the capabilities of the human eye. The test determines the dimmest temperature contrasts which will allow an observer to resolve the four bars of test patterns of varying size on the monitor (i.e., of varying spatial frequency).

Set the temperature controller to maintain a moderate differential between bar targets and background (typically 20°C). Dim room lighting so that the observers at the monitor see no glare.

The observers should adjust monitor controls and system controls to optimize their ability to detect and resolve the targets during the test.

Install a target into the temperature controller at the collimator's focal plane. Allow two or three minutes to make sure that the entire target comes into thermal equilibrium with the controlled blackbody.

3.4.3.4 (Cont.)

A set of calibrated attenuators shall be placed in front of the bar target. Attenuators will be removed individually until observers are able to identify all four bars of the target. Calibration of the attenuators and the collimator correction factor shall be substantiated by previously measured data.

For each target enter in paragraph 5.3 the target spatial frequency, the blackbody temperature difference, and the values of the attenuators being used at the point of threshold decision by the observers.

The MRT is then calculated by multiplying the target temperature difference by the values of the attenuators. The attenuators have been calibrated and are marked in percent transmission. In addition each calculation should include multiplication by one more factor, the collimator correction factor, which is 80%. This is part of the calibration of the test set up and takes into account the OTF of the collimating optics and the reflectivities of the optical surfaces.

3.4.3.5 Detector

Proof of compliance of the detector to the specification will be shown utilizing Honeywell documentation of final test measurements made prior to system integration.

3.4.3.6 Frame Interlace

It shall be demonstrated that a single detector channel (9 elements) is sufficient to scan all points in the field of view. A small (one TV Line) target on a vernier mount will be raised slowly through a several TV line vertical displacement, while the resultant video signal is displayed on an oscilloscope.

FILMED

05-8