

AD-A113 736

SIPPICAN OCEAN SYSTEMS INC MARION MA
THE DEVELOPMENT OF AN AIR-LAUNCHED EXPENDABLE SOUND VELOCIMETER--ETC(U)
FEB 82
R-1127

F/G 14/2

N00014-79-C-0373

NL

UNCLASSIFIED

1 of 1
AD-A
113736



END
SERIALIZED
05-82
DTIC

R-1127
AIR-LAUNCHED EXPENDABLE SOUND
VELOCIMETER (AXSV)
FINAL REPORT

AD A113736

Meeting Operational Requirements

Sippican's demonstrated capability in the design and manufacture of expendable oceanographic instruments and communication systems supports the environmental prediction and tactical requirements of The Fleet.

The expendable bathythermograph (XBT) is a self-contained thermal profiler of the world. It provides accurate, direct measurements of temperature and velocity profiles. The SSXBT adds an expendable current profiler to the tools available to the oceanographer.

The SSXBT and SSXSV allow the submarine to obtain temperature and sound velocity profiles with the same ease and accuracy as surface ships.

SLOT, a submarine launched VHF communications buoy insures the reliable transmission of a pre-recorded voice or CW message from the submarine to surface ships or aircraft.

SLATE, another VHF communications buoy provides a two way tactical voice capability.

The AXBT bathythermograph and the AXSV extend Sippican's environmental profiling capability to aircraft.

The SUS activates on impact with the water and transmits a coded acoustic signal for aircraft to submarine communications.



AN/SSQ-36 • AXSV • SUS/MK-84

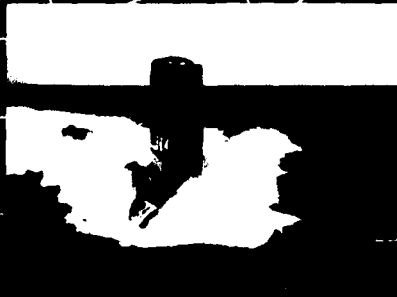

BQH-7 • AN/BRT-1 • AN/BRC-6

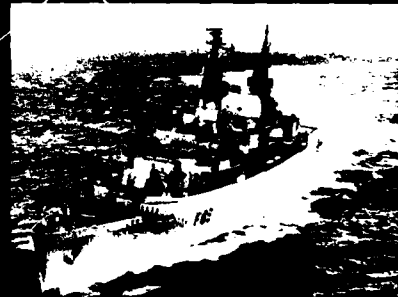

XBT • XSV • XCP

Distributed by

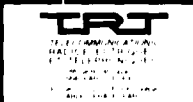

DTIC FILE COPY

Marion, Massachusetts 02738 USA
(617) 748-1160 Telex 929437

SIPPICAN MEETS OPERATIONAL REQUIREMENTS

Until the early 1960's, acoustic prediction systems relied on temperature profiles taken with winch lowered bathythermographs. This cumbersome, time consuming method limited speed and maneuverability and exposed personnel to a significant hazard in heavy seas.

In 1963 Sippican, recognizing the operational requirement for a thermal profiler that could be deployed without speed or maneuvering restrictions, developed the Expendable Bathythermograph (XBT). The XBT, which revolutionized the art of ocean temperature measurement, met the operational requirements of the Navies of the world and helped bring the use of propagation loss profiles, range prediction and acoustic-ray path theory from the laboratory to the fleet.

Large numbers of Expendable Probes (XBT, XSV and XCP) are deployed daily from surface ships, submarines and aircraft in the study of ocean structure as it relates to seasonal and geographical distribution of salinity and density and their effect on sound propagation, general circulation, heat budget, currents, upwelling, and phenomena such as internal waves, ocean fronts and eddies.

Rapid, Creative Response

Sippican's long history of involvement in the design and manufacture of expendable devices for use in the ocean environment has repeatedly demonstrated the capability to respond rapidly and creatively to the changing needs of military, scientific, and commercial customers.

Working closely with various Naval Systems Commands, Sippican has developed new and improved oceanographic instruments, submarine communications devices and associated data processing systems to meet a wide variety of operational requirements.

Sippican's Marion facility employs over 300 professional, technical, and manufacturing personnel. Their extensive backgrounds in ASW, Acoustics, Ship Operations, Oceanography, and Marine Biology, as well as the related engineering, manufacturing, and data management skills, insure responsiveness to customer's needs. Sippican's size facilitates the integration of engineering design, manufacturing and quality control from conception to product delivery so that response is innovative and timely. At all stages of product development Sippican has demonstrated its ability to work as a team with Naval Systems Commands, military users, scientific personnel and research labs of the world.

DOD Requirements Met

As a prime contractor to the U.S. Navy, Sippican's testing and quality procedures meet the stringent requirements of the U.S. Department of Defense.

Sippican's people and facilities are fully equipped to meet the challenges presented by customers' special needs, and the engineering demands imposed by the constant growth of oceanographic requirements. Their real field experience in these technical and professional areas makes Sippican an acknowledged world leader in oceanographic instrumentation.

Innovation has been the key word in Sippican's history. The innovative design, manufacturing and quality assurance techniques which were responsible for the success of the XBT, were employed in projects during the 1970's to broaden the company's contribution to oceanographic measurement. These same skills will anticipate and meet the needs of the 80's.

Sippican
Ocean Systems

Barnabas Road, Marion, MA 02738
(617) 748-1160 Telex: 929437

②

SIPPICAN REPORT R-1127
PREPARED UNDER CONTRACT N00014-79-C-0373

THE DEVELOPMENT OF AN
AIR-LAUNCHED EXPENDABLE SOUND VELOCIMETER
(ASXV)

Sippican Ocean Systems, Inc
Marion, MA 02738

20 February 1982

FINAL REPORT

Prepared For
Naval Ocean Research and Development Activity
NSLT Station, MS 39529

DTIC
SELECTED
APR 22 1982
S H
[Signature]

DISTRIBUTION STATEMENT A

Approved for public release;
Distribution Unlimited

*Original contains color
plates. All DTIC reproductions
will be in black and
white.

82 01 00 067

PREFACE

This report is a summary of the work accomplished under contract N00014-79-C-0373 to develop an Air Launched Expendable Sound Velocimeter (AXSV). The intent of this program was to utilize standard hardware from Sippican's Air Expendable Bathythermograph (AXB T) and surface ship launched Expendable Sound Velocimeter (XSV) whenever possible. Several tests were conducted during the design development phase of this program to demonstrate design feasibility. Although these tests showed the feasibility of the AXSV design, additional testing will be required to improve system reliability prior to producing these units in large quantities. Sippican is now preparing to do this in an internally funded test program.

Accession For	
NTIS GRA&I	<input checked="" type="checkbox"/>
DTIC TAB	<input type="checkbox"/>
Unannounced	<input type="checkbox"/>
Justification	
By <i>Per H. on file</i>	
Distribution/	
Availability Codes	
Dist	Avail and/or Special
<i>A</i>	



TABLE OF CONTENTS

<u>SECTION</u>		<u>PAGES</u>
1.0	Introduction	1-2
2.0	Design	3-4
3.0	Operation	5-6
4.0	Test Program	7-8
5.0	Conclusions & Recommendations	9
Appendix A	XSV Data Sheet	
Appendix B	AXSV Probe Drop Rate Calculation (Preliminary)	
Appendix C	AXSV Probe Drop Rate Calculation (Final Design)	

SECTION 1

INTRODUCTION

Sippican Ocean Systems, Inc. of Marion, MA is submitting this Final Report for the "Development of an Air-Launched Expendable Sound Velocimeter" to summarize the work accomplished under contract N00014-79-C-0373. During the past year Sippican has generated and tested a design for an Air Launched Expendable Sound Velocimeter (AXSV) which utilizes the hardware from both the Air Launch Expendable Bathythermograph (AXBT) and the surface ship launched Expendable Sound Velocimeter (XSV). The intent of this program was to use standard production hardware where possible to reduce development time and cost. In addition, if the high volume production hardware such as the AXBT were available when the AXSV went into production the cost of the AXSV could be reduced significantly.

Figure 1-1 shows the AXSV as it was configured in the original proposal. This design was based on the standard ship launched XSV being inserted into the AXBT which was being manufactured for the Navy in our Set Aside contract of 2000 buoys. Since that time, Sippican has been awarded a contract to manufacture approximately 42,000 AXBT's for the Navy. This was a competitive bid with two other manufacturers with lowest price being the only criteria for the contract award. To win this award Sippican had to redesign the mechanical system of the AXBT (electrically and performance-wise it was the same) to reduce material cost and assembly time while increasing the overall performance reliability. This redesign was being undertaken at the same time as the AXSV was being developed. It would have been unfair to develop the AXSV based on hardware which was not going into production, thus Sippican based the AXSV design on the system which was under development. Because of this, the original time goals for this program were not met. In addition, the amount of development required was greater since the standard ship launched XSV did not interface with the new AXBT. However, the design which did evolve from the program is far more affordable than if the original concept had been pursued. Figure 1-2 shows the AXSV design which was developed during this program.

Four major tests were conducted during this program to develop the AXSV hardware and to demonstrate system feasibility. They were a probe drop rate test at the Underwater Weapons tank at NSWC, an over-the-side deployment test in local waters to check the probe and surface electronics system performance, and two air launch tests at the Sonobuoy Quality Assurance Facility in St. Croix to check the complete buoy performance.

This report will review the background of the XSV, the design of the AXSV and the development testing during this program.

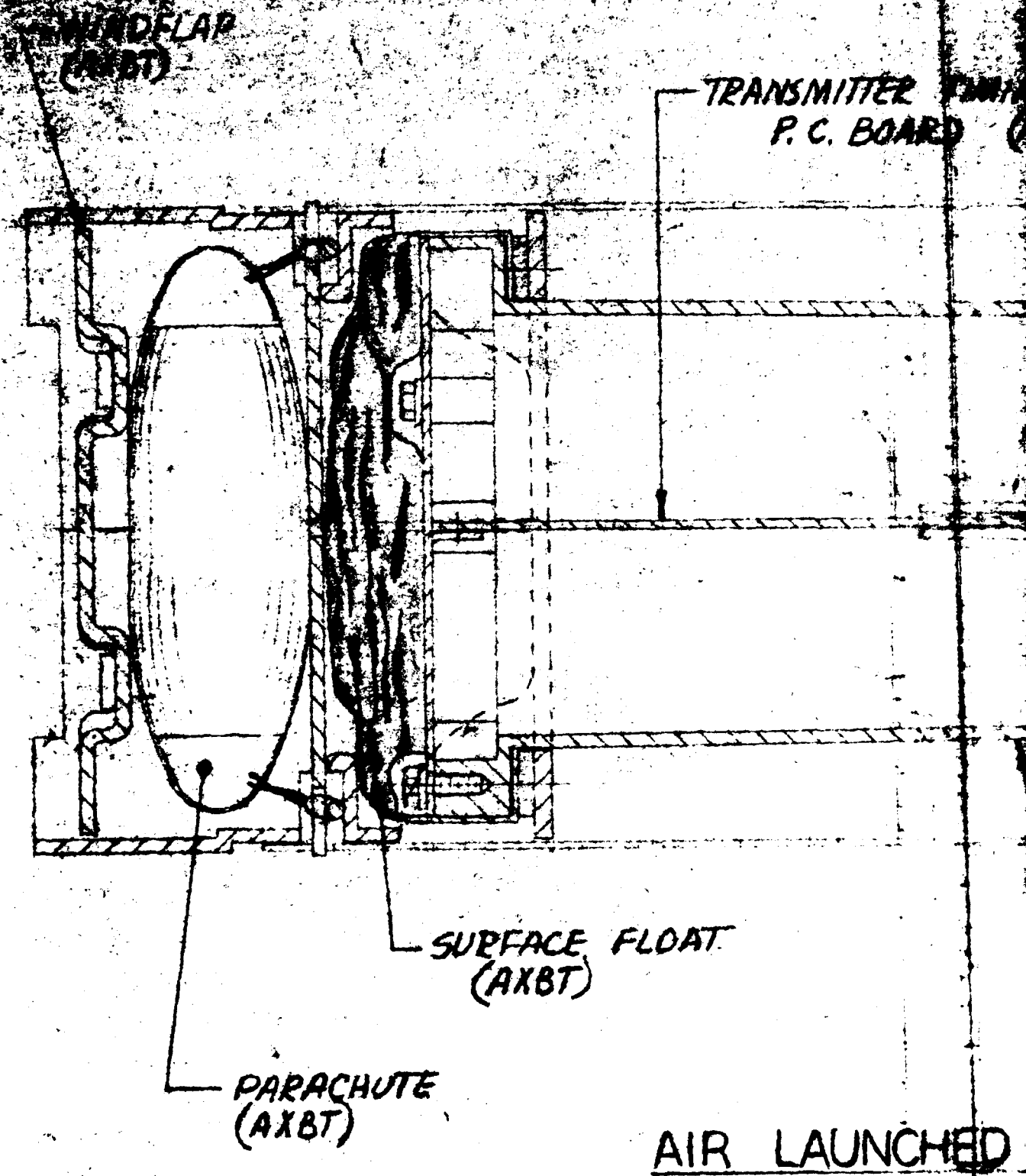

THIS PAGE IS BEST QUALITY PRACTICABLE
FROM COPY FURNISHED TO DDC

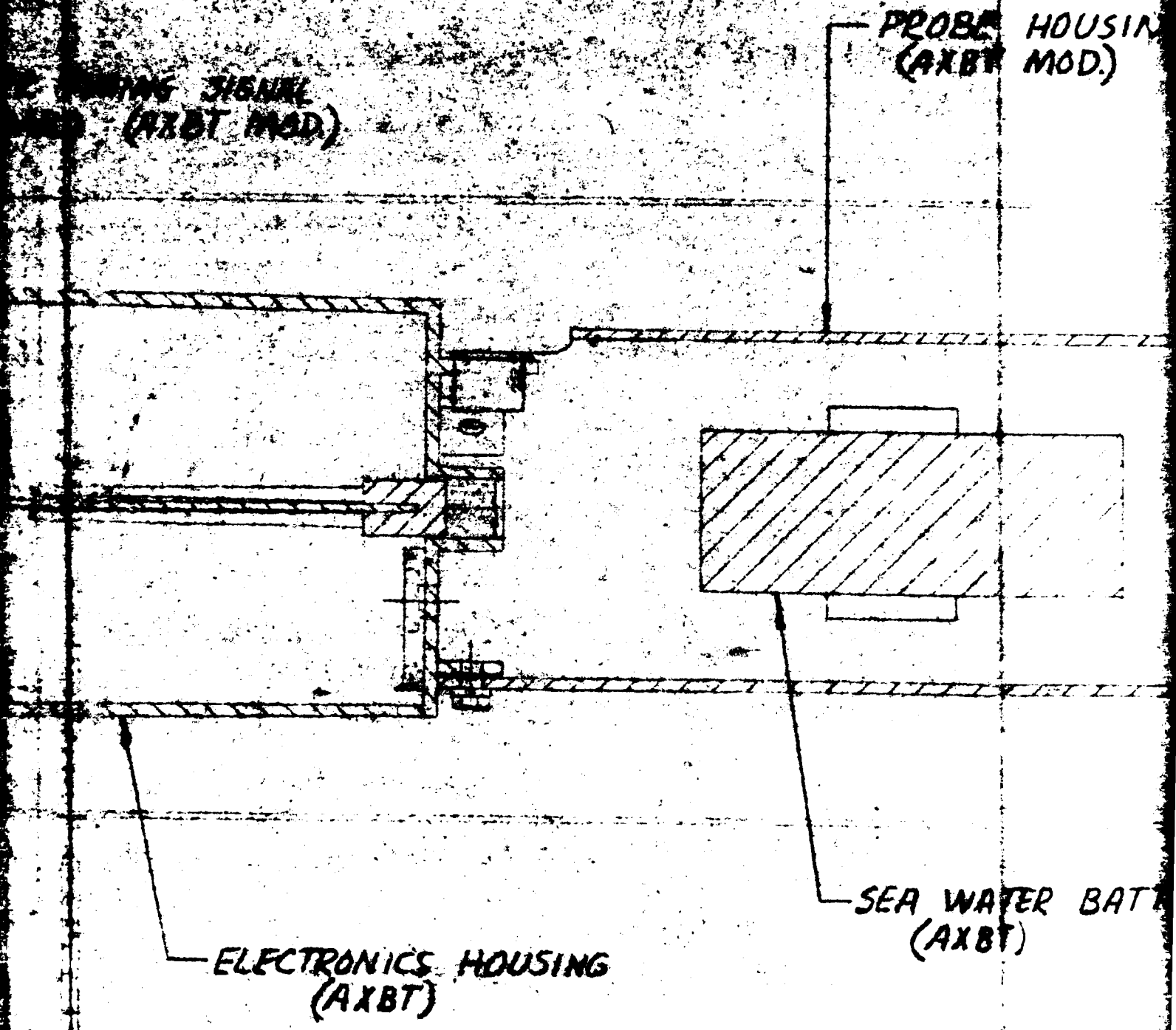

MOD EXPENDABLE SOUND VELOCIMETER

AXBT

HOUSING
(MOD.)

SEAKEEPING SPOOL

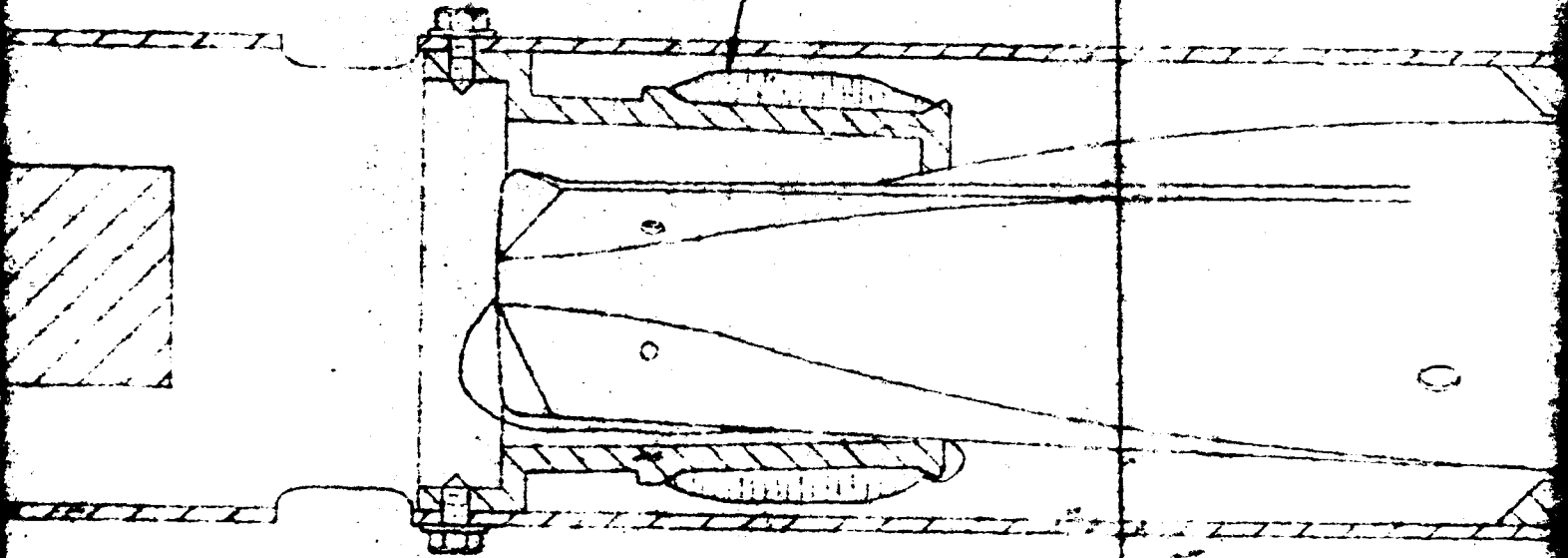

WATER BATTERY

PROBE RELEASE MECH

AXSV

FIGURE I-1

13

SPOOL

BUOY HOUSING

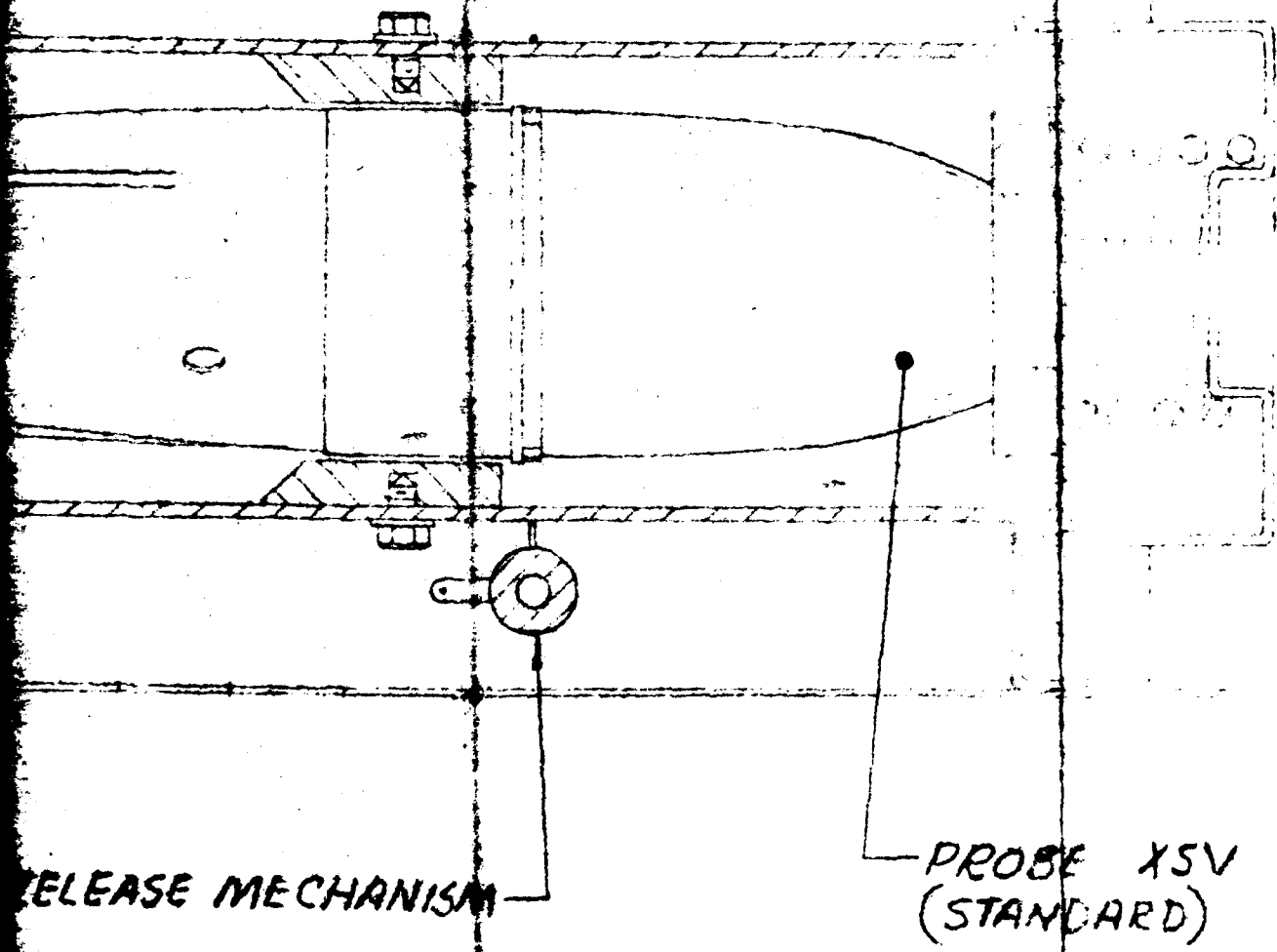

RELEASE MECHANISM

PROBE XSV
(STANDARD)

THIS PAGE IS BEST QUALITY PRACTICABLE
FROM COPY FURNISHED TO DDC

15

AXSV

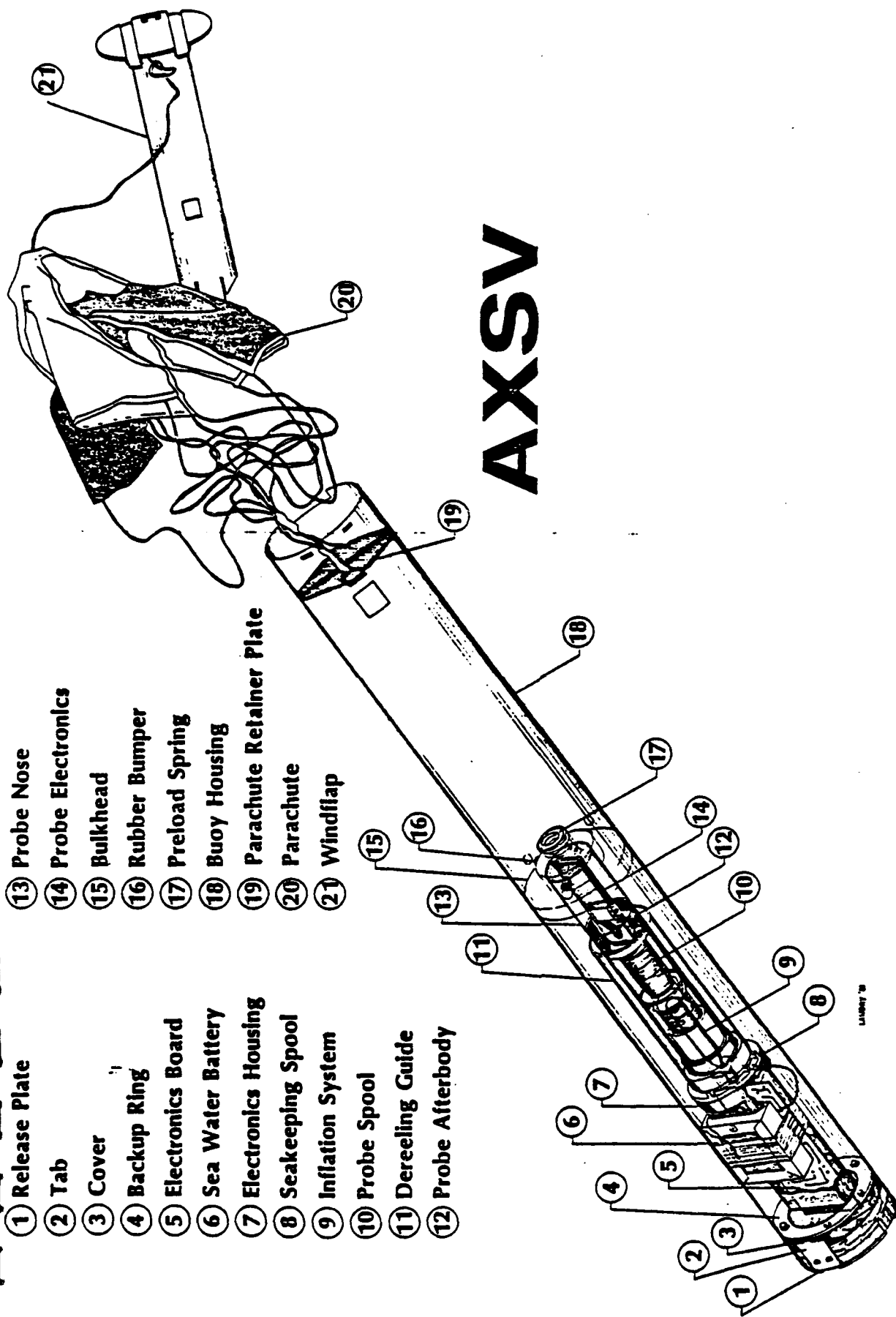

- ① Release Plate
- ② Tab
- ③ Cover
- ④ Backup Ring
- ⑤ Electronics Board
- ⑥ Sea Water Battery
- ⑦ Electronics Housing
- ⑧ Seakeeping Spool
- ⑨ Inflation System
- ⑩ Probe Spool
- ⑪ Dereeling Guide
- ⑫ Probe Afterbody
- ⑬ Probe Nose
- ⑭ Probe Electronics
- ⑮ Bulkhead
- ⑯ Rubber Bumper
- ⑰ Preload Spring
- ⑱ Buoy Housing
- ⑲ Parachute Retainer Plate
- ⑳ Parachute
- ㉑ Windflap

FIGURE 1-2

BACKGROUND

Some of the earliest recorded measurements of the speed of sound in water were made on Lake Geneva in 1826 by the young investigators Daniel Colladon and Charles Sturm. Their measurements were made using two specially-equipped small boats. The "source" boat was equipped with an underwater bell which could be rung by an external clanger remotely operated from the boat. At the same time as the bell was rung, a flash of light was generated onboard which could be seen as much as ten miles away. The "receiver" boat used an underwater trumpet and stopwatch, timing the interval between the flash of light and receipt of the acoustic signal. Colladon and Sturm's measurements in the 8°C Lake Geneva water agreed to within 3 meter/sec with the value accepted today.

Since 1826, the field of underwater acoustics and the need for rapid, accurate measurements of underwater sound velocity have greatly expanded. This expansion was initially in response to the need for accurate echo soundings in bathymetry work (navigational safety). However, the real fuel for this expansion has been the need for equipment and techniques capable of countering the wartime threat posed to shipping by hostile submarines.

With the advent of reliable echo-ranging sonar, vagaries in the performance of the sonar which could only be attributed to changes in the sound transmission characteristics of the seawater itself, became evident. It is now known that large temporal and spatial variabilities exist in ocean sound speed profiles which greatly influence the effectiveness of short-and long-range sound propagation.

Most recent sound velocity measurements are made using sound velocity and pressure (depth) transducers attached to a cage which is lowered over the side of a stationary vessel by means of an electro-mechanical cable. Such measurements are both costly in terms of ship and personnel time and restrictive in terms of vessel movements.

In order to reduce the difficulties associated with at-sea collection of sound speed data, Sippican, in conjunction with Van der Heem Electronics of the Netherlands, undertook a development program to design and produce an Expendable Sound Velocimeter (XSV). This program resulted in a probe capable of sound speed measurements to an accuracy of ± 0.25 meters/sec with the same ease in data taking provided by the Expendable Bathythermograph (XBT). Figure 1-3 shows the XSV. Appendix A includes a data sheet for the product.

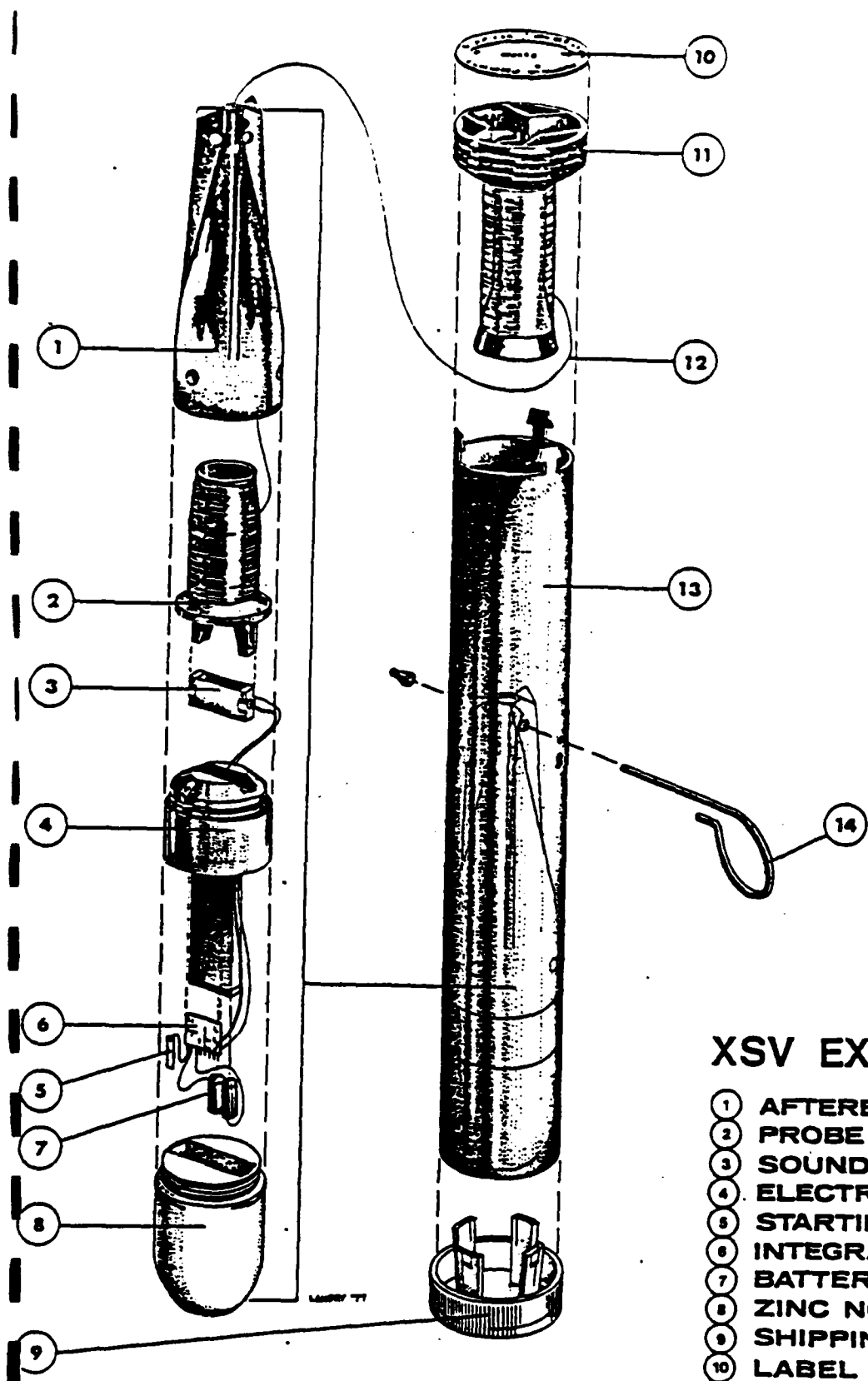

XSV EXPLODED VIEW

- ① AFTERBODY
- ② PROBE SPOOL
- ③ SOUND VELOCITY SENSOR
- ④ ELECTRONICS HOUSING
- ⑤ STARTING CONTACT
- ⑥ INTEGRATED CIRCUIT
- ⑦ BATTERIES
- ⑧ ZINC NOSE
- ⑨ SHIPPING CAP
- ⑩ LABEL
- ⑪ SHIPBOARD SPOOL
- ⑫ SIGNAL WIRE
- ⑬ CANISTER
- ⑭ RETAINING PIN .

Figure 1-3

SECTION 2

AXSV DESIGN

The AXSV baseline design is shown in Figure 1-1. As designed it is an "A" size buoy (36 inches long by 4.75 inches in diameter) and weighs 13 pounds prior to air launch. Figure 2-1 shows an exploded view of this unit. Located at the bottom end of the buoy is the release plate. This plate serves the dual function as the buoy water impact plate and after water impact it releases the internal components from the buoy housing. Behind this plate is the flotation bag. This bag is attached to the top of the surface electronics housing and is used to both provide buoyancy to the surface unit and to support the RF antenna.

Located within the die cast zinc electronics housing is a single electronics board which contains the $\frac{1}{2}$ watt RF transmitter, timing circuits and probe signal conditioner. A 12 volt seawater battery is taped to the outside of the electronics housing. This battery is grounded to the electronics housing with one lead while the positive lead feeds through a potted cavity to the electronics board. Activation of the battery occurs as soon as it is submerged in sea water. This battery is used to power the surface electronics housing only. The seakeeping spool forms the lower bulkhead of the surface electronics housing. Located within this spool is the CO₂ float inflation system. This system consists of a squib, piercer, housing, and a sealed bottle containing 8 grams of CO₂. Single conductor BT wire is wound on the outside of this spool as part of the dual spool dereeling system.

Interlocking with the seakeeping spool is the XSV probe designed for this program. It is a hybrid of the AXBT probe and the surface ship XSV probe. The probe consists of the AXBT afterbody with a modified XSV probe spool, wire and electronics, and a modified AXBT probe nose (die cast zinc). A wire dereeling guide, which is attached to the seakeeping spool at one end, forms the outer wall of this assembly before the probe release. A preload spring between the buoy housing bulkhead and the probe nose keeps the internal components of the AXSV assembly in compression prior to water impact and separation.

At the top end of the buoy is the windflap which serves the dual function of enclosing that end of the buoy housing and at launch extracts the parachute from the cavity below. The parachute is a rectangle chute and has been designed to meet all the new Navy requirements for launch from ASW aircraft. Enclosing the entire AXSV is a galvanized steel outer housing. This housing provides protection to the internal components before and during launch but is discarded after water impact.

AXSV
 air launched
 expendable
 sound velocimeter

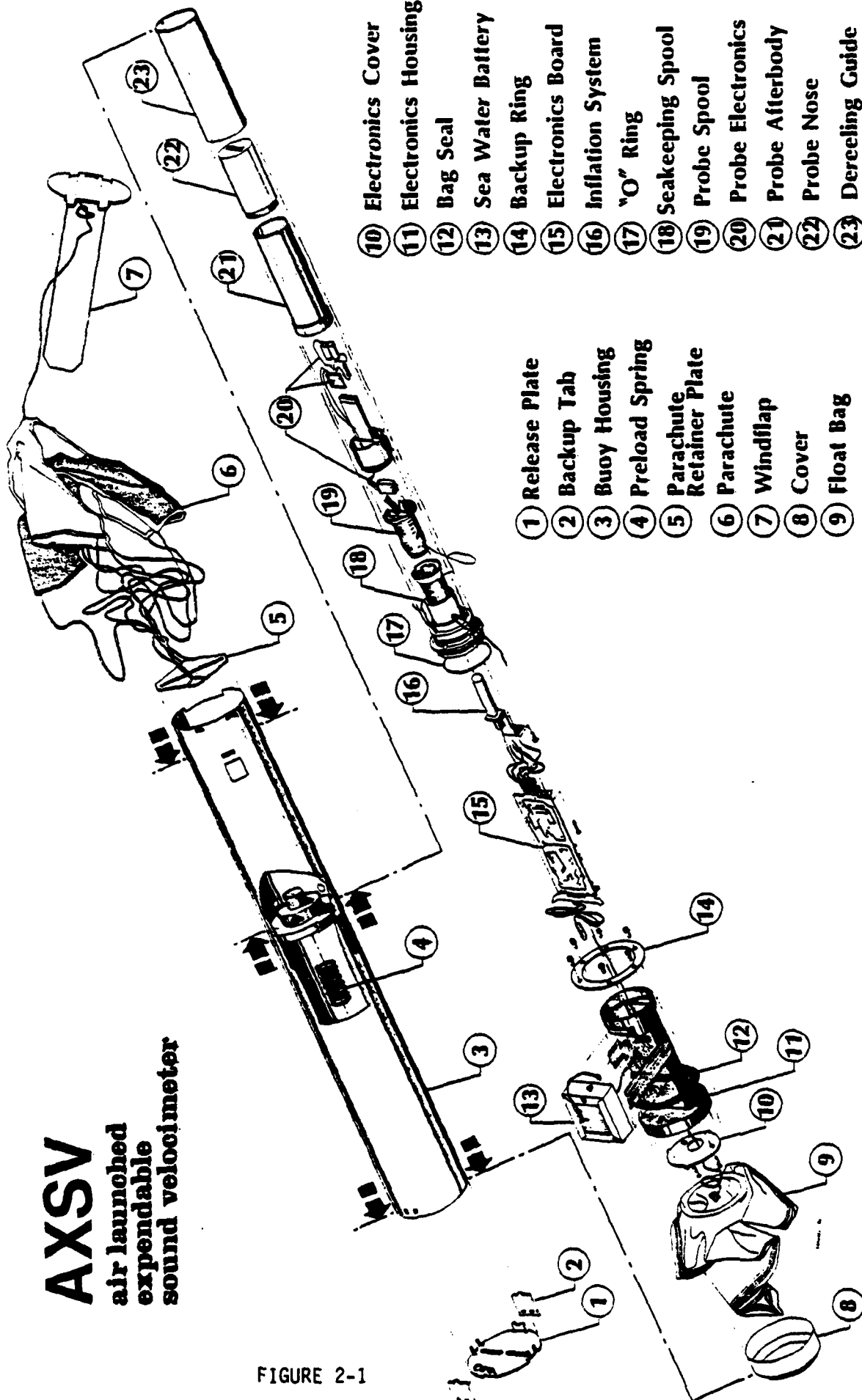

- ① Release Plate
- ② Backup Tab
- ③ Buoy Housing
- ④ Preload Spring
- ⑤ Parachute Retainer Plate
- ⑥ Parachute
- ⑦ Windflap
- ⑧ Cover
- ⑨ Float Bag

- ⑩ Electronics Cover
- ⑪ Electronics Housing
- ⑫ Bag Seal
- ⑬ Sea Water Battery
- ⑭ Backup Ring
- ⑮ Electronics Board
- ⑯ Inflation System
- ⑰ "O" Ring
- ⑱ Seakeeping Spool
- ⑲ Probe Spool
- ⑳ Probe Electronics
- ㉑ Probe Afterbody
- ㉒ Probe Nose
- ㉓ Dereeling Guide

FIGURE 2-1

As noted earlier, the AXBT was the basis for this design. Figure 2-2 is an exploded view of the AXBT. Comparing the two designs, the differences are as follows.

1. Electronics board (item 15) - The value of six components changed; all other circuits identical.
2. Buoy Housing (item 3) - The location of the bulkhead changed to account for longer probe nose.
3. Probe Spool (item 19) - Modified XSV probe spool replaced AXBT probe spool. Two-conductor BT wire replaced with single-conductor BT wire (standard on XSV).
4. Probe Electronics (item 20) - XSV electronics in modified housing replaces the AXBT electronics.
5. Probe Nose (item 22) - Combination of the XSV and AXBT probe nose designs forms a new hybrid nose.

All other hardware is common between the AXSV and AXBT.

AXBT
 air launched
 expendable
 bathythermograph

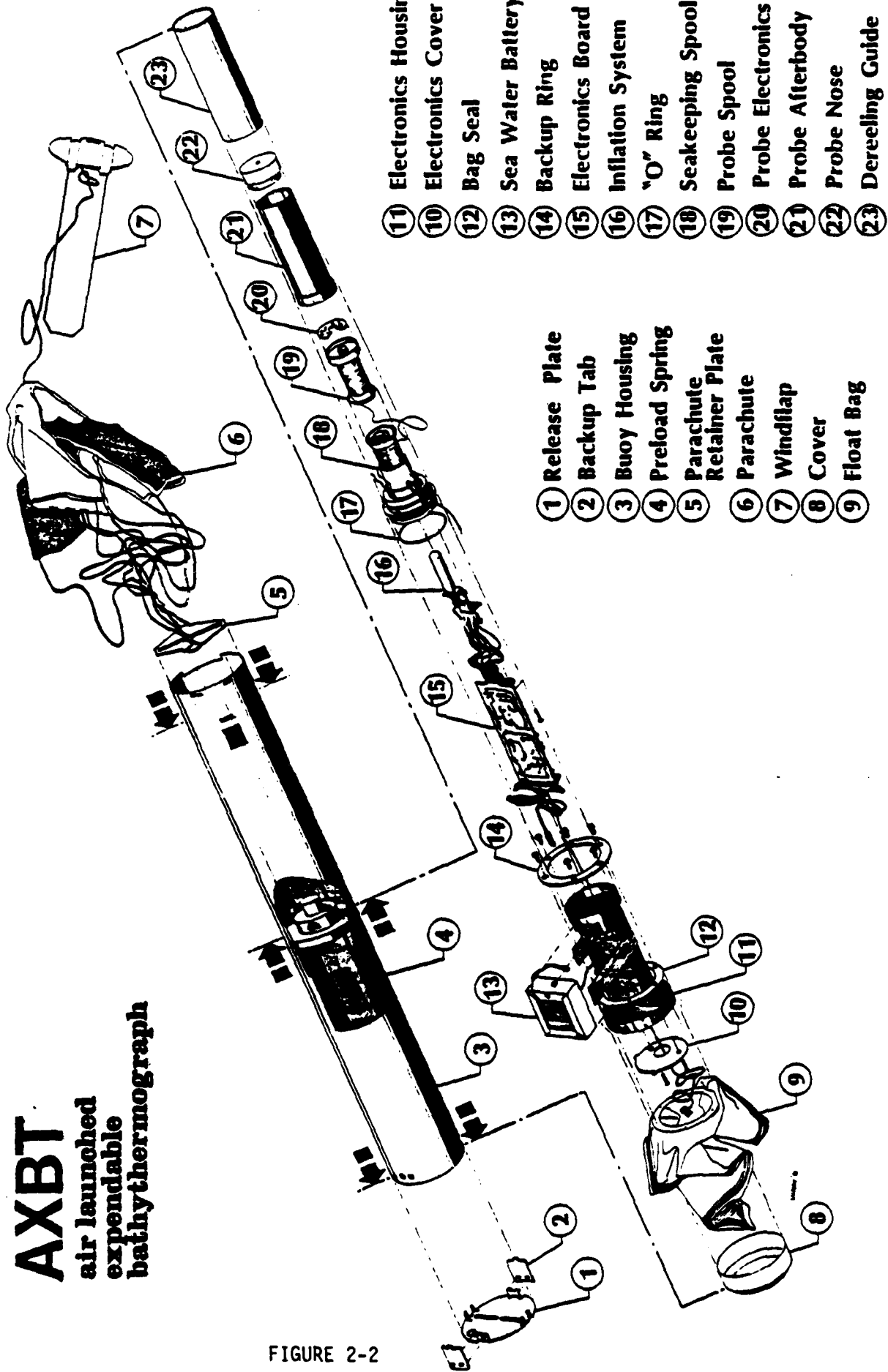

- ① Release Plate
- ② Backup Tab
- ③ Buoy Housing
- ④ Preload Spring
- ⑤ Parachute Retainer Plate
- ⑥ Parachute
- ⑦ Windflap
- ⑧ Cover
- ⑨ Float Bag

- ⑩ Electronics Housing
- ⑪ Electronics Cover
- ⑫ Bag Seal
- ⑬ Sea Water Battery
- ⑭ Backup Ring
- ⑮ Electronics Board
- ⑯ Inflation System
- ⑰ "O" Ring
- ⑱ Seakeeping Spool
- ⑲ Probe Spool
- ⑳ Probe Electronics
- ㉑ Probe Afterbody
- ㉒ Probe Nose
- ㉓ Dereeling Guide

FIGURE 2-2

SECTION 3

BUOY OPERATION

AXSV's can be launched from a number of Navy ASW aircraft over a wide range of launch altitudes and launch speeds. The most predominate of these are the S-3 and P-3 aircraft. Standard sonobuoy receivers such as the AN/ARR-52 and -72 are used to receive and demodulate the AXSV RF signal. The output frequency can then be displayed on an AQA-7 processor or into a MK-9 Digital XBT/XSV system. Figure 3-1 shows the data sheet for the MK-9 system.

Operation of the AXSV begins when the buoy is launched from the aircraft. As the buoy separates from the launch aircraft, the windflap rotates into the wind stream and deploys the parachute aft of the buoy housing. This parachute stabilizes and controls the buoy's air descent to water impact (water impact speeds are approximately 100ft/sec).

After water impact, the buoy housing floods and the seawater battery is activated. An electrode located at the base of the surface housing is used to complete the firing circuit for the float bag inflation system. After this circuit is completed the seawater battery powers a small squib which propels a piercer into a CO2 bottle. This ruptures the bottle allowing the CO2 gas to escape and inflate the float bag. As the bag begins to inflate it bends the impact/release plate, extracting the retaining fingers from the buoy housing. When this happens, the expanding bag pushes the release plate and it separates from the buoy housing allowing the float bag to climb out. At this point, the buoy housing falls away with the parachute attached to it, leaving the surface float, electronics and probe system on the ocean surface. Buoyancy for this system is provided by the surface float bag which has been designed to erect the RF antenna located within.

After a fixed time delay of 33 seconds (after the activation of the sea water battery) power is sent to the probe release burn wire, causing it to rupture. This allows the probe to fall free from the surface assembly paying out wire (single lead 39 gauge) from both the seakeeping spool and probe as the probe descends. At this time, the audio output of the signal conditioner is switched to the transmitter and the depth vs sound velocity trace begins. The speed of sound in the water is proportional to the probe output frequency according to the following expression:

$$V_{m/sec} = \frac{(.052)(3.281)}{\frac{1}{128f} - 2.35 \times 10^{-7}}$$

where V is the speed of sound in meters/sec
f is the output frequency of the probe

MK-9 Digital XBT/XSV System

WORLDWIDE
TECHNICAL
SUPPORT
AVAILABLE

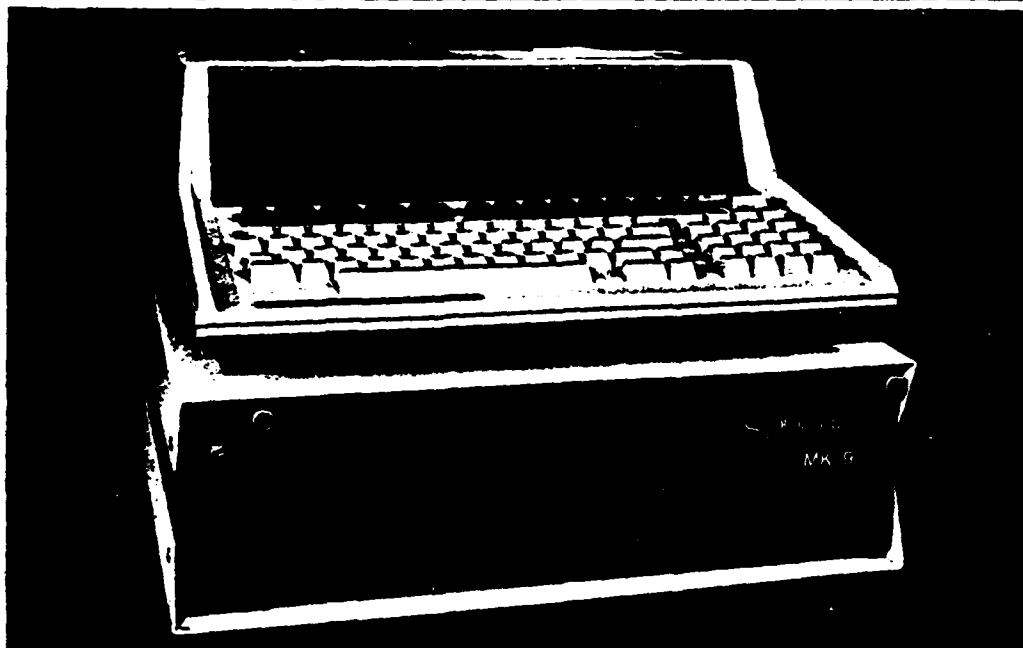

The MK-9 System has been developed by Sippican in response to the needs of scientific and commercial customers for a low-cost digital data system for XBT and XSV applications.

It may be used with any Sippican launcher, and its IEEE-488 interface is compatible with most computer systems, for plotting, recording and processing digital data.

MK-9 SPECIFICATIONS

Probe Type	Sampling Rate	Vertical Resolution	System Accuracy	Temp Resol.	Temp Range	Sound Velocity Resol.	Sound Velocity Range
XBT	10HZ	60CM (18CM for T-11 FSXBT)	±0.2°C	0.01°C	-2 to 35°C	—	
XSV	10HZ	60CM	0.25 M/sec.	—	—	0.04 M/sec.	1405-1550M/sec.
AXBT*	10HZ	15CM	±0.2°C	0.01°C	-2 to 35°C	—	

System Depth Accuracy: 4.6 Meters or 2% of depth (whichever is larger)

*External RF Demodulator required

- Bench top or 19" Relay Rack Mounted
- Output: IEEE-488 GPIB
- Software Documentation is now available for the HP-85 and HP-9845
- Power requirement: 115 VAC, 50 to 400Hz, 10 W

Call for more information

Sippican

Ocean Systems

Barnabas Road, Marion, MA 02738
(617) 748-1160 Telex 929437

The depth of the probe is determined by the time from release according to the following expression:

$$D = 1.500 + 6.10758t - .000260t^2$$

where D is the depth of the probe in feet and t is the time from release in sec.

At the end of the probe drop the transmitter shuts down and the surface unit scuttles.

SECTION 4

TEST PROGRAM

The baseline design shown in Figure 1-2 is the result of a design and development program which commenced in December 1980. Included in this development was an extensive test program of both the AXSV and AXBT hardware to refine the designs generated, collect performance data, and to develop confidence in the overall system's performance. Figure 4-1 shows the combined schedule of AXSV and AXBT testing. Most of this testing was for the AXBT program, however, as noted in section 2, most of the mechanical hardware for both the AXSV and AXBT is identical.

The first test in this sequence was the probe drop rate test conducted at the Underwater Weapons tank at Naval Surface Weapons Center in White Oak, Maryland. In this test both the new AXBT and AXSV probes were tested. Figure 4-2 shows the AXSV probe design used in that test.

In this design an attempt was made to maximize the probe drop rate while using the AXBT hardware and concept where possible. Although the AXBT probe was highly successful at this test, the AXSV probe with its low drag nose proved unstable. Attempts to add drag to the nose did improve stability. Additional testing at the Sippican 30 foot tank did produce a nose based on the AXBT high drag nose which was stable. Appendix B shows the analysis used to generate the initial drop equation used for this program. After the first air drop test this nose was modified again to reduce the nose weight. Appendix C shows the calculation for probe drop rate using that nose. Figure 4-2 shows the evolutionary process of the nose design.

During the next several months there were a series of air drop tests to develop the air launch/buoy separation system for both the AXBT and AXSV. Then in September three complete AXSV's were deployed over-the-side at Newport, RI (about 1200 feet of water depth). The purpose of that test was to verify the results of the electrical systems testing conducted in the Sippican engineering lab. This was a complete electrical systems test. All three systems worked without any problems.

A final air launch test was planned for early November 1981 at the Sonobuoy Quality Assurance Facility in St. Croix. Problems in the assembly of these units associated with the weight of the probe nose breaking the probe release wire reduced the number of units at this test to five. Five additional units were to be tested at a later date.

During the assembly of the AXSV several units had the probe release wire fail. This is not a repairable device thus these probes had to be scrapped.

AXBT/AXSV TEST SUMMARY

February 1981	Drop Rate Test-NWSC Underwater Weapons Tank	3 units
March-May 1981	Engineering Design Bridge Drops	30 buoys
30 June 1981	Dummy Air Drop-Buzzards Bay	4 buoys
8 July 1981	Dummy Air Drop-Buzzards Bay	6 buoys
5 August 1981	Vibration Test (AVCO)	1 buoy
21 August 1981	Full System Air Drop-Provincetown	6 buoys
28 August 1981	Full System Test-Newport Bridge	8 buoys
2 September 1981	Vibration Test (AVCO)	1 buoy
8 September 1981	Dummy Air Drop-Newport Bridge	5 buoys
18 September 1981	Vibration Test (AVCO)	1 buoy
25 September 1981	Full System Test-Newport Bridge	6 buoys
29 September 1981	Full System Test-Newport Bridge	8 buoys
21 October 1981	Full System Test-St. Croix	11 buoys
9 November 1981	Shock Test (AVCO)	3 buoys
1 December 1981	Shock Test (AVCO)	3 buoys
3 December 1981	Full System Air Drop-St. Croix	8 buoys
8 December 1981	Full Buoy Air Drop-Buzzards Bay	10 buoys
16 December 1981	Full Buoy Air Drop-Buzzards Bay	6 buoys
24 December 1981	Full Buoy Air Drop-Buzzards Bay	6 buoys
21 January 1982	Full Buoy Test-Key West	5 buoys
26 January 1982	Full Buoy Test-Newport Bridge	5 buoys
4 February 1982	Full Buoy Test-St. Croix	22 buoys
10 February 1982	High Altitude Full Buoy Test-St. Croix	5 buoys

Figure 4-1

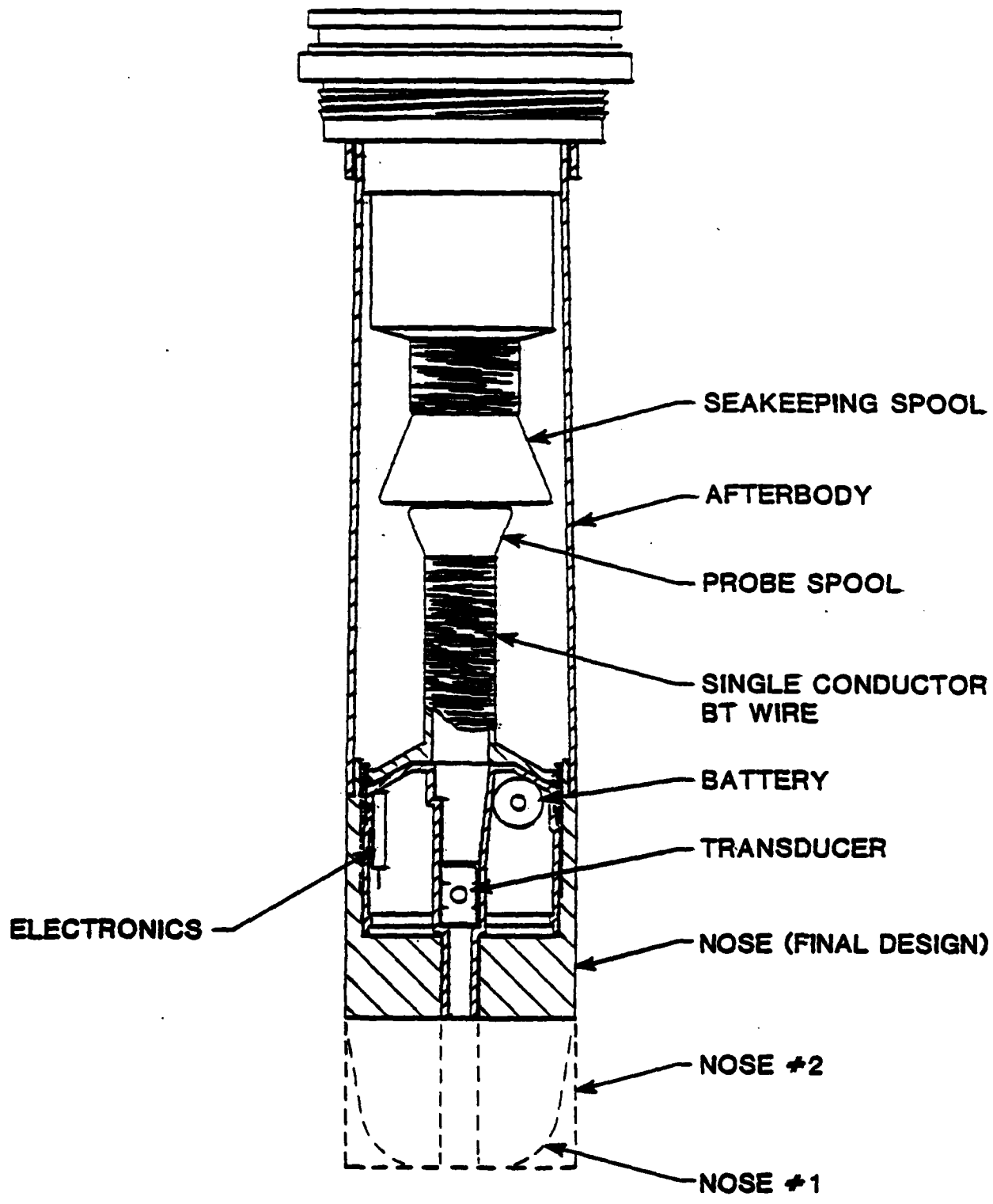

FIGURE 4-2

The release mechanism had been designed for the lighter weight AXBT nose. Because of the extra weight in the nose of the AXSV probe that system would tend to break the release wire if it were shocked during assembly. And since the AXBT production assembly tooling was not yet available this could happen at the final assembly. With the availability of the production tooling and a modification in the probe nose weight this problem was eliminated the next time buoys were fabricated.

The results of this air drop test is shown in Table I. Three of the five units produced good traces. Of the two that failed, one was a RF failure after 1 min 57 sec after splash down (serial number 029) and the second unit (serial number 024) had a free running transducer in the probe. An investigation into the RF failure showed that the output transistor had failed. This was a result of the warm test conditions and high battery voltage (due to the warm water) overloading this device. This was corrected by the addition of a heat sink to that device. An AXSV is designed to free run at approximately 150HZ in the rare event that the transducer or the high frequency amplifier fail to sense the reflected signal in the ring around the cell. For system number 024, the XSV continued to operate in this free running mode during the entire drop. The cause for the failure is unknown since the probes cannot be recovered for accurate post analysis. Overall, this test showed that this design concept, while needing additional testing, was feasible. Another test was scheduled for December and then postponed until February 4, 1982.

Five AXSV's were manufactured for the final air drop. However, this time the nose weight had been reduced to 542 grams (from 915 grams) and some of the production tooling was available to aid in assembly. During this build there were no assembly problems. This test was also conducted at the Sonobuoy Quality Assurance Facility and the units were launched from a P-3 aircraft at 300 feet by 250 knots. The sea state for this test was a 4 with the wind at 25 knots. Table II shows the results of this test.

Three of the five units were good. Of the two defective units the first unit had a normal air descent, the RF carrier was on frequency and the power level normal. However, after probe release there was no signal from the probe. Since the probe cannot be recovered it was not possible to determine the exact cause of this defect. The second unit which failed had a normal air and water deployment. It had a good probe signal for 1 min 42 sec, however, at that time the RF dropped out for a few seconds twice. After the RF returned, the probe modulation signal was gone. It is believed that the surface unit was washed over either by the wake of the recovery vessel or because of the high sea state (4) and winds (25 knots). This rollover action of the surface unit could cause the BT wire dereeling from the surface to pull at an extreme angle thus breaking the wire.

This test also showed the general design feasibility but again the product reliability desired prior to a production run was not achieved.

TABLE I

<u>SERIAL NUMBER</u>	<u>CHANNEL NUMBER</u>	<u>RESULTS</u>
024	14	Free running transducer
028	14	OK
029	16	RF off at 1.57 after splash down
022	16	OK
025	14	OK

TABLE II

<u>SERIAL NUMBER</u>	<u>CHANNEL NUMBER</u>	<u>RESULTS</u>
28	12	OK-tone life 6 min 48 sec, tone off before end of RF
29	14	OK-tone life 6 min 40 sec, tone off before end of RF
30	16	RF-OK, but no probe tone
31	16	RF-OK, but tone life only 1 min 42 sec
32	14	OK-tone life 6 min 20 sec, tone off before end of RF

SECTION 5

CONCLUSION AND RECOMMENDATIONS

The primary objective of this program was to develop an air launchable Expendable Sound Velocimeter which was compatible with standard sonobuoy launch platforms and receivers. In addition to making this device affordable, it was highly desirable to use AXBT and XSV hardware wherever possible. Both of these objectives were met. However, before this product could go into production it is recommended that additional testing be conducted.

First, in order to verify the probe drop rate which has been developed by extending the AXBT and XSV data it is recommended that an additional drop rate test be conducted either at the NWSC underwater weapons tank or over-the-side comparison drops at sea with a known standard. Second, in order to improve the system's reliability it is recommended that two additional air drop tests be conducted. In the first one the probe would not be allowed to deploy. After water impact the unit would be recovered for a simulated deployment at Sippican. In this way any defective probe could be analyzed for the cause of the defect and the design modified as required. Sippican will fund this test with internal development money and the test will be conducted by the end of March. After this test is completed then additional units should be manufactured and tested to demonstrate overall system performance. Once these two steps are taken the AXSV should be ready for limited production runs.

APPENDIX A

XSV

Expendable Sound Velocimeter

The Sippican XSV facilitates the direct measurement of sound velocity profiles by means of a cost effective expendable device. The XSV will measure sound velocity to an accuracy of ± 25 meters/sec to depths of up to 2000 meters. As with the Sippican XBT's, the XSV may be launched with a minimum of restriction upon ship's speed and maneuvering, providing a significant savings in time, and modernizing the data collection effort.

Today's sophisticated sonars and acoustic navigation systems can provide significantly improved information in many oceanic regions when actual sound velocity profiles are used in lieu of computed S/V values based upon temperature profiles and assumed salinity data.

Knowledge of sound velocity is important to the ASW tactician and physical oceanographer because of the effect that variations in S/V have upon acoustic absorption and refraction. It is in the vicinity of oceanic fronts, polar ice melt, or near coastal areas with large river run off that the most significant variations of sound velocity due to salinity variations will exist. Even in the open ocean, salinity may vary as much as 3 ppt from the average 35 ppt, normally used in sound velocity computations. This can contribute to errors of as much as 4.2 meters per second in computed sound velocity.

By reducing these errors to less than 0.25 meters per second the XSV data can increase the effectiveness of sonar systems by removing a degree of uncertainty from the ASW problem, insure greater accuracy of acoustic positioning systems, and increase our general knowledge of acoustic propagation in the world's oceans.

Applications

Military

ASW — Acoustic prediction and ray path analysis
Data integrated into on board computer systems
Acoustic Propagation Research

Scientific/Commercial

Calibration of Doppler Sonar Systems, fathometers, and Acoustic Positioning Systems

XSV

Probe and Wire Link

The afterbody and wire link used in the XSV are nearly identical to those used successfully in the more than 2,000,000 XBT's manufactured by Sippican. The only real difference in this portion of the probe is in the fact that XSV's require only one transmission wire in the wire link; whereas,

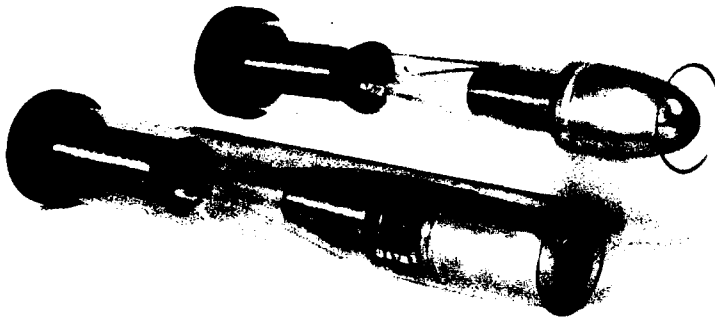

Clear models: XBT (top), XSV (bottom)

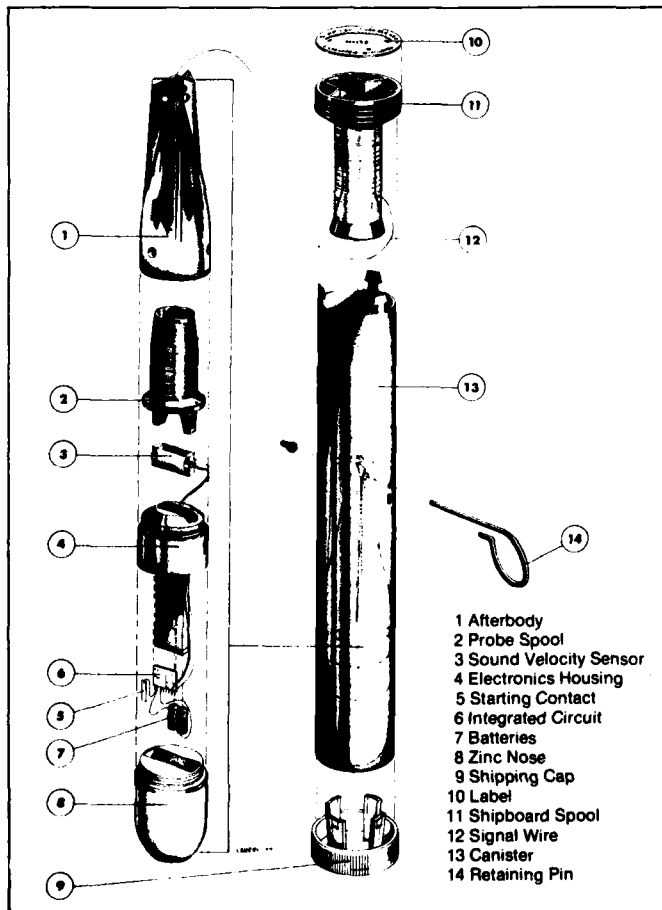

XSV Exploded View

XBT's require two wires, one for each leg of the modified wheatstone bridge used to determine thermistor resistance.

Forward of the afterbody, a 28mm has been inserted as a compartment for housing the sing-around sound velocimeter and associated electronics.

The zinc nose of the XSV is slightly heavier than the standard XBT in order to maintain the proper center of gravity. The nose has also been modified by flattening the front to provide descent stability and by replacing the round water-flow channel of the XBT with a rectangular channel to accommodate the geometry of the sing-around sensor.

Since depth is determined by rate of fall, the total weight is held within a very tight tolerance. The XSV descent characteristic is described by the following expressions where d is depth in meters and t is time in seconds:

$$d = 5.3672t - .001476t^2 \text{ for 850m probe, or}$$

$$d = 5.5895t - .001476t^2 \text{ for 2000m probe}$$

Depth accuracy is $\pm 2\%$ or 5 meters, whichever is greater.

XSV Specifications

Depth XSV-1	850 meters 15 knots
XSV-2	2000 meters 8 knots
System Sound	$\pm .25$ meters/sec.
Velocity Accuracy	
Depth Accuracy	$\pm 2\%$ or 5 meters (whichever is greater)
Dimensions	7cm · 39.5cm
Weight	1.2 kg.
Packaging	12 per case
Shipping Weight Per Case	17.5 kg.

- 1 Afterbody
- 2 Probe Spool
- 3 Sound Velocity Sensor
- 4 Electronics Housing
- 5 Starting Contact
- 6 Integrated Circuit
- 7 Batteries
- 8 Zinc Nose
- 9 Shipping Cap
- 10 Label
- 11 Shipboard Spool
- 12 Signal Wire
- 13 Canister
- 14 Retaining Pin

APPENDIX B

PROBE WEIGHT:

	<u>Dry</u>	<u>Sea Water (P=63.57 lb/FT³)</u>
Nose:	915 gms (P=408 lb/FT ³)	772 gms
Tail:	53.6 gms	1.7 gms
Wire:	55 gms	41 gms
Spool & Front Section Filled:	86 gms	6 gms
TOTAL	1109.6 gms (2.444 lb)	820 gms (1.8077 lb)

FINAL WEIGHT = 779 gms (1.7158 lb)

Assume Drag Coef. is same as new AXBT

$$C_D = 1.081$$

$$A = .028 \text{ FT}^2$$

$$P_{\text{mean}} = 63.57 \text{ lb/FT}^3$$

$$\text{Initial Velocity} = 7.7786 \text{ FT/Sec}$$

$$\text{Final Velocity} = 7.5308 \text{ FT/Sec}$$

$$\text{Weight/FT or Wire (in H}_2\text{O)} = 3.15 \times 10^{-5} \text{ lb/FT}$$

$$\therefore D = D_0 + V_1 T + \frac{1}{2} A T^2$$

$$D_0 = 1.5 \text{ FT}$$

$$V_1 = 7.7786 \text{ FT/Sec}$$

$$A = \frac{dv}{dt}$$

$$v = \sqrt{\frac{2GW(t)}{PC_D A}}$$

$$\frac{dv}{dt} = \frac{1}{2} \frac{2G}{PC_D A} \frac{dw(t)}{dt} \frac{1}{V(t)}$$

$$\frac{dw(t)}{dt} = -3.15 \times 10^{-5} \text{ lb/FT } V(t)$$

$$\Rightarrow A = \frac{1}{2} (-3.15 \times 10^{-5}) \frac{2G}{PC_D A}$$

$$A = -.00052$$

$$\therefore D(t) = 1.500 + 7.77786t - .000260t^2$$

APPENDIX C

PROBE WEIGHT:

	<u>Dry</u>	<u>Sea Water (P=63.57 lb/FT³)</u>
Nose:	542 gms (P=408 lb/FT ³)	457 gms
Tail:	53.6 gms	1.7 gms
Wire:	55 gms	41 gms
Spool & Front Section Filled:	86 gms	6 gms
TOTAL	736.6 gms (1.621 lb)	505 gms (1.1123 lb)

FINAL WEIGHT = 464 gms (1.0220 lb)

Assume Drag Coef. is same as new AXBT

$$C_D = 1.081$$

$$A = .028 \text{ FT}^2$$

$$P_{\text{mean}} = 63.57 \text{ lb/FT}^3$$

$$\text{Initial Velocity} = 6.10758 \text{ FT/Sec}$$

$$\text{Final Velocity} = 5.8486 \text{ FT/Sec}$$

$$\text{Weight/FT or Wire (in H}_2\text{O)} = 3.15 \times 10^{-5} \text{ lb/FT}$$

$$\therefore D = D_0 + V_1 T + \frac{1}{2} A T^2$$

$$D_0 = 1.5 \text{ FT}$$

$$V_1 = 6.10758 \text{ FT/Sec}$$

$$A = \frac{dv}{dt}$$

$$v = \sqrt{\frac{2GW(t)}{PC_D A}}$$

$$\frac{dv}{dt} = \frac{1}{2} \frac{2G}{PC_D A} \frac{dw(t)}{dt} \frac{1}{V(t)}$$

$$\frac{dw(t)}{dt} = -3.15 \times 10^{-5} \text{ lb/FT } V(t)$$

$$\Rightarrow A = \frac{1}{2} (-3.15 \times 10^{-5}) \frac{2G}{PC_D A}$$

$$A = -.00052$$

$$\therefore D(t) = 1.500 + 6.10758 t - .000260 t^2$$

FILMED
5-8