

AD-A113 774

SYSTEMS RESEARCH LABS INC DAYTON OH RESEARCH APPLICA--ETC F/8 17/8
MULTICHANNEL OPTICAL DETECTION SYSTEM.(U)

MAR 82 G L SWITZER

F33615-81-C-2047

UNCLASSIFIED

SRL-3869

AFWAL-TR-82-2030

NL

1 of 1
5/8/82

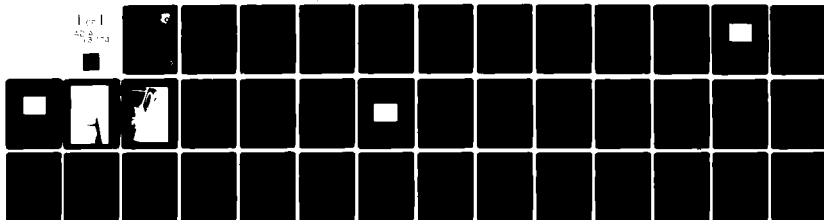

END
DATE
FILMED
5-82
DTIC

AD A113774

12

AFWAL-TR-82-2030

MULTICHANNEL OPTICAL DETECTION SYSTEM



G. L. Switzer

Research Applications Division
Systems Research Laboratories, Inc.
2800 Indian Ripple Road
Dayton, OH 45440-3696

March 1982

Final Technical Report for Period May 15 - December 15, 1981

Approved for public release; distribution unlimited.

AERO PROPULSION LABORATORY
AIR FORCE WRIGHT AERONAUTICAL LABORATORIES
AIR FORCE SYSTEMS COMMAND
WRIGHT-PATTERSON AIR FORCE BASE, OHIO 45433

DTIC
ELECTE
APR 26 1982

E

82 04 26 017

DTIC FILE COPY

NOTICE

When Government drawings, specifications, or other data are used for any purpose other than in connection with a definitely related Government procurement operation, the United States Government thereby incurs no responsibility nor any obligation whatsoever; and the fact that the Government may have formulated, furnished, or in any way supplied the said drawings, specifications, or other data, is not to be regarded by implication or otherwise as in any manner licensing the holder or any other person or corporation, or conveying any rights or permission to manufacture, use or sell any patented invention that may in any way be related thereto.

This report has been reviewed by the Public Affairs Office (PA) and is releasable to the National Technical Information Service (NTIS). At NTIS, it will be available to the general public, including foreign nations.

This technical report has been reviewed and is approved for publication.

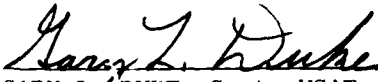
GARY L. DUKE, Capt, USAF
Project Engineer

DONALD P. MORTEL
Actg. Chief, Energy Conversion Br.

FOR THE COMMANDER

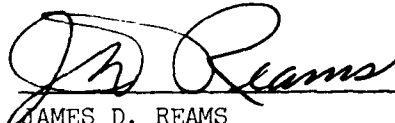
JAMES D. REAMS
Chief, Aerospace Power Division
Aero Propulsion Laboratory

Copies of this report should not be returned unless return is required by security considerations, contractual obligations, or notice on a specific document.

"If your address has changed, if you wish to be removed from our mailing list, or if the addressee is no longer employed by your organization, please notify AFWAL/POOC-3, W-PAFB, OH 45433 to help us maintain a current mailing list."

Unclassified

SECURITY CLASSIFICATION OF THIS PAGE (When Data Entered)

REPORT DOCUMENTATION PAGE		READ INSTRUCTIONS BEFORE COMPLETING FORM
1. REPORT NUMBER AFWAL-TR-82-2030	2. GOVT ACCESSION NO. AD-A113 774	3. RECIPIENT'S CATALOG NUMBER
4. TITLE (and Subtitle) MULTICHANNEL OPTICAL DETECTION SYSTEM	5. TYPE OF REPORT & PERIOD COVERED Final Report May 15 - December 15, 1981	
7. AUTHOR(s) G. L. Switzer	6. PERFORMING ORG. REPORT NUMBER 3869 Final	
9. PERFORMING ORGANIZATION NAME AND ADDRESS Research Applications Division Systems Research Laboratories, Inc. 2800 Indian Ripple Road, Dayton, OH 45440-3696	8. CONTRACT OR GRANT NUMBER(s) F33615-81-C-2047	
11. CONTROLLING OFFICE NAME AND ADDRESS Aero Propulsion Laboratory (POOC) Air Force Wright Aeronautical Laboratories (AFSC) Wright-Patterson Air Force Base, OH 45433	10. PROGRAM ELEMENT, PROJECT, TASK AREA & WORK UNIT NUMBERS Task 2301 Project S1 Work Unit 63	
14. MONITORING AGENCY NAME & ADDRESS (if different from Controlling Office)	12. REPORT DATE March 1982	13. NUMBER OF PAGES 39
	15. SECURITY CLASS. (of this report) Unclassified	15a. DECLASSIFICATION/DOWNGRADING SCHEDULE
16. DISTRIBUTION STATEMENT (of this Report) Approved for public release; distribution unlimited.		
17. DISTRIBUTION STATEMENT (of the abstract entered in Block 20, if different from Report)		
18. SUPPLEMENTARY NOTES		
19. KEY WORDS (Continue on reverse side if necessary and identify by block number) Multichannel Optical Detection, Short Pulsed Spectral Detection, Photomultiplier Detection of Single-Pulsed Spectra, Fiber-Optic Faceplate, Dynamic-Range Enhancement of Pulsed Spectral Detection, Wavelength-Time Conversion Using Fiber-Optic Delay.		
20. ABSTRACT (Continue on reverse side if necessary and identify by block number) A multichannel optical detection system (MODS) for use in the detection of spectral information contained within a short pulsed light event has been developed. The system is based upon a technique which employs a series of fiber-optic waveguides to separate temporally the various spectral components of a light pulse, thus allowing spectral information to be detected by one (or a relatively small number of) photomultiplier tube(s) (PMT). The impetus for the development of this technique was the prospect of a		

Unclassified

SECURITY CLASSIFICATION OF THIS PAGE(When Data Entered)

cost-effective multichannel optical detector having the speed, sensitivity, range, and other advantages inherent in photomultiplier detection.

Unclassified

SECURITY CLASSIFICATION OF THIS PAGE(When Data Entered)

FOREWORD

This final report was prepared by the Research Applications Division of Systems Research Laboratories, Inc., 2800 Indian Ripple Road, Dayton, OH 45440, under Contract No. F33615-81-C-2047, Project 2301, Task S1, Work Unit 63, with Capt. Gary L. Duke (AFWAL/POOC-3) as Government Project Monitor. The technical effort described in this report was accomplished during the period 15 May 1981 through 15 December 1981 and was conducted by Mr. Gary L. Switzer, Mr. David W. Stefanovsky, and Mr. Matthew A. Thomas. The efforts of Mrs. Marian M. Whitaker, Mrs. Helena L. Henrich, and Mrs. Wilma J. Poff in preparation of report material are gratefully acknowledged.

Accession For	
NTIS GRA&I	<input checked="" type="checkbox"/>
DTIC TAB	<input type="checkbox"/>
Unannounced	<input type="checkbox"/>
Justification	
By _____	
Distribution/	
Availability Codes	
Dist	Avail and/or Special
A	



TABLE OF CONTENTS

<u>SECTION</u>		<u>PAGE</u>
I	INTRODUCTION	1
II	MULTICHANNEL-OPTICAL-DETECTION SYSTEM DEVELOPMENT	2
	12-CHANNEL SYSTEM	2
	100-CHANNEL SYSTEM DESIGN	16
	Fiber-Optic-Faceplate Configuration	22
III	CONCLUSIONS	25
	REFERENCES	27
	APPENDIX A - ELECTRONICS MODULES	28

LIST OF ILLUSTRATIONS

<u>FIGURE</u>		<u>PAGE</u>
1	Diagram of Multichannel Optical Detection System (MODS)	3
2	Photomultiplier Output with 12-Channel Input	4
3	ADC Analog (Upper) and Gate (Lower) Signals	6
4	(a) MODS Electronics Components	7
	(b) MODS Optical Components	8
5	Single-Shot Spectrum Obtained at 5000 Å	10
6	Single-Shot Representation of Zero-Order Spectrum	11
7	Nanolamp Temporal Response, 50 ns/Div.	12
8	Attenuation Characteristics of the Optical Fiber	13
9	100-Channel-System Configuration	18
10	Faceplate-Array-Element Construction	23

SECTION I

INTRODUCTION

A multichannel optical detection system (MODS) for use in the detection of spectral information contained within a short pulsed light event has been developed. The system is based upon a technique which employs a series of fiber-optic waveguides to separate temporally the various spectral components of a light pulse, thus allowing spectral information to be detected by one (or a relatively small number of) photomultiplier tube(s) (PMT). The impetus for development of this technique was the prospect of a cost-effective multichannel optical detector having the speed, sensitivity, range, and other advantages inherent in photomultiplier detection. A small-scale version of this system consisting of 12 discrete channels has been assembled and operated. This 12-channel prototype was used to demonstrate the feasibility of the detection-system concept. Knowledge gained in the development of this system has been applied to the design of a practical-scale system consisting of 100 separate channels.

SECTION II

MULTICHANNEL-OPTICAL-DETECTION SYSTEM DEVELOPMENT

12-CHANNEL SYSTEM

The MODS concept, as developed for the 12-channel system, is shown in Fig. 1. A Xenon Corporation Model 437 A Nanolamp is used to provide an optical pulse of ≈ 20 ns FWHM duration. A portion of the energy produced by this source is dispersed within a spectrometer into its component frequencies. The spectrum of frequencies thus produced is imaged at the exit port of the spectrometer onto the face of an array of fiber-optic waveguides. The array is constructed of a linear stack of 12 all-silica, step-index fiber-optic waveguides, each fiber having a 65- μ m-diam. core surrounded by a cladding which results in an overall fiber diameter of 100 μ m. Each of the 12 fiber "channels" is cut to a different length ranging between 3 m and 168 m in steps of 15 m. Since the transmission of light through the fibers is delayed (due to the refractive index of the fiber) by ≈ 5 ns/m, the light entering the various channels of the array will, upon exiting, be separated temporally by 75 ns. Each optical pulse in the series exiting the array contains intensity and frequency (i.e., spectral) information. This series of optical pulses is converted into a series of electrical pulses by an EMI D551 Photomultiplier. A PMT output involving all 12 channels is shown in Fig. 2.

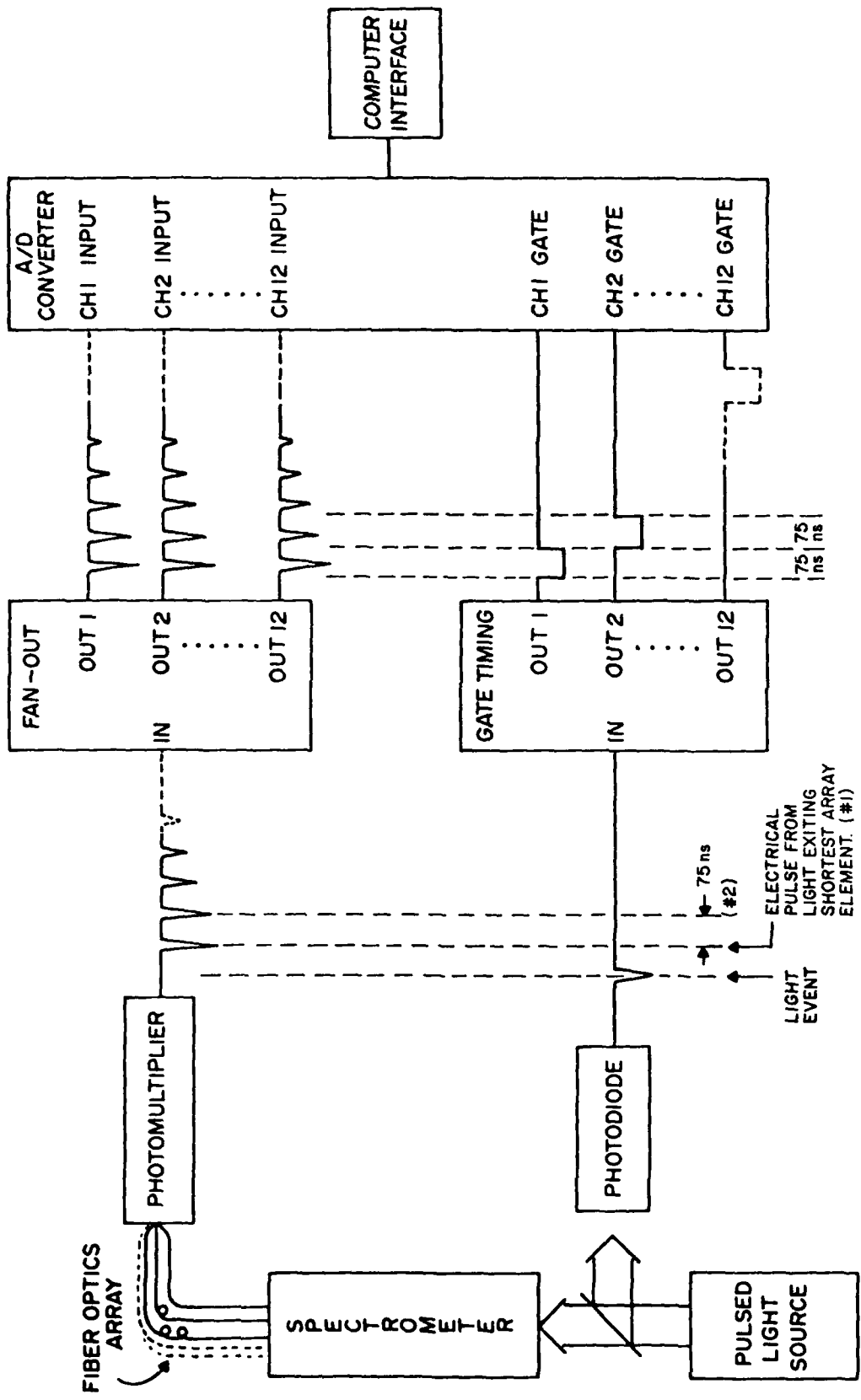

Figure 1. Diagram of Multichannel Optical Detection System (MODS).

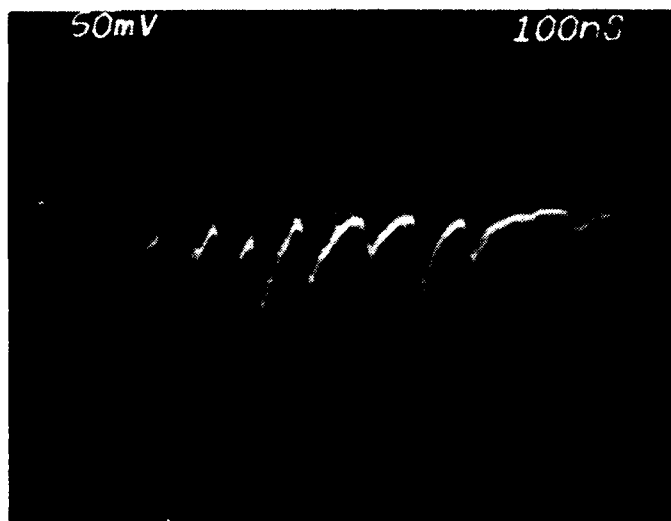

Figure 2. Photomultiplier Output with 12-Channel Input.

In order to isolate any one of the 12 pulses in the series within the 75-ns separation period, it is first necessary to reproduce the pulse train 12 times. This is accomplished using a LeCroy Research Systems Model 428F Quad Linear Fan-Out Module. Each of these identical pulse trains is then applied to separate analog inputs of a LeCroy Model 2249 SG Analog-to-Digital Converter (ADC). Since each of the 12 ADC channels in this module must be gated into operation by means of a separate gate signal, the pulse within the analog pulse train which is digitized in a given ADC is determined by the timing and duration of its gating pulses. Figure 3 demonstrates the relationship between the analog and gate signals for two successive channels. The proper timing and shaping of the gate signals is accomplished by gate-timing module which is triggered by the pulsed light event through a PIN photodiode which senses a portion of the lamp output.

Once the 12 channels have been digitized, they are transferred via a computer interface into an Apple II Plus Computer System where the data are analyzed and stored on floppy diskettes. The electronic and optical components of the completed system are shown in Fig. 4. Although the detection electronics of this system are capable of up to 20-KHz repetition rates, the rate of data collection was limited to ≈ 3 Hz by the capability of the input/output interface of the computer. This interface slowed operation by requiring the driving software to be written in BASIC language and further by requiring multiple reads to transfer the 11-bit ADC output through the 8-bit parallel interface. The gate-timing and computer interface modules which were fabricated to complete the required system electronics are documented in Appendix A.



Figure 3. ADC Analog (Upper) and Gate (Lower) Signals.

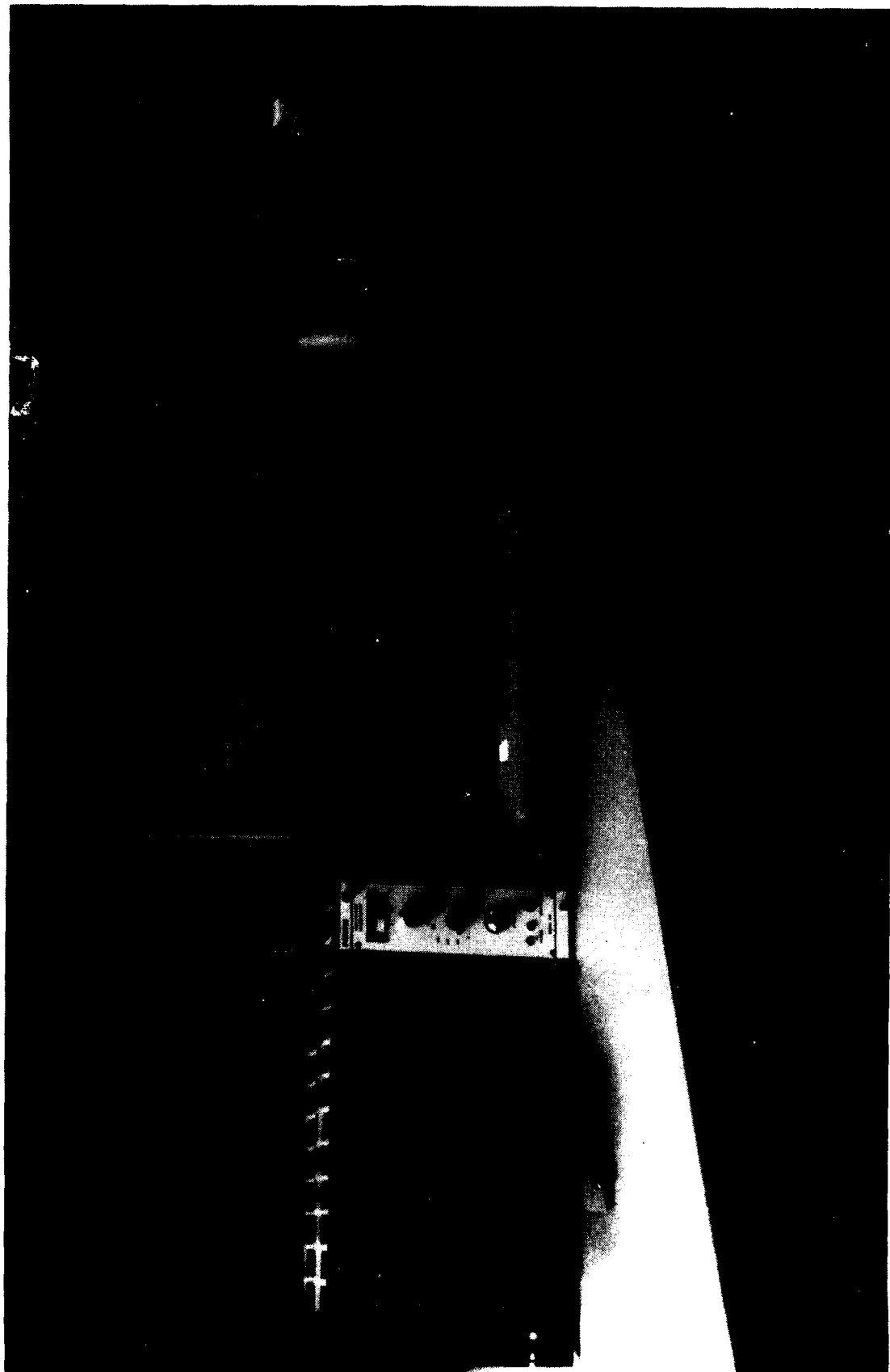

Figure 4(a). MODS Electronics Components.



Figure 4(b). MODS Optical Components.

The ability of the system to capture a single pulsed spectrum is demonstrated in Fig. 5. This spectrum obtained (through the $\approx 15\text{-}\overset{\circ}{\text{A}}$ spectral window created as a result of the array dimension) near $5000\ \overset{\circ}{\text{A}}$ shows some structure existing in a broad low-level continuum. The ability to demonstrate system operation at other well-defined wavelengths was limited due to the spectral content of the available pulsed-light source. Since the air-gap spark of the nanolamp produces a characteristic output confined primarily to ultraviolet wavelengths below $4000\ \overset{\circ}{\text{A}}$, no prominent spectral lines were found which could be efficiently transmitted within the 4500 to $8000\ \overset{\circ}{\text{A}}$ useful operating range of the optical fibers. A more highly resolved, single-pulse spectral line is simulated in Fig. 6. In this plot the apparent spectrum is the zero-order throughput of the spectrometer, the width being controlled by the setting of the entrance slit. The effect of another unwanted characteristic of the nanolamp source is evident from this figure. The temporal response of this source is illustrated in Fig. 7. Here the pulse duration is $\approx 20\ \text{ns}$ FWHM. The problem caused by this pulse comes about because of the slow decay in its trailing edge which, for a relatively intense pulse such as that in Fig. 6, does not return to zero within the 75-ns pulse-separation period. Thus, some of the energy contained in an intense channel is integrated along with the pulse of the subsequent channel and appears as interchannel crosstalk. This effect can, of course, be eliminated either by employing a shorter-duration light source with a faster turn-off time or by increasing the optical delay between successive channels.

One undesirable aspect which was discovered in the system performance is related to the attenuation characteristics of the optical fibers. These characteristics are shown in Fig. 8 for the Quartz Products Corporation Med

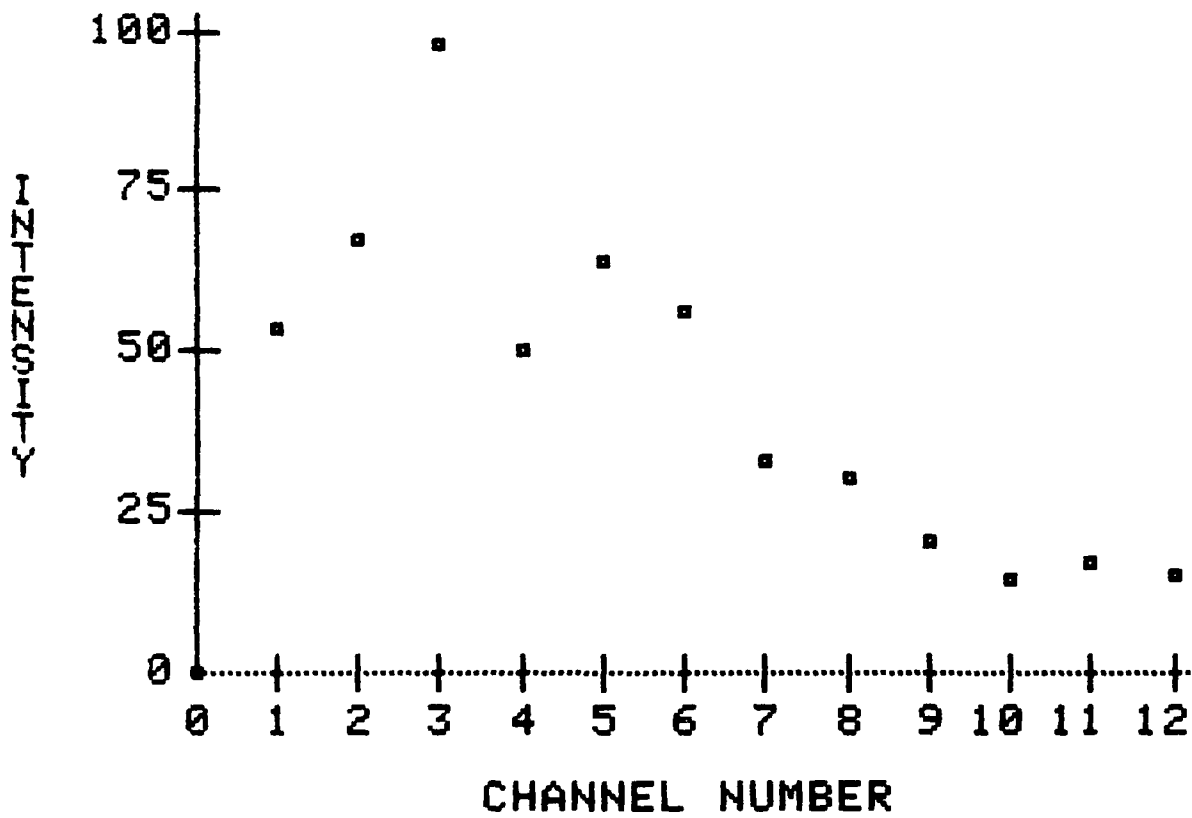

Figure 5. Single-Shot Spectrum Obtained at 5000 Å.

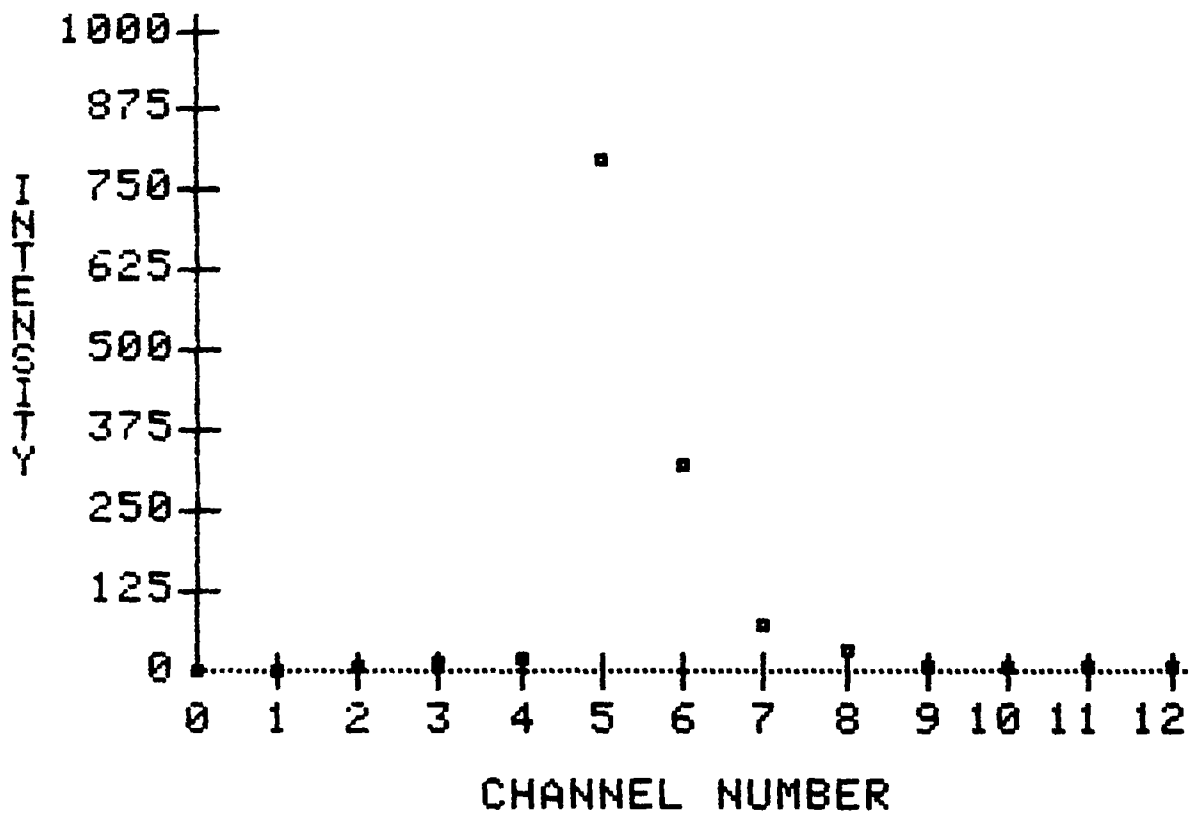

Figure 6. Single-Shot Representation of Zero-Order Spectrum.

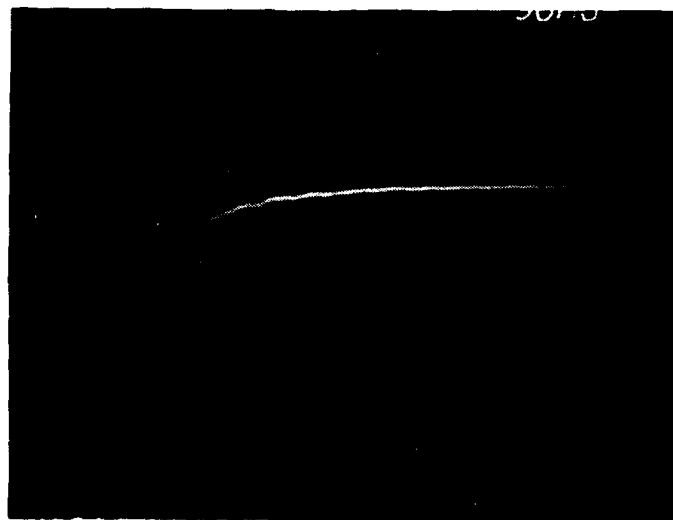

Figure 7. Nanolamp Temporal Response, 50 ns/Div.

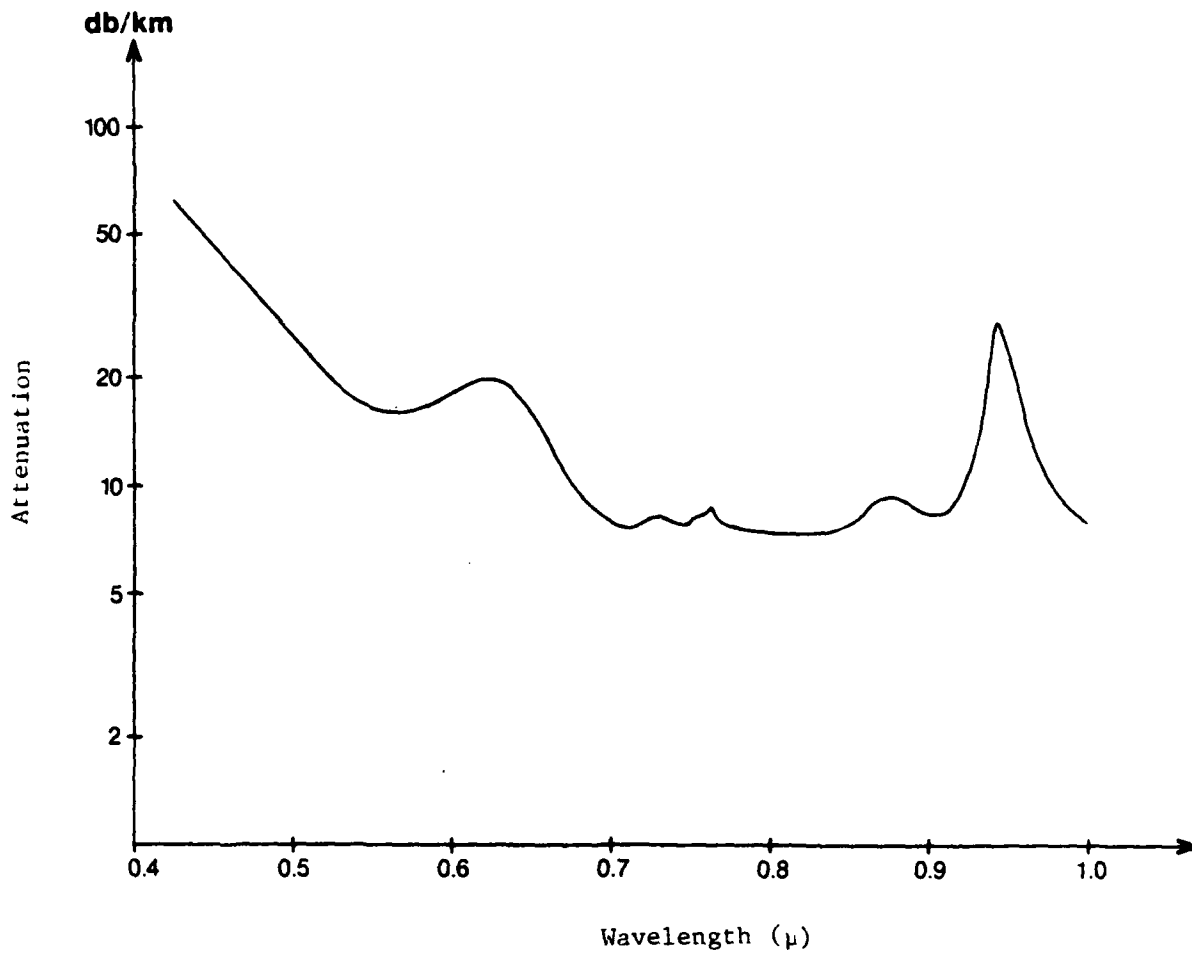

Figure 8. Attenuation Characteristics of the Optical Fiber.

65 Fibers incorporated in the fiber-optic array. The transmission losses within these fibers are sufficiently high (especially below 5000 \AA) that the optical losses between the successive channels may become significant due to the incremented length of each fiber. Based upon the $\approx 25\text{-dB/km}$ attenuation exhibited by these fibers during a 5000-\AA operation, one can anticipate a factor-of-three relative reduction in optical signal between the first and twelfth channels at this wavelength.

The relative channel losses induced by the fiber transmission have the most pronounced effect upon the dynamic-range capability of the ADC; this effect is illustrated as follows. If the array were to be uniformly illuminated, a signal-to-noise consideration would require that a minimum of, for instance, 20 ADC counts (assuming a 15-count background) be observed from the channel indicating the lowest intensity. If a factor-of-three loss in optical signal between the first and twelfth channel were assumed, then the highest intensity channel would result in three times these 20 counts or 60 counts. While the available dynamic range of each individual channel would be 20 to 1024 counts (dynamic range = 64), the usable combined range before saturation of the strongest channel would be 60 to 1024 counts (i.e., dynamic range = 17). Thus, the already limited dynamic range of the 10-bit, 0-256 pC ADC is considerably reduced. Unfortunately, since this rather large limitation in the usable range is experienced within the ADC, its effect would be reflected in the digital data output. Therefore, the calibration factors necessary to provide suitable compensation could not be provided by a simple "channel constant" administered within the computer-system software (i.e., once the ADC saturates to 1024 counts, its output cannot be corrected by a multiplicative

constant). A solution to this problem involves selective amplification of the electronic pulses applied to the ADC analog input, with the weaker signal channels being amplified by the proportionate loss experienced in their respective optical-input fibers. Thus calibrated, the system digital output profile could be made identical to the optical profile at the array input.

The cost to overall system performance due to this problem and its solution is decreased system sensitivity. However, the photomultiplier detection used in this system typically exhibits a sensitivity advantage of 10^3 to 10^4 over the solid-state diode detection presently employed in commercially available optical multichannel analyzers. Thus, even with a factor-of-ten decrease in system sensitivity, the present 12-channel system continues to offer a distinct improvement in optical-detection sensitivity.

Through operation of the 12-channel MODS, the feasibility of the MODS detection concept was demonstrated. Questions concerning its operation--such as whether the critical signal-timing conditions for gating waveforms could be met and held, whether sufficient optical delay could be obtained efficiently, and whether the closely spaced electrical signals could be treated individually--were answered; potential problem areas were identified; and means for their correction were developed.

100-CHANNEL SYSTEM DESIGN

A second phase of this program involved the design of an expanded version of the system to include 100 optical-input channels. Throughout the system-design process, several general system criteria were considered. Among them were optimizing parameters such as dynamic range and speed of operation, using commercially available components to demonstrate capabilities obtainable with existing technology, and keeping system cost to a minimum.

Since optimization of the usable dynamic range is one of the most important goals of this system, the capability of the photomultiplier in this respect is ultimately the limiting factor. The manufacturer's specification data¹ indicate that the fastest response and highest current-handling capabilities can be obtained with a linear focused PMT structure employing BeCu dynodes. With this type of tube, peak output currents of 25 mA can be obtained, while the tube response remains within 2% of linear. On the low end of the current scale, the minimum usable output of the tubes is determined by the current produced by a single photoelectron being emitted from the photocathode. This current can be calculated using the following expression:

$$i = \frac{q_e A}{t} \quad (1)$$

where i is the instantaneous output current, q_e the electronic charge, A the PMT gain, and t the pulse width (FWHM). When the typical values of $q_e = 1.6 \times 10^{-19}$ C, $A = 3 \times 10^5$, and $t = 10$ nsec are applied to Eq. (1), a lower limit of 4.8 μ A is estimated. Thus, the maximum linear operation which one can expect from such a tube is 25 mA/4.8 μ A or ≈ 5200 .

If one defines the dynamic range of the system to be ≈ 5000 , based upon the PMT limitation, selection of the necessary electronic components can be accomplished. The components necessary for the proposed design configuration are diagrammed in Fig. 9. This configuration was developed based upon 10 channels of the 100 fiber-optic inputs being detected by a single PMT, requiring a total of ten PMT's. The basis for this 10-channel/PMT configuration will be discussed presently. Each path from optical input to digital output encounters the following sequence of events. The first 10 fiber-optic array elements are detected by an EMI 9882B Photomultiplier Tube. The series of electrical pulses generated is reproduced in a LeCroy Research Corporation Model 428F Linear Fan-Out, and each reproduced pulse train is applied to a separate Datel SHM-UH3 Sample-Hold (S/H) Integrated Circuit. The logic which controls the sample or holding mode of the S/H is controlled via a pin-diode/sample-timing configuration similar to that described earlier for the 12-channel MODS. The channel peak intensity stored by the S/H is then routed via a Datel MV-1606 Analog Multiplexer through a LeCroy Research Corporation 612 AM Variable Gain Amplifier and finally digitized in a Datel Model ADC-817 MC. This final component, a 12-bit ADC with a 2- μ sec conversion time and a 1.2-mV/bit resolution, provides full compatibility with the dynamic-range capability of the photomultiplier.

With these components serving as an indication of the type and configuration of the necessary electronics, an estimation can be made concerning the optimum number of fiber-optic channels which should be detected per PMT. Two possible criteria for making this decision were considered. First, with regard only to transmission losses in the optical fiber, one could continue adding longer fibers into one PMT channel until the light transmitted by the

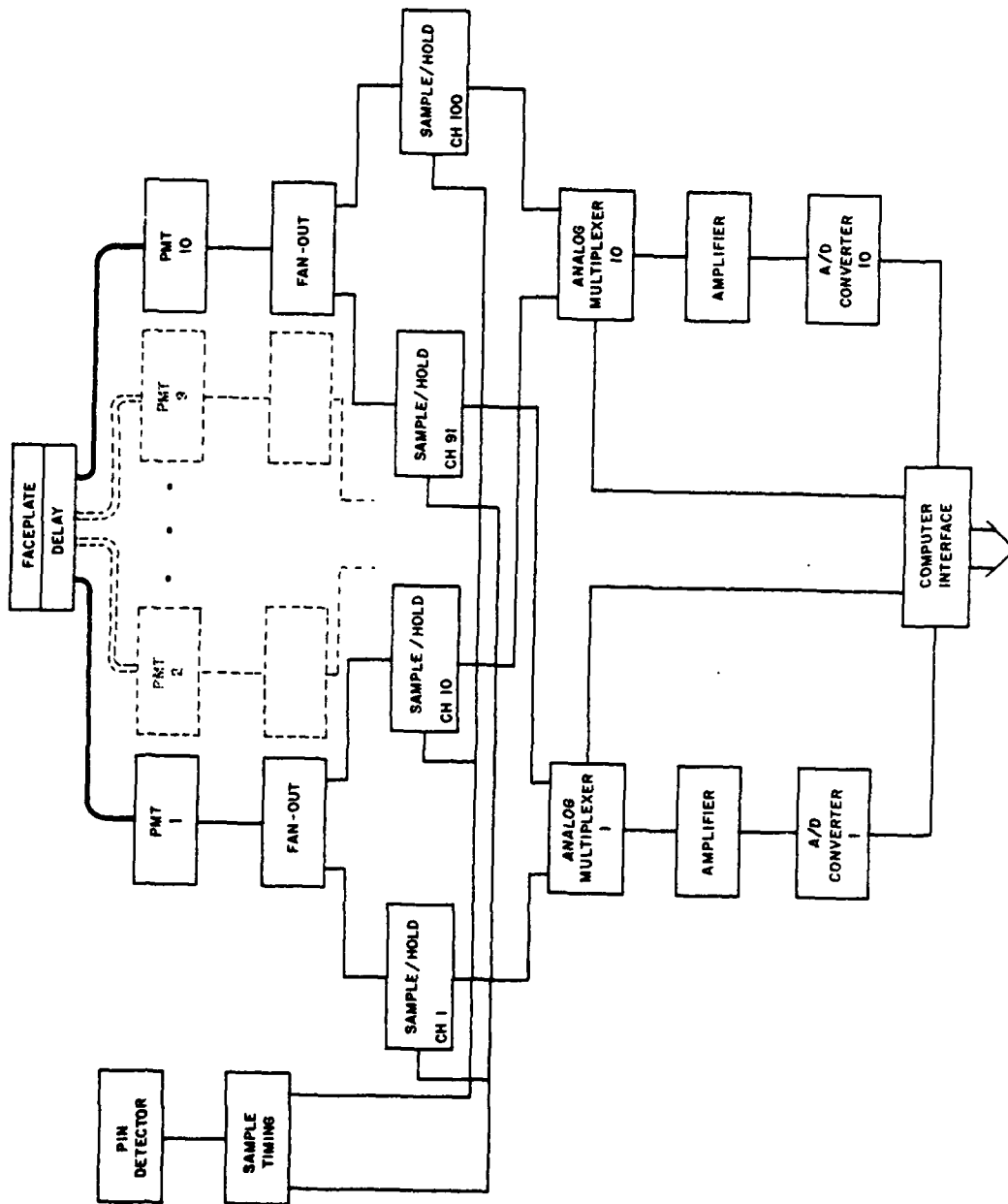

Figure 9. 100-Channel-System Configuration.

longest fiber fell below some lower limit (e.g., 10%). Second, the relative costs of the optical fiber and the electronics necessary to condition the optical output from a single fiber are compared. Since cost efficiency is a major criterion in this design effort, the second analysis method was used. On the basis that the breakeven point (in weighing the cost of fiber vs. the cost of electronics) occurs when the cost of adding an additional fiber to a "bundle" equals or exceeds twice the cost of the conditioning electronics required, the following formulae were developed:

$$2 \left(\frac{\text{PMT C}}{N} + \frac{\text{FOC}}{N} + \frac{\text{MUXC}}{N} + \frac{\text{AMPC}}{N} + \frac{\text{ADC}}{N} + \frac{\text{PSC}}{N} \right) = \ell (\text{CPM}) \quad (2)$$

$$\text{where } \ell = 1 + (N-1) \frac{t_d}{5 \text{ ns/m}} \quad (3)$$

The factors on the left side of Eq. (2) involve only those proportionate equipment costs which will be affected by the number of fibers/PMT chosen. Definition of the variables in these equations and an estimate of their value is as follows: N represents the number of the fiber channel in which the total cost of the fiber is equal to twice the cost of one channel of electronics; PMTC is PMT cost = \$390; FOC is fan-out cost = \$100; MUXC is analog multiplexer cost = \$20; AMPC is amplifier cost = \$140; ADC is analog-to-digital converter cost = \$290; PSC is power supply cost = \$150; ℓ is length of an individual fiber, CPM is cost per meter of fiber = \$1; and t_d is optical delay time between successive fibers = 100 nsec. When these values are used in Eq. (2), $N = 10.9$ results. Thus, 10 fiber-optic channels per photomultiplier will provide the most efficient balance in these component costs.

Some of the important characteristics of the fiber-optic delays to be employed in this system are listed in Table 1. The length increment of 20 m suggested in the table was chosen to provide 100 nsec of separation to lessen possible interchannel crosstalk effects. The stated transmissions of this table include an estimate of 8% loss due to optical coupling into and out of the fiber.

The last two columns of Table 1 (relative loss and normalizing amplification) indicate the extent of inter-channel optical losses and the amounts of selective amplification required to compensate for them in such an optical configuration. The problem of incorporation of the required selective amplification into the system design in a practical and convenient manner can be solved by the design of the segment of the electronics configuration shown in Fig. 9 consisting of analog multiplexer, amplifier, and ADC. The use of the multiplexer reduces the number of electronic channels required. More importantly, it allows the fiber optics of identical length from each input delay bundle to be routed through a common amplifier. Thus, only 10 amplifier settings must be recalibrated for a change of system operating wavelength.

Although further use of multiplexers could reduce the number of ADCs required, each electronic channel is terminated in its own ADC for two reasons. To obtain the fastest system repetition rates, ten 2- μ s-digitization-time ADC's operating in parallel were desired. The other constraint also requiring high-speed conversion is that the digitization process be completed before the hold-mode droop characteristic (50 μ V/ μ sec.) of the S/H results in significant signal degradation. The anticipated

TABLE 1

Characteristics of Fiber-Optic Delays for 5000-Å Operation

Channel No.	Length (m)	Transmission (%)	Relative Loss	Normalizing Amplification
1	1	91.4	1.0	1.0
2	21	80.6	1.1	1.1
3	41	71.0	1.3	1.1
4	61	62.4	1.5	1.5
5	81	54.7	1.7	1.7
6	101	47.9	1.9	1.9
7	121	41.8	2.2	2.2
8	141	36.4	2.5	2.5
9	161	31.6	2.9	2.9
10	181	27.3	3.4	3.4

Total Length = 910 m

characteristics of the configuration design include a repetition rate of 33 kHz through the ADC, with the hold-mode droop resulting in a possible signal loss of one 1.2-mV count.

Fiber-Optic-Faceplate Configuration

Another important consideration in the development of a practical system based upon the MODS concept is the efficiency with which the pulsed optical spectral energy can be collected and channeled into the detection system. Ideally, it is desirable for the face of an optical input channel to be sufficiently narrow in one dimension to provide good frequency resolution (in conjunction with the dispersive power of the spectrometer) and sufficiently long in the other dimension to allow the full size of the imaged source to be intercepted. In addition, maximum acceptance of the light incident upon this face is desirable. Given these input characteristics, an array could be constructed by stacking 100 such elements together to form a "faceplate" which would greatly enhance the overall system sensitivity.

Since the circular cross section presented by individual optical fibers cannot provide the desired profiles stated above, some configuration other than a linear stack of separate fibers is required to permit the most efficient operation. Based upon present manufacturing capabilities in this area,^{2,3} one possible design configuration for a more efficient faceplate element is that shown in Fig. 10. The element described here is composed of a close-packed stack of 6- μ m-diam. optical fibers with a core-to-cladding ratio which can provide coupling efficiencies of \approx 90-95%. Once the stack

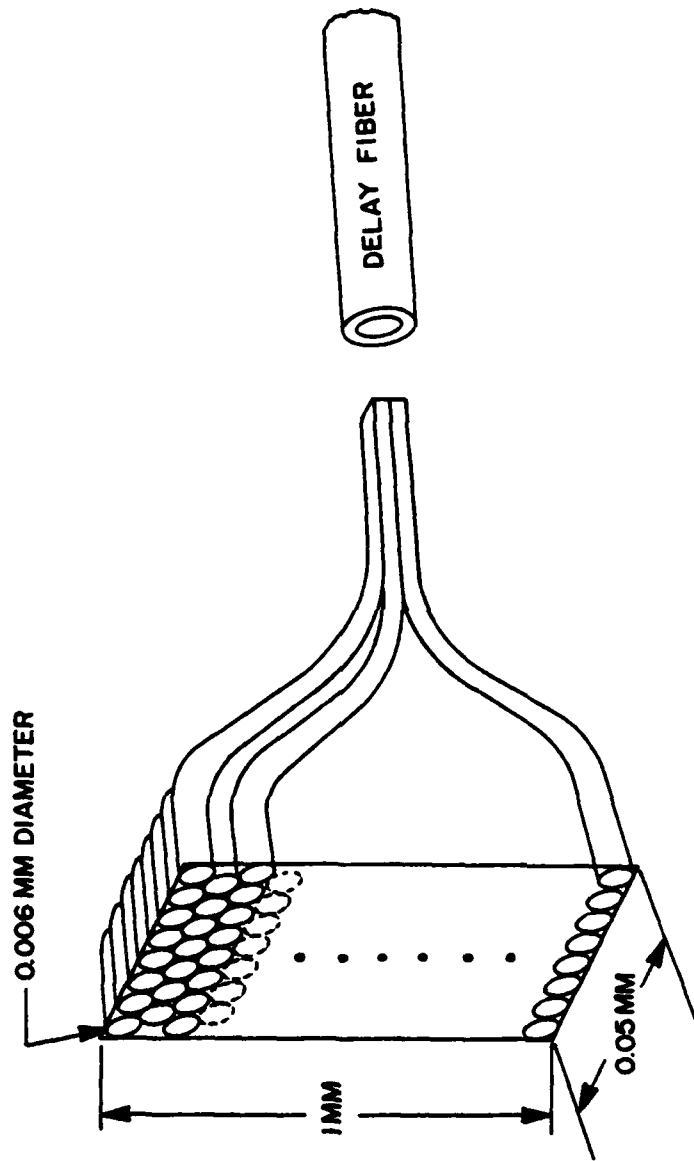

Figure 10. Faceplate-Array-Element Construction.

is formed, the claddings of the individual fibers are fused to form a "fiber-optic ribbon" which is essentially void of interstitial spaces; as a result, the overall coupling efficiency of the polished rectangular face can reach an estimated 90%.

After light has been intercepted by the faceplate element, it must be delayed as described earlier. In order to accomplish this delay in a practical manner, it is desirable that the actual single fiber performing the delay be relatively inexpensive and possess sufficient transmission characteristics for the necessary long delays. The transition from the rectangular faceplate element to such a circular delay fiber can be accomplished as indicated in Fig. 10. The fiber-optic ribbon can be drawn in such a way that its output end is reduced to a rectangular cross section whose diagonal dimension is the same as the diameter of the desired delaying fiber optic. When both of these surfaces are polished, they can be epoxied together with less than 5% coupling losses. An unfortunate consequence of drawing the ribbon in order to condense the optical input into the delay fiber is that each of the 6- μ m fibers takes on a tapered fiber geometry. The result of this gradual change in geometry is that higher transmission losses (40-50%) will be incurred. The resultant coupling efficiency from the array face to the delay fiber optic can be estimated to be \approx 50%. The ultimate effect of this loss (as was the case for inter-channel fiber losses) is decreased system sensitivity. However, as stated previously, the sensitivity advantage gained by PMT detection more than makes up for these losses.

SECTION III

CONCLUSIONS

The feasibility of a concept for the detection of the spectral content of short-pulsed optical events employing fiber-optic delays and photomultiplier detection has been demonstrated. Some important operational characteristics of a practical scale system designed to incorporate the technique are summarized in Table 2. Although further refinements in the electronic and optical components design of a 100-channel system can be made, the sample designs described here could be implemented with a high degree of confidence that the resultant system would offer significant operational advantages over similar systems presently employed for multichannel optical detection.

TABLE 2

Summary of 100-Channel-System Characteristics

<u>Parameter</u>	<u>Value</u>	<u>Notes</u>
Wavelength Range	4500-7000 Å	Short end limited by fiber optics; long end limited by PMT response.
Event Duration (Upper Limit)	10 ns FWHM	Near-Gaussian pulsed event.
Inter-Channel Temporal Separation	100 ns	
Number of Channels/PMT	10	Optimum number based upon cost efficiency.
Linear Dynamic Range	5000	Limited by photomultiplier capability.
Repetition Rate	33 kHz	Excluding computer acquisition time.
Sensitivity	40 photons/output count	Assuming 5000-Å operation.
Faceplate-Coupling Efficiency	50%	Preliminary estimate.
Approximate Cost per Channel	\$506	Excluding computer system.

Cost Estimate Basis

Item	Unit Cost	Quantity	Cost
PMT	500	10 ea	5000
Fan-Out	600	9 ea	5400
Multiplexer	20	10 ea	200
Amplifier	1000	2 ea	2000
A/D Converter	290	10 ea	2900
Power Supply	300	10 ea	3000
Sample/Hold	210	100 ea	21000
Fiber Delay	\$1/m	9100 m	9100
Fiber Faceplate	2000 (est)	1 ea	2000
		Total	50,600

2

REFERENCES

1. Photomultiplier Operation and Application Catalog, (EMI Gencom, Inc., Planview, NY, 1979).
2. Private communication with Mr. Richard Mead, Collimated Holes Inc., 4600 Division St., Campbell, CA 95008.
3. Private communications with Mr. Albert Tuttle, HSS, Inc., 2 Alfred Circle, Bedford, MA 01730.

2.

APPENDIX A
ELECTRONICS MODULES

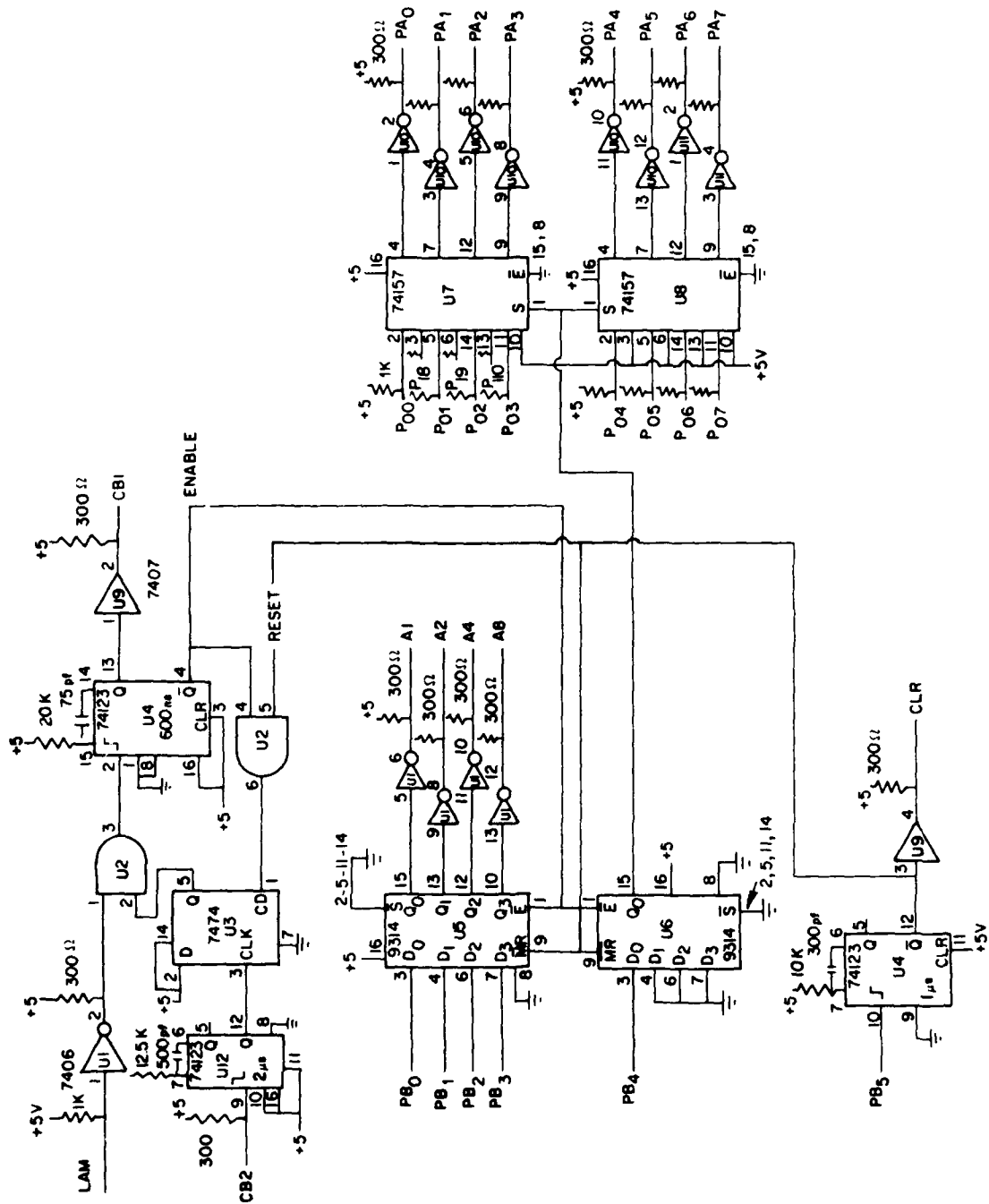

Figure A1. Computer-Interface-Module Schematic.

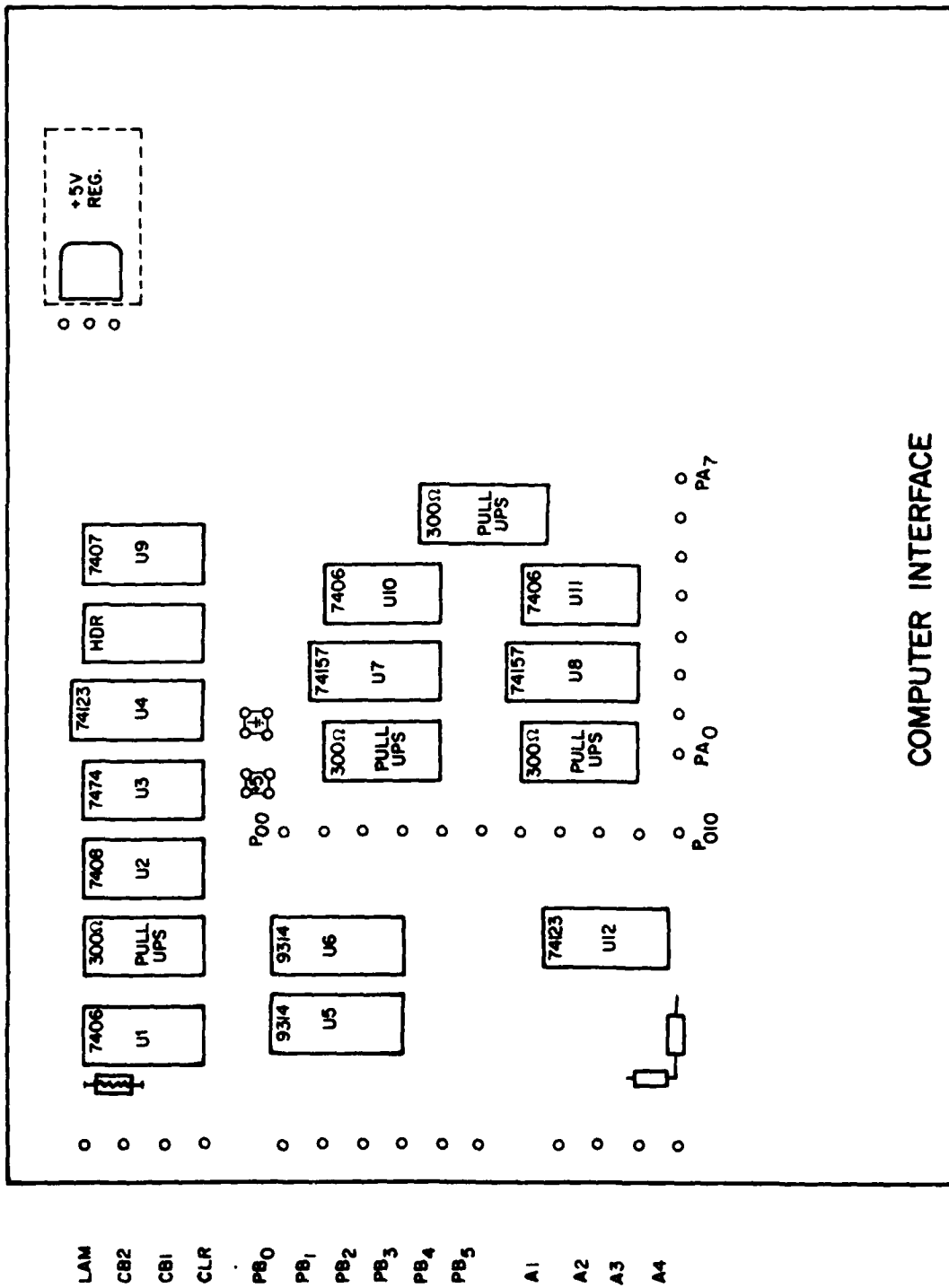

Figure A2. Computer-Interface-Module Board Lay-Out.

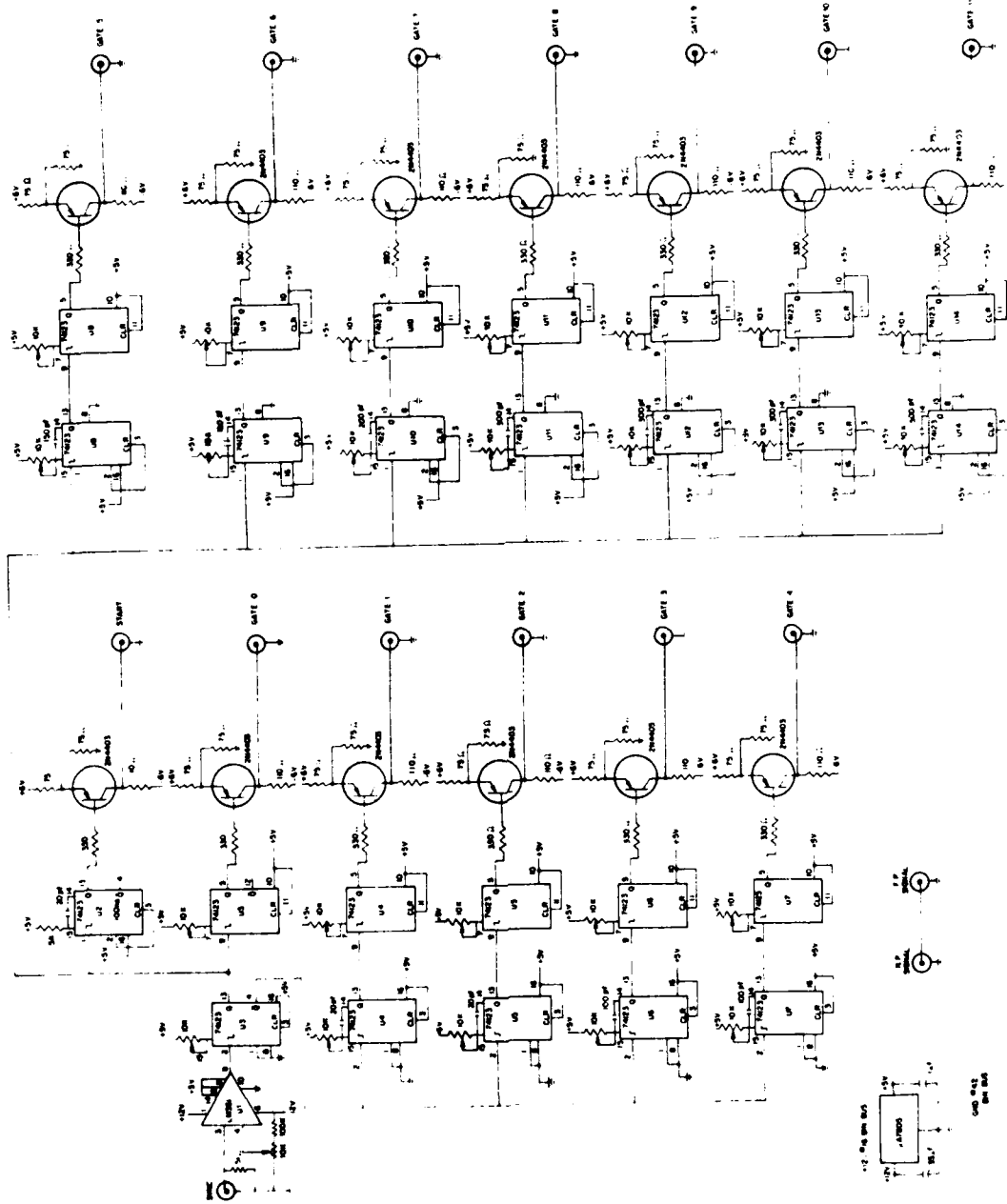

Figure A3. Gate-Timing-Module Schematic.

Copy available to DTIC does not permit fully legible reproduction

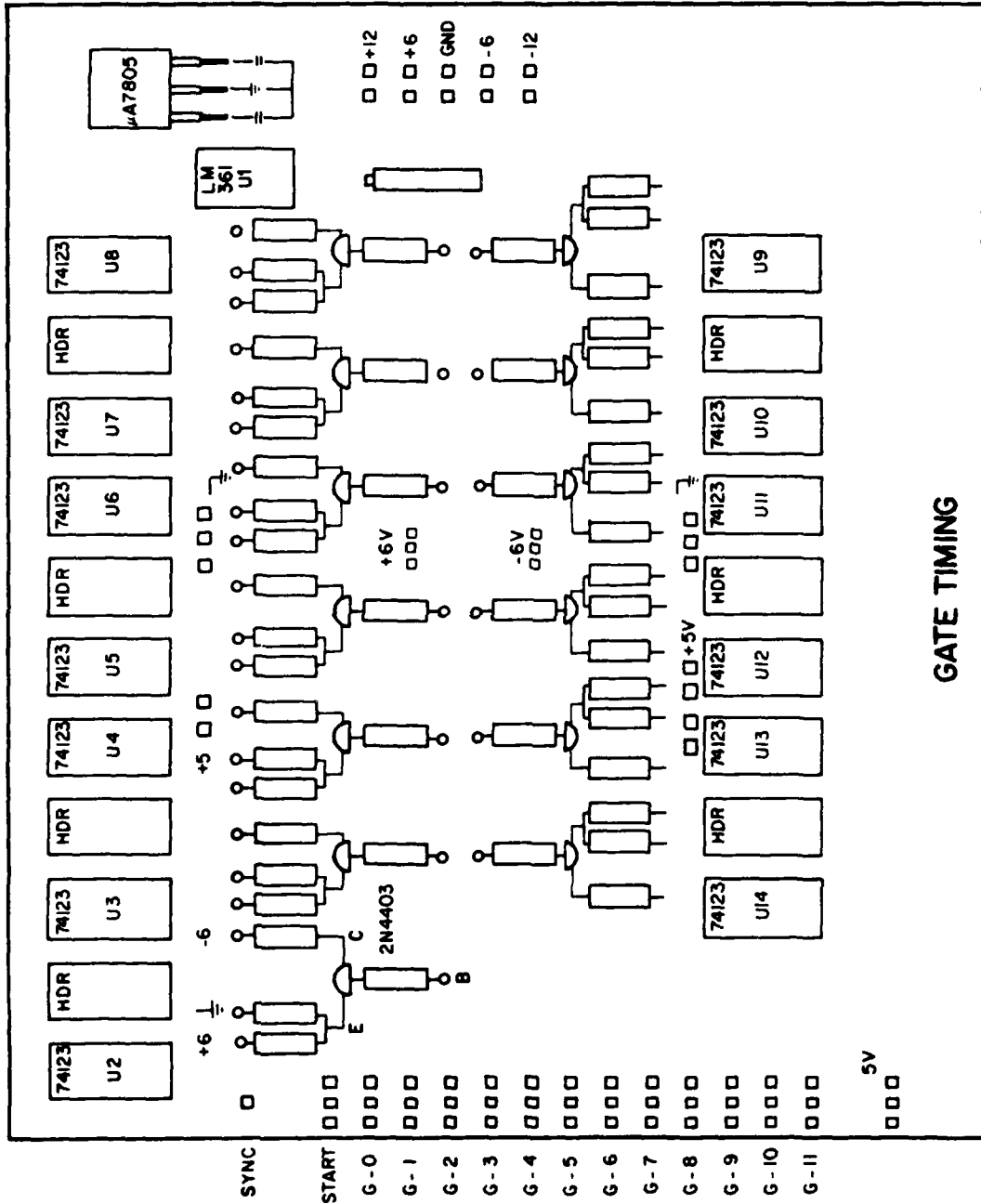

Figure A4. Gate-Timing-Module Board Lay-Out.

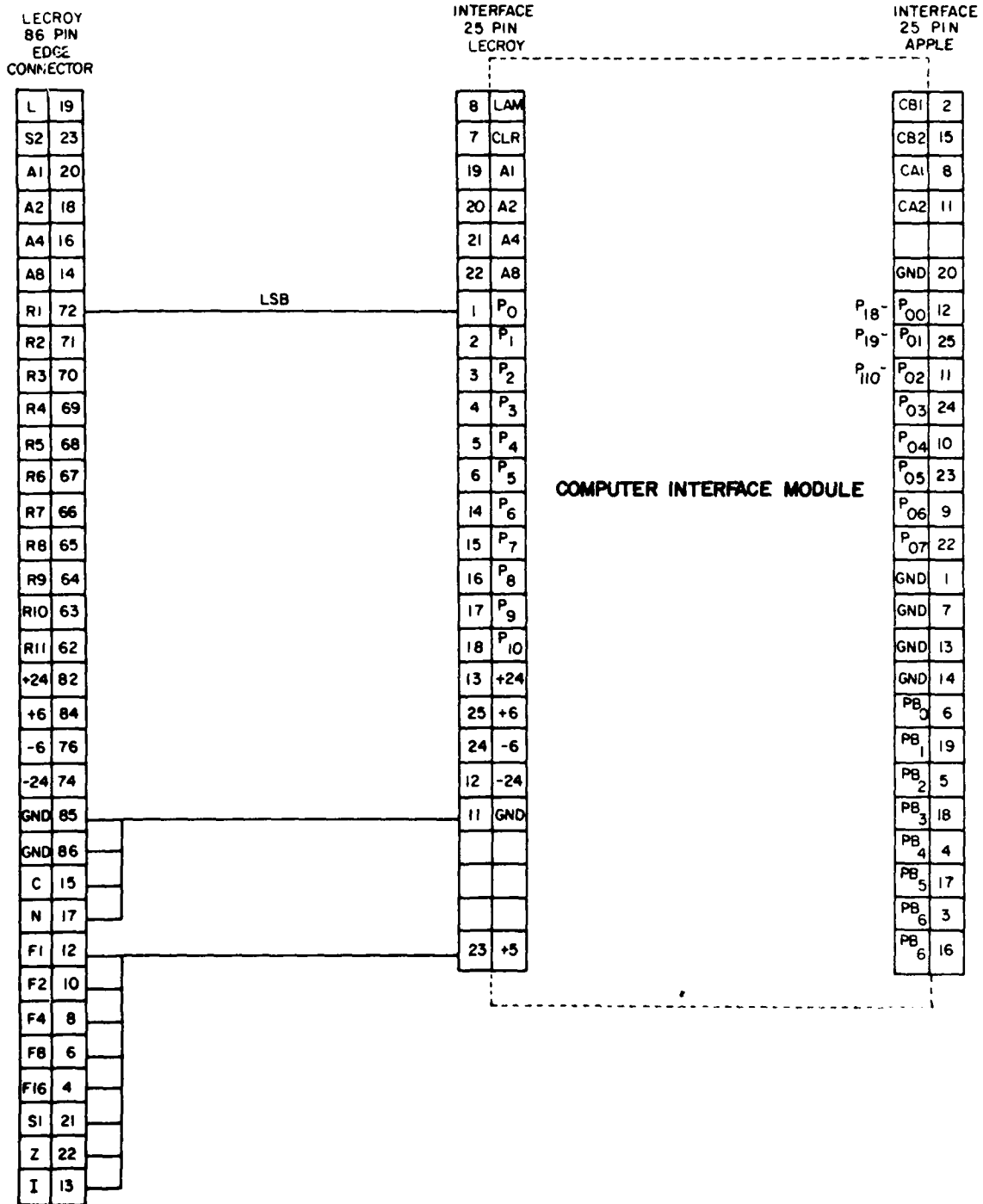

Figure A5. Computer-Interface Interconnections.