

AD-A 114 544

TECHNICAL
LIBRARY

AD

TECHNICAL REPORT ARBRL-TR-02399

THE SAFE TRANSPORT OF MUNITIONS (STROM)
PROGRAM, TASK 10 - THE USE OF BUFFERS,
OTHER THAN SPACER CARS, IN
PREVENTING PROPAGATION OF
EXPLOSION BETWEEN
RAILCARS

Philip M. Howe

DTIC QUALITY INSPECTED

April 1982



US ARMY ARMAMENT RESEARCH AND DEVELOPMENT COMMAND
BALLISTIC RESEARCH LABORATORY
ABERDEEN PROVING GROUND, MARYLAND

Approved for public release; distribution unlimited.

Destroy this report when it is no longer needed.
Do not return it to the originator.

Secondary distribution of this report by originating
or sponsoring activity is prohibited.

Additional copies of this report may be obtained
from the National Technical Information Service,
U.S. Department of Commerce, Springfield, Virginia
22161.

The findings in this report are not to be construed as
an official Department of the Army position, unless
so designated by other authorized documents.

*The use of trade names or manufacturers' names in this report
does not constitute endorsement of any commercial product.*

UNCLASSIFIED

SECURITY CLASSIFICATION OF THIS PAGE (When Data Entered)

REPORT DOCUMENTATION PAGE		READ INSTRUCTIONS BEFORE COMPLETING FORM
1. REPORT NUMBER Technical Report ARBRL-TR- 02399	2. GOVT ACCESSION NO.	3. RECIPIENT'S CATALOG NUMBER
4. TITLE (and Subtitle) The Safe Transport of Munitions (STROM) Program, Task 10 - The Use of Buffers, Other than Spacer Cars, in Preventing Propagation of Explosion Between Railcars		5. TYPE OF REPORT & PERIOD COVERED Final
		6. PERFORMING ORG. REPORT NUMBER
7. AUTHOR(s) Philip M. Howe	8. CONTRACT OR GRANT NUMBER(s)	
9. PERFORMING ORGANIZATION NAME AND ADDRESS US Army Ballistic Research Laboratory (ATTN: DRDAR-BLT) Aberdeen Proving Ground, MD 21005	10. PROGRAM ELEMENT, PROJECT, TASK AREA & WORK UNIT NUMBERS 1L162618AH80	
11. CONTROLLING OFFICE NAME AND ADDRESS US Army Armament Research and Development Command US Army Ballistic Research Laboratory (ATTN: DRDAR-BL) Aberdeen Proving Ground, MD 21005	12. REPORT DATE April 1982	
	13. NUMBER OF PAGES 102	
14. MONITORING AGENCY NAME & ADDRESS (if different from Controlling Office)	15. SECURITY CLASS. (of this report) UNCLASSIFIED	
	15a. DECLASSIFICATION/DOWNGRADING SCHEDULE	
16. DISTRIBUTION STATEMENT (of this Report) Approved for public release, distribution unlimited.		
17. DISTRIBUTION STATEMENT (of the abstract entered in Block 20, if different from Report)		
18. SUPPLEMENTARY NOTES		
19. KEY WORDS (Continue on reverse side if necessary and identify by block number) munitions mass detonation shock initiation shielding		
20. ABSTRACT (Continue on reverse side if necessary and identify by block number) (dlc) STROM Task 10 is a technical and operational feasibility study of the use of buffers, other than spacer cars, in preventing propagation of explosion from railcar to railcar: Given that a detonation occurs within the munitions contained in one car, is it feasible to prevent munitions contained in other cars from augmenting that explosion? (continued)		

20. ABSTRACT (continued)

Experiments and analysis were conducted for 155 mm SLP and the MK 80 series bombs. Results demonstrated that it is technically feasible to limit the size of an explosion to a single unit of munitions, where that unit can be a railcar load, a multiple pallet unit, or a single munition.

The techniques used involve various combinations of unit shielding, re-orientation, and spacing. Spacing is a critical factor and drives costs up both because of increased dunnage requirements and because of reduced carrying capacity.

It was demonstrated that modification of the nose configuration of the MK 80 series bomb, by redesign of the plastic nose plug, significantly reduces probability of propagation between units of MK 80 bombs, stacked in nose-nose, base-base configuration, provided adequate spacing is maintained between units. It was inferred from data resulting from the Roseville explosion that approximately 1 m is an adequate spacing between units of MK 81 bombs.

TABLE OF CONTENTS

	PAGE
LIST OF ILLUSTRATIONS	5
LIST OF TABLES	7
I. EXECUTIVE SUMMARY	9
II. INTRODUCTION	10
III. BACKGROUND	10
1. Propagation Mechanisms and Implications	10
2. Choice of Munitions for Intensive Study	12
3. Options Considered	12
IV. TEST RESULTS AND ANALYSIS	13
1. Technical Feasibility	13
a. Individual Munition Shielding	13
b. Sandbags Between Pallets	14
c. Reconfiguration	17
d. Pallet Shielding	21
e. Shields as Part of a Specially Designed Car	26
2. Operational Feasibility	28
a. Introductory Comments	28
b. Regulatory/Procedural Considerations	29
c. Operational Considerations.	30
d. Carrier Considerations.	54
e. Manpower Considerations	54
f. Cost Considerations	71
g. Procedures for Logistic Control	71

TABLE OF CONTENTS (CONTINUED)

	Page
3. Discussion	78
V. CONCLUSIONS.	81
REFERENCES	83
APPENDIX A - MULTIPALLET UNITS OF SLP.	85
APPENDIX B - TEST PLAN FOR MULTIPALLET UNITS FOR SLP	89
APPENDIX C - CONTROL OF EXPLOSIVE SIZE FOR MK 80 SERIES BOMB	93
APPENDIX D - TEST PLAN FOR CONTROL OF EXPLOSIVE SIZE OF MK 80 SERIES BOMB.	97
DISTRIBUTION LIST.	101

LIST OF ILLUSTRATIONS

Figure	Page
1. Configuration used to test effectiveness of sandbags in preventing interpallet propagation. Sandbags in contact with pallets.	15
2. Configuration used to test effectiveness of sandbags in preventing propagation between pallets. Sandbags separated from pallets by 10 cm airspace.	16
3. Schematic drawing of M107 155 mm projectile	18
4. Typical test configuration to determine nose-nose, base-base interactions.	19
5. Eight pallet nesting configuration suitable for rail transport	20
6. Configuration of bombs as believed to have participated in Roseville, California, explosion in 1973.	22
7. Radiograph showing mass focussing in symmetry plane between two simultaneously detonated pipe bombs	24
8. The shielded 16 round unit, as used in STROM tests.	31
9. Sixteen round shielded units configured in standard 20 foot milvan container.	32
10. Schematic configuration of 32-round units on 50 foot 0 inch boxcar.	45
11. Boxcar loading diagram for 64-round unshielded 155 mm SLP pallets	49
12. Uniform annual costs versus inhabited building distance and fragmentation distances for various options	80

LIST OF TABLES

Number		Page
I.	Container Leasing Charge (Conventional Pallet)	34
II.	Container Leasing Charge (Shielded Pallet)	35
III.	Rail Transportation Costs - 8-Round Conventional Pallet	36
IV.	Rail Transportation Costs - 16-Round Shielded Pallet	37
V.	Conventional Pallet Transportation Cost (Container). . .	39
VI.	16-Round Shielded Pallet Transportation Cost (Container).	40
VII.	Rail Breakbulk Demurrage Charges - 8-Round Conventional Pallet.	41
VIII.	Demurrage Cost (TTX Shipping) (Conventional Pallet). . .	42
IX.	Rail Breakbulk Demurrage Charges - 16-Round Shielded Pallet	43
X.	Demurrage Cost (TTX Shipping) (Shielded Pallet).	44
XI.	Rail Transportation Costs - 32-Round Shielded Pallet . .	46
XII.	Rail Breakbulk Demurrage Charges - 32-Round Shielded Pallet	47
XIII.	Rail Transportation Costs - 64-Round Unshielded Pallet .	50
XIV.	Rail Breakbulk Demurrage Charges - 64-Round Unshielded Pallet	51
XV.	Water Tank Procurement	52
XVI.	Increased Transportation Cost (End-of-Car Water Tanks) .	53
XVII.	Water Tank Retrosipping Cost.	55
XVIII.	End-of-Car Water Tank Salvage Values	56
XIX.	Palletization Costs/Unit - 8-round Conventional Pallet .	57

LIST OF TABLES (CONTINUED)

Number		Page
XX.	Palletization Costs/Unit - 32-Round Shielded Pallet. . .	58
XXI.	Palletization Costs/Unit - 64-Round Unshielded Pallet. .	59
XXII.	Palletization Requirements	61
XXIII.	Palletization Costs (Unit Costs X Requirements).	62
XXIV.	Loading Costs (Breakbulk) - 8-Round Conventional Pallet	63
XXV.	Loading Costs (Breakbulk) - 16-Round Shielded Pallet . .	64
XXVI.	Loading Costs (Breakbulk) - 32-Round Shielded Pallet . .	65
XXVII.	Loading Costs (Breakbulk) - 64-Round Unshielded Pallet	66
XXVIII.	Container Loading Cost - Conventional 8-Round Pallet . .	67
XXIX.	Container Loading Costs - 16-Round Shielded Pallet . . .	68
XXX.	Water Tank Handling Costs.	69
XXXI.	Water Tank Filling and Emptying Costs.	70
XXXII.	End-of-Car Water Tank Logistic Control Costs	72
XXXIII.	End-of-Car Water Tank Maintenance Costs.	73
XXXIV.	155 mm SLP Shielded Pallet - Cost Summary.	74
XXXV.	Economic Analysis Summary.	75
XXXVI.	Inhabited Building Distances and Fragment Distances for Various Sizes of Explosions of 155 mm Projectiles. . .	79

I. EXECUTIVE SUMMARY

1. STROM Task 10 is a technical and operational feasibility study of the use of buffers, other than spacer cars, in preventing propagation of explosion from railcar to railcar: Given that a detonation occurs within the munitions contained in one car, is it feasible to prevent munitions contained in other cars from augmenting that explosion?

2. Experiments and analysis were conducted for 155 mm SLP and the MK 80 series bombs. Results demonstrated that it is technically feasible to limit the size of an explosion to a single unit of munitions, where that unit can be a railcar load, a multiple pallet unit, or a single munition.

3. The techniques used involve various combinations of unit shielding, reorientation, and spacing. Spacing is a critical factor, and drives costs up both because of increased dunnage requirements and because of reduced carrying capacity.

4. It is recommended that breakbulk rail shipments of 155 mm SLP be configured in thirteen each eight pallet units per 50 foot railcar. Units should be oriented nose-nose, base-base, with munition principal axes parallel to the main axis of the railcar.

5. It was demonstrated that modification of the nose configuration of the MK 80 series bomb, by redesign of the plastic nose plug, significantly reduces probability of propagation between units of MK 80 bombs, stacked in nose-nose, base-base configuration, provided adequate spacing is maintained between units. It was inferred from data resulting from the Roseville explosion that approximately 1 m is an adequate spacing between units of MK 81 bombs.

6. It is recommended that tests be conducted with units of bombs, containing nose plugs, to verify the safe distance between units.

7. In the event that the distances between such units are not prohibitively large, it is recommended that MK 80 series bombs be shipped, with nose plugs, oriented nose-nose, with appropriate spacing between units.

II. INTRODUCTION

1. Objective. The objective of Task 10 was to determine the technical and operational feasibility of reducing the risk of propagation of an explosion from railcar to railcar. Spacer cars were specifically excluded from this study, being addressed elsewhere within the STROM Program.

2. Approach. To achieve this objective, an initial, careful assessment of the available, proven techniques was made. When it was found that the available technology was inadequate to serve the purposes of this task, a combined experimental/analytical approach was formulated. Heavy reliance was placed upon ongoing 6.1 and 6.2 research and exploratory development programs to provide the necessary understanding and mechanistic information. Indeed, throughout the entire course of this task, input from 6.1 and 6.2 programs was used. Candidate techniques were chosen based upon the assumption that transport requirements could place a premium upon space, weight, and material costs. All options described in the initial charter of the program were addressed, at least to determine technical feasibility. Those options which were demonstrated to be technically feasible and did not have obvious criteria for rejection were subjected to an analysis of operational feasibility.

The management and coordination of this task, as well as most of the analysis of technical feasibility and experimental work, was conducted by the US Army Ballistic Research Laboratory, USAARRADCOM. Some testing and analysis was performed by the US Naval Weapons Center. The entire operational feasibility analysis and much of the literature search was conducted by the US Army Defense Ammunition Center.

III. BACKGROUND

1. Propagation Mechanisms and Implications. The propagation mechanisms strongly influence the possible approaches which can be used to reduce the size of an explosion, and are, thus summarized briefly below.

The development of an explosion among mass-detonable stores can be considered to occur in two steps; an initial step which leads to the detonation of one or more individual munitions, and a propagation phase, where nearby munitions are subjected to the severe blast and fragment loading from munitions which have detonated and, through a variety of processes, detonate themselves, or react sufficiently violently to insure continuation of the events throughout the array.

The initial event can occur by either of two processes, impact or fire. In the background study for this task and for Task 2, it was determined that the principal cause of the initial event is fire, for transport-related explosions. Since the thermal environment which a munitions array

sees is rarely isotropic, typically a single munition will cook off before others and the source of the explosion can be considered to be a single munition. No instance of an accidental (i.e., excluding hostile action) explosion of munitions in transport has been identified as resulting directly from impact.

Mass detonation occurs as the result of propagation of explosion through the array. Impact provides the primary process by which propagation through the array occurs. Several mechanisms are involved. For munitions containing moderately sensitive explosives (all explosives currently used as standard fills in US Army munitions fall into this category) and configured in arrays with high packing densities (as in standard artillery shell pallets, for example) shock initiation can lead to prompt - within 50-100 microseconds - detonation of neighboring munitions, in the event that one munition detonates. Peak pressure, shock rise time, and duration of the shock determine whether or not the shock-loaded munition will detonate. Since the duration of the pulse depends most strongly upon the size of the donor munition, most approaches to overcome the shock initiation threat rely upon reducing the peak pressure and increasing the shock rise time. The shock rise time can be modulated to some degree by appropriate use of shielding materials/configuration. The peak pressure can be reduced by introduction of shielding or, to some extent, by separating the munitions to capitalize upon divergence effects. The limit of the latter approach is determined by the size and velocity characteristics of the primary fragments from the donor munition.

If classical shock initiation has been eliminated as a mechanism, propagation of detonation from munition to munition can occur as a result of rapid casing failure caused by the severe loading associated with multiple fragment and blast loading (for small distances between charges) or single fragment impact (at larger separations). Thus, a requirement for effective control of the size of an explosion in a munitions array is that the rate of deformation and structural failure of the munitions be kept below a threshold value, which threshold value must be determined experimentally.

For munitions containing brittle and reactive explosives such as composition-B or TNT, shattering of the munitions must be prevented, as both calculations¹ and experiments indicate that reaction of the explosive within the fireball contributes to the blast.

¹Oppenheim, A. K., et al, "Blast Waves Generated by Exploding Clouds," *Shock Tube & Shock Wave Research*, 1978, published by University of Washington, pp 465-473, *Proceedings of Symposium*.

The above considerations led to the conclusion that there are three factors which can be exploited to control the size of an explosion of mass-detonable munitions; shielding, spacing, and reconfiguration. The first two factors affect the severity of the stimulus delivered to the neighboring munitions by the fragments and explosive products from the detonating source munition(s). The third factor utilizes the nonisotropy of the munitions to insure that the target munitions are placed in position to receive the weakest possible part of the donor munition threat, and to insure that the target munitions are oriented so that they can offer greatest resistance to the incoming threat. These three factors were evaluated in different combinations, to arrive at various technical options.

2. Choice of Munitions for Intensive Study. At the outset of the study, it was apparent that the particular approaches which might be effective would strongly depend upon the munitions involved, and a global solution applicable to all munitions was unlikely to be obtained. The M107 155 mm separate loading projectile was chosen to receive primary attention. This decision was based upon the facts that (a) past history and projected usage rates indicated that the 155 mm projectile is a high volume item and (b) the 155 mm projectile has a high propensity for mass detonation^{2,3}. This projectile comes filled with either TNT or composition-B explosive. Since the composition-B filled projectiles are more powerful - thus, a more serious threat - and more sensitive, all tests were conducted with these shells. Any solution which would work for the composition-B filled shell would also work for TNT filled rounds.

Consideration was also given to the MK 80 series general purpose bombs, because of the large quantities shipped and because of the severity of the mass detonation problem.

3. Options Considered. The following approaches were considered:
- a. Shields between individual munitions, spacing as needed.
 - b. Sand bags between pallets, spacing as needed.
 - c. Reconfiguration of pallets within transport vehicle, spacing as needed.
 - d. Shielding between multiple pallet units, spacing as needed.

²Dobbie, J. and Allan, D., "An Analytical Model to Predict Explosion Propagation," Minutes, DOD Explosive Safety Board, Sixteenth Explosive Safety Seminar, Hollywood by the Sea, FL (1974).

³Parkinson, A. and Smith, K. T., "T209 Milvan Container Storage Tests Final Report," Toole Army Depot (1975).

e. Shields or barriers as part of a specially designed car.

(1) Fire retardant-treated lumber.

(2) Steel ammunition pallets.

(3) Outgassing agents.

f. Plastic nose plugs for MK 80 series bombs.

Items b and e were addressed because they were specifically requested in the original STROM tasking documents. Technical details and test data for the various options will be contained in a data report to be published as a sequel.

IV. TEST RESULTS AND ANALYSIS

1. Technical Feasibility.

a. Individual Munition Shielding. The first approach tried involved the use of plastic shielding between individual munitions. Plastic was chosen because it was lightweight and does not readily transmit the shock wave to the acceptor. Placement of plastic between the detonating munition (the donor) and its neighbors can greatly increase the rise time of the shock wave transmitted to the explosive in the neighboring munitions. In addition, significant reductions in peak pressure transmitted to the explosive can be obtained. Thus, by appropriate use of spacing, and with appropriate thicknesses of plastic between munitions, propagation of detonation between 155 mm projectiles can be prevented. Test data are provided in the appendix. Here, it is sufficient to note that, when the spacing between 155 mm M107 composition-B filled projectiles is one caliber, a 1.27 cm (0.5") thick layer of plastic placed midway between rounds is adequate to prevent detonation of the neighboring rounds, given the detonation of a donor. The width of the plastic must, of course, be approximately one-half the munition caliber in order to prevent direct impact of donor fragments upon the acceptor projectiles.

Although the plastic is effective in preventing detonation of neighboring munitions, the nearest neighbor munitions are loaded sufficiently severely to cause their breakup into several small pieces, with exposure of the explosive to the fireball. This is not a severe problem with a 155 mm donor projectile, as the fireball is sufficiently short lived that pieces of unreacted explosive are sometimes recovered. However, this makes very difficult scale-up of the technique to large munitions - 500 lb bombs, 1000 lb bombs, etc - as, for these larger items, the explosive would react within the fireball and quite clearly contribute to the blast. It also will be a problem when more than one 155 mm round serves as the donor, as fireball duration increases with increased charge size.

The principal advantage of using shielding between individual munitions is that the size of the most probable explosion is small; the blast and fragment radii reduce to those for a single munition, viz, for the M107 155 mm projectile, and Inhabited Building Distance (IBD) of 30 m (98 ft) and a Fragment Distance of 122 m (400 ft)⁴. (The IBD is defined as the minimum permissible distance, between an inhabited building and an explosive location, that provides a high degree of protection to the building occupants from blast or shock effects. The Fragment Distance is defined as the range to which a hazardous fragment density may extend from the explosion of a particular type of ammunition. A hazardous fragment density is defined as a fragment energy density of one fragment with 78 joules/56 m² (reference 4)).

The disadvantages of this approach are twofold: The configuration is space inefficient, as approximately one caliber of spacing must be maintained between each munition. Secondly, although any plastic with nominal density 0.8 - 1.4 g/cc will work, plastics are petroleum based materials, are expensive now, and can be expected to increase in expense in coming years. For these reasons, further work with this approach was curtailed.

b. Sandbags Between Pallets, with Appropriate Spacing. The use of sandbags as shielding was specifically mentioned in the STROM charter document and hence, was considered here. Tests were conducted to determine whether sand barriers between 8-round pallets of 155 mm projectiles would be effective in limiting the size of an explosion to a single pallet. Tests demonstrated that a 20 cm (8 inch) thick barrier of sand placed between the pallets was effective in preventing propagation of detonation or reaction. Indeed, the munitions in the acceptor pallets were recovered essentially intact, indicating that the sand barriers could probably be reduced in thickness slightly.

To be effective as barriers, the sandbags cannot be placed in contact with the pallets. A 10 cm (4 inch) air gap between sandbags and pallets was found to be adequate for venting and decoupling of the loading. The test configurations are shown in Figures 1 and 2.

The primary advantage of this technique is that it provides a cheap, effective shielding approach. The size of an explosion can be limited to eight munitions (one pallet), with a blast inhabited building distance of approximately 120 feet and a fragment distance of 1250 feet.

The approach is not particularly weight efficient. For pallets stacked only one layer high, the weight of sand required per pallet is 334 kg (736 lb) effectively doubling the weight of the pallet based upon

⁴AMC Regulation 385-100, Change 3, Chapter 17 (1977).

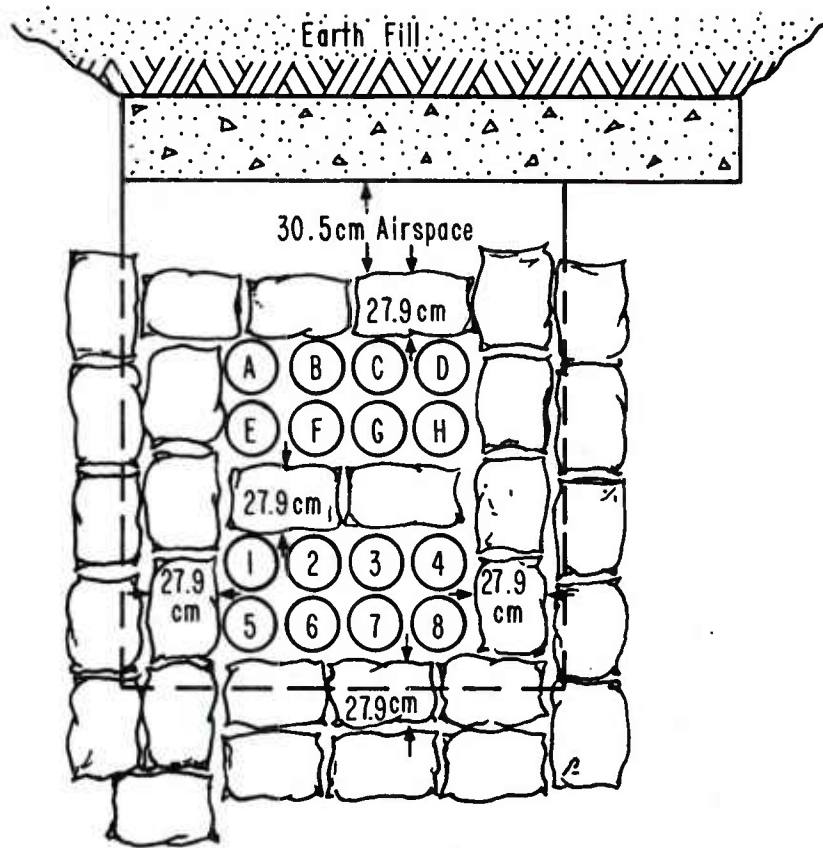

Figure 1 - Configuration used to test effectiveness of sandbags in preventing interpallet propagation. Sandbags in contact with pallets.

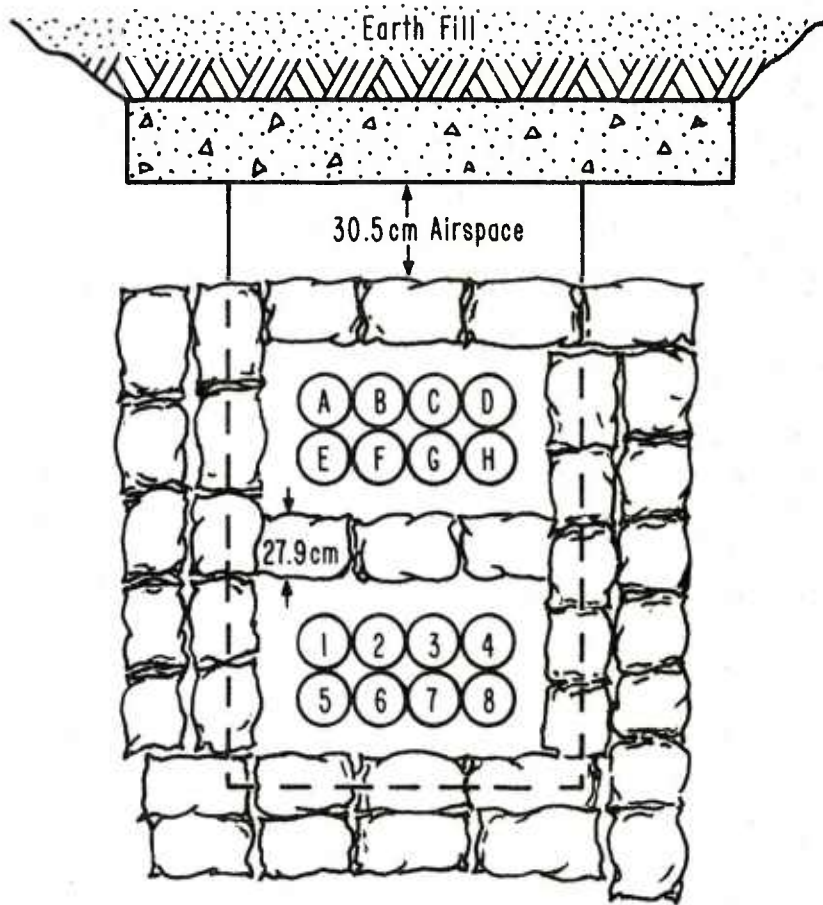

Figure 2 - Configuration used to test effectiveness of sandbags in preventing propagation between pallets. Sandbags separated from pallets by 10 cm airspace.

a nominal density for sand of 1.5 g/cc. Additional weight burdens would be incurred by the necessity for appropriate blocking and bracing. This approach is not especially space efficient, either. The required area per pallet is 0.7 m^2 (7.3 ft^2) with sandbags, compared with 0.25 m^2 (2.7 ft^2) for a standard pallet. No further attention was given to this approach.

c. Reconfiguration. A schematic drawing of an M107 155 mm shell is shown in Figure 3. In common with most gun launched ammunition, this design has the thinnest casing on the sidewall, with the nose and base providing much more material for protection against incoming fragments. While the sidewall is most vulnerable to fragment attack, it also is the source of the largest number of high velocity, lethal fragments. Thus, when such a munition detonates, the fragments from the sidewall present the greatest threat. Orientation of the pallets such that the munitions are oriented nose to nose and base to base should greatly reduce the tendency for propagation from munition to munition, since the nose-nose and base-base configurations provide at once a less lethal threat and a less vulnerable target.

Tests were conducted with single and multiple pallet units to ascertain what gains were possible. A typical test configuration is shown in Figure 4. Examination of the data indicates that this approach is very effective in eliminating fragment impact as a propagation mechanism. However, unless adequate spacing is placed between donor and acceptor units, rapid crushing with consequent detonation still occurs.

The combination of nose-nose, base-base orientation and proper spacing between units is very effective in limiting propagation of detonation. For transport on rail, where side exposure of munition laden railcars to other munitions stores is an occurrence of extremely low probability, this approach appears in itself adequate to prevent propagation within a railcar or from car to car. For 155 mm shell, a recommended configuration is shown in Figure 5. This configuration is composed of units of eight pallets each. When thus configured, propagation between units is greatly reduced (our tests would indicate that propagation is eliminated, but insufficient tests were conducted to provide reliability and confidence levels). Thus, the explosion is essentially limited to the donor unit of eight pallets. The inhabited building distance is, for this instance, reduced to 45 m (150 feet). The fragment distance is 390 m (1250 feet), however.

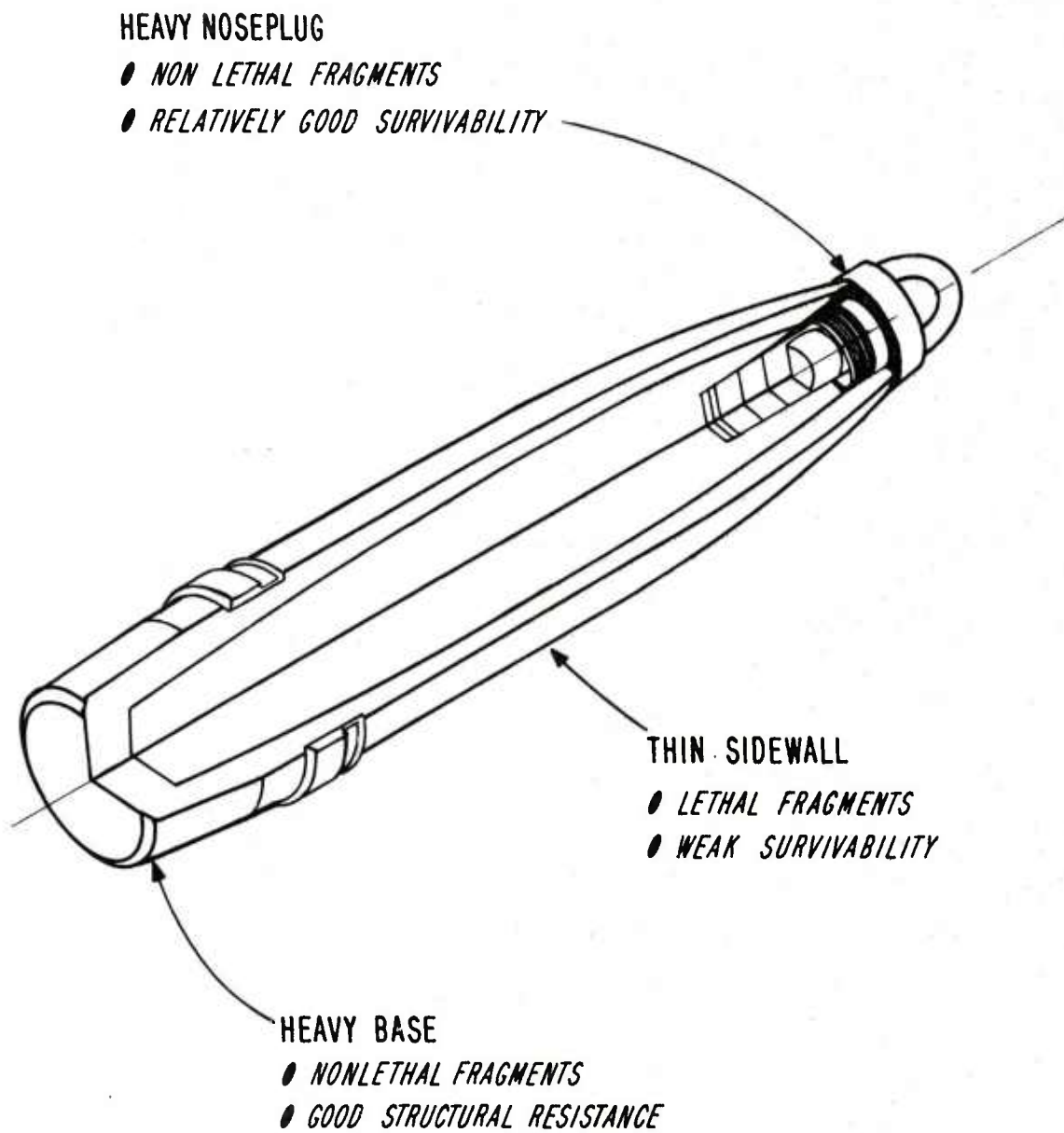

Figure 3 - Schematic drawing of M107 155 mm projectile.

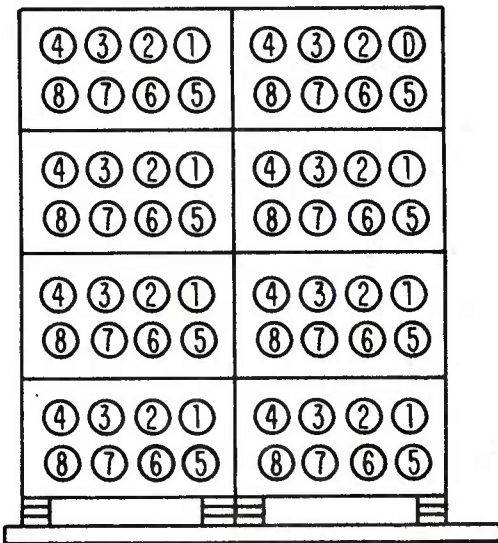
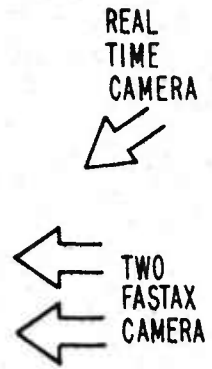
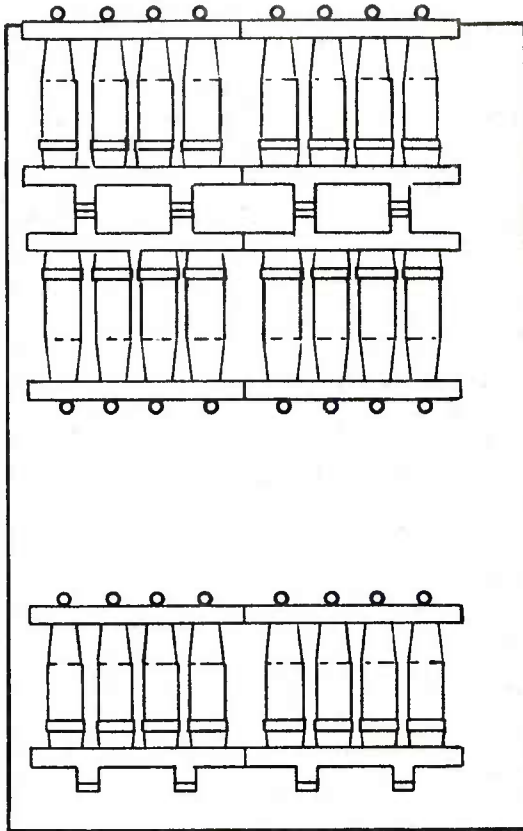

Figure 5 - Eight pallet nesting configuration suitable for rail transport.

This approach can, in principle, be applied to stores of any geometrically similar munitions. With the MK 80 series bombs, however, the warhead design is slightly different, and tests carried out at Naval Weapons Center, China Lake, demonstrate that jetting can occur from the collapse of the fuze cavity area when current-design bombs are detonated. This jetting was found to be sufficiently severe to cause initiation of neighboring bombs in the path of the jets. The tests were conducted with separation distances between nose of donor bomb and side of acceptor bomb varying from a minimum of 10 cm (4 inches) to a maximum of 61 cm (24 inches). The lethality of the jetting at greater separations would diminish very slowly due to air drag, and very slowly due to reduced probability of hit. For multiple pallet donor and acceptor units in nose-nose orientation aboard a railcar, the probability of hit would be expected to diminish slowly, also. Thus, to take advantage of nose-nose orientation, redesign of the nose plugs for the bombs is required.

Tests were conducted at Naval Weapons Center, China Lake, where the standard nose plugs in the MK 81 series bombs were replaced by specially made plastic nose plugs which completely filled the fuze well cavity, thereby eliminating jet formation, and preventing propagation from donor to acceptor by this mechanism.

It is expected that, even with specially designed nose plugs, a minimum spacing between bomb units would be required to prevent propagation via a crushing mechanism. As in the case of the 155 shell, this distance would be expected to be a function of the donor size. No tests were conducted to ascertain the safe nose-nose distance for multibomb units. However in the Roseville accident (see the Task 2 STROM report), detonation of entire railcars did not occur. Rather, the photographic evidence showed 1/2 car load lots detonating. The Roseville accident involved MK 82 bombs, probably configured as in Figure 6. Thus, separation distances of approximately 1 m between pallet appear to be effective, based upon the results of this single event. An unanswered question is why mass focussing from interacting rounds failed to cause detonation of the acceptors located across the gaps (see paragraph d, below, for description of mass focussing problem).

d. Pallet Shielding. While reorienting, with appropriate spacing, pallets or multipallet units, such that the units are oriented nose-nose and base-base significantly reduces the chance of propagation of detonation in one direction, clearly it does nothing to reduce propagation in the other two normal directions. Shielding techniques were developed to address this issue.

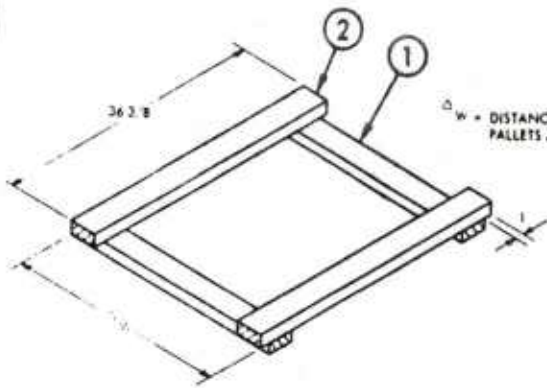

DETAIL A
SWAY BRACE FRAME
14 REQUIRED

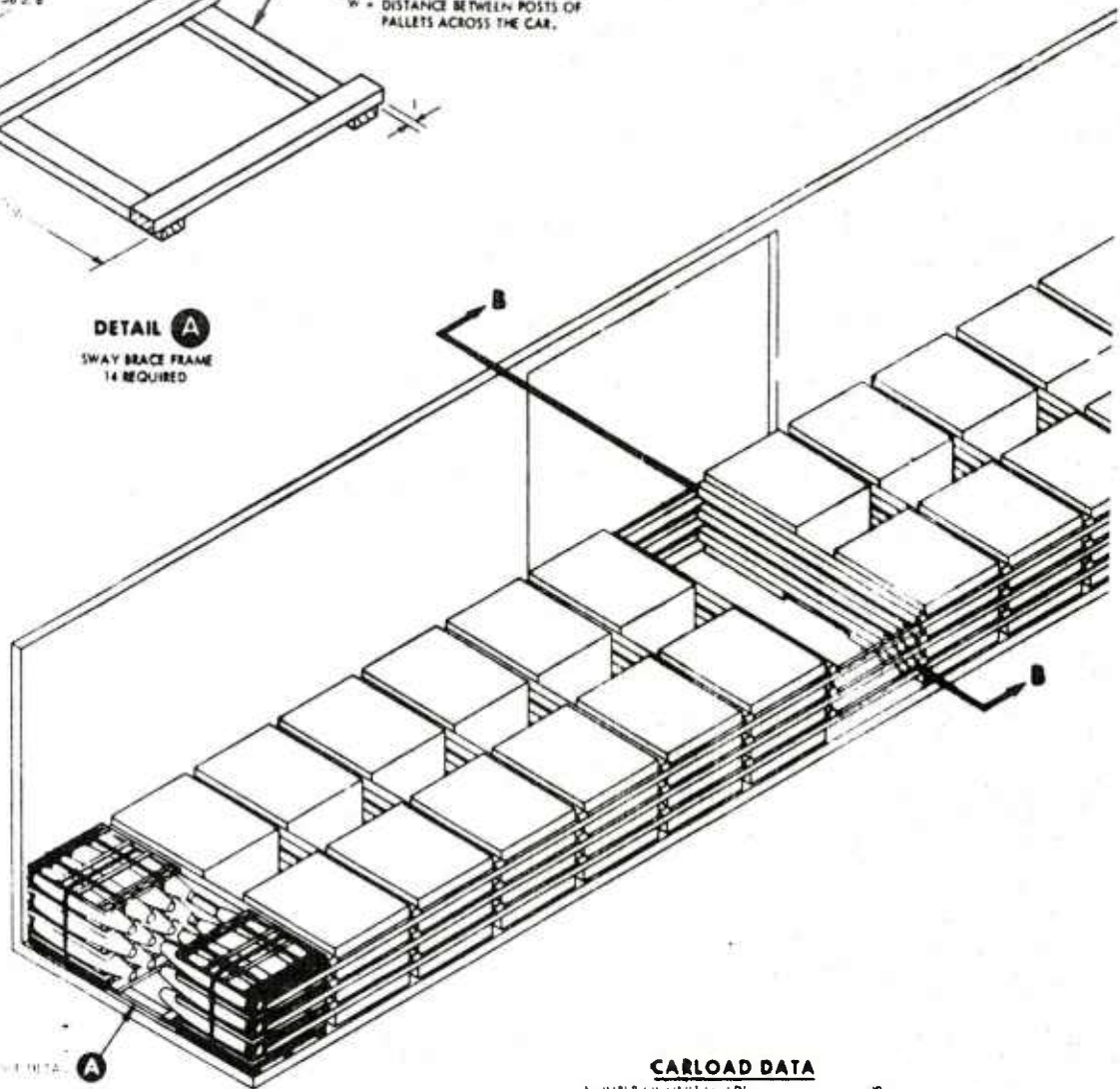

CARLOAD DATA

NUMBER OF UNITS (NO.)	28
NUMBER OF CROSSMEMBERS REQUIRED	42
LOAD WEIGHT (APPROXIMATE)	83,384 LBS
DUNNAGE WEIGHT (APPROXIMATE)	271 LBS
CARLOAD WEIGHT (APPROXIMATE)	82,655 LBS

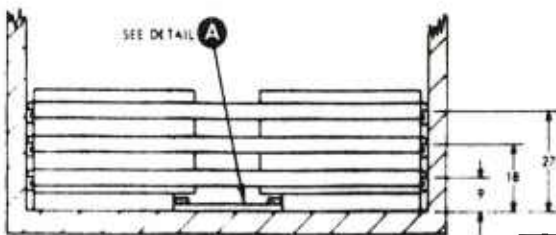

SECTION B-B
SHOWING LOCATION OF WALL MEMBERS
USED FOR CROSS MEMBERS

* NAIL LATERAL MEMBERS OF SWAY BRACE TO CAR FLOOR WITH TWO 16d NAILS EACH END.

PIECE NO.	DESCRIPTION	SIZE	NO. PCS REQD	NAIL TO	NAILS	
					NUMBER	SIZE
2	SWAY BRACE LONGITUDINAL	2 x 4 x 36 3/8	28	1	PER JOINT	10d
1	SWAY BRACE LATERAL	2 x 4 x CMT TO FIT	42	CAR FLOOR	SEE NOTE *	

LIST OF MATERIALS AND NAILING DATA

Figure 6 - Configuration of bombs as believed to have participated in Roseville, California, explosion in 1973.

When more than one munition in a closely packed array is allowed to participate in the explosion of the donor charge, all the mechanisms of communication associated with single munitions are present, but an additional, severe problem arises: the simultaneous, or near-simultaneous, detonation of closely packed munitions creates a high velocity focussed fragment beam in the symmetry plane between the munitions. The fragment velocities of this beam are typically of the order of twice those of fragments from a single munition. Since the beam is collimated, these fragment beams present a very serious threat to other munitions, even over large distances. The nature of the mass focussing can be seen in the radiographs in Figure 7. The penetration capability of this focussed beam is about a factor of three greater than that of fragments from the individual munitions. The fragment beam resulting from simultaneous detonation of two 155 mm shells (TNT loaded) was found to perforate a 10 cm mild steel plate located 30 cm away from the nearest edge of the two munitions.

To be effective for multi-munition donors, a shield must eliminate lethal primary fragments, eliminate the mass focussing as a threat, and not serve as a lethal fragment itself. The latter consideration drives attention towards frangible, low density materials and away from steel (steel plates can store enough energy to be lethal sources of initiation, especially by crushing).

Gypsum board was chosen as a shield material because it met the above requirements, as well as being relatively inexpensive, and readily available commercially. It was also chosen on the belief that if sufficient shock energy was absorbed, the water of hydration would be released as steam and could be used as a working fluid. However, recent experiments do not support this hypothesis, and this shielding approach relies solely upon the areal density of material within the fragment paths. Experiments with steel, aluminum, plaster, and water shields with thicknesses adjusted to insure the same areal density, showed essentially no difference in shield effectiveness in eliminating hazardous fragments⁵. Of course, the stronger and denser materials, such as steel, should be avoided because of the ease with which they deliver energy to the acceptor munitions, leading to higher delivered pressures and greater tendencies for detonation.

The effectiveness of this shielding approach relies strongly upon proximity of the shield to the donor munitions. Separation of the shield from the donor projectiles by as much as a projectile caliber seriously

⁵Gibbons, Gould, *Ballistic Research Laboratory, private communication.*

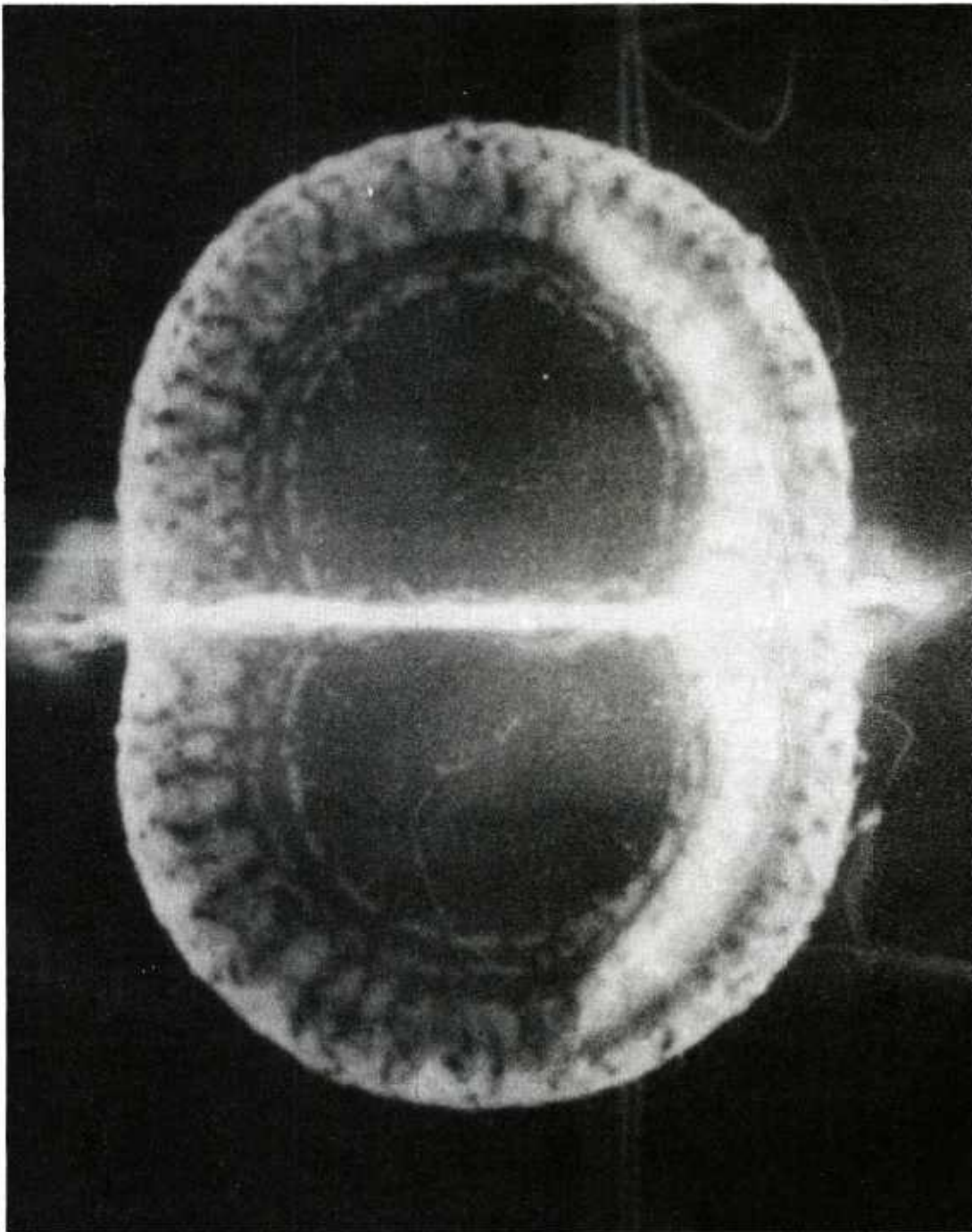

Figure 7 - Radiograph showing mass focussing in symmetry plane between two simultaneously detonated pipe bombs.

degrades shield performance. This degradation results, at least partially, from the lack of structural integrity of shields - which lack is a deliberate and necessary design feature, as stated above. When the shields are placed away from donor munitions, the loading environment essentially consists of many individual fragment impacts. Since the shields have little perforation resistance, it cannot efficiently decrease the velocity of the fragments.

This shielding approach is very effective against primary fragments and against the fragment beams. Indeed, using the gypsum-based wall-board, a 5 cm (2 inch) thick shield is adequate to prevent propagation, by either of these mechanisms, between units of TNT filled 155 mm shell. A 7.6 cm (3 inch) shield is required for the more powerful composition-B filled shell.

The shields are not at all effective in preventing propagation from unit to unit by means of crushing, and adequate spacing must be maintained between units. As can immediately be ascertained by application of replica scaling analysis, the spacing required is a function of the size of the donor unit, with larger units requiring significantly larger separations.

It is extremely important that adequate spacing be maintained to prevent detonation of the acceptor as a result of crushing. The crushing mechanism operates more slowly than does the projectile impact initiation, and times are long enough for the shielding on the acceptor pallets to deform and move away from the munitions. To be effective, the shields must be in contact with the munitions. Thus, when crushing causes detonation of an acceptor unit, the shields are ineffectual, and all undetonated nearest neighbors of the detonating acceptor unit are subjected to lethal fragment impacts.

The shield concept discussed here has been applied successfully to single and double pallet units. It is most efficiently used in conjunction with reconfiguration as discussed in para 3c, above. Its primary advantage is that it can reduce the inhabited building distance to that for the explosive contained within a shielded unit - a single pallet, for example. No evidence exists to indicate that the fragment hazards are appreciably affected by the shielding, although there presumably is, at least, a slight improvement. This approach has several disadvantages; the additional cost of the shielding, the requirement for spacing between units, the need for additional blocking and bracing. (These latter factors are addressed in the operational impact section.)

e. Shields as Part of a Specially Designed Car. In Task 2 of the STROM Program, it was pointed out that the development of a mass detonation could be considered to consist of two steps; an initial event, which involved the detonation of one or more munitions, and a second phase, during which propagation through the munition array occurs. Fire was established to be the principal cause of explosions of munitions during rail transport. A significant level of effort was conducted under STROM Tasks 7, 8, and 9 to address ways in which serious fires could be eliminated or their frequency reduced and a special design car was developed under Task 8. As part of a special design car, it may be possible to include a shield which will limit the extent of an explosion to one car given that initiation occurs. To be effective, such buffering must defeat all prompt inter-car propagation mechanisms. Thus, the buffer must be designed to prevent transmission of lethal fragments from the donor car to munitions within the neighboring cars, must prevent delivery of strong shock waves which could cause classical shock initiation, and must prevent rapid crushing of the munitions within neighboring railcars. These requirements constrain the materials and engineering approaches which are technically feasible.

It is relatively easy to generate designs which will stop, or slow primary fragments from individual munitions to the point where the fragments are no longer lethal. Sophisticated and esoteric body armors can be used, although quite expensive, or even mild steel plates can be used, with required thicknesses seldom in excess of the thicknesses of the warhead casing providing the fragment threat. However, implied in this buffering approach is the fact that a large number (perhaps all) of the munitions within a railcar will participate in the initial explosion. When multiple munitions detonate simultaneously or near simultaneously, the fragmentation threat is markedly enhanced. Thus, tests conducted under Task 10 demonstrated that the fragmentation resulting from simultaneous detonation of two contiguous 155 mm shell (composition-B or TNT filled) creates a fragment field in the symmetry plane between the two munitions sufficient to perforate approximately 10 cm of mild steel, when the steel plate is approximately 25 cm from the skin of the munitions. Experiments with 50 mm diameter steel pipe bombs demonstrated that the perforation capability roughly scales linearly with the diameter of the donor projectiles, so even thicker steel barriers would be required for larger munitions. For example, the thickness of mild steel necessary to stop the synergistic fragmentation in the symmetry plane resulting from the detonation of two 500 lb MK 82 bombs is estimated to be approximately 20 cm. At a nominal density of 7.8 g/cc, this translates to a mild steel shield weight of approximately 5800 kg (12,760 lb). With a shield at each end of the car, this imposes a weight burden of 11,600 kg or 25,500 lb. This weight could be reduced considerably (perhaps as much as 30 percent) by permitting the fragments to have a significant residual velocity. While this weight of steel might be operationally acceptable, an additional technical problem exists. High density

monolithic shields are to be avoided because they are very effective transmitters of energy and momentum. Unless they are placed at significant distances from the detonating stores, the steel plates themselves become massive, highly lethal projectiles which can be expected to cause crushing and detonation of neighboring stores. An example of just this happenstance has been reported for concrete fragments⁶. Thus, to prevent this latter mechanism of initiation from occurring, buffers must be lightweight or frangible, so that the total impulse is spread out in time sufficiently to prevent the peak pressure delivered to the acceptor munitions from exceeding the yield strength of the munitions. Thus, attention was given to materials such as glass, water, and sand. Water was chosen in preference to glass or sand, because of its cost, availability and with the hope that it might provide some inhibition for propagation of fires, as well.

A test was conducted at NWC, China Lake, to demonstrate the feasibility of using 1 foot water tanks at the ends of a railcar to prevent the initiation of a second car. The test used a salvaged railcar, cut in two and placed end-to-end with floors 4 feet above the ground. Car ends were fitted with 1 by 8 by 10 foot water tanks. Six pallets of MK 82/H-6 bombs without fuzes or boosters were placed in each half-car, oriented nose to end-wall. Thirty-six bombs in the donor boxcar were end initiated as recommended by the Ballistic Research Laboratory (BRL). This means of initiation is contrary to that experienced in actual cook off tests that resulted in detonation(s), and provides a "worst case" situation.

The test involved 72 MK 82/H-6 standard Navy loads. At 195 pounds of H-6 per bomb, a total of 14,040 pounds of explosives were exposed in the test. It was anticipated that all of the 36 bombs in the donor car would detonate and that none of the acceptor car bombs would be initiated, giving an explosive load of 7,020 pounds of H-6 with a TNT equivalence of 130 or 9,130 pounds TNT.

The post-test results showed that the acceptor boxcar was initiated at least in part. The overhead post-test examination of the area showed two distinct craters for the donor and acceptor boxcar halves. The donor crater is about three times the size of the acceptor crater. Several bomb cases were found which originated from the acceptor boxcar, indicating that some bombs only exploded instead of detonating. Apparently, the water tanks almost stopped the communication between the boxcars. This was indicated by the fact that the acceptor crater was about one-third the size of the donor crater. Therefore, it appears technically feasible, at least for bombs, to prevent car to car propagation of detonation by use of water tanks.

⁶Rindner, R. and Forsten, I, "Safety Design Considerations in Munition Plants Layout," ACS Symposium Series, No. 96 (1979).

Limiting the detonation to a single carload of MK 82 bombs would establish a hazardous blast distance for inhabited structures of 1500 feet (based upon a 50 foot 6 inch carload of 45 unit loads with six bombs per unit^{7,8}). The safe distance for fragments in this instance is 1240 feet⁸. Thus, reduction of the size of the event to one carload reduces the blast radius for inhabited buildings almost to the fragment radius. Further reduction of the blast radius would not reduce the fragment radius but would, of course, reduce the total risk to buildings and inhabitants.

It is not valid to apply this approach directly to other munitions systems, without careful analysis and test data for verification. The fact that the acceptor carload reacted, in the test described above, indicates that crushing was sufficiently severe to cause bomb reaction. Other munitions - such as 155 mm shell and other composition-B or TNT filled munitions -- which are more sensitive to crushing environments would have a high probability of detonating. The detonation of one munition makes highly probable detonation of others within the array. The end of the car shield approach must therefore be considered as specific to MK 80 series bombs, and cannot, without further testing/analysis be applied to all mass detonable stores. For this type of shielding approach, however, additional spacing between donor and acceptor cars would markedly decrease the severity of the transmitted loading. In principle, combinations of spacing and end of car water tanks could be defined for all common types of mass detonable munitions.

2. Operational Feasibility.

a. Introductory Comments. A variety of techniques has been considered for effectiveness in limiting the size of an explosion. Each of these techniques was pursued until technical feasibility could be assessed. Several of the techniques are feasible alone, some work best when combined with others. The following combinations of approaches provide a sequence ordered according to increasing explosion size:

(1) Shielding, spacing, reconfiguration (for small units of projectiles, e.g., 2-, 4-, 8-pallet units).

(2) Spacing, reconfiguration (for large units of projectiles, e.g., 8-pallet units aboard railcars, where side to side propagation is not a potential problem).

(3) Spacing, reconfiguration, nose plugs (for the MK 80 series of bombs).

(4) Spacing, end shields (for carloads of projectiles and bombs).

⁷WR52/100, p 26, *Naval Ordnance Systems Command.*

⁸AMCR 385-100 (1977).

The outgassing approach, although potentially very useful, cannot be applied to munitions already in the inventory and, hence, is not discussed further. Likewise, the specially designed pallet was found, very early in this study, to have very high expected material costs, and was discarded from further consideration.

From the collection of approaches discussed in the previous section, a set of specific options was chosen for assessment of operational feasibility, and to permit cost-benefit trade-offs. The following alternatives were analyzed.

- 16-round shielded 155 mm SLP pallet.
- 32-round shielded 155 mm SLP pallet.
- 64-round unshielded 155 mm SLP pallet.
- End-of-car water tanks.

Each of these options will be compared with the status quo; i.e, the present method of shipping ammunition.

The operational feasibility of employing the various alternatives encompasses five areas of consideration:

- Regulatory considerations.
- Operational considerations.
- Carrier considerations.
- Manpower considerations.
- Cost-benefit considerations.

b. Regulatory/Procedural Considerations.

(1) 16 and 32-Round Shielded and 64-Round Unshielded Pallets.

Due to the spacing requirement of these ammunition shipping configurations, adoption of any of these options in boxcars or intermodal containers would require appropriate blocking and bracing diagrams. These drawings would have to be designed, rail impact tested, and subsequently included in the Association of American Railroads (AAR) Bureau of Explosives Pamphlet Nos. 6 and 6A.

(2) End-Of-Car Water Tank Blast Shields. A mandatory requirement for these shields in each end of a railcar transporting Class A munitions would require an addition to Title 49 of the Code of Federal

Regulation (49 CFR). The specific change to 49 CFR would be in the form of the addition of subparagraph (p) to paragraph 174.101. Subparagraph (p) would read:

"The shipper of Class A explosives must procure, place, and fill water tank blast shields in each end of the rail car. These tanks must be 9 feet wide by 8 feet high by 1 foot deep and constructed of welded 1/4-inch steel plate."

A similar modification to the Military Traffic Management Regulation (NTMR) would be required. The logistics management of these water tanks should be accomplished by the DARCOM Joint Container Control Office (JCCO) in accordance with AR 55-1.

c. Operational Considerations.

(1) 16 and 32-Round Shielded and 64-Round Unshielded Pallets.

These units employ interpallet spacing and suppressive shielding to prevent interpallet propagation of 155 mm separate loading projectiles (SLP). The shielding medium is a 3-inch thick sandwich comprised of a 1/4-inch thickness of pressed hardboard (Masonite), 4 thicknesses of 5/8-inch gypsum (wallboard), and a second layer of 1/4-inch pressed hardboard. (See Figure 8.)

(a) The 16-round shielded pallet consists of two conventional 8-round 155 mm SLP pallets laid horizontally and then stacked vertically. The shielding material is then applied to the bottom, top, and two sides of this 16-round bundle. The projectile nose and base ends of the pallet are not shielded. The pallet is completed by the application of skids to allow forklift truck access. The 16-round pallet is the only shielded option considered for transport in the 20-foot intermodal container and therefore aboard a container ship. Eighteen of these units, spaced for minimum probability of interpallet propagation, can be transported per 20-foot container. (See Figure 9.) This container capacity is somewhat less than the conventional outloading method of 42 eight-round pallets. In a 50 foot 6 inch rail box car, 54 shielded 16-round pallets can be accommodated. Note that laterally adjacent pallets are staggered by half of their longitudinal dimension to enhance survivability. This staggering and all spacing are maintained by the installation of wooden blocking and bracing or dunnage. Since the shielded pallets and the transportation spacing patterns associated with them allow fewer rounds to be transported per transportation vehicle, certain economic penalties are encountered.

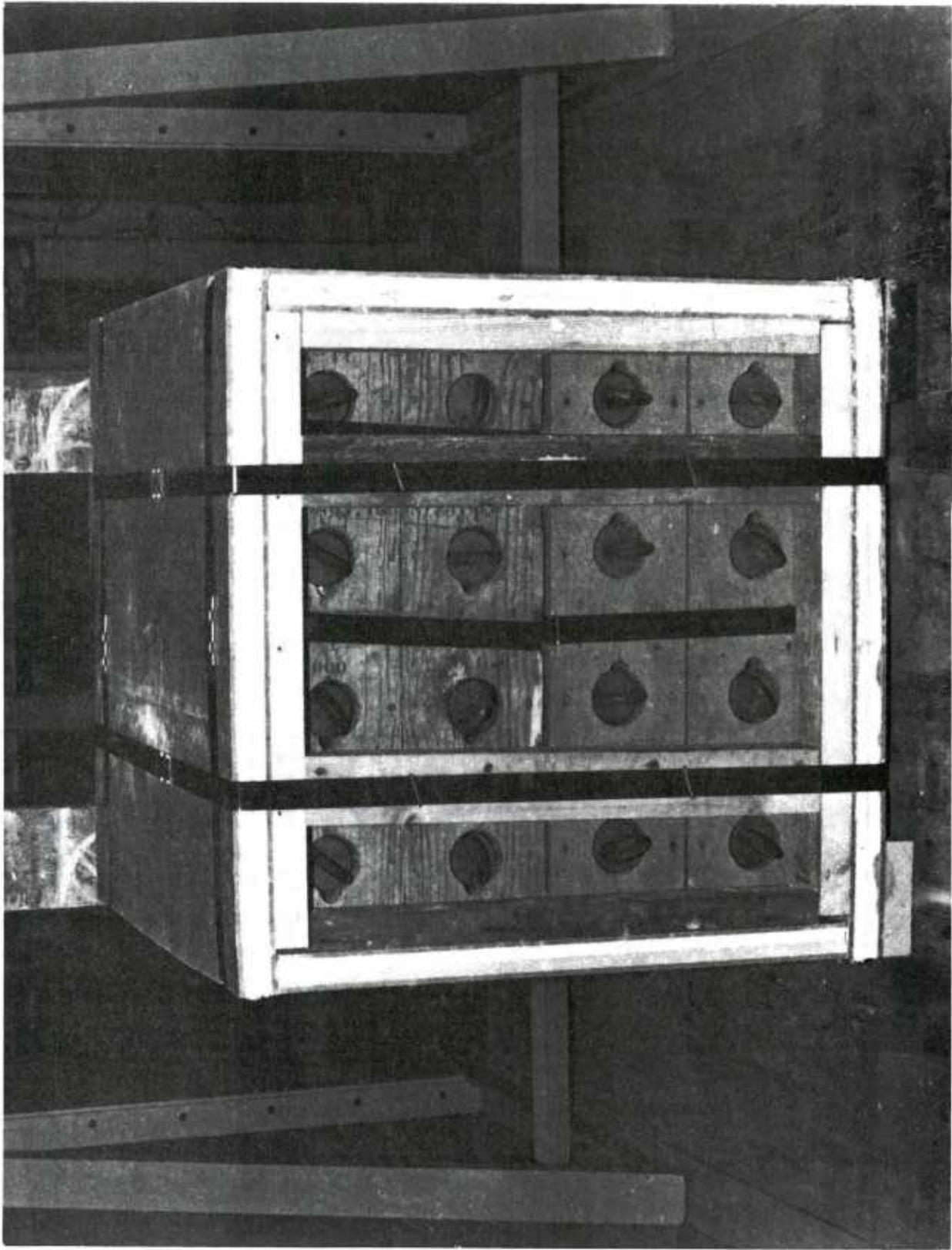

Figure 8 - The shielded 16 round unit, as used in STROM tests.

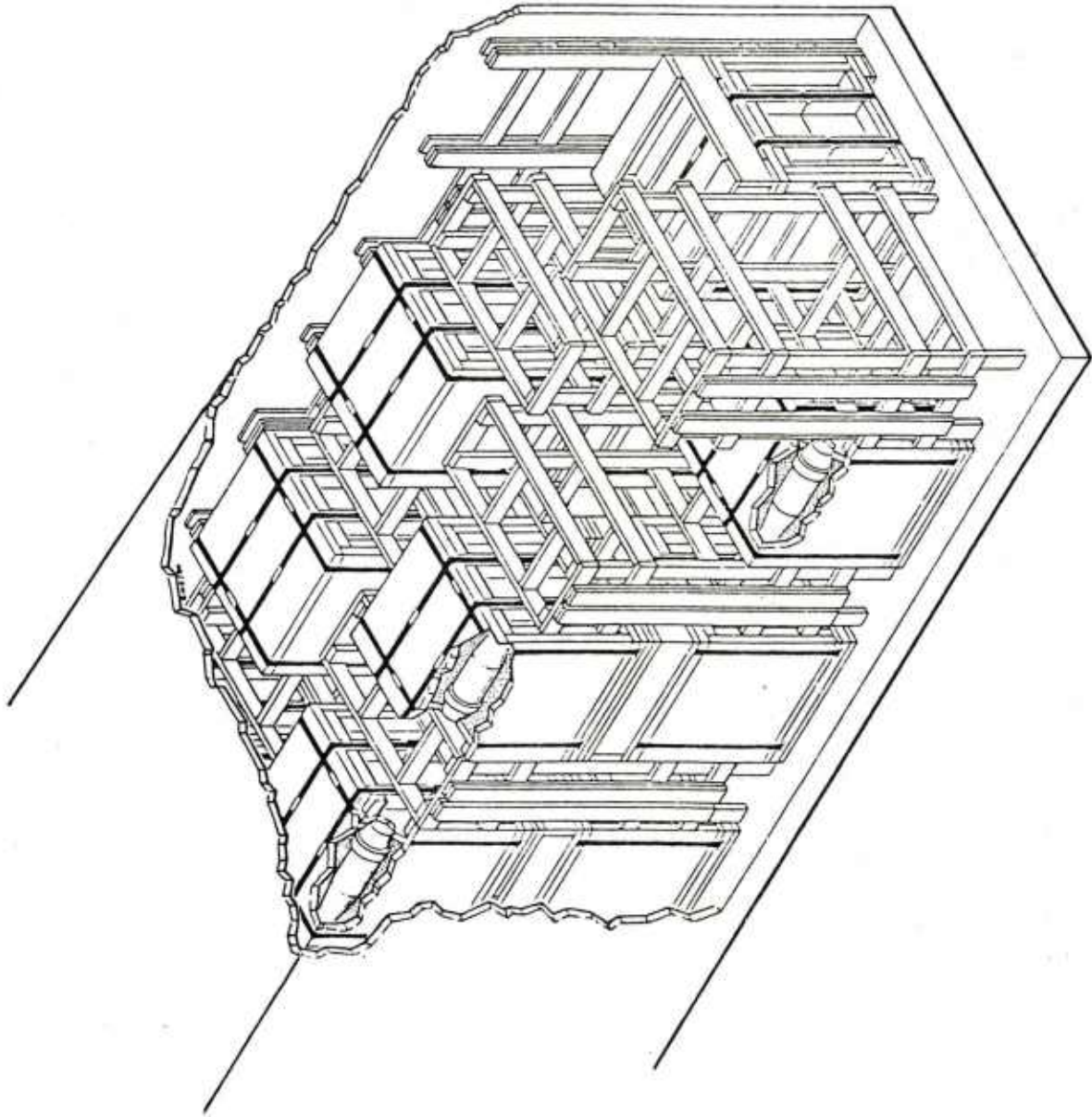

Figure 9 - Sixteen round shielded units configured in standard 20 foot milvan container.

These added costs* will be presented with conventional costs so that comparisons can be made.

[1] Container Leasing Charges. When shipped in the conventional unshielded method, 336 155 mm SLP can be transported in one 20-foot intermodal container. This capacity is predicated upon 42 eight-round pallets utilizing the wood dunnage restraint system in a commercial container. Table I describes estimated container leasing costs when the conventional method is employed. Table II shows that container leasing charges increase when the shielded pallet system is used. SLP capacity is limited to 288 rounds based on 18 shielded pallets of 16 rounds each.

[2] Rail Transportation Costs.

[a] Breakbulk. Rail transportation charges will increase using the shielded pallets. This increase is due primarily to the extra shipping weight of the shielding material and the increased dunnage. The increased number of boxcars required has little effect since charges are based on weight shipped rather than number of cars. Table III details projected rail breakbulk transportation charges for the conventional method of shipping 155 mm SLP in unshielded 8-round pallets. Table IV lists these costs for the proposed 16-round shielded pallet.

* For the purposes of the following cost analyses, the assumptions listed below were made.

1. Shielded pallets have been designed for 155 mm SLP only.
2. ARRCOM ammunition shipments and DESCOM ammunition receipts will utilize shielded pallets.
3. 85% of all ammunition shipped is by rail.
4. 12,000 short tons of ammunition will be shipped in containers by rail annually.
5. Car unloading cost is not affected by shielded pallets. Even though 37% more boxcars are required to transport the shielded units, and a corresponding extra amount is unloaded, unloading costs will not be increased. Unlike loading, unloading is not a strict function of dunnage, and the 16-round shielded pallet can be unloaded quicker than individual 8-round pallets in the break bulk rail shipping mode.
6. Container stuffing times are not increased by the shielded pallets. Even though 14% or six fewer 8-round pallets are loaded per container when the shielded pallet is used, the resulting additional dunnage requirement cancels this reduced loading advantage.
7. Economic analyses will be based on FY 81-85 since ammunition shipping projections have been provided for those years.

TABLE I

FY	CONTAINER LEASING CHARGE			INCREASED CONTAINER LEASING CHARGES
	155mm SLP CONTAINER- IZED TONNAGE*	CONVENTIONAL PALLET CONTAINERS**	LEASING CHARGE/ CONTAINER***	
81	859	52	\$453	\$23,556
82	663	40	498	19,920
83	443	27	548	14,796
84	474	29	603	17,487
85	446	27	663	<u>17,901</u>
TOTAL				\$93,660

* ARRCOM: 155mm SLP tonnage procurement projections are applied to the ARRCOM containerized rail shipment of 12,000 tons annually.

** Based on 33,600 lbs. of 155mm SLP per container.

*** Based on the 1979 average of \$4.74 per diem per leased commercial container from the Military Sealift Command RG-18, page 178, and an ARRCOM supplied average lease interval of 79 days.

TABLE II

CONTAINER LEASING CHARGE

FY	155mm SLP CONTAINER- IZED TONNAGE*	SHIELDED PALLET CONTAINERS**	LEASING CHARGE PER CONTAINER***	ANNUAL CONTAINER LEASING CHARGES
81	859	60	\$453	\$ 27,180
82	663	46	498	22,908
83	443	31	548	16,988
84	474	33	603	19,899
85	446	31	663	20,553
TOTAL				\$107,528

* ARRCOM 155mm SLP tonnage procurement projections are applied to the ARRCOM containerized rail shipment estimate of 12,000 tons annually.

** Based on 28,800 lbs. of 155mm SLP per container.

*** Based on the 1979 average of \$4.74 per diem per leased commercial container from the Military Sealift Command RG-18, page 178, and an ARRCOM supplied lease interval of 79 days. Inflated at 10% per year.

TABLE III

RAIL TRANSPORTATION COSTS - 8-ROUND CONVENTIONAL PALLET

<u>FY</u>	<u>(a) NO. OF BOXCARS REQUIRED*</u>	<u>(b) SHIPPING TONNAGE PER CAR**</u>	<u>(c) SHIPPING RATE/TON***</u>	<u>ANNUAL TRANS- PORTATION COSTS (a x b x c)</u>
81	757	69.50	\$103.20	\$ 5,429,507
82	746	69.50	113.52	5,885,671
83	556	69.50	124.87	4,825,227
84	669	69.50	137.36	6,386,622
<u>85</u>	<u>672</u>	<u>69.50</u>	<u>151.09</u>	<u>7,056,507</u>
TOTAL				\$29,583,534

* From Loading Cost Table

** Based on 138,400 lbs. of pallets and SLP and 595 lbs. of dunnage.

*** General boxcar 1000-mile rate from TEA-ER Quote No. A-6332, "Rate on Ammunition, Explosives, and Ordnance Between Points in ICC Docket 28-300 Territory." Inflated 10% per annum.

TABLE IV

RAIL TRANSPORTATION COSTS - 16-ROUND SHIELDED PALLET

<u>FY</u>	<u>(a) NO. OF BOXCARS REQUIRED*</u>	<u>(b) SHIPPING TONNAGE PER CAR**</u>	<u>(c) SHIPPING RATE/TON***</u>	<u>ANNUAL TRANS- PORTATION COSTS (a x b x c)</u>
81	1212	56.97	\$103.20	\$ 7,125,716
82	1195	56.97	113.52	7,728,345
83	890	56.97	124.87	6,331,321
84	1072	56.97	137.36	8,388,828
<u>85</u>	1076	56.97	151.09	<u>9,261,775</u>
TOTAL				\$38,835,985

* From Loading Cost Table

** Based on 104,814 lbs. of pallets and SLP and 9134 lbs. of dunnage

*** General boxcar 1000-mile rate from TEA-ER Quote No. A-6332, "Rate on Ammunition, Explosives, and Ordnance Between Points in ICC Docket 28-300 Territory." Inflated 10% per annum.

[b] Containerized. Rail transportation costs for the 155 mm SLP portion of the 12,000-ton annual containerized projection should also be compared for the shielded and unshielded shipment methods. Table 5 indicates that from 52 to 27 containers are required to handle the annual 155 mm SLP throughput with the conventional outloading configuration. The 155 mm SLP portion of total ammunition shipments averages 4.46 percent according to ARRCOM projections. Table 6 indicates that from 60 to 31 containers are needed to transport the same quantity of 155 mm SLP when 16-round shielded pallets are employed.

[3] Demurrage Charges. Demurrage is a charge billed by the railroad carrier for railcars which are kept by the shipper or receiver for what are considered unnecessarily long periods of time. By necessitating more cars to ship the same amount of ammunition, the shielded pallet system would logically subject more cars to this charge. Past demurrage charges per car shipped were calculated, and these charges are applied to the increased number of cars required. Tables 7 and 8 depict demurrage charges incurred with the conventional 155 mm SLP shipping method for rail breakbulk and containerized shipping respectively. Tables 9 and 10 display these estimated demurrage costs for the breakbulk and containerized transport of 155 mm SLP in 16-round shielded pallets. Twenty-foot containers are shipped three or four to an 89-foot TTX flatcar, depending if the containers are trailer-mounted.

(b) The 32-round shielded pallet consists of four conventional 8-round 155 mm SLP pallets laid horizontally and then stacked vertically. The shielding material is applied to the top, bottom, and two sides of this 32-round bundle. Twenty-seven of these 32-round shielded pallets can be shipped in a 50 foot 6 inch boxcar, as is shown in Figure 10.

Rail transportation and demurrage costs have an operational impact on the evaluation of this shielded pallet option.

[1] Rail Transportation Costs. Rail breakbulk transportation charges for the 32-round shielded 155 mm SLP pallet are lower in comparison to those costs for the 16-round version. This reduction is due primarily to an approximate 25 percent reduction in the amount of shielding required per round. In addition, less dunnage is required since the lading has a lower profile. Finally, less handling is required since each unit handled contains twice as many SLP. Table 11 summarizes 32-round shielded pallet transportation changes for the FY 81 through FY 85 timeframe.

[2] Demurrage Charges. Demurrage charges resulting from shipping 155 mm SLP in 32-round shielded pallets are similar to those for the 16-round pallet. The only departure from this similarity is that all 32-round pallets would be shipped by rail breakbulk, whereas, 12,000 tons of the 16-round shielded palletized 155 mm SLP would be containerized. Table 12 lists these demurrage costs.

TABLE V

CONVENTIONAL PALLET TRANSPORTATION COST (CONTAINER)

	<u>CONTAINERS SHIPPED *</u>	<u>TONNAGE SHIPPED **</u>	<u>RATE/TON ***</u>	<u>ANNUAL TRANSPORTATION COST</u>
FY 81	52	926	\$ 92.38	\$85,560
82	40	712	101.62	72,398
83	27	481	111.79	53,759
84	29	517	122.96	63,511
85	27	481	135.25	65,041

* Based on 33,600 lbs. of 155mm SLP per container

** Based on 35,622 lbs. of lading per container

*** TEA-ER-Quote No. A-5073-D with 10% annual inflation

TABLE VI

16-ROUND SHIELDED PALLET TRANSPORTATION COST (CONTAINER)

	<u>CONTAINERS SHIPPED*</u>	<u>TONNAGE SHIPPED**</u>	<u>RATE/TON***</u>	<u>TRANSPORTATION COST</u>
FY 81	60	1,127	\$ 92.38	\$104,112
82	46	864	101.62	87,787
83	31	582	111.78	65,076
84	33	620	122.96	76,203
85	31	582	135.25	<u>78,716</u>
TOTAL				\$411,895

* Based on 28,800 lbs. of 155mm SLP per container.

** Based on 37,562 lbs. of lading per container.

*** TEA-ER-Quote No. A-5073-D, 1,000-mile "Rates on Ammunition, Explosives, or Fireworks in MILVAN Containers or Trailers in ICC Docket 28-300 Territory." Inflated 10% annually.

TABLE VII

RAIL BREAKBULK DEMURRAGE CHARGES
8-ROUND CONVENTIONAL PALLET

<u>FY</u>	<u>NO. OF BOXCARS REQUIRED*</u>	<u>AVERAGE DEMURRAGE PER CAR**</u>	<u>ANNUAL DEMURRAGE CHARGES</u>
81	757	\$35.43	\$ 26,821
82	746	38.97	29,072
83	556	42.87	23,836
84	669	47.16	31,550
<u>85</u>	<u>672</u>	<u>51.87</u>	<u>34,857</u>
TOTAL			\$146,135

* From Loading Cost Table

** Based on 1978 and 1979 averages obtained from The Report of Rail Demurrage for ammunition and supplied by MTMC-Eastern Area, Bayonne, N.J.. Inflated at 10% per annum.

TABLE VIII

DEMURRAGE COST (TTX SHIPPING)

FY	CONVENTIONAL PALLET CONTAINERS*	TTX FLATCARS REQUIRED**	DEMURRAGE CHARGES PER CAR***	ANNUAL DEMURRAGE CHARGES
81	52	15	\$35.43	\$ 531
82	40	12	38.97	468
83	27	8	42.87	343
84	29	9	47.16	424
85	27	8	51.87	<u>415</u>
				\$2,181

* From Container Leasing Charge Table.

** Assume 3.5 20-foot containers per TTX car to reflect TOFC capacity of 3 trailers and COFC capacity of 4 containers.

*** Based on 1978 and 1979 averages obtained from The Report of Rail Demurrage for ammunition and supplied by MTMC-Eastern Area, Bayonne, N.J. Inflated at 10% per annum.

TABLE IX

RAIL BREAKBULK DEMURRAGE CHARGES
16-ROUND SHIELDED PALLET

FY	NO. OF BOXCARS REQUIRED*	AVERAGE DEMURRAGE PER CAR**	ANNUAL DEMURRAGE CHARGES
81	1212	\$35.43	\$ 42,941
82	1195	38.97	46,569
83	890	42.87	38,154
84	1072	47.16	50,556
85	1076	51.87	55,812
TOTAL			\$234,032

* From Loading Cost Table

** Based on 1978 and 1979 averages obtained from The Report of Rail Demurrage for ammunition and supplied by MTMC-Eastern Area, Bayonne, NJ. Inflated at 10% per annum.

TABLE X

DEMURRAGE COST (TTX SHIPPING)

<u>FY</u>	<u>SHIELDED PALLET CONTAINERS*</u>	<u>TTX FLATCARS REQUIRED**</u>	<u>DEMURRAGE CHARGES PER CAR***</u>	<u>ANNUAL DEMURRAGE CHARGES</u>
81	60	18	\$35.43	\$ 638
82	46	14	38.97	546
83	31	9	42.87	386
84	33	10	47.16	472
85	31	9	51.87	<u>467</u>
				\$2,508

* From Container Leasing Charge Table.

** Assume 3.5 20-foot containers per TTX car to reflect TOFC capacity of 3 trailers and COFC capacity of 4 containers.

*** Based on 1978 and 1979 averages obtained from The Report of Rail Demurrage for ammunition and supplied by MTMC-Eastern Area, Bayonne, NJ. Inflated at 10% per annum.

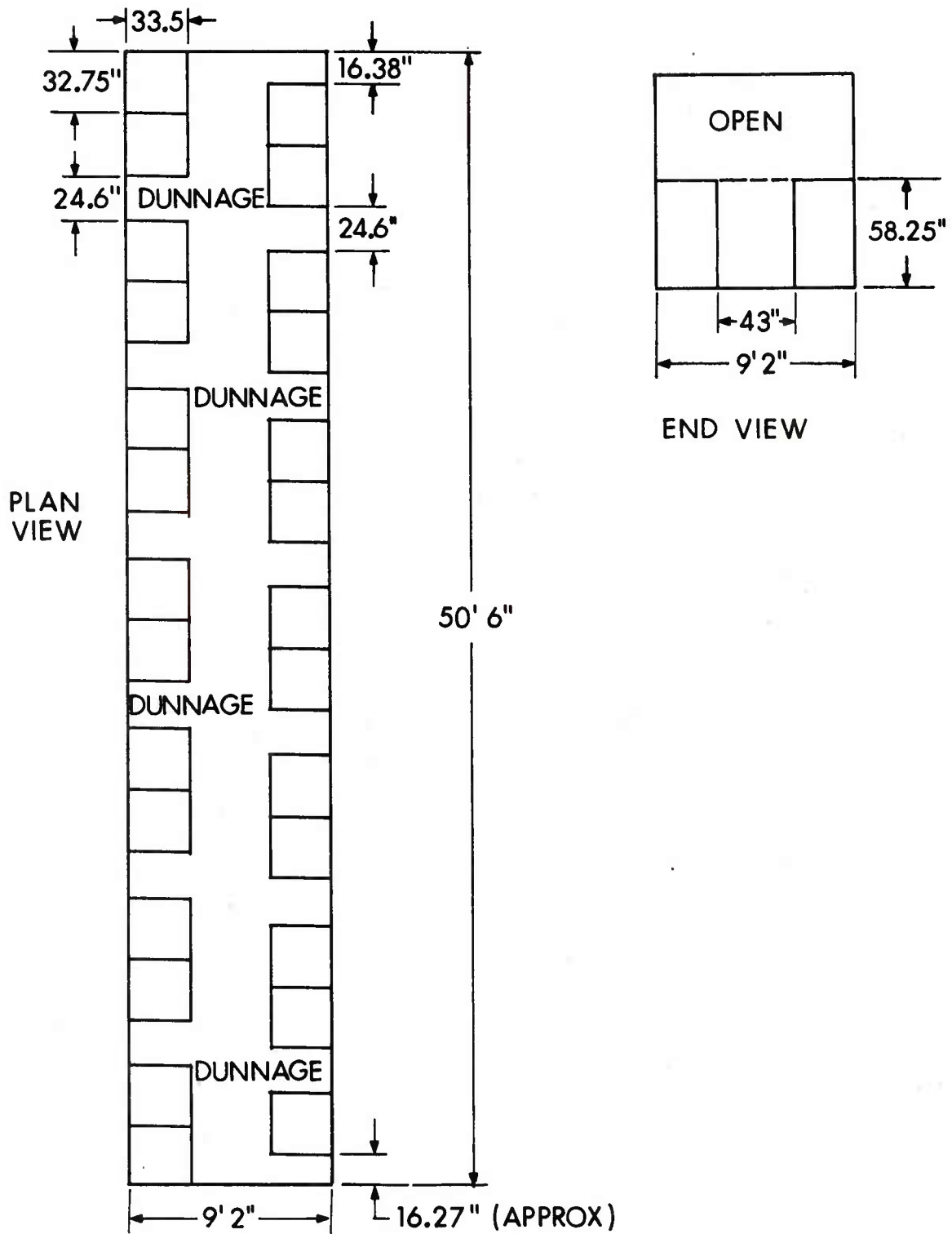

Figure 10 - Schematic configuration of 32-round units on 50 foot 0 inch boxcar.

TABLE XI

RAIL TRANSPORTATION COSTS - 32-ROUND SHIELDED PALLET

<u>FY</u>	<u>(a) NO. OF BOXCARS REQUIRED*</u>	<u>(b) SHIPPING TONNAGE PER CAR**</u>	<u>(c) SHIPPING RATE/TON***</u>	<u>ANNUAL TRANS- PORTATION COSTS (a x b x c)</u>
81	1232	52.55	\$103.20	\$ 6,681,079
82	1211	52.55	113.52	7,223,916
83	900	52.55	124.87	5,905,502
84	1083	52.55	137.36	7,817,087
<u>85</u>	1086	52.55	151.09	<u>8,622,272</u>
TOTAL				\$36,249,856

* From Loading Cost Table

** Based on 101,871 lbs. of pallets and SLP and 3,225 lbs. of dunnage.

*** General boxcar 1000-mile rate from TEA-ER Quote No. A-6332, "Rate on Ammunition, Explosives, and Ordnance between Points in ICC Docket 28-300 Territory." Inflated 10% per annum.

TABLE XII

RAIL BREAK BULK DEMURRAGE CHARGES
32-ROUND SHIELDED PALLET

<u>FY</u>	<u>NO. OF BOXCARS REQUIRED*</u>	<u>AVERAGE DEMURRAGE PER CAR**</u>	<u>ANNUAL DEMURRAGE CHARGES</u>
81	1232	\$35.43	\$ 43,650
82	1211	38.97	47,193
83	900	42.87	38,583
84	1083	47.16	51,074
<u>85</u>	1086	51.87	<u>56,331</u>
TOTAL			\$236,831

* From Loading Cost Table

** Based on 1978 and 1979 averages obtained from The Report of Rail Demurrage for

ammunition and supplied by MTMC-Eastern Area, Bayonne, NJ. Inflated at 10% per annum.

(3) The 64-round unshielded pallet utilizes spacing as the interpallet propagation deterrent. This spacing is shown in Figure 11. This pallet configuration is actually two adjacent 32-round bundles which would be placed separately in the boxcar. This separation is necessary since most forklift equipment would be incapable of handling the combined 6,400-lb plus load. As was the case with the 32-round shielded pallet, rail transportation and demurrage costs are operationally interesting.

[1] Rail Transportation Cost. This cost is further limited since it is not necessary to pay the cost of transporting the heavy shielding and less dunnage material is required. Table 13 outlines the annual rail transportation charges for the 64-round unshielded pallet.

[2] Demurrage Charges. Demurrage costs necessitated by the 64-round unshielded 155 mm SLP pallet are only slightly higher than those for the 32-round shielded pallet. This increase is due to a few more cars required since the per car capacity of the 64-round unit is slightly less. Comparison of Tables 12 and 14 illustrates this situation.

(2) End-Of-Car Water Tank Blast Shields. This intercar propagation prevention device was developed and tested by NWC, China Lake. One Government owned tank would be placed in each end of the carrier's boxcar. Each tank is constructed of 1/4-inch steel and is 9 feet wide by 8 feet high by 1 foot deep and weighs 2,200 lb empty and 6,700 lb loaded. It is therefore placed empty in the car and filled in place. Conversely, the tanks would be emptied prior to unloading of the tanks at the destination. Approximately 3,600 tanks would be required during the first 5 years after adoption of this option. Logistics management of these tanks would be assumed by the Joint Container Control Office at Tobyhanna Army Depot. This control would be accomplished in accordance with AR 55-1. Unit cost of these tanks in 1980 is approximately \$1,430 (\$1,150 material and \$280 labor). Cost areas that have an operational impact include water tank procurement, an increase in the cost of transporting ammunition, the tank retroshipping cost, and the salvage value of these blast shields.

(a) Water Tank Procurement. The total number of water tanks required was determined by applying the ARRCOM ammunition shipping projections of Class A ammunition to an average munition car fill of 129,000 lb per boxcar. Table 15 summarizes the expenditures necessary to build the required inventory of end-of-car water tank blast shields. The water tank and subsequent cost analyses are done on a total ammunition basis since they apply to the whole spectrum of ammunition items.

(b) Ammunition Transportation Cost. This cost is increased since water and water tanks are being shipped at the ammunition rate. Table 16 details the derivation of the increased transportation cost associated with adoption of the end-of-car water tank blast shield system.

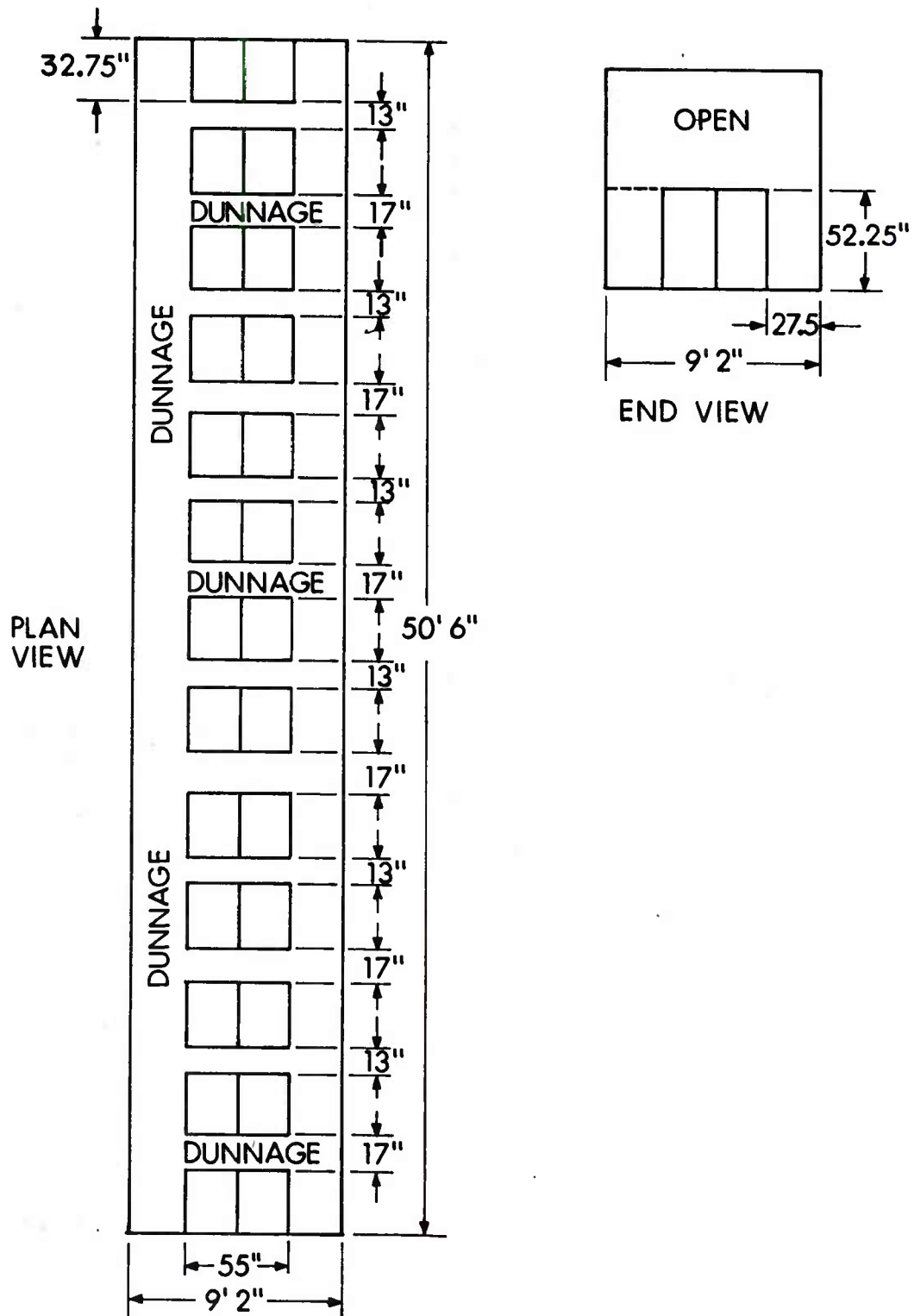

Figure 11 - Boxcar loading diagram for 64-round unshielded 155 mm SLP pallets.

TABLE XIII

RAIL TRANSPORTATION COSTS - 64-ROUND UNSHIELDED PALLET

<u>FY</u>	<u>(a)</u> NO. OF BOXCARS REQUIRED*	<u>(b)</u> SHIPPING TONNAGE PER CAR**	<u>(c)</u> SHIPPING RATE/TON***	<u>ANNUAL TRANS- PORTATION COSTS</u> (a x b x c)
81	1279	48.69	\$103.20	\$ 6,427,246
82	1257	48.69	113.52	6,948,361
83	935	48.69	124.87	5,685,183
84	1124	48.69	137.36	7,517,982
<u>85</u>	1128	48.69	151.09	<u>8,298,881</u>
TOTAL				\$34,877,653

* From Loading Cost Table

** Based on 83,200 lbs. of pallets and SLP and 2,553 lbs. of dunnage.

*** General boxcar 1000-mile rate from TEA-ER Quote No. A-6332, "Rate on Ammunition, Explosives, and Ordnance Between Points in ICC Docket 28-300 Territory." Inflated 10% per annum.

TABLE XIV

RAIL BREAK BULK DEMURRAGE CHARGES
64-ROUND UNSHIELDED PALLET

FY	NO. OF BOXCARS REQUIRED*	AVERAGE DEMURRAGE PER CAR**	ANNUAL DEMURRAGE CHARGES
81	1279	\$35.43	\$ 45,315
82	1257	38.97	48,985
83	935	42.87	40,083
84	1124	47.16	53,008
85	1128	51.87	58,509
TOTAL			\$245,901

* From Loading Cost Table

** Based on 1978 and 1979 averages obtained from The Report of Rail Demurrage for

ammunition and supplied by MTMC-Eastern Area, Bayone, N.J.. Inflated at 10% per annum.

TABLE XV

WATER TANK PROCUREMENT

<u>FY</u>	<u>NO. OF WATER TANKS REQUIRED*</u>	<u>ANNUAL PURCHASE</u>	<u>INFLATED PURCHASE PRICE/TANK (10%/YEAR)</u>	<u>ANNUAL OUTLAY</u>
81	2,030	2,030	\$1,573	\$3,193,190
82	2,634	604	1,730	1,044,920
83	2,944	310	1,903	589,930
84	3,316	372	2,094	778,968
85	3,560	244	2,303	561,932
TOTAL				<u>\$6,168,940</u>

* 2 per munitions boxcar. The number of boxcars is based on ARRCOM ammunition shipping projected tonnages, including DESCOM receipts, less containerized munitions (12,000 tons/year), less motor vehicle shipments, less Class B propelling charge tonnage projections and an average lading of 129,000 lbs per boxcar.

TABLE XVI

INCREASED TRANSPORTATION COST (END-OF-CAR WATER TANKS)

<u>FISCAL YEAR</u>	<u>TOTAL SHIPMENTS*</u>	<u>AMMUNITION TONNAGE SHIPPED**</u>	<u>SHIPPING RATE/TON***</u>	<u>TRANSPORTATION COSTS</u>	<u>INCREASED TRANSPORTATION COST (10.4%)****</u>
FY 81	12,180	785,610	\$114.09	\$ 89,630,245	\$ 9,321,545
82	15,804	1,019,358	125.50	127,929,429	13,304,661
83	17,664	1,139,328	138.05	157,284,230	16,357,560
84	19,896	1,283,292	151.85	194,867,890	20,266,261
85	21,360	1,377,720	167.04	230,134,349	23,933,972

* Based on a car turnaround factor of 12.

** Assume 129,000 lbs per car.

*** Based on the 1,000-mile railroad rate in TEA-ER Quote No. A-5332, "Rates on Ammunition, Explosives, and Ordnance" in ICC Docket 28-300 Territory. The Negotiation Division of MTMC-IN substantiated the 10% inflation factor applied to this rate. The 1000-mile rate is based on MTMC, MT-NFF, letter, 26 Sep 78, subject: Validation of Shipping Volume Data, which states that the average length of a munitions rail line haul is 979.26 miles.

**** The two end of car water tanks weigh 13,400 lbs. filled. This weight represents a 10.4% increase in total tonnage shipped.

(c) Water Tank Retroshipping Cost. When the water tank blast shields have reached their destination, they must then be returned to the ammunition shippers for future use. When an ammunition plant or depot receives a water tank-shielded boxcar, it simply unloads its commodity and reuses the same car, with water tanks in place, to ship an outgoing munitions item. At the end of the CONUS rail transportation network, usually a water terminal shipping point, the water tanks would be removed from the ammunition cars and marshalled until return shipping quantities are generated. Table 17 demonstrates the estimated water tank retroshipping costs for the 5 year projection period.

(d) Water Tank Salvage Value. The salvage value of the water tanks at the end of the project is another operating cost (saving) that must be considered. In Table 18 these steel tanks are costed out as scrap iron at the end of the 5 year project life.

d. Carrier Considerations.

(1) The railroads will have to supply approximately 60 percent more boxcars under the 16-round shielded pallet concept. This increase in car utilization is due to a decrease in per car ammunition capacity due to the volume of the shielding and the spacing requirements. The 32-round shielded pallet system will require approximately 63 percent more boxcars, and the 64-round unshielded configuration will require 69 percent more cars. According to the Association of American Railroads (AAR), over 60,000 boxcars certified for the transport of ammunition are available. Since the present ammunition boxcar requirement totals only 2,000 by FY 85, the boxcar supply appears to be sufficient.

(2) The end-of-car water tank blast shield will not require an appreciable number of extra ammunition-certified boxcars.

(3) Adoption of any of the above intercar explosion propagation prevention options will not require any modification to carrier equipment.

e. Manpower Considerations.

(1) 16 and 32-Round Shielded and 64-Round Unshielded Pallets. These interpallet propagation prevention schemes require increased labor expenditures in the areas of palletization and loading. These added costs will be presented with the costs associated with the conventional 155 mm SLP outloading method so that cost comparisons of the two methods are possible.

(a) Palletization Cost. Manpower requirements associated with this cost category include cutting the hardboard, gypsum, and lumber shielding materials to size and assembling the pallet. Tables 19, 20, and 21 detail the unit costs for the conventional 8-round 155 mm SLP pallet, and 16 and 32-round shielded pallets, and the 64-round unshielded

TABLE XVII

WATER TANK RETROSHIPPING COST

	<u>NO. OF TANKS RETROSHIPPED*</u>	<u>WEIGHT SHIPPED (TONS)**</u>	<u>SHIPPING RATE/TON***</u>	<u>ANNUAL RE-DISTRIBUTION COST</u>
FY 81	19,816	21,798	\$ 86.90	\$1,894,246
82	25,844	28,428	95.59	2,717,433
83	28,916	31,808	105.15	3,344,611
84	32,564	35,820	115.67	4,143,299
85	35,026	38,529	127.23	4,902,102

* Based on 2 tanks per car for ARRCOM ammunition shipping estimates, excluding ARRCOM receipts, containerized munitions, motor vehicle shipments and "Explosives B" shipments.

** Each end-of-car water tank weighs 2,200 lbs.

*** Based on the 976 to 1000-mile railroad rate in TEA-ER Quote No. WTL 3642-D, "Rates for Metal Parts" in ICC Docket 28-300 Territory. The Negotiation Division of MTMC-IN substantiated the 10 percent inflation factor that was applied to this rate.

TABLE XVIII

END-OF-CAR WATER TANK SALVAGE VALUES

<u>FY</u>	<u>NO. OF WATER TANKS</u>	<u>WEIGHT OF WATER TANKS (TONS)</u>	<u>SALVAGE VALUE/TON*</u>	<u>TOTAL SALVAGE VALUE</u>
85	3560	3916	\$72.46	\$283,804

* Estimate supplied by the Defense Logistics Agency Property Disposal Representative at the Savanna Army Depot Activity. This value is inflated by 10 percent per year.

TABLE XIX

PALLETIZATION COSTS/UNIT

8-ROUND CONVENTIONAL PALLET

<u>FY</u>	<u>MATERIAL (INCLUDING 8-ROUND PALLETS)*</u>	<u>LABOR**</u>	<u>TOTAL</u>
81	\$12.82	\$2.51	\$15.33
82	14.10	2.68	16.78
83	15.51	2.87	18.38
84	17.06	3.06	20.12
85	18.76	3.28	22.04

PALLETIZATION COSTS/UNIT

16-ROUND SHIELDED PALLET

<u>FY</u>	<u>MATERIAL (INCLUDING 8-ROUND PALLETS)*</u>	<u>LABOR**</u>	<u>TOTAL</u>
81	\$63.00	\$30.10	\$ 93.10
82	69.30	32.21	101.51
83	76.23	34.46	110.69
84	83.85	36.83	120.68
85	92.23	39.45	131.68

* From Means Co., Inc., Building Construction Cost Data-1980, 38th Annual Edition.

** From the Depot Operations Cost and Receiving Report.

TABLE XX

PALLETIZATION COSTS/UNIT
32-ROUND SHIELDED PALLET

<u>FY</u>	<u>MATERIAL (INCLUDING 8-ROUND PALLETS)*</u>	<u>LABOR**</u>	<u>TOTAL</u>
81	\$103.11	\$41.03	\$144.14
82	113.43	43.91	157.34
83	124.77	46.98	171.75
84	137.24	50.27	187.51
85	150.97	53.79	204.76

* From Means Co., Inc., Building Construction Cost Data-1980, 38th Annual Edition.

** From the Depot Operations Cost and Receiving Report.

TABLE XXI

PALLETIZATION COSTS/UNIT
64-ROUND UNSHIELDED PALLET

<u>FY</u>	<u>MATERIAL (INCLUDING 8-ROUND PALLETS)*</u>	<u>LABOR**</u>	<u>TOTAL</u>
81	\$122.52	\$30.10	\$152.62
82	134.77	32.21	166.98
83	148.25	34.46	182.71
84	163.07	36.83	199.90
85	179.38	39.45	218.83

* From Means Co., Inc., Building Construction Cost Data-1980, 38th Annual Edition.

** From the Depot Operations Cost and Receiving Report. Assume 1 man-hour per pallet pair.

pallets. Table 22 shows the annual quantities of conventional, 16, and 32-round shielded pallets, and 64-round unshielded pallets that have been projected.

(b) Loading Costs.

[1] Breakbulk. Boxcar loading costs are a compilation of dunnage material, dunnage preparation (fabrication), and carloading (ammunition and dunnage placement within the car). Table 24 illustrates these costs for the shipping of the conventional 8-round 155 mm SLP pallet. The spacing requirement of the 16-round shielded pallet car loading configuration demands an enormous amount of dunnage (4,332 board feet) and hence, dunnage preparation (76 man-hours). The results of these cost factors are evident in Table 41, the 16-round shielded 155 mm SLP pallet boxcar loading cost summary. Tables 26 and 27 outline the loading costs for the 32-round shielded and the 64-round unshielded 155 mm SLP pallets respectively.

[2] Containerized. Twenty-foot container loading involves the same components as car loading; i.e., dunnage, dunnage preparation, and load and dunnage placement. Table 28 documents the container loading costs for conventional 8-round pallets of 155 mm SLP. Table 29 displays these costs for the 16-round shielded version of this pallet, which is the only shielded pallet or spaced outloading configuration that has been proposed for containerization.

(2) End-Of-Car Water Tank Blast Shields. This intercar propagation prevention option requires increased manpower costs in the areas of water tank handling, filling and emptying, logistic control, and maintenance.

(a) Water Tank Handling Cost. Due to the weight of these blast shields when they are filled, they must be placed in the boxcar empty and then filled. One water tank is required in each end of the car. Handling operations include retrieval of the tanks from storage, installation and removal from the boxcar, and return to storage. Table 30 is a tabulation of these water tank blast shield handling costs.

(b) Water Tank Emptying and Filling Costs. The massive weight of the filled water tanks (6,700 lb) dictates that they be handled empty. This situation requires that the tanks be both filled and emptied once per complete shipment. Table 31 presents these filling and emptying costs.

(c) Water Tank Logistic Control Cost. If this blast shield option is pursued, the DARCOM Joint Container Control Office (JCCO) at Tobyhanna Army Depot has indicated that it would control the location and movement of these water tanks as it does with the various shipping containers that it presently administers. The computerized control of

TABLE XXII

PALLETIZATION REQUIREMENTS

<u>FY</u>	<u>155mm SLP SHIPPING TONNAGE*</u>	<u>8-ROUND PALLET**</u>	<u>16-ROUND SHIELDED PALLET**</u>	<u>32-ROUND SHIELDED PALLET**</u>	<u>64-ROUND UNSHIELDED PALLET**</u>
81	53,213	133,033	66,516	33,258	16,629
82	52,307	130,768	65,384	32,692	16,346
83	38,897	97,243	48,621	24,311	12,155
84	46,767	116,918	58,459	29,229	14,615
85	46,926	117,315	58,658	29,329	14,664

* ARRCOM Impact Memo

** Based on 100 lbs per 155mm SLP

Table 23 brings together the unit costs of Tables 19 through 21 and the number of pallets of Table 22 and comes up with the comparative annual palletization costs of the four 155mm SLP pallet versions.

TABLE XXIII

PALLETIZATION COSTS
(UNIT COSTS X REQUIREMENTS)

<u>FY</u>	<u>8-ROUND PALLETS</u>	<u>16-ROUND SHIELDED PALLETS</u>	<u>32-ROUND SHIELDED PALLETS</u>	<u>64-ROUND UNSHIELDED PALLETS</u>
81	\$ 2,039,396	\$ 6,192,640	\$ 4,793,808	\$ 2,537,918
82	2,194,287	6,637,130	5,143,759	2,729,455
83	1,787,326	5,381,858	4,175,414	2,220,840
84	2,352,390	7,054,832	5,480,730	2,921,539
<u>85</u>	<u>2,585,623</u>	<u>7,724,085</u>	<u>6,005,406</u>	<u>3,208,923</u>
TOTAL	\$10,959,022	\$32,990,546	\$25,599,117	\$13,618,675

TABLE XXIV

LOADING COSTS (BREAK BULK) - 8-ROUND CONVENTIONAL PALLET

<u>FY</u>	<u>155mm SLP SHIPPING TONNAGE*</u>	<u>NO. OF BOXCARS REQUIRED**</u>	<u>CONVENTIONAL PALLET LOADING COST/BOXCAR***</u>	<u>ANNUAL LOADING COSTS</u>
81	52,354	757	\$342	\$ 258,744
82	51,644	746	369	275,385
83	38,454	556	398	221,166
84	46,293	669	430	287,659
<u>85</u>	<u>46,480</u>	<u>672</u>	<u>464</u>	<u>311,658</u>
TOTAL				\$1,354,612

* ARRCOM Impact Memo projection less containerized 155mm SLP shipments.

** Based on 173 each 8-round pallets weighing 69.2 tons per 50'6" boxcar.

*** Includes dunnage preparation (3.08 M-H) and car loading (5 M-H) inflated at 7%/year and dunnage material (284 BF) inflated at 10%/year.

TABLE XXV

LOADING COSTS (BREAK BULK) - 16 rd SHIELDED PALLET

<u>FY</u>	<u>155mm SLP SHIPPING TONNAGE*</u>	<u>NO. OF BOXCARS REQUIRED**</u>	<u>SHIELDED PALLET LOADING COST/BOXCAR***</u>	<u>ANNUAL LOADING COSTS</u>
81	52,354	1,212	\$5,219	\$ 6,325,428
82	51,644	1,195	5,628	6,725,460
83	38,454	890	6,073	5,404,873
84	46,293	1,072	6,553	7,024,300
<u>85</u>	46,480	1,076	7,072	<u>7,609,033</u>
TOTAL				\$33,089,094

* ARRCOM Impact Memo projection less containerized shipments.

** Based on 54 16-round pallets weighing 43.2 tons per 50'6" boxcar.

*** Includes dunnage preparation (47 M-H) and car loading (76 M-H) inflated at 7%/year and dunnage material (4332 BF) inflated at 10%/year.

TABLE XXVI

LOADING COSTS (BREAK BULK) - 32-ROUND SHIELDED PALLET

<u>FY</u>	<u>155mm SLP SHIPPING TONNAGE*</u>	<u>NO. OF BOXCARS REQUIRED**</u>	<u>SHIELDED PALLET LOADING COST/ BOXCAR***</u>	<u>ANNUAL LOADING COSTS</u>
81	53,213	1232	\$1,942	\$ 2,392,544
82	52,307	1211	2,095	2,537,045
83	38,897	900	2,260	2,034,000
84	46,767	1083	2,438	2,640,354
<u>85</u>	<u>46,926</u>	<u>1086</u>	<u>2,632</u>	<u>2,858,352</u>
TOTAL				\$12,462,295

* ARRCOM Impact Memo Projection. No containerized 155mm SLP will be shipped with this pallet configuration.

** Based on 27 32-round pallets weighing 43.2 tons per 50'6" boxcar.

*** Includes dunnage preparation (17.5 M-H) and car loading (28.38 M-H) inflated at 7%/yr and dunnage material (1613 BF) inflated at 10%/yr.

TABLE XXVII

LOADING COSTS (BREAK BULK) - 64-ROUND UNSHIELDED PALLET

<u>FY</u>	<u>155mm SLP SHIPPING TONNAGE*</u>	<u>NO. OF BOXCARS REQUIRED**</u>	<u>UNSHIELDED PALLET LOADING COST/BOXCAR***</u>	<u>ANNUAL LOADING COSTS</u>
81	53,213	1279	\$1,538	\$ 1,967,102
82	52,307	1257	1,659	2,085,363
83	38,897	935	1,789	1,672,715
84	46,767	1124	1,930	2,169,320
<u>85</u>	<u>46,926</u>	<u>1128</u>	<u>2,084</u>	<u>2,350,752</u>
TOTAL				\$10,245,252

* ARRCOM Impact Memo Projection. No containerized 155mm SLP will be shipped with this pallet configuration.

** Based on 13 64-round pallets weighing 41.6 tons per 50'6" boxcar.

*** Includes dunnage preparation (13.85 M-H) and car loading (22.44 M-H) inflated at 7%/year and dunnage material (1276 BF) inflated at 10%/year.

TABLE XXVIII

CONTAINER LOADING COST - CONVENTIONAL 8-ROUND PALLET

FY	MATERIAL*	LABOR **			TOTAL	NO. OF CONTAINERS***	ANNUAL COST
		DUNNAGE PREPARATION	STUFFING				
81	\$327	\$302	\$186	\$ 815	52	\$42,380	
82	359	322	199	880	40	35,200	
83	395	345	213	953	27	25,731	
84	435	370	228	1,051	29	30,479	
85	478	396	244	1,118	27	30,186	

* From Means Co., Inc., Building Construction Cost Data-1980, 38th Annual Edition.

** From the Depot Operations Cost and Receiving Report.

*** From Table 1

TABLE XXIX

CONTAINER LOADING COSTS-16-ROUND SHIELDED PALLET

	MATERIAL*	LABOR			NO. OF**** CONTAINERS	ANNUAL COST
		DUNNAGE	PREPARATION**	STUFFING***		
FY 81	\$442	\$414	\$186		60	\$ 62,520
82	486	443	199		46	51,888
83	535	474	213		31	37,882
84	588	507	228		33	43,659
<u>85</u>	647	543	244		31	<u>44,444</u>
TOTAL						\$240,393

* Based on 1268 BF of dunnage at \$.31/BF and 29 lbs of nails (DWG. D-SARAC-4359) at \$.314/lb. Inflated at 10%/yr.

** Based on 13.76 M-H (USADACS Time Study). Inflated 7%/yr.

*** Based on 6.18 M-H (USADACS Time Study). Inflated at 7%/yr.

**** Based on 28,800 lbs of 155mm SLP per container.

TABLE XXX

WATER TANK HANDLING COSTS

	CLASS A AMMO SHIP- MENTS (TONS)*	NO. OF BOXCARS AFFECTED**	NO. OF TANKS HANDLED***	LABOR COST PER TANK****	TOTAL HANDLING COSTS
FY 81	639,085	9,908	19,816	\$20.07	\$397,707
82	833,501	12,922	25,844	21.47	554,892
83	932,519	14,458	28,916	22.97	664,185
84	1,050,174	16,282	32,564	24.58	800,412
85	1,129,582	17,513	35,026	26.30	921,178

* ARRCOM receipts are not included because the tanks would be left in cars for future shipments.

** Based on 129,000 lbs of munitions per car.

*** Two tanks per car

**** Estimated at 40 man-minutes to retrieve tank from storage, install, remove, and return to storage.

The cost is based on an estimate of \$30.10 per man-hour in 1981 and inflated at 7% per annum. The

labor charge is projected from the Depot Operation Cost and Performance Report.

TABLE XXXI

WATER TANK FILLING AND EMPTYING COSTS

	<u>NO. OF TANKS FILLED AND EMPTIED*</u>	<u>LABOR COST PER TANK **</u>	<u>ANNUAL FILLING AND EMPTYING COSTS</u>
FY 81	19,816	\$5.02	\$ 99,476
82	25,844	5.37	138,782
83	28,916	5.74	165,978
84	32,564	6.15	200,269
85	35,026	6.58	230,471

* From Handling Cost Table

** Estimated at 10 man-minutes per tank to include connecting and removing water and drain hoses, spotting car at drainage site, and opening and closing water tank bottom drain valve.

these tanks would require the addition of one clerical person to the JCCO staff at the cost indicated in Table 32. This position would be responsible for inputting location and movement data as well as preparing an annual report on the system.

(d) Water Tank Maintenance. During the projected 5 year life of the water tank blast shields, maintenance would be primarily in the form of the repair of leaks. Table 33 details these costs.

f. Cost Considerations.

(1) Each of the intercar explosion propagation prevention options discussed in the Operational and Manpower Considerations sections above was economically analyzed from those two viewpoints. The costs that were generated by this process were then subjected to the present-value analyses. For the conventional 8-round, the 16 and 32-round shielded, and the 64-round unshielded 155 mm SLP pallets the results of these analyses are tabulated in Table 34. The present worth figure brings total life-of-project costs back to their value at the beginning of the project. These estimates represent the relative expenses that would be incurred if the individual ammunition transportation options were adopted.

(2) In order to compare the seven alternatives considered in this subtask, each option must be formulated to apply to the same parameters. The four systems of Table 34 are based only on the 155 mm SLP portion, while the remaining three options were evaluated on a basis of the total DOD ammunition family. Multiplying the latter three alternatives by .0446 (the proportion by weight of the 155 mm SLP portion of the inventory) effectively applies all seven systems to 155 mm SLP only. The economic analysis summary of Table 35 was performed on an incremental basis with the status quo option (conventional 8-round pallets) given a cost of zero. The other options are listed with the increased cost over present operations.

g. Procedures for Logistic Control.

(1) The end-of-car water tank blast shield is the only intercar buffer system considered which would require logistic control. If this blast shield option is pursued, the DARCOM Joint Container Control Office (JCCO) at Tobyhanna Army Depot has indicated that it would control the location and movement of these water tanks as it does with the various shipping containers that it presently administers⁹. The computerized control of these tanks would require the addition of one clerical person to the JCCO staff at the cost indicated in Table 32. This position would be responsible for inputting location and movement data as well as preparing an annual report on the system.

⁹FONECON between J. Kenna (DACS) and Edward McDonough, DARCOM, JCCO, Tobyhanna Army Depot, PA, February 1980.

TABLE XXXII

END-OF-CAR WATER TANK LOGISTIC CONTROL COSTS

<u>FY</u>	<u>ANNUAL CONTROL COST*</u>
81	\$ 32,100
82	34,347
83	36,751
84	39,324
85	<u>42,077</u>
TOTAL	\$184,598

* One clerical person would be required at JCCO to administer the computerized control of the tanks.¹⁴ Inflated at 7% annually.

TABLE XXXIII

END-OF-CAR WATER TANK MAINTENANCE COSTS

<u>FY</u>	<u>NO. OF WATER TANKS</u>	<u>ANNUAL MAINTENANCE COST/TANK *</u>	<u>ANNUAL WATER TANK MAINTENANCE COST</u>
81	2030	\$30.10	\$ 61,103
82	2634	32.31	84,841
83	2944	34.46	101,450
84	3316	36.83	122,128
85	3560	39.45	140,442

* Maintenance requirements are estimated at 1 man-hour per year per water tank.

TABLE XXXIV

155MM SLP* SHIELDED PALLET

<u>ALTERNATIVE</u>	COST SUMMARY		<u>EQUIVALENT ANNUAL COST</u>
		<u>PRESENT WORTH</u>	
A. CONVENTIONAL 8-ROUND PALLET	\$33,562,973	\$ 8,437,148	
B. 16-ROUND SHIELDED PALLET	83,460,790	20,980,591	
C. 32-ROUND SHIELDED PALLET	58,713,518	14,759,557	
D. 64-ROUND UNSHIELDED PALLET	46,445,862	11,675,682	

* Represents approximately 5 percent by weight of all Class A ammunition shipped by rail.

TABLE XXXV

ECONOMIC ANALYSIS SUMMARY

<u>ALTERNATIVE</u>	<u>EQUIVALENT ANNUAL COST (EAC) APPLICABLE TO 155mm SLP SHIPMENTS</u>
A. STATUS QUO	0
B* 16-ROUND SHIELDED PALLET	\$12,543,443
C* 32-ROUND SHIELDED PALLET	6,322,409
D* 64-ROUND UNSHIELDED PALLET	3,238,534
E. END-OF-CAR WATER TANKS	956,470

* 155mm SLP (4.46% of ammo shipments by weight) was the basis of these analyses. The EAC's for the remaining alternatives were therefore multiplied by this factor to accomodate a comparison between systems. Since this is an incremental cost analysis, each EAC represents the extra costs necessitated by that system over and above the status quo. True total ammunition system incremental costs can be approximated by dividing each of the above EAC's by .0446.

(2) Item Description. The end-of-car water tank intercar propagation prevention device was developed and tested by NWC, China Lake. One Government owned tank would be placed in each end of the carrier's boxcar. Each tank is constructed of 1/4-inch steel and is 9 feet wide by 8 feet high by 1 foot deep and weights, 2,200 lb empty and 6,700 lb loaded. Approximately 3,600 tanks would be required during the first 5 years after adoption of this option. Logistics management of these tanks would be assumed by the JCCO⁹. This control would be accomplished in accordance with AR 55-1. NWC, China Lake, has subjected the water tanks to explosive testing.

(3) Method of Installation. Due to the 6,700 lb filled weight of each water tank, the water tanks are placed empty in the car and filled in place. Conversely, the tanks would be emptied prior to unloading of the tanks at the destination.

(a) Skill Level Required. The empty water tanks are placed in each end of the boxcar with a fork lift truck. This material handling equipment is operated by a wage grade fork lift operator. The tanks are filled and emptied with a water hose by a wage grade warehouseman at ammunition depots and his counterparts at ammunition plants and water terminal facilities.

(b) Checks/Tests Required Prior to Operation. No tests are required. Water tank leaks, when present, will be apparent during the filling process. Filling and leak testing in a nonfunctional service environment would be counter-productive. Leak detection during actual filling would not be overly costly in terms of manpower since the ammunition lading would not yet be loaded.

(c) Estimated Time Required. Table 30 is based on an estimated 40 man-minutes to retrieve each tank from storage, install it, remove it as its destination, and return it to storage. This table also lists the total handling costs based on the hourly labor rate projected from the Depot Operation Cost and Performance Report and inflated at 7 percent per annum. Water tank filling and emptying times are estimated at 10 man-minutes per tank in determining the annual costs of Table 31. This time includes handling, connecting, and disconnecting water and drain hoses, spotting the car at the draining site, and opening and closing water tank bottom drain valves.

(4) Maintenance Requirements. Water tank blast shield maintenance is estimated at one man-hour per year per tank in Table 33 and consists primarily of welded leak repairs. Each DOD activity having custody of the water tank equipment requiring repair will effect that repair. Ocean terminals and outports will make only the minimum essential repairs necessary to assure safe retroshipment. Water tanks on loan to other DOD activities maintained and repaired by the using activities as a condition set forth in loan agreements. The following procedures for maintenance of water tanks equipment will apply:

(a) Inspection. To determine serviceability, water tank equipment will be inspected in accordance with applicable Technical Manuals (TM).

(b) Repair. Repairs will be made to the extent necessary to assure that equipment is in an acceptable serviceable condition conforming to standards of applicable TMs. Repair or painting will not be accomplished solely to return the container to a "like new" condition.

(c) Exceeding Repair Limits. Except as specified in load agreements, water tank equipment requiring repair exceeding repair limitations will be serially reported to Director, DARCOMPSCC, Tobyhanna Army Depot, ATTN: SDSTO-TCOC, Tobyhanna, PA 18466, for disposition instructions. The report will include a description of the condition of each water tank and detailed estimated repair costs. Water tank equipment will not be shipped to the Defense property Disposal Office (salvaged) without the prior written direction of DARCOMPSCC (JCCO).

(d) Repair Limits. Repair within specified limits will be affected using local resources or commercial contracts and funded in accordance with AR 750-17. Commanders effecting repair of water tank equipment will furnish DA Form 2407 (Maintenance Request) to JCCO for each completed repair action. DA Form 2407 will be forwarded within 5 working days after closeout.

(5) Shipping Configuration. When the water tank blast shields have reached their destination, they must then be returned to the ammunition shippers for future use. When an ammunition plant or depot receives a water tank-shielded boxcar, it simply unloads its commodity and reuses the same car, with water tanks in place, to ship an outgoing munitions item. At the end of the CONUS rail transportation network, usually a water terminal shipping point, the water tanks would be removed from the ammunition cars and marshalled until return shipping quantities are generated. Table 17 demonstrated the estimated water tank retroshipping costs for the 5 year projection period. These 9 feet wide by 8 feet high by 1 foot deep tanks are fabricated of 1/4-inch steel and weigh 2,200 lb empty. Approximately 45 of these tanks could be retroshipped to a specific ammunition shipment originator per 50-foot boxcar. Rail flatcar may be a more practical mode of retroshipment. These water tanks require no special handling requirements or packaging.

(6) Logistic Control Procedures. All installations, activities, and agencies, regardless of command, location, or service, which receive, transship, or dispatch water tanks (loaded or empty) will report such receipts, transshipments, or dispatches within 48 hours. These reports form the basis for water tank control administered by JCCO and provide the current location or destination of water tank equipment. Movement reports will be electrically transmitted, unclassified, routine messages addressed to CDR TOAD TOBYHANNA PA with an information copy to each

consignee. Multiple transactions may be grouped on a single transmission as long as such grouping does not impede accurate reporting. Water tanks will be reported by US Army serial number.

3. Discussion.

The sequence of options listed on page 30 was listed in order of increasing probable explosion size. Unfortunately, as was seen in the operational feasibility section, this sequence is also ordered according to decreasing costs. Significant increases in cost/munition accrue with implementation of techniques which decrease explosion size.

In Table 36, the Inhabited Building Distance (IBD) and Fragment Distances (FD) are provided for various sizes of explosions of 155 mm artillery shell. (Recall that the IBD is defined as the minimum permissible distance between an inhabited building and an explosive location, that provides a high degree of protection to the building and its occupants from blast or shock effects. The FD is defined as the range to which a hazardous fragment density may extend from the explosion of a particular item of ammunition¹⁰.)

These distance criteria are designed to provide a high level of protection for personnel against blast and primary fragments and for buildings against structural damage. They do not account for glass breakage (and personal injury resulting therefrom) or for throwouts (ejected, intact, or partially intact munitions) and fragments which may cause fires. (The test data gathered under this program would indicate that the danger of fires starting from throwouts and fragments is vanishingly small in the absence of extremely flammable target materials. These tests were conducted on arid terrain, in the presence of considerable dried vegetation. In no instance did fire result from the ejecta of these tests.)

In Figure 12, the uniform annual cost is plotted vs the IBD and FD obtained for the options cited above which are applicable to 155 mm SLP. The water tank option represents a lower bound of estimated costs. Not included in this estimate are costs resulting from required additional spacing (with consequent reduction in payload, and increased dunnage) to prevent propagation from car to car via a crushing mechanism. The "status quo" option IBD represents that for a 10-munition car train, where the

¹⁰AMCR 385-100

TABLE XXXVI

INHABITED BUILDING DISTANCES AND FRAGMENT DISTANCES
FOR VARIOUS SIZES OF EXPLOSIONS OF 155 MM PROJECTILES

Unit Size (pallets)	Inhabited Building Distance		Fragment Radius	
	m	ft	m	ft
2	76	250	457	1500
4	100	330	457	1500
8	128	420	457	1500
48 (1 milivan)	207	680	457	1500
173 (1 50'6" railcar)	335	1100	457	1500
10 cars	853	2800	457	1500

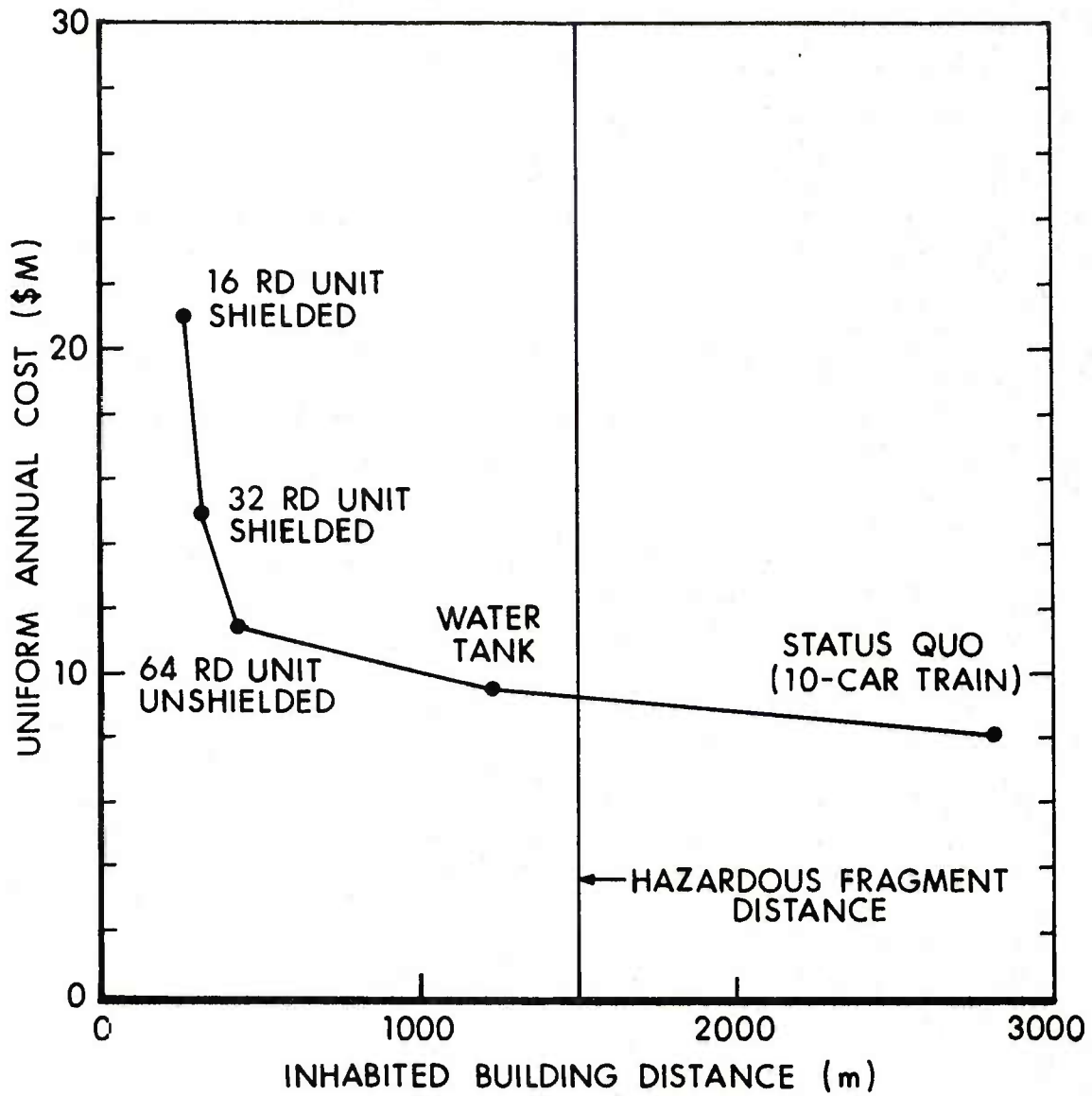

Figure 12 - Uniform annual costs versus inhabited building distance and fragmentation distances for various options.

munition laden cars are contiguous. More munitions cars would increase this distance, of course*.

V. CONCLUSIONS

1. It is technically feasible to control the size of an explosion of mass detonable munitions, by application of several different techniques:

a. Reconfiguration of projectiles such that units are arranged nose-nose and base-base can essentially eliminate propagation of detonation between units, if adequate spacing is maintained.

b. Reconfiguration of MK 80 series bombs, with specially designed nose plugs into a nose-nose configuration can essentially eliminate propagation of detonation between units of bombs, provided adequate spacing between units is maintained.

c. Side to side propagation of detonation between units of projectiles can be essentially eliminated through use of shielding and spacing.

2. The cost per munition, to limit the size of an explosion to a unit of a given size, is inversely proportional to the size of the unit, for shielded units.

3. The use of water tanks at the end of railcars may significantly reduce the tendency for detonation to propagate between carloads of MK 80 series bombs. In combination with appropriate spacing, this approach should be applicable to a wide range of munitions. Test data would have to be obtained, however, for each application. It is unlikely that without increased spacing between carloads these water tanks will prevent propagation of detonation between carloads of projectiles which, because of the sensitivity of the explosive fill, are quite vulnerable to crushing.

* Note that the fragment distance is unaffected by choice of options. This does not mean that the fragment risk to personnel and property is independent of explosion size. Indeed, the fragment threat within this distance would be expected to increase quite dramatically with increasing explosion size. (It is quite possible that the actual distance for which the fragment density exceeds one fragment of 78 joules of energy per 58 square meters will also increase with increasing explosion size. However, the currently used US Standard makes no provision for this and there are no quantitative data available, adequate to justify choice of a different standard.)

ACKNOWLEDGEMENTS

The author especially appreciates the efforts of Mr. Jack Kenna and his colleagues at the US Army Defense Ammunition Center. They performed the entire operational analysis.

The author is also grateful to Mr. David Collis, at New Mexico Institute of Technology, Socorro, New Mexico, who conducted most of the testing and made many important technical contributions.

The efforts of Mr. Jack Pakulak, at Naval Weapons Center, China Lake, California, in testing the nose plug and water tank concepts are also appreciated.

Without the help of these people, successful completion of this task could not have been accomplished.

REFERENCES

1. Oppenheim, A. K., et al, "Blast Waves Generated by Exploding Clouds," Shock Tube & Shock Wave Research, 1978, published by University of Washington, pp 465-473, Proceedings of Symposium.
2. Dobbie, J. and Allan, D., "An Analytical Model to Predict Explosion Propagation," Minutes, DOD Explosive Safety Board, Sixteenth Explosive Safety Seminar, Hollywood by the Sea, FL (1974).
3. Parkinson, A. and Smith, K. T., "T209 Milvan Container Storage Tests Final Report," Toole Army Depot (1975).
4. AMC Regulation 385-100, Change 3, Chapter 17 (1977).
5. Gibbons, Gould, Ballistic Research Laboratory, private communication.
6. Rindner, R. and Forsten, I, "Safety Design Considerations in Munition Plants Layout," ACS Symposium Series, No. 96 (1979).
7. WR52/100, p 26, Naval Ordnance Systems Command.
8. AMCR 385-100 (1977).
9. FONECON between J. Kenna (DACS) and Edward McDonough, DARCOM, JCCO, Tobyhanna Army Depot, PA, February 1980.
10. AMCR 385-100.

APPENDIX A

MULTIPALLET UNITS OF SLP

APPENDIX A

MULTIPALLET UNITS OF SLP

I. Summary of Recommendation

It is recommended that consideration be given to shipping separate loading projectiles in multipallet units, oriented nose-nose and base-base, with major axes of the projectiles parallel to the major axes of the rail cars, and with appropriate space between units.

II. Implementation Method

This recommendation would be implemented in two parts.

A. A DOD sponsored study to determine the optimum stacking and spacing configurations for separate loading projectiles, other than 155 mm (the necessary testing has been accomplished for 155 mm munitions), and a cost benefit analysis.

B. A DOD directed implementation of this shipping technique.

III. Actions Required by ASA (IL & FM) and the ASD (MRA & L)

A. ASA (IL & FM) - Review, approve, and forward to ASD (MRA & L) the attached plan.

B. ASD (MRA & L) - Approve the attached plan, provide the necessary funding, direct an appropriate DOD component to coordinate and conduct the program. If deemed warranted by the results of the program, direct the appropriate DOD component to implement program recommendations.

IV. Cost Benefit Summary

A. Estimated net project cost - \$1200K (exclusive of munitions costs)

B. Estimated implementation cost - unknown, would result from A.

C. Summary of benefits. The benefits to be derived lie in the area of improved public safety, which stem from the fact that the maximum credible explosion size is essentially one multipallet unit of munitions, rather than a whole rail car load or an entire munitions train.

V. Operational Impact Summary

There is no projected operational impact.

VI. Logistic Procedural Summary

Implementation of this concept would not require any new management programs or procedures, since cars would be procured according to current procedures.

APPENDIX B

TEST PLAN FOR MULTIPALLET UNITS FOR SLP

APPENDIX B

TEST PLAN FOR MULTIPALLET UNITS FOR SLP

I. Objective

To extend the multipallet unit concept, developed for 155 mm projectiles, to other members of the SLP family, such that significant improvements in public safety can obtain.

II. Participants

DARCOM is judged to be appropriate to assume responsibility for management and performance of this effort. Both ARRADCOM and ARRCOM should be involved.

III. Time Frame

Start - 3d Quarter FY 81
Complete - 4th Quarter FY 82

IV. Resource Requirements

Estimated total cost -	\$1200K (exclusive of costs of munitions)
Materials costs	\$ 200K
Manpower	\$1000K

V. Suggested Facility Participation

Ammunition Equipment Office, Tooele Army Depot, Tooele, Utah
USA Defense Ammunition Center, Savanna, Illinois
USA ARRADCOM Packaging Lab, Dover, New Jersey
USA Ballistic Research Laboratory, Aberdeen Proving Ground, Maryland

VI. Test and Evaluation Methodology

A. Analyses and tests to determine technically feasible configurations for each member of the SLP family. This involves selection of space and weight efficient configurations, and testing of selected options to insure that propagation between units can be prevented.

B. Economic analysis. This involves a complete economic impact assessment, as was done in the bulk of the Task 10 report, to insure that no untoward penalties arise, and to permit an accurate cost-benefit assessment.

APPENDIX C

CONTROL OF EXPLOSIVE SIZE FOR MK 80 SERIES BOMB

APPENDIX C

CONTROL OF EXPLOSIVE SIZE FOR MK 80 SERIES BOMB

I. Summary of Recommendation

It is recommended that a test series be conducted to determine the applicability of nose plugs and nose-nose, base-base orientation, with interpallet spacing, to MK 80 series bombs, to limit explosion size to a single multipallet unit.

II. Implementation Method

This recommendation would be implemented in two parts.

A. A DOD sponsored test program to evaluate technical and operational feasibility followed by, if warranted -

B. A DOD directive for implementation.

III. Actions Required by ASA (IL & FM) and the ASD (MRA & L)

A. ASA (IL & FM) - Review attached plan and submit to ASD (MRA & L).

B. ASD (MRA & L) - Approve the attached plan, identify funding sources, designate the appropriate DoD component to conduct and coordinate the evaluation. If deemed warranted, direct the appropriate DOD component to initiate implementation of study recommendations.

IV. Cost Benefit Summary Statement

A. Project costs -	Total	\$900K
	Manpower	\$800K
	Materials*	\$100K

*exclusive of munitions

B. Benefits. Assessment of potential to dramatically improve public safety in rail transport of bombs.

V. Operational Impact

There is no projected operational impact.

VI. Logistic Procedural Impact

There is no impact on logistic procedures.

APPENDIX D

TEST PLAN FOR CONTROL OF EXPLOSIVE SIZE OF MK 80 SERIES BOMB

APPENDIX D

TEST PLAN FOR CONTROL OF EXPLOSIVE SIZE OF MK 80 SERIES BOMB

I. Objective

To determine the technical and operational feasibility of limiting explosions of MK 80 series bombs to a single, multipallet unit.

II. Participants

Recommend that DARCOM be the lead command. Sub elements of DARCOM will assist at the discretion of DARCOM.

III. Time Frame

Start - 3d Quarter FY 81
Complete - 4th Quarter FY 82

IV. Resource Requirements

Total Costs	\$900K
Materials*	\$100K
Manpower	\$800K

*exclusive of munitions costs

V. Proposed Facility Participation

Ammunition Equipment Office, Tooele Army Depot, Tooele, Utah
USA Defense Ammunition Center, Savanna, Illinois
USA ARRADCOM Packaging Lab, Dover, New Jersey
USA Ballistic Research Laboratory, Aberdeen Proving Ground, Maryland

VI. Test and Evaluation Methodology

A. Scaling analyses of blast, fragment fields for each munition type (MK 82, 83, 84 and GP bombs) as function of unit size will be made to estimate required spacings to prevent propagation between units.

B. Tests will be conducted to demonstrate that explosion can be limited to a single, multipallet unit, and to determine required inter unit spacing. Best configurations will be selected for -

C. Cost and operational analysis.

D. Conclusions and recommendations will be forwarded through channels to ASA (IL & FM) for approval and submission to ASD (MRA & L).

DISTRIBUTION LIST

<u>No. of</u> <u>Copies</u>	<u>Organization</u>	<u>No. of</u> <u>Copies</u>	<u>Organization</u>
12	Commander Defense Technical Info Center ATTN: DDC-DDA Cameron Station Alexandria, VA 22314	1	Commander US Army Communications Rsch and Development Command ATTN: DRDCO-PPA-SA Fort Monmouth, NJ 07703
1	Commander US Army Materiel Development and Readiness Command ATTN: DRCDMD-ST 5001 Eisenhower Avenue Alexandria, VA 22333	1	Commander US Army Electronics Research and Development Command Technical Support Activity ATTN: DELSD-L Fort Monmouth, NJ 07703
4	Commander US Army Armament Research and Development Command ATTN: DRDAR-TSS (2 cy) DRDAR-LCE, Dr. R.F.Walker DRDAR-LCE, Dr. N. Slagg Dover, NJ 07801	1	Commander US Army Missile Command ATTN: DRDSMI-R Redstone Arsenal, AL 35809
1	Commander US Army Armament Materiel Readiness Command ATTN: DRSAR-LEP-L, Tech Lib Rock Island, IL 61299	1	Commander US Army Missile Command ATTN: DRSMI-YDL Redstone Arsenal, AL 35809
1	Director US Army ARRADCOM Benet Weapons Laboratory ATTN: DRDAR-LCB-TL Watervliet, NY 12189	1	Commander US Army Missile Command ATTN: DRSME-RK, Dr. R.G. Rhoades Redstone Arsenal, AL 35809
1	Commander US Army Aviation Research and Development Command ATTN: DRDAV-E 4300 Goodfellow Boulevard St. Louis, MO 63120	1	Commander US Army Tank Automotive Rsch and Development Command ATTN: DRDTA-UL Warren, MI 48090
1	Director US Army Air Mobility Research and Development Laboratory Ames Research Center Moffett Field, CA 94035	1	Director US Army TRADOC Systems Analysis Activity ATTN: ATAA-SL, Tech Lib White Sands Missile Range NM 88002
		1	Commander US Army Research Office ATTN: Chemistry Division P.O. Box 12211 Research Triangle Park, NC 27709

DISTRIBUTION LIST

<u>No. of</u> <u>Copies</u>	<u>Organization</u>	<u>No. of</u> <u>Copies</u>	<u>Organization</u>
1	Commander Office of Naval Research ATTN: Dr. J. Enig, Code 200B Arlington, VA 22217	1	Commander Fleet Marine Force, Atlantic ATTN: G-4 (NSAP) Norfolk, VA 23511
1	Commander Naval Sea Systems Command ATTN: Mr. R. Beauregard, SEA 64E Washington, DC 20362	1	Commander AFRPL ATTN: Mr. R. Geisler, Code AFRPL MKPA Edwards AFB, CA 93523
1	Commander Naval Explosive Ordnance Disposal Facility ATTN: Technical Library Code 604 Indian Head, MD 20640	1	Commander Ballistic Missile Defense Advanced Technology Center ATTN: Dr. David C. Sayles P.O. Box 1500 Huntsville, AL 35808
1	Commander Naval Research Lab ATTN: Code 6100 Washington, DC 20375	1	Director Lawrence Livermore National Lab University of California ATTN: Dr. M. Finger Livermore, CA 94550
1	Commander Naval Surface Weapons Center ATTN: Code G13 Dahlgren, VA 22448	1	Director Los Alamos National Lab ATTN: Dr. B. Craig, M Division P.O. Box 1663 Los Alamos, NM 87545
8	Commander Naval Surface Weapons Center ATTN: Mr. L. Roslund, R122 Mr. M. Stosz, R121 Code X211, Lib E. Zimet, R13 R.R. Bernecker, R13 J.W. Forbes, R13 S.J. Jacobs, R10 K. Kim, R13 Silver Spring, MD 20910		<u>Aberdeen Proving Ground</u> Dir, USAMSAA ATTN: DRXSY-D DRXY-MP, H. Cohen Cdr, USATECOM ATTN: DRSTE-TO-F Dir, USACSL, Bldg 3516, EA ATTN: DRDAR-CLB-PA
4	Commander Naval Weapons Center ATTN: Dr. L. Smith, Code 3205 Dr. A. Amster, Code 385 Dr. R. Reed, Jr., Code 388 Dr. K. J. Graham, Code 3835 China Lake, CA 93555		

USER EVALUATION OF REPORT

Please take a few minutes to answer the questions below; tear out this sheet, fold as indicated, staple or tape closed, and place in the mail. Your comments will provide us with information for improving future reports.

1. BRL Report Number _____

2. Does this report satisfy a need? (Comment on purpose, related project, or other area of interest for which report will be used.)

3. How, specifically, is the report being used? (Information source, design data or procedure, management procedure, source of ideas, etc.) _____

4. Has the information in this report led to any quantitative savings as far as man-hours/contract dollars saved, operating costs avoided, efficiencies achieved, etc.? If so, please elaborate.

5. General Comments (Indicate what you think should be changed to make this report and future reports of this type more responsive to your needs, more usable, improve readability, etc.) _____

6. If you would like to be contacted by the personnel who prepared this report to raise specific questions or discuss the topic, please fill in the following information.

Name: _____

Telephone Number: _____

Organization Address: _____

