



National Research
Council Canada

Conseil national
de recherches Canada

2

A PERFORMANCE EVALUATION OF A LONG LOAD STEERING TRI-AXLE DOLLY ON THE ALASKA HIGHWAY, 1981

by

J.H.F. Woodrooffe

Division of Mechanical Engineering

OTTAWA
JULY 1981

DISTRIBUTION STATEMENT A
Approved for public release;
Distribution Unlimited

DTIC
ELECTE
MAY 19 1982
S H D

MECHANICAL ENGINEERING REPORT

MI-839

NRC NO. 19664

Canada

DTIC FILE COPY

12

**A PERFORMANCE EVALUATION OF A LONG LOAD STEERING TRI-AXLE DOLLY
ON THE ALASKA HIGHWAY, 1981**

**ÉVALUATION DU RENDEMENT D'UN CHARIOT À TUBES À TROIS ESSIEUX,
DONT UN ESSIEU DIRECTEUR ASSERVI, SUR L'AUTOROUTE DE L'ALASKA EN 1981**

by/par

J.H.F. Woodrooffe

**DTIC
SELECTE
MAY 19 1982
S H D**

DISTRIBUTION STATEMENT A
Approved for public release;
Distribution Unlimited

C.A.M. Smith, Head/Chef
Railway Laboratory/
Laboratoire de technique ferroviaire

E.H. Dudgeon
Director/Directeur

ABSTRACT

A road test has been conducted on a highway transporter designed to carry three, 80-foot lengths of 48-inch diameter steel pipe on the Alaska Highway. The transporter uses a tri-axle forced steering dolly which has shown the capacity of significantly reducing the off tracking of the vehicle during curving.

The curving dynamics of the vehicle, as they relate to off tracking, are discussed and the processed data from the test are presented.

SOMMAIRE

Des essais routiers ont été effectués sur un camion conçu pour le transport de trois tubes d'acier de 48 pouces de diamètre et de 80 pieds de longueur sur l'autoroute de l'Alaska. Ce camion est muni d'un chariot à triple essieux auto-braquage qui réduit de façon significative la déviation latérale dans la courbe.

Le comportement dynamique du véhicule relatif à la déviation latérale ainsi que l'analyse des données recueillies au cours des essais ont été traités.



Accession For	
NTIS GRA&I	<input checked="" type="checkbox"/>
DTIC TAB	<input type="checkbox"/>
Unannounced	<input type="checkbox"/>
Justification	<input type="checkbox"/>
<i>FL-58 on file</i>	
By	
Distribution/	
Availability Codes	
Dist	Avail and/or Special
<i>A</i>	

CONTENTS

	Page
SUMMARY	(iii)
TABLES	(v)
ILLUSTRATIONS	(v)
APPENDICES	(vi)
1.0 INTRODUCTION	1
2.0 TRANSPORTER DESCRIPTION	1
2.1 Vehicle Specifications	2
2.2 Steering Principle of the Dolly	3
2.3 Jack-knifing	4
3.0 TEST PROGRAM	5
3.1 Parameters Measured	5
3.2 Instrumentation	7
3.3 Calibration of Transducers and Vehicle Components	11
3.3.1 Pitch and Roll Meter	11
3.3.2 Accelerometers	11
3.3.3 Extensometers	11
3.3.4 Tractor Steering	11
3.3.5 Tractor Fifth Wheel	11
3.3.6 Dolly Turntable	11
3.3.7 Vehicle Displacement Transducer	14
4.0 DEVELOPMENT OF THE KINEMATIC MATHEMATIC EXPRESSIONS	14
4.1 Steady State Kinematic Curving Analysis	15
5.0 CALIBRATION RUN	20
5.1 Calibration Run Results	21
6.0 HIGHWAY TEST RESULTS	28
6.1 Dawson Creek Traffic Circle	28
6.2 Steamboat Switch Back	31
6.3 Roll Angle and Lateral Acceleration Results	32
6.4 Road Test Comments	32
7.0 THEORETICAL COMPARISON OF THE DOLLY WITH RESPECT TO A SEMI-TRAILER	32
8.0 CONCLUDING REMARKS	33

CONTENTS (Cont'd)

	Page
9.0 REFERENCES	34
10.0 ACKNOWLEDGMENTS	34

TABLES

Table		Page
1	Data as Measured by Hand (Actual)	21
2	Measured and Calculated near Peak Values of Off Tracking and the Radii Scribed	26
3	Differences between Calculated and Actual Off Tracking and Curve Radii	26
4	Comparison between Actual and Theoretical Steady State Curving	27
5	Comparison of Actual Off Tracking Results with those Determined Graphically from the 100 Ft. Calibration Tests	28
6	Radius of Curvature as Determined from Tractor Steering Angle and the Off Tracking Determined Graphically	32
7	Theoretical Comparison of Off Tracking and Swept Area between Steering Dolly and a Semi-trailer	33

ILLUSTRATIONS

Figure		Page
1	Fully Loaded Vehicle as Tested	1
2	Schematic of Loaded Tractor and Dolly Showing the Pinned-Pinned Pipe Connection	2
3	Schematic Diagram of the Steering System Tested	3
4	Load Distribution on Tractor and Dolly	5
5,6	Physical Measurement of Vehicle Off Tracking	6
7	Schematic of Instrumentation Layout	8
8	Tractor Steering Calibration	9
9	Tractor Fifth Wheel Calibration	10
10	Dolly Turntable to Steering Angle Calibration	12

ILLUSTRATIONS (Cont'd)

Figure		Page
11	Dolly Turntable Angle to Voltage Calibration	13
12	Kinematic Curving Diagram of a Bicycle	14
13	Kinematic Curving Diagram of a Tractor	15
14	Kinematic Curving Diagram of the Dolly	16
15	Illustration for Trigonometric Solution	17
16	Combined Graphical Solution of Vehicle in Steady State Curving	18
17	Combined Graphical Solution of Vehicle during Non-Steady State Curving ...	19
18	Illustration of the Calibration Curve	20
19	Actual and Calculated Off Tracking 100 Ft. Left Curve	22
19A	Actual and Calculated Off Tracking 100 Ft. Right Curve	23
20	Actual and Calculated Off Tracking 200 Ft. Left Curve	24
20A	Actual and Calculated Off Tracking 200 Ft. Right Curve	25
21	Dawson Creek Traffic Circle	29
22	Graphical Solution Used to Solve for Off Tracking Knowing the Angle of the Load to the Tractor	30
23	Aerial Photograph of the Switch Back Curve at Steamboat	31
APPENDIX A	35
APPENDIX B	39

A PERFORMANCE EVALUATION OF A LONG LOAD STEERING TRI-AXLE DOLLY ON THE ALASKA HIGHWAY, 1981

1.0 INTRODUCTION

With the construction of the Alaska Natural Gas Pipeline, vast quantities of large diameter steel pipe must be transported over portions of the Alaska Highway to the construction site. By pre-welding two standard 40-foot joints¹ of pipe and shipping them as 80-foot nominal joints, there is an economic saving and, more importantly, this will minimize the number of loads required to be transported, thus enhancing safety and minimizing socio-economic impact. Shipping these long joints will require the use of steering trailer or complex trailer assemblies to negotiate the very sharp and narrow curves encountered on the Alaska Highway.

Foothills Pipeline (Yukon) Co., Calgary, in consultation with the British Columbia Ministry of Transportation and Highways, has contracted NRCC to conduct a road test on the Alaska Highway of a tractor-steering trailer assembly that may be used to haul this pipe in the future.

The purpose of the test, therefore, is to provide facts and data on the road performance of a particular vehicle that will enable the parties to determine if this transporter can safely negotiate the Alaska Highway.

It should be recognized that no attempt has been made to analyze the stability limits of this vehicle during such instances as evasive manoeuvring, emergency braking or excessive cornering speeds.

The British Unit System has been chosen for this report because it is the system that much of the trucking industry is currently using. In addition, it was requested that the data be compatible with that of the SAE handbook which also uses the British System.

2.0 TRANSPORTER DESCRIPTION



FIG. 1: FULLY LOADED VEHICLE AS TESTED

¹ A joint is the terminology used in the pipeline industry to describe a single length of pipe.

The transporter or rig² tested, consisted of a standard highway tractor followed by a unique tri-axle forced steering dolly manufactured by Auto Steering Trailers Ltd. (ASTL) of Oakville, Ontario, Canada, shown in Figure 1. The pipe acts as a rigid, pinned-pinned link joining the tractor at the fifth wheel³ to the dolly at its turntable as shown in Figure 2. Since the pipe has sufficient structural integrity

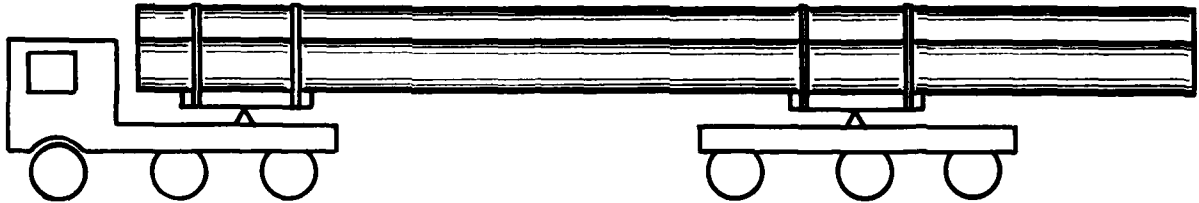

FIG. 2: SCHEMATIC OF LOADED TRACTOR AND DOLLY SHOWING THE PINNED-PINNED PIPE CONNECTION

to act as the trailer bed frame, the structural complexity of the trailer is greatly reduced and the payload increased due to the weight savings in the transporter. The specifications of the dolly are as follows:

2.1 Vehicle Specifications

Tractor

Manufacturer	Freightliner Manufactured May 1980 Model FLT 9664T
Type	Cab over
Wheelbase	174 inches, as measured from the front axle to the centre of the tandem axles
Tandem axle spacing	55 inches
Fifth wheel setting	5 inches negative (aft of the tandem axles centre)
Tires	FRONT: Michelin Regroovable 11T24.5xZA Tubeless LRG 90 psi REAR: Michelin Regroovable 11R24.5xM+S4 Tubeless LRG 90 psi

Dolly

Manufacturer	ASTL (Auto Steering Trailers)
Number of axles	Three (3)
Axle spread	138 X 54*
Wheels per axle	Four (4)
Steering axle (front)	ASTL EHLS 9000 kingpin forced steering axle
Toe in	0°
Caster	0°

* The distance from the first axle to the second, being 138 inches, and from the second to the third, 54 inches.

² Rig is a term used by the trucking industry to denote a tractor trailer assembly.

³ The 5th wheel is the coupling assembly on the tractor about which a semi-trailer pivots.

Front axle suspension
Rear bogie suspension
Tracking

Tires

Reyco 21B, steel leaf suspension
Reyco 21B, tandem axle suspension
77 inches centre to centre of dual wheels, 101½ inches to tire outermost side walls
General Tire Power Jet Regroovable 10:00 20, Nylon Sidewall 12 Nylon Plies, Tread 8 Nylon Plies, Tube, 90 psi

Load

Load width	96-3/4 inches
Load length overall	79 feet 8 inches
Load height -road to bottom of pipe	64½ inches
Road surface to top of pipe	155½ inches

2.2 Steering Principle of the Dolly

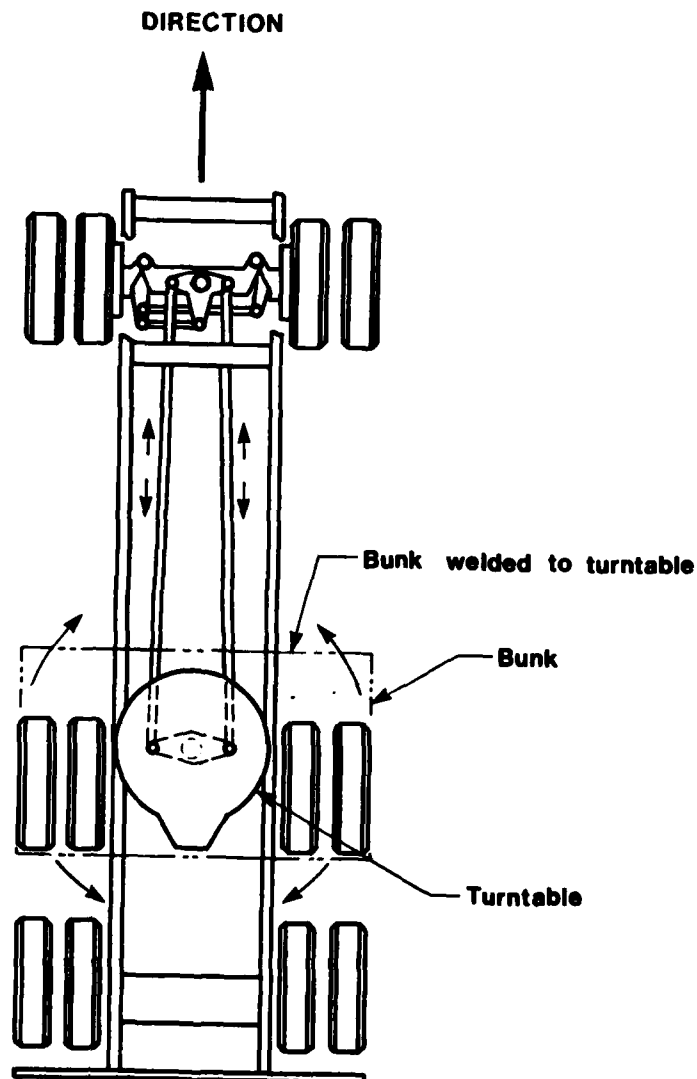

FIG. 3: SCHEMATIC DIAGRAM OF THE STEERING SYSTEM TESTED

The geometry and steering principle of the ASTL tri-axle steering dolly is not unlike that of a standard highway tractor. It consists of a front steering axle and a trailing tandem axle bogie with a steering axle to bogie centre wheel base of 165 in⁴. The wheels of the steering axle are connected through a steering arm assembly to the turntable, to which the load is fixed as shown in Figure 3. When a curve is encountered, the load, and therefore the turntable rotate with respect to the dolly thereby changing the angle of attack of the wheels on the dolly's steering axle. The steering ratio of the turntable to the steering angle of the wheels is constant throughout its sweep at 1:625.

Returning to the analogy between a highway tractor and the steering dolly, one can now appreciate that the external steering dynamics of the dolly are similar to those of a coasting, loaded highway tractor. Instead of a driver operating the steering wheel of the dolly, the angular displacement of the pipe steers the dolly. The analogy does not hold, however, for jack-knifing.

2.3 Jack-knifing

The term jack-knifing refers to a tractor, or in this case, a dolly, which yaws beyond the boundary of steering control, thereby turning back into the trailer not unlike a blade folding back into a jack-knife.

To aid the general reader in an understanding of the jack-knifing comparison between the tractor and dolly, a brief discussion, as presented by ERVIN et. al. (Ref. 1) on the mechanics of the yaw instability leading to jack-knifing will follow.

"A tire side force is the force the road surface exerts on a tire in a direction perpendicular to the plane of the wheel. A vehicle traversing a curve maintains yaw stability if the side forces generated by the rear tires are sufficient to hold the tires on the curve path nominally established by the front tires. The greater the vertical load on an axle, the greater the combined side forces the tires on that axle must generate. The capacity of a tire to generate side force, called the cornering stiffness, is not a constant; it varies with the vertical load on the tire. As the vertical load increases, the cornering stiffness increases. But the relationship is not linear. For example, when the vertical load on a truck tire increases from 5,000 to 8,000 lbs., its cornering stiffness increases by, say, 200 units. But when the vertical load decreases from 5,000 to 2,000 lbs., the cornering stiffness decreases by 300 units. Thus, when a heavy vehicle traversing a curve transfers some of the vertical load on an axle — removes some from the tire on the inside of the curve and adds it to the tire on the other end of the axle — there is a net loss in the combined side force provided by those two tires.

That net loss for tires on the rear axle of a tractor pulling a loaded semi-trailer can be large because of the design properties of the rear suspension. The rear suspension is much stiffer than the front suspension, because the tractor is designed to carry more weight on its rear axle than on its front axle. The more stiffly an axle is suspended, the greater the portion of vertical load it transfers from the inside tire to the outside tire when the vehicle is traversing a curve. When a much greater load transfer occurs at the rear axle than at the front axle, this results in a greater net loss in total side force at the rear tires than at the front tires. If the net loss at the rear axle is sufficient to destroy the fore-aft balance of tire side forces, yaw instability occurs; the front tires hold to the curved path and the rear tires move off the curved path to the outside.

The outward movement of the rear tires is not a "skid" such as results from insufficient tire/roadway friction. This instability can occur while the tires are operating well below the friction limit."

As the rear tires continue to move off the curved path, the yaw angle of the tractor will rapidly increase beyond the point of driver corrective capabilities and result in a jack-knife.

In the case of the dolly, the load is located ahead of the bogie so that it is evenly distributed on all three axles as shown in Figure 4. The suspension of each axle therefore has been designed with the same stiffness.

⁴ The highway tractor used in this test had a wheel base of 174 inches.

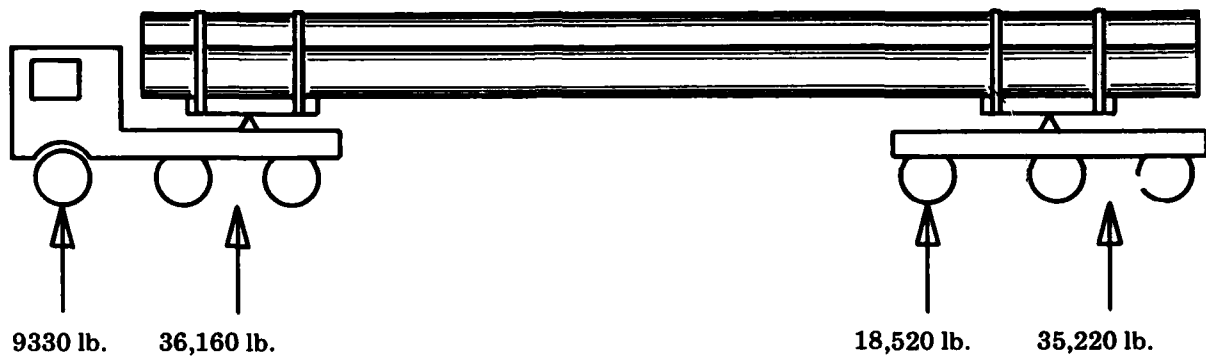

FIG. 4: LOAD DISTRIBUTION ON TRACTOR AND DOLLY

When the dolly encounters a curve, the load transfer to the outside tire of each axle will be approximately the same, thereby eliminating the net side force difference between all three axles which is responsible for the yaw instability leading to a jack-knife condition common to tractors.

If by some other means the dolly begins to skid, then, as the dolly rotates with respect to the load, the steering axle will respond in a direction approaching the line of travel, assuming that the tractor is under control. This should increase the likelihood of the steering wheels re-entering the friction or adhesion limit and pulling the dolly out of the skid. In addition, the dolly turntable has limit stops which restrict the rotation of the dolly with respect to the load to $\pm 23^\circ$ nominal.

3.0 TEST PROGRAM

The road tests were conducted from Feb. 11 to Feb. 16, 1981 along the Alaska Highway from Edmonton to Quill Creek in the Yukon near the Alaska border. To enable the acquisition of results consistent with the performance of the vehicle at normal operating speeds, the instrumentation and recording equipment on the vehicle were self-contained and were powered by a 3kw Honda auxiliary power unit saddled to the tractor frame. Mathematical relationships were developed which relate the measured quantities to off tracking and swept area of the vehicle. As a calibration check, the vehicle was taken slowly around two prescribed curves with a tangent lead in and run out. The off tracking of all axles was physically measured, as shown in Figures 5 and 6, and this was in turn related to the off tracking determined mathematically using the output from the instrumentation.

Because of the extreme length of the route, some 1500 miles, only selected portions of the route could be measured. Three of the most critical zones are a traffic circle in Dawson Creek (mile 0), a "switch back" curve at Steamboat and a series of "S" curves along Muncho Lake.

During the test procedure, video recordings were taken of the curves and of land marks to document the specific test regions. In addition, a running verbal commentary was simultaneously recorded on both voice tracks of the video and the Phillips F.M. recorder (used to record the transducer outputs). This enabled synchronization of the recorders during playback and served as descriptive background pertaining to the characteristics of the curve being negotiated. The mile posts passed along the route were used as reference points during recording.

3.1 Parameters Measured

The following is a list of the parameters measured during the test.

- 1) Tractor steering angle
- 2) Yaw angle of the pipe with respect to the tractor
- 3) Yaw angle of the dolly with respect to the pipe
- 4) The lateral acceleration of the dolly

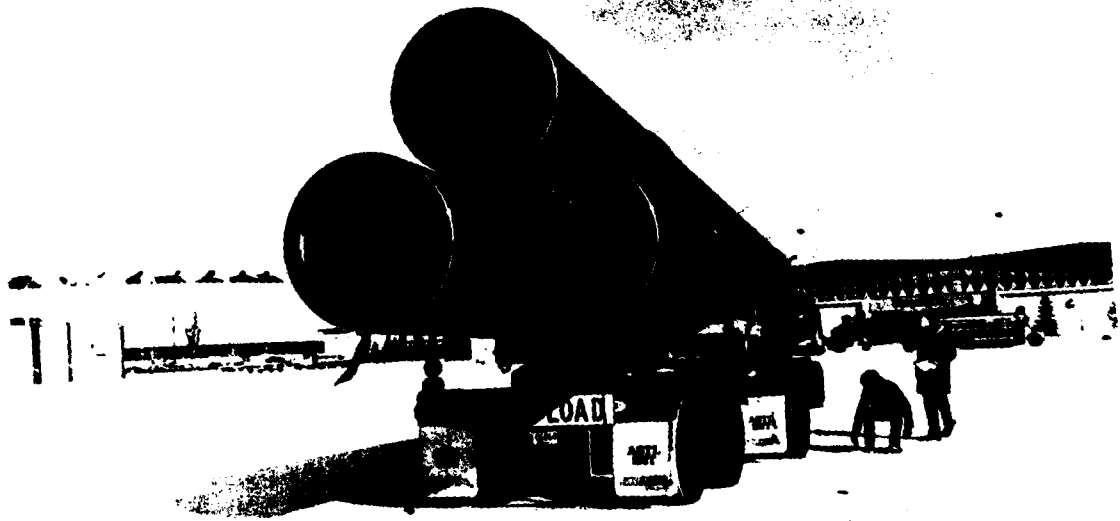
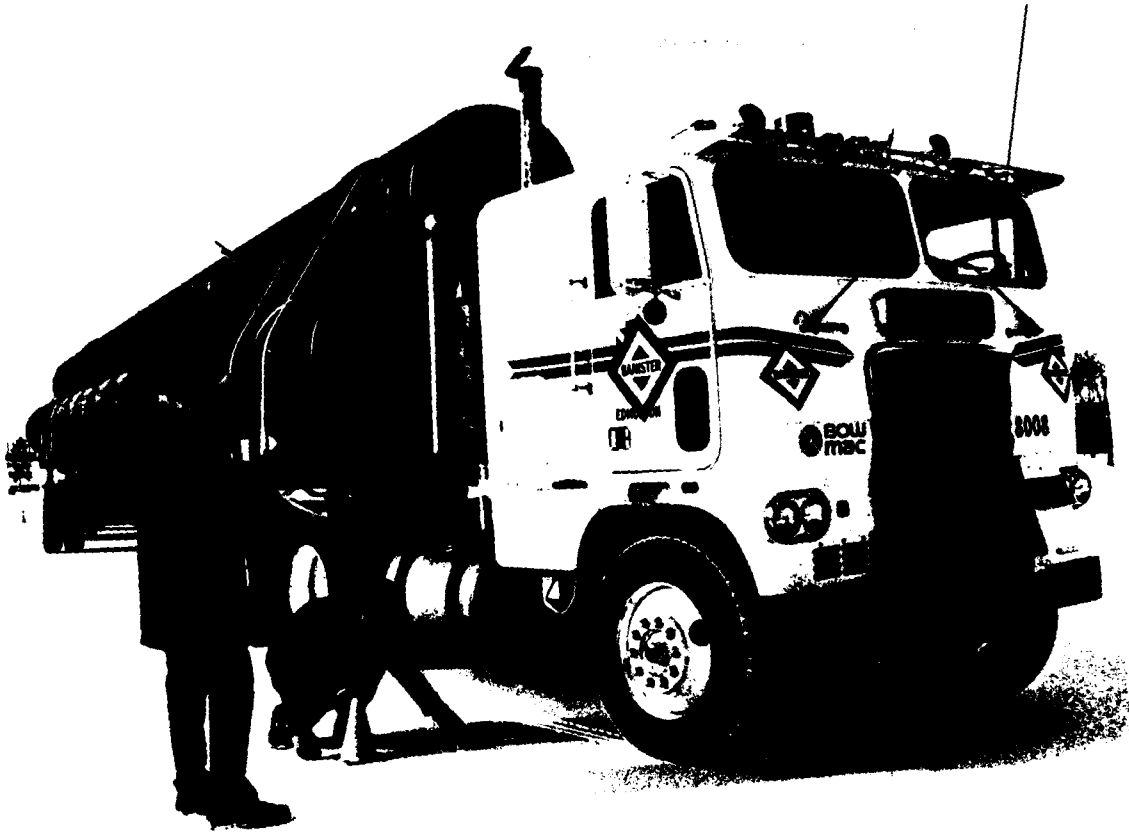

FIGS. 5, 6: PHYSICAL MEASUREMENT OF VEHICLE OFF TRACKING

- 5) The lateral acceleration of the tractor
- 6) Roll angle of the load
- 7) Pitch angle of the load
- 8) Vehicle displacement over time-base-velocity.

3.2 Instrumentation

The following instrumentation and recording equipment were used during the tests. A schematic diagram of the instrumentation layout is presented in Figure 7.

Equipment Mounted on the Vehicle

Quantity	Description
3	Bell & Howell Linear Accelerometers ± 15 g
2	Spectral Model 130 Single Turn Continuous Potentiometers
1	Bourns 10 Turn Potentiometer
1	Electro 3010-A Proximity Switch (velocity)
1	N.R.C.C. Roll Meter
1	Honda 115V 3 kw Generator

Equipment Located in the Cab

1	Brush Recorder #481 8 Channel
1	Phillips F.M. Tape Recorder EL 1020 7 Channel
1	Hewlett-Packard Frequency Counter, #5315A
1	Fluke Voltmeter #8600A
4	Vishay #2310 Signal Conditioning Units
1	Sony Oscilloscope
1	Sony Video Tape Recorder AV3600
1	Sony Video Camera AVC3260
1	Sony Monitor CMV115
2	Motorola Hand Held Radios

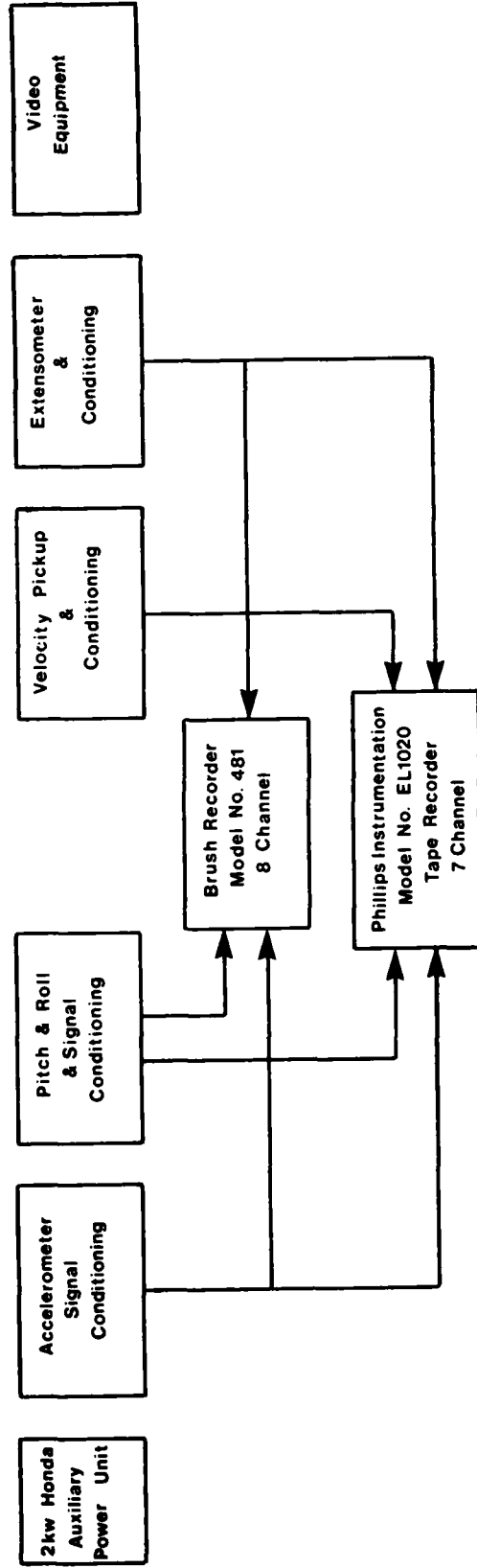
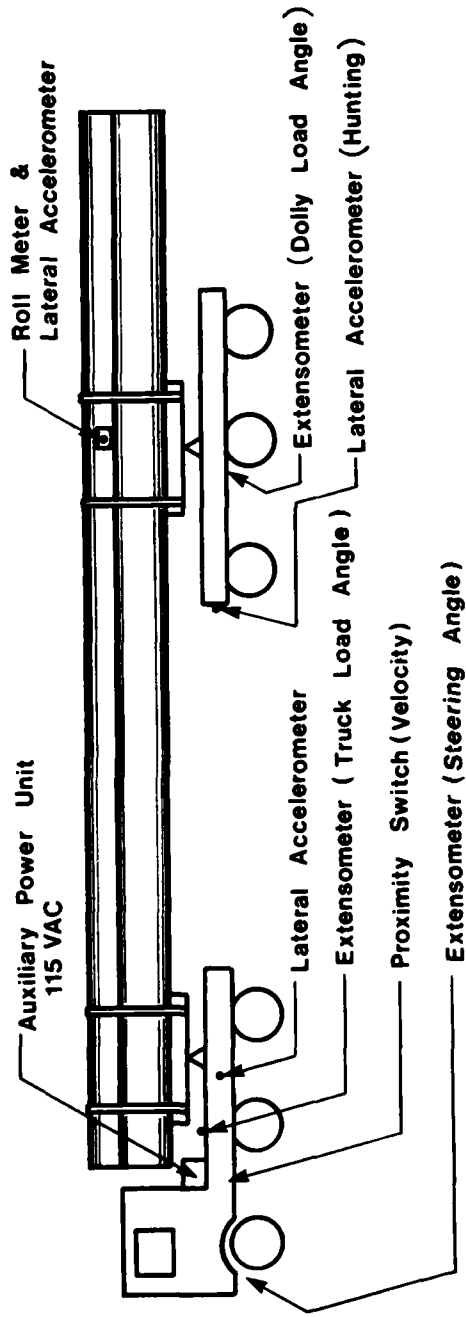

FIG. 7: SCHEMATIC OF INSTRUMENTATION LAYOUT

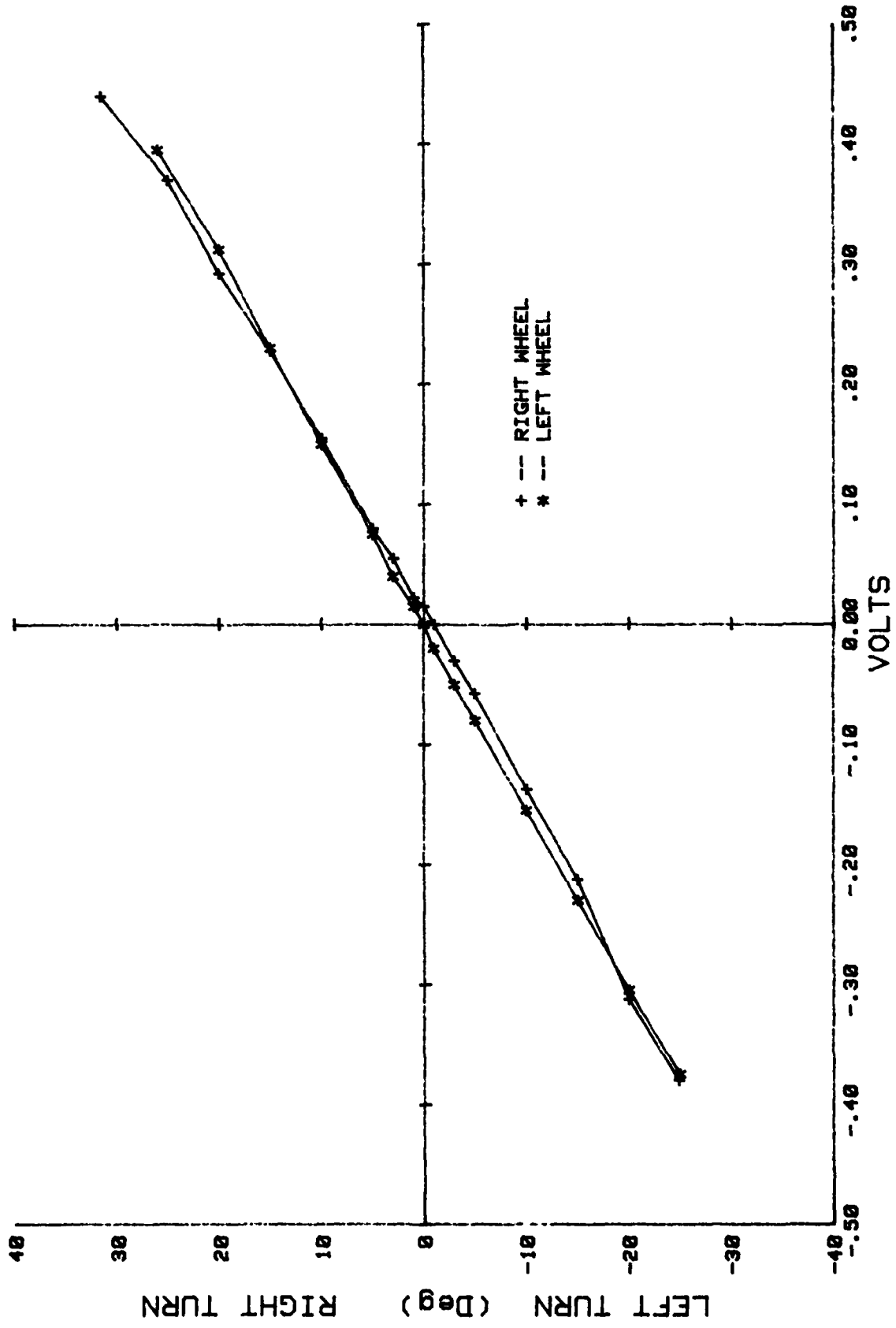

FIG. 8: TRACTOR STEERING CALIBRATION

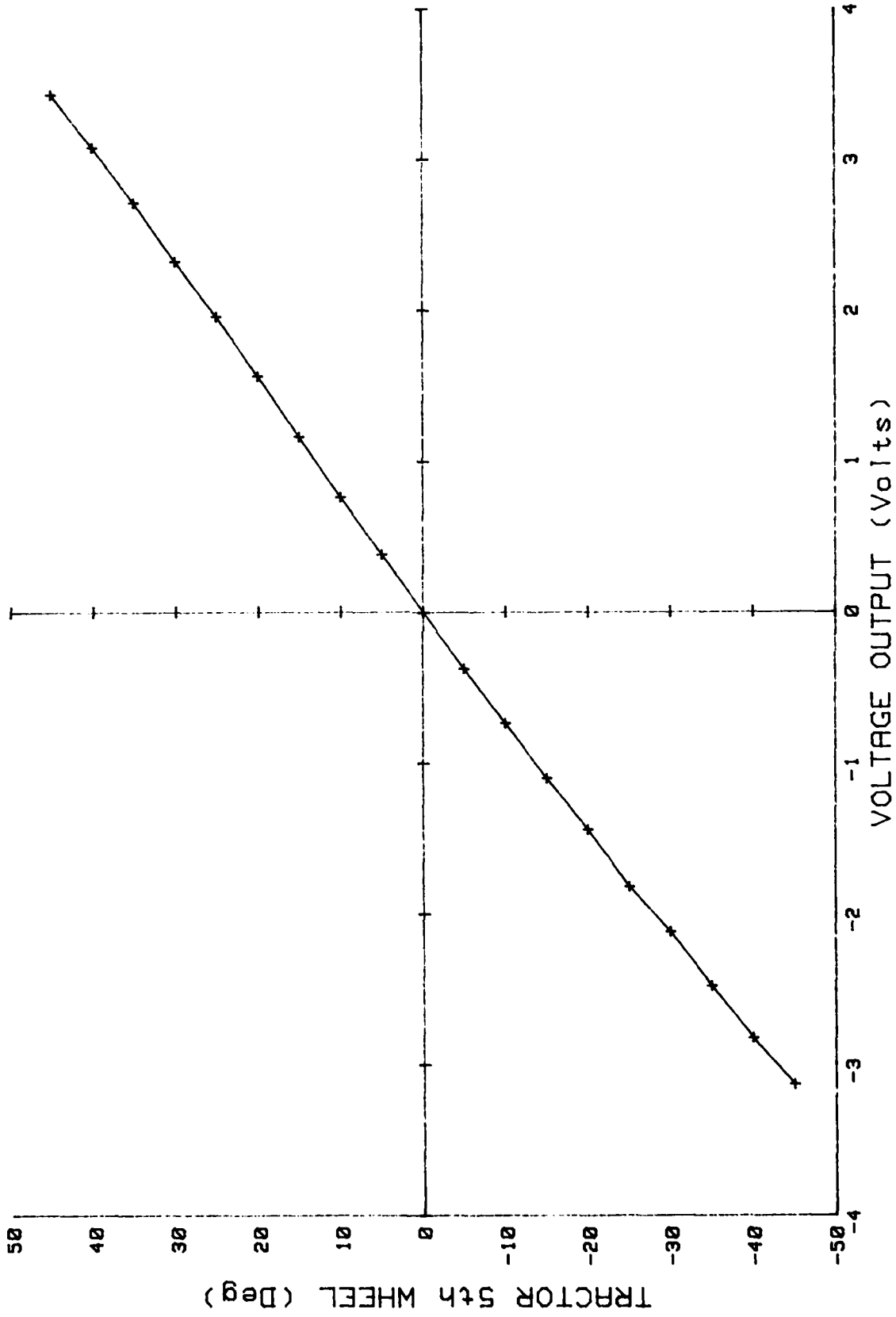

FIG. 9: TRACTOR FIFTH WHEEL CALIBRATION

3.3 Calibration of Transducers and Vehicle Components

3.3.1 Pitch and Roll Meter

The pitch and roll meter⁵ was calibrated using an indexing table in the lab prior to the test as it is a self-contained unit. The device consists of two viscous damped pendulums which pivot about two low friction potentiometers. The pendulum planes are at 90° to each other thereby sensing pitch and roll. An accelerometer was mounted on the meter to account for the lateral acceleration of curving which must be applied as a correction factor to obtain true roll.

3.3.2 Accelerometers

Physical calibration of the accelerometers were performed before and at the end of the test program. The calibration procedure involves inverting the accelerometers thus imposing a change in acceleration of 2g due to gravity.

3.3.3 Extensometers

Three extensometers were used during the tests. They were comprised of two continuous single turn 1k ohm potentiometers with 0.5% linearity and one 10 turn 10k ohm potentiometer having a linearity of 0.25%. An electrical input of ± 1 volt was used which resulted in a full scale potential change of 2 volts. The potentiometers were fitted with pulleys of known circumference over which travelled a light wire connected to the moving member being measured.

The calibration procedure for the three extensometers follows.

3.3.4 Tractor Steering

With the front axle of the tractor jacked, straight edges were clamped to the two wheels so that the angle of the wheels could be measured. An arc, pivoted about the king pin of each wheel was scribed on the floor and then marked off in degrees. As the steering wheel was turned, the wheels and hence the straight edges swept the arc. The change in the voltage of the extensometer as a function of angular displacement was recorded and plotted as shown in Figure 8.

3.3.5 Tractor Fifth Wheel

The bunk used to support the pipe rested on and pivoted about the fifth wheel. An extensometer was fixed to the truck frame and the extension wire fastened to the bunk. The bunk was rotated by hand and its angular displacement was determined using the same technique as for the tractor steering calibration. Again the voltage as a function of angular displacement was recorded and plotted, see Figure 9.

3.3.6 Dolly Turntable

The third extensometer was fixed between the turntable and the dolly frame. The steering axle was jacked and straight edges were clamped to the wheels. Again arcs were scribed on the floor. A straight edge was also fixed to the turntable and was referenced to a third arc also measured off in degrees of rotation. As the turntable was incrementally rotated, the resulting change in steering angle and the electrical voltage was recorded and subsequently plotted. This resulted in a turntable to steering calibration, Figure 10, and a turntable angle to voltage change relationship. See Figure 11.

⁵ The unit was designed by Mr. E. Bowler and Mr. A. Forward of NRC's Railway Lab to measure the pitch and roll of west coast barges.

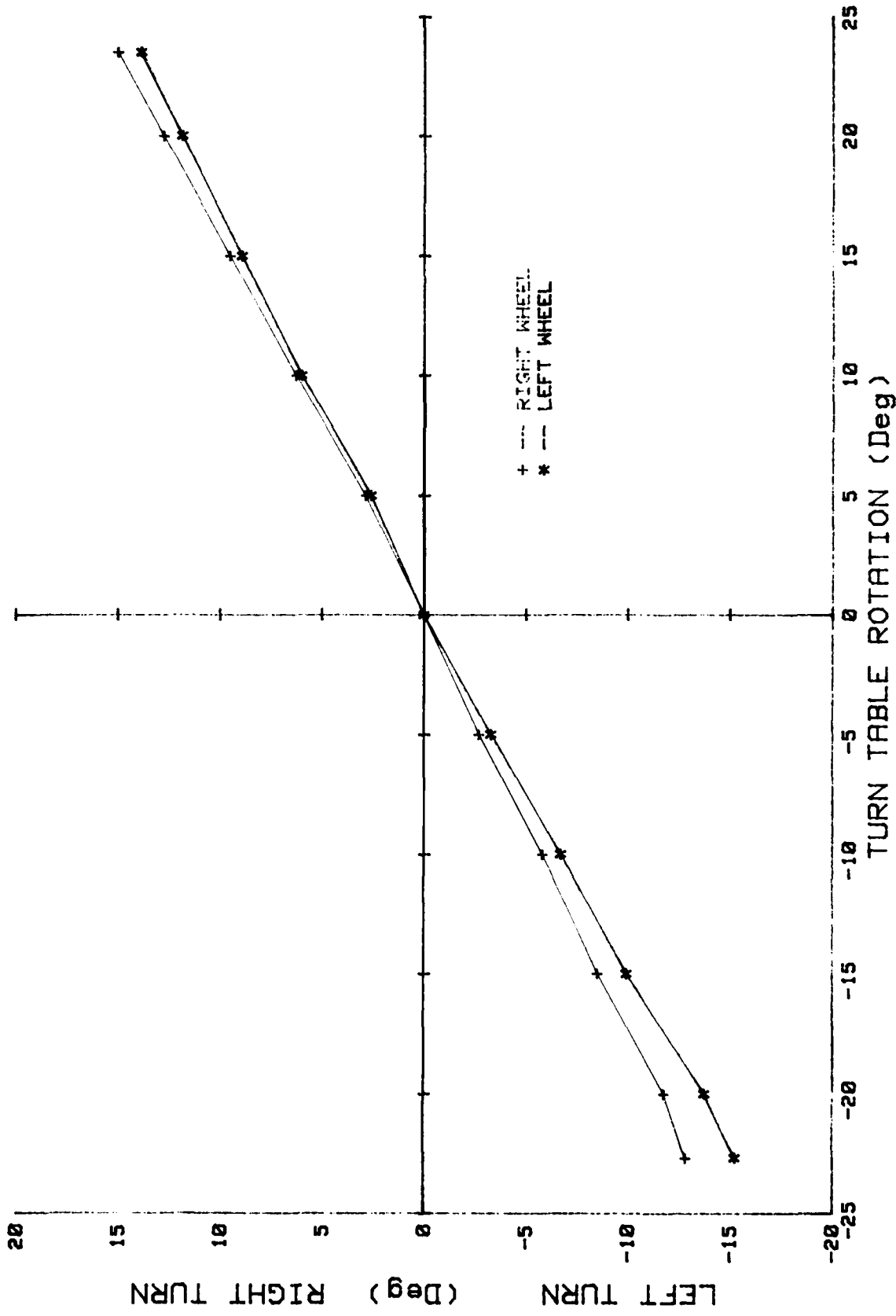

FIG. 10: DOLLY TURNABLE TO STEERING ANGLE CALIBRATION

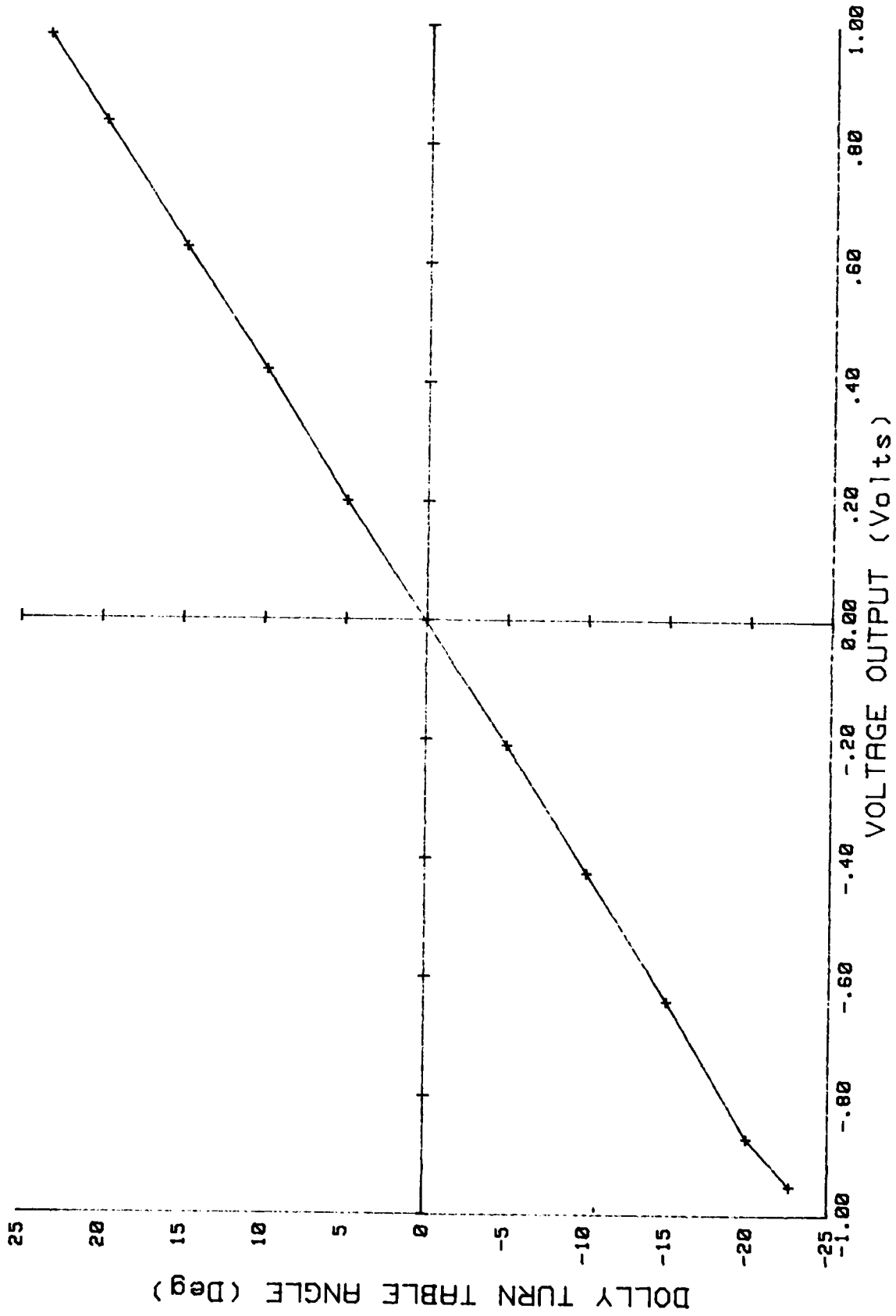

FIG. 11: DOLLY TURNTABLE ANGLE TO VOLTAGE CALIBRATION

3.3.7 Vehicle Displacement Transducer

The vehicle displacement transducer consisted of a proximity switch mounted very near to the drive shaft onto which were welded four steel lugs at 90° intervals. Hence, for each rotation of the drive shaft the proximity switch produced four electrical pulses. The pulses were recorded on the same magnetic tape as the other transducer outputs and were also fed into a frequency counter having an accumulated pulse count mode. This gave a record of velocity and displacement of the vehicle at any point. The displacement transducer was calibrated by dividing the number of pulses by a known distance travelled. This resulted in a calibration of 1.49 pulses per linear foot.

4.0 DEVELOPMENT OF THE KINEMATIC MATHEMATIC EXPRESSIONS

From the first principles of vehicle curving, it can be shown that in a steady state condition, all wheels must theoretically track tangent to their curve radii as shown in simplified form in Figure 12.

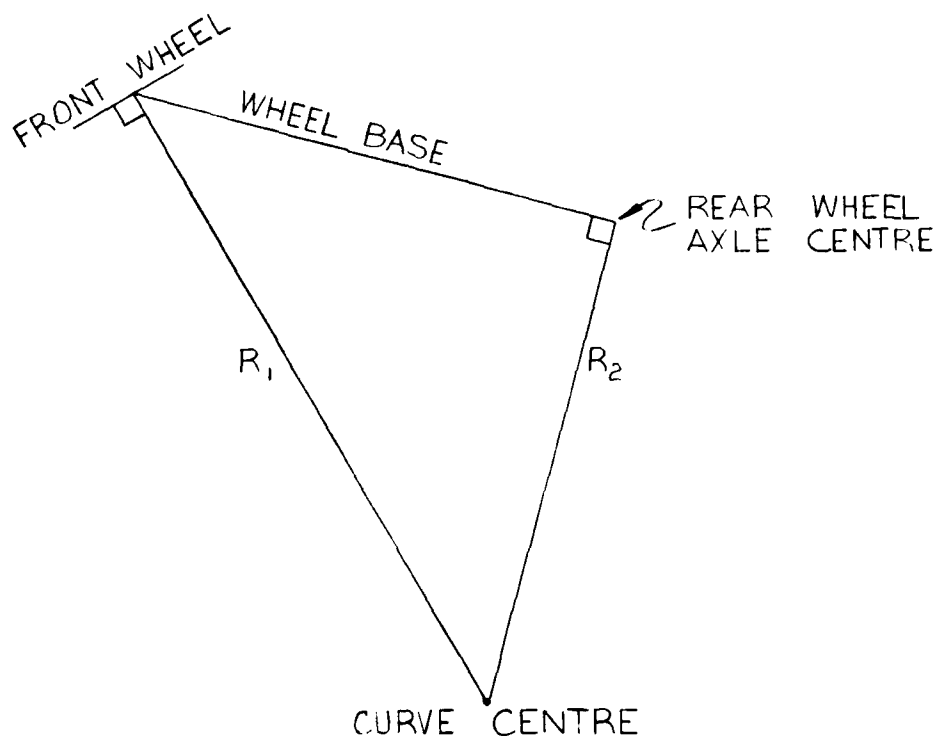

FIG. 12: KINEMATIC CURVING DIAGRAM OF A BICYCLE

In the case of a multi-wheeled and axled vehicle, such as a tractor with a tandem axle, where the tandem axles are constrained to parallelism, the curving principle still holds except that the bogie centre of the tandem axle is taken to be the location of the tangent to the curve.

This may introduce some error as it is highly unlikely that the curving tangent would occur precisely midway between the tandem axles. In past studies, it has been found that the tangent is usually located some distance aft of the bogie centre (Ref. 2). In practical terms, however, the magnitude of this potential error should be small.

To simplify the mathematics, the curve radii will be measured to the centreline of the vehicle. Therefore, the theoretical vehicle will not have any dimensional width except when load excursion limits and swept area calculations are conducted.

The illustrations used for the mathematical derivations which follow will depict the vehicle plan view as a single line rather than the conventional two-dimensional drawing.

4.1 Steady State Kinematic Curving Analysis

A) Tractor

See Figure 13.

In the curving analysis of the tractor, the mathematics are based upon the solution of a simple right angle triangle.

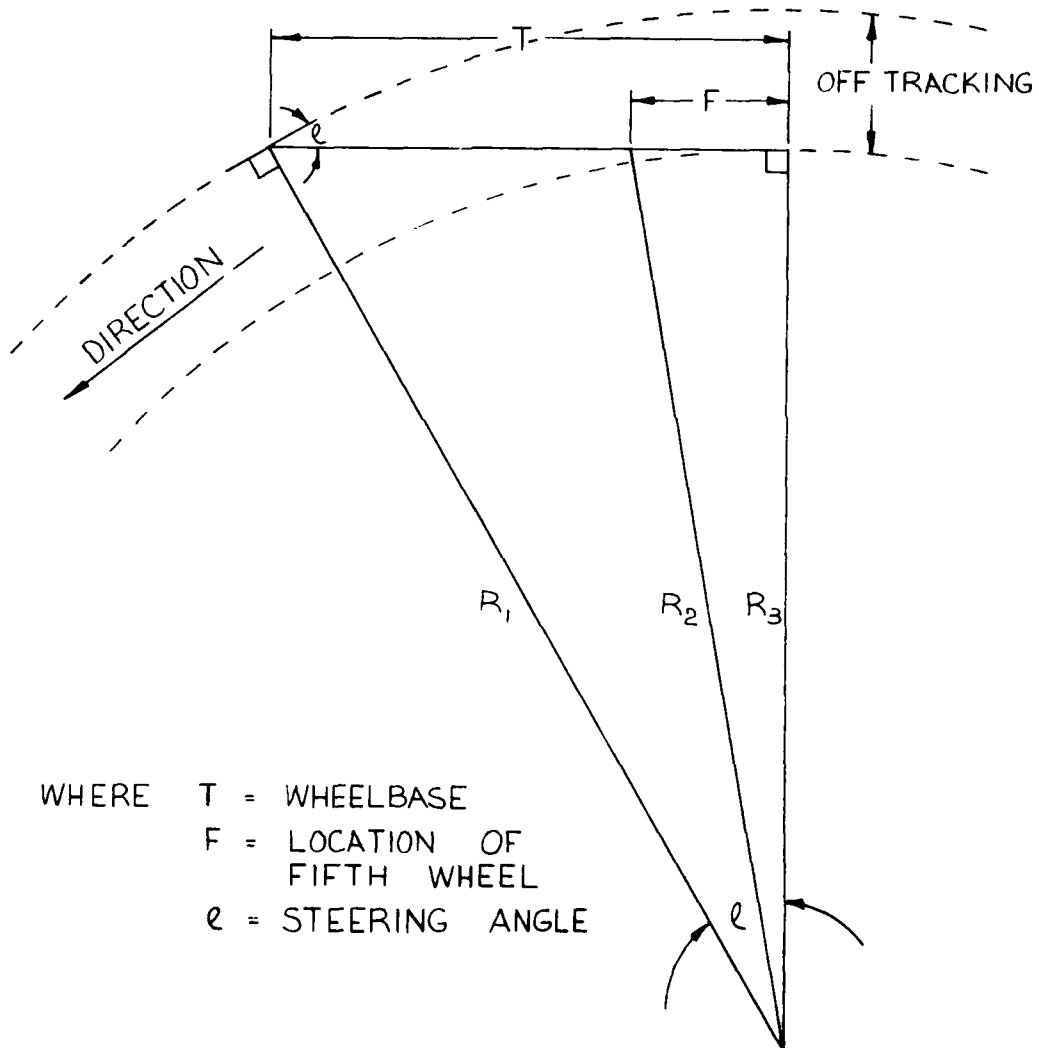

WHERE T = WHEELBASE
 F = LOCATION OF FIFTH WHEEL
 ρ = STEERING ANGLE

FIG. 13: KINEMATIC CURVING DIAGRAM OF A TRACTOR

For a steering angle of ρ .

$$R_1 = \frac{T}{\sin \rho}$$

$$R_3 = (R_1^2 - T^2)^{1/2}$$

$$R_2 = (F^2 + R_3^2)^{1/2}$$

B) Dolly with load.

The geometrical analysis of the dolly is somewhat more complex than that of the tractor. Since, through mechanical linkage, the dolly steering angle is directly related to the angle of the load with respect to the dolly at any instant, the orientation of the load enters into the solution, as shown in Figure 14.

The solution of R_6 , R_5 and R_4 are again based upon the right angle triangle.

$$R_6 = \frac{D}{\text{TAN}(\text{Sr } \theta)}$$

$$R_5 = (P^2 + R_6^2)^{1/2}$$

$$R_4 = \frac{D}{\text{Sin}(\text{Sr } \theta)}$$

where Sr = steering ratio

Having solved for R_5 and R_6 , α and ϕ become

$$\alpha = \text{TAN}^{-1} \frac{R_6}{P}$$

$$\phi = 180 - \theta - \alpha$$

$$= 180 - \theta - \text{TAN}^{-1} \frac{R_6}{P}$$

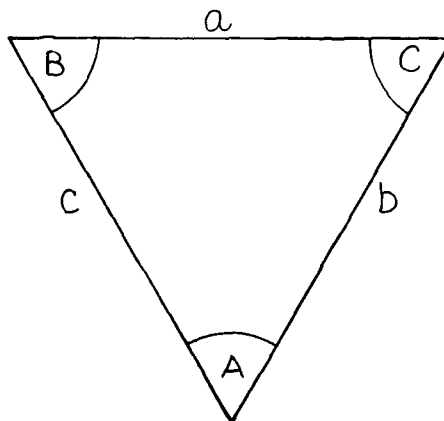

FIG. 15: ILLUSTRATION FOR TRIGONOMETRIC SOLUTION

Using the trigonometric relationship, which follows,

$$c = (a^2 + b^2 - (2ab \text{Cos } C))^{1/2}$$

the solution of R_2 becomes

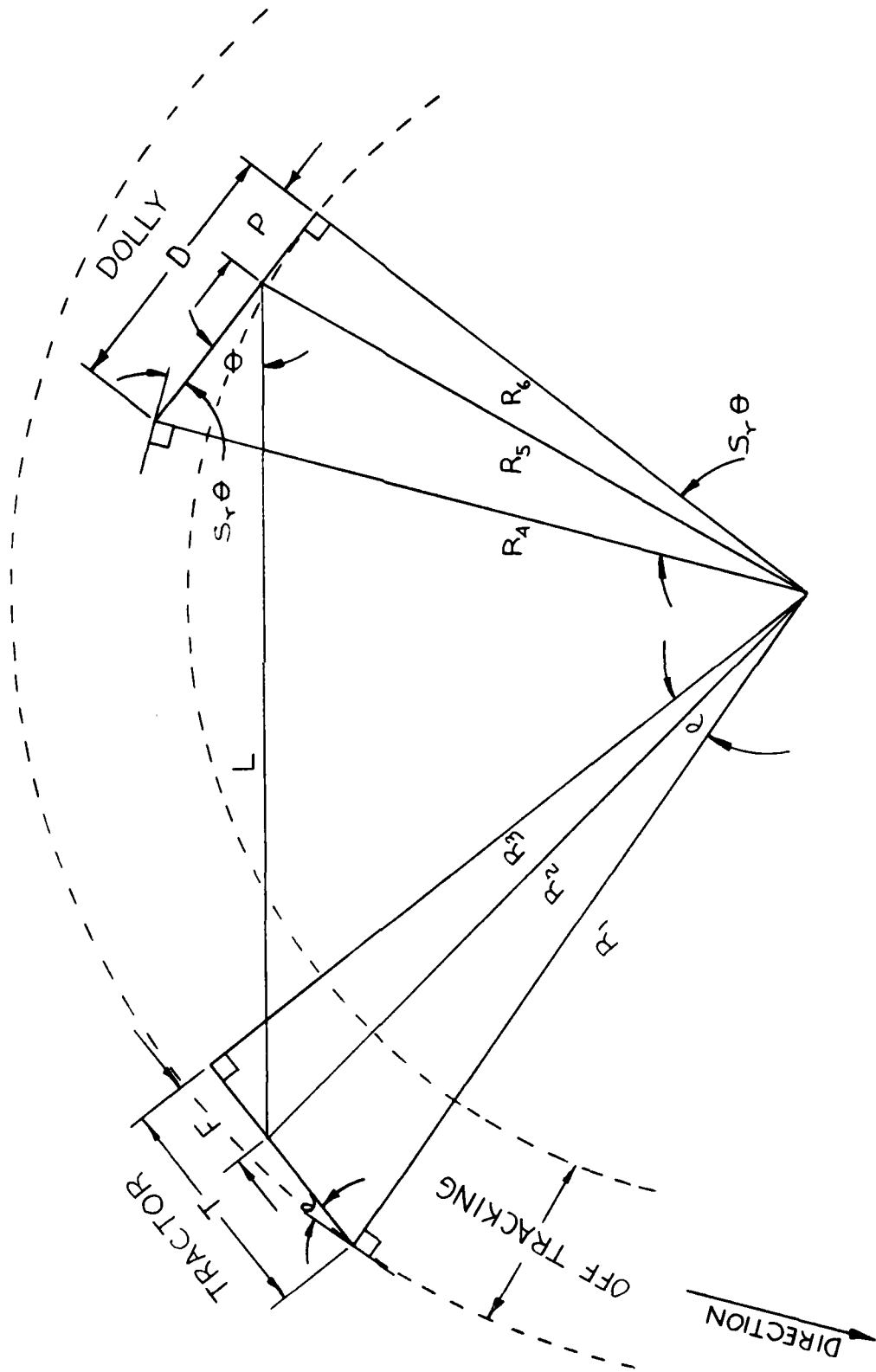

FIG. 16: COMBINED GRAPHICAL SOLUTION OF VEHICLE IN STEADY STATE CURVING

$$R_2 = (L^2 + R_5^2 - (2 L R_5 \cos \phi))^{1/2}$$

or in the most general terms

$$R_2 = \left(L^2 + P^2 + R_6^2 - \left(2L(P^2 + R_6^2)^{1/2} \cos \left(180 - \theta - \text{TAN}^{-1} \frac{R_6}{P} \right) \right) \right)^{1/2}$$

Combining the graphical solution for the tractor with that of the dolly, assuming they are turning about the same point, as shown in Figure 16, one can now calculate the off tracking of the tractor's leading axle with that of the dolly's bogie centre $R_1 - R_6$.

where
$$R_1 = (R_2^2 + (T-F)^2)^{1/2}$$

From Figure 17 it is clear that the tractor's curving geometry is independent of the dolly for non-steady state curving.

The fifth wheel of the tractor is, however, related to both the instant curve centre of the tractor and the instant curve centre of the dolly as shown in Figure 17. Since the load length is long in relation to the tractor wheel base, if one knows R_2 and R_6 , i.e. the curving solution of the dolly, then an estimation of R_1 based upon steady state curving, will give a good approximation as to the total vehicle off track of $R_1 - R_6$ for non-steady state curving.

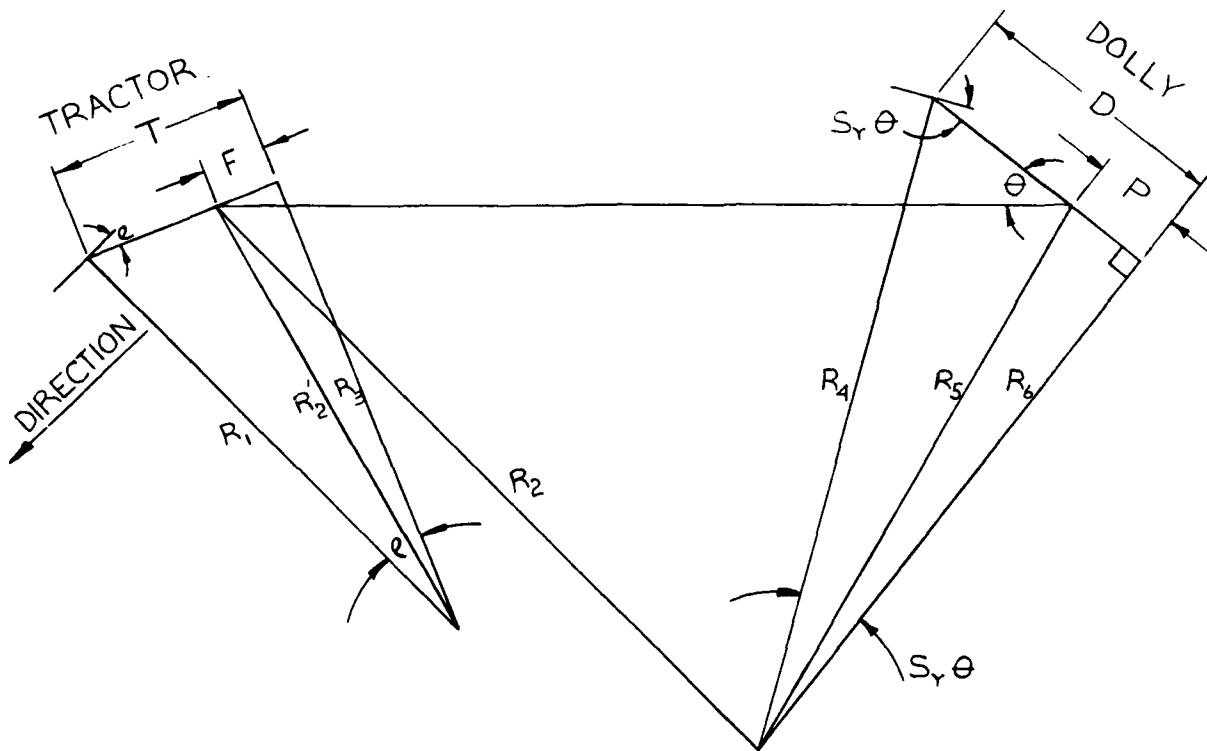

FIG. 17: COMBINED GRAPHICAL SOLUTION OF VEHICLE DURING NON-STEADY STATE CURVING

5.0 CALIBRATION RUN

A calibration run was conducted at Edmonton's Northlands Park, whereby the vehicle negotiated two 90° curves of radii 100 and 200 ft. with 100 ft. tangent lead ins and run outs. For each of the two radii, the vehicle negotiated two passes, resulting in one right and one left turn per radius.

The off tracking and curve radius at each axle was measured at intervals shown in Figure 18.

The data collected were used as a reference to check the analogue outputs which formed the inputs for the analytical expressions developed to determine the curving radii and subsequent vehicle off tracking. The road condition for the calibration was snow covered ice.

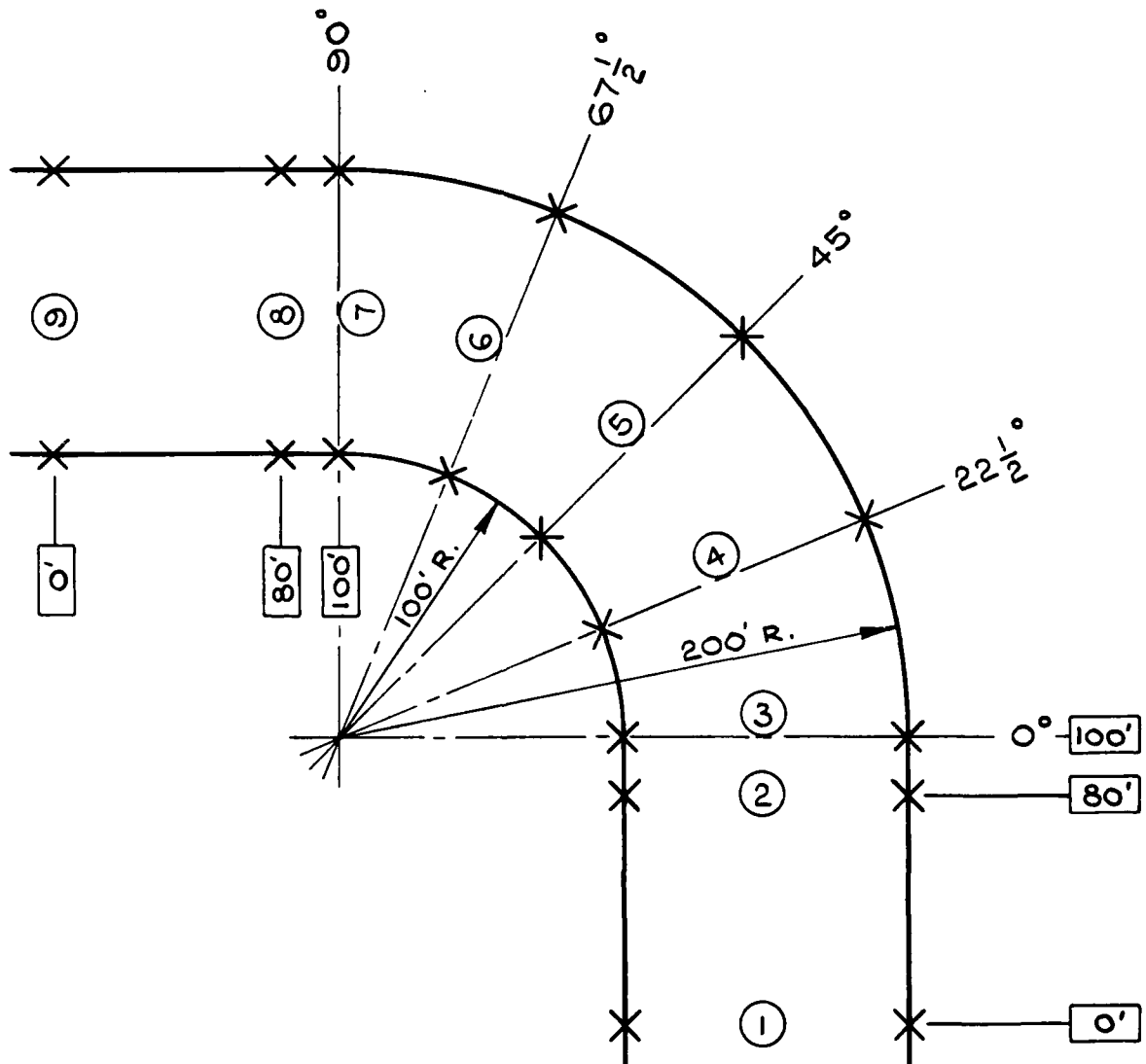

FIG. 18: ILLUSTRATION OF THE CALIBRATION CURVE
Each X represents a point where physical measurements were taken.

5.1 Calibration Run Results

As discussed earlier in Section 4.1, the tractor's fifth wheel is related to both the instant centre of the tractor and the instant centre of the dolly. The mathematical analysis defines the radius scribed by the tractor's fifth wheel and by the dolly's bogie centre with respect to the dolly's instant centre. For this reason, the off tracking used for the data comparison will be the radius scribed by the tractor's fifth wheel minus the radius scribed by the bogie centre of the dolly, i.e. $R_2 - R_6$.

Table 1, following, lists the peak curving data as measured at the Northlands Park test site. (Complete off tracking data is presented in Appendix A).

TABLE 1
DATA AS MEASURED BY HAND (ACTUAL)

Nominal Curve Radius (Ft)	Radius of Curvature at Vehicle Centre (Ft)					Off Tracking (Ft)	
	R ₁	R ₂	R ₃	R ₄	R ₆	R ₂ - R ₆	R ₁ - R ₆
100 Left	92.5	91.8	91.8	88.6	87.5	4.3	5.0
100 Right	94.4	93.8	93.8	90.0	88.9	4.9	5.5
200 Left	192.9	192.6	192.6	191.9	191.2	1.4	1.7
200 Right	193.7	193.6	193.6	92.4	191.9	1.7	1.8

Note: R₁, R₃, R₄, R₆ represent radii of curves scribed by the axles or bogie centres of the vehicle from front to rear.

- R₁ Tractor Steering Axle
- R₂ Tractor Fifth Wheel
- R₃ Centre of the Tractor Tandem Axles
- R₄ Dolly Steering Axle
- R₆ Centre of the Dolly Tandem Axles.

The load/dolly angle data generated from the analogue signal recorded during the tests were digitized and used as input to the mathematical relationship described in Section 4.1. The results from the equations were compared to the measured data listed in Table 2 and are presented in graphical form in Figures 19 and 20.

These graphs show a comparison of calculated and measured off tracking of the vehicle from the centre of the dolly tandem axle to the centre of the tractor tandem axle.

The vertical axis is self-explanatory; however, the horizontal axis is a linear representation of the calibration curve shown in Figure 18. From 0 to 100 feet represents the tangent lead in, 100 to 250 or 410 ft. nominal, (100 and 200 ft. radius curves respectively) represents the 90° curve and the remainder is the 100 or more foot run out tangent.

The graphs show the measured off tracking to be consistently better than the calculated off tracking. Table 2 lists the mean peak off tracking and the radius of curvature at R₂ and R₆ for both measured and calculated values.

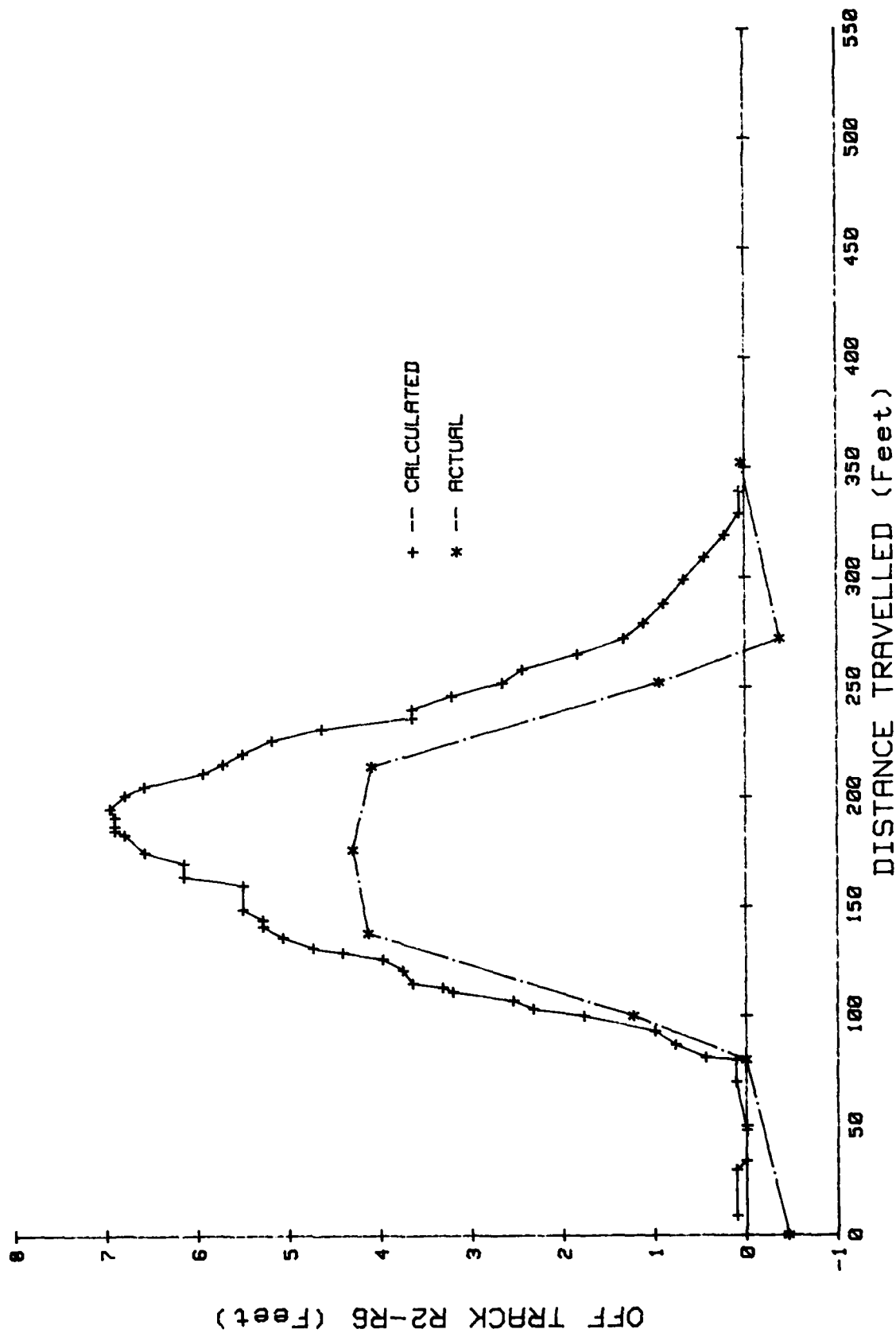

FIG. 19: ACTUAL AND CALCULATED OFF TRACKING 100 FT. LEFT CURVE

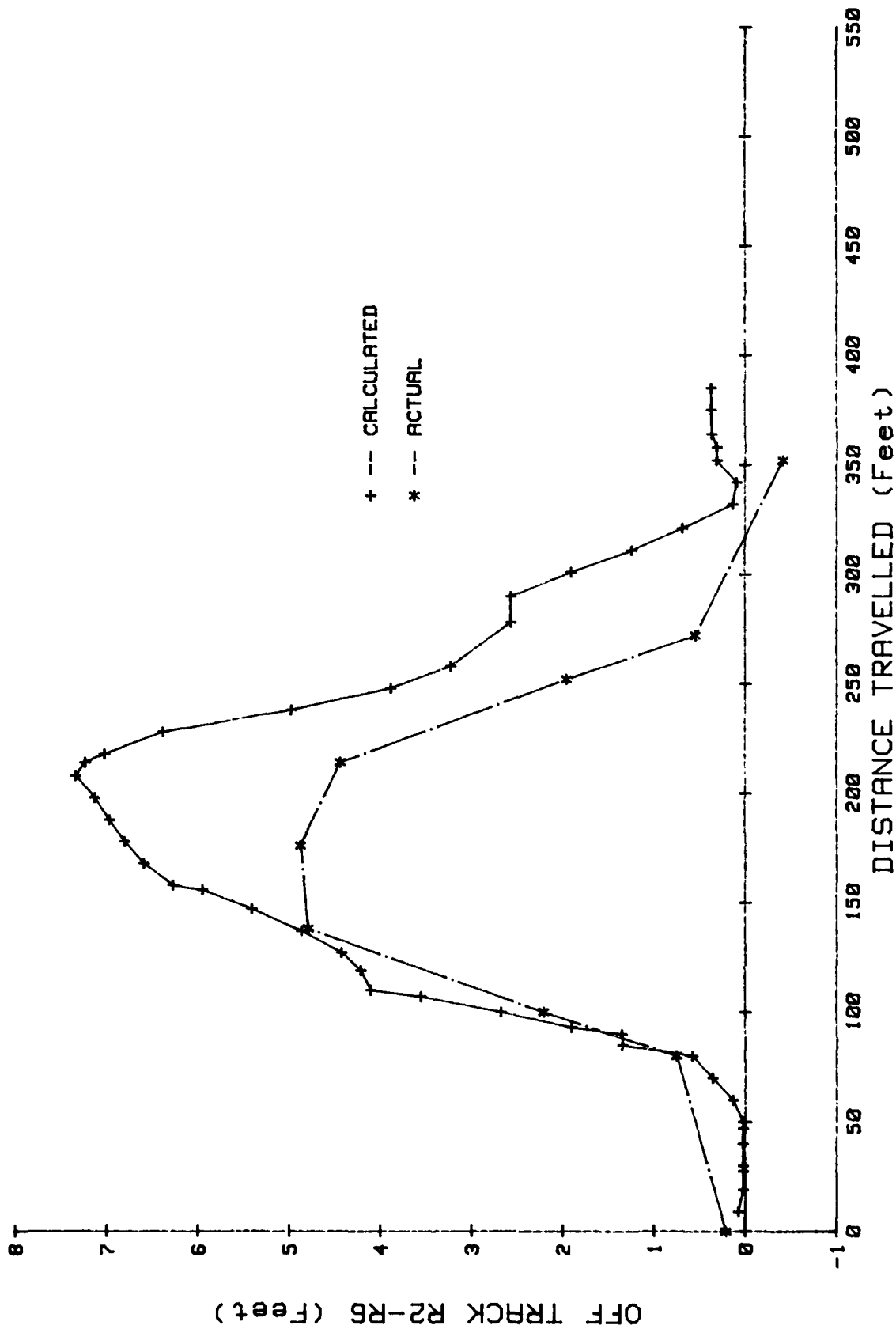

FIG. 19A: ACTUAL AND CALCULATED OFF TRACKING 100 FT. RIGHT CURVE

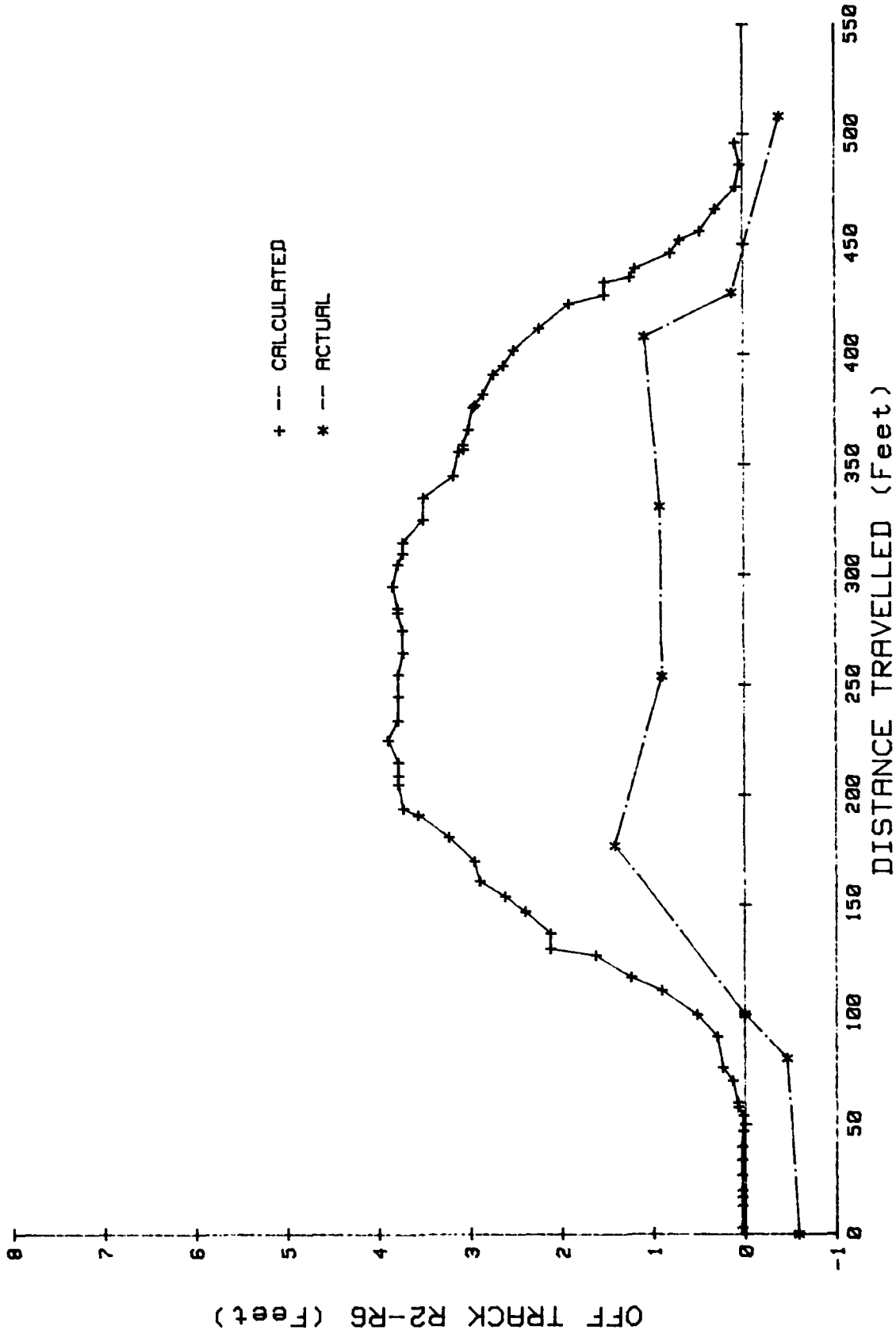

FIG. 20: ACTUAL AND CALCULATED OFF TRACKING 200 FT. LEFT CURVE

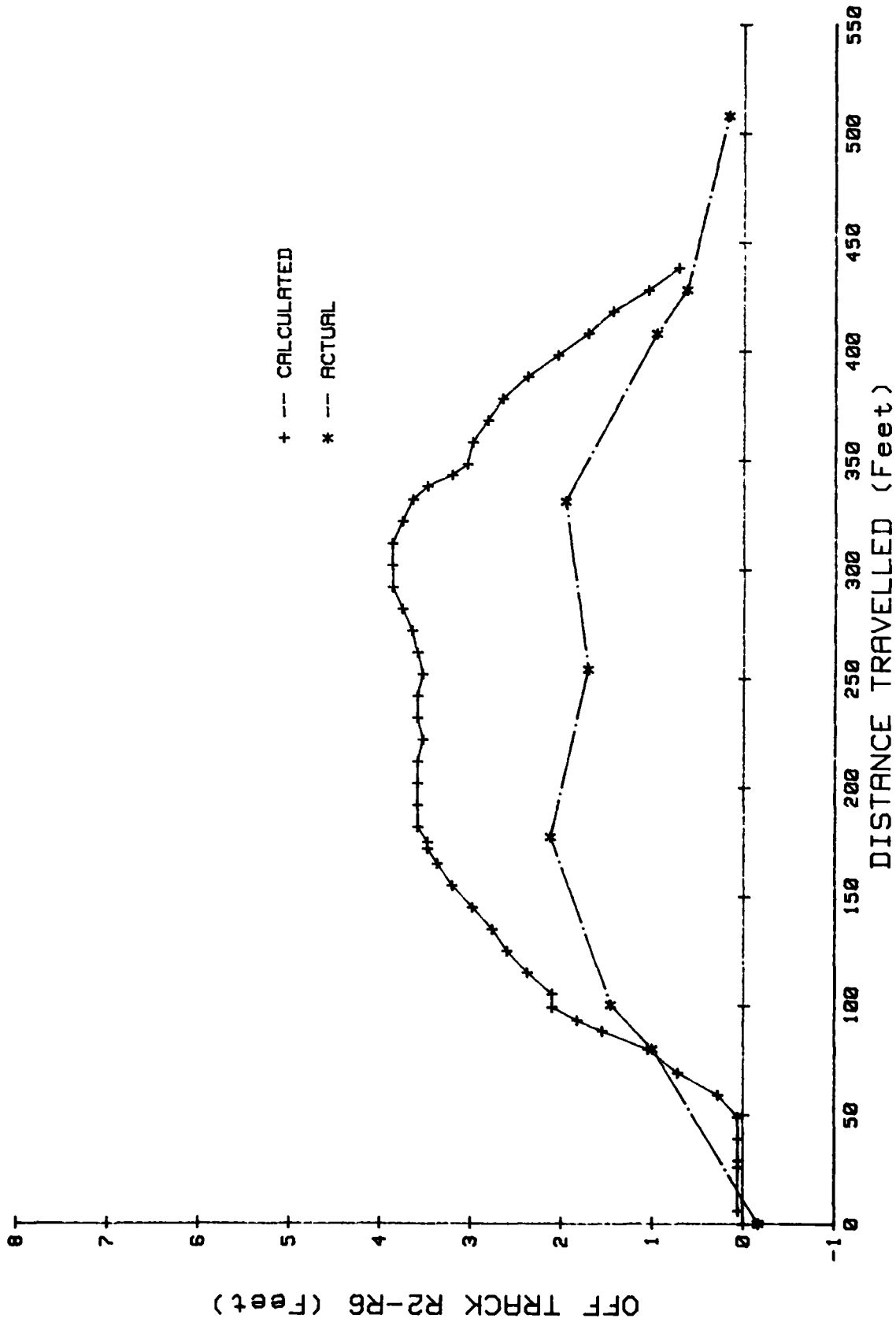

FIG. 20A: ACTUAL AND CALCULATED OFF TRACKING 200 FT. RIGHT CURVE

TABLE 2

MEASURED AND CALCULATED NEAR PEAK VALUES OF OFF TRACKING
AND THE RADII SCRIBED

Nominal Curve Radius (Ft)	Actual (Ft)			Calculated (Ft)			
	R ₂	R ₆	R ₂ - R ₆	θ Deg	R ₂	R ₆	R ₂ - R ₆
100 Left	91.8	87.5	4.3	14.95	92.2	85.3	6.9
100 Right	93.8	88.9	4.9	15.96	89.0	81.9	7.1
200 Left	192.6	191.2	1.4	8.12	161.8	158.1	3.7
200 Right	193.6	191.5	2.1	8.31	158.3	154.4	3.9

Table 3 expresses the differences between the measured and calculated mean peak off tracking and radii of curvature based upon the actual values.

TABLE 3

DIFFERENCES BETWEEN CALCULATED AND ACTUAL OFF TRACKING
AND CURVE RADII

Nominal Curve Radius (Ft)	ΔR ₂ (Ft)	ΔR ₆ (Ft)	Δ(R ₂ - R ₆) (Ft)	ΔR ₂ %	ΔR ₆ %	Δ(R ₂ - R ₆)%
100 Left	+0.4	-2.2	+2.6	+0.4	-2.5	+60.5
100 Right	-4.8	-7.0	+2.2	-5.1	-7.9	+44.9
200 Left	-30.8	-33.1	+2.3	-16.0	-17.3	+164.0
200 Right	-35.3	-37.1	+1.8	-18.2	-19.4	+85.7

From Tables 2 and 3 it is clear that the calculated radii of curvature of the 100 ft. curve are very close but the off tracking shows a large disagreement. The 200 ft. curve shows more radius error but in proportion to the off tracking error it is not much worse than the 100 ft. curve.

Table 4 shows a comparison between actual radius of curvature and off tracking with strict theoretical steady state off tracking.

TABLE 4

COMPARISON BETWEEN ACTUAL AND THEORETICAL STEADY STATE CURVING

Nominal Curve Radius (Ft)	Actual (Ft)			Theoretical (Ft)			$\Delta(R_2 - R_6)\%$ Based upon Actual Values
	R_2	R_6	$R_2 - R_6$	R_2	R_6^*	$R_2 - R_6$	
100 Left	91.8	87.5	4.3	94.2	87.5	6.7	55.8
100 Right	93.8	88.9	4.9	95.5	88.9	6.6	34.7
200 Left	192.6	191.2	1.4	194.4	191.2	3.2	129.0
200 Right	193.6	191.5	2.1	194.9	191.5	3.4	61.9

* R_6 from the measured data was used as the input to calculate the theoretical data.

The measured off tracking is again consistently better than the theoretical values. There is also a significant difference between the off track error during left and right curves. This is the result of the known misalignment of the dolly to be explained further in Section 6.4. When the measured left and right off track values are averaged and then compared to the theoretical values; the discrepancy becomes 45% for the 100 ft. curve and 88.6% for the 200 ft. curve. The fact that the percentage off track error is very much greater for the 200 ft. curve is somewhat misleading. It is important to note that this only represents an error of 1.55 ft.

It is not clear why the dolly consistently tracks better than theoretically predicted. One initially attractive reason may be that the 90° curve negotiated did not allow the vehicle to approach or reach a steady state condition. If this were so, however, one would expect the 200 ft. off track results to be closer to the theoretical values than the 100 ft. curve results because the distance available to stabilize around the 200 ft. curve is twice as long as the 100 ft. curve.

The graphics in Figures 19 and 20 show a flattening of the 200 ft. off tracking curve which seems to indicate that the dolly started to approach a steady state curving condition.

It is quite likely that the discrepancy in off tracking is due to the dynamics of vehicle curving which are unique to this vehicle. Two possible explanations follow.

When negotiating a curve, a road vehicle both translates and rotates. It is the rotation of the pipe with respect to the dolly which results in a change of the dolly steering angle. But for the dolly to change its direction, it must translate and the speed with which it translates dictates how rapidly it can react to the angular change of the pipe.

The tighter the curve, the less the pipe translates per unit of rotation and as a consequence, the less the dolly can rotate in reaction to the curve. This therefore results in the dolly tracking more towards the outside of the curve thereby improving the overall vehicle off tracking characteristics.

The second influence maybe the lateral creep of the steering tires of the dolly. The lateral creep results from the tire side force that the road surface exerts on the tire in a direction perpendicular to the plane of the wheel.

In the ideal curving situation as explained in Section 4.1, the wheels of the steering axle will be aligned precisely so that the plane of the wheels is perpendicular to a radial projection from the curve centre. In reality, however, the wheels of the steering axle must generate a moment from the tire side forces of sufficient magnitude to overcome the propensity for the bogies to continue on a straight line. This side force, in conjunction with the rolling of the tires, results in lateral creeping of the wheels of the steering axle to the outside of the curve. This has the effect of increasing the radius of curvature scribed by the dolly and ultimately reducing the off tracking of the vehicle.

6.0 HIGHWAY TEST RESULTS

The road conditions encountered along the Alaska Highway were varied, ranging from centre bare, to snow packed, to glare ice. Much of the Alaska Highway through British Columbia is narrow with an abundance of curves. The average road width is roughly 20 ft. but in sharp curves it widens to approximately 30 ft.

As the road winds its way around mountains and hills, many dangerous curves are encountered. However, once past the Yukon border, the roadway is much improved due to considerable road reconstruction.

Not surprisingly, the two sharpest curves were encountered in B.C. at the Dawson Creek traffic circle and a switch back curve at Steamboat. A third stretch along Muncho Lake has a great many curves but they are short in duration and not as tight as the two previously mentioned. Consequently, Muncho Lake will not receive further discussion.

6.1 Dawson Creek Traffic Circle

A scale drawing of the Dawson Creek traffic circle is presented in Figure 21. It has an inner radius of 63 ft. and an outer radius of 90 ft. giving a roadway width around the circle of 27 ft.

The circle's incoming and outgoing roadways only differ in direction by 25°, however, it can be seen from Figure 21, that because of the entrance points to the circle, a vehicle must scribe a constant radius arc of approximately 180°. In addition, there is a short lead in curve of opposite direction to the major circle curve which will benefit long wheelbase vehicles as it tends to initially offset the trailer to the outside of the major curve.

From the data collected, it was learned that the dolly reached its maximum angular limit of 23° and remained at this limit for approximately 170 ft. while negotiating the traffic circle. This, however, was not apparent within the vehicle as there was no perceptible change in the behaviour of the vehicle.

In addition, the tractor steering angle extensometer used to measure the steering angle of the tractor malfunctioned, leaving only the fifth wheel extensometer signal as a data source.

By assuming the mean curve radius to be 76.5 ft., and knowing that the maximum fifth wheel rotation was 24.3°, the maximum off tracking, 4.5 ft., was determined graphically as illustrated in Figure 22. This technique was also used to determine the swept area which was estimated to be 18.2 ft. To provide the validity of this approach, similar graphical solutions were constructed for the 100 ft. calibration curves which are presented in Table 5.

TABLE 5
COMPARISON OF ACTUAL OFF TRACKING RESULTS WITH THOSE DETERMINED
GRAPHICALLY FROM THE 100 FT. CALIBRATION TESTS

Nominal Curve Radius (Ft)	Off Tracking ($R_1 - R_6$) (Ft)	
	Actual	Graphical Using Fifth Wheel Angle
100 Left	5.0'	4.25'
100 Right	5.5'	5.65'

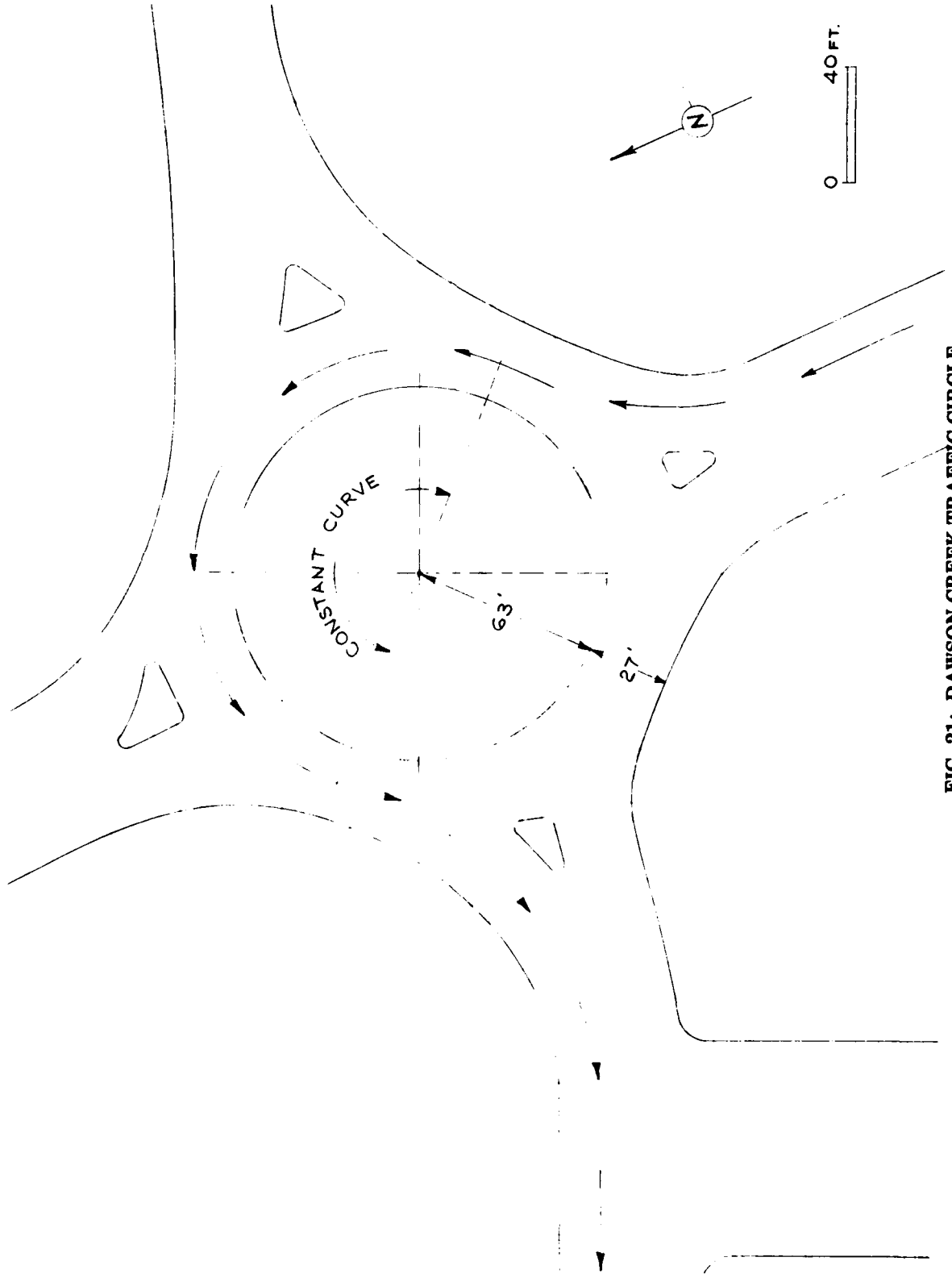

FIG. 21: DAWSON CREEK TRAFFIC CIRCLE

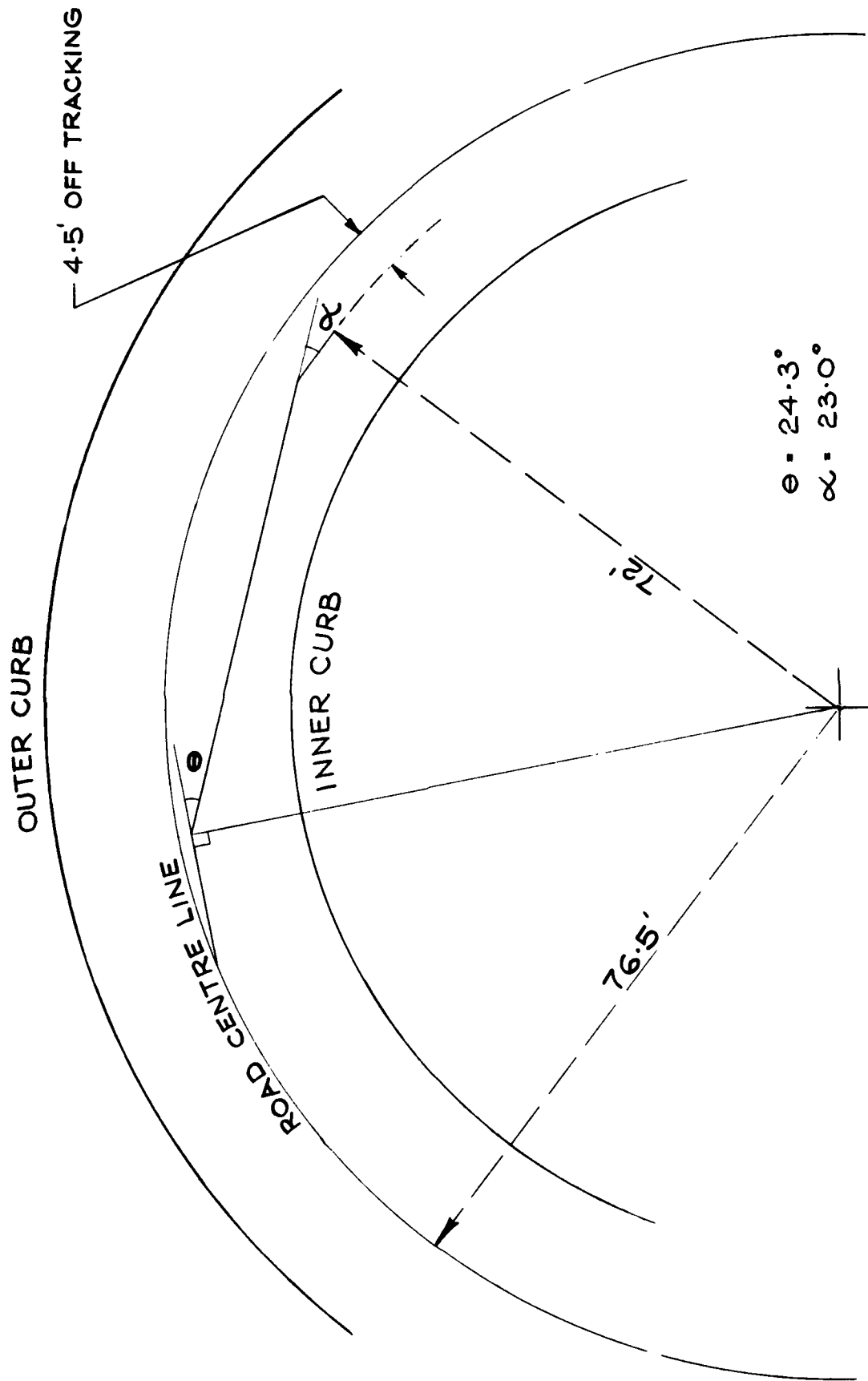

FIG. 22: GRAPHICAL SOLUTION USED TO SOLVE FOR OFF TRACKING KNOWING THE ANGLE OF THE LOAD TO THE TRACTOR

6.2 Steamboat Switch Back

Figure 23 is an aerial photograph of the switch back curve at Steamboat. Knowing the elevation and the camera focal length, the scale of the photograph was determined and thus the radius of curvature was acquired. The tightest curve radius, taken at the centre of the road, was 80 ft. with a reasonably constant radius arc of 90° lasting approximately 125 ft. The change in the roadway direction as a result of the switch back is approximately 320° .



FIG. 23: AERIAL PHOTOGRAPH OF THE SWITCH BACK CURVE AT STEAMBOAT
Scale 1:2200

Again from the data collected, it was learned that the dolly reached its maximum angular limit of 23° and remained at this point for approximately 75 ft.

By assuming a curve radius of 80 ft. and knowing that the maximum fifth wheel rotation was 24.3° , the maximum off tracking determined graphically was 6.3 ft.

Table 6 lists the radius of curvature as determined from the tractor steering angle and the subsequently off tracking determined graphically.

TABLE 6
RADIUS OF CURVATURE AS DETERMINED FROM TRACTOR STEERING ANGLE
AND THE OFF TRACKING DETERMINED GRAPHICALLY

Distance (Ft)	Measured Curve Radius (Ft)	Off Tracking (Ft)	Swept Area (Ft)
0	77	4.0	17.8
75	70	2.5	16.7
150	64	0.3	15.75
180	80	6.3	18.3

6.3 Roll Angle and Lateral Acceleration Results

The purpose of the roll meter and the lateral accelerometer was to supply a data source should the vehicle behave in an uncharacteristic way. The maximum lateral acceleration experience through a curve was 0.2 g. This occurred at Steamboat and there was direct agreement between the accelerometers in the pipe and on the dolly frame.

Visual inspection during the tests and subsequent analysis of the accelerometer traces revealed no dolly hunting either on straight stretches or during curving.

6.4 Road Test Comments

The dolly assembly required some adjustment to the steering linkage to properly align the dolly with respect to the tractor. Course adjustments were made before the calibration runs, but it was not until we were en route that the final adjustments were made. The crabbing offset before the final adjustment was in the order of six inches. The adjustment procedure involved turning a steering linkage adjustment nut which was accessible from under the dolly.

There was no evidence that the dolly hunted during the journey and there does not appear to be any problem with vehicle stability.

While in the Yukon, the air supply line to the dolly turntable compensator, which acts as a coulomb damper, was fractured. At that instant, the driver noticed a change in the response of the dolly, but it in no way affected his control. The vehicle was brought to a halt and the turntable was locked using the emergency lockout device. From that point, until the next city, Whitehorse, the dolly performed as a non-steering tri-axle dolly.

At the construction site near Quill Creek, the vehicle was off loaded on a bush road running parallel to the pipeline. Although the road was straight, it had some very severe dips, one of which was a -10% grade lasting approximately 98 ft. and then transforming to a +1.7% grade over a 33 ft. distance. Because the dolly can pitch with respect to the load and because it is relatively short, it was able to negotiate this dip without interference.

7.0 THEORETICAL COMPARISON OF THE DOLLY WITH RESPECT TO A SEMI-TRAILER

For the purpose of comparison, the following, Table 7, presents theoretical off tracking and swept areas of the ASTL tractor trailer assembly used during the tests with a "legal" 45-foot long, 10-foot wide, semi-trailer pulled by the same type of tractor.

TABLE 7

**THEORETICAL COMPARISON OF OFF TRACKING AND SWEEPED AREA
BETWEEN STEERING DOLLY AND A SEMI-TRAILER**

Curve Radius at Leading Axle of Tractor (Ft)	Off Tracking (Ft)		Swept Area (Ft)	
	Steering Dolly Max	Max 45' x 10' Semi-Trailer	Steering Dolly	45' x 10' Semi-Trailer
90	8.35	9.94	19.31	18.94
100	7.41	8.84	18.12	17.84
120	6.07	7.26	16.38	16.26
165	4.34	5.20	14.08	14.20
200	3.56	4.27	13.03	13.27

Notes: 1. The equations used in the calculation of the theoretical swept area are presented in Appendix B.

2. The calculations for the 45-foot long, 10-foot wide semi-trailer assume a fifth wheel pin to bogie centre distance of 38.5 feet. The cab width of the tractor was taken as 8 feet.

The values presented in the table are maximum theoretical values which would not likely be achieved in practice unless the curve being negotiated is very long. The SAE handbook suggests that off tracking steady state will occur when a vehicle's curving duration is 270° or greater. The rate with which the tractor trailer assembly approaches the theoretical off tracking limit is very rapid when the curve begins, but then diminishes as theoretical off tracking is approached. However, in practice, because most highway curves have lead in spirals, the error between theoretical and practical off tracking and swept area should not be too great.

It is not clear if theoretical off tracking of the steering dolly tested would be achieved under any condition. From the test program, it appears that practical off tracking of the dolly will be less than the theoretical limits. This holds true also for the swept area of the vehicle.

8.0 CONCLUDING REMARKS

1. The discrepancy between the theoretical and actual off tracking results from the Northlands Calibration tests indicate that the theoretical fundamental trigonometric approach gives a conservative approximation of the off tracking of the steering dolly for a particular curve.

To improve the theoretical model, a considerable effort would be required to assemble the differential equations necessary to describe the curving response of the vehicle. In addition, tire rolling effects such as lateral and longitudinal creep forces may have to be considered.

2. The theoretical steady state off tracking of the steering dolly is approximately 15% better than the theoretical steady state off tracking of the largest "legal" vehicle allowed on B.C. roads.

Because the theoretical off tracking of the dolly has proven to be conservative, this figure is also conservative. In addition, the calculations of swept area were based upon the theoretical off tracking results, therefore, the swept area results of Table 7 are conservative.

3. The performance of any road vehicle large or small is greatly dependent upon the skill of the operator. The Alaska Highway is a treacherous roadway with a high proportion of commercial traffic. This, coupled with the severe weather conditions, common to the region, places high demands on the drivers. Under these conditions, the driver's knowledge of the road or experience on a similar class of roadway becomes a significant factor in minimizing the accident risks. The selection of competent experienced drivers, therefore, is nearly as critical as the choice of the road vehicle itself.

4. These tests were done on specific equipment and in no way should these results prejudice the performance of other devices that could be generally categorized as steering trailers or dollies.

9.0 REFERENCES

1. Ervin, R.D. *Eliminating Yaw Instability in Tractor-Semitrailers during Cornering.*
Nisonger, R.L. H.S.R.I. Research Review, University of Michigan, Vol. 10, N1,
Mallikarjunarao, C. July, August, 1979.
2. SAE Handbook *Turning Ability of Off Tracking — Motor Vehicles — SAE J6956.*
Society of Automotive Engineers, Warrendale, Pa., Vol. II, 1980.

10.0 ACKNOWLEDGMENTS

The efforts of a number of people greatly contributed to the completion of this test program.

Among them, Mr. G. Nylander, the driver, whose knowledge of the highway, technical competence and general enthusiasm for the project were appreciated by all; Banister Transport — especially the efforts of Mr. P.J. Larkin, Mr. A.D. Thomas, Mr. E. Girroir and Mr. M. Cunningham, who worked closely with us during setup procedures; Mr. A. Turnbull, writer, photographer, for his help in setting up the calibration curves at Northlands Park and for his photographs contained herein, which were supplied to NRCC by Alberta Transportation; Mr. Wm.H. Wilson and Mr. D.E. Fulcher, Foothills Pipe Line (Yukon) Co., for their contribution prior to and during the test; Mr. R.B.L. Adams, Compliance Engineer, British Columbia Ministry of Transportation and Highways (BCMOTH), for his briefing and consultation during the project; to BCMOTH for allowing the vehicle to proceed on the Alaska Highway with axle loadings in excess of the legal limit, (this was done in the "interest of science"); Mr. N.R. Curry, President, ASTL Trailers Ltd., and Mr. A. Copes, Chief Engineer, Columbia Trailers Co. Ltd., for their technical input prior to the test program; Mr. B. Allen, NRCC Railway Laboratory for his continuously diligent efforts in instrumentation under trying circumstances and severe weather conditions.

APPENDIX A

The following graphs show the actual off tracking of the vehicle at Northlands Park, Edmonton. The off tracking shown is the curve radius difference between the steering axle of the tractor and the bogie centre of the dolly, i.e. $R_1 - R_2$.

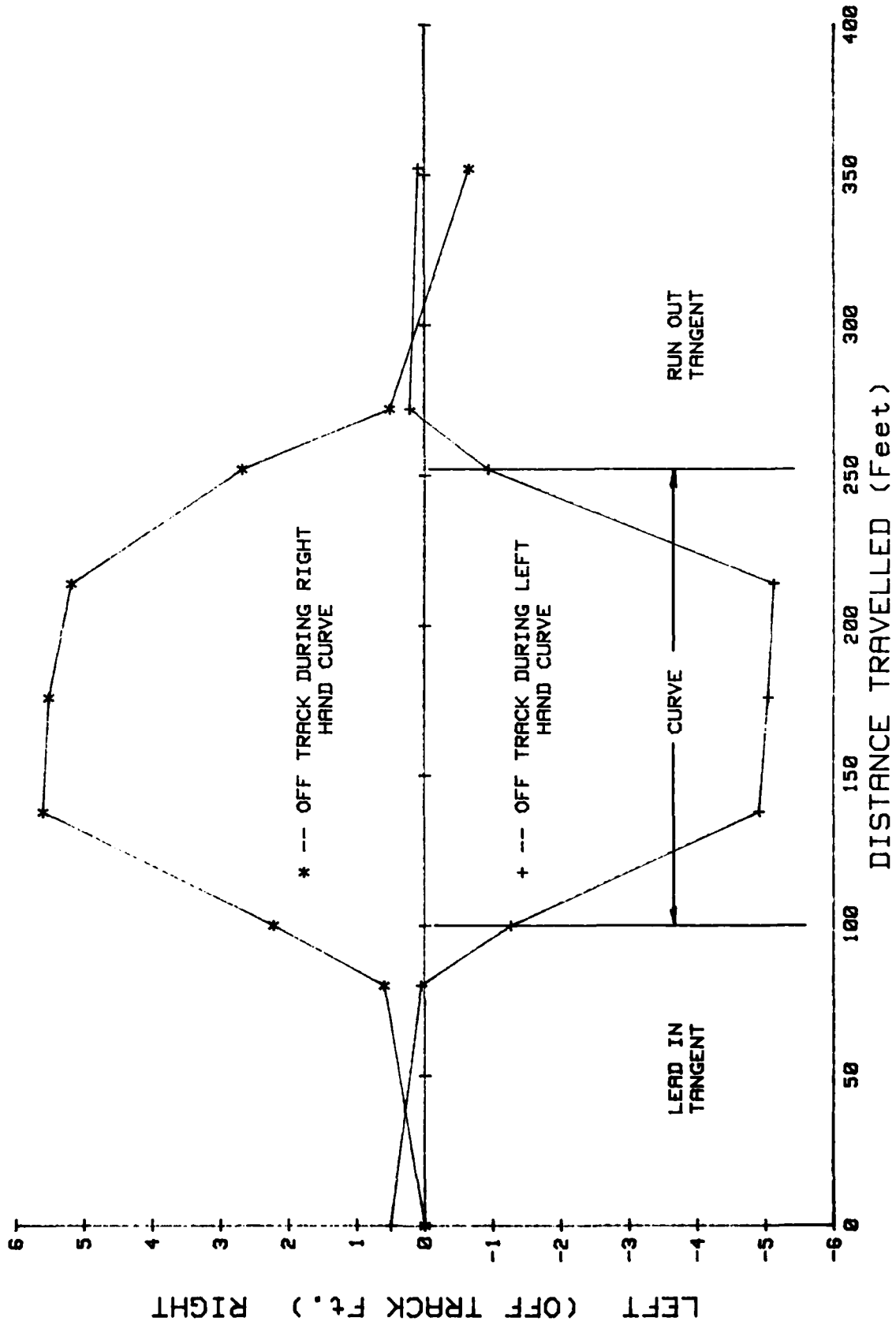

FIG. A-1: ACTUAL OFF TRACK DATA FROM NORTHLANDS CALIBRATION - 100 FT. RADIUS CURVE

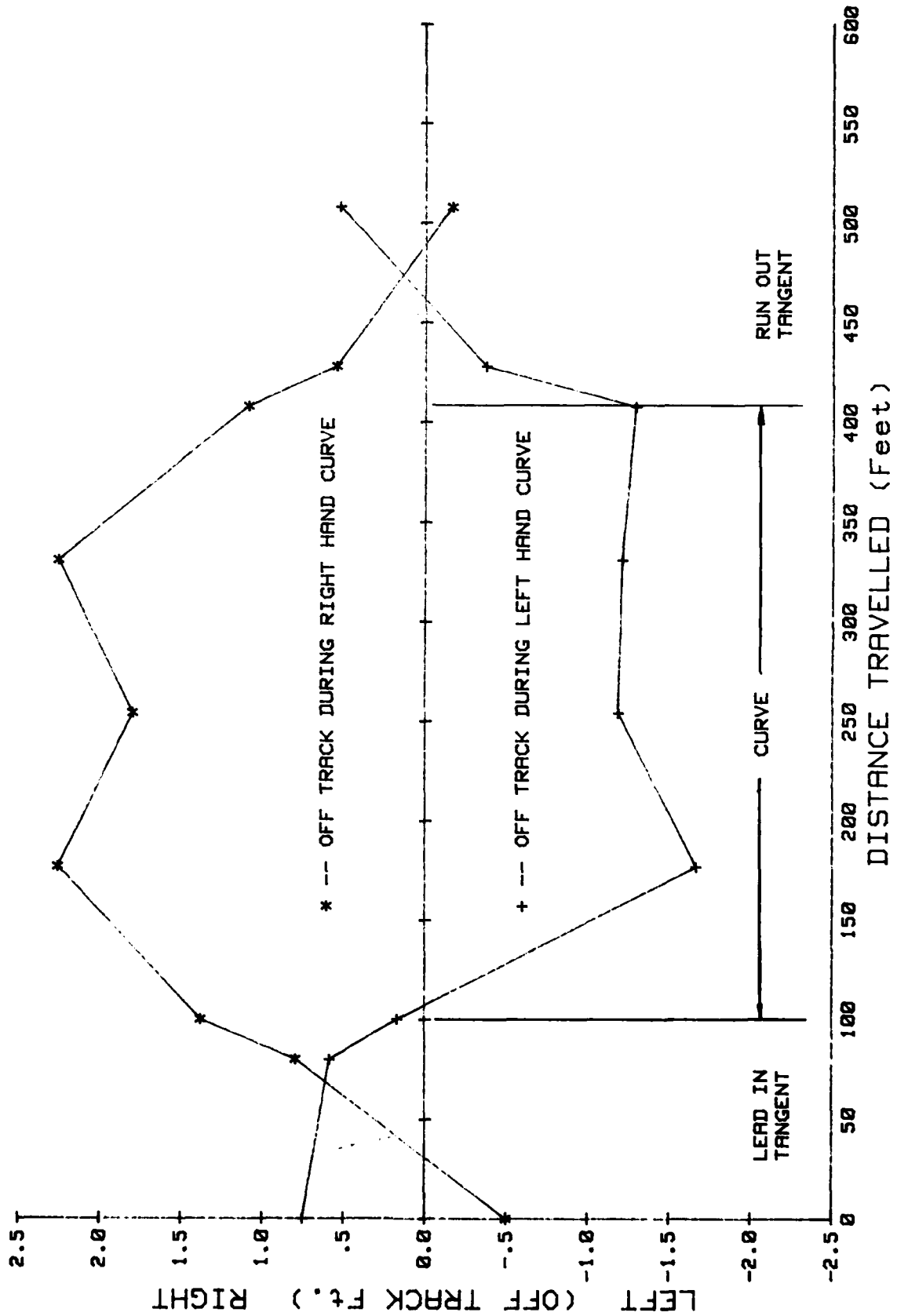

FIG. A-2: ACTUAL OFF TRACK DATA FROM NORTHLANDS CALIBRATION - 200 FT. RADIUS CURVE

APPENDIX B

Equations used to determine theoretical off tracking and swept area.

For ASTL dolly:

Nomenclature

T	truck wheelbase*
F	bogie centre to fifth wheel of tractor
D	dolly wheelbase*
P	bogie centre to turntable of dolly
L	fifth wheel pin to turntable load length
W	load width
F _{oh}	load overhang forward of the fifth wheel pin
R _{oh}	load overhang aft of the turntable centre
θ	angle of load with respect to dolly frame
R ₁	radius of curve at tractor axle centre
R ₂	radius of curve at fifth wheel
R ₃	radius of curve at tractor bogie centre
R ₄	radius of curve at dolly steering axle centre
R ₅	radius of curve at dolly turntable
R ₆	radius of curve at dolly bogie centre
R ₂₂	maximum radius at outermost corner of pipe at tractor end
R ₅₅	minimum radius at innermost corner of pipe overhang at dolly end
R ₅₆	maximum radius at outermost corner of pipe overhang at dolly end
R ₇	minimum radius along pipe length
S _r	steering ratio — dolly (1/1.625)

The equations follow.

For off tracking

$$R_4 = D/\sin(Sr \theta)$$

$$R_5 = (P^2 + R_6^2)^{1/2}$$

$$R_6 = D/\tan (Sr \theta)$$

$$Sr \theta = \tan^{-1} (D/R_6)$$

* Wheel is taken as the distance from the steering axle to the centre of the bogie.

$$\phi = 180 - \theta - \tan^{-1} \left(\frac{R_6}{P} \right)$$

$$R_2 = (L^2 + R_5^2 - (2LR_5 \cos\phi))^{1/2}$$

$$R_3 = (R_2^2 - F^2)^{1/2}$$

$$\therefore R_1 = (R_3^2 + T^2)^{1/2}$$

For swept area of the dolly, see Figure A-1

$$R_{22} = \left(Foh^2 + \frac{W^2}{4} + R_2^2 - 2 \left(Foh^2 + \frac{W^2}{4} \right)^{1/2} R_2 \cos \left(\tan^{-1} (W/2/Foh) + 180 - \cos^{-1} \left(\frac{(R_2^2 + L^2 - R_5^2)}{(2R_2L)} \right) \right) \right)^{1/2}$$

$$R_{55} = \left(R_5^2 + Roh^2 \frac{W^2}{4} - 2R_5 \left(Roh^2 + \frac{W^2}{4} \right)^{1/2} \cos \left(180 - \sin^{-1} (R_2 \sin(\alpha)/R_5) - \tan^{-1} (W/2/Roh) \right) \right)^{1/2}$$

$$R_{56} = \left(R_5^2 + Roh^2 \frac{W^2}{4} - 2R_5 \left(Roh^2 + \frac{W^2}{4} \right)^{1/2} \cos \left(180 - \sin^{-1} (R_2 \sin(\alpha)/R_5) + \tan^{-1} (W/2/Roh) \right) \right)^{1/2}$$

$$\text{where } \alpha = \cos^{-1} \left(\frac{(R_2^2 + L^2 - R_5^2)}{(2R_2L)} \right)$$

$$R_7 = R_2 \sin\alpha$$

For semi trailer — (assuming that the fifth wheel is at the centre of the tractor's tandem axle).

Nomenclature

T	tractor wheelbase
L_s	distance from the fifth wheel to the semi trailer bogie centre
W_s	width of the semi trailer
R_{1s}	radius of curve at tractor axle centre
R_{3s}	radius of curve at semi trailer bogie centre
R_{min}	innermost radius scribed by vehicle
R_{max}	outermost radius scribed by vehicle

$$R_{1s}^2 = L_s^2 + R_{3s}^2 + T^2$$

$$R_{min} = R_{3s} - \frac{W_s}{2}$$

$$R_{\max} = R_{1s} + \frac{1}{2} (\text{width of tractor})$$

For the tractor dolly configuration tested the following parameters apply: (all dimensions in feet).

T	=	14.5
F	=	0.417
L	=	53.0
D	=	13.75
P	=	6.83
Foh	=	7.42
Roh	=	19.0
W	=	8.06

For the tractor 45-foot semi trailer (all dimensions in feet).

T	=	14.42
L _s	=	38.5
W	=	10.0

Tractor cab width = 8 ft.

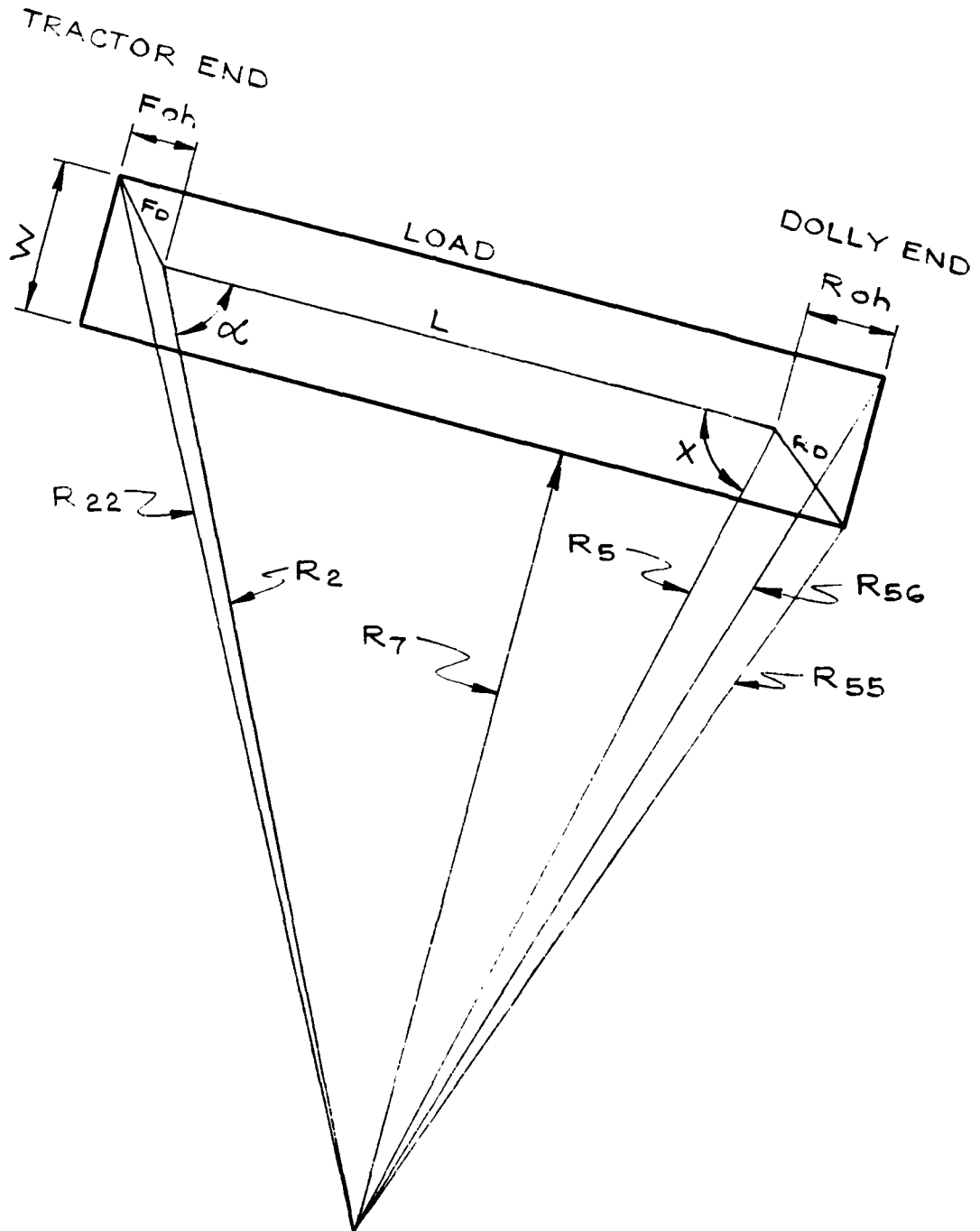

FIG. B-1: ILLUSTRATION OF TERMS USED IN THE CALCULATION OF THEORETICAL SWEEP AREA

The following is a computer listing and sample output for the calculation of radii of curvature at various points along the vehicle, off tracking, excursion limits and swept area. This was programmed on a Hewlett-Packard 9835A desktop computer using the language "BASIC".

```

10 | ***** NOVA 8 *****
20 |
30 | ASTI GENERALIZED CURVING PROGRAM
40 | *****
50 | THIS PROGRAM ACCOUNTS FOR THE POSITION OF THE TRACTOR'S
60 | 5th WHEEL AND THE LOCATION OF THE DOLLY TURN TABLE WRT
70 | THE BOGIE CENTRES.
80 |
90 | *****
100 | J. Woodroffe March 30, 1981
110 | *****
120 | *****
130 |
140 | PRINTER IS 7,1
150 | DEG
160 | FIXED 4
170 |
180 | *****
190 | ***** ALL DIMENSIONS IN FEET *****
200 | *****
210 | *****
220 | ***** TRACTOR SPECS. *****
230 |
240 | T=14.5 | TRACTOR WHEELBASE (Front axle to bogie centre)
250 | F=.4167 | TRACTOR 5th WHEEL CENTRE WRT BOGIE CENTRE
260 | L=53 | LOAD LENGTH (5th wheel to dolly turn table centres)
270 |
280 | ***** DOLLY SPECS. *****
290 |
300 | D=13.75 | DOLLY WHEEL BASE (Front axle to bogie center)
310 | Th=0 | STEERING ANGLE AT DOLLY STEERING AXLE
320 | P=6.833 | DOLLY TURN TABLE CENTRE WRT BOGIE CENTRE
330 | Dts=17.6125 | DOLLY - TURN TABLE / STEERING ANGLE RATIO
340 |

```

Copy available to DTIC does not permit fully legible reproduction

PREVIOUS PAGE BLANK-NOT FILLED

```

700 R1=(T^2+R3^2)^.5
710 IF R1<200 THEN 620  ! CURVE RADIUS REQUIRED AT TRACTOR STEERING AXLE.
720 A1=ASN(1.*SIN(180-Dt+XTh-A1N(R6/P)))/(R6+XCDIG(180-Dt+XTh-A1N(R6/P)))+(180-Dt
XTh-A1N(R6/P))-ACS(F/R2)
730 R22=(Foh^2+W^2/4+R2^2-2*(Foh^2+W^2/4)^.5*RP*COG(ATN(W/2/foh)+180-ACS((R2^2+
L^2-R5^2)/(2*R2*XL)))^).5
740 Alp=ACS((R2^2+L^2-R5^2)/(2*R2*XL))
750 X=ASN(R2*SIN(Alp)/R5)
760 Rm=R5*SIN(X)-W/2
770 R5mn=(R5^2+Roh^2+W^2/4-2*R5*(Roh^2+W^2/4)^.5*COG(180-ASN(R2*SIN(Alp)/R5))-AT
N(W/2/Roh))^).5
780 R5mx=(R5^2+Roh^2+W^2/4-2*R5*(Roh^2+W^2/4)^.5*COG(180-ASN(R2*SIN(Alp)/R5))+AT
N(W/2/Roh))^).5
790 Ot=R1-R6
800 So=R22-Rm
810 PRINT "*****"
820 PRINT " "
830 PRINT "DOLLY LOAD ANGLE=";Th;" K1=";R1;" E2=";R2;" R3=";R3;" R4=";R4;"
R5=";R5;" R6=";R6;" TRACTOR LOAD ANGLE=";Al
840 PRINT " "
850 PRINT "OFF TRACKING (R1-R6)=";Ot
860 PRINT " "
870 PRINT "++++"
880 PRINT " "
890 PRINT "PIPE EXCURSION RADIUS FRONT =";R22;" MIN RADIUS ALONG PIPE=";Rm
900 PRINT "PIPE EXCURSION RADIUS REAR;( MIN=";R5mn;" ; MAX=";R5mx;" )"
910 PRINT " "
920 PRINT "SWEEP AREA OF PIPE=";So
930 PRINT " "
940 PRINT "*****"
950 PRINT " "
960 PRINT " "
970 PRINT " "
980 END

```

Copy available to DnC does not permit fully legible reproduction

```
*****  
DOLLY LOAD ANGLE= 6.5215 R1= 200.4702 R2= 199.7456 R3= 199.9452 R4=  
197.3895 R5= 197.0285 R6= 196.9100 TRACTOR LOAD ANGLE= 6.9598  
OFF TRACKING (R1-R6)= 3.5602  
+++++  
PIPE EXCURTION RADIUS FRONT = 205.3975 MIN RADIUS ALONG PIPE= 192.3807  
PIPE EXCURTION RADIUS REAR: ( MIN= 195.4630 ; MAX= 203.4034 )  
SWEEP AREA OF PIPE= 13.0168  
*****
```

Copy available to DTIC does not
permit fully legible reproduction