

AD-A114 791

MATERIALS RESEARCH LABS ASCOT VALE (AUSTRALIA)
A MINIATURE IONIZATION PROBE TECHNIQUE USING A MULTILAYER CIRCU--ETC(U)
MAY 81 R J SPEAR, J R BENTLEY, M G WOLFSON

F/6 9/5

UNCLASSIFIED

MRL-R-815

NL

[]

[]

[]	[]	[]	[]	[]	[]	[]	[]	[]	[]	[]	[]	[]	[]
[]	[]	[]	[]	[]	[]	[]	[]	[]	[]	[]	[]	[]	[]

END
DATE
FILMED
6 82
DTIC

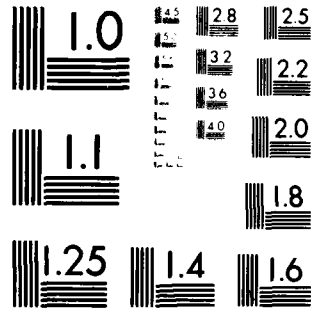

MICROCOPY RESOLUTION TEST CHART
NATIONAL BUREAU OF STANDARDS 1963-A

12



AD A 1 1 4 7 9 1

**DEPARTMENT OF DEFENCE
DEFENCE SCIENCE AND TECHNOLOGY ORGANISATION
MATERIALS RESEARCH LABORATORIES**

MELBOURNE, VICTORIA

REPORT

MRL-R-815

A MINIATURE IONIZATION PROBE TECHNIQUE USING A MULTILAYER
CIRCUIT BOARD FOR THE STUDY OF EXPLOSIVE PHENOMENA
IN PRIMARY AND SECONDARY EXPLOSIVES

Robert J. Spear, John R. Bentley and Michael G. Wolfson

Approved for Public Release

DTIC FILE COPY



DTIC
ELECTE
MAY 24 1982
S D
A

© COMMONWEALTH OF AUSTRALIA 1981

82 05 24 004 MAY, 1981

**DEPARTMENT OF DEFENCE
MATERIALS RESEARCH LABORATORIES**

REPORT

MRL-R-815

**A MINIATURE IONIZATION PROBE TECHNIQUE USING A MULTILAYER
CIRCUIT BOARD FOR THE STUDY OF EXPLOSIVE PHENOMENA
IN PRIMARY AND SECONDARY EXPLOSIVES**

Robert J. Spear, John R. Bentley and Michael G. Wolfson

ABSTRACT

A miniature ionization probe technique using a multilayer circuit board has been developed. Full experimental details including construction of the boards, explosive charge preparation and instrumentation are reported. Each copper layer in the circuit board functions as an ionization probe and optimum conditions were achieved with a probe density of 15 per cm, ie, probe separation about 0.75 mm. Explosive samples were studied in a geometry similar to that of practical fuze detonators; the pressed explosive columns were 5-8 mm long and masses ranged from 0.58 g to only 0.08 g. Accurate, reproducible detonation velocity measurements have been obtained for the primary explosives service lead azide, at a wide range of densities, lead azide RD1343, silver azide and mercuric 5-nitro-tetrazole and the secondary explosive tetryl. Some potential improvements and future uses of the technique are discussed.

Approved for Public Release

© COMMONWEALTH OF AUSTRALIA 1981

**POSTAL ADDRESS: Chief Superintendent, Materials Research Laboratories
P.O. Box 50, Ascot Vale, Victoria 3032, Australia**

DOCUMENT CONTROL DATA SHEET

Security classification of this page:

UNCLASSIFIED

1. DOCUMENT NUMBERS:	2. SECURITY CLASSIFICATION:
a. AR Number: AR-002-415	a. Complete document: UNCLASSIFIED
b. Series & Number: REPORT MRL-R-815	b. Title in isolation: UNCLASSIFIED
c. Report Number: MRL-R-815	c. Abstract in isolation: UNCLASSIFIED

3. TITLE: A MINIATURE IONIZATION PROBE TECHNIQUE USING A MULTILAYER CIRCUIT BOARD FOR THE STUDY OF EXPLOSIVE PHENOMENA IN PRIMARY AND SECONDARY EXPLOSIVES

4. PERSONAL AUTHOR(S): SPEAR, Robert J. BENTLEY, John R. WOLFSON, Michael G.	5. DOCUMENT DATE: MAY, 1981
6. TYPE OF REPORT & PERIOD COVERED:	

7. CORPORATE AUTHOR(S): Materials Research Laboratories	8. REFERENCE NUMBERS: a. Task: DST 71/011 b. Sponsoring Agency:
9. COST CODE: 221372	

10. IMPRINT (Publishing establishment) Materials Research Laboratories, P.O. Box 50, Ascot Vale, Vic. 3032 MAY, 1981	11. COMPUTER PROGRAMME(S): (Title(s) and language(s)):
---	---

12. RELEASE LIMITATIONS (of the document):

Approved for Public Release

12-0. OVERSEAS: N.O. P.R. 1 A B C D E

13. ANNOUNCEMENT LIMITATIONS (of the information on this page):
No Limitation

14. DESCRIPTORS:
630 / Detonation / Velocity measurement / Circuit boards //
636 / Ionization probes //

15. COSATI CODES: 1402 //

16. ABSTRACT (if this is security classified, the announcement of this report will be similarly classified):
A miniature ionization probe technique using a multilayer circuit board has been developed. Full experimental details including construction of the boards, explosive charge preparation and instrumentation are reported. Each copper layer in the circuit board functions as an ionization probe and optimum conditions were achieved with a probe density of 15 per cm, ie, probe separation about 0.75 mm. Explosive samples were studied in a geometry similar to that of practical fuze detonators; the pressed explosive columns were 5-8 mm long and masses ranged from 0.58 g to only 0.08 g. Accurate, reproducible detonation velocity measurements have been obtained for the primary explosives service lead azide, at a wide range of densities, lead azide RD1343, silver azide and mercuric 5-nitrotetrazole and the secondary explosive tetryl. Some potential improvements and future uses of the technique are discussed.

C O N T E N T S

	<u>Page No.</u>
1. INTRODUCTION	1
2. EXPERIMENTAL SECTION	2
2.1 <i>Manufacture of Multilayer Circuit Boards</i>	2
2.2 <i>Preparation of Explosive Charges</i>	2
2.2.1 <i>Charges Initiated by Lead Azide Fusehead</i>	3
2.2.2 <i>Charges Initiated by Hot Wire</i>	3
2.3 <i>Explosive Materials</i>	3
2.4 <i>Firing and Recording Instrumentation</i>	3
2.4.1 <i>General Description</i>	3
2.4.2 <i>Firing Circuit</i>	4
2.4.3 <i>Event Pulse Circuit</i>	4
2.4.4 <i>The Cathode Ray Oscilloscope (CRO)</i>	4
2.4.5 <i>Alternative Triggering Method</i>	4
3. RESULTS AND DISCUSSION	5
3.1 <i>Service Lead Azide. Density Dependence of V of D</i>	5
3.2 <i>Hot Wire Initiation. Lead Azide RD1343, Silver Azide and Mercuric 5-Nitrotetrazole</i>	5
3.3 <i>Tetryl</i>	6
4. CONCLUSION	6
5. ACKNOWLEDGEMENTS	7
6. REFERENCES	7



Accession For	
NEWS GRASS	<input checked="" type="checkbox"/>
DEPT TAB	<input type="checkbox"/>
MANAGEMENT	<input type="checkbox"/>
JUSTIFICATION	<input type="checkbox"/>
by _____	
Initials _____	
Date _____	

A	

C O N T E N T S

(Continued)

	<u>Page No.</u>
TABLE 1 - DETONATION VELOCITIES OF PRESSED SERVICE LEAD AZIDE OF VARIOUS DENSITIES	8
TABLE 2 - DETONATION VELOCITIES OF PRESSED LEAD AZIDE RD1343, SILVER AZIDE AND MERCURIC 5-NITROTETRAZOLE	9
TABLE 3 - DETONATION VELOCITIES OF PRESSED TETRYL INITIATED BY LEAD AZIDE	10
FIG. 1 - Illustration of Multilayer Board with Circuit Layers Wired for Connection to Event Pulse Circuit	11
FIG. 2 - Configuration of Multilayer Boards for Explosive Filling	
(a) For charges to be initiated by Lead Azide fusehead (electrical leads are not shown)	
(b) For charges to be initiated by hot wire (electrical leads are not shown)	12
FIG. 3 - Pressing Mould for Explosive Filling of Multilayer Board	13
FIG. 4 - Block Diagram of Firing and Recording Instrumentation for Multilayer Board	14
FIG. 5 - Event Pulse Circuit for Multilayer Board	15
FIG. 6 - Typical CRO Trace of Event Pulses for Service Lead Azide Initiated by Fusehead	15
FIG. 7 - Plot of Detonation Velocity Versus Density for PRESSED Service Lead Azide	16
FIG. 8 - Typical CRO Trace of Event Pulses for Hot Wire Initiated Charges: Mercuric 5-nitrotetrazole	17
FIG. 9 - Typical CRO Trace of Event Pulses for Tetryl Initiated by Lead Azide	17

A MINIATURE IONIZATION PROBE TECHNIQUE USING A MULTILAYER
CIRCUIT BOARD FOR THE STUDY OF EXPLOSIVE PHENOMENA IN
PRIMARY AND SECONDARY EXPLOSIVES

1. INTRODUCTION

Detonators, the small explosive devices employed in the initial segment of an explosive train, usually consist of a few millimetres of primary explosive followed by a similar increment of a shock sensitive secondary explosive such as RDX or tetryl. Their small size presents considerable experimental difficulties to quantitative measurement of their explosive output. This problem is commonly encountered in studies of explosive phenomena in primary explosives, where both distances and times for explosive buildup following initiation are typically very short.

We decided to develop a method by which the velocity of detonation (V of D) of the explosive components of a detonator could be accurately measured. V of D measurements and related explosive phenomena are normally determined by ultra high speed photographic [1,2,3], ionization probe [3,4], strain gauge [3,4] or fibre optic photodetection [5] techniques. High speed photography has been extensively used for primary explosives, particularly for fast decomposition of single crystals [2]. However, streak cameras are difficult to set up and reading velocities from records of small samples is relatively inaccurate. Ionization probe and strain gauge techniques have been mainly used for studying secondary explosives [4] where sample sizes are usually several cm or longer. Clearly the problem of modifying either of these two methods to study the fast reactions in primary explosives is one of miniaturisation. Growth to detonation has recently been observed in exploding bridgewire (EBW)-initiated PETN [5] using up to four fibre optic probes positioned along an 11.0 mm charge, hence this technique offers considerable promise for the study of small samples.

We chose, as our experimental method, miniaturisation of the ionization probe technique by utilizing a multilayer circuit board where each copper layer functions as an ionization probe. Probe densities of up to 50/cm have been tested but with columns of explosive 5-8 mm long and using a single sweep cathode ray oscilloscope (CRO) 15 probes per cm has proved most

successful, giving a separation of about 0.75 mm between probes. We report here experimental details of the multilayer circuit board including construction, explosive charge preparation and instrumentation. The accuracy and reproducibility of V of D measurements obtained using the technique is amply demonstrated. Results are reported for a number of primary explosives and the secondary explosive tetryl obtained from samples ranging from 0.58 g to only 0.08 g. A number of potential improvements and further applications of the experimental technique are discussed.

2. EXPERIMENTAL SECTION

2.1 Manufacture of Multilayer Circuit Boards

Multilayer circuit boards were constructed from double sided copper clad glass epoxy laminate board, 152.5 x 152.5 mm, copper thickness 0.038 mm, commercially available from Formica Inc., and "B" stage pre-preg, nominal thickness 0.1 mm. The laminate boards were initially formed into printed circuits by etching nineteen parallel 2.03 mm strips on each copper side using standard techniques. A large multilayer board was prepared by placing 5 pre-preg layers alternately between each of five etched laminate boards aligned so that the etched strips coincided exactly. The boards were then cured under the conditions of temperature and pressure specified by Formica Inc. The finished board thus had ten copper layers where each copper layer consisted of twenty identical parallel copper strips. The exact spacings between copper layers varied from batch to batch and were accurately determined by metrology of test holes and machined sections.

Individual multilayer boards for experimental studies were prepared by cutting the large boards down every alternate etched spacer. One end of each individual board was then machined with an angled cut of about 30° and the laminate and pre-preg was scraped from the machined section to expose thin copper strips on either side of the central spacer. One wire of a ten core rainbow ribbon was soldered to each of the exposed copper strips on one side of the spacer with a common lead soldered to the copper strips on the other side. The finished assembly, with drilled hole for explosive filling (see Section 2.2), is illustrated in Figure 1. Note that the hole must be wider than the spacer so that the copper strips on either side are partly cut.

2.2 Preparation of Explosive Charges

All charges were pressed using an Eltor floating table press. Pressing loads were varied to give the required filling densities. Primary explosives were pressed incrementally directly into the multilayer boards. Tetryl was pre-pressed into pellets and subsequently pressed into the boards. Charge lengths, diameters and the position of interfaces and probes were determined radiographically.

After firing each charge the multilayer board was cut and prepared for reuse. Several experimental firings could thus be obtained from each board.

2.2.1 Charges Initiated by Lead Azide Fusehead

A trigger probe consisting of a bakelite insulating strip and an etched printed circuit board with attached leads was affixed to the bottom of a multilayer board as shown in Figure 2a. The board was then drilled out through the central spacer (Figure 2a) using a 4.12 mm drill. The multilayer board was clamped top downwards in the pressing mould detailed in Figure 3 with the holes in the board and mould aligned. The explosive to be studied was added and then pressed in 0.1 g increments. When the filling was to consist of two separate explosives, the pre-pressed pellet of tetryl was placed in first and the primary explosive was then pressed in. The boards were filled to within 1 mm of the trigger probe. A lead azide fusehead, prepared by dipping a bridgewire into a suspension of fine lead azide and ethyl cellulose in ethanol/ethyl acetate (1:1) and allowing to dry, was fitted prior to firing.

2.2.2 Charges Initiated by Hot Wire

The complete assembly detailed in Figure 2b was constructed by initially cementing a multilayer board and a bakelite strip with araldite and drilling out through the spacer with a 4.12 mm drill. A second drilled bakelite strip and a bridgewire device were then affixed to the bottom with araldite. The explosive was filled and pressed using the pressing mould detailed in Figure 3; the terminals of the bridgewire device fitted into an additional brass holder which sat on the lower plate of the pressing mould. The explosive was added and pressed in approximately 0.1 g increments until the charge was 1-2 mm from the top.

2.3 Explosive Materials

Service lead azide and lead azide RD1343 were obtained from MFF St Mary's, NSW, Australia.

Silver azide was prepared by reaction of ammoniacal silver nitrate with sodium azide in the presence of potassium bicarbonate [6].

Mercuric 5-nitrotetrazole was prepared from 5-aminotetrazole via sodium 5-nitrotetrazole dihydrate according to the method of Jenkins and White [7].

Tetryl was stock held at MRL, originally obtained from US sources.

2.4 Firing and Recording Instrumentation

2.4.1 General Description

A block diagram of the firing and recording instrumentation is shown in Figure 4. Triggering pulses for the Low Voltage Firing Unit and the Cathode Ray Oscilloscope (CRO) are derived from the Digital Delay Pulse Generator. The CRO sweep can thus be accurately delayed relative to the firing pulse to compensate for the inherent initiation delay, which is a combination of the

functioning time of the bridgewire initiating device and the buildup time to detonation of the explosive. This is important if good synchronisation is to be achieved, as the delay time can be long compared with the functioning time of the detonating high explosive. The sweep time of the CRO can therefore be minimised and the time resolution accordingly maximised.

Individual circuit board layers (Figure 1) act as ionisation probes or switches and are connected to capacitor discharge pulse circuits (Figure 5) which are powered by the Probe Power Supply. When detonation occurs the circuit board probes are progressively shorted and the resultant event pulses are applied to the signal input of the CRO and recorded using a "Polaroid" camera. A 2 MHz Time Mark Generator provides timing marks at 0.5 μ s intervals on the CRO trace. A 5 MHz time mark signal is used for very fast sweep speeds.

2.4.2 Firing Circuit

The firing circuit consists of a 16 μ F capacitor charged to 280 V, providing an energy output of 0.63 J, which is discharged into the platinum wire of the bridgewire device. The bridgewire resistance is 0.30 ohm \pm 0.05 ohm and the firing circuit resistance is 1.0 ohm.

2.4.3 Event Pulse Circuit

The circuit diagram is shown in Figure 5. There are nine identical circuits each with a 68 pF capacitor and one with a 270 pF capacitor, the latter connected to the last circuit board layer to aid in pulse identification. The value of 68 pF was chosen to ensure that event pulses do not overlap, which would reduce the measurement accuracy of the time intervals. A UR 70 coaxial signal cable from the output is terminated in 75 ohms at the CRO signal input, producing + 150 V pulses from the capacitor discharge circuits when charged to - 300 V.

2.4.4 The Cathode Ray Oscilloscope (CRO)

The instrument used was an ARF MK 2R High Voltage Oscilloscope, obtained from the UKAEA 15 years ago, which produces sweep times from 1 μ s to 64 μ s. Sweep times of 2 μ s and 4 μ s were normally used in this work. Because the signal is applied directly to the plates of the cathode ray tube, and not through an amplifier, the inherent rise time is fast. Some modern CRO or transient recorders would also be suitable.

2.4.5 Alternative Triggering Method

The initiation times of primary explosives such as lead azide varied to the extent that use of a set delay between the firing pulse and CRO often resulted in lost event pulses. In the lead azide fusehead initiated firing, a stable detonation was set up prior to the first multilayer ionization probe and the synchronisation problem was overcome by the use of a trigger probe. The trigger probe consisted of an etched printed circuit board which was glued to the bottom of the multilayer board, separated by a 3 mm thick insulating

layer (see Section 2.2.1 and Figure 2). The probe produced a reliable trigger pulse upon initiation of the explosive and gave good synchronisation between the CRO and event. The 3 mm lead in helped ensure that stable detonation was observed over the length of explosive contained in the multilayer board and also allowed for the 1 μ s inherent trigger delay of the CRO. This method could not be used in the hot wire initiated firings because the regimes prior to attainment of steady state detonation were also being investigated.

3. RESULTS AND DISCUSSION

3.1 Service Lead Azide. Density Dependence of V of D

Charges of service lead azide ranging in mass from 0.420 g to 0.583 g were pressed at varying pressing loads to give a range of densities (Table 1). All charges had a diameter of 4.17 ± 0.01 mm. The charges were fired using a lead azide fusehead with a trigger probe connected. Only the first 9 probes were connected and a typical CRO output is shown in Figure 6. Detonation velocities were calculated by least squares analysis and are listed, with standard deviations, in Table 1. A plot of V of D versus lead azide density is shown in Figure 7.

The data clearly illustrate the accuracy and time resolution of the experimental method. Detonation velocities compare favourably with literature values [3] and small changes in density are readily detected as changes in detonation velocity.

3.2 Hot Wire Initiation. Lead Azide RD1343, Silver Azide and Mercuric 5-Nitrotetrazole

Charges of lead azide RD1343 (400-450 mg), silver azide (425-450 mg) and mercuric 5-nitrotetrazole (320-350 mg) were pressed at 166 MPa. The charges were fired by capacitor discharge through the bridgewire with the CRO triggered by the delay pulse generator. Delay times, estimated from functioning time measurements on experimental detonators from a previous study [8], were:- lead azide RD1343, 4.0 μ s; silver azide, 4.5 μ s; mercuric 5-nitrotetrazole, 8.0 μ s. Sweep times of 4.0 μ s were normally used. Variation in initiation times, particularly for mercuric 5-nitrotetrazole, resulted in a number of experiments where some or all of the event pulses were lost. A CRO output where all event pulses were recorded is shown in Figure 8.

In principle, information such as times and distances for build-up to detonation could be obtained in addition to detonation velocities. However, as can be seen in Figure 8, the first three pulses which would cover the buildup time cannot be resolved. Any attempt to obtain information from this initial section of the explosive profile is beyond the scope of this report - we are currently examining this in further detail. Detonation velocities, obtained by least squares analysis of the data from the final seven probes, are listed in Table 2. The V of D data for lead and silver azide are consistent with literature values [3]. No V of D for mercuric 5-nitrotetrazole appears to have been reported previously.

3.3 Tetryl

Service Lead azide/tetryl charges were prepared as described in section 2.2 and were fired from a lead azide fusehead with a trigger probe connected. The normal arrangement was a short lead azide increment followed by the tetryl which covered most probes of the multilayer board. Only the first 9 probes were connected and a typical CRO output is shown in Figure 2. Detonation velocities were calculated by least squares analysis of the data and are listed, together with standard deviations, in Table 3. Two charges were prepared and fired with comparable lead azide and tetryl incremental lengths and V of D data for both explosives were obtained (Table 3).

The time resolution of the multilayer board technique is again readily apparent. Detonation velocities are reproducible and compare well with reported values [9] even on charges as small as 0.082 g. Detonation velocities increase with density, as expected. The higher standard deviations for the V of D on the small tetryl charges as well as the corresponding lead azide figures (Table 3, footnote a) result from the smaller number of probes triggered by each explosive and consequently the greater inaccuracy of the least squares analysis. Accurate data for masses smaller than those studied here could be achieved by using smaller charge diameters or multilayer boards where the probes were more closely spaced provided the instrumentation had sufficient time resolution.

4. CONCLUSION

The multilayer board ionization probe technique can accurately and reproducibly measure detonation velocities for primary and secondary explosives. Construction of the multilayer boards and sample preparation are both straight-forward. Complex instrumentation is not required although further improvement to the method could be achieved by suitable instrumentation. Specifically, a 100 MHz transient recorder could simplify the recording of event pulses and measurement of time intervals and would also remove the need for set time delays and trigger probes.

Since sample sizes are comparable with practical fuze detonators, the technique could readily be used to measure the V of D in the explosive components of a representative detonator. This should enable determination of the minimum amount of primary explosive and hence optimisation of detonator output. At present this procedure requires a large number of experimental firings using qualitative methods and the results can still be misleading. Testing of new candidate primary explosives should also be readily accommodated by the multilayer board technique.

We plan to extend our studies to explosive processes such as initiation, deflagration to detonation and primary-secondary interfacing. A major part will be the continuation of studies of hot wire initiation, particularly with regard to the initial explosive regimes.

5. ACKNOWLEDGEMENTS

Mr P.P. Elischer is especially thanked for assistance with preparation of the multilayer boards including explosive filling and development of the pressing mould. The technical assistance of Mr T.R. Watt, Mr G. Capolicchio, Mr P.J. Sanders, Mr B.W. Whiffen and Metrology Section are also gratefully acknowledged.

6. REFERENCES

1. Griffiths, N. and Grocock, J.M. (1960). *J. Chem. Soc.*, 4154.
2. Chaudhri, M.M. and Field, J.E. (1977). "Fast Decomposition in the Inorganic Azides", in *Energetic Materials*, Vol. 1., ed. Fair, H.D. and Walker, R.F., Plenum Press, New York, N.Y. Chapter 8, p. 383.
3. Voreck, W., Slagg, N. and Avrami, L. (1977). "The Role of Azides in Explosive Trains", in *Energetic Materials*, Vol. 2 ed. Fair, H.D. and Walker, R.F., Plenum Press, New York, N.Y. Chapter 7, p. 249.
4. Price, D. and Bernecker, R.R. (1975). *Combustion and Flame*, 25, 91, and earlier studies cited therein.
5. Mohler, J.H., Moodie, W.J., Haws, L.D. and Hall, G.F. (1978). *Combustion and Flame*, 32, 285, and earlier studies cited therein.
6. Bentley, J.R. MRL unpublished results.
7. Jenkins, J.M. and White, J.R. (1970). *ERDE TN 21*.
8. Spear, R.J. MRL unpublished results.
9. Urbanski, T. (1965). *Chemistry and Technology of Explosives*, Pergamon Press, London. Vol. III. p. 40.

T A B L E 1

DETONATION VELOCITIES OF PRESSED
SERVICE LEAD AZIDE OF VARIOUS DENSITIES

DENSITY (Mg/m ³)	SAMPLE MASS (g)	V of D (m/s)	STANDARD DEV. (m/s)
2.68 ^a	0.420	3530	15
2.75	0.430	3570	15
2.95	0.430	3720	20
3.30	0.460	3950	20
3.58	0.569	4300	25
3.87	0.583	4710	25
3.97	0.569	4870	30

a Very lightly pressed.

T A B L E 2

DETONATION VELOCITIES OF PRESSED LEAD AZIDE RD1343,
SILVER AZIDE AND MERCURIC 5-NITROTETRAZOLE

SAMPLE	MASS (g)	DENSITY (Mg/m ³)	V of D (m/s)	STANDARD DEV. (m/s)
LEAD AZIDE RD1343	0.350	3.68	4630	45
LEAD AZIDE RD1343	0.350	3.62	4280	90
SILVER AZIDE	0.450	4.13	5300	225
SILVER AZIDE	0.425	4.01	5740	25
MERCURIC 5-NITROTETRAZOLE	0.300	2.76	6310	115

T A B L E 3

DETONATION VELOCITIES OF PRESSED
TETRYL INITIATED BY LEAD AZIDE

CHARGE DIMENSIONS			DENSITY (Mg/m ³)	V of D (m/s)	STANDARD DEV. (m/s)
MASS (g)	LENGTH (mm)	DIAMETER (mm)			
0.162	7.36	4.17	1.615	7610	45
0.137	6.24	4.16	1.615	7660	85
0.082 ^a	3.72	4.17	1.620	7640	140
0.083 ^a	3.70	4.17	1.640	7670	60
0.171	7.65	4.14	1.660	7650	30
0.153	6.75	4.16	1.665	7805	35
0.153	6.66	4.18	1.675	7920	85

a V of D of lead azide was also obtained
 $d = 3.6 \text{ Mg/m}^3$, V of D = $4340 \pm 80 \text{ m/s}$
 3.7 Mg/m^3 , V of D = $4460 \pm 140 \text{ m/s}$

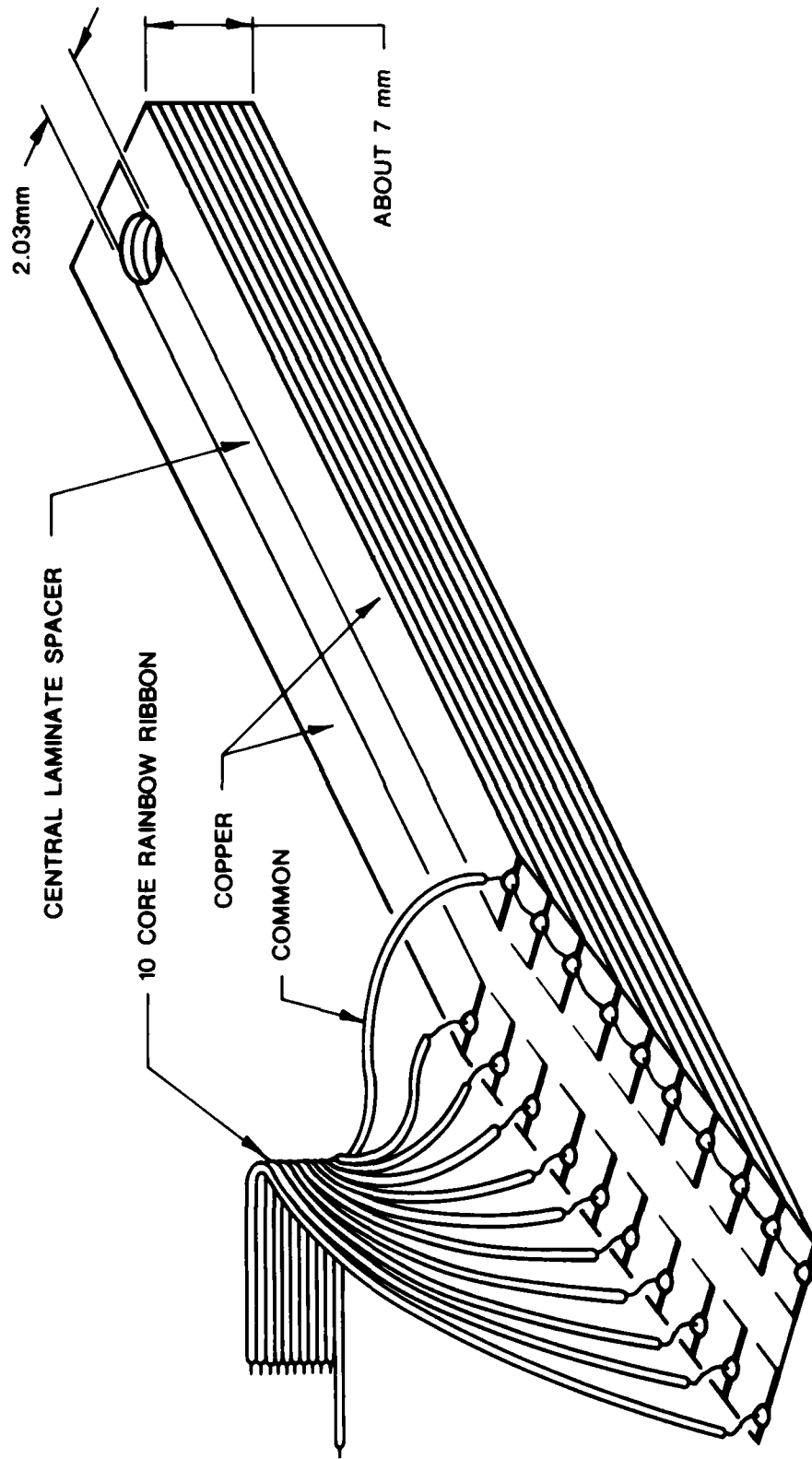
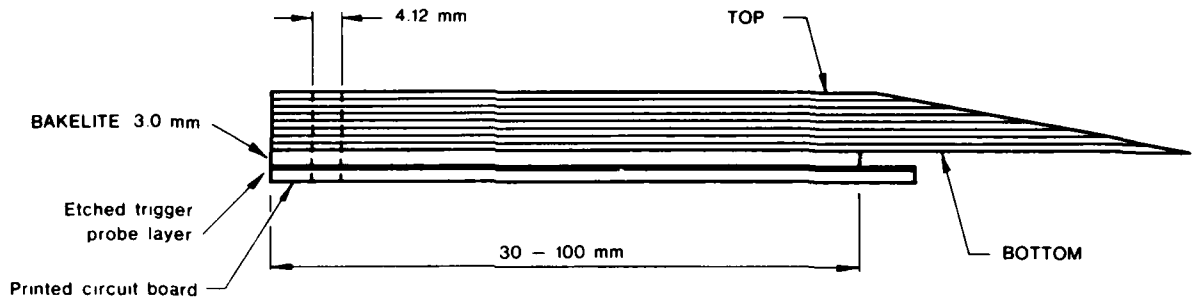

FIG. 1 - Illustration of Multilayer Board with Circuit Layers Wired for Connection to Event Pulse Circuit
(not to scale)

SIDE VIEW



(a) For charges to be initiated by Lead Azide fusehead (electrical leads are not shown).

SIDE VIEW

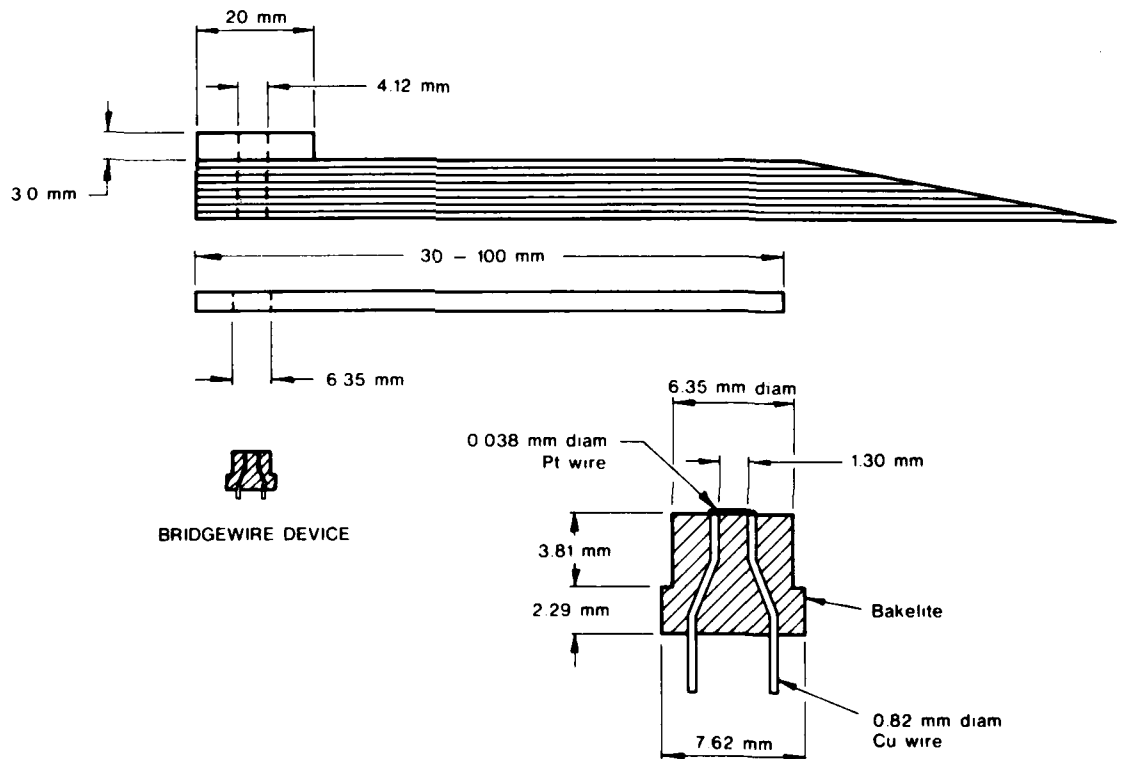

(b) For charges to be initiated by hot wire (electrical leads are not shown). The bridgewire device is shown enlarged in inset.

FIG. 2 - Configuration of Multilayer Boards for Explosive Filling

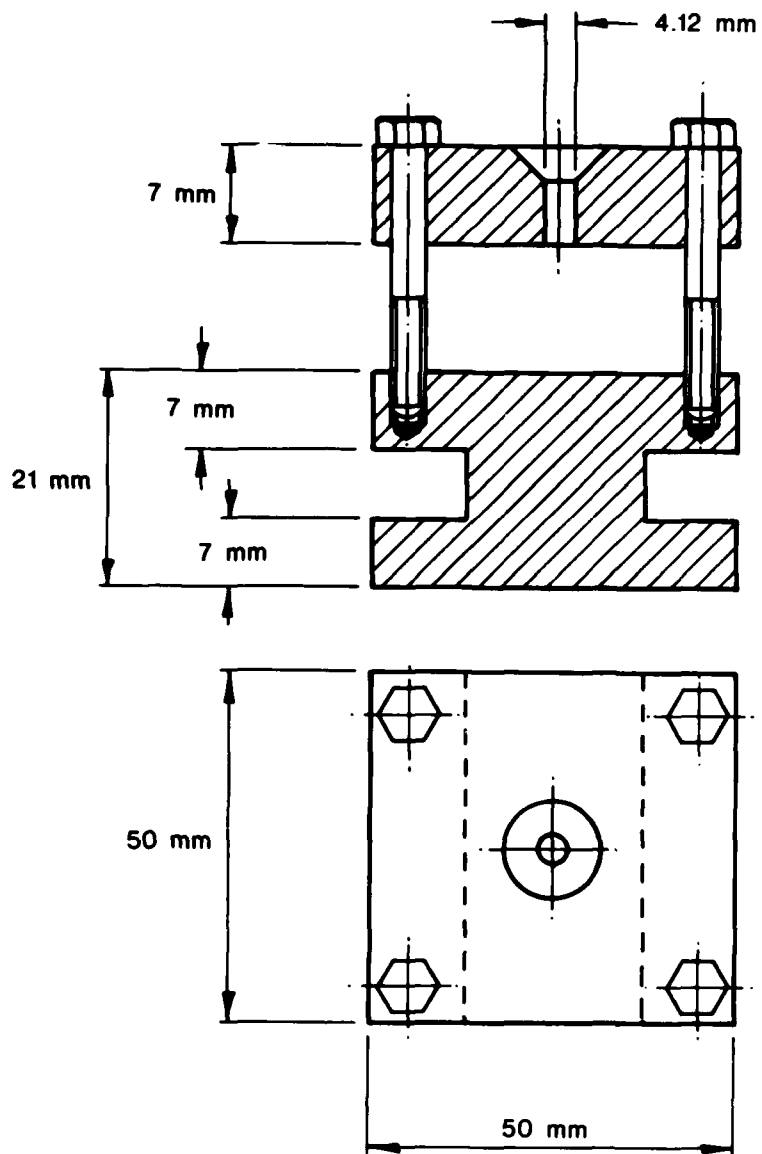

FIG. 3 - Pressing Mould for Explosive Filling of Multilayer Board.

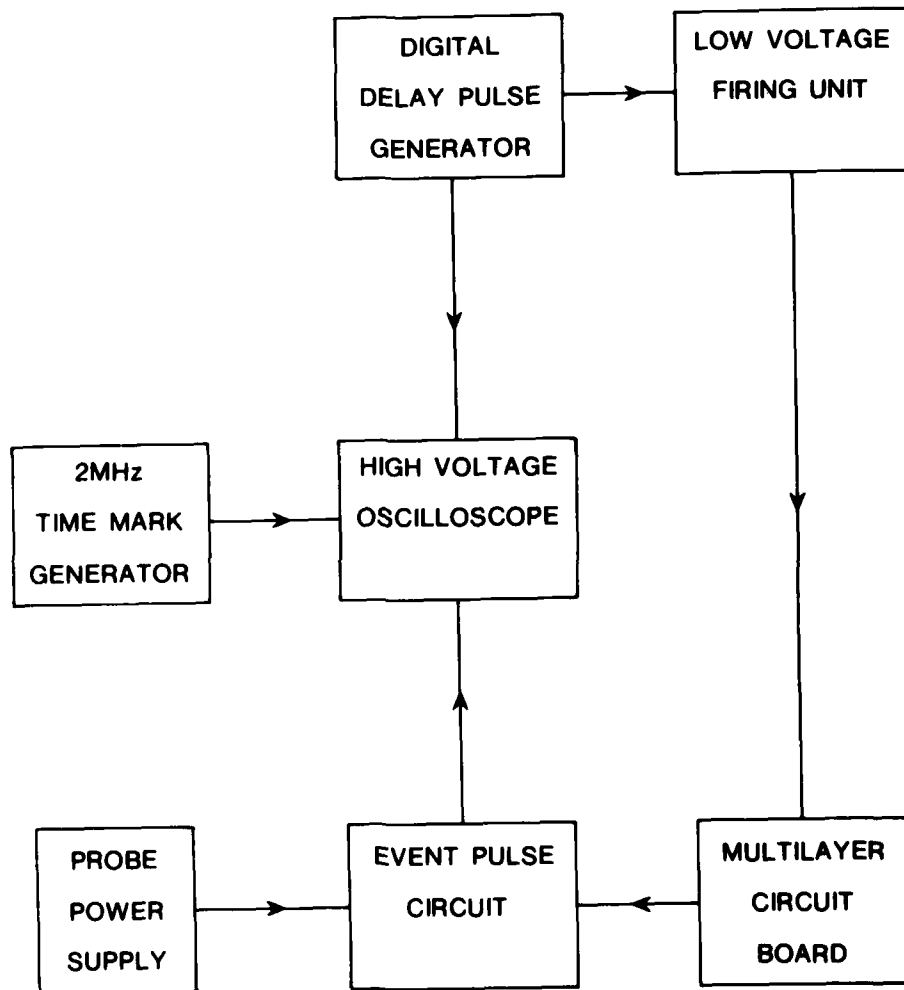

FIG. 4 - Block Diagram of Firing and Recording Instrumentation for Multilayer Board.

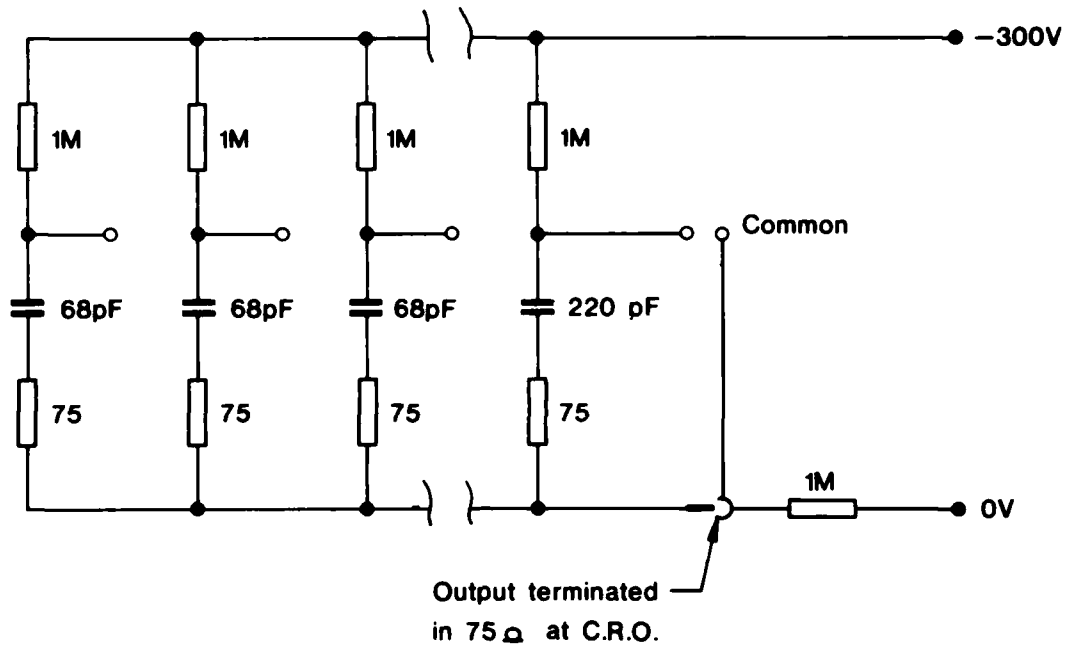
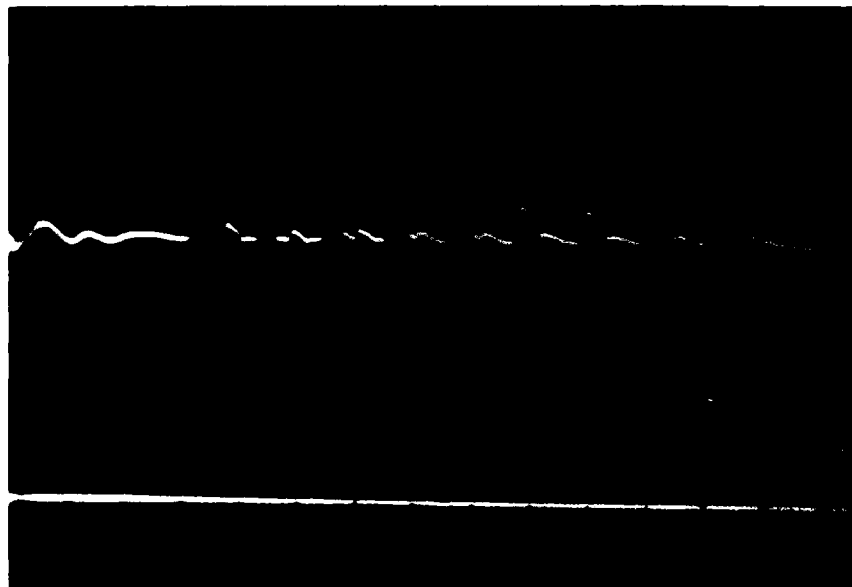

FIG. 5 - Event Pulse Circuit for Multilayer Board.



Timing
pulses $0.2 \mu s$

FIG. 6 - Typical CRO Trace of Event Pulses for Service Lead Azide Initiated by Fusehead.

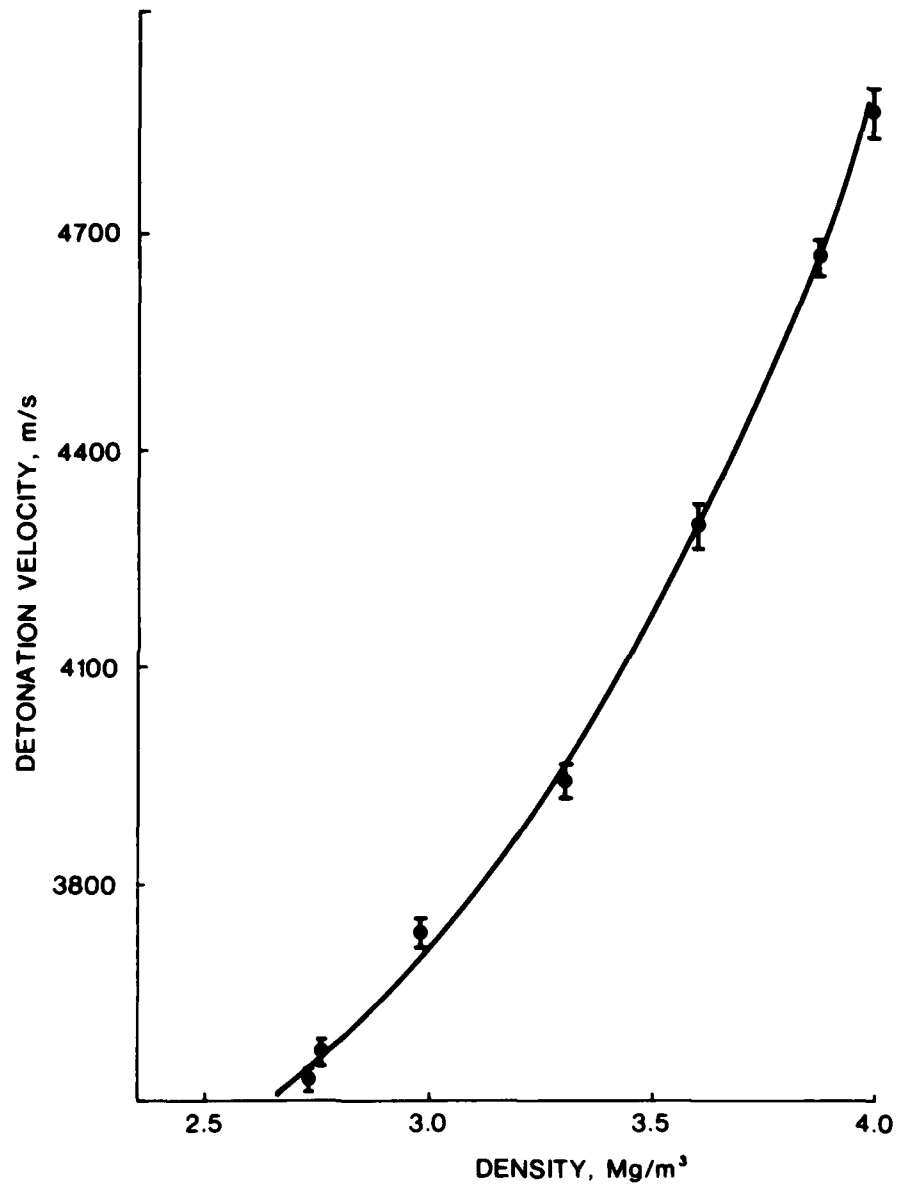
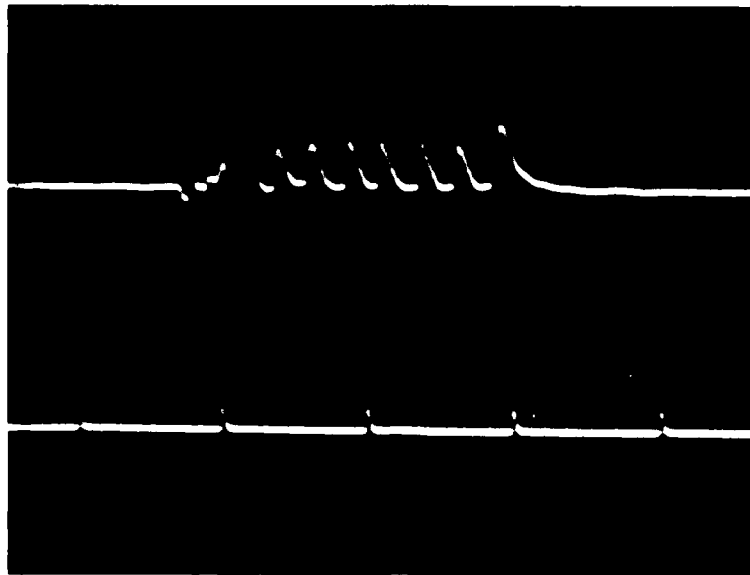
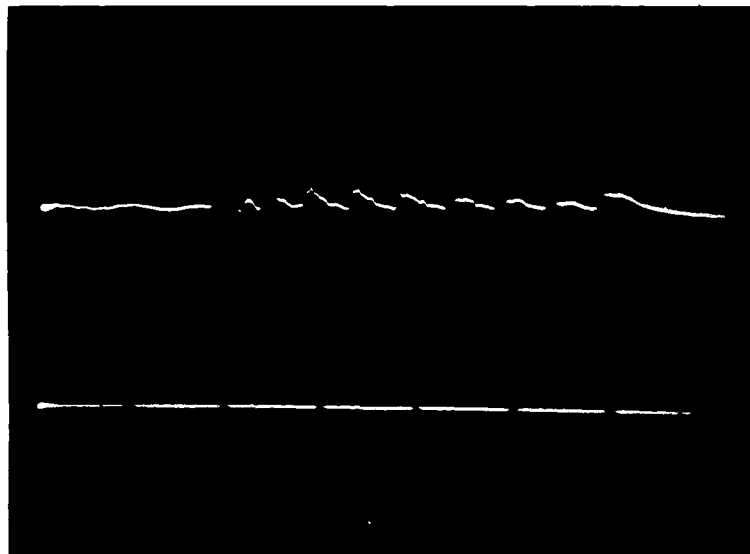

FIG. 7 - Plot of Detonation Velocity Versus Density for Pressed Service Lead Azide.



Timing
pulses $0.5 \mu s$

FIG. 8 - Typical CRO Trace of Event Pulses for Hot Wire Initiated
Charges: Mercuric 5-nitrotetrazole.



Timing
pulses $0.2 \mu s$

FIG. 9 - Typical CRO Trace of Event Pulses for Tetryl Initiated
by Lead Azide.

(MRL-R-815)

DISTRIBUTION LIST

MATERIALS RESEARCH LABORATORIES

Chief Superintendent
Superintendent, Ordnance Research and Development
Dr. B.W. Thorpe
Dr. R.J. Spear
Mr. J.R. Bentley
Mr. M.G. Wolfson
Library
Librarian, Materials Testing Laboratories, N.S.W. Branch
(Through Officer-in-Charge)

DEPARTMENT OF DEFENCE

Chief Defence Scientist
Deputy Chief Defence Scientist
Controller, Projects and Analytical Studies
Superintendent, Science and Technology Department
Controller, Service Laboratories and Trials
Army Scientific Adviser
Air Force Scientific Adviser
Navy Scientific Adviser
Chief Superintendent, Aeronautical Research Laboratories
Chief Superintendent, Weapons Systems Research Laboratory,
Defence Research Centre
Chief Superintendent, Electronics Research Laboratory,
Defence Research Centre
Chief Superintendent, Advanced Engineering Laboratory,
Defence Research Centre
Superintendent, Trials Resources Laboratory,
Defence Research Centre
Senior Librarian, Defence Research Centre
Librarian, R.A.N. Research Laboratory
Officer-in-Charge, Document Exchange Centre, (17 copies)
Technical Reports Centre, Defence Central Library
Central Office, Directorate of Quality Assurance - Air Force
Deputy Director Scientific and Technical Intelligence
Head, Engineering Development Establishment
Librarian, Bridges Library, Royal Military College
Officer-in-Charge, Joint Tropical Trials and Research Establishment

DEPARTMENT OF PRODUCTIVITY

NASA Canberra Office
Head of Staff, British Defence Research and Supply
Staff (Aust.)

(MRL-R-815)

DISTRIBUTION LIST

(Continued)

OTHER FEDERAL AND STATE DEPARTMENTS AND INSTRUMENTALITIES

The Chief Librarian, Central Library, C.S.I.R.O.
Australian Atomic Energy Commission Research Establishment
The Librarian, National Measurement Laboratory
Chief, Division of Tribophysics, C.S.I.R.O.
Chief, Division of Mechanical Engineering, C.S.I.R.O.
Chief, Division of Chemical Technology, C.S.I.R.O.

MISCELLANEOUS - AUSTRALIA

Secretary, Department of Science, Woden, A.C.T.

MISCELLANEOUS - OVERSEAS

Defence Scientific & Technical Representative, Australian
High Commission, London, England
Assistant Director/Armour and Materials, Military Vehicles and
Engineering Establishment, Surrey, England
Reports Centre, Directorate of Materials Aviation, Kent, England
Library - Exchange Desk, National of Bureau of Standards,
Washington, U.S.A.
U.S. Army Standardization Representative, Canberra, A.C.T.
The Director Defence Scientific Information and Documentation
Centre, Delhi, India
Colonel B.C. Joshi, Military, Naval and Air Adviser, High
Commission of India, Red Hill, A.C.T.
Director, Defence Research Centre, Kuala Lumpur, Malaysia
Exchange Section, British Library, Lending Division, Yorkshire
England
Periodicals Recording Section, Science Reference Library, The
British Library, Holborn Branch, London, England
Library, Chemical Abstracts Service, Columbus, Ohio, U.S.A.
INSPEC: Acquisition Section, Institution of Electrical Engineers
Station House, Hitchin, Herts, England
Overseas Reports Section, Defence Research Information Centre,
Ministry of Defence, Orpington, Kent, England
Counsellor Defence Science, Embassy of Australia, Washington, U.S.A.
Engineering Societies Library, New York, U.S.A.
Director, British Scientific Instrument Research Association,
South Hill, Chislehurst, Kent, England
Director, Propellants, Explosives and Rocket Motor Establishment,
Waltham Abbey, Essex, England

(MRL-R-815)

DISTRIBUTION LIST

(Continued)

MISCELLANEOUS - OVERSEAS (Cont.)

Director, Royal Armament Research & Development Establishment
Fort Halstead, Sevenoaks, Kent, England
Science Information Division, Department of Scientific & Industrial
Research, Wellington, New Zealand
Director General, Defence Research Establishment Valcartier,
Courcellette, Canada

DATE
ILME
— 88