



DEPARTMENT OF DEFENCE
DEFENCE SCIENCE AND TECHNOLOGY ORGANISATION
WEAPONS SYSTEMS RESEARCH LABORATORY

DEFENCE RESEARCH CENTRE SALISBURY
SOUTH AUSTRALIA

TECHNICAL REPORT

WSRL-0233-TR ✓

THE DESIGN OF A PORTABLE ALL ARMS CALCULATOR (PAAC)

C.J.P. BENSTED

DTIC
ELECTE
MAY 24 1982
A

Approved for Public Release

AD A114792

DTIC FILE COPY

COPY No. 10

C Commonwealth of Australia
OCTOBER 1981

82 05 24 007

The official documents produced by the Laboratories of the Defence Research Centre Salisbury are issued in one of five categories: Reports, Technical Reports, Technical Memoranda, Manuals and Specifications. The purpose of the latter two categories is self-evident, with the other three categories being used for the following purposes:

- Reports : documents prepared for managerial purposes.
- Technical Reports : records of scientific and technical work of a permanent value intended for other scientists and technologists working in the field.
- Technical Memoranda : intended primarily for disseminating information within the DSTO. They are usually tentative in nature and reflect the personal views of the author.

UNCLASSIFIED

AR-002-635

DEPARTMENT OF DEFENCE

DEFENCE SCIENCE AND TECHNOLOGY ORGANISATION

WEAPONS SYSTEMS RESEARCH LABORATORY



TECHNICAL REPORT

WSRL-0233-TR

THE DESIGN OF A PORTABLE ALL ARMS CALCULATOR (PAAC)

C.J.P. Bensted

S U M M A R Y

A microprocessor based calculator is described which has been designed to provide assistance in determining aiming coordinates for Mortar fire control. However by changing the keyboard overlay and the software the calculator can be used for a variety of applications including Artillery and Armour fire control.



POSTAL ADDRESS: Chief Superintendent, Weapons Systems Research Laboratory,
Box 2151, GPO, Adelaide, South Australia, 5001.

UNCLASSIFIED

TABLE OF CONTENTS

	Page
1. INTRODUCTION	1
2. GENERAL DESCRIPTION	1
3. MICROPROCESSOR CIRCUIT	2
4. DISPLAY UNIT INTERFACE	2
5. KEYBOARD INTERFACE	3
6. MATHEMATICAL PROCESSOR INTERFACE	4
7. POWER SUPPLY	4
8. CONSTRUCTION	4
9. CONCLUSION	5
10. ACKNOWLEDGEMENTS	5
REFERENCES	6
GLOSSARY OF TERMS	7

LIST OF FIGURES

1. The Portable All Arms Calculator
2. Calculator and Demonstration Carrying Case
3. Internal Construction of the Calculator
4. Block Diagram
5. Microprocessor Circuit and Mathematical Processor Interface
6. Random Access Memory and Low Battery Circuit
7. Program Memory Circuit
8. Display and Keyboard Interface Circuits
9. Wiring Diagram



Accession For	
NTIS GRA&I	<input checked="" type="checkbox"/>
DTIC TAB	<input type="checkbox"/>
Unannounced	<input type="checkbox"/>
Justification	
By	
Distribution/	
Availability Codes	
Avail and/or	
Dist. Statement	

A

1. INTRODUCTION

In 1977, Army Office issued Army Staff Requirement (ASR) 48.3 which described the Infantry's need for a calculator to carry out technical fire control tasks. The Weapons Systems Research Laboratory (WSRL) and the Electronics Research Laboratory (ERL) of the Defence Science and Technology Organisation (DSTO) jointly produced a small hand held calculator code named ELMOR (Elevation of MORTar), to demonstrate the feasibility of developing such a device in Australia. Whilst ELMOR provided an indication of the capability of small special purpose calculators using the technology existing at that time, it was clear that with assistance from the Army, a calculator with more widespread fire control application could be designed.

Consequently, a Portable All Arms Calculator (PAAC) was considered as a technical objective with users being primarily the Infantry, Artillery and Armour. In view of the recent experience gained by the DSTO in preparing ELMOR for Army evaluation, it was decided that the mortar application of PAAC should be considered before the others. Having assessed ELMOR in the field and at the Infantry Centre, the Army was able to provide the DSTO with a number of recommendations that might be considered in the further development of a fire control calculator.

In early 1980, the DSTO decided to produce advanced demonstration models of PAAC which could be evaluated by the Army in order to assess the viability of an All Arms approach. This report describes the design of the advanced demonstration model. The mortar fire control software was developed by staff from Ballistic Studies Group, WSRL.

2. GENERAL DESCRIPTION

The calculator is a hand held unit about the size of a medium sized book. It has a liquid crystal display (LCD) on which thirty two alpha-numeric characters, arranged in two rows of sixteen characters, can be displayed. It also has a keyboard consisting of forty keys placed in an 8 x 5 matrix arrangement. Photographs of the completed calculator are shown in figures 1, 2 and 3.

The unit is battery powered using rechargeable nickel-cadmium batteries but provision has been made for the use of external power if required. The batteries can be changed while the calculator is in use. Low power standby batteries are provided which retain, during main battery changeover, all data previously entered into volatile memory. These standby batteries are trickle charged from the main batteries which have to be recharged using an external charger. Provision has been made for warning the operator when the main battery voltage has reached a lower limit by flashing the display during the last approximately thirty minutes of the life of the batteries.

An additional feature of the calculator is the provision of a serial interface so that the calculator can be connected to, and communicate with, external computing or display equipment. This interface uses the internationally recognised RS232C communication protocol.

The circuit design of the calculator uses low power CMOS components wherever possible. No suitable CMOS microprocessor was available when this circuit was developed. However, it was known that a microprocessor manufacturer was intending to market in the near future a CMOS processor, known as the NSC800 (see Reference 1), which would use the same instruction set as the NMOS Z80 processor which was readily available. The design of the calculator was therefore based on the Z80 processor and software has been written using its instruction set. This design is therefore an interim design and it is

anticipated that any further models of this calculator, that may be produced, would be redesigned to use the NSC800 processor and its associated interface devices.

3. MICROPROCESSOR CIRCUIT

The calculator is based on a Z80A microprocessor driven by a 3 MHz clock and a block diagram of the unit is shown in figure 4. The microprocessor has been provided with thirty-two kilobytes of erasable programmable read only memory (EPROM) for program storage and four kilobytes of read/write memory or random access memory (RAM) for data storage. The EPROM occupies the address space 0000 to 7FFF, using the hexadecimal notation, and the RAM is at F000 to FFFF.

Two interface devices are connected to the microprocessor namely an 8255A parallel peripheral interface (PPI) unit, for driving the 32 character display and reading the 40 key keyboard, and an 8251A serial interface unit to allow communication between the microprocessor and external equipment. The microprocessor also has a second PPI unit for connection to an MM57109 mathematical processor integrated circuit (IC). This processor was included to perform the mathematical computations required in determining aiming coordinates. This computation can be done much faster in software but this processor was included in the design to simplify the initial task of writing software for mortar fire control. The mathematical processor and the parallel port unit will be removed when the appropriate software package performing the same function has been written.

The circuits shown in figures 5, 6 and 7 which were used to connect the microprocessor to its memory and interface devices are standard and examples are readily found in manufacturers literature(ref.2,3) so no further description will be given here. The 8255A PPI interface circuits are described in detail in subsequent sections. The 8251A device can be used as an RS232C interface. However, no buffering of the device input or output signals has been provided. It is anticipated that any buffering required would be provided by the host system to which the calculator is connected. Transmit and receive clock signals for this interface will also be provided by the host equipment.

4. DISPLAY UNIT INTERFACE

A circuit diagram of the display unit interface and the keyboard interface is shown in figure 8. The display interface is controlled by Port A and the upper half of Port C of an 8255A PPI unit. Port A is used to output data in the form of ASCII characters to the display RAM (IC5 and IC9).

Port C bit 7 is used to control the display unit. When PC7 is a '1' the display unit is disabled and an updated message can be written to the display RAM. When PC7 is a '0' the display unit will read the RAM via the address lines AA0 to AA4 inclusive and use its clock signal (ϕ_c) to output the contents of each memory location onto the address lines of the character generator circuit (IC1). The output of the character generator in the form of row and column information is then read by the display circuit using the S1 to S3 and the DC1 to DC5 lines.

Port C bit 6 is used by the microprocessor to reset the counter (IC6) to zero at the start of the sequence which writes a new message to the display RAM. The counter is used to provide an incrementing address to the display RAM via the tri-state buffer (IC2) which is enabled by PC7.

Port C bit 5 is used to clock the counter (IC6) by one count thereby

incrementing the address to the display RAM. Port C bit 4 is used to write the character, which has previously been set up on the Port A lines, into the display RAM.

The sequence of events which occur when the display sub-routine is accessed by the microprocessor can be summarised as follows:

- (a) Establish a '1' on the PC7 line, ie, disable the display
- (b) Zero the display counter (IC6) by sending a pulse on the PC6 line
- (c) Establish a character on the Port A lines
- (d) Write the character into the display RAM (IC5 and IC9) at the address set up by the counter (IC6) by sending a 50 microsecond pulse to the PC4 line. (This pulse must have a minimum duration of 50 microseconds to ensure that a clock signal (ϕ_c) occurs during the writing period).
- (e) Check to see if 32 characters have been sent and if so jump to step 'h'
- (f) If not, increment the counter (IC6) by sending a pulse on the PC5 line
- (g) Jump to step 'c' to write next character
- (h) Establish a '0' on PC7 to allow the display unit to read the display RAM and exit the subroutine.

When the display unit is enabled, by the PC7 line being set to a '0' it will continually read the display RAM at a rate determined by its internal clock signals so that the 32 characters are continuously displayed.

5. KEYBOARD INTERFACE

The keyboard consists of a matrix of 40 normally open switches which can be pressed by the operator. These switches are set up in the form of 5 columns of 8 switches each. Port B lines 0 to 4 are used by the microprocessor to interrogate each column of switches in turn. The lower half of Port C is used to read the switches in the appropriate column to ascertain which switch has been pressed.

ICs 3 and 7 are wired to provide an 8 bit priority encoder the output of which, in binary coded decimal format, is read via the gates in IC11 by the lower half of Port C.

The 'keyboard read' subroutine establishes a '0' on the PBO line and '1's on the PB1 to PB4 lines thereby interrogating the first column. The PC0 to PC3 lines are then read by the microprocessor to see if a switch has been pressed in that column. If it has then the processor exits the subroutine taking with it the identification of the switch which has been pressed. If no switch has been pressed in that column then PBO is set to a '1' and PB1 is set to a '0' and the next column of switches is interrogated. This process is repeated for all five columns if necessary. The processor will exit the subroutine as soon as it finds a switch pressed. In this way there is no confusion if two switches are pressed at the same time as the processor will only 'see' one of them.

6. MATHEMATICAL PROCESSOR INTERFACE

The mathematical processor was included in the calculator design to provide the mathematical computation functions required. Also it eliminated the need for software to be written to provide the same complex mathematical functions. However it performs these functions much slower than would an equivalent software package. It is intended that this processor and its interface will no longer be used when equivalent software has been developed.

The circuit of the mathematical processor interface is shown in figure 5 and comprises ICs 3, 4, 5, 6 and 8. An 8255A (IC4) is used to interface the microprocessor to the mathematical processor (IC5). A triple inverter oscillator circuit (IC3) is used to provide a 400 kHz clock signal for IC5 which also requires a negative voltage supply (ICs 12, 13, 14). Port A is used to provide instruction codes to the processor and Port B is used as a bi-directional binary coded decimal (BCD) data path. IC6 is used as a voltage level translator for the 'power on reset' and 'hold' signals. IC8 is a dual flip-flop used to temporarily store the 'branch' and 'digit address strobe' signals developed by the mathematical processor so that the central processor can 'read' them at a convenient time.

The function of, and the programming for, the mathematical processor is quite complex and it is not practicable to further describe it in this note. Complete details of the operation of the mathematical processor are given in reference 4.

7. POWER SUPPLY

The calculator is powered by four 'D' size nickel-cadmium batteries which provide the nominal 5 volts supply required by the semiconductor devices. These batteries are rechargeable and have a capacity of four ampere-hours which is sufficient for the calculator to be used continuously for up to eight hours. This duration will be extended to at least ten hours when the mathematical processor device and its associated interface circuit is removed and replaced by a software package performing the same function.

The display unit also requires a minus 5 volt supply and this is provided by ICs 12, 13 and 14 (figure 5). Three devices are required, connected in parallel, to supply the necessary current.

Provision has been made for operating the calculator using external power, for which a socket has been provided (figure 9), and for detecting low battery volts. The low battery voltage circuit is shown as part of the RAM circuit diagram (figure 6). The voltage comparator (IC8) compares a voltage, which is derived from a potential divider connected across the battery supply, with a reference voltage developed by IC7. When the voltage is less than the reference voltage, the voltage comparator triggers the timer unit IC1 which interrupts the processor to indicate low battery voltage. The timer can then interrupt the processor after a fixed time interval to remind the operator that the battery volts are still low. The battery voltage at which this circuit trips is set to indicate that there is approximately thirty minutes battery life remaining after the first interrupt occurs.

8. CONSTRUCTION

The calculator is fabricated from a polypropylene compound which is similar to the compounds that might be used in production using injection moulding techniques. The case produced is about three times as light in weight as an equivalent case manufactured from aluminium. In this instance the case was

milled from a solid piece of the polypropylene compound as only a few cases were required.

Separate compartments are provided for the electronic cards, the main batteries and the standby batteries. Access to the battery compartments is provided by means of recessed aluminium covers which are screwed in place but which can be removed without the aid of special tools. A recessed push-button switch is provided to switch the calculator ON and OFF and two connectors (military specification) are fitted, one to allow connection to an external power source, and the other for the serial data interface.

The thirty-two character LCD display unit is fitted at the top of the front panel of the calculator and covered with an anti-glare filter. This display and filter assembly is sealed into the case to prevent the entry of moisture.

The keyboard, which is below the display and occupies the remaining front panel space, consists of two five by four flexible membrane switch matrices connected to form an eight by five keyboard. A clear plastic overlay on which the key functions are annotated, covers the keyboard and is held in place by means of a black anodised aluminium grill which physically defines each key position. The keyboard is also sealed against the entry of moisture. The overlay and the grill which holds it in place is easily removed to allow the fitting of an alternative overlay so that the keys can be assigned different functions for different applications.

The electronic cards and the display module are fitted into the calculator from the rear. The electronic cards plug into each other and the program memory card (figure 7) is removable to allow for software changes for different applications of the calculator. The removable back cover has a gasket which seals the calculator against the entry of moisture.

The calculator including batteries weighs approximately two kilograms.

9. CONCLUSION

The calculator described in this report is an advanced demonstration model which could go into quantity production without much modification. However it is heavier than one would wish and a longer battery life of at least 20 hours would be most desirable. It is known that lower power components will shortly become available which will allow the weight to be reduced and the battery life extended. This improvement in performance can be achieved with a minimum of redesign to either the circuit or the software as it is anticipated that the lower powered microprocessor will use the same instruction set.

10. ACKNOWLEDGEMENTS

The author wishes to acknowledge the assistance of Mr S.G. Johnson who coordinated the project and was responsible for liaison with the Army Office. He also wishes to acknowledge the considerable assistance given in the mechanical design and production of the calculator by Mr A.D. Hind and Mr R.L. Thornton who were also responsible for the procurement of components, production of printed circuits and assembly and testing. The assistance of Mr A.I. Ware, who was responsible for the production of the case and battery fittings is much appreciated.

REFERENCES

No.	Author	Title
1	-	NSC800 Microprocessor Family Handbook 1980 National Semiconductor Corporation
2	-	MCS-80 User's Manual 1977 INTEL Corporation
3	-	Microcomputer Components Data Book February 1980 Zilog, Inc
4	-	MM 57109 MOS/LSI Number-Oriented Microprocessor 1977 National Semiconductor Corporation

GLOSSARY OF TERMS

ASCII	American National Standard Code for Information Interchange among data processing systems. Uses a coded character set consisting of 7 bit coded characters.
BINARY CODED DECIMAL (BCD)	A binary numbering system for coding decimal numbers in groups of four bits.
BIT	A circuit element which can only be stable in either of two states. One state is known as a '1' and the other as a '0'. A binary digit.
BYTE	A sequence of eight adjacent bits operated upon as a unit.
CMOS	A technique for integrated circuit manufacture known as 'complementary metal oxide silicon'.
EPROM	Erasable Programmable Read Only Memory. A data storage element, the contents of which can only be 'read' by the microprocessor and not altered by it. Data can only be altered by erasure followed by re-programming.
HARDWARE	The electronics and components of any computer or microprocessor which are hard physical objects.
HEXADECIMAL	A numbering system using the numbers 0 to 9 and the letters A to F to identify the sixteen numbers that four binary digits (bits) can have.
INTERRUPT	A hardware system which enables a program being executed by the processor to be stopped temporarily, while an alternative program is executed, and then resumed when the alternative task is completed.
NMOS	A technique for integrated circuit manufacture known as 'negative channel metal oxide silicon'.
PORT	An input or output route for transferring data or information to or from a system.
PPI	Parallel Peripheral Interface. A name given by one manufacturer to an integrated circuit used to 'input' or 'output' data to or from a microprocessor system.
PRIORITY ENCODER	A circuit which encodes a digital signal appearing on one of several lines into a parallel binary word, giving priority to that signal which first appears on these lines.
RAM	Random Access Memory A data storage element, the contents of which can be 'read' or altered by the microprocessor by choosing an address randomly.

RS232C

A specification for an internationally recognised method of serial data communication between digital systems.

SOFTWARE

A set of instructions for the operation of a computing system which are changeable for different applications of that system.

TRI-STATE

A circuit element which has the characteristic that it can either be a high level or a low level or it can present a high resistance to its output line effectively rendering that line open-circuit.

USART

Universal Synchronous Asynchronous Receiver Transmitter. An integrated circuit designed for use in serial digital data communication systems.



Figure 1. The Portable All Arms Calculator



Figure 2. Calculator and Demonstration Carrying Case

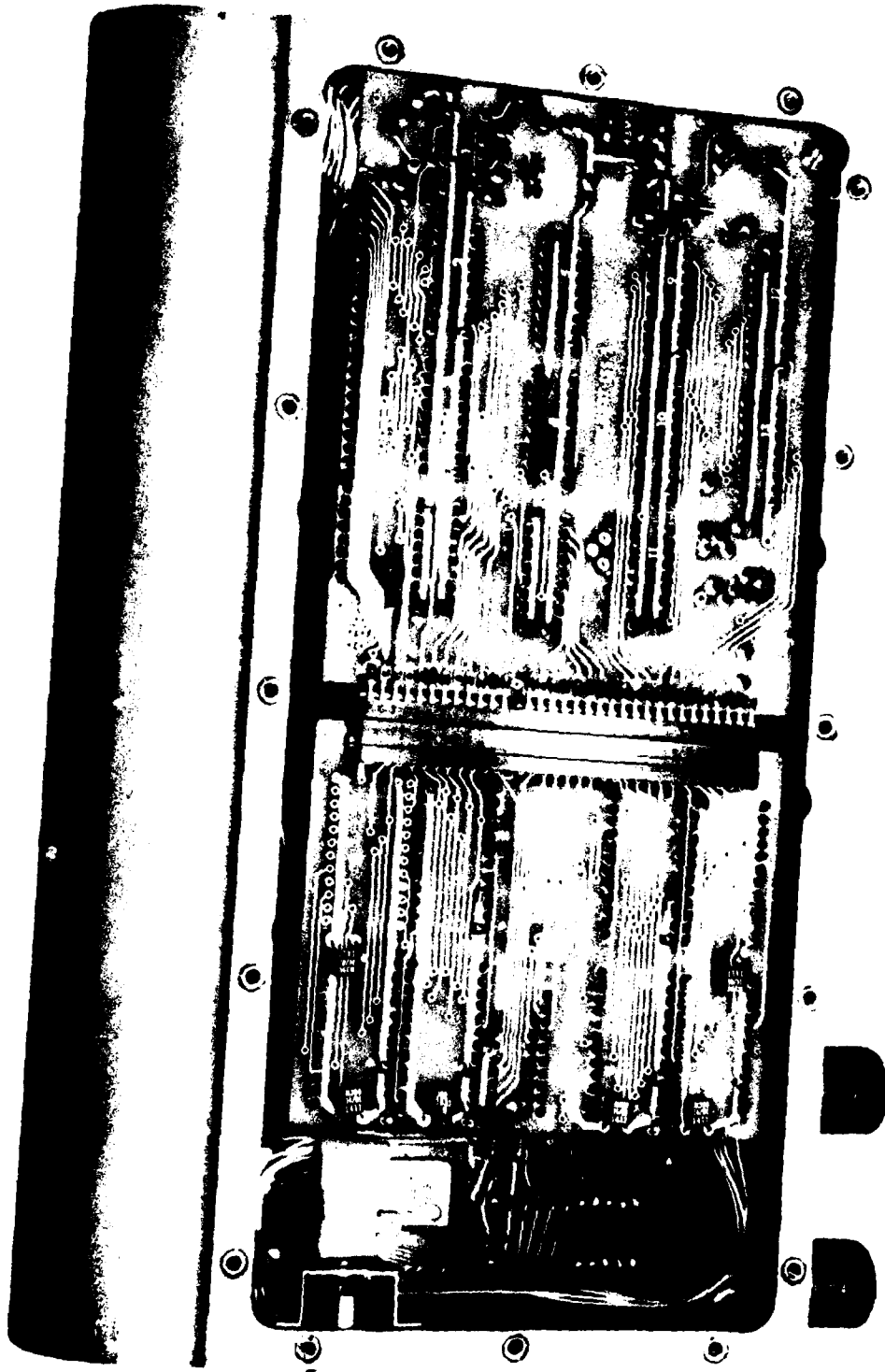

Figure 3. Internal Construction of the Calculator

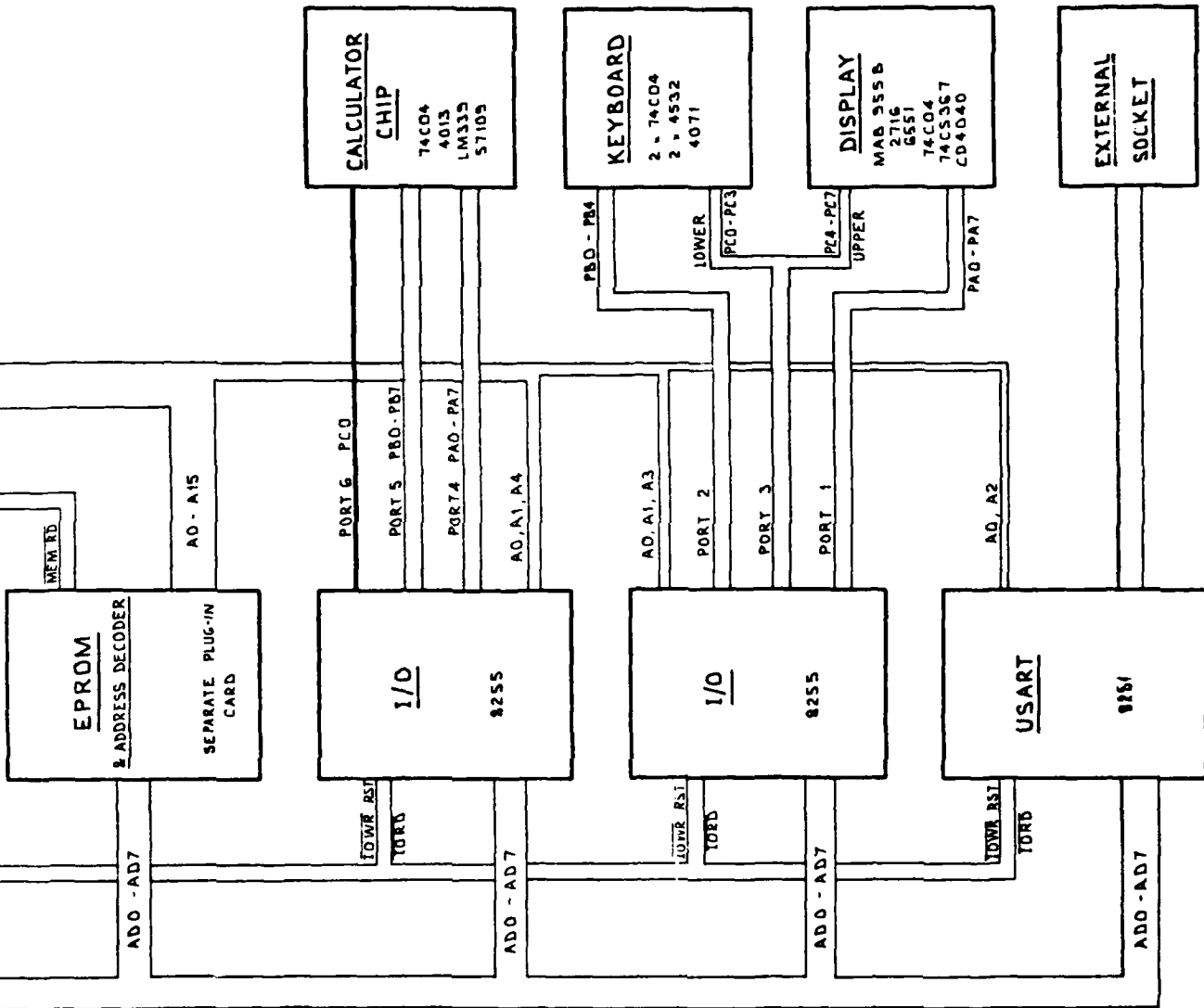

Figure 4. Block Diagram

2

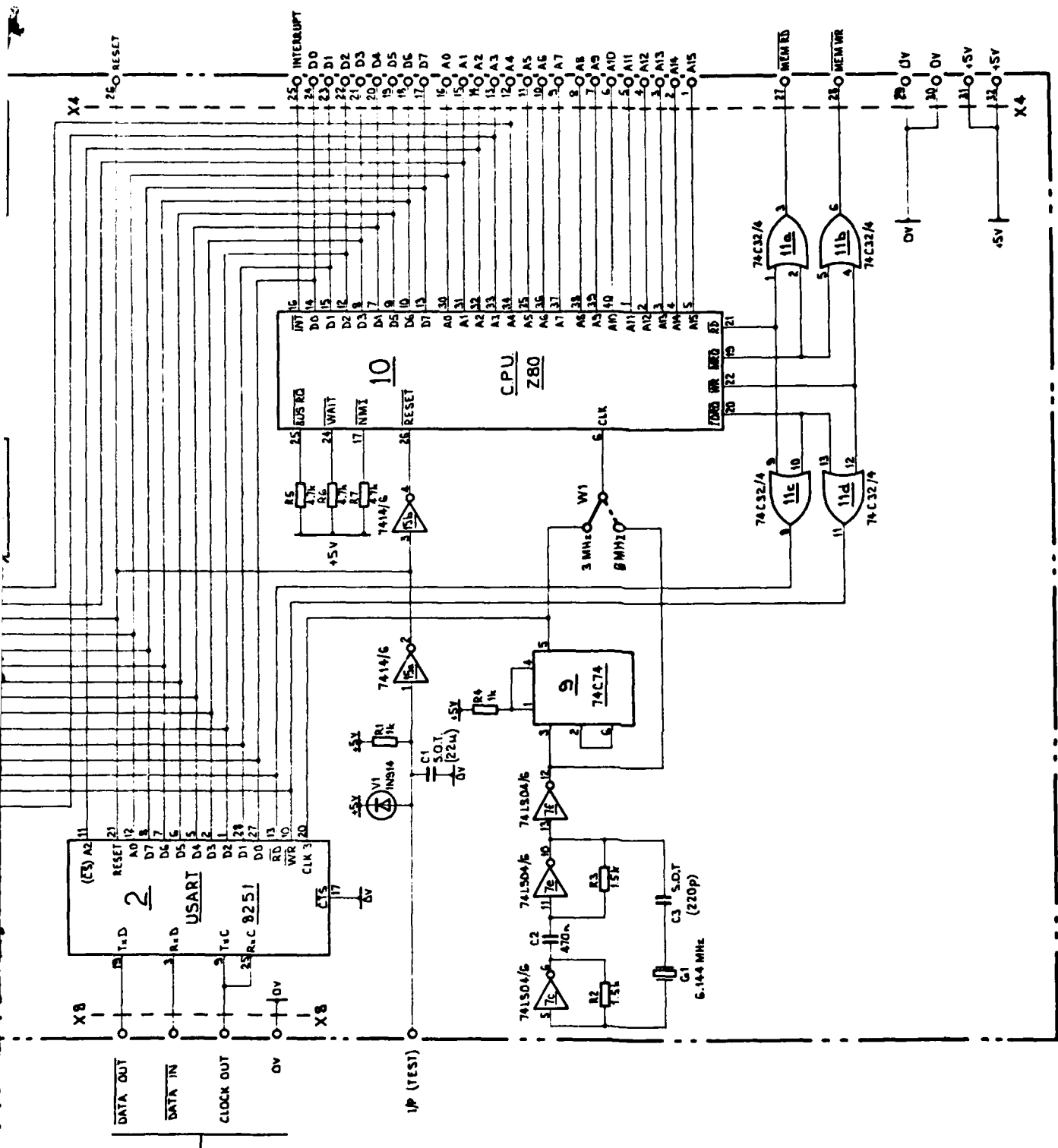
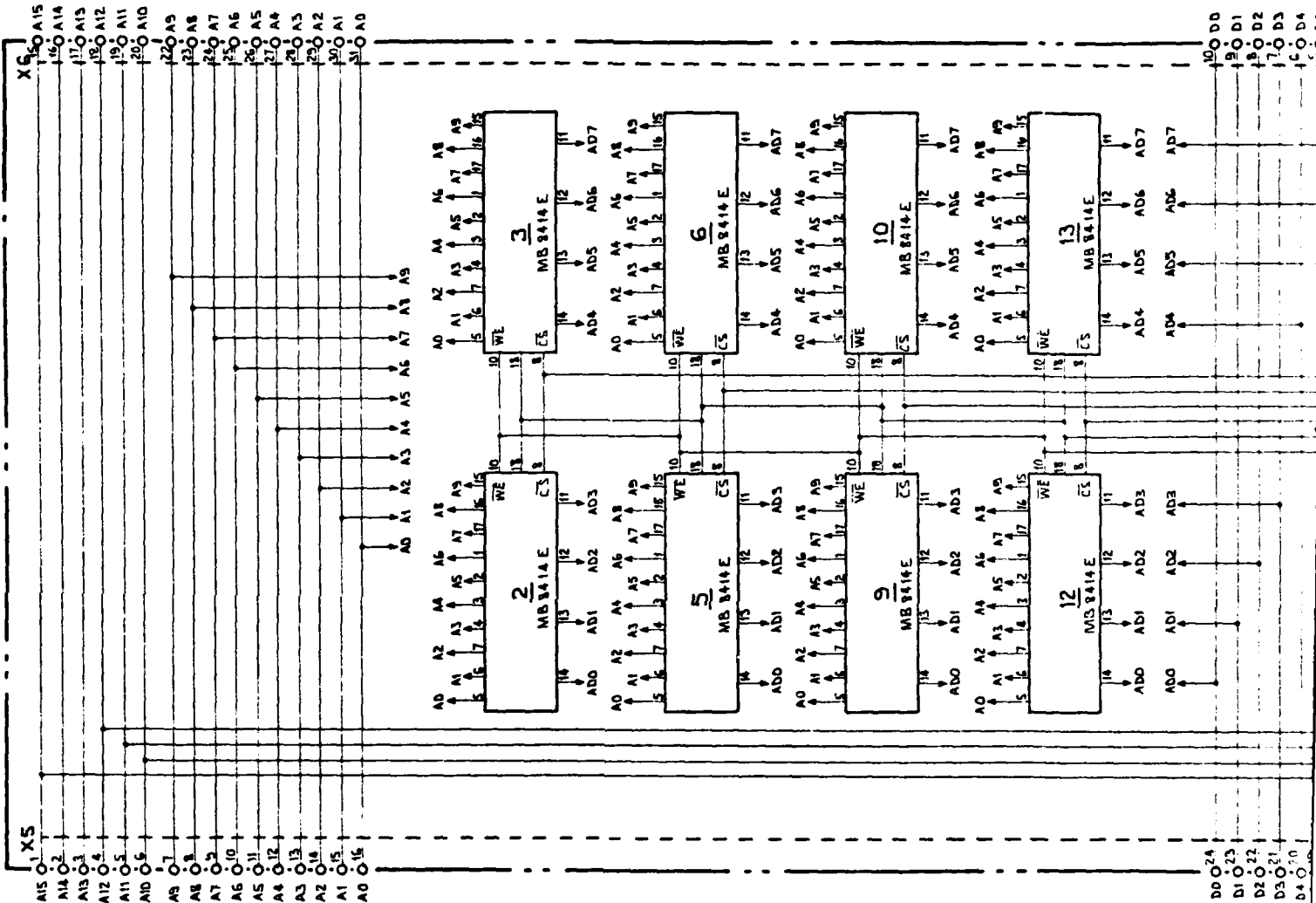

Figure 5. Microprocessor Circuit and Mathematical Processor Interface

DESCRIPTION	NO. OF PINS	+5V	0V	-5V	PKGE
RPI	40	25	7		RTL
USART	28	26	4		DIL
HEX INVERTER-BUFFER	14	14	7		DIL
FLIP FLOP	14	14	7		DIL
FLIP FLOP	14	14	7		DIL
CPU	40	11	25		DIL
QUAD 2 I/P OR	14	14	7		DIL
NEGATIVE INVERTER	8	8	3		DIL
QUAD 2 I/P OR	14	14	7		DIL

2



REF N°	TYPE	DESCRIPTION
1	7556	TIMER
2,3,5,6,9,10,12,13	MB8414E	CMOS RAM
4	74LS00	QUAD 2-INPUT NAND
7	74LS138	3-TO-8 DECODER
8	LM555	COMPANATOR
11	4078	NOR

X5
 A15 0
 A14 0
 A13 0
 A12 0
 A11 0
 A10 0
 A9 0
 A8 0
 A7 0
 A6 0
 A5 0
 A4 0
 A3 0
 A2 0
 A1 0
 A0 0

D0 0
 D1 0
 D2 0
 D3 0
 D4 0
 D5 0
 D6 0
 D7 0
 D8 0
 D9 0
 D10 0
 D11 0
 D12 0
 D13 0
 D14 0
 D15 0

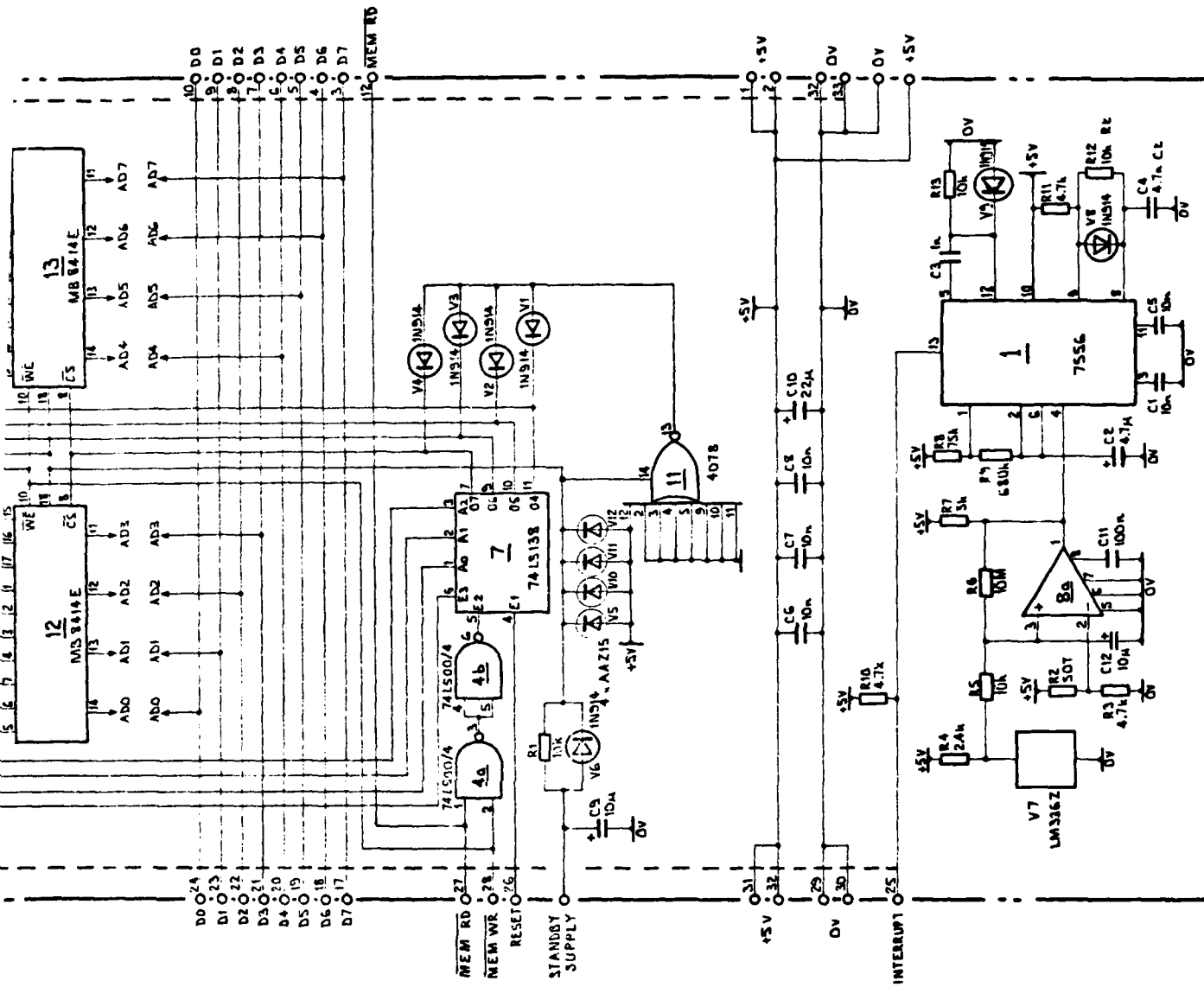
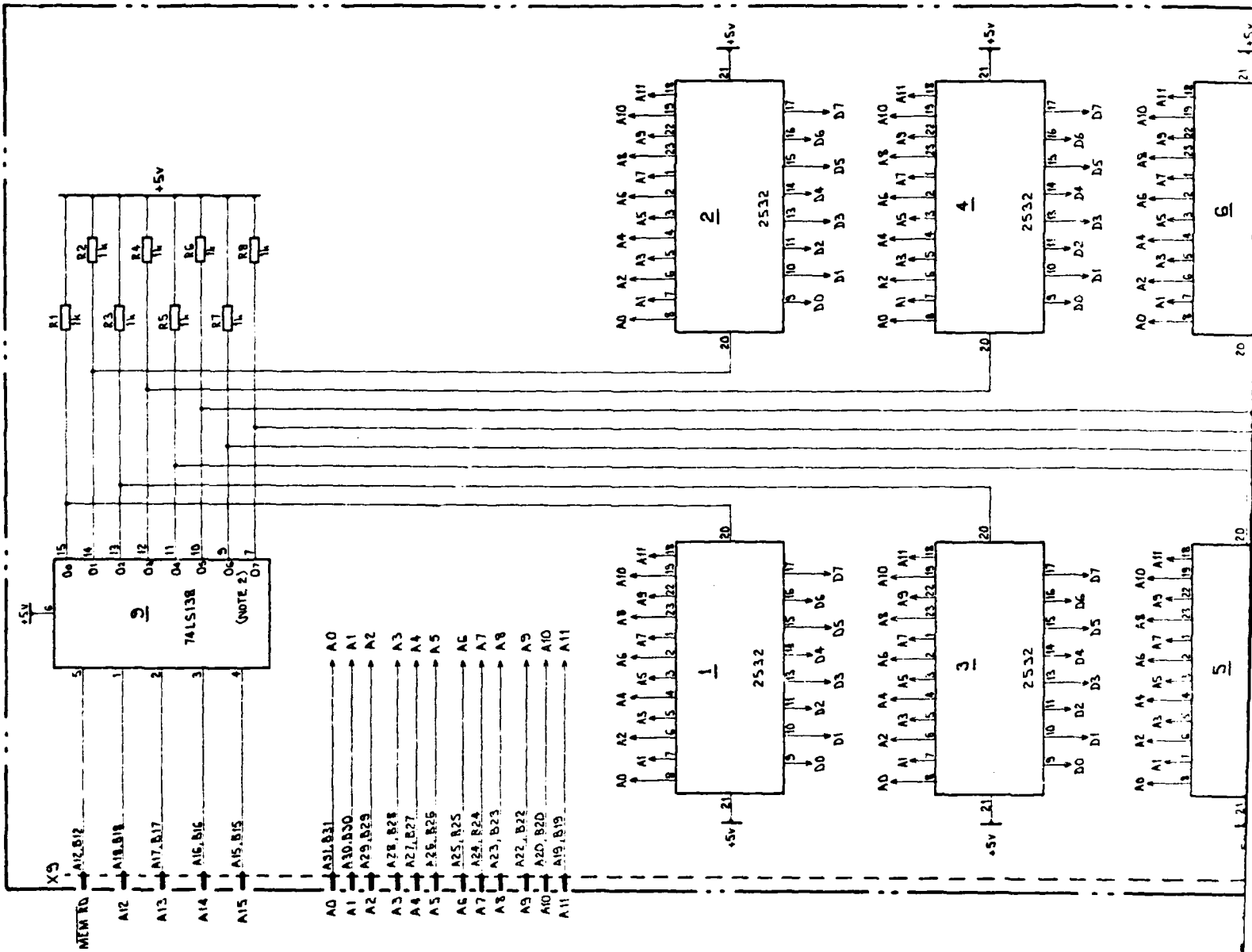

Figure 6. Random Access Memory and Low Battery Circuit

TYPE	DESCRIPTION	# OF PINS	+5V	0V	PKGE.
556	TIMER	14	14	7	DIL
8414E	CMOS RAM	16		9	DIL
74LS00	CMOS NAND	14	14	7	DIL
74LS138	CMOS DECODER	14	14	8	DIL
LM336Z	COMPARATOR	5	5	4	DIL
4078	NOR	14	14	7	DIL

2

WSRL-0233-TR
Figure 7



REF NO	TYPE	DESCRIPTION	NO OF PINS	5V	0V	0
1 to 8	2532	8K EPROM	24	24	12	12
9	74LS138	ADDRESS DECODER	16	16	8	8

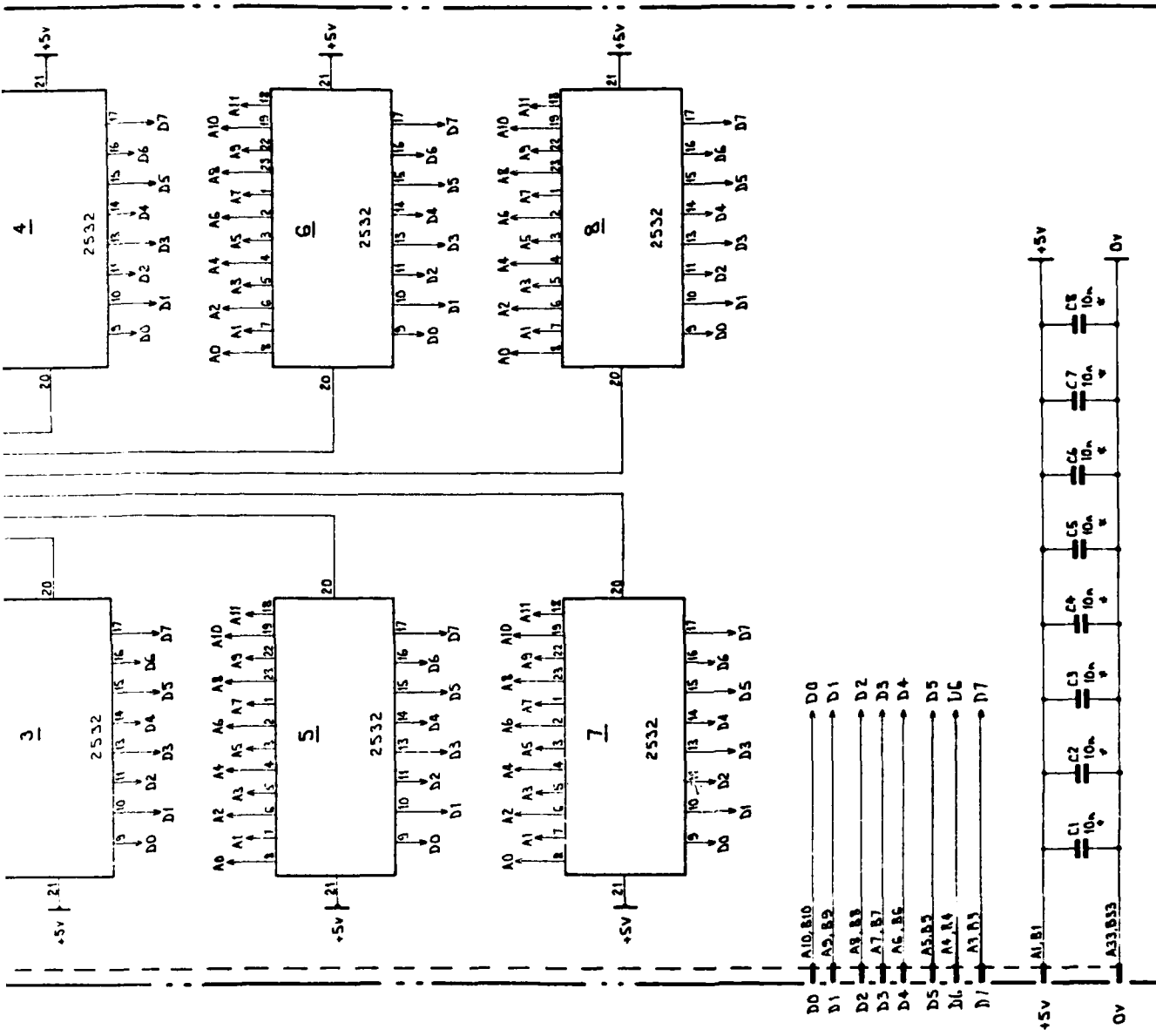
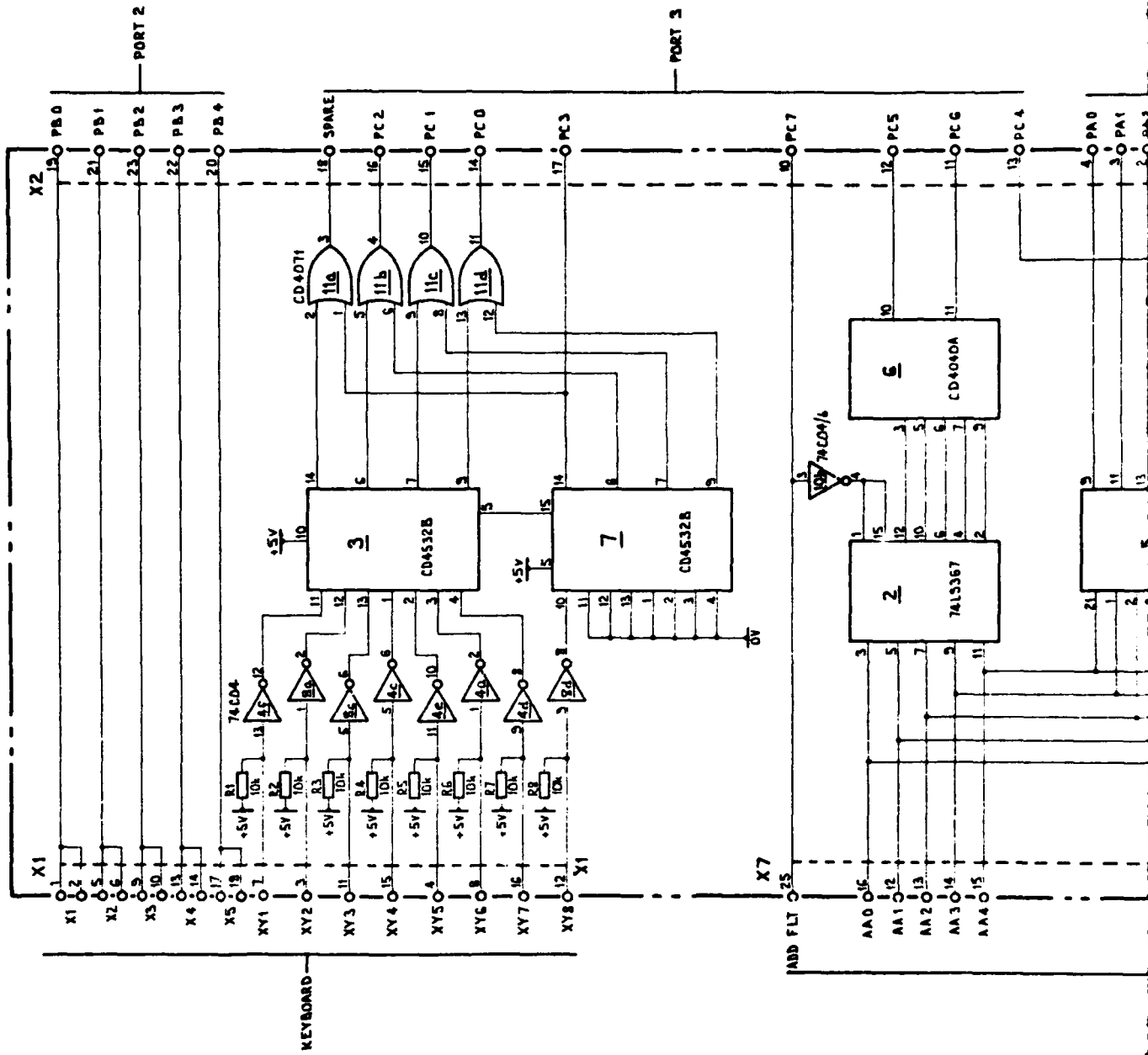

Figure 7. Program Memory Circuit

DESCRIPTION	NO OF PINS	+5V	0V	PKGE
EPROM	24	24	12	DIP
ADDRESS DECODER	16	16	8	DIP

2

NOTES: 1 WRITE ENABLE WE PULSE MUST BE $\geq 50\mu$ SECONDS



REF N°	TYPE	DESCRIPTION	N° OF PINS
1	CD4071	QUAD OR GATE	14
2	74LS367	TRI STATE BUFFER	16
3,7	CD4532B	PRIORITY ENCODER	16
4,8,10	74C04	HEX INVERTER	14
5,9	6551	CMOS RAM	22
6	CD4040A	COUNTER	16
11	CD4071	QUAD OR GATE	14

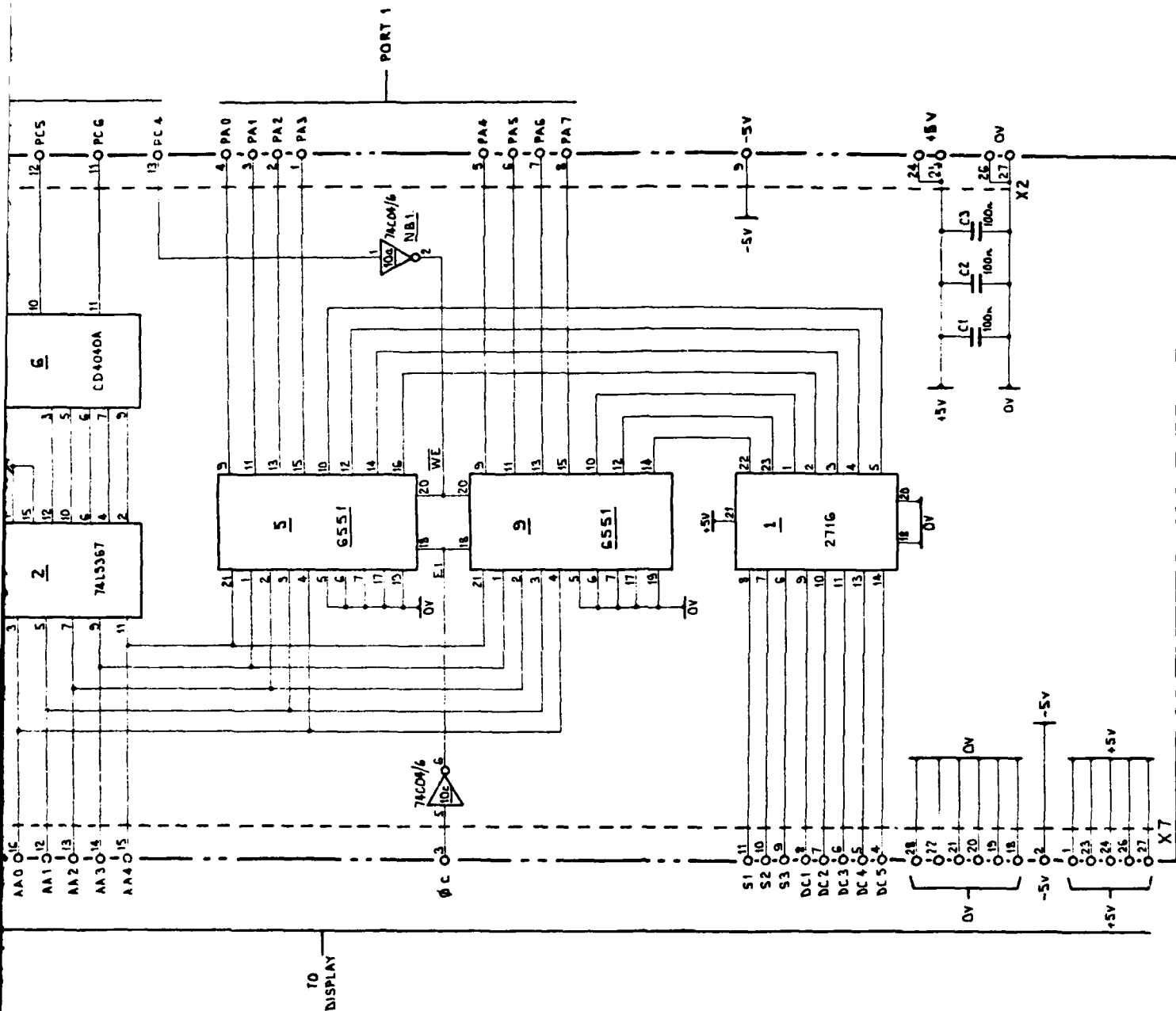

Figure 8. Display and Keyboard Interface Circuits

PE	DESCRIPTION	NO OF PINS	+5V	0V	-5V	PKCE
1	EPROM	24	2	1		D.L.
2	TRI-STATE 3-7 PEP	16	16	9		D.L.
3	PRIORITY ENCODER	16	16	8		D.L.
4	HEX INVERTER	14	14	7		D.L.
5	74LS367 PAM	22	22	8		D.L.
6	COUNTER	16	16	8		D.L.
7	3-STATE OR GATE	14	14	7		D.L.

2

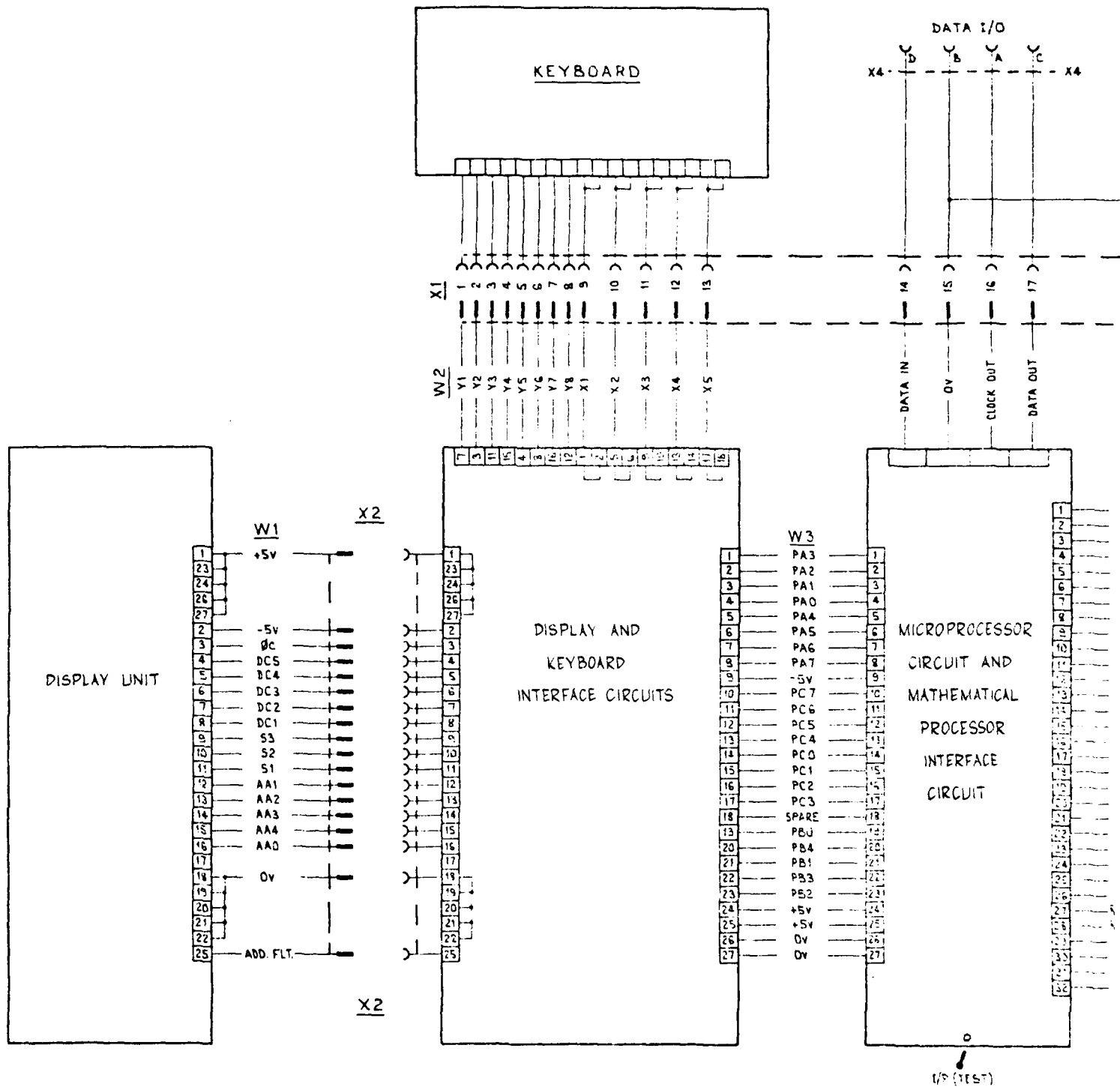
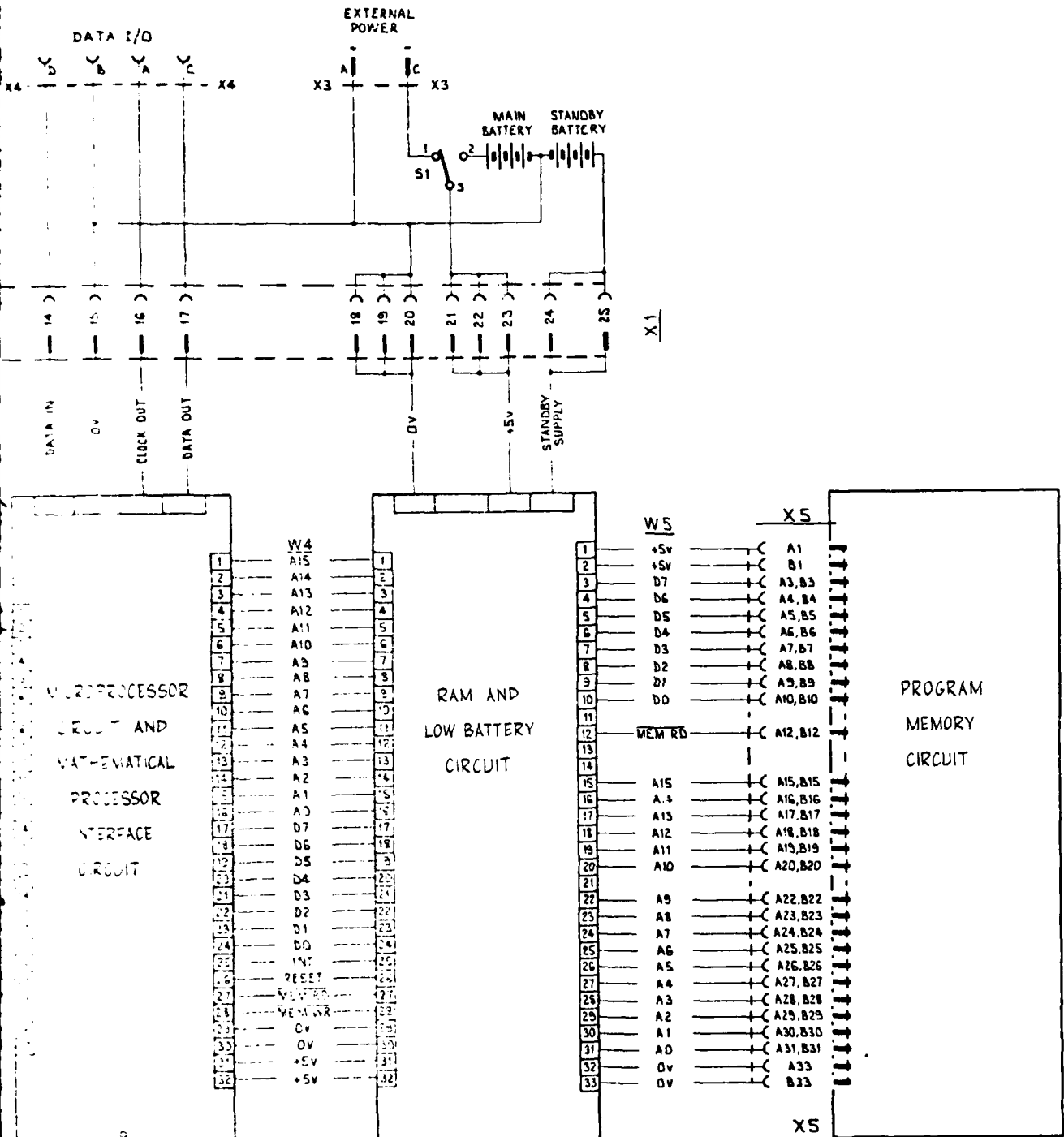

Figure 9. Wiring Diagram



9. Wiring Diagram

2

DISTRIBUTION

Copy No.

EXTERNAL

In United Kingdom

Defence Science Representative, London No copy

British Lending Library Division 1

In United States of America

Counsellor, Defence Science, Washington No copy

National Technical Information Services 2

Engineering Societies Library, New York NY 10017 3

In Australia

Chief Defence Scientist 4

Deputy Chief Defence Scientist 5

Superintendent, Science and Technology Programmes 6

Director, Joint Intelligence Organisation (DDSTI) 7

Document Exchange Centre

Defence Information Services Branch (for microfilming) 8

Document Exchange Centre

Defence Information Services Branch for:

UK Ministry of Defence 9

US Ministry of Defence 10 - 21

Canada Ministry of Defence 22

NZ Ministry of Defence 23

Australian National Library 24

Director, Industry Development, Regional Office, Adelaide 25

Defence Library, Campbell Park 26

Library, Aeronautical Research Laboratories 27

Library, Materials Research Laboratories 28

Army Scientific Adviser 29

School of Artillery

(Attention: Commanding Officer/Chief Instructor 30

Infantry Centre	
(Attention: Commanding Officer/Chief Instructor)	31
Armoured Centre	
(Attention: Commanding Officer/Chief Instructor)	32
Staff Officer (Science) HQ 1 Division	33
Staff Officer (Science) HQ FF Command	34
Staff Officer (Science) Training Command	35
Directorate, Quality Assurance (Melbourne)	
(Attention: Superintendent, Proof Establishment)	36
Director General, Army Development (NSO), Russell Offices for ABCA Standardisation Officers	
UK ABCA representative, Canberra	37
US ABCA representative, Canberra	38
Canada ABCA representative, Canberra	39
NZ ABCA representative, Canberra	40
Director of Artillery - Army	41
Director of Infantry - Army	42
Director of Armour - Army	43
Director of Operational Requirements - Army	44
Director of Armaments and Electronic Materiel - Army	45
Engineering Development Establishment - Melbourne	46
WITHIN DRCS	
Chief Superintendent, Weapons Systems Research Laboratory	47
Chief Superintendent, Advanced Engineering Laboratory	48
Chief Superintendent, Electronic Research Laboratory	49
Superintendent, Aeroballistics Division	50
Head of Composite, Ballistics	51
Senior Principal Research Scientist, Electronic Warfare	52
Principal Officer, Aerodynamics Research Group	53
Principal Officer, Ballistic Studies Group	54

Principal Officer, Field Experiments Group	55
S.G. Johnson, Ballistic Studies Group	56
F.G.P. Phillips, Ballistic Studies Group	57
J.F. Teague, Ballistic Studies Group	58
D. Bucco, Ballistic Studies Group	59
A.D. Hind, Field Experiments Group	60
R.L. Thornton, Field Experiments Group	61
A.I. Ware, Aeroballistics Engineering Section	62
Author	63
DRCS Library	64 - 65
AD Library	66 - 67
Spares	68 - 80

DOCUMENT CONTROL DATA SHEET

Security classification of this page

UNCLASSIFIED

<p>1 DOCUMENT NUMBERS</p> <p>AR Number: AR-002-635</p> <hr/> <p>Series Number: WSRL-0233-TR</p> <hr/> <p>Other Numbers:</p>	<p>2 SECURITY CLASSIFICATION</p> <p>a. Complete Document: Unclassified</p> <hr/> <p>b. Title in Isolation: Unclassified</p> <hr/> <p>c. Summary in Isolation: Unclassified</p>
--	--

3 TITLE

THE DESIGN OF A PORTABLE ALL ARMS CALCULATOR (PAAC)

<p>4 PERSONAL AUTHOR(S):</p> <p>C.J.P. Bensted</p>	<p>5 DOCUMENT DATE:</p> <p align="center">October 1981</p>
	<p>6</p> <p>6.1 TOTAL NUMBER OF PAGES: 17</p> <hr/> <p>6.2 NUMBER OF REFERENCES: 4</p>

<p>7</p> <p>7.1 CORPORATE AUTHOR(S):</p> <p>Weapons Systems Research Laboratory</p> <hr/> <p>7.2 DOCUMENT SERIES AND NUMBER</p> <p>Weapons Systems Research Laboratory 0233-TR</p>	<p>8 REFERENCE NUMBERS</p> <p>a. Task: DST 91/029</p> <hr/> <p>b. Sponsoring Agency:</p>
	<p>9 COST CODE:</p> <p align="center">318886</p>

<p>10 IMPRINT (Publishing organisation)</p> <p align="center">Defence Research Centre Salisbury</p>	<p>11 COMPUTER PROGRAM(S) (Title(s) and language(s))</p>
---	---

12 RELEASE LIMITATIONS (of the document):

Approved for Public Release

Security classification of this page:

UNCLASSIFIED

Security classification of this page:

UNCLASSIFIED

13 ANNOUNCEMENT LIMITATIONS (of the information on these pages):

No limitation

14 DESCRIPTORS:

a. EJC Thesaurus
Terms

Portable equipment
Fire control computers
Mortars (weapons)
Microprocessors
Armored vehicles
Artillery

b. Non-Thesaurus
Terms

15 COSATI CODES:

09020
19050

16 SUMMARY OR ABSTRACT:
(if this is security classified, the announcement of this report will be similarly classified)

A microprocessor based calculator is described which has been designed to provide assistance in determining aiming coordinates for Mortar fire control. However by changing the keyboard overlay and the software the calculator can be used for a variety of applications including Artillery and Armour fire control.

Security classification of this page:

UNCLASSIFIED

LATE
LME