

AD-A114 828

ELECTRONIC SYSTEMS PRODUCTS INC TITUSVILLE FL F/G 5/9
COLOR TELEVISION PROJECTION SYSTEM USING THREE CATHODE RAY TURE--ETC(U)
MAR 82 K W LINDENBERG F33615-78-C-0033

UNCLASSIFIED

AFHRL-TP-82-5

NL

[]

[]

[]

[]

[]

[]

[]

[]

[]

[]

[]

[]

[]

[]

[]

[]

[]

[]

[]

[]

[]

[]

[]

[]

[]

[]

[]

[]

[]

[]

[]

[]

[]

[]

[]

[]

[]

[]

[]

[]

[]

[]

[]

[]

[]

[]

[]

[]

[]

[]

[]

[]

[]

[]

[]

[]

END
DATE
FILMED
6 82
DTIC

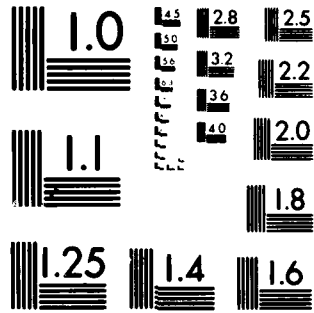

MICROCOPY RESOLUTION TEST CHART
NATIONAL BUREAU OF STANDARDS 1963-A

AFHRL-TP-82-5

(12)

AIR FORCE



**COLOR TELEVISION PROJECTION SYSTEM
USING THREE CATHODE RAY TUBES**

By

Klaus W. Lindenberg

**Electronic Systems Products, Inc.
One Tico Road
Titusville, Florida 32780**

**OPERATIONS TRAINING DIVISION
Williams Air Force Base, Arizona 85224**

AD A114828

HUMAN RESOURCES

DTIC ELECTRONIC
S MAY 26 1982 **A**

March 1982

Final Report

Approved for public release: distribution unlimited.

LABORATORY

DTIC FILE COPY

**AIR FORCE SYSTEMS COMMAND
BROOKS AIR FORCE BASE, TEXAS 78235**

82 05 26 087

NOTICE

When Government drawings, specifications, or other data are used for any purpose other than in connection with a definitely Government-related procurement, the United States Government incurs no responsibility or any obligation whatsoever. The fact that the Government may have formulated or in any way supplied the said drawings, specifications, or other data, is not to be regarded by implication, or otherwise in any manner construed, as licensing the holder, or any other person or corporation; or as conveying any rights or permission to manufacture, use, or sell any patented invention that may in any way be related thereto.

The Public Affairs Office has reviewed this paper, and it is releasable to the National Technical Information Service, where it will be available to the general public, including foreign nationals.

This paper has been reviewed and is approved for publication.

WELDON M. DUBE
Contract Monitor

MILTON E. WOOD, Technical Director
Operations Training Division

RICHARD G. CRONQUIST, Colonel, USAF
Chief, Operations Training Division

Unclassified

SECURITY CLASSIFICATION OF THIS PAGE (When Data Entered)

REPORT DOCUMENTATION PAGE		READ INSTRUCTIONS BEFORE COMPLETING FORM
1. REPORT NUMBER AFHRL-TP-82-5	2. GOVT ACCESSION NO.	3. RECIPIENT'S CATALOG NUMBER
4. TITLE (and Subtitle) COLOR TELEVISION PROJECTION SYSTEM USING THREE CATHODE RAY TUBES		5. TYPE OF REPORT & PERIOD COVERED Final
		6. PERFORMING ORG. REPORT NUMBER
7. AUTHOR(s) Klaus W. Lindenberg		8. CONTRACT OR GRANT NUMBER(s) F33615-78-C-0033
9. PERFORMING ORGANIZATION NAME AND ADDRESS Electronic Systems Products, Inc. One Tico Road Titusville, Florida 32780		10. PROGRAM ELEMENT, PROJECT, TASK AREA & WORK UNIT NUMBERS 63227F 19580110
11. CONTROLLING OFFICE NAME AND ADDRESS HQ Air Force Human Resources Laboratory (AFSC) Brooks Air Force Base, Texas 78235		12. REPORT DATE March 1982
		13. NUMBER OF PAGES 12
14. MONITORING AGENCY NAME & ADDRESS (if different from Controlling Office) Operations Training Division Air Force Human Resources Laboratory Williams Air Force Base, Arizona 85224		15. SECURITY CLASS. (of this report) Unclassified
		15a. DECLASSIFICATION/DOWNGRADING SCHEDULE
16. DISTRIBUTION STATEMENT (of this Report) Approved for public release: distribution unlimited.		
17. DISTRIBUTION STATEMENT (of the abstract entered in Block 20, if different from Report)		
18. SUPPLEMENTARY NOTES		
19. KEY WORDS (Continue on reverse side if necessary and identify by block number) cathode ray tube (CRT) visual simulation optics		
20. ABSTRACT (Continue on reverse side if necessary and identify by block number) The purpose of this project is to provide for the design, development, and fabrication of advanced simulation systems in order to test and demonstrate their performance capabilities. These tests and demonstrations will be used to establish the technical feasibility, as well as the performance characteristics, of systems which might be used in operational simulators in future years. The work described in this report applies to the area of visual simulation.		

DD FORM 1473

1 JAN 73

EDITION OF 1 NOV 65 IS OBSOLETE

Unclassified

SECURITY CLASSIFICATION OF THIS PAGE (When Data Entered)

**COLOR TELEVISION PROJECTION SYSTEM
USING THREE CATHODE RAY TUBES**

By

Klaus W. Lindenberg

**Electronic Systems Products, Inc.
One Tico Road
Titusville, Florida 32780**

Reviewed and Submitted for Publication By

**PETER A. COOK, Lt Col, USAF
Deputy Chief, Engineering Branch
Operations Training Division
Williams Air Force Base, Arizona 85224**

This publication is primarily a working paper.
It is published solely to document work performed.



Accession For	
NTIS GRA&I	<input checked="" type="checkbox"/>
DTIC TAB	<input type="checkbox"/>
Unannounced	<input type="checkbox"/>
Justification	
By	
Distribution/	
Availability Codes	
Avail and/or	
Dist. Statement	
A	

TABLE OF CONTENTS

	<u>Page</u>
1.0 Introduction	3
2.0 Scope	3
3.0 Background	3
4.0 Technical Results	4
4.1 Overall System Description	4
4.2 CRT Cooling	4
4.3 Optics	5
4.4 Video System	6
4.5 Deflection Systems	7
4.6 High Voltage Power Supplies	7
4.7 Auxiliary Equipment	7
5.0 Test Results	8
6.0 Conclusions	8

1.0 INTRODUCTION

The Air Force Human Resources Laboratory (AFHRL) has established Project 1958 for the development of advanced visual, motion, and sensor simulation systems. The purpose of this project is to provide for the design, development and fabrication of advanced simulation systems in order to test and demonstrate their performance capabilities. These tests and demonstrations will be used to establish the technical feasibility as well as performance characteristics of systems which might be used in operational simulators in future years. The work described in this report applies to the area of visual simulation within Project 1958.

More specifically, the work described herein deals with the design and development of a three-CRT color television projection system. Electronic Systems Products earlier made a number of significant advances in the development of an optical matrixing system for three cathode ray tubes. These technical breakthroughs were at that time believed to be capable of leading towards a quite inexpensive image source for flight simulator visual systems, without sacrificing the quality of the displayed imagery. The work subsequently performed under the auspices of this contract to design and develop a breadboard projector and, ultimately, a fully functional prototype projector has confirmed that the potential of high performance and low cost can, in fact, be achieved.

2.0 SCOPE

The work performed under this contract included the design, development, testing and installation of an improved CRT color television projector for displaying real world or computer generated imagery for the trainee/pilot in a flight simulator. Initially a brief and fundamental study of electron optics was undertaken in order to provide higher brightness and higher resolution while shortening the CRT glass envelopes so as to provide a reasonably compact package. The results of this initial study made it possible to produce a 1000 line resolution prototype projector capable of displaying the computer generated imagery produced by the facilities at Williams Air Force Base, Arizona.

3.0 BACKGROUND

A large number of different television projection techniques have been used. These techniques can be divided into several categories, specifically: light valves, scophony, lasers, liquid crystal modulation, and cathode ray tubes. Of these display techniques, the light valves

are capable of the highest light output, but suffer from mechanical and electrical complexity, are difficult to operate and maintain, and have comparatively short life times associated with critical components. Both scophony and laser techniques utilize mechanical beam scanning techniques which severely limit their operating spectrum. Liquid crystal techniques are still largely experimental, suffering from slow refresh rates and lags.

High energy cathode ray tubes have been improved in their electron optics, phosphors and glass envelopes. Faceplate brightnesses in the range of 15,000 to 25,000 foot lamberts are readily achievable. Electron beam spot sizes of .002 inch to .004 inch can be achieved with special electron guns and focusing fields.

In the past, and in most of the consumer television projection systems on the market today, the major limitation in average power dissipation has been the temperature rise at the faceplate of the CRTs. Excessive faceplate heating invariably leads to cracking of the glass tube envelope itself.

A variety of faceplate cooling techniques have been employed, as has the utilization of extremely expensive faceplate materials such as sapphire, having low temperature coefficients.

Despite this latter difficulty, projection CRT systems still appear to have the highest performance-to-cost ratios of any of the currently available technologies.

4.0 TECHNICAL RESULTS

4.1 OVERALL SYSTEM DESCRIPTION

The CRT projector consists of three cathode ray tubes capable of high resolution and high brightness, each with a single color phosphor (red, blue and green) and arranged in a "T" formation mounted 90° relative to one another. A crossed dichroic mirror system is located at the common axis. One of the mirrors reflects blue while passing red and green, and the other mirror reflects red while passing blue and green. A single refractive lens is focused onto the three images to project a single combined color image. Figure 1 depicts the mechanical arrangement.

4.2 CRT COOLING

As was mentioned earlier, the proper cooling of the CRT faceplates is critical if a high average power dissipation is to be achieved. Since image brightness is directly

related to power dissipation, it is clearly desirable to be able to raise average power delivered to the phosphors as much as possible.

Air cooling of the CRT faceplates poses several problems. A stream of air blown across them causes rapid dust precipitation due to the high voltage electrostatic field present. Furthermore, a tangential flow of air across the hot faceplates causes non-uniform cooling which in turn aggravates the possibility of the tubes' cracking. Also, the close proximity of the tubes to the dichroic mirror system makes it mechanically difficult to implement an effective air cooling system.

Because of these difficulties, ESP utilized a liquid cooling system for each of the CRTs. The bell of each CRT was first bonded to a lead filled epoxy shroud which extends slightly forward of the faceplate and aft just short of the neck of the tube in order to allow subsequent mounting of the deflection yokes. The forward flange of the epoxy shroud was then bonded to an aluminum mounting plate with a window machined in it. The forward side of this mounting plate, that is, the side facing the dichroic mirror system, was fitted with an X-ray absorbing glass plate. The intervening space between the CRT faceplate and the lead filled glass window was then filled with a cooling fluid.

Liquid cooling had been used before by ESP and others, and tests have revealed that better phosphor gamma characteristics and longer CRT life results. In order to be effective, however, the liquid coolant must have a number of special properties. These include a high refractive index, low dispersion, chemical inertness, temperature stability, clarity, medium viscosity, high dielectric strength and x-ray stability.

The testing of this cooling system revealed that a three inch by four inch (3" x 4") raster could be projected at a power level of 150 watts for eight hours with final temperature stabilizing at 120 degrees Fahrenheit. The selected coolant's viscosity eliminated any optical striations produced by temperature gradients.

4.3 OPTICS

As can be seen from Figure 1, the mechanical arrangement of the Three-CRT/Lens Combination makes for a fairly simple and straightforward optical system. It had been hoped originally that the dichroic mirror mounting frame could have been totally sealed and filled with liquid. This would have had the advantage of presenting the projection lens with an apparent image much closer to the

first lens element than possible by using an air filled chamber. However, it was found that the practical difficulties of constructing such a chamber far outweighed its advantages. The combination of precise optical alignment of the CRTs, X-ray shielding, hermetic sandwiching of dichroic mirrors, not to speak of the additional mass of the necessary fluid volume, represented a series of difficulties whose solution was not warranted at the prototype level. The only performance factor noticeably affected by not filling the dichroic chamber with fluid was that the optical train did not have quite the speed that it might have had. However, in view of the power levels and brightness inherently produced by the three-CRT combination, this slight loss of optical speed is not apparent to the user.

In the final design, the removal of the fluid filled chamber is compensated by placing the first element of the projection lens on the peripheries of the dichroic chamber immediately in front of each of the CRTs. Thus, there are in fact, three first elements of the single lens system. All the advantages of a single exit pupil lens system are, of course, retained.

The primary advantage of this system is that a monochromatic lens may be used to project the image. This results from the fact that the three primary colors are generated separately and may be focused individually to compensate for axial color shift, and the individual raster images may be sized to correct for lateral color shift. The simplicity of a monochromatic lens allows for faster speeds than would otherwise be possible.

The single exit pupil system is such that the three images can be symmetrically placed, thereby simplifying registration. A high gain screen may be used to great advantages without color shading. X-rays are readily absorbed from the tube faceplates, making shielding more convenient than in conventional projectors.

Lens tilt and keystoneing are also easily accomplished for off axis projection, and different optical throw distances may be conveniently employed.

4.4 VIDEO SYSTEM

The video system was built up from commercially available modules having amplifier bandwidths of 30 MHz for a 1,200 line bandpass. The output stages of this circuitry were slightly modified so as to provide for the required voltage swings and bandwidth at the CRT cathodes. These modifications are identified specifically in the systems

maintenance manual, and on the appropriate schematic diagrams. Video peaking and enhancing are incorporated in the circuitry in order to provide for effective improvements of the modulation transfer function in the horizontal scan plane.

Also incorporated in the video processing system is a test pattern generator which allows for the generation of cross-hatch and cross-hair patterns to facilitate system registration and convergence.

4.5 DEFLECTION SYSTEMS

The horizontal and vertical deflection system is built from commercially available modules. Deflection circuitry is adjustable to accommodate vertical sweep rates from 50 to 60 Hz and horizontal scan rates are switch selectable in three overlapping ranges running from 525 to 1,203 lines.

The synchronization circuitry incorporates phase sensing for maximum stability. Function generators develop signals that magnetically and electronically mix with the master deflection waveforms so as to shape and register accurately the red, green and blue images.

Current feedback from the yokes senses drift and waveform alterations.

4.6 HIGH VOLTAGE POWER SUPPLIES

The high voltage power supply utilized in the three-CRT projector was built from two of ESP's commercial supplies operating in a master/slave configuration.

The high voltage power supply operates at 45 KV and has a peak current capability of approximately 24 milliamps. Both overvoltage and overcurrent protection are built in, and in case of catastrophic regulator failure the supply shuts down automatically. The high voltage cables leading to each of the CRTs are encapsulated into the X-ray shield around the tube. Deep, self-bleeding plug-in sockets are provided where the individual high voltage lines from the CRTs meet the power supply output cable.

X-ray shielding of the entire projector assembly is such as to be well within Occupational Safety & Health Act (OSHA) standards.

4.7 AUXILIARY EQUIPMENT

Because high resolution color inputs might not be

always readily available, a National Television Standard Code (NTSC) color demodulator was constructed together with the necessary drive circuitry. A television tuner and the associated circuitry were also incorporated, thereby allowing "off the air" or studio type cameras or tapes to be fed into the projector inputs. This circuitry was housed in a separate cabinet.

5.0 TEST RESULTS

The projector was run through a number of tests during the acceptance proceedings held at ESP's facilities and continues to be evaluated further at Williams Air Force Base where it was subsequently delivered. During the inplant acceptance tests a high resolution camera was utilized to serve as the input source. The projector's image resolution capabilities were established as being 800 line resolution utilizing a standard television resolution test chart. Contrast ratio was found to be in excess of 30 to 1.

The bandwidth of the electronics was found to be approximately 20 MHz, the limiting factors being the gain/bandwidth products of the final stage semiconductors being used.

Geometric distortion of the four corners relative to the center of the image was found to be within three percent.

X-radiation emission of the projector was measured with a Victoreen survey meter and was found to be less than .2 mR/hr, well within the OSHA standards. All x-ray measurements were done within one centimeter of the surface of the projector.

Peak light output of the projector was measured using a Toconix 8 degree cone light meter. Peak level was measured utilizing a 20 per cent area white patch and was found to be approximately 350 lumens.

6.0 CONCLUSIONS

The performance of the projection system, once it had been installed and calibrated at Williams Air Force Base, was deemed to be excellent and indeed surprised both the contractor and AFHRL personnel.

Two major areas for further development and improvement can be identified. The first of these is the optical train. The multi-element plastic prototype lens could

easily be improved in terms of its field flatness and astigmatic properties. Since the lens was designed early in the project before a number of alterations had been made to the basic design, it ultimately did not quite match the final prototype projector design. At the time of its development, the lens design and implementation required many months before evaluation could take place. Presently ESP has an in house capability for lens design, manufacture and evaluation. The cycle time from design through field trial has been reduced to a matter of days and weeks rather than months so that further improvement of the lens system could be a rapid and relatively simple undertaking.

The second major area of improvement for the projection system is in the realm of the final video amplifier stages. As was mentioned earlier, capabilities of present state of the art semiconductors do not quite match the gain/bandwidth products required for this type of device. Since delivery of the projector, ESP has undertaken further research in the design of wide bandwidth high power video amplifiers utilizing ceramic tubes and, once again, results are significantly encouraging to be able to say that the bandwidth of the projector could be extended to 30 MHz and beyond without major effort.

The combination of these two areas of endeavor should yield a system of superior performance at a cost unmatched by other display devices.

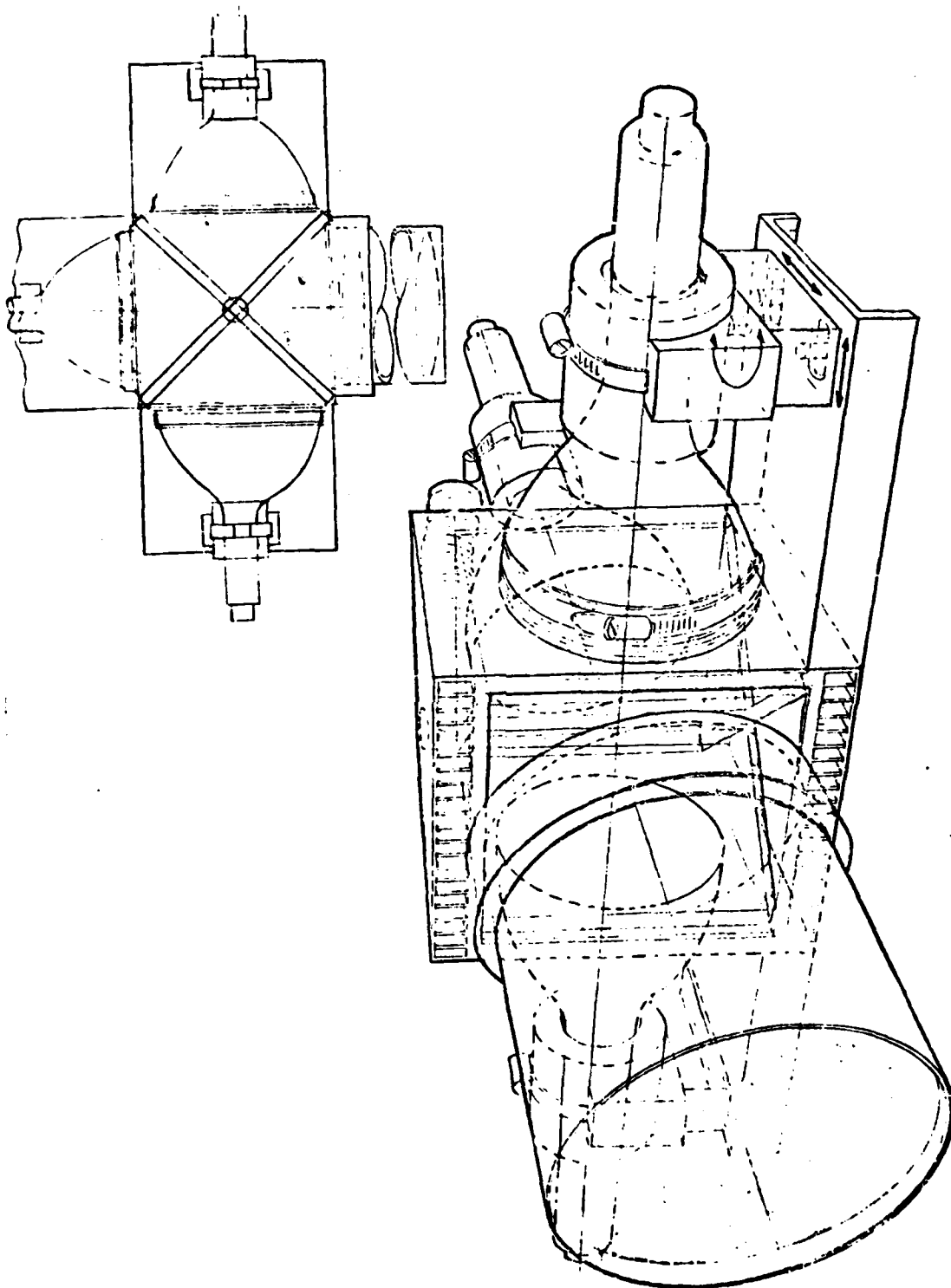

Figure 1. Color television projection system using three cathode ray tubes.

DATE
FILME
— 88